

Proceedings of the

Workshop on Gate Valve Pressure Locking and Thermal Binding

Held at
Marriott Hotel
New Orleans, LA
February 4, 1994

Prepared by
Earl J. Brown

Sponsored by
Office for Analysis and Evaluation of Operational Data
Office of Nuclear Reactor Regulation
U.S. Nuclear Regulatory Commission
Washington, DC 20555-0001

Prepared by
U.S. Nuclear Regulatory Commission



AVAILABILITY NOTICE

Availability of Reference Materials Cited in NRC Publications

Most documents cited in NRC publications will be available from one of the following sources:

1. The NRC Public Document Room, 2120 L Street, NW., Lower Level, Washington, DC 20555-0001
2. The Superintendent of Documents, U.S. Government Printing Office, P. O. Box 37082, Washington, DC 20402-9328
3. The National Technical Information Service, Springfield, VA 22161-0002

Although the listing that follows represents the majority of documents cited in NRC publications, it is not intended to be exhaustive.

Referenced documents available for inspection and copying for a fee from the NRC Public Document Room include NRC correspondence and internal NRC memoranda; NRC bulletins, circulars, information notices, inspection and investigation notices; licensee event reports; vendor reports and correspondence; Commission papers; and applicant and licensee documents and correspondence.

The following documents in the NUREG series are available for purchase from the Government Printing Office: formal NRC staff and contractor reports, NRC-sponsored conference proceedings, international agreement reports, grantee reports, and NRC booklets and brochures. Also available are regulatory guides, NRC regulations in the *Code of Federal Regulations*, and *Nuclear Regulatory Commission Issuances*.

Documents available from the National Technical Information Service include NUREG-series reports and technical reports prepared by other Federal agencies and reports prepared by the Atomic Energy Commission, forerunner agency to the Nuclear Regulatory Commission.

Documents available from public and special technical libraries include all open literature items, such as books, journal articles, and transactions. *Federal Register* notices, Federal and State legislation, and congressional reports can usually be obtained from these libraries.

Documents such as theses, dissertations, foreign reports and translations, and non-NRC conference proceedings are available for purchase from the organization sponsoring the publication cited.

Single copies of NRC draft reports are available free, to the extent of supply, upon written request to the Office of Administration, Distribution and Mail Services Section, U.S. Nuclear Regulatory Commission, Washington, DC 20555-0001.

Copies of industry codes and standards used in a substantive manner in the NRC regulatory process are maintained at the NRC Library, Two White Flint North, 11545 Rockville Pike, Rockville, MD 20852-2738, for use by the public. Codes and standards are usually copyrighted and may be purchased from the originating organization or, if they are American National Standards, from the American National Standards Institute, 1430 Broadway, New York, NY 10018-3308.

DISCLAIMER NOTICE

Where the papers in these proceedings have been authored by contractors of the United States Government, neither the United States Government nor any agency thereof, nor any of their employees, makes any warranty, expressed or implied, or assumes any legal liability or responsibility for any third party's use, or the results of such use, of any information, apparatus, product, or process disclosed in these proceedings, or represents that its use by such third party would not infringe privately owned rights. The views expressed in these proceedings are not necessarily those of the U.S. Nuclear Regulatory Commission.

DISCLAIMER

This report was prepared as an account of work sponsored by an agency of the United States Government. Neither the United States Government nor any agency thereof, nor any of their employees, make any warranty, express or implied, or assumes any legal liability or responsibility for the accuracy, completeness, or usefulness of any information, apparatus, product, or process disclosed, or represents that its use would not infringe privately owned rights. Reference herein to any specific commercial product, process, or service by trade name, trademark, manufacturer, or otherwise does not necessarily constitute or imply its endorsement, recommendation, or favoring by the United States Government or any agency thereof. The views and opinions of authors expressed herein do not necessarily state or reflect those of the United States Government or any agency thereof.

DISCLAIMER

Portions of this document may be illegible in electronic image products. Images are produced from the best available original document.

Proceedings of the

Workshop on Gate Valve Pressure Locking and Thermal Binding

Held at
Marriott Hotel
New Orleans, LA
February 4, 1994

Manuscript Completed: July 1995
Date Published: July 1995

Prepared by
Earl J. Brown

Sponsored by
Office for Analysis and Evaluation of Operational Data
Office of Nuclear Reactor Regulation
U.S. Nuclear Regulatory Commission
Washington, DC 20555-0001

Prepared by
U.S. Nuclear Regulatory Commission
Washington, DC 20555-001



ABSTRACT

The purpose of the Workshop on Gate Valve Pressure Locking and Thermal Binding was to discuss pressure locking and thermal binding issues that could lead to inoperable gate valves in both boiling water and pressurized water reactors. The goal was to foster exchange of information to develop the technical bases to understand the phenomena, identify the components that are susceptible, discuss actual events, discuss the safety significance, and illustrate known corrective actions that can prevent or limit the occurrence of pressure locking or thermal binding. The presentations were structured to cover U.S. Nuclear Regulatory Commission staff evaluation of operating experience and planned regulatory activity; industry discussions of specific events, including foreign experience, and efforts to determine causes and alleviate the affects; and valve vendor experience and recommended corrective action. The discussions indicated that identifying valves susceptible to pressure locking and thermal binding was a complex process involving knowledge of components, systems, and plant operations. The corrective action options are varied and straightforward.

CONTENTS

ABSTRACT	iii
FOREWORD	vii
INTRODUCTORY LETTER	1
Public Workshop Meeting Agenda	9
List of Meeting Participants	13
Questions Received From Public in Response to Federal Register Notice	25
Pressure Locking and Thermal Binding Issues — U.S. Nuclear Regulatory Commission Earl J. Brown and Chuck Hsu, Office for Analysis and Evaluation of Operational Data	33
Industry Experience and Efforts	57
Licensee Experience	
Dana Smith, Entergy Operations Inc.	59
International Experience	
Nabil Schauki, Siemens Power Corporation	75
Licensee Experience	
Mark Dowd, LaSalle County Station	93
Licensee Experience	
Dick Kadlec, American Electric Power Service Corporation	181
Licensee Experience	
William R. Rowlett, Jr. P.E., Arkansas Nuclear One	
James M. Warren, P.E., Gilbert/Commonwealth	191
Vendor Actions	
Ike Ezekoye, Westinghouse Electric Corporation	235
Vendor Actions	
Drew W. Wright, Anchor/Darling Valve Co.	261
Vendor Actions	
John M. Farrell, Velan Valve Corporation	275
Draft Generic Communication — U.S. Nuclear Regulatory Commission Thomas G. Scarbrough, Office of Nuclear Reactor Regulation	295

FOREWORD

The U.S. Nuclear Regulatory Commission staff and the nuclear industry have been aware of gate valve disc binding problems for many years. The industry has issued several event reports describing safety-related gate valve failures to operate due to pressure locking or thermal binding of the valve discs. Several generic industry communications have given guidance for both identifying susceptible valves and performing appropriate preventive and corrective measures. Despite industry awareness of the problems, pressure locking and thermal binding events continue to occur. The purpose of the Workshop was to have licensees, manufacturers, consultants, and regulators exchange technical information about the phenomena.

In March 1993, the NRC issued NUREG-1275, Volume 9, "Pressure Locking and Thermal Binding of Gate Valves." This NUREG gives the history of pressure locking and thermal binding events, describes the phenomena, discusses the consequences of locking or binding on valve functionality, summarizes preventive measures, and assesses the safety significance of the phenomena. Pressure locking or thermal binding can cause a power-operated valve to fail to open, resulting in an inability of the associated safety train or system to perform its safety function. Pressure locking and thermal binding represent potential common-cause failure mechanisms that can render redundant trains of certain safety-related systems or multiple safety systems incapable of performing their safety function. Such failures may not be self-revealing through existing surveillance tests or normal operating cycles.

After issuing the NUREG, the NRC staff discussed pressure locking and thermal binding with several licensees to: (1) gather information on the technical issues related to generic and plant-specific valve and system characteristics, and (2) determine the implementation status of prior industry guidance for identification of susceptible valves and application of preventive and corrective measures. NRC surveys indicated that some licensees had performed multiple reviews of pressure locking and thermal binding. However, the staff found only limited instances of valves being modified to alleviate the effects of pressure locking or thermal binding.

Further, these staff investigations of gate valve pressure locking and thermal binding events indicated that identifying those valves susceptible to the phenomena is a complex process involving knowledge of components, systems, and plant operations. Component aspects include understanding operation of the valve, knowledge of valve design that can affect thrust requirements to lift the discs off the seats, and knowledge of the process used to determine operator thrust requirements. System considerations involve knowledge of system conditions during all modes of plant operation, pump and valve alignments and operations, and knowledge of pump and valve start signals during all modes of plant operation including transients, accidents, and recovery actions hours after an accident. Operations aspects relate to knowledge of plant operation from startup to shutdown throughout a full fuel cycle to include systems or trains used and when, system temperature and pressure conditions in various modes, interface conditions (especially temperature and pressure) between systems or trains (or modes of a system), and valve proximity to fluid temperature change (heatup or cooldown) or valve exposure to pressure difference.

An observation from NRC staff discussions with licensees was that those most successful in identifying valves susceptible to pressure locking and thermal binding utilized an interdisciplinary team composed of valve experts, systems engineers, and plant operations staff. This approach would also enhance appreciation of plant operation effects on valve susceptibility to pressure locking and thermal binding. The Workshop was organized to address these diverse aspects through presentations of actual events, event evaluations, and implemented corrective actions.

INTRODUCTORY LETTER



UNITED STATES
NUCLEAR REGULATORY COMMISSION

WASHINGTON, D.C. 20555-0001

February 10, 1994

MEMORANDUM FOR: Jack E. Rosenthal, Chief
Reactor Operations Analysis Branch
Division of Safety Programs
Office for Analysis and Evaluation of Operational Data

John N. Hannon, Director
Project Directorate III-3
Division of Reactor Projects III/IV/V
Office of Nuclear Reactor Regulation

FROM: Earl J. Brown, Chief
Engineering Section, Reactor Operations Analysis Branch
Division of Safety Programs
Office for Analysis and Evaluation of Operational Data

Allen G. Hansen, Project Manager
Project Directorate III-3
Division of Reactor Project III/IV/V
Office of Nuclear Reactor Regulation

SUBJECT: SUMMARY OF PUBLIC WORKSHOP ON GATE VALVE PRESSURE LOCKING
AND THERMAL BINDING

On February 4, 1994, AEOD and NRR, together with Research and Regional staff, hosted a public workshop with representatives of the nuclear industry, including licensees, vendors and consultants. The purpose of the workshop was to discuss potential pressure locking and thermal binding of gate valves at nuclear power reactors. Enclosure 1 is the agenda and Enclosure 2 is a list of the workshop participants. Each presentation is summarized below, in the order shown on the agenda. AEOD is also preparing a detailed NUREG which will provide broader discussions of each of the issues raised at the meeting.

Enclosure 3 provides a copy of questions received by the staff in response to the Federal Register Notice [58FR62687], published on November 29, 1993, announcing the workshop. Only one member of the public responded, and the questions posed were addressed during the course of the workshop.

WELCOME AND INTRODUCTION (Jack Rosenthal, AEOD, and John Hannon, NRR)

The purpose and format of the workshop were discussed, together with the history of the issues to be addressed. Attendees were referred to NUREG-1275 (Volume 9) for more historical details and discussions of potential remedial actions to address pressure locking and thermal binding issues. The staff has published many information notices and other generic communications regarding pressure locking and thermal binding, and this workshop was designed to help industry focus on these issues. Concern was expressed that plant operations may not be getting adequate attention by those addressing pressure locking and thermal binding. Recent PRA analyses indicated that the conditional core

damage frequency could significantly increase due to common mode failures caused by pressure locking and/or thermal binding.

NRC STAFF SUMMARY OF PRESSURE LOCKING AND THERMAL BINDING ISSUES (Earl Brown and Chuck Hsu, AEOD, See Enclosure 4)

NUREG-1275 (Volume 9) was referenced regarding an historical perspective. The presenters stated that flexible wedge, double disc and parallel slide gate valves were most susceptible to pressure locking while solid wedge valves were most susceptible to thermal binding. For pressure locking to occur, there must be a source of water to fill the bonnet, and a mechanism to increase the bonnet pressure, such as heating the enclosed water or pressure from a connected system. Bonnets can become pressurized due to ambient temperature effects. Thermal binding (due to differential contraction of dissimilar metals in the valve body and disc) can be caused by temperature gradients.

For proper analysis, the precursors to pressure locking must be understood, particularly with regard to normal plant operations, inservice testing, and post-accident situations. With regard to operations, re-alignment of valves after tests can lead to problems. Normal valve alignments must be studied. The Vogtle pressure locking case was referenced as an example. Several improper assumptions such as lack of operational maintenance history, no leakage past inline check valves, and consideration of normal operations only can prevent the identification of susceptible valves. Because of the broad, complex nature of the contributing factors to pressure locking, a team approach utilizing people with expertise in component operation, system operation, and plant operations should be employed.

There are several stages to lockup. Partial lockup can cause damage to a valve that is not immediately obvious. For example, locked rotor current in 10 to 15 seconds can degrade the torque capability and possibly burn up the windings.

Possible scenarios for pressure locking in various systems were discussed for both BWR and PWR plants, and included sump suction, RHR, low pressure safety injection, and core spray valves, and PORV block valves. Flex wedge, split wedge, parallel slide and double disc gate valves have the potential for pressure locking.

The conclusion was that no generalizations regarding valve susceptibility to pressure locking and/or thermal binding can be made. Rather, all valves must be looked at individually as related to their environments during all modes of plant operations, including the full accident sequence.

LICENSE EXPERIENCE - ENTERGY/GRAND GULF (Dana Smith, Entergy Operations, Incorporated, see Enclosure 5)

Grand Gulf re-evaluated their flex wedge gate valves, and determined that a method to predict pressure locking problems was needed. They developed an analysis technique to predict total required stem thrust and initially utilized it as a justification for continued operation. One valve, a 14-inch Powell gate valve, has been laboratory tested as part of the validation process. Modifications have already been made on many valves, and other

problem valves are to be modified during the next outage. They have chosen external modifications because they preferred not to deal with problems associated with disassembly/re-assembly.

INTERNATIONAL EXPERIENCE - SIEMENS (N. Schauki, Siemens, see Enclosure 6)

Pressure locking of gate valves was discovered at fossil plants in Germany almost 30 years ago. Tests were conducted to determine the pressure increase versus the temperature in the bonnets. The tests began at 63 °F and showed that bonnet pressure increased rapidly after the temperature exceeded 70 °F. The bonnet pressure was 1000 psi when the temperature reached 100 °F. Techniques were developed to solve the problems, and included disc drilling and valve bonnet internal venting. Recently, relief valves have been used, and a new valve design, utilizing a disc holder, has been developed. The disc holder concept allows the disc to float, seating downstream of the high pressure side of the valve. If the downstream pressure increases, then the disc can float to the upstream seating surface. This provides a relief path from the bonnet to the high pressure side of the disc, regardless of the direction of the pressure gradient across the valve.

The presenter also mentioned a problem which can occur when two globe valves are installed in opposite orientations in a piping system, and both are closed. The fluid between the two valves can achieve very high pressure due to temperature increases, possibly challenging the pressure boundary.

LICENSEE EXPERIENCE - COMMONWEALTH EDISON/LASALLE (Mark Dowd, LaSalle Station, see Enclosure 7)

The presenter, who has many years experience in operations (up through the supervisor level, stated that regardless of the precautions, operator error is possible. Therefore, the operators should not be needlessly challenged.

An event at LaSalle regarding pressure locking of an RCIC valve was described in great detail. The valve was changed from a flex wedge to a double disc valve due to high pull out forces and leakage. In cycling the new valve, pressure locking occurred, and internal retaining pins on the valve sheared. A multi-discipline team (engineering, operations and maintenance) was formed to evaluate the problem, and developed a list of questions used to determine susceptibility to pressure locking. They reviewed 750 valves (of which 301 are included in the Generic Letter [GL] 89-10 program), and found 40 different categories of valves which were susceptible. This review took approximately three months. PRA was used for prioritization, and all ECCS valves were included in the high priority group. To date, one valve disc has been drilled, with modifications to other valves planned in upcoming outages.

Thermal binding was also discussed. A temperature gradient was established across a valve because of plant conditions, and the valve subsequently failed to open due to thermal binding. Also, ambient temperature effects can cause pressure locking, as demonstrated by the event at LaSalle. The presenter emphasized that both pressure locking and thermal binding are real and need to be properly analyzed using a team approach. As a result of their research, they presented information that illustrated a valve initially at 84 °F

subjected to an external 64 °F temperature rise (148 °F air temperature) resulted in a bonnet pressure of 2000 psi within 15 to 20 minutes depending upon the heat transfer coefficient. They also described an event in which the presence of condensate in a steam system valve caused pressure locking.

In response to a question from the audience, organic intrusion into systems due to valve modifications was discussed. The presenter was emphatic in stating that these concerns are real and must be analyzed, but that they are much less important than pressure locking.

LICENSEE EXPERIENCE - AMERICAN ELECTRIC POWER/D.C. COOK (Dick Kadlec, D.C. Cook, see Enclosure 8)

The presenter stated that pressure locking and thermal binding were considered as part of the original plant design. When thermal binding was suspected, parallel slide valves were utilized. Some containment sump recirculation valves had equalizing lines installed to protect against pressure locking, but were later removed following a study conducted in response to an INPO generic communication.

After discussing valve problem history at Cook, the presenter mentioned that equalizing lines, instead of disc drilling, had been employed. Double disc valves were modified first, then flex wedge valves. They chose not to drill the discs because they did not want the valves to become unidirectional. The licensee conducted a study of valves, which operations reviewed. Out of 200 valves, 80 were considered for modification.

LICENSEE EXPERIENCE - ENTERGY/ANO (Bill Rowlett, ANO and Jim Warren, Gilbert Commonwealth, see Enclosure 9)

ANO has a proactive program to address all possible valve locking problems. The presenters stated that they believed it was more cost effective to modify valves than to perform a detailed analysis to justify no modifications. The licensee has identified 181 gate valves under the GL 89-10 program for the two units at the site. Valve data were analyzed to determine which valves needed particular attention regarding potential locking. A total of 74 valves were identified that required further review, and were placed into four categories: thermal binding, pressure locking, proximity effect locking, and environmental effect locking. Of these valves, 28 have the potential for pressure locking and 18 have the potential for thermal binding.

The potential susceptibility of containment sump recirculation valves to pressure locking was discussed. One issue of concern is whether there is a mechanism to fill the bonnet with water, such as during plant startup. Both the B&W and CE units at ANO have intervening valves that are closed during plant startup. This appears to be an option to reduce or alleviate subsequent pressure locking of these valves.

VENDOR ACTIONS - WESTINGHOUSE (Ike Ezekoye, Westinghouse Electric Corporation, see Enclosure 10)

Westinghouse has conducted laboratory tests on valves, and has proposed corrective actions for field use. They expect the licensees to provide them

with the valve conditions which must be accounted for in the design. The advantages and disadvantages of four corrective measures were discussed. When a valve is modified by drilling a hole in the disc, the hole size should be limited (about 1/8 inch or less). The use of manual isolation valves for relief lines is difficult to implement on small valves. When relief valves are used which vent back into the system, sizing and lift point are critical issues. When venting to other areas, these concerns are not as critical. When providing a vent by installing an internal hole in the valve body, the hole may be more susceptible to blockage than a hole in the disc, which can be flushed by system flow.

VENDOR ACTIONS - ANCHOR DARLING (Drew Wright, Anchor Darling, see Enclosure 11)

The presenter discussed some of Anchor Darling's findings and potential solutions to pressure locking and thermal binding problems. They indicated there may be cases where valve bodies and discs have different coefficients of thermal expansion. This could lead to the disc contracting less than the body during cooldown (after closure), causing thermal binding.

Regarding pressure locking, the bonnet of the valve can be pressurized without flexing the disc. In addition, increasing the upstream pressure could lift the disc off the seat slightly, causing leakage. Recommended solutions for pressure locking included disc drilling, bonnet pressure vents, and external bypass lines from bonnet to body.

The vendor suggested that the licensees identify susceptible valves and provide more operational data so that additional engineering effort can be focused on these problems.

VENDOR ACTIONS - VELAN (John Farrell, Velan, see Enclosure 12)

One remedial solution proposed for thermal binding was to periodically cycle the valve as it cooled down, preventing the building up of stresses. Also, insulated valves may experience less temperature change, resulting in lower binding forces. Velan believes thermal binding can be caused by disc expansion, not just differential contraction of the body/disc. Therefore, they re-analyzed the wedge design, leading to design changes. They reduced the amount of material in the wedge (while still meeting ASME Code requirements), which significantly reduced the forces caused by thermal binding.

NRC DRAFT GENERIC COMMUNICATION ON PRESSURE LOCKING AND THERMAL BINDING (Tom Scarbrough, NRR, see Enclosure 13)

The proposed generic communication on pressure locking and thermal binding was discussed. The current proposal is not restricted to motor-operated valves, but also includes power operated valves. Manual valves could also be a concern, though there are few safety related manual valves.

Concerns were expressed regarding the reliability of the Grand Gulf methodology in justifying valve operability because the licensee's validation

only included tests on one valve. Any licensee utilizing this analytical approach will need to consider validation testing.

QUESTION AND ANSWER SESSION

The panel session to address questions, scheduled for the end of the day, was not necessary, as the participants had asked questions of each speaker during the presentations.

CLOSING REMARKS

Jack Rosenthal thanked the over 300 industry representatives attending the workshop for their enthusiastic participation. He stated that a NUREG will be prepared by AEOD to discuss the workshop, and should be issued this spring.

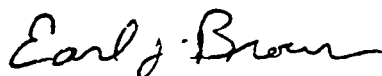

Earl J. Brown, Chief, Engineering Section
Reactor Operations Analysis Branch
Division of Safety Programs
Office for Analysis and Evaluation
of Operational Data



Allen G. Hansen, Project Manager
Project Directorate III-3
Division of Reactor Projects III/IV/V
Office of Nuclear Reactor Regulation

Enclosures: As stated

cc: List of Participants

Public Workshop Meeting Agenda

(Enclosure 1)

PUBLIC WORKSHOP MEETING AGENDA — FEBRUARY 4, 1994

GATE VALVE PRESSURE LOCKING AND THERMAL BINDING

WELCOME AND INTRODUCTION Jack Rosenthal, AEOD, and John Hannon, NRR	8:00 a.m.
PRESSURE LOCKING AND THERMAL BINDING ISSUES Earl Brown and Chuck Hsu, AEOD	8:15 a.m.
LICENSEE EXPERIENCE AND EFFORTS Dana Smith — Entergy, Grand Gulf Identifying susceptible valves, tests to confirm thrust levels during pressure locking, corrective actions	9:15 a.m.
Nabil Schauki — Siemens Power Corporation International experience, corrective action	9:40 a.m.
BREAK	10:00—10:15 A.M.
Mark Dowd — Commonwealth Edison, LaSalle Identifying susceptible valves, steam system pressure locking, combined pressure locking/thermal binding	10:15 a.m.
Dick Kadlec — American Electric Power, D.C. Cook Efforts to alleviate pressure locking at D.C. Cook	11:15 a.m.
Bill Rowlett — Entergy, Arkansas Nuclear One Jim Warren — Gilbert Commonwealth RHR valve sequencing to lessen pressure locking; pressure locking/thermal binding review at ANO	11:45 a.m.
LUNCH	12:15—1:15 P.M.
VALVE VENDOR CORRECTIVE ACTIONS Ike Ezekoye — Westinghouse Electric Corp. Design modifications to alleviate pressure locking	1:15 p.m.
Drew Wright — Anchor Darling Corrective actions to address pressure locking	1:45 p.m.
John Farrel — Velan Thermal binding test and analysis	2:15 p.m.
NRC DRAFT GENERIC COMMUNICATION Tom Scarbrough, NRR	2:45 p.m.
BREAK	3:15—3:30 p.m.
QUESTION AND ANSWER SESSION All presenters as panel	3:30 p.m.
CLOSING REMARKS Jack Rosenthal, AEOD, and John Hannon, NRR	4:45 p.m.

List of Meeting Participants

(Enclosure 2)

William Pegg
USNRC, Region III
801 Warrenville Rd.
Lisle, IL 60532

Peter Wohld
Chicago Nuclear
2 South 580 Ashley Dr.
Glen Ellyn, IL 60137

Clive Callaway
NUMARC
1776 Eye St. NW Suite 300
Washington, DC 20006

Chris Makowka
Duquesne Light Co.
BVPS - SEB-3
PO Box 4
Shippingport, PA 15077

Larry Dipzinski
Bell Engineering Corp.
335 East Main Street
Rochester, NY 14604

Ray N. Johnson
The Atlantic Group
5426 Robin Hood Road
Norfolk, VA 23513

Terry L. Jamerson
B&W Nuclear Tech.
155 Mill Ridge Rd.
Lynchburg, VA 24502

George Soukar
Consumers Power Company
Palisades Plant - NECO
27780 Blue Star Memorial HYW.
Covert, MI 49043

Jack Hoffman
Florida Power & Light
PO Box 14000
Juno Beach, FL 33408

Roger Eisner
Northeast Utilities
PO Box 270
Hartford, CT 06141

James F. Smith
USNRC, Region III
801 Warrenville Rd.
Lisle, IL 60532

Charlie Manges
Public Service Electric & Gas Company
PO Box 236
Hancocks Bridge, NJ 08038

George Johnson
USNRC
OWFN, MS 7E23
Washington, DC 20555

Steve Resch
Omaha Public Power District
444 S. 16th Street Mall
Omaha, NE 68102

Steve Coppock
Palo Verde Nuclear Generating Station
PO Box 52034, Mail Station 7494
Phoenix, Arizona 85072-2034

Hammie E. West
The Atlantic Group
5426 Robin Hood Road
Norfolk, VA 23513

Paul Babiuk
PECO Energy
Peach Bottom Atomic Power Station
RD#1 Box 208
Delta, PA 17314-9739

Ken Muller
Rochester Gas & Electric Corporation
89 East Ave.
Rochester, NY 14649

John E. Colvin
VECTRA
225 Scientific Drive
Norcross, GA 30092

Ray Main
Niagara Mohawk Power Corporation
PO Box 63
Lycoming, NY 13093

Steve Doty
Niagara Mohawk Power Corporation
P. O. Box 63
Lycoming, NY 13093

Jon Thorpe
Thorpe and Associates
484 Wedgefield Rd.
Granbury, Texas 76048-3848

C. Hsu
USNRC
Washington, DC 20555

Laurence M. Olson
Pennsylvania Power & Light Co.
Two North Ninth St.
Allentown, PA 18101

Mark R. Holbrook
EG&G Idaho, Inc.
2525 N. Fremont Ave.
Idaho Falls, ID 83401-3870

Rolly E. Fuller
Washington Public Power Supply
3000 George Washington Way
Richland, WA 99320

Robert A. Hall
Wyle Laboratories
Highway 20 West
Huntsville, AL 35807

James W. Kurtz
TVA
1101 Market St.
LP-SE
Chattanooga, TN 37402

Julie Turner
Carolina Power & Light Company
P. O. Box 1551 OHS-5
Raleigh, NC 27602

Ike Ezekoye
Westinghouse Electric Corp.
P. O. Box 355
Pittsburgh, PA 15230

Steve Pohl
Entergy Operations - ANO
Rt #3 Box 137G
Russellville, AR 72801

G. H. Weidenhamer
USNRC, MS 217B
Washington, DC 20555

Mark Dowd
Commonwealth Edison
LaSalle Station
RR 1
Marseilles, IL 61341

Bill R. Black
TU Electric
P. O. Box 1002
Glen Rose, TX 76043

Chris Myers
NRC
Region V
Mail Drop PE24
1450 Maria Lane
Walnut Creek, CA 94596--5368

Russ Colthorpe
NUS
2650 McCormick Dr., Suite 300
Clearwater, FL 34619

Brit B. Nauhria
P. O. Box 1551, OMS-5
Raleigh, NC 27602

Bob Poole
Sequoyah NP (TVA)
P. O. Box 2000
Soddy Daisy, TN 37379

Michael Casey
Carolina Power & Light Company
P. O. Box 1551
Raleigh, NC 27602

J. M. Farrell
VELAN Inc.
550 McArthur
Montreal, Quebec
H4T 1X8

Scott Bauer
Palo Verde Nuclear Generating Sta.
P. O. Box 52034 MS 7636
Phoenix, AZ 85072-2034

Michael Hooshmand
Palo Verde Nuclear Generating Sta.
P. O. Box 52034 MS 7494
Phoenix, AZ 85072-2034

Edward H. Smith
Palo Verde Nuclear Generating Sta.
P. O. Box 52034 MS 7636
Phoenix, AZ 85072-2034

Bob Whiting
Palo Verde Nuclear Generating Sta.
P. O. Box 52034 MS 7496
Phoenix, AZ 85072-2034

Mike Gregory
Palo Verde Nuclear Generating Sta.
P. O. Box 52034 MS 7494
Phoenix, AZ 85072-2034

A. Mayakwadi
Detroit Edison
45865, Sueffield
Novi, MI 48374

C. Cynoski
2 North St.
N. Welpole, NH 03609

Bruce Lord
P. O. Box 408
Wisasset, Maine 04578

O. J. Brouillette
Riverbend Station
P. O. Box 220
St. Francisville, LA 70775

James R. Salmon
Enercon Services, Inc.
Tulsa, OK 74146-3814

Charles Laverde
Con Edison
Indian Point #2
Broadway & Bleakely Ave.
Buchanan, NY 10511

Jeff Lomm
Con Edison
4 Irving Place
New York, NY 10019

Danny Chiou
Illinois Power Company
Clinton Power Station
P. O. Box 678
Clinton, IL 61727

John Puzauskas
Illinois Power Company
Clinton Power Station
P. O. Box 678
Clinton, IL 61727

George Levy
General Electric
175 Curtner Ave.
San Jose, CA 95125

Timothy G. Murray
Northeast Utilities
P. O. Box 270
Hartford, CT 06101

Peter A. Adamo
EBASCO Services Inc.
182 Shipman Drive
Glastonbury, CT 06033

Steve Greco
Wisconsin Electric Power Company
231 W. Michigan St.
Milwaukee, WI 53201

Brian Sullivan
Boston Edison Company
Pilgrim Nuclear Power Station
Rocky Hill Road
Plymouth, MA 02360

Drew Wright
Anchor/Darling Valve Company
701 First St.
Williamsport, PA 17701

Bill O'Connell
Consumers Power Company
Palisades Nuclear Power Station
27780 Blue Star Highway
Covert, MI 49043

Paul N. Carr
Toledo Edison Company
300 Madison Ave.
MS 3045
Toledo, OH 43652

Stephen L. Berry
WPPSS
P. O. Box 968
Richland, WA 99352

Yogesh C. Jain
Raytheon Engineers & Constructors
EBASCO Division
Two World Trade Center
New York, NY 10048

Tom Carroll
GPUN, PEB
Oyster Creek
P. O. Box 388
Forked River, NJ 08731

Ron Greiner
ITI MOVATS
2825 Cobb International Parkway
Kennesaw, GA 30144

Doug Steinsiek
Entergy Operations, Inc.
Riverbend Station
P. O. Box 220
St. Francisville, LA 70775

David Anderson
HMNIT
St. Peter's House
Balliol Rd.
Merseuside, L20 3LZ UK

Mike B. Pratt
Bechtel Power
1240 E. Diehl Rd.
Naperville, IL 60565

C. J. Dimarco
Entergy Operations Inc.
Waterford 3 SES
P. O. Box B
Killono, LA 70066-0751

Stan Hale
ITI MOVATS
2825 Cobb International Blvd.
Kennesaw, GA 30144-4352

Michael W. Green
Boston Edison
Pilgrim Station
Rocky Hill Road
Plymouth, MA 02360

James H. Correa
GPUN
1 Upper Pond Rd.
Parsippany, NJ 07054

Pat Wagner
GPUN, TMI-1
P. O. Box 480
Middletown, PA 17057

Ian M. Thomson
VECTRA
225 Scientific Drive
Norcross, GA 30092

Obaid Bhatti
TU Electric
P. O. Box 1002
Glen Rose, TX 76043

David P. Graham
Bechtel Power
1240 E. Diehl Rd.
Naderville, IL 60565

Yves Lassere
Commonwealth Edison
1400 Opus Rd.
Downers Grove, IL 60515

Jeff Daise
PECO Energy
965 Chesterbrook Blvd.
Wayne, PA 19087

T. F. Westerman
USNRC, Region IV
611 Ryan Plaza, Suite 400
Arlington, TX 76034

Ray Main
Niagara Mohawk
P. O. Box 63
Lycoming, NY

Bob Thweatt
Entergy (ECH-36)
P. O. Box 31995
Jackson, MS 39286-1995

Butch Hollowsa
Entergy - ANO
Rout 3
P. O. Box 137G
Russellville, AR 72801

Brad Adams
Commonwealth Edison Co.
ETWIII, 1400 OPUS Pl. Suit 400
Downers Grove, IL 60515

Lanny D. Ratzlaff
Wolf Creek Nuclear Operating Corp.
1550 Oxen Lane
Burlington, KS 66839

Roger Luechtefeld
Union Electric - Callaway Plant
P. O. Box 620
Fulton, MO 65251

William Kennedy
EPRI
3412 Hillview Ave.
Palo Alto, CA 94303

Fred Martsen
New York Power Authority
123 Main St.
White Plains, NY 10601

Nathan R. Kollengode
Niagara Mohawk Power Corp.
301 Plainfield Road
Salina Meadows #3
Syracuse, NY 13212

C. Y. Herschelman
Baltimore Gas and Electric
Calvert Cliffs Nuclear Power Plant
Lusby, MD 20657

Larry E. Schuerman
Detroit Edison - Fermi 2
6400 N. Dixie Highway
Newport, MI 48166

Ivan Beltz
Tenn. Valley Auth.
1101 Market St., LP4FC
Chattanooga, TN 37402

Brian Bunte
VECTRA Technologies
1333 Butterfield Rd
Suite 550
Downers Grove, IL 60515

Jay Ringler
Wisconsin Public Service
Kewaunee Nuclear Plant
N490, Hwy 42
Kewaunee, WI 54216-9510

Dave Heinlein
Union Electric - Callaway Plant
P. O. Box 620
Fulton, MO 65251

Richard P. Potekhen
B&W Nuclear Technologies
Valve Services
P. O. Box 10935
Lynchburg, VA 24506-0935

Michael Plunket
EAS Entergy Services
33 College Hill Rd, Build 25F
Warwick, RI 02886

M. Offerte
Detroit Edison - Fermi 2
6400 N. Dixie Hwy
Newport, MI 48166

Bruce Harry
Crane Valves
Nuclear Operations
104 N. Chicago St
Joliet, IL 60431

Denver Atwood
Southern Nuclear
44 Invernes Center Parkway
Birmingham, AL 35242

David Koo
BW/IP International
2300 E. Vernon Ave
Vernon, CA 90058

John R. Araold
CECo
Quad Cities 1 and 2
22710 205th Ave N.
Cordova, IL 61272

Lora Polley
Prairie Island Nuclear Plant
1717 Wakanade Dr. E
Welch, MN 55089

Vic Varma
EPRI/NMAC
1300 Harris Blvd.
Charlotte, NC 28262

Keith Matthews
Oconee Nuclear Site
P. O. Box 1439
Mail Code ONOICP
Seneca, SC 29679

Marvin Morris
Omega Technical Service, Inc.
Rout 5, P. O. Box 265
Russellville, AR 72801

Ken Kmetz
Enercon Services Inc.
1600 Parkwood Cir., Suite 600
Atlanta, GA 30339

Jan Grammer
Pacific Gas and Electric
DCPP System Engr.
P. O. Box 56
Avila Beach, CA 93424

Fred Tehranchi and Chuck Lynch
Southern Co. Services
P. O. Box 2625
Birmingham, AL 35202

Paul Brown
Yankee Atomic Electric Co.
580 Main Street
Bolton, Mass

Frank Cox
South Texas Project
P. O. Box 289
Wadsworth, TX 77483

Bill Nowicki
Calvert Cliffs
Nuclear Power Plant
1650 Calvert Cliffs Parkway
Lusby, MD 20657-4702

Rick Wirkkala
Prairie Island Nuclear Plant
1717 Wakanade Dr. E
Welch, MN 55089

Keith Peterson
Monticello Nuclear Gen. Plant
2807 W. Highway 75
Monticello, MN 55362

Patrick Cusick
Public Service Electric and Gas
Company of N.J.
P. O. Box 236 Mail Code 502
Hancocks Bridge, NJ 08038-0236

Ed Blackburn
Anchor/Darling Valve Co.
1700 Colonade Rd
Knoxville, TN 37922

Bob Whitsell
Pacific Gas and Electric
DCPP
P. O. Box 56
Avila Beach, CA 93424

Gene Talton
Southern Nuclear
P. O. Box 1295
Birmingham, AL 35201

Art Wiese
Nebraska Public District
1414 15th Street
Columbus, NC 68601

Klemme L. Herman
Pacific Gas & Electric Co.
333 Market Street A1103
San Francisco, CA 94106

Ravi B. Goel
Pacific Gas & Electric Co.
333 Market Street A1168
San Francisco, CA 94106

Joel Terry
ITI MOVATS Inc.
2825 Cobb International Blvd.
Kennesaw, GA 30144

S.N. Shields
Atwood & Morrill Co., Inc.
285 Canal Street
Salem, MA 01970

John Dempsey
Commonwealth Edison
Zion Generating Station
101 Shiloh Blvd
Zion, IL 60099

Victor Barbero
Iberdrola
Goya 4
28001-Madrid
Spain

Alan J. Tucker
Entergy Operations, Inc.
Waterford 3
Operations/STA Department
P.O. Box 833
Killono, LA 70043

Lia Georgopoulos
EMS Inc.
1401 Branding Lane
Suite 286
Downers Grove, IL 60515

Peter Beckham
Pacific Gas & Electric Co.
333 Market Street A7088
San Francisco, CA 94106

Robert Brauson
Commonwealth Edison
4450 N. German Church Road
Byron, IL 61010

Robert Brennam
Atwood & Morrill Co.
285 Canal Street
Salem, MA 01970

Roger Carr
ITI MOVATS Inc.
2825 Cobb International Blvd
Kennesaw, GA 30144

Wilhelm Muser
Siemens/KWU
Berlinerstr 295-303
60367 Offenbach, Germany

Jassam J. Francis
Detroit Edison
Fermi 2. 240 Tac
6400 N. Dixie Hwy.
Newport, MI 48166

Kevin Campbell (C2F)
Florida Power Corporation
3201 34th St. South
St. Petersburg, FL 33733

Clifford J. McDonald
Iowa Electric Light & Power
3277 DAEC Road
Palo, IA 62324

Louis A. Santilli
Florida Power Corp.
15760 Powerline Road - NW2B
Crystal River, FL 34428

Steve Wellsfy
WPPSS
3000 George Washington Way
Richland, WA 99352

Meena Khanna
U.S. NRC MS 0-7 E23
Washington, DC 20555

Dana Smith
Entergy Operations - Grand Gulf
P.O. Box 756
Port Gibson, MS 39150

John Manso
Florida Power & Light
P.O. Box 14000 - JPNIBB
Juno Beach, FL 33408

Scott McComas
Florida Power & Light
St. Lucie Plant
P.O. Box 128
Ft. Pierce, FL 34954-0128

Brian Wohlers
Iowa Electric Light & Power
3277 DAEC Road
Palo, IA 52324

Alan M. Stern
Florida Power Corporation
15760 Powerline Road NW2B
Crystal River, FL 34428

Chris Bajwa
U.S. NRC MS 0-13 D18
Washington, DC 20555

Deane C. Beck
ENER Tech
2950 Brich Avenue
Brea, CA 92621

James M. Warren
Gilbert/Commonwealth
1055 Commerce Park Drive
Suite 200
Oak Ridge, TN 37801

Troy Leaf
Byron-CECO
4450 N. German Church Road
Byron, IL 61010

Stuart Scow
Arizona Public Service Co.
P.O. Box 53999
Station 7997
Phoenix, AZ 85072-3999

E.H. Girard
U.S. NRC, Region III
101 Marietta Street
Suite 2900
Atlanta, GA 30323

Al Widmer
Cleveland Electric Illuminating Co.
Perry Nuclear Power Plant
10 Center road - A170
Perry, OH 44081

John Wolak
Virginia Power
Innsbrook Technical Center (IN1NW)
5000 Dominion Blvd
Glen Allen, VA 23060

Bill McDaniel
Mail Code - A10R
Pacific Gas & Electric Co.
P.O. Box 770000
San Francisco, CA 94177

Robert S. Lewis
PSE&G
P.O. Box 236 M/C N-50
Hancocks Bridge, NJ 08038

Yves A. Lassere
Commonwealth Edison Co.
1400 Opus Place
Suite 400
Downers Grove, IL 60515

John A. Tucker
Boston Edison Company
Pilgrim Nuclear Power Station
600 Rocky Hill Road
Plymouth, MA 02360

Roy Beger
Virginia Power
Innsbrook Technical Center (IN2SE)
500 Dominion Blvd.
Glen Allen, VA 23060

Lisa Borel
Entergy Operations, Inc.
River Bend Station
P.O. Box 220
St. Francisville, LA 70775

Michael M. Martin
205 Rhinefonta Drive
Churchville, MD 21028-1517

David P. Graham
Betchel Power
1240 E. Diehl Road
Naperville, IL 60565

William White
Entergy Operations
P.O. Box 756
Port Gibson, MS 39150

Paul Stanton
Entergy Operations, Inc.
Waterford 3
P.O. Box B
Killona, LA 70066

Ket Van Le
Entergy Operations, Inc.
Waterford 3
P.O. Box B
Killona, LA 70066

Bill Ross
Tu Electric Company
Mail Stop M35
P.O. Box 2300
Glan Rose, TX 76043

Kenneth F. Robinson
Baltimore Gas and Electric
Calvert Cliffs Nuclear Plant
1650 Calvert Cliffs Pkwy
Lusby, MD 20657-4702

Allen G. Hansen
U.S. NRC MS 0-13 E21
Washington, D.C. 20555

Ed Simbles
ERIN Engineering & Research
11757 Katy Fwry, St. 350
Houston, TX 77079

Kevin Fitzsimmons
Entergy Operations, Inc.
Waterford 3
P.O. Box B
Killona, LA 70066

John Jacobson
U.S. NRC, Region III
801 Warrenville Road
Lisle, IL 60532

Richard A. Kadlec, P.E.
American Electric Power
1 Riverside Plaza
Columbus, OH 43215

Daryl F. Cox
ORNL Martin Marietta Energy
Systems, Inc.
P.O. Box 2009
Oak Ridge, TN 37831-8038

Earl J. Brown
U.S. NRC MS T-4 A9
Washington, DC 20555

**Questions Received From Public in
Response to Federal Register Notice**

(Enclosure 3)

BAL-TECH

205 RHINEFORTE DRIVE, CHURCHVILLE, MARYLAND 21028-1517

December 31, 1993

U.S. Nuclear Regulatory Commission
Office of Nuclear Reactor Regulation
Washington, D.C. 20555

Dear Allen G. Hansen,

This letter is in response to the Notice of Meeting published in the Federal Register on November 29, 1993. To assist NRC in preparing for the meeting interested parties were requested to mail questions to NRC concerning potential pressure locking and thermal binding of gate valves installed in safety related systems at both boiling water and pressurized water reactors. Attached is a list of 34 questions.

We appreciate the opportunity to raise these questions, and look forward to your response to each at the public meeting.

Sincerely,



Michael M. Martin
Senior Engineer

**ATTACHMENT
QUESTIONS**

Pressure Locking and Thermal Binding

1. Are only valves mounted with stems horizontal or oriented so that the valve bonnet is below the valve body susceptible to pressure locking?
2. Are valves mounted with the stem vertical not susceptible to pressure locking?
3. Was pressure locking caused by an increase in ambient temperature in any of the cases studied by the AEOD? If so, which case?
4. Has pressure locking been caused by an increase in ambient temperature in any case of which NRC is aware? If so, when and where?
5. Was pressure locking caused by an increase in system fluid temperature in any system that is not used to remove core decay heat in any of the cases in the AEOD study? If so, which case?
6. Was pressure locking caused by an increase in system fluid temperature in any system that is not used to remove core decay heat in any cases of which NRC is aware? If so, when and where?
7. Was the pressure locking event caused by an increase in fluid temperature in the Residual Heat Removal System at a BWR, and documented in the AEOD study, a safety concern? Was the valve that pressure locked required to be operable in the plant mode of operation in which the valve was found to be pressure locked?
8. Were the pressure locking events caused by an increase in fluid temperature in the Residual Heat Removal System at PWRs, and documented in the AEOD study, a safety concern? Were the valves that pressure locked required to be operable in the plant mode of operation in which the valve was found to be pressure locked?

BAL-TECH

205 RHINEFORTE DRIVE, CHURCHVILLE, MARYLAND 21028-1517

9. Did all the AEOD study documented cases of differential pressure locking occur post hydrostatic testing? If not, which case?

Note: Differential pressure locking is described in SOER 84-07, Page 6.

10. Are the AEOD documented cases, which are due to hydrostatic testing, at a significantly higher pressure than the pressure available from the process fluid system? If not, which case?
11. Did any differential pressure locking cases occur, of which NRC is aware, which did not occur post hydrostatic testing? If so, when and where?
12. NRC recommends valve modifications and appropriate procedures to prevent binding from occurring in the AEOD study. Are actuator modifications also a reasonable means to prevent binding? If not, why not?
13. Is there any available NRC accepted calculational methodology in use to determine the amount of thrust required to unseat a pressure locked valve? If so, please provide a reference. If not, why not?
14. Is the calculational method provided in Sections 2.1 through 2.4 and Section 5.2 of NUREG/CR-5807, a valid methodology to find the amount of thrust required to unseat a pressure locked valve? If not, why not?
15. For a flex wedge gate valve, may the double disk drag forces in Section 5.2 of NUREG/CR-5807 be reduced to account for the decreased surface area of the valve inside disk due to the disk hub, and remain a valid calculation? If not, why not?
16. For cold water systems (less than 200 degrees F), may a flex- wedge gate valve disk to seat coefficient of friction of 0.4 be used for each valve disk if a significant amount of preconditioning has not been performed? If not, why not?
17. May a significant amount of preconditioning be defined as more than 100 full strokes within a one year period? If not, why not?

BAL-TECH

205 RHINEFORTE DRIVE, CHURCHVILLE, MARYLAND 21028-1517

18. Is pressure locking a concern only when steam is introduced into a previously hydrostatically tested steam system before proper draining?
19. For valves that are potentially susceptible to pressure locking, if an actuator is used that can provide ten times the amount of thrust as the actuator that would normally be used, is the valve no longer a pressure locking concern? If not, why not?
20. How much greater actuator capability is required to assure a valve susceptible to pressure locking will not pressure lock? Why was this value picked?
21. Did any case of the AEOD study occur due to thermal binding of a gate valve where the component was required to be operational and a Technical Specification Action Statement not entered? If so, which case?
22. Is there any case of which NRC is aware where thermal binding of a gate valve occurred where the component was required to be operational and a Technical Specification Action Statement not entered? If so, where and when?
23. Is operating within the Action Statements of Technical Specifications operating within the safety design bases of the plant?
24. Is there any proposed physical modification of Containment Isolation Valves that does not jeopardize Containment Integrity (especially under low differential pressure, long term LOCA, conditions)? Do these modifications involve increased flowpaths or reduce the integrity of the present barriers that prevent radioactive materials from escaping to the environment?
25. Do proposed modifications comprise additional safety related equipment (ie. solenoid or relief valves) governed by Containment Isolation Criteria?
26. If valve bonnet relief or solenoid operated valves are used to physically modify susceptible valves, what setpoints should be considered for such equipment (See question 13)?

BAL-TECH

205 RHINEFORTE DRIVE, CHURCHVILLE, MARYLAND 21028-1517

27. Do all the proposed modifications increase the probability of contaminants being introduced into the reactor coolant system from the service water systems, condensate transfer systems, torus or containment sump? Note: Increased contaminants should be compared to normal makeup. For BWRs normal make up is from the condenser (deaerated), and the condensate and feedwater systems via the condensate demineralizers.
28. Have the analyses for recent events involving shroud cracking, reactor jet pump support degradation, or steam generator tube leaks, shown that contaminant intrusion by way of valve disk modifications for pressure locking, was not a significant contributor nor the root cause?
29. Is Intergranular Stress Corrosion Cracking a major safety concern at light water reactors?
30. Is Intergranular Stress Corrosion Cracking promoted by oxygen and contaminants, notably chlorides?
31. Is intrusion of organic contaminants more of a safety concern than pressure locking?
32. Is making modifications to valves deemed potentially susceptible to pressure locking more of a safety concern than not making modifications? If not, why not?
33. Has AEOD/NRC considered other potential adverse affects of proposed gate valve pressure locking modifications? What, if any, are there?
34. Is NRC Information Notice 92-26 the only present regulatory document that requests that modifications be evaluated? If not, what others?

Pressure Locking and Thermal Binding Issues
Earl J. Brown and Chuck Hsu

Reactor Analysis Branch
Division of Safety Programs
Office for Analysis and Evaluation
of Operational Data
U.S. Nuclear Regulatory Commission

(Enclosure 4)

PRESSURE LOCKING AND THERMAL BINDING OF GATE VALVES

By

Earl J. Brown
Office for Analysis and Evaluation
of Operational Data
U.S. Nuclear Regulatory Commission
Washington, DC

INTRODUCTION

The United States Nuclear Regulatory Commission (USNRC) staff has reviewed several operating events involving pressure locking and thermal binding of gate valves. These events continue to occur even though several attempts were made by industry to address these problems. Therefore, the USNRC staff felt an exchange of technical information would be a constructive means to help people understand the issues involved. Thus, the Workshop was organized to address a broad scope of basic technical issues as well as event experience and reviews conducted at boiling water and pressurized water reactor plants. The meeting objectives are illustrated in Vugraph E-1. The plan is to discuss the special study issued as NUREG - 1275, Vol. 9; review the conditions and causes of the phenomena; discuss the role of components, systems, and plant operations; and then review specific events and corrective actions taken by plant staff and component vendors.

DISCUSSION

Vugraph E-2 illustrates the important issues covered in NUREG - 1275, Vol. 9. This study was initiated after submittal of licensee event report 333/91-014 which described a pressure locking event at the James A. Fitzpatrick plant. The study reviewed events back to 1977 and up to the early 1990's including the industry actions taken in 1984 and 1988. The report discusses the conditions which can cause the phenomena, repeats the industry recommended preventive measures, and discusses the consequences of such events. The primary concern is that large forces can develop across two discs rather than the single disc differential force used to size an operator. The safety significance is that this type of event represents a common-cause failure mechanism with the potential for failure of redundant safety trains or multiple safety systems. One important message is that the events cited in the report are examples of how conditions develop to cause gate valve pressure locking or thermal binding rather than examples of the most important safety-related valves that are susceptible to the phenomena.

The essential features involved in establishing pressure locking and thermal binding in gate valves (flexible wedge, double disc, and solid wedge) are shown in Vugraph E-3 with a valve cross-section shown in Vugraph E-4. Pressure locking can occur when a mechanism exists for the valve bonnet to fill with water. This may include simple valve open and close strokes,

differential pressure across the discs, or collection of condensate. The pressure source could be a temperature increase of the bonnet water volume, connection to a high pressure source, or residual bonnet pressure after a pipe line depressurization on the seat side of both discs. The depressurization aspect is a mechanism that would not require the bonnet to be filled with water. Vugraph E-5 illustrates an example of how pressure locking can develop due to sudden depressurization for a BWR low pressure injection system. The top sketch shows high bonnet pressure develops because reactor pressure is transmitted past the leaking check valve to the bonnet. The bottom sketch shows low pressure on the seat side of the valve discs after a large break loss of coolant accident. Thus, the opening force must overcome the differential pressure across both discs.

Some factors that influence occurrence of pressure locking or thermal binding are listed in Vugraphs E-6 and E-7. The factors include component, system, plant operations, and NSSS considerations. Although it is the component that fails to operate, one must understand component operation, system operation and conditions, plant operation and event sequence, and NSSS design characteristics that could affect valve response. This illustrates a team approach is necessary when attempting to identify susceptible valves. Based on discussions with licensee staff, use of the assumptions listed in Vugraph E-8 could easily mislead the effort to determine susceptible valves. In practice, it is a list of what not to do. The fact there is an absence of maintenance/operational problem history is not an indication the problems do not exist at the plant. In addition, a check valve may meet leakage requirements and still transmit pressure. Also, reviews that only include normal system operation, without considering the entire event sequence, are incomplete.

The safety system schematic diagrams shown in Vugraphs E-9, E-10, and E-11 are helpful to illustrate both examples of conditions that can cause pressure locking and the valves affected. A typical residual heat removal (RHR) system configuration for a Westinghouse PWR plant is shown in Vugraph E-9. Valves of interest include the containment sump suction valve, 184B, the hot leg injection valve, 183B, and RHR crosstie valves, 30A and 15B. In a large dry containment, the sump is usually dry, the suction valve is normally closed, and the valve is sized to open against maximum containment pressure plus the LOCA head for a total of about 75 psi (an ice condenser containment would have a pressure of about 20 psi). The mechanism to fill the bonnet is the valve exposure to reactor coolant pressure up to 400 psi during plant startup. After a LOCA, the hot water in the sump could heat the bonnet water with the potential to pressure lock the valve. The hot leg injection valve has a different mechanism to cause pressure locking. It is connected to the reactor coolant system (RCS) with separation via a single check valve. The valve is usually sized for low pressure operation several hours after a LOCA has depressurized the RCS; however, the bonnet could still retain RCS pressure. The RHR crosstie valves are normally open during plant operation, but after an accident they may close (this varies among plants) and may subsequently have to open for long term injection or as a path for hot leg injection. NUREG - 1275, Vol. 9 (Appendix A, Item E) cited pressure locking failure of these valves during a plant startup when they were closed with the water temperature cold but the valve was located close to the RHR pathway that became hot during startup. Thus, heat transfer via conduction and convection, heated the bonnet water and caused pressure locking. The situation after a LOCA is very similar to this scenario because these

valves are closed cold, the cold water is injected, and subsequent recirculation of hot sump water could heat the bonnet water.

Vugraph E-10 is a schematic for a BWR plant shutdown cooling system and E-11 is a schematic for a Combustion Engineering plant PWR containment spray system. The BWR plant configuration illustrates another example where valve proximity to a flowpath that became hot after being cold caused pressure locking. The suppression pool suction valves, 4A and 4B, are normally open during plant operation to be aligned for injection if needed. During shutdown cooling, the valves are closed. NUREG -1275, Vol. 9 (Appendix A, Item G) cites an event where the valve became pressure locked after it was closed with the suppression pool temperature at 75 °F and with a reactor coolant temperature at 175 °F in a connected pipe flowpath. The PWR containment spray system and low pressure safety injection system have a common path such that the spray valves, 305A and 306B, could be subjected to RCS pressure during plant startup. This could cause a high bonnet pressure with potential pressure locking under containment spray conditions.

SUMMARY

The USNRC staff discussed these issues with licensee representatives of more than 30 plants. Based on that information and separate staff reviews, we identified some system valves that are exposed to conditions or event scenarios which could make them potentially susceptible to pressure locking. A list of potentially susceptible valves by plant type (NSSS) is shown in Vugraphs E-12 (BWR), E-13 (PWR - Westinghouse), E-14 (PWR - Babcock & Wilcox), and E-14 (PWR - Combustion Engineering) respectively. This should not be considered an all inclusive list. In fact, our discussions with licensee staff revealed each plant has specific aspects involving design, configuration, alignments, and plant operations that would affect the potential valve susceptibility to pressure locking or thermal binding. Thus, although a possible generic list of susceptible valves may be developed, one should also expect there are some valves "unique" to each plant. We observed that an interdisciplinary team approach including staff expertise in components, systems, and operations was very successful in identifying valves susceptible to pressure locking or thermal binding.

PRESSURE LOCKING AND
THERMAL BINDING OF GATE VALVES



NEW ORLEANS, LOUISIANA
FEBRUARY 4, 1994

EARL J. BROWN, AEOD

OBJECTIVES

- PRESSURE LOCKING AND THERMAL BINDING HISTORY
 - NUREG-1275, VOL. 9
 - FLEXIBLE WEDGE, SPLIT WEDGE, DOUBLE DISC
 - SOLID WEDGE
- PHENOMENA
- COMPONENTS, SYSTEMS, OPERATIONS, NSSS
- OPERATING EXPERIENCE AND PREVENTIVE METHODS

NUREG-1275, VOL. 9

- **PRESSURE LOCKING AND THERMAL BINDING HISTORY**
- **TECHNICAL ASPECTS OF PHENOMENA**
- **PREVENTIVE MEASURES**
- **CONSEQUENCES**

PRESSURE LOCKING AND THERMAL BINDING PHENOMENA

- PRESSURE LOCKING (FLEXIBLE WEDGE, DOUBLE DISC)
 - FLUID SOURCE TO FILL BONNET
 - OPEN/CLOSE
 - DIFFERENTIAL PRESSURE ACROSS DISC
 - CONDENSATE
 - PRESSURE SOURCE
 - CONNECTION TO HIGH PRESSURE SOURCE
 - BONNET VOLUME TEMPERATURE INCREASE
- THERMAL BINDING (SOLID WEDGE, OTHERS)
 - CLOSE HOT/OPEN COLD
 - TEMPERATURE GRADIENT ACROSS DISC
- CONTRIBUTORS TO STEM THRUST

Pressure Locking Flexible-Wedge Gate Valve

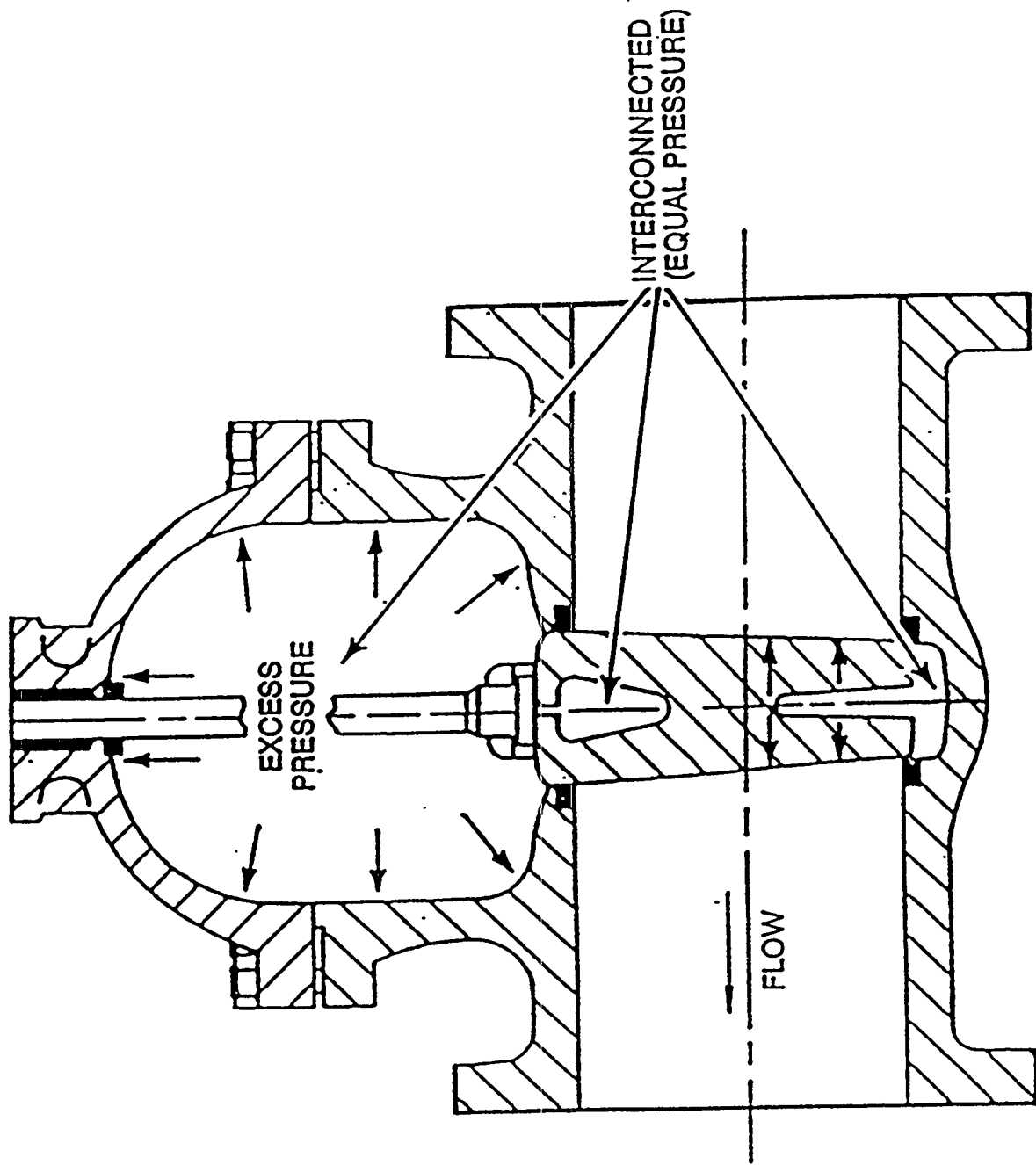

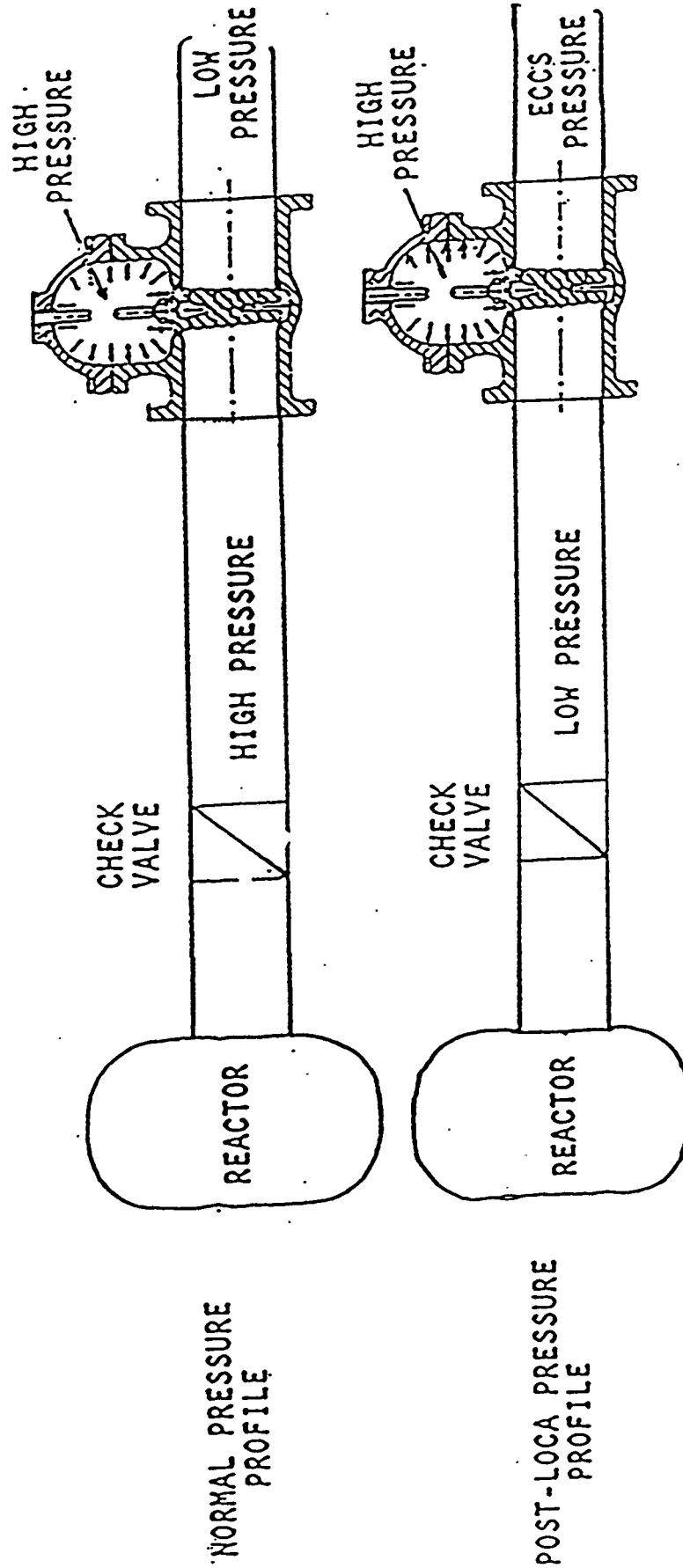

BWR LOW PRESSURE SAFETY INJECTION

FACTORS INFLUENCING OCCURRENCE

- COMPONENT
 - DESIGN CHARACTERISTICS
 - TOLERANCE
- SYSTEM
 - PRESSURE, TEMPERATURE
 - CONNECTING SYSTEM
 - OPERATING CONDITIONS AND WHEN

FACTORS INFLUENCING OCCURRENCE (CONT.)

- PLANT OPERATIONS
 - PRESSURE, TEMPERATURE
 - VALVE OPEN/CLOSE, WHEN, HOW LONG
- NSSS
 - PLANT TYPE (BWR, PWR, ETC.)
 - CONSTRUCTION YEAR
 - CONTAINMENT TYPE

PLANT VISITS

ASSUMPTIONS PREVENTING IDENTIFICATION OF SUSCEPTIBLE VALVES

- **NO MAINTENANCE/OPERATIONAL HISTORY OF PROBLEM**
- **LEAKAGE PAST IN-LINE CHECK VALVE ASSUMED TO BE ZERO**
- **REVIEW NORMAL SYSTEM OPERATION ONLY**

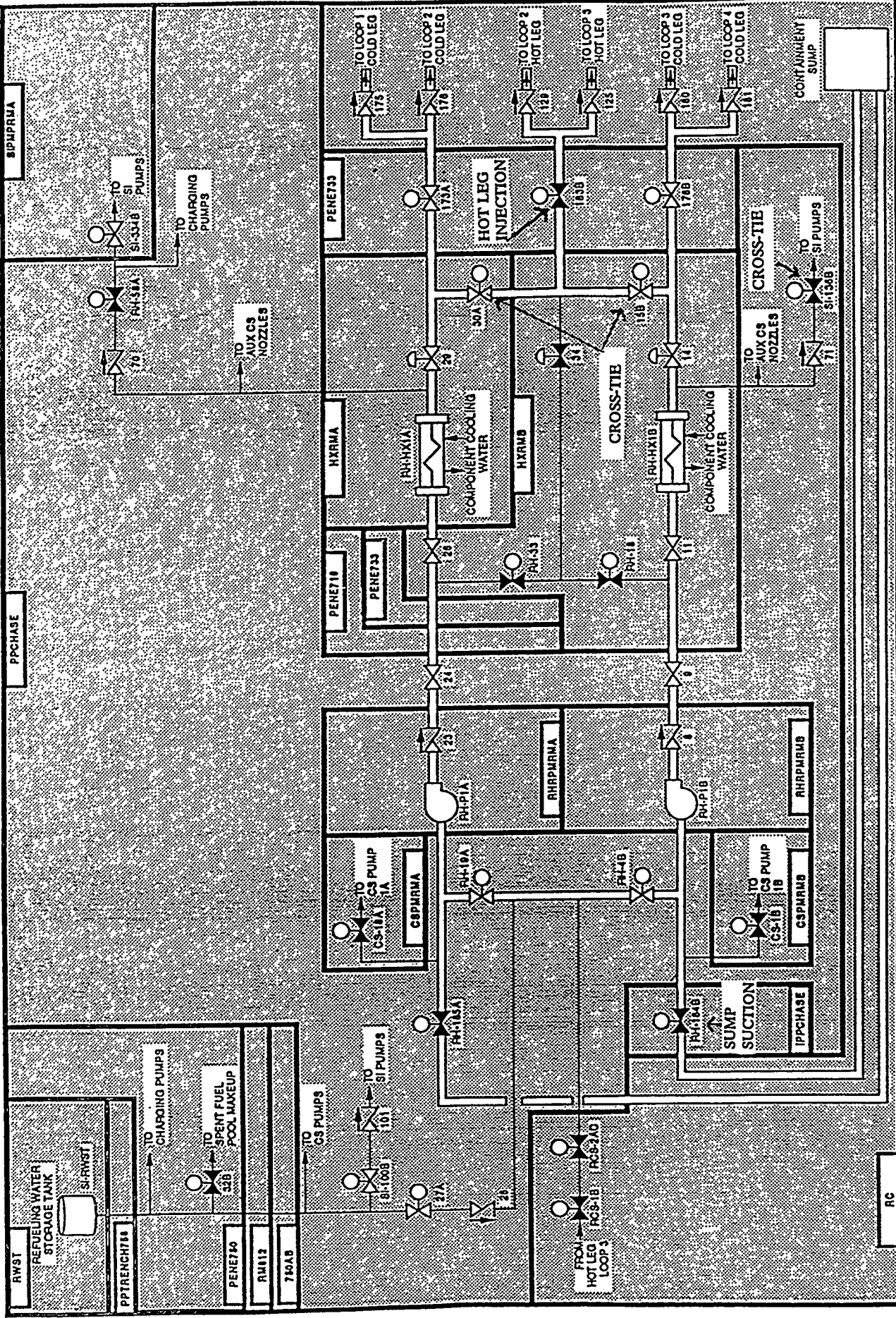

RESIDUAL HEAT REMOVAL SYSTEM

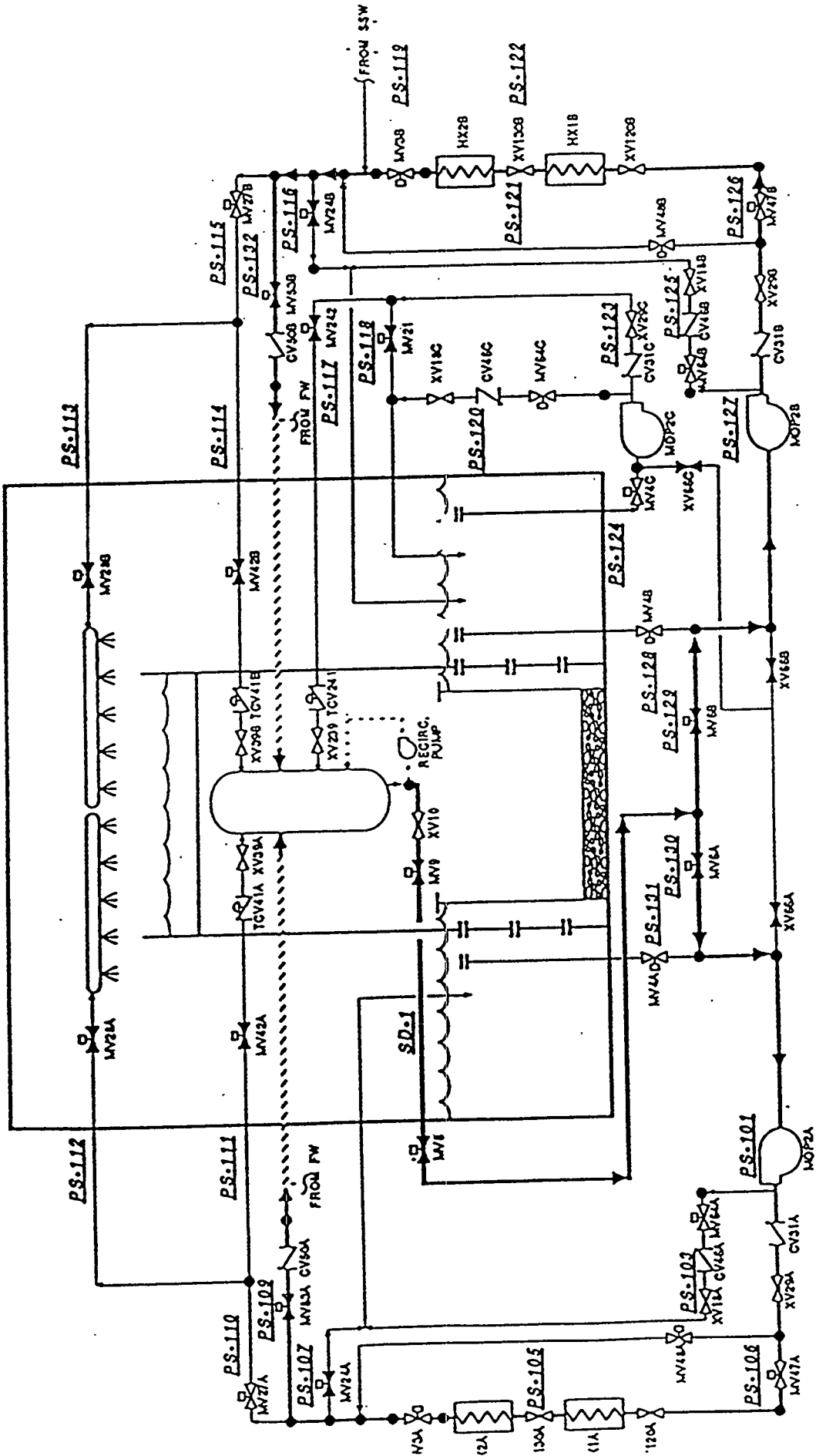

VALVE POSITIONS ARE SHOWN IN THEIR STANDBY MODE

BWR SHUTDOWN COOLING

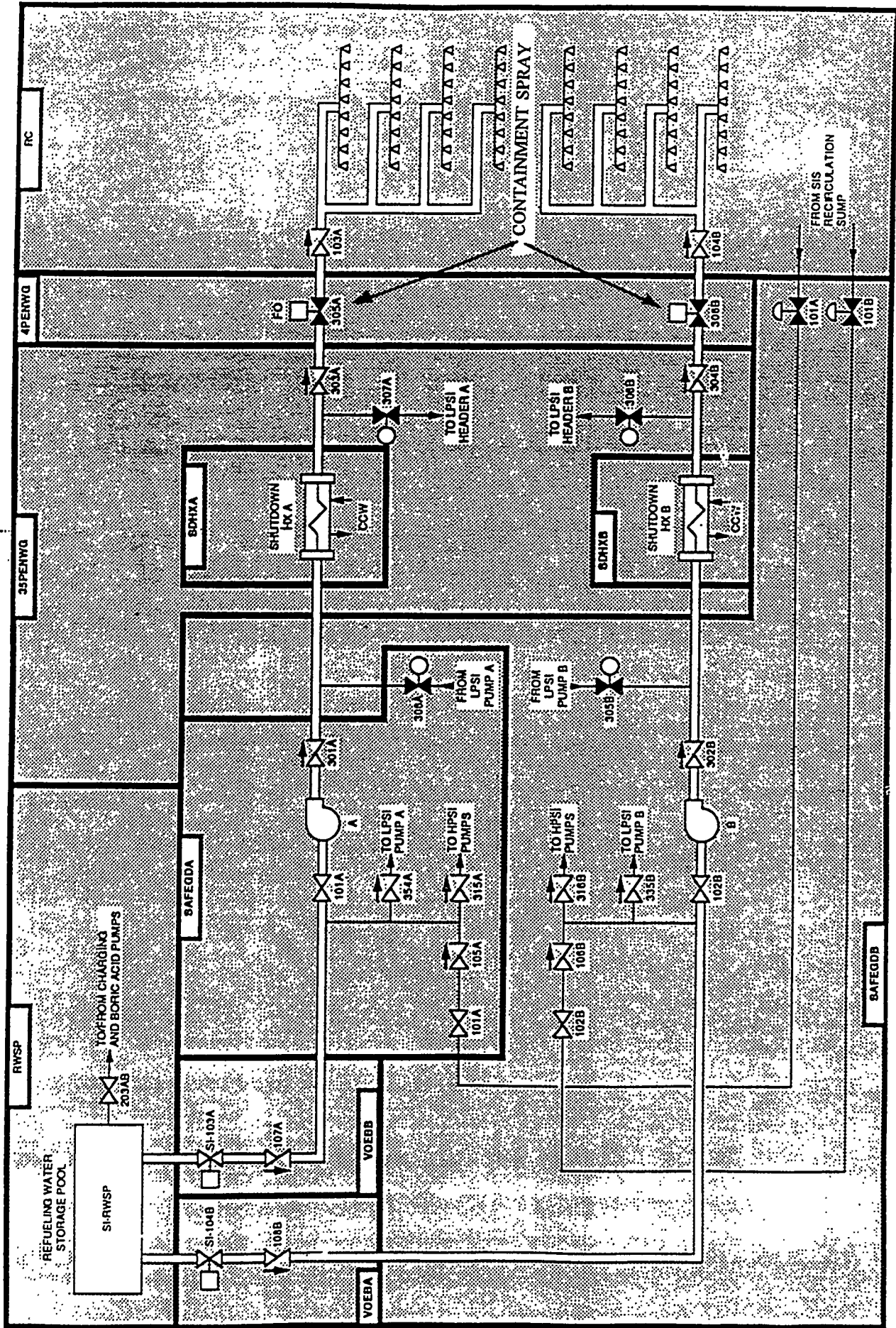

PWR CONTAINMENT SPRAY

SAFETY SIGNIFICANT SUSCEPTIBLE VALVES

- BWRS
 - LOW PRESSURE
 - LPCI, LPCS (INJECTION) — LEAKING CHECK VALVES
 - RHR MODES — REPOSITION VALVES
 - HIGH PRESSURE
 - HPCI, HPCS (INJECTION) — LEAKING CHECK VALVES
 - HPCS (SUCTION) — CONDUCTION HEATUP
 - HPCI, RCIC (STEAM ADMISION) — ORIENTATION, CONDENSATE

SAFETY SIGNIFICANT SUSCEPTIBLE VALVES

- **PWR — WESTINGHOUSE**
 - **LOW PRESSURE**
 - **CONTAINMENT SUMP (SUCTION) — BONNET FILLED, HEATUP DURING LOCA**
 - **HOT LEG INJECTION — LEAKING CHECK VALVE**
 - **DECAY HEAT REMOVAL (COLD SHUTDOWN PLANT) — RCS PRESSURE**
 - **ECCS CROSS-CONNECT/RECIRCULATION — RCS PRESSURE**
 - **HIGH PRESSURE**
 - **PORV BLOCK VALVE — CLOSED DURING OPERATION, FEED AND BLEED**

SAFETY SIGNIFICANT SUSCEPTIBLE VALVES

- **PWR — BABCOCK & WILCOX Co.**
- **LOW PRESSURE**
- **CONTAINMENT SUMP (SUCTION) — BONNET FILLED, HEATUP DURING LOCA**
- **VALVES FOR BORON PRECIPITATION — LEAKING CHECK VALVES**
- **DECAY HEAT REMOVAL (COLD SHUTDOWN PLANT) — RCS PRESSURE**
- **LPCI (INJECTION) — LEAKING CHECK VALVES**
- **ECCS CROSS-CONNECT — LEAKING CHECK VALVES**
- **HIGH PRESSURE**
- **PORV BLOCK VALVE — CLOSED DURING OPERATION, FEED AND BLEED**
- **AFW (INJECTION) — LEAKING CHECK VALVES**
- **AFW (ADMISSION) — ORIENTATION, CONDENSATE**

SAFETY SIGNIFICANT SUSCEPTIBLE VALVES

- PWR — COMBUSTION ENGINEERING (MOST CLOSED VALVES ARE GLOBE)
 - LOW PRESSURE
 - CONTAINMENT SUMP (SUCTION) — BONNET FILLED, HEATUP DURING LOCA
 - DECAY HEAT REMOVAL (COLD SHUTDOWN PLANT) — RCS PRESSURE
 - ECCS CROSS-CONNECT — LEAKING CHECK VALVES (NOT ALL PLANTS)
 - HIGH PRESSURE
 - PORV BLOCK VALVE — CLOSED DURING OPERATION, FEED AND BLEED
 - AFW (INJECTION) — LEAKING CHECK VALVES
 - AFW (STEAM ADMISSION) — ORIENTATION, CONDENSATE
 - CONTAINMENT SPRAY — BONNET FILLED DURING STARTUP

Industry Experience and Efforts

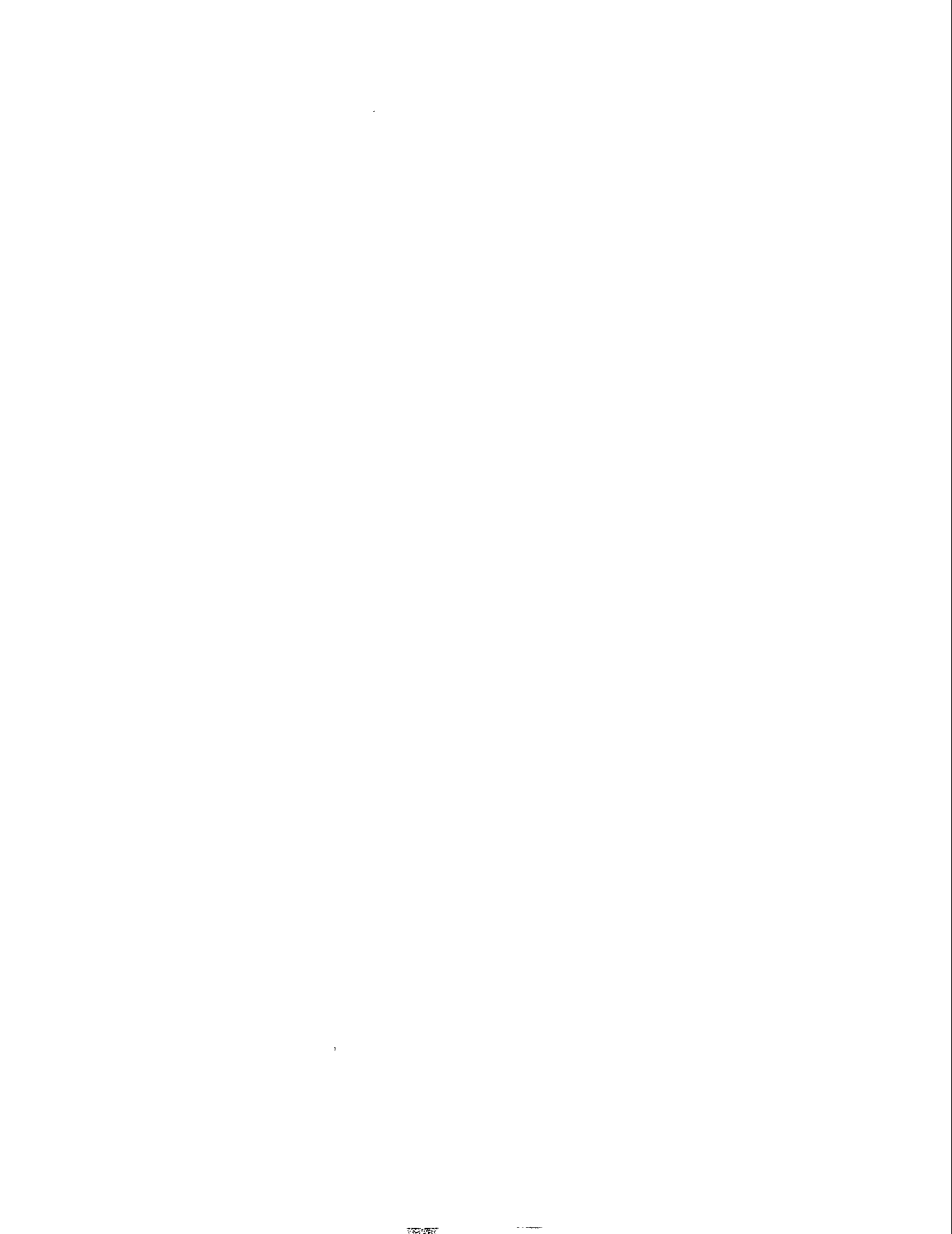

**Licensee Experience
Dana Smith, Entergy Operations Inc.**

**Grand Gulf Nuclear Station
Port Gibson, MS**

(Enclosure 5)

CALCULATION TO PREDICT THE REQUIRED THRUST TO OPEN A FLEXIBLE WEDGE GATE VALVE SUBJECTED TO PRESSURE LOCKING

by

Dana E. Smith, P.E.

**Entergy Operations Inc.
Grand Gulf Nuclear Station
Port Gibson, MS**

ABSTRACT

The ability to predict the thrust requirement for gate valves is essential to any program evaluating the phenomena of pressure locking. This presentation depicts the process used by Grand Gulf Nuclear Station (GGNS) personnel in developing and validating a calculational approach for predicting thrust.

The essential aspects of any calculation include sound engineering principles and independent verification of the results. It should be noted the validation testing focused on a specific set of parameters rather than simulating all possible scenarios.

Based on the results of the validation testing, GGNS concludes the methodology to be sound, but with certain limitations.

OVERVIEW

GGNS has experienced and postulated pressure locking of flexible wedge gate valves. To aid in the analysis of the pressure locking phenomena, a calculation was required. This calculation represents the methodology developed at GGNS to predict the associated thrust requirements. The calculation is divided into two separate areas: pressure loads and unwedging loads. The pressure loads are calculated based on engineering first principles. The load cases modeled assume the flexible discs of the wedge act as flat, circular plates of uniform thickness. The tensile effects of the disc hub result in an overall reduction of reaction loads. Stem ejection loads (piston effects) and packing loads are assumed to be negligible, being approximately equal in magnitude and opposite in direction. The unwedging loads are based on the previous closing cycle. This calculation conservatively quantifies the unwedging force based upon calculated closing thrusts or actual test data under static conditions.

To validate the calculation methodology, GGNS contracted Wyle Labs in Huntsville, AL to perform testing. A 14-inch 900# William Powell flexible wedge gate valve was tested. The valve was instrumented to record pressure and stem thrust. The valve was configured such that pressure could be applied upstream, downstream or between the discs, in any combination. The valve did not receive any maintenance to assure leak tightness of the seats, which was observed to be zero. Testing was performed to simulate postulated LPCI injection valve requirements, and results were within 3% of calculated results. All stated assumptions of the calculation, including an initial friction factor, were validated.

GGNS accepts the methodology as an appropriate means to estimate required stem thrust for pressure locking scenarios. The calculation accurately predicts pressure loading; however, there is no method to accurately predict the unwedging load. GGNS has conservatively added the entire static unwedging load to some evaluations. As evidenced by the Wyle testing this is conservative for disc differential pressures from 100% to approximately 65%, as defined by $(\text{bonnet pressure} - \text{line pressure}) / \text{bonnet pressure}$. Experience has shown as the disc differential pressures decrease, so do the unwedging loads. Additional testing should be performed to quantify the reduction of the unwedging loads as differential pressure decreases.

**Calculation to Predict the Required Thrust
to Open a Flexible Wedge Gate Valve
Subjected to Pressure Locking**

Prepared by
Dana E. Smith

Entergy Operations Inc.
Grand Gulf Nuclear Station
P.O. Box 756
Port Gibson, MS 39150

Prepared for
NRC Public Meeting
February 4, 1994
New Orleans, LA

1.0 PURPOSE

The purpose of this calculation is to determine the normal force on the seat ring of a valve for the potential pressure locking conditions so as to determine the total required stem thrust to open the valve.

2.0 REFERENCES

- 2.1 Formulas for Stress and Strain, Roark and Young, 6th Edition.
- 2.2 NUREG/CR-5807, Improvements in Motor Operated Gate Valve Design and Prediction Models for Nuclear Power Plant Systems, Wang and Kalsi, May 1992.

3.0 ASSUMPTIONS

- 3.1 The flexible discs act like two uniform thick, flat circular plates with a fixed hub connection at the center.
- 3.2 The analysis will be broken down into four load cases and then numerically added together.
- 3.3 The high side pressure loads on the hub area will be transferred directly to the low side disc.
- 3.4 As stated in the body of the calculation.

4.0 CALCULATIONS

The internal pressure will be analyzed using Ref. 2.1 Table 24 Case 2d. This will provide the force exerted on the seat ring by the disc with the internal pressure. This analysis will use the following equations and values and is performed in an Excel spreadsheet.

- 4.1 Force on the perimeter of the disc hub (Q_b) (Case 2d)

$$Q_b = qa \frac{C_2 L_{17} - C_8 L_{11}}{C_2 C_9 - C_3 C_8}$$

where

$$C_2 = \frac{1}{4} \left[1 - \left(\frac{b}{a} \right)^2 \left(1 + 2 \ln \frac{a}{b} \right) \right]$$

$$C_3 = \frac{b}{4a} \left\{ \left[\left(\frac{b}{a} \right)^2 + 1 \right] \ln \frac{a}{b} + \left(\frac{b}{a} \right)^2 - 1 \right\}$$

$$C_8 = \frac{1}{2} \left[1 + \nu + (1 - \nu) \left(\frac{b}{a} \right)^2 \right]$$

$$C_9 = \frac{b}{a} \left\{ \frac{1 + \nu}{2} \ln \frac{a}{b} + \frac{1 - \nu}{4} \left[1 - \left(\frac{b}{a} \right)^2 \right] \right\}$$

$$L_{11} = \frac{1}{64} \left\{ 1 + 4 \left(\frac{r_o}{a} \right)^2 - 5 \left(\frac{r_o}{a} \right)^4 - 4 \left(\frac{r_o}{a} \right)^2 \left[2 + \left(\frac{r_o}{a} \right)^2 \right] \ln \frac{a}{r_o} \right\}$$

$$L_{17} = \frac{1}{4} \left\{ 1 - \frac{1 - \nu}{4} \left[1 - \left(\frac{r_o}{a} \right)^4 \right] - \left(\frac{r_o}{a} \right)^2 \left[1 + (1 + \nu) \ln \frac{a}{r_o} \right] \right\}$$

Force on the perimeter of the disc (Q_a) at the seat ring

(Case 2d)

$$Q_a = Q_b \frac{b}{a} - \frac{q}{2a} (a^2 - r_o^2)$$

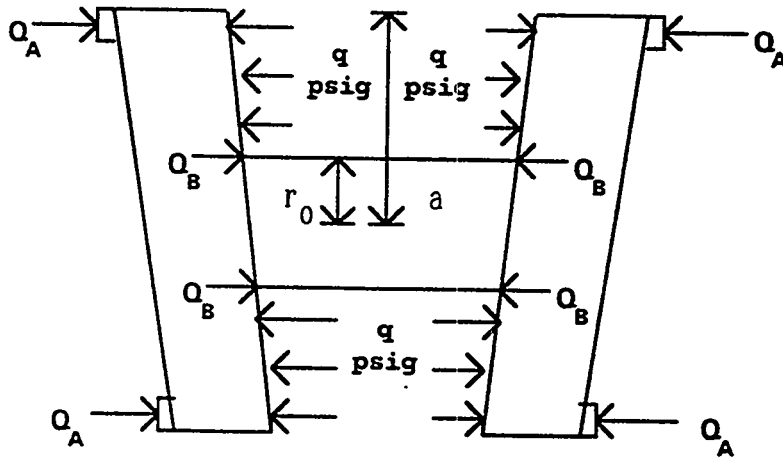

4.2 The external pressures, on the high pressure side and on the low pressure side, will be analyzed using Ref. 2.1 Table 24 Case 2d and Case 1b in combination. Case 2d will be used to determine the force exerted on the disc hub perimeter and on the disc perimeter at the seat ring. Based on the configuration of the pressures, the force on the seat ring will be in the opposite direction as the force obtained for the internal pressure load. Since the pressure on the high pressure side of the disc is higher than the pressure on the low pressure side of the disc, the differential force Q_b at the perimeter of the disc hub will be used in the Case 1b analysis to determine the additional force on the seat ring on the low pressure side disc. Case 1b is considered to be appropriate since the disc hub will provide a rigid "guided" type of configuration in the center of the disc.

Force on the perimeter of the disc hub (Q_b) (Case 2d)

$$Q_b = qa \frac{C_2 L_{17} - C_8 L_{11}}{C_2 C_9 - C_3 C_8}$$

where the equations for the C and L variables are given on the prior page.

Force on the perimeter of the disc (Q_a) at the seat ring (Case 2d)

$$Q_a = Q_b \frac{b}{a} - \frac{q}{2a} (a^2 - r_o^2)$$

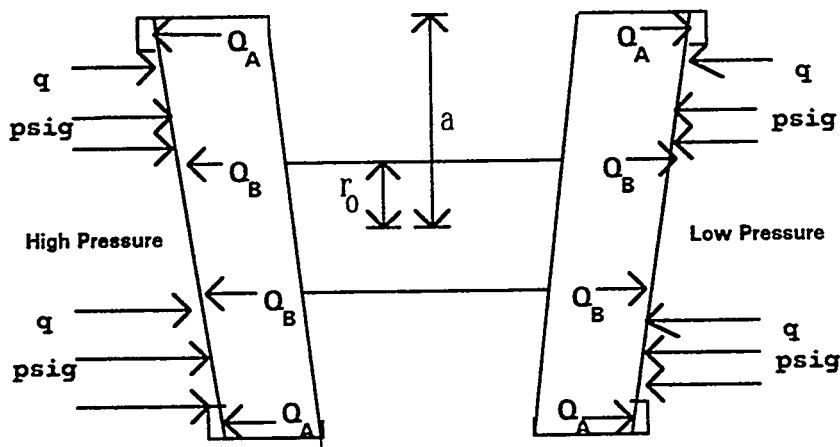

- 4.3 The differential Q_b (accounting for the high pressure side pressure being higher than the low pressure side pressure) will be increased to account for the differential pressure on the hub area that was left out of the Case 2d equations. The differential Q_b and the differential hub pressure will be combined and used as W in the Case 1b equation.

$$W = Q_b + \frac{q\pi b^2}{2\pi b}$$

Force on the perimeter of the disc (Q_a) at the seat ring on the opposite disc from the pressure (Case 1b)

$$Q_a = -W \frac{r_o}{a}$$

Where: $a = \frac{1}{2}$ Valve disc sealing diameter (Mean seat diameter)
 $b =$ Valve hub radius
 $r_o = b$
 $q =$ pressure over hub area

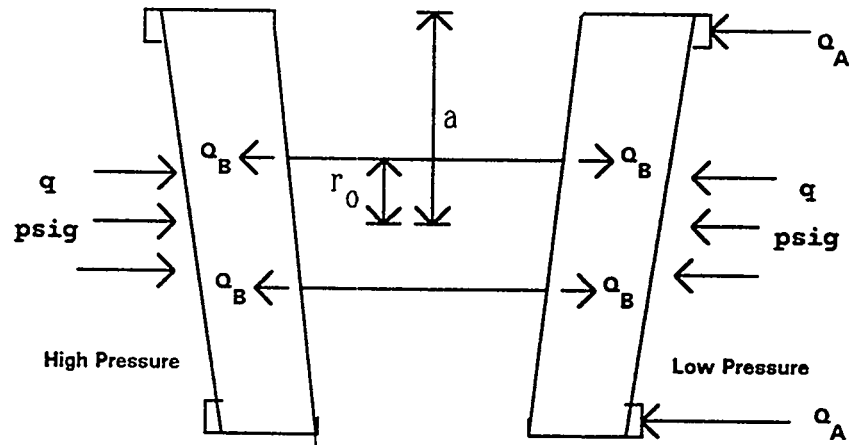

4.4 The force on each seat ring due to the four pressure loading conditions will be added together and multiplied by the seat ring perimeter to determine the total force.

1. Force on the seat ring on the high pressure side of the valve will be:

Force due to internal pressure - Force due to high pressure side (lb/in)

2. Force on the seat ring on the low pressure side of the valve will be:

Force due to the internal pressure - Force due to the low pressure side
+ Force due to the differential pressure between the low pressure side
and the high pressure side (lb/in)

4.5 The relationship between the Valve Disc Factor and coefficient of friction, μ , will be determined using Ref. 2.2 Equation 2.1a.

$$DiscFactor = \frac{\mu}{\cos \theta - \mu \sin \theta}$$

Where: μ = coefficient of friction
 θ = seat angle, °

4.6 Total Required Thrust to open the valve will be the addition of the two forces determined at the seat rings above times the Valve Disc Factor plus the Unwedging Thrust.

5.0 CONCLUSIONS

The Total Required Thrust for opening any valve, under stated pressure locking conditions, is dependent on the final wedging force from the previous closing cycle. For a given torque switch setting, the wedging force from valve closure can vary because the inertia overshoot is affected by the magnitude of the differential pressure across the disc. Typically, the highest wedging force would be introduced when the valve is closed without differential pressure. This calculation conservatively quantifies the unwedging force based upon calculated closing thrusts or actual as-tested data with static test conditions. Regardless of the approach used, the dependence of the opening thrust during unwedging on the wedging force from the previous closing cycle must be quantified to ensure proper operation of the valve. Furthermore, the unwedging force is affected by the pressure loading of the valve discs. As the differential pressure across a disc decreases so does the unwedging force. Full flow testing has indicated the unwedging component becomes essentially zero and only the pressure loading component contributes to the Total Required Thrust.

WYLE CONSULTING ENGINEERS
LABORATORIES GROUP
BIRMINGHAM, AL

**FLOW LOOP DIFFERENTIAL PRESSURE
AND PRESSURE LOCK TESTS
ON A
14-INCH WILLIAM POWELL GATE VALVE
FOR
ENERGY OPERATIONS, INC.
GRAND GULF NUCLEAR STATION**

test PROCEDURE

Test Purposes:

- 1. Pressure Lock Testing to Confirm Calculations**
- 2. Flow Testing for Untestable Low Pressure Injection Valves to Confirm Specified Required Thrust Adequate**

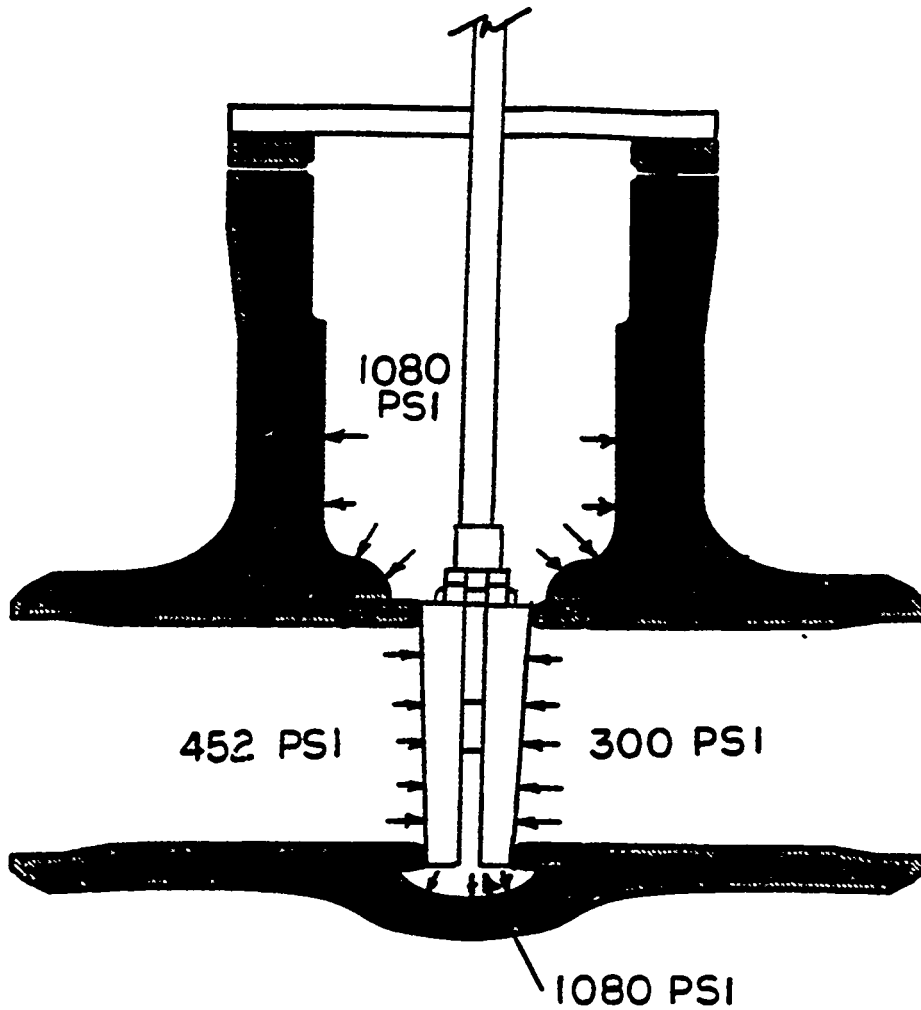

Pressure Lock Test
Conditions

Pressure Lock Test Results

Pre-Test LLRT showed 0 leakage
(Worst Case for Pressure Lock)

Measured vs Calculated Unwedging Thrust

Smart Stem - Wyle Labs

Measured Closing Thrust	Measured Unwedging Thrust	Calculated Unwedging Thrust
90,309 #	55,146 #	57,894 #

Actual

Total Opening Thrust Measured
by Wyle Labs
87,000

Theoretical

Total Open Thrust Calculated
by GGNS
 $31,926 + 57,894 = 89,820$

Difference = 3%

mgp11

TEST COMPLETE
6.3.3 PRESSURE LOCK TEST TEST#5 a (TORQUE SWITCH SET TO APROX. 1.75)

THR1 LB STEM THRUST

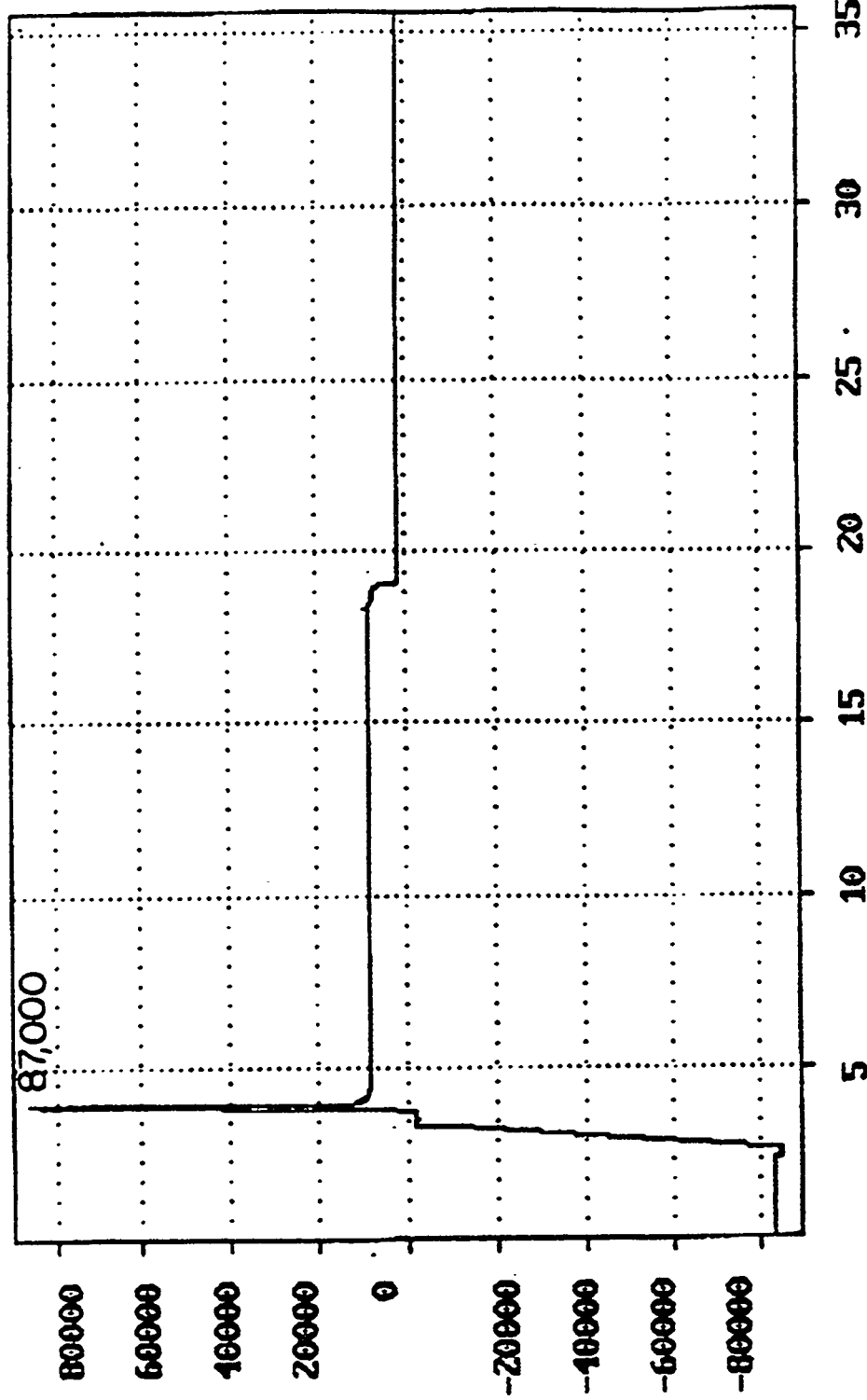

time
B430081 DataSet 009 Duration 00:00:35:545 Recorded On 12/29/92 11:24:50

**International Experience
Nabil Schauki, Siemens Power Corporation**

Chattanooga, TN

(Enclosure 6)

PUBLIC WORKSHOP

PRESSURE LOCKING AND THERMAL BINDING OF GATE VALVES

INTERNATIONAL EXPERIENCE

**Nabil Schauki, Ph.D., Siemens Power Corporation, 5959 Shallowford Road,
Suite 531, Chattanooga, Tennessee 37421**

1. Introduction and History

Pressure build-up beyond design conditions by heating up entrapped cold water is truly one of the phenomena which can be observed internationally. Water entrapment is not limited to water systems and can occur by condensate accumulation or during hydro-testing. This has already been observed in German fossil power plants.

The greatest concern was more focused on the integrity of the components. Therefore, pressure relief requirements were issued in technical standards whenever the susceptible system improves its leak tightness by pressure difference increase, such as pressure sealed bonnets.

For a better understanding and verification of pressure build-up calculations, tests were performed. Figure 1 shows a sketch of such a test on a gate valve with entrapped cold water. The tested valve was an 8" gate valve with a design pressure comparable to the U.S. 600# pressure class. The tests started at room temperature (about 63°F). After a moderate increase, the measured bonnet pressure increased rapidly with increasing temperature to about 1,000 psi at 100°F and 2,000 psi at 120°F (see Fig. 2), which correspond to theoretical calculations of pressure gradients of heated entrapped water.

**Public Workshop
Pressure Locking and Thermal Binding of Gate Valves
International Experience**

2. Solutions and Their Application Limits for Gate Valves

The classical simple solutions which are commonly used in nuclear power plants in the U.S. were also used in Germany. The simplest way is to vent the bonnet via a hole in the disk. This solution is acceptable in case the leak tightness is required in one flow direction. Problems would arise in the case of leak tightness requirement for both flow directions. Furthermore, the possibility of turning the disk with the vented side in the wrong direction is given during reassembly of the disk after maintenance work. Such problems can be avoided by placing the venting hole in the seat ring (see Fig. 3).

Other venting methods include the application of a venting bypass (see Fig. 4) or the use of a pressure relief valve or rupture disk as shown in Fig. 5. The relief valve solution has been applied in new NPPs in favor of the rupture disk because the relief valves close at their blowdown pressure. Such solutions require measures for hydro-testing, such as isolation valves for the "bypass" or disassembly of the relief valve and application of a blind plug.

A solution for parallel disk valves with a high susceptibility for functional problems was found by applying a disk holder, allowing the parallel disks to float and seat downstream of the high pressure side (see Fig. 6). The limits of this solution are exemplified by the requirement of leak tightness at low pressure differences.

The system requirements and interaction between the pressure relief control and system must be carefully considered to identify the correct application and avoid creating new problems. For example, the size of the pipe connection of the relief valve to the bonnet is dictated by the seismic loads and not the internal pressure.

**Public Workshop
Pressure Locking and Thermal Binding of Gate Valves
International Experience**

Figure 7 shows a sketch from the early seventies discussing the different solutions for a German NPP.

3. Pressure Build-Up in Closed System Sections

Other problems were encountered in the early eighties in which entrapped water in a piping section between two valves was heated up as shown in Figure 8. Valves which usually have difficulty in maintaining leak tightness, such as a check valve, did not vent as the pressure increased due to heat-up. This can lead to a problem if the heated part of the pipe section is more than 10% of the closed section (see Fig. 9). In most cases, it could be shown that the installed valves were capable of venting the pipe system. For example, the stem was lifted by the pressure in designs which have spring-supported stem nuts. The vent pressure was precalculated and verified by testing.

SIEMENS

SPC

PUBLIC WORKSHOP MEETING

February 4, 1994

**PRESSURE LOCKING AND THERMAL BINDING
OF GATE VALVES**

Dr. Nabil Schauki

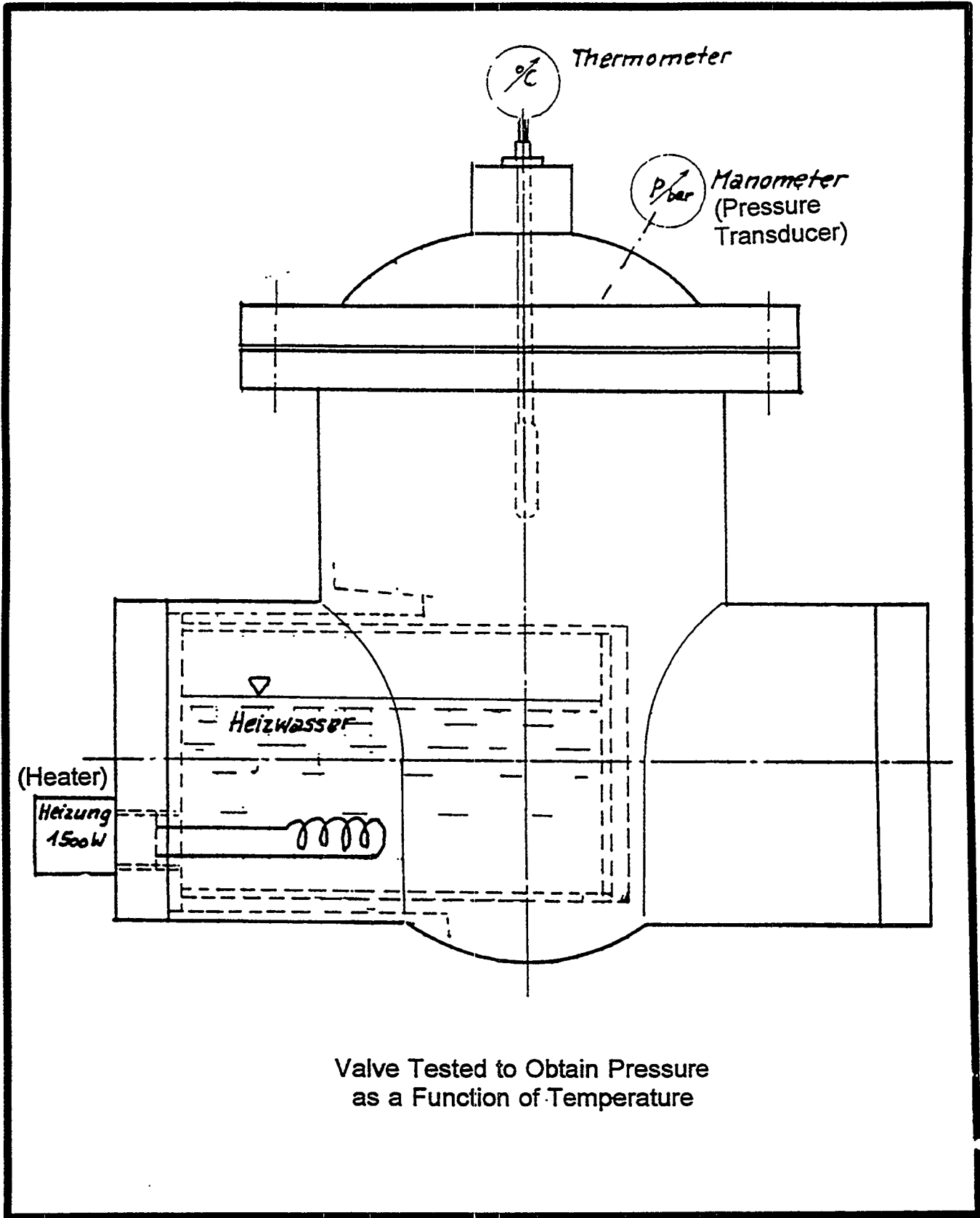

Valve Tested to Obtain Pressure
as a Function of Temperature

N. Scheid

8" 600# GATE VALVE

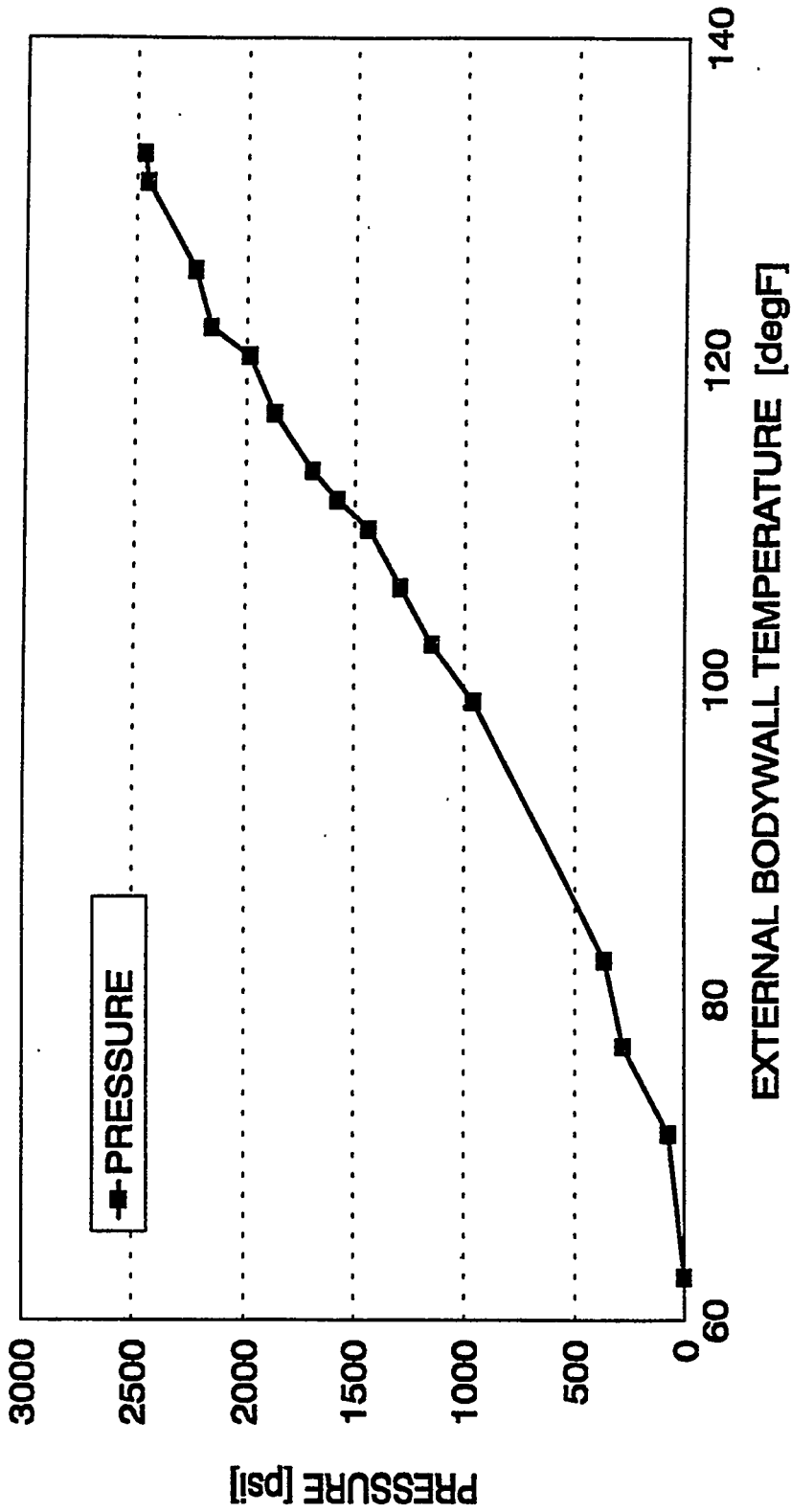

MEASURED BONNET PRESSURE AS A FUNCTION OF EXTERNAL BODYWALL TEMPERATURE

lgc:\windows\designer\013094

N. Schauf/01-18-94

Pressure Locking Control

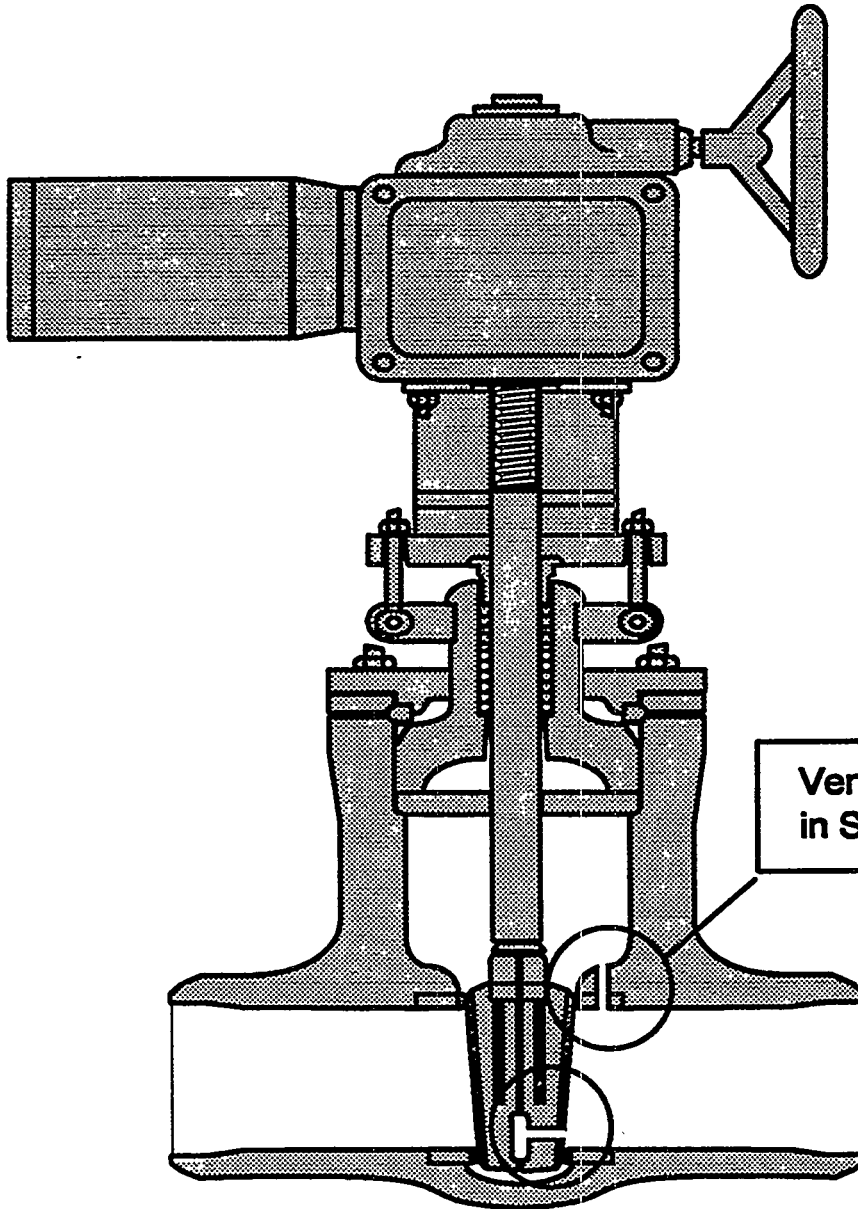

Venting Via Hole
in Seating or Disk

Bonnet Pressure Control by Means of Internal Venting

Modified Valves

EPN	Change	Initiater	Doc.Number	Date
1E12-F003A	close on limits 95%	DVR 1-1-83-342&387	M01-1-86-005 TSC1-708-83	5\30\88
1E12-F003B	close on limits 95%	DVR 1-1-83-342&387	M01-1-86-005 TSC1-708-83	5\30\88
2E12-F003A	close on limits 95%	DVR 1-1-83-342&387	M01-2-88-018 TSC2-756-86	1\6\89
2E12-F003B	close on limits 95%	DVR 1-1-83-342&387	M01-2-88-018 TSC2-756-86	1\6\89
1E12-F004A	Bonnet Vent &Proc. Rev.	DVR 1-2-89-0047	P01-1-90-036	1\13\92
1E12-F004B	Bonnet Vent &Proc. Rev.	DVR 1-2-89-0047	P01-1-90-029	12\31\91
2E12-F004A	Bonnet Vent &Proc. Rev.	DVR 1-2-89-0047	P01-2-90-035	3\19\92
2E12-F004B	Bonnet Vent &Proc. Rev.	DVR 1-2-89-0047	P01-2-90-030	3\24\92
1E12-F009	Larger Motor Op & Proc. Rev.	GL 89-10 & LLRT concern Vlv. Bind	M01-1-87-044	9\23\87
2E12-F009	Larger Motor Op & Proc. Rev.	GL 89-10 & LLRT concern Vlv. Bind	M01-2-88-007	1\26\89
1G33-F001	Flex wedge to Dbl.Disc	GL 89-10 & LLRT concern	P01-1-91-516	12\11\92

Pressure Locking Control

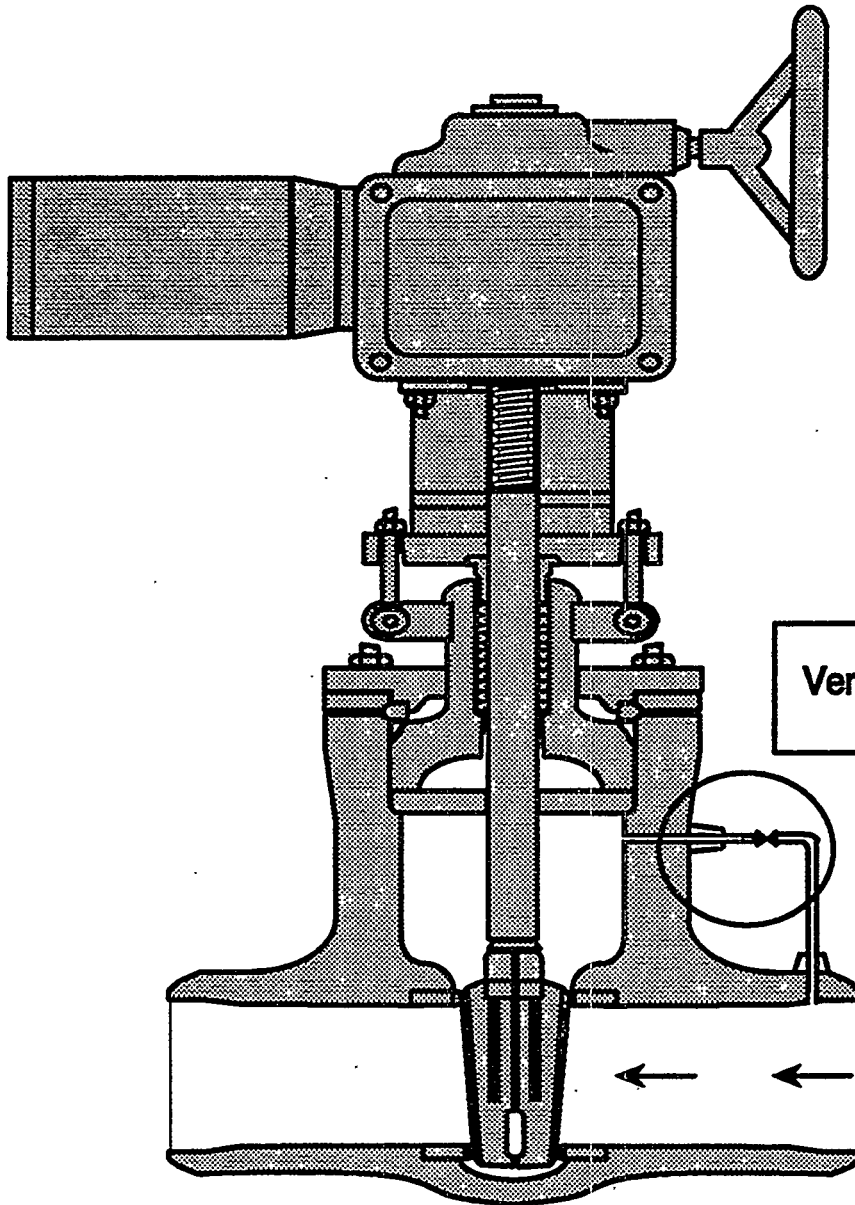

Venting Via Bypass

Bonnet Pressure Control by Means of Bypass to System
Hydrotest Direction to Be Considered

Pressure Locking Control

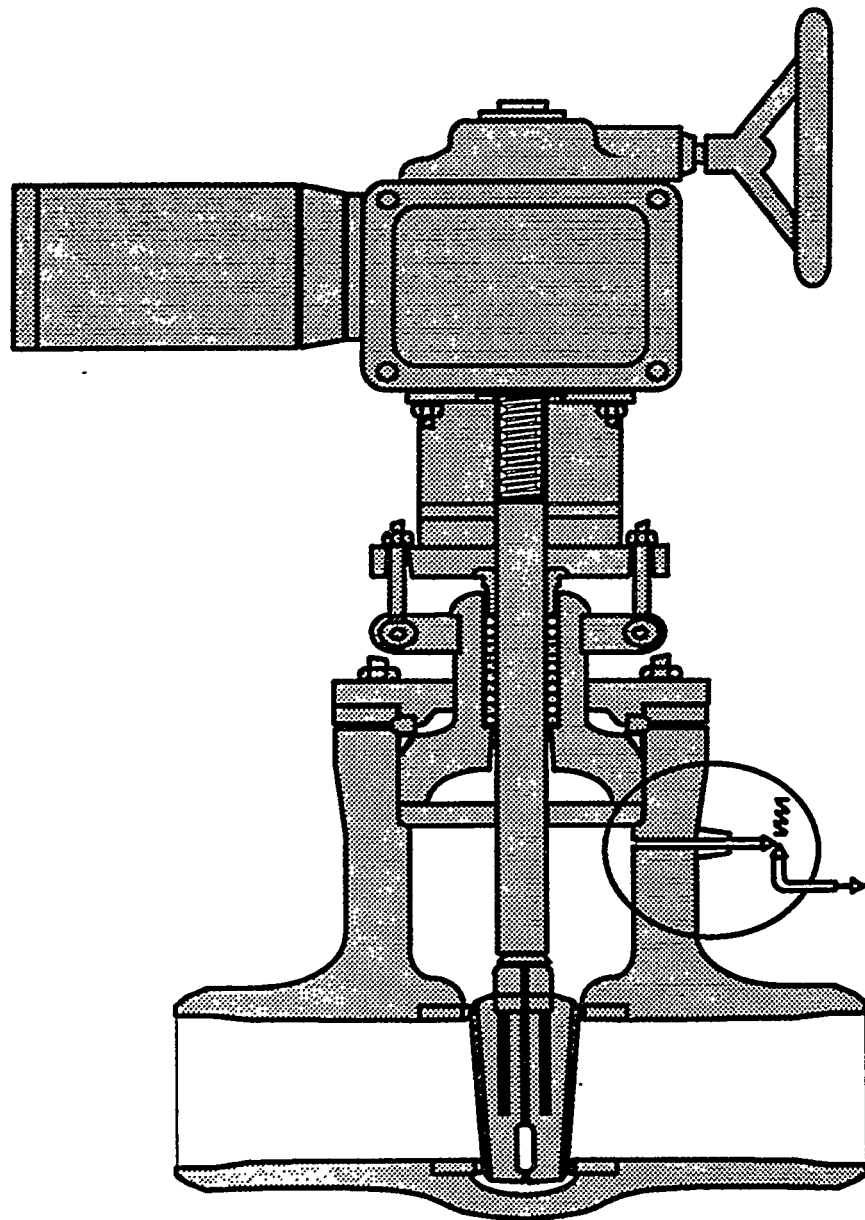

Venting Via Relief
Valve or Rupture
Disk

Bonnet Pressure Control by Means of Internal Venting

Pressure Locking Control

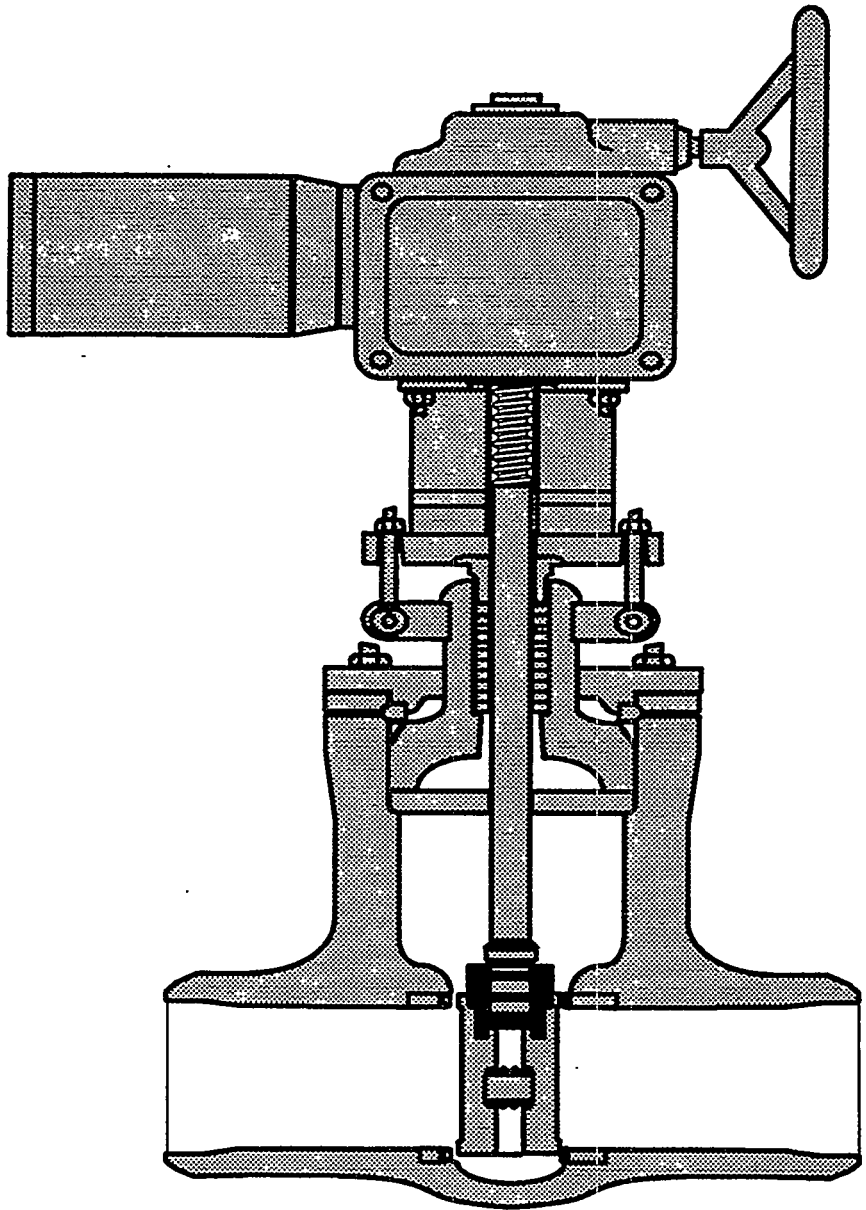

Bonnet Pressure Control by Means of Design Features (Disk Holder)

SIEMENS

ernkraftwerk

Überdrucksicherung in Schiebergehäusen
mit selbstdichtendem Deckelverschluss

V 632-RA Mock
Rev. o 4.6.74

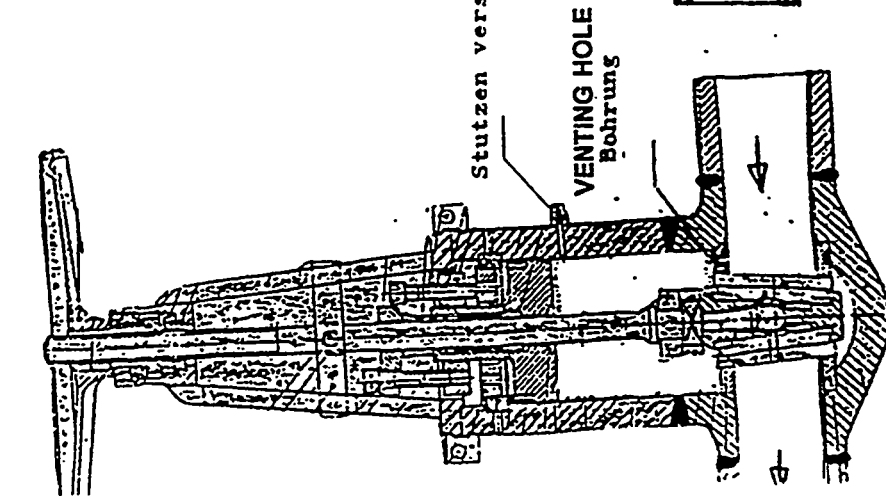

Ausführung 1
Eintritt/Austritt gebohrt

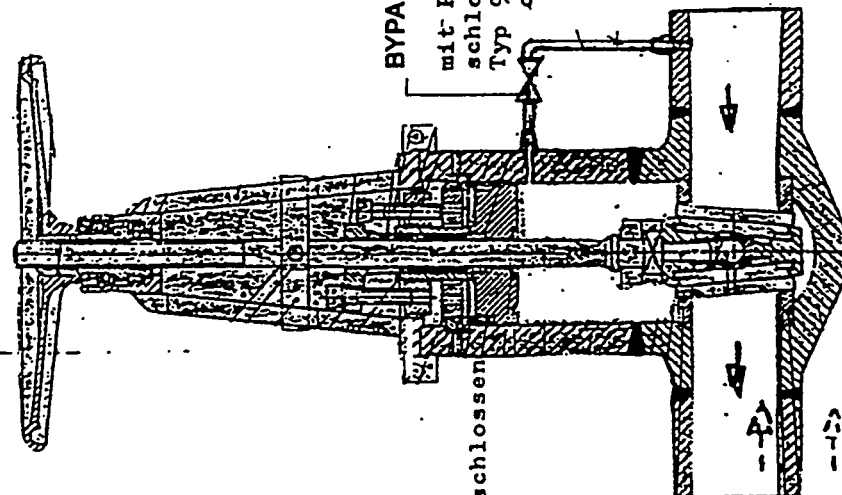

Druckprobe

Ausführung 2
an Eintritt/Austritt umführt
Abspermmöglichkeit für Druck-
proben erforderlich!

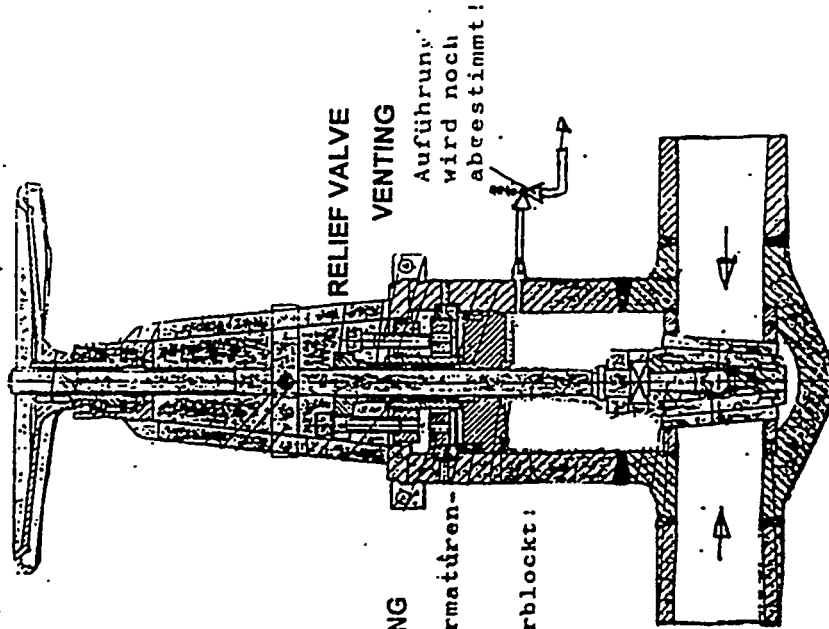

Ausführung 3
mit externer Entlastung,
erforderlich bei beidseitiger
Durchströmung

W. Orpld

Globe MOVs in Series

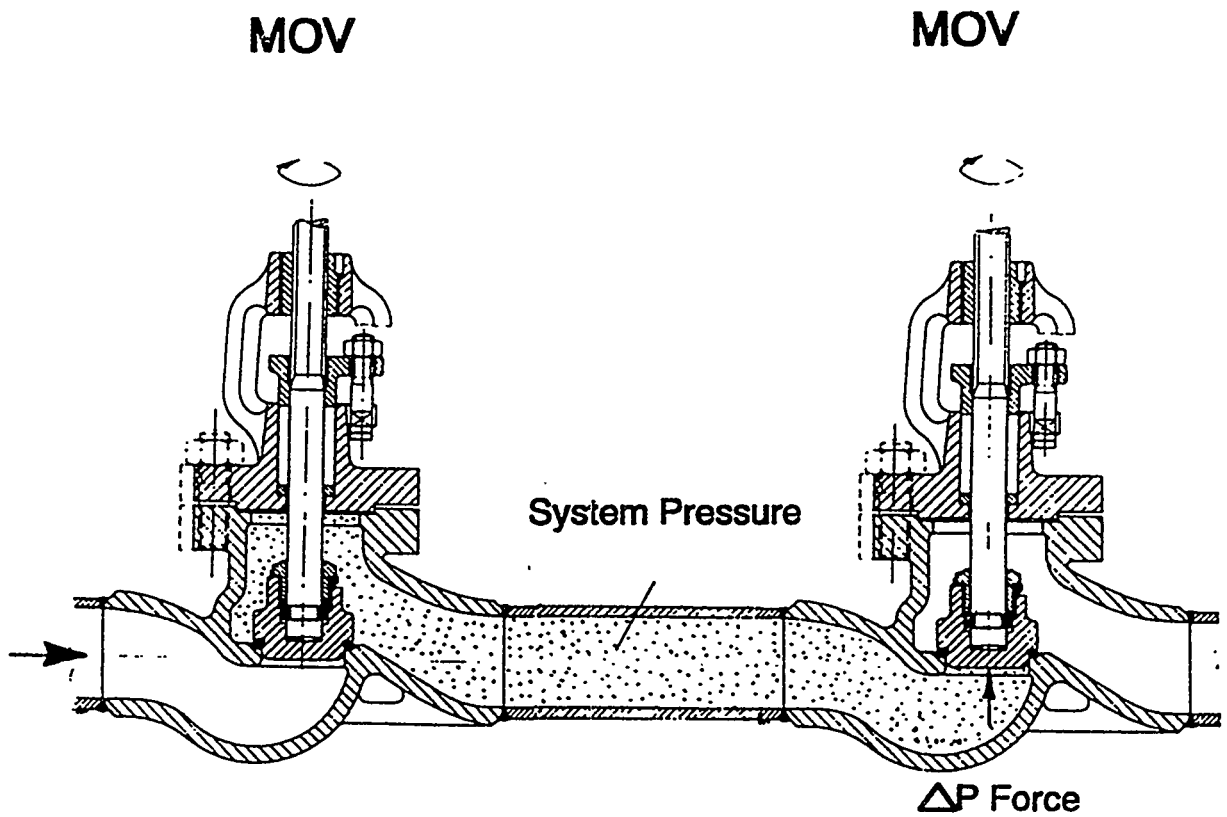

**Relief of Pressure Build-Up in System
Due to Heat-Up of Enclosed Cold Water
(LOCA)**

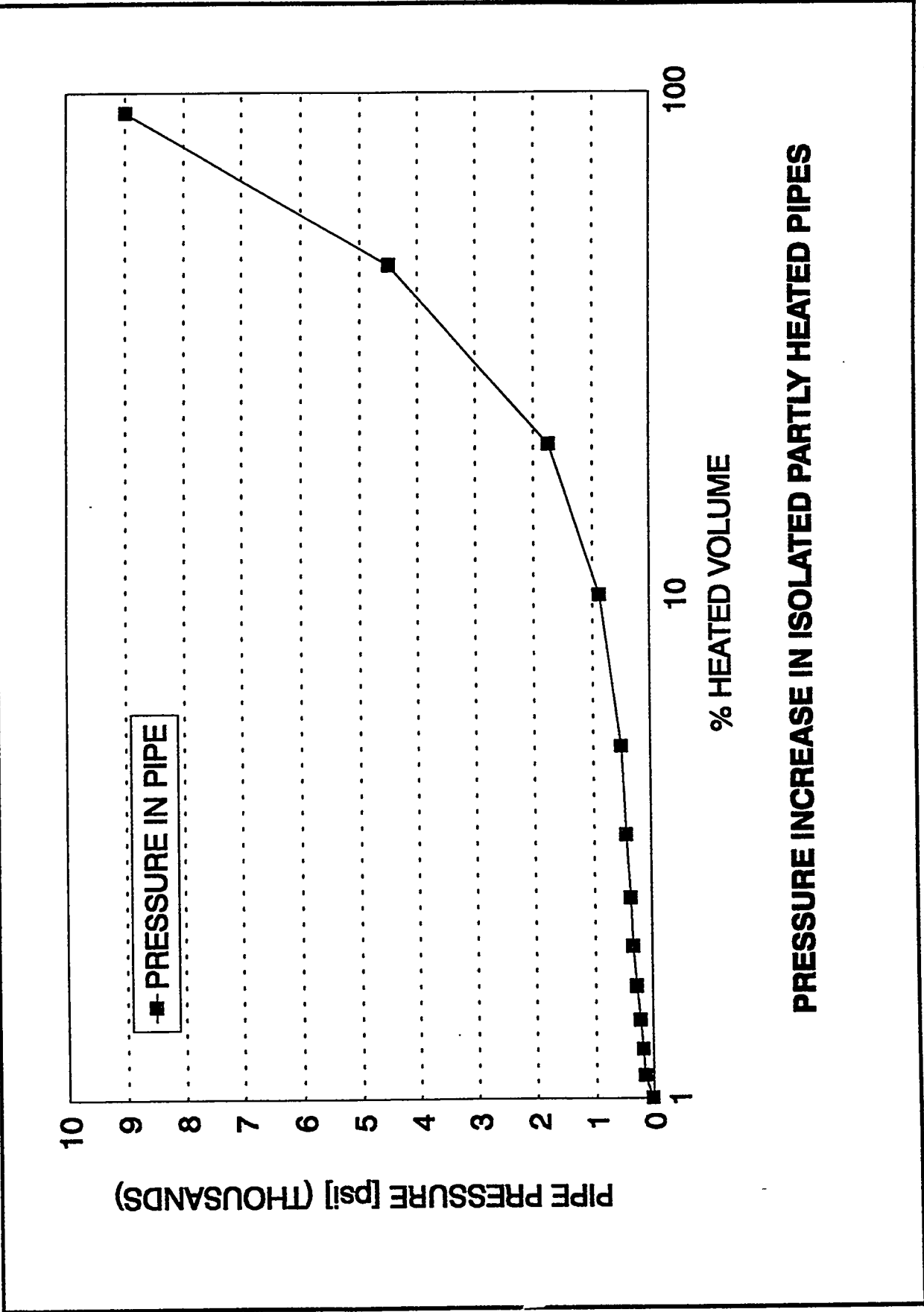

**Licensee Experience
Mark Dowd, LaSalle County Station**

**Lead Mechanical Engineer
LaSalle County Station
Marseilles, IL**

(Enclosure 7)

GATE VALVE LOCKING EXPERIENCE AT LASALLE COUNTY STATION

By

Mark Dowd
Lead Mechanical Engineer
LaSalle County Station

INTRODUCTION

I begin my presentation by cautioning everyone that valve locking events have occurred and that we must not sanitize our evaluation of the significance of an event by relying on the statistics of probability to core damage. Based on my operational background, I emphasize the need to limit the number of possible failures that would require operator response. The breadth of issues addressed in this presentation is shown in the enclosure labeled AGENDA.

The reactor core isolation cooling valve, 1E51-F063, failure to open event is discussed in the enclosure labeled EXECUTIVE SUMMARY. This event was a surprise to the station and caused us to review our actions to resolve gate valve locking events. The staff efforts discussing the failure mechanics for hydraulic locking and thermal binding are described in subsequent enclosures. This includes a new failure mechanism involving thermal binding as the result of the differential temperature across a disc and thus suggests a need to look for multiple failure mechanisms.

EVALUATIONS

The overview of our approach is contained in the enclosure labeled THERMAL BINDING/HYDRAULIC LOCKING OF GATE VALVES. We reviewed specific valve events at LaSalle Station in addition to certain valves identified as susceptible by GE SIL 368 Revision 1 issued in 1989. These events and valves are discussed in the enclosure labeled Attachment A.

The initial task was to develop a screening process with appropriate criteria that would provide guidelines for consistent evaluation to determine the susceptibility of each valve. These criteria are in the enclosure labeled Attachment B. The process includes criteria for qualifications of the personnel conducting the screening. Individual valve evaluation involves use of a procedure to assess specific aspects about function, conditions, and when operation is needed. Illustrative examples in which the procedure is applied to three separate valves are shown in the enclosure labeled Attachment C. A list of valves at LaSalle Station susceptible to thermal binding and pressure locking is provided in the enclosure labeled Attachment D.

The enclosure labeled Attachment E provides support information about certain valves. This includes information such as local temperature conditions, valves grouped by PRA priorities, and graphs illustrating the valve bonnet pressure response to ambient temperature increases.

One example showed that a 64 °F rise in temperature could threaten the valve integrity within 1 hour. A conceptual design using a surge volume to prevent hydraulic locking was presented.

The issue involving thermal binding as a result of the differential temperature across the disc is covered in the enclosure labeled Potential Binding of 2E12-004B (RHR Valve). This analysis was conducted with an 80 °F temperature differential (160 °F to 80 °F). The valve body seat rings and disc displacements were assessed with a two dimensional finite element model. The results indicate thermal binding could be experienced.

AGENDA
GATE VALVE LOCKING MEETING

1. 1E51-F063 valve event and our response.
2. Industry Response since 1977.
3. Failure Mechanics overview:
 - a. Classical Thermal Binding.
 - b. Differential Temperature Thermal Binding.
 - c. Reactor Pressure Leak Back with subsequent Pressure Blowdown Hydraulic Lock.
 - d. Thermal Fluid Expansion Hydraulic Lock.
 - e. Multiple Failure Mechanisms.
4. Overview of LaSalle SEC's screening criteria and results of screening.
 - a. Qualifications of Screening Personnel.
 - b. Screening Questions.
 - c. Steam Valve Screening.
 - d. Differential Temperature Screening.
 - e. Results of Screening.
5. Review Possible Solutions for Hydraulic Locking.
 - a. Calculate Maximum pull out force and determine adequacy of motor operator and valve to open.
 - b. Modify bonnet or valve disc. to provide a vent path.
 - c. Modify bonnet to provide a surge volume.
 - d. Prevent full closure of the valve.
 - e. Modify Motor Operator and/or valve to open against Maximum calculated pull out force.
 - f. Further analyze valve functions , response times , probable environmental conditions and accessibility for possible exclusion from list of susceptible valves.

6. Review Possible Solutions for Thermal Binding.
 - a. Calculate Maximum pull out force and determine adequacy of motor operator and valve to open.
 - b. Prevent full closure of the valve.
 - c. Modify Motor Operator and/or valve to open against Maximum calculated pull out force.
 - d. Further analyze valve functions , response times , probable environmental conditions and accessibility for possible exclusion from list of susceptible valves.
7. Prioritize susceptible valves.
8. Determine most cost effective method to address susceptible valves.
9. Determine tentative schedule to address susceptible valves.



EXECUTIVE SUMMARY

Root
Cause
Analysis

1. Nuclear Unit 2. Event Date 3. Report No. 4. Evaluator

Plant	Unit	Time	Month	Day	Year		Jeff Miller C. Snyder M. Vrla M. Wendling M. Wielgopalan
LaSalle	1		Feb	10	93	373-180- 93-00150	
			Feb	26	93	PIF	

EVENT DESCRIPTION

Unit 1 was shutdown twice for identical problems in the RCIC F063 valve. During the L1R05 outage, the RCIC F063 valve was replaced from a flex-wedge gate valve to a parallel double disk gate valve. The double disc gate valve design is susceptible to pressure binding. This condition is the result of trapped fluid in the bonnet cavity becoming pressurized due to an increase in the fluid's temperature. The bonnet pressure and resultant force with which the valve's discs are seated became so great that the valve operator could not overcome these forces to open the valve. This resulted in the valve being declared inoperable and required shutdown of the unit.

EVENT NARRATIVE

In 1989, Generic Letter 89-10 addressed concerns about the adequacy of certain safety-related, motor-operated valves. GL 89-10, Supplement 3, addressed specific concerns regarding "blowdown" valves, i.e. those valves in high energy lines that are required to close to isolate a line break. The RCIC steam line is one of those lines. The specific concern is the capability of the valve to isolate, i.e. to actually close when subjected to blowdown flow. For the RCIC F063 valve, the design conditions involve steam flow at 575 degrees Fahrenheit and 1250 psig. Modification packages M01-1-91-002B and P01-1-91-509 were created to upgrade the operator and the valve to improve the margin to adequate blowdown performance.

During the L1R05 outage, the 1E51-F063 valve and actuator were replaced by a heftier version. Testing and several inspections were performed to verify proper installation of the valve. During this time, it is believed that the set screws on the torque switch were inadvertently left loose.

On February 10, as required for pre-planned maintenance on other unrelated instrumentation, the 1E51-F063 valve was closed and remained closed for approximately 10 hours. During this time no abnormal indications were noted.

Upon completion of RCIC system maintenance, the 1E51-F076 (RCIC Steam line warm-up valve) was opened to equalize pressure and temperature around the 1E51-F063 after which an attempt was made to open the 1E51-F063 from the control room. Dual indication was received, followed by a thermal overload trip approximately 6 seconds later. The overload was reset and another attempt was made to open the valve, resulting in a second thermal overload trip. The thermal overload was again reset, and an ammeter/chart recorder was installed on the power leads. The valve was then given a close signal. Motor current was observed to be in excess of 100 amps for 1-2 seconds, at which time the circuit breaker was tripped manually.

Unit 1 was brought to Cold Shutdown to initiate repairs on the RCIC Steam Line Inboard Isolation Valve (1E51-F063). During the shutdown, a Generating Station Emergency Plan (GSEP) Unusual Event condition was entered on 02/13/93 at 2000 hours due to the plant shutdown required by Technical Specifications. The GSEP was terminated at 1800 hours on 02/14/93 when the RCIC system was no longer required for Unit 1 operating conditions.

Containment entry was made during unit shutdown at approximately 400 psi Reactor pressure to perform a preliminary inspection of the valve/actuator for signs of external damage. No visible damage was noted. The local indicator for the Limitorque operator spring compensator pack (SB design) indicated the spring compensator was fully compressed. The local position indicator (MDPI) showed the position of the valve to be 10-12% open in the as found condition although it was later determined to be fully closed. The limit switch housing cover was removed to perform an inspection of the torque switch and limit switches. The torque switch was found to be over-rotated, and the close setting indicator and set screws had slid underneath the torque limiter plate, effectively raising the close torque switch setting. The torque switch setting screws on the open and close side were found to be loose. Based on no apparent damage to the limit switches and torque switch, the valve actuator was declutched and the valve was manually cycled to try to determine if the valve was internally bound. The valve was easily cycled using the handwheel with no evidence of binding in the valve or actuator. When manually cycling the valve, the local position indicator had been determined to be shifted. The local position indicator would display a valve position greater than 100% when the valve was full open and indicated approximately 20% open when the valve was full closed.

To continue analyzing the valve condition, the torque switch setting screws were adjusted to a setting of 1.00/1.00 (open/close) and the valve was electrically cycled to the open position. When the valve was cycled to the full open position it was found to be stopping about 2-3 inches from the valve backseat. The limit switch adjustment was checked and the limits were found to be out of adjustment by approximately 20%, this corresponds to the offset that was observed in the local position indicator when the valve was full closed.

The limit switches were properly adjusted and the valve was electrically cycled three times with the torque switch adjusted to a setting of 1.00/1.00 (open/close) while the valve was monitored by VOTES (VALVE OPERATION TEST and EVALUATION SYSTEM) diagnostic equipment. No abnormalities were noted in the VOTES traces. The torque switch setting was raised to 1.50/1.50 and the valve was again cycled three times with the valve monitored by VOTES equipment. No abnormalities were noted with the VOTES traces and the thrust characteristics were consistent with the previous (prior to failure) VOTES test results.

The compensator spring assembly and stem nut were removed with the actuator in place. They were inspected for evidence of abnormal wear or indications which might explain the shift in limit switch settings. No wear was noted and adequate spline engagement between the stem nut and drive sleeve was observed.

The actuator was removed from the valve and brought to the MM (Mechanical Maintenance) shop for disassembly and inspection. No damage was noted with the actuator internals. The electrical components were inspected (cartridge assembly, limit switch assembly and the torque switch). The results of this inspection were 1) the torque switch setting screws being loose, 2) the close torque switch setting block being underneath the torque switch limiter plate, and 3) the torque switch limiter plate being slightly bent (pushed away from the torque switch face) on the close setting side, and 4) the torque switch limiter plate being installed between two flat washers on the torque switch shaft.

The valve internals were inspected. There were no obvious gouges in the valve body, sides and/or seat areas. A NDE (Non Destructive Examination) PT (DYE PENETRANT) exam of the valve seating surfaces was performed and a radial indication was found on the upstream seating surface. This was evaluated by engineering and found to be acceptable.

The valve disc pack and stem were also inspected. The disc retainer pin (wedge pin) was found to be sheared with the lower disc retainer found inside the valve bonnet. Apparently, the rotation of the valve stem within the upper wedge sheared the pin. A gap of approximately 1/8 to 3/16 inch was visible between the top of the upper wedge and the bottom of the shouldered portion of the stem. No additional damage or abnormal wear was noted.

The valve stem, disc assembly and the Limitorque actuator were completely replaced. The re-assembled valve was post maintenance tested, i.e. electrical motor tests (Megger and Winding Resistance readings), VOTES test, limit switch settings verified, in-service leakage test and seat leakage test. All results were satisfactory.

A Root Cause Analysis team was assembled to determine the cause of the valve failure. Many different possible scenarios were examined. Based on the as found condition of the valve and the most probable failure possibilities, the following sequence of events was developed.

The torque switch setting set screws were found to be loose. There was no apparent scarring of the jagged edge on the underside of the torque limiter switch that hold the switch setting block in place. If scarring was present, that would have suggested a great amount of force to rotate the torque switch setting block and screw from a locked position to under the limiter plate. This suggested that the screws were somehow loosened. It has never been identified in LaSalle's history with MOV's that this particular screw would become loose as a result of normal valve operation. The individuals that adjusted the torque switch setting believed that they had tightened the screws. The individuals that replaced the limiter plate and performed the different testing and inspections did not observe that the screws were loose. It can only be assumed that: 1) the screws were not tightened as tight as they should have been originally, or; 2) someone for another reason loosened the screws and failed to tighten them down. The loose screws would have only resulted in the torque switch setting increasing to a setting of 2 (two). In order for the torque switch setting block and screw to slide under the limiter plate, the plate must have been abnormally oriented.

When the limiter plate was installed, it was installed with a washer above and below the plate, raising the height of the plate relative to the setting block. This is not common practice, although there was no specific guidance regarding the use of the spacer washers. It is believed that this extra space and a slight bend upward of the plate may have been enough to allow the switch setting block and set screw to slide under the plate. Without the extra space under the plate, the switch setting block would have contacted the plate squarely and not been allowed to slide underneath to the higher torque settings.

With the combination of the loose switch setting block screws and the limit plate raised and slightly bent, the trip torque value was allowed to increase. The valve was cycled at least 11 times prior to the failure. It is believed that with each cycle, the setting increased slightly, resulting in the as found setting of 4.0. (The original torque switch setting was a little less than 2.0.)

The increased torque forced the stem nut when the valve was fully closed to "walk" up the stem and fully compress the Limitorque actuator spring compensator. At this time the limit switch settings were apparently not affected as the valve did not trip the thermal overload. This indicated that the actuator stopped on torque when the torque switch opened.

Apparently, when the valve was being given an open signal, the valve stem retainer pin sheared. This is indicated by the stem unthreading from the disc upper wedge approximately 5/32" corresponding to approximately 1 7/8" rotation of the stem. Each rotation of the stem resulted in one rotation of the Limitorque drive sleeve. This would cause the valve position limit switch and local position indicator to be offset by the amount of the drive sleeve rotation with no actual movement of the valve disc assembly. This evolution apparently occurred during the two attempts to open the valve which resulted in the thermal overload trips that were discussed previously.

When the valve was given a close signal, the motor current was monitored by a signature trace device. The motor current trace indicated a locked rotor condition. This was due to the valve already being fully closed and unable to move any farther. The torque switch would have opened to stop the motor on high torque, but it was bypassed because of the valve position limit switch offset. This closing attempt was terminated by the breaker being opened when it was noted that the valve motor was exhibiting a locked rotor condition based on current reading.

With the root cause of the valve failure believed to be identified, Unit 1 startup began on February 19.

On February 26th, the 1E51-F063 valve was to be cycled under similar conditions as on February 10th to verify proper operation of the valve. This was part of the corrective action from the Root Cause Analysis. The valve was closed and then followed by a period to cool the valve. The 1E51-F076 was opened to equalize pressure and temperature across the 1E51-F063 valve. An attempt to open the 1E51-F063 valve was made. The valve failed to open. The valve was left as is (no attempt to close the valve), and the valve was declared inoperable. A detailed test plan was developed (LST 93-029), which included specific data collection steps, including repetition of the failure conditions with the unit operating at a very low power level and drywell accessible.

Once a drywell entry was possible, individuals inspected the valve. They found the valve closed and the limit switch misadjusted. They manually cycled the valve. They found the valve would open and close normally. They also determined that the valve stem had partially rotated out of the upper wedge. They then returned the valve to the fully closed position.

In accordance with the test plan, the failure conditions were re-established, including the previously observed warming times with the warming valve (1E51-F076) open. Individuals then entered the drywell to manually open the 1E51-F063 valve. The valve could not be manually opened. A small trickle of water was noticed leaking from the valve packing. The valve packing gland nuts were loosened, and it was observed that the packing gland follower moved. From these observations, it was determined that the valve internals were experiencing bonnet pressure locking.

The valve and operator were inspected further. The wedge pin had once again been sheared. The torque switch was undamaged, and the set screws were found tight. The valve was repaired and modified to prevent pressure locking.

Unit 1 was then started up, followed by testing of 1E51-F063 which performed satisfactorily.

INAPPROPRIATE ACTIONS

1. The Modification Process did not identify that the valve could pressure lock during certain operating sequences.

The possibility of the valve binding due to a differential pressure between the valve bonnet cavity and the connecting piping was never considered. The RCIC system utilizes steam from the reactor vessel to operate. This type of valve binding is generally associated with liquid systems and was, therefore, never considered by the modification engineer. The modification review process requires a search through an industry-wide computerized database. This search failed to flag any of the several key industry documents which discuss bonnet pressure locking. The reason for this failure was determined to be that the computer (keyword) search was focused on problems with motor-operated valves as related to Generic Letter 89-10 (the impetus for the modification).

Written Communication: Informational presentation deficiencies.

CORRECTIVE ACTION

The specific processes which lead to the valve bonnet locking are fairly detailed and subtle. A training package and presentation on this event will be developed and given to all site engineering and system engineers. This package will include:

- Detailed description of the event.
 - Detailed description of this particular bonnet pressure locking mechanism.
 - Discussion of the failure of the industry documentation checklist to trigger appropriate review.
2. Prior to the February 10th failure of the valve, the torque switch set screws were presumed to be left loose.

The as found condition of the torque switch setting block was with the set screws loose. There was no apparent scarring of the jagged edge on the underside of the torque limiter switch that hold the screw in place. If scarring was present, that would have suggested a great amount of force to rotate the torque switch setting block and set screw from a locked position to under the limiter plate. This suggests that the screws were somehow loosened. It has never been identified in LaSalle's history with MOV's that these particular screws loosen from normal valve operation. The individuals that adjusted the torque switch setting believed that they had tightened the screws. Individuals that replaced the limiter plate and performed the different testing and inspections did not observe that the screws were loose. It can only be assumed that: 1) the screws were not tightened as tight as they should have been originally, or; 2) someone for another reason loosened the screws and failed to tighten them down.

The significance of the screws left loose played a small role in the actual valve failure in the first event. The primary significance was that the investigative team was misled, resulting in an incorrect analysis of the valve failure.

Work Practice: Self-checking could have prevented the loose screws.

CORRECTIVE ACTION

No corrective action necessary, because this is an isolated case based on MOV history.

3. The Root Cause Analysis team failed to determine the true cause of the valve failure after the first failure of the valve.

Bonnet pressure locking was originally considered but was determined less likely to occur than the scenario accepted for startup. The following reasons lead to the wrong conclusion.

- * The fact that the torque switch setting block had been found at a setting twice the acceptable value. (The torque switch setting block was originally set to a little less than two, but was found at a setting of four.) A torque setting of four could result in the shearing of the pin. Also a logical sequence of events was derived from the as found condition of the valve.

- * When the valve was inspected there was no physical evidence that the valve was internally bound. There were no signs of packing leakage or that the valve packing had experience any pressure gradient. The valve moved easily. In past experience with bonnet pressure locking, the valve would remain bound until the packing was removed to release the pressure.

Verbal Communication: Pertinent information not transmitted. Inaccurate message transmitted. Information transmitted too late.

CORRECTIVE ACTION

NO corrective action necessary.

- * Failure to identify the root cause was not due to analysis technique problems but because crucial evidence for detecting bonnet pressure locking was not available during the original investigation. Bonnet pressure locking had been considered but was discounted due to the lack of evidence. By recreating the scenario when 1E51-F063 failed to open the second time it became obvious that a bonnet pressure locking condition existed.

- * Additional root cause analysis training would not eliminate the possibility of a repeat occurrence in this situation.

EQUIPMENT PROBLEM

1. A combination of the valve design, system configuration, and system operation lead to the valve binding due to a high pressure in the valve bonnet region. The following events describe how the valve bound.

The RCIC F063 valve is normally open with steam in the line. The valve was closed to isolate the system from the reactor. As the steam line and valve cooled, the steam began to condense and collect above the upstream valve disc. During cooldown of the valve bonnet, a reverse differential pressure was developed between the above-disc water (at reactor pressure) and the bonnet area (depressurized due to cooling). This dp unseated the upper disc and allowed liquid into the bonnet. Once the work was completed, the valve was heated. The moisture that had collected in the bonnet area then expanded, pressing the disks outward binding the valve.

Design Configuration and Analysis: Equipment not designed for the environment it was used in. Inadequate failure modes and effects evaluation. Unanticipated interaction of system or components.

Plant/System Operation: Effect of changing operating parameters not properly evaluated.

CORRECTIVE ACTION

Small holes were drilled in the upper disk to prevent the pressure buildup as the valve heats up.

Evaluators Comments

The following references were used in preparing this report.

LER 93-04
LER 93-07
OSR 93-08
OSR 93-10



To: AIR 373-455-89-363RS1.2

SUBJECT: THERMAL BINDING/HYDRAULIC LOCKING OF GATE VALVES

The nine (9) previous AIR's on this subject were reviewed (see Attachment A). As a result of this review two concerns were identified.

1. Valves identified by GE SIL 368 Revision 1 were not all documented as having been evaluated.
2. More consistent criteria and verifiable methodologies are needed to identify and evaluate susceptible valves.

To ensure these concerns are addressed, the following actions were taken:

1. A screening process for thermal binding and hydraulic/pressure locking was established.
2. All Safety Related gate valves were reviewed against this screening criteria (see Attachment B).
3. The screening process was supported by a detailed evaluation prepared for each valve (see Attachment C).
4. Susceptible valves were identified (see Attachment D).
5. Additional supporting information (completed/scheduled valve modifications, testable check valve and ECCS injection valve LLRT data, EQ Zone temperature bands, PRA priorities) was gathered (see Attachment E).

Based on the results of the reviews and actions taken, as noted above, the following actions should continue to resolve this issue:

1. Develop a schedule to address all valves susceptible to either thermal binding or hydraulic/pressure locking. The schedule should set priorities based on the GL 89-10 Prioritized MOV List and the PRA (Probability Risk Assessment) value assigned to the valves.
2. Modify or analyze all subject valves taking the following into consideration: cost, GL 89-10 penalties, valve design and function.

3. A reasonable and deliberate schedule to address the subject valves is justifiable based on:
 - a. The temperature values for the EQ zones are extremely conservative and they relate to the worst case area within the zone. The EQ zones encompass large areas of the plant with room and divisional separation. Divisional separation reduces the probability that a single High Energy Line break would affect more than one valve.

There is a delay time in the conduction of heat into a valve body and subsequently the fluid in that valve body. During the first few minutes of an accident an external source of heat would have little or no affect on valve operation.
 - b. Leakage rates past ECCS Injection check valves is extremely small to zero and the Injection valves would also have to leak past the upstream disk to affect bonnet pressurization.
 - c. The valves identified as susceptible to Thermal Binding are subjected to worst case situations on a routine basis and valves that have had problems have been modified.
 - d. The probability of having multiple valve lock ups during an accident is extremely low and to cause one valve to lock up requires multiple equipment failures.

The reviews, screening, and evaluations referenced in this document were completed by the following personnel of the Site Support Engineering, Mechanical Group:

Mark Smith

Michael Hayse

Mark Dowd

AIR 373-455-89-368R1S1.2

For the purpose of this AIR, I reviewed the adequacy of the corrective actions taken associated with the AIR's listed below, pertaining to thermal binding and hydraulic locking of gate valves.

373-351-85-08500	373-455-89-368R1S1.1
373-351-85-08501	373-404-91-00015
373-402-88-00801A	373-404-91-00032
373-402-88-00801C	373-100-92-01307
373-455-88-36800	

These AIR's were generated to discuss/resolve the issue of gate valve binding/locking as addressed on SIL 368 R.1, SOER 84-7, SER 8-88, IN 92-26, INPO OE4753, and the Nuclear Network.

Per SIL No. 368 Revision 1, Supplement 1, Category 3, Dated July 19, 1989, the main concern for thermal binding and hydraulic locking occurs when these valves are closed when the system they serve is hot. The thermal binding then occurs when the system cools. Wedge type valves used for isolation may exhibit this mechanism if they must be opened soon after isolation.

When the plant is heated, pressure locking of wedge type and double disc valves can occur. Both types of gate valves are subject to this effect if the bonnet becomes filled with water.

It is important to guard against lockup in gate valves that; (a) must be opened to initiate a safety system at low reactor pressure vessel temperature or (b) protect the integrity of the reactor coolant pressure boundary.

The following valves and corresponding resolutions were provided by the above noted AIR's.

1(2)B21-F023A/B RR Pump Suction Stop

The problems encountered with failures of the RR Suction and Discharge valves are, based on word from GE, most likely due to the valves' orientation to the flow control valve and not due to thermal or hydraulic binding.

	<u>YES</u>	<u>NO</u>
<u>FURTHER INVESTIGATION/EVALUATION REQUIRED</u>	<u>X</u>	

1(2)B21-F067A/B RR Pump Discharge Stop

The problems encountered with failures of the RR Suction and Discharge valves are, based on word from GE, most likely due to the valves' orientation to the flow control valve and not due to thermal or hydraulic binding.

	<u>YES</u>	<u>NO</u>
<u>FURTHER INVESTIGATION/EVALUATION REQUIRED</u>	<u>X</u>	

1(2)CB007 LP Heater Bypass

While these valves were identified in the total population, no explanation or resolution was provided.

	<u>YES</u>	<u>NO</u>
<u>FURTHER INVESTIGATION/EVALUATION REQUIRED</u>	<u>X</u>	

1(2)E12-F003A/B RHR Hx Outlet Stop

A Modification Request (RH19) was initiated to rewire the valve to close on limit switch position instead of torque switch. This modification would prevent the motor operator from driving this non-isolation valve into its seat thereby minimizing the effect on binding.

Additionally, a Mod Request was generated to drill a hole the disc.

	<u>YES</u>	<u>NO</u>
<u>FURTHER INVESTIGATION/EVALUATION REQUIRED</u>	<u>X</u>	

1(2)E12-F004A/B/C RHR SDC

The short term solution to minimize the thermal binding is to revise the Shutdown Cooling Procedures to warn against the practice of doing vessel heat up with the Shutdown Cooling system. Procedures are currently in revision. Our Engineering Department is looking into long term solution of changing the valve design and or providing a venting mechanism for the valve. This will be a difficult process due to the valve's location below Suppression Pool level.

The bonnets for the "A" and "B" valves were subsequently provided with vents on Minor Changes MC-1-1-90-029, MC-1-1-90-030, MC-1-1-90-035, and MC-1-1-90-036.

	YES	NO
<u>FURTHER INVESTIGATION/EVALUATION REQUIRED</u>	<u>X</u>	

1(2)E12-F008 RHR SDC Outboard Isolation

These valves have not exhibited any symptoms of hydraulic locking. There are currently no plans to modify valves that are working properly.

	YES	NO
<u>FURTHER INVESTIGATION/EVALUATION REQUIRED</u>	<u>X</u>	

1(2)E12-F009 RHR SDC Inboard Isolation

The procedure for Start Up of Shutdown Cooling has been revised to include several options for opening this valve in the event that it does bind. Also because the original design improperly sized the motor, the valves' operators were modified on Modifications 1-187-044 and 1-2-88-007 to use larger motor operators which can overcome any binding forces.

	YES	NO
<u>FURTHER INVESTIGATION/EVALUATION REQUIRED</u>	<u>X</u>	

1(2)E12-F042A/B/C RHR LPCI Injection Stop

These valves have not exhibited any symptoms of hydraulic locking. There are currently no plans to modify valves that are working properly.

	YES	NO
<u>FURTHER INVESTIGATION/EVALUATION REQUIRED</u>	<u>X</u>	

1(2)E12-F047A/B RHR Hx Inlet Stop

These valves have not exhibited any symptoms of hydraulic locking. There are currently no plans to modify valves that are working properly.

	YES	NO
<u>FURTHER INVESTIGATION/EVALUATION REQUIRED</u>	<u>X</u>	

1(2)E12-F049A/B RHR Hx Building to RBEDT

These valves have not exhibited any symptoms of hydraulic locking. There are currently no plans to modify valves that are working properly.

	YES	NO
<u>FURTHER INVESTIGATION/EVALUATION REQUIRED</u>	<u>X</u>	

1(2)E21-F005 LPCS Injection Stop

These valves have not exhibited any symptoms of hydraulic locking. There are currently no plans to modify valves that are working properly.

	YES	NO
<u>FURTHER INVESTIGATION/EVALUATION REQUIRED</u>	<u>X</u>	

1(2)E22-F004 HPCS Injection Stop

These valves have not exhibited any symptoms of hydraulic locking. There are currently no plans to modify valves that are working properly.

	<u>YES</u>	<u>NO</u>
<u>FURTHER INVESTIGATION/EVALUATION REQUIRED</u>	<u>X</u>	

1(2)E32-F001A/E/J/N MSIV LCS Stop

These valves have not exhibited any symptoms of hydraulic locking. There are currently no plans to modify valves that are working properly.

	<u>YES</u>	<u>NO</u>
<u>FURTHER INVESTIGATION/EVALUATION REQUIRED</u>	<u>X</u>	

1(2)E51-F013 RCIC Injection Stop

These valves have not exhibited any symptoms of hydraulic locking. There are currently no plans to modify valves that are working properly.

	<u>YES</u>	<u>NO</u>
<u>FURTHER INVESTIGATION/EVALUATION REQUIRED</u>	<u>X</u>	

1(2)E51-F064 RCIC Steam Inlet to RHR Hx

These valves have not exhibited any symptoms of hydraulic locking. There are currently no plans to modify valves that are working properly.

	<u>YES</u>	<u>NO</u>
<u>FURTHER INVESTIGATION/EVALUATION REQUIRED</u>	<u>X</u>	

1(2)FW013 HP Heater Bypass

While these valves were identified in the total population, no explanation or resolution was provided.

	<u>YES</u>	<u>NO</u>
<u>FURTHER INVESTIGATION/EVALUATION REQUIRED</u>	<u>X</u>	

1(2)G33-F101 RWCU Suction Stop from RPV Bottom

These valves have not exhibited any symptoms of hydraulic locking. There are currently no plans to modify valves that are working properly.

	<u>YES</u>	<u>NO</u>
<u>FURTHER INVESTIGATION/EVALUATION REQUIRED</u>	<u>X</u>	

Per SIL No. 368 Revision 1 Supplement 1 Category 3, Dated July 19, 1989, the following valves (with potential malfunction) should have been reviewed for thermal binding and hydraulic binding but were not addressed by the AIRs noted on page 1:

1/2B22-F065A/B Feedwater Isolation
(Thermal Binding and Press. Locking)

The correct EID for these valves is 1/2B21-F065A/B.

1/2E11-F007 RHR Minimum Flow
(Thermal Binding and Press. Locking)

The correct EID for these valves is 1/2E12-F064A/B/C.

1/2E11-F028 RHR Pool Return
(Thermal Binding and Press. Locking)

N/A. LaSalle does not have this valve.

1/2E21-F011 Core Spray Minimum Flow
(Thermal Binding and Press. Locking)

1/2E22-F012 HPCS Minimum Flow
(Thermal Binding and Press. locking)

1/2E22-F015 HPCS Suppression Pool Suction
(Thermal Binding and Press. locking)

1/2E41-F041 HPCI Injection
(Press. locking)

N/A. LaSalle does not have a High Pressure Core Injection system.

1/2G31-F001 RWCU Inlet
(Press. Locking)

The correct EID for these valves is 1/2G33-F001.

1/2G31-F106 RWCU Inlet
(Press. Locking)

The correct EID for these valves is 1/2G33-F106.

1/2E12-F040

1/2G33-F004

Susceptibility Evaluation Criteria

Thermal Binding/Pressure Locking Conditions

Evaluation Exclusion Criteria:

1. With the exception of gate valves, all of the remaining valve designs have been excluded from the evaluation of thermal binding and pressure locking conditions.
2. All Non-Safety Related gate valves have been excluded with the exception of those Non-Safety Related gate valves in systems maintained as Safety Related.
3. Valves which have a Passive Safety Classification.
4. Valves that only have a Safety Function to close, or during plant operation they can be placed in the open position, closed during plant shutdown (if required), and reopened upon start up.

Thermal Binding Exclusion Criteria:

1. Valves that are placed in the full closed position, with the valve at or below normal room temperature.
2. Valves that have double-disc or parallel-seat design.

Part A: Thermal Binding Evaluation

- 1.a Is the required Safety Function of the valve to open from the full closed position under normal or accident conditions? (Yes/No)
- 1.b Even though the Safety Function of the valve is in the closed position, does the Emergency Operating Procedures require the valve to be reopened from the closed position? (Yes/No)
- 1.c Can the valve be closed for maintenance or operational reasons and reopened during normal unit operation? (Yes/No)
2. Is the valve placed in the full closed position with temperatures above normal room temperature? (Yes/No)
3. Is the valve disc a wedge design (solid, split, flexible)? (Yes/No)

Note: If the answers to any part of question one, and the remaining questions in Part A are yes the valve should be considered susceptible to thermal binding.

Pressure Locking Exclusion Criteria:

1. Valves that have been installed in systems with a process media containing compressible gases or fluid/gas mixtures other than steam providing the system is not initially filled with water.

Part B: Pressure Locking

- 1.a Is the required Safety Function of the valve to open from the full closed position under normal or accident conditions? (Yes/No)
- 1.b Even though the Safety Function of the valve is in the closed position, does the Emergency Operating Procedures require the valve to be reopened from the closed position? (Yes/No)
- 1.c Can the valve be closed for maintenance or operational reasons and reopened during normal unit operation? (Yes/No)
2. Is the valve susceptible to allowing fluid to enter the bonnet cavity including the area between the disc halves during valve cycling or due to differential pressure across the valve seats in the closed position? (Yes/No)

Note: Steam systems with isolated flow may condense allowing fluid to enter the bonnet cavity depending on the system and valve configuration.

3. Is the valve bonnet cavity susceptible to a higher differential pressure than both valve seats under normal or accident conditions due to temperature increases or instantaneous system pressure drops in the upstream and/or downstream piping? (Yes/No)

Note: If the answers to any part of question one, and the remaining questions in Part B are yes the valve should be considered susceptible to pressure locking.

Screening Criteria Basis

1. UFSAR 1.2.4.1 Definitions:

- a. Active Component: A safety related component characterized by an automatically initiated change of state or discernible mechanical action in response to an imposed demand.
- b. Passive Component: A safety related component characterized by no change of state nor mechanical motion.

2. Environmental Qualification List Definitions:
(Sargent & Lundy Project Instruction PI-LSNS-44 Rev. 7)

- a. Active Component: Component must perform a mechanical motion or change of state in order to accomplish its safety-related function(s).
- b. Passive Component: Component must retain its structural and pressure integrity but is not required to remain functional (i.e., component is not required to perform a mechanical motion or to change state) in order to accomplish its safety function.

Safety Related Gate Valve List

EPN	Active Passive	Thermal Binding			Pressure Locking			Envir Zone
		1	2	3	1	2	3	
1(2)B21F011A/B	P							
1(2)B21F016	A	Y(B)	Y	Y	Y(B)	Y	Y	H2A
1(2)B21F019	A	Y(B)	Y	Y	Y(B)	Y	Y	H5C
1(2)B21F065A/B	A	N	Y	Y	N	Y	Y	H5C
1(2)B21F067A/B/C/D	A	Y(B)	Y	N	Y(B)	Y	Y	H5C
1(2)B21F508A/B	P							
1(2)B33F023A/B	*P	N	Y	Y	N	Y	Y	H2A
1(2)B33F067A/B	*P	N	Y	N	N	Y	Y	H2A
1(2)CB007	*	N	Y	Y	N	Y	Y	
1(2)C11D001101	P							
1(2)C11D001102	P							
1(2)C11D001112	P							
0(1,2)DG001	P							
0(1,2)DG003	P							
0(1,2)DG004	P							
0(1,2)DG005	P							
0(1,2)DG007	P							
1(2)DG008	P							
0DG009	P							
1(2)DG011	P							
1(2)DG017	P							
1(2)DG019	P							
1(2)DG023	P							
1(2)DG032	P							
0(1,2)DO009	P							
1(2)DO016	P							
1(2)DO017	P							
1(2)DO019	P							
ODO021	P							
1(2)E12F003A/B	A	Y(BC)	N	Y	Y(BC)	Y	Y	H6
1(2)E12F004A/B/C	A	Y(C)	N	Y	Y(C)	Y	Y	H5E
1(2)E12F006A/B	A	Y(AB)	Y	Y	Y(AB)	Y	Y	H6
1(2)E12F007	P							
1(2)E12F008	A	Y(B)	Y	Y	Y(B)	Y	Y	H5B
1(2)E12F009	A	Y(B)	Y	Y	Y(B)	Y	Y	H2A
1(2)E12F011A/B	A	N	Y	Y	N	Y	Y	H6
1(2)E12F014A/B	P							
1(2)E12F016A/B	A	Y(AB)	N	Y	Y(AB)	Y	Y	H4A
1(2)E12F017A/B	A	Y(AB)	N	Y	Y(AB)	Y	Y	H4A
1(2)E12F018A/B/C	P							
1(2)E12F020	P							
1(2)E12F026A/B	A	N	N	Y	N	Y	Y	H6
1(2)E12F027A/B	A	Y(AB)	N	Y	Y(AB)	Y	Y	H6
1(2)E12F042A/B/C	A	Y(AB)	N	Y	Y(AB)	Y	Y	H4A
1(2)E12F047A/B	A	Y(C)	N	Y	Y(C)	Y	Y	H6
1(2)E12F049A/B	A	Y(B)	Y	Y	Y(B)	Y	Y	H6

*Note: These valves were evaluated as identified by previous AIRs and/or SIL 368.

EPN	Active Passive	Thermal Binding			Pressure Locking			Envir Zone
		1	2	3	1	2	3	
1(2)E12F063A/B/C	P							
1(2)E12F064A/B/C	A	Y(BC)	Y	Y	Y(BC)	Y	Y	H6
1(2)E12F067	P							
1(2)E12F068A/B	A	Y(BC)	N	Y	Y(BC)	Y	Y	H5E
1(2)E12F071A/B	P							
1(2)E12F072A/B/C	P							
1(2)E12F086	P							
1(2)E12F090A/B	P							
1(2)E12F092A/B/C	P							
1(2)E12F093	A	Y(B)	N	Y	Y(B)	Y	Y	H6
1(2)E12F094	A	Y(B)	N	Y	Y(B)	Y	Y	H6
1(2)E12F098A/B/C	P							
1(2)E12F302	P							
1(2)E12F303	P							
1E12F328B	P							
1(2)E12F330A/B/C/D	P							
1(2)E12F332A/B/C/D	P							
1(2)E12F336A/B	P							
1(2)E12F341	P							
1(2)E12F402	P							
2E12F428A/B	P							
2E12F429A/B	P							
1(2)E21F001	A	Y(C)	N	Y	Y(C)	Y	Y	H5E
1(2)E21F004	P							
1(2)E21F005	A	Y(AB)	N	Y	Y(AB)	Y	Y	H4A
1(2)E21F008	P							
1(2)E21F011	A	Y(BC)	Y	Y	Y(BC)	Y	Y	H5A
1(2)E21F051	P							
1(2)E21F052	P							
1(2)E22F003	P							
1(2)E22F004	A	Y(AB)	N	N	Y(AB)	Y	Y	H4A
1(2)E22F012	A	Y(ABC)	Y	N	Y(ABC)	Y	Y	H6
1(2)E22F015	A	Y(C)	N	N	Y(C)	Y	Y	H5E
1(2)E22F019	P							
1(2)E22F026	P							
1(2)E22F031	P							
1(2)E22F038	P							
1(2)E22F310	P							
1(2)E22F311	P							
1(2)E22F312	P							
1(2)E22F313	P							
1(2)E22F315	P							
1(2)E22F316	P							
1(2)E22F319	P							
1(2)E22F325	P							
1(2)E32F001A/E/J/N	A	Y(A)	N	Y	Y(A)	Y	Y	H5C
1(2)E32F002A/E/J/N	A	Y(A)	N	Y	Y(A)	Y	Y	H5C
1(2)E32F003N	A	Y(A)	N	Y	Y(A)	Y	Y	H5C
1(2)E32F006	A	Y(A)	N	Y	Y(A)	Y	Y	H5C
1(2)E32F007	A	Y(A)	N	Y	Y(A)	Y	Y	H5C
1(2)E51F008	A	Y(BC)	Y	N	Y(BC)	Y	Y	H5B
1(2)E51F009	P							
1(2)E51F010	A	Y(BC)	N	Y	Y(BC)	Y	Y	H5A
1(2)E51F012	P							

EPN	Active Passive	Thermal Binding			Pressure Locking			Envir Zone
		1	2	3	1	2	3	
1(2)E51F013	A	Y(A)	N	Y	Y(A)	Y	Y	H4A
1(2)E51F016	P							
1(2)E51F031	A	Y(AB)	N	Y	Y(AB)	Y	Y	H5E
1(2)E51F059	A	Y(B)	N	Y	Y(B)	Y	Y	H5A
1(2)E51F063	A	Y(BC)	Y	N	Y(BC)	Y	Y	H2A
1(2)E51F064	A	N	Y	Y	N	Y	Y	H5B
1(2)E51F068	A	Y(C)	Y	Y	Y(C)	N	Y	H5E
1(2)E51F356	P							
2E51F357	P							
1(2)E51F362	P							
1(2)E51F363	P							
1(2)FC040A/B	P							
1(2)FC042A/B	P							
1(2)FC045A/B	P							
1(2)FC047A/B	P							
1(2)FC0 5	P							
1(2)FC1 5	P							
1(2)FC139A/B	P							
1(2)FC140	P							
1(2)FW013	*	N	Y	Y	N	Y	Y	
1(2)G33F001	A	Y(BC)	Y	N	Y(BC)	Y	Y	H2A
1(2)G33F004	A	Y(BC)	Y	N	Y(BC)	Y	Y	H5D
1(2)G33F040	A	Y(BC)	Y	Y	Y(BC)	Y	Y	H5C
1(2)G33F100	P							
1(2)G33F101	*P	N	Y	Y	N	Y	Y	H2A
1(2)G33F106	P							
1(2)HG001A/B	A	Y(AB)	N	Y	Y(AB)	N	Y	H4A
1(2)HG003	A	Y(C)	N	Y	Y(C)	N	Y	H4A
1(2)HG005A/B	A	Y(A)	N	Y	Y(A)	N	Y	H5E
1(2)HG006A/B	A	Y(A)	N	Y	Y(A)	N	Y	H5E
1(2)HG009	A	Y(AB)	N	Y	Y(AB)	N	Y	H4A
1(2)MC027	P							
1(2)MC033	P							
1(2)SA042	P							
1(2)SA046	P							
0VC025A/B/C/D	P							
1(2)VG008	P							
1(2)VG009	P							
1(2)VG010	P							
1(2)VG011	P							
1(2)VG012	P							
1(2)VG013	P							
1(2)VG014	P							
1(2)VG015	P							
1(2)VP053A/B	A	Y(BC)	N	Y	Y(BC)	Y	Y	H4A
1(2)VP063A/B	A	Y(BC)	N	Y	Y(BC)	Y	Y	H4A
1(2)WR029	A	N	N	Y	N	Y	Y	H4A
1(2)WR040	A	N	N	Y	N	Y	Y	H4A
1(2)WR179	A	N	N	Y	N	Y	Y	H2A
1(2)WR180	A	N	N	Y	N	Y	Y	H2A

*Note: These valves were evaluated as identified by previous AIRs and/or SIL 368.

STEAM VALVE SCREENING

1. Is the valve installed in a vertical run of piping?
2. Is the valve installed on a horizontal run of piping, with the actuator installed in any position other than a straight up vertical position?
3. Is the valve installed in a low point in the system, where steam may condense and water gather at the valve?

If the answers to questions 1 through 3 are no then the valve is not considered to be susceptible to having water enter the bonnet cavity.

Attachment B

VALVE NO.	QUESTION NUMBER		
	1	2	3
1(2)B21-F016	NO	NO	YES
1(2)B21-F019	NO	NO	YES
1(2)B21-F067A	NO	NO	YES
1(2)B21-F067B	NO	NO	YES
1(2)B21-F067C	NO	NO	YES
1(2)B21-F067D	NO	NO	YES
1E32-F001A	NO	YES (22)	YES
2E32-F001A	NO	YES (20)	YES
1E32-F001E	NO	YES (14)	YES
2E32-F001E	NO	YES (20)	YES
1E32-F001J	NO	YES (15)	YES
2E32-F001J	NO	YES (20)	YES
1E32-F001N	NO	YES (09)	YES
2E32-F001N	NO	YES (20)	YES
1(2)E32-F002A	NO	YES (45)	YES
1(2)E32-F002E	NO	YES (45)	YES
1(2)E32-F002J	NO	YES (45)	YES
1(2)E32-F002N	NO	YES (45)	YES
1(2)E32-F003N	NO	NO	YES
1(2)E32-F006	NO	NO	YES
1(2)E32-F007	NO	NO	YES
1(2)E51-F008	NO	NO	YES
1(2)E51-F063	YES	NO	YES
1(2)E51-F064	NO	NO	YES
1(2)E51-F068	NO	NO	NO

QUESTION 2 OPERATOR ORIENTATION

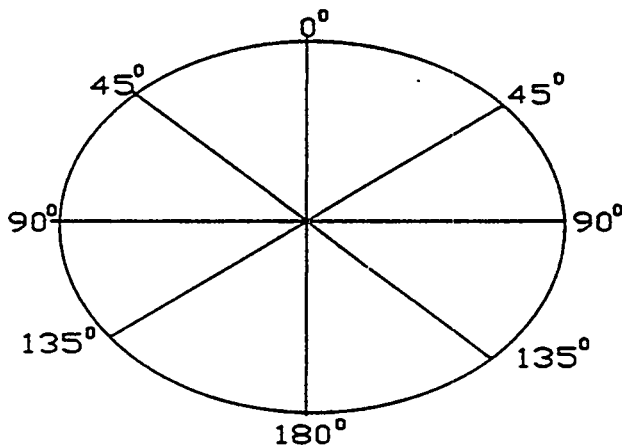

Qualification Requirements of Screening Personnel

1. Senior Reactor Operators License with two years operating experience.
2. Valve expert with two years maintenance experience.
3. BS Engineering degree.
4. Two Persons required to screen valve susceptibility. They must cover the qualifications as stated in items 1-3.

Screening Personnel

1. Mark Dowd - SRO since 1983, 11 years on shift operating experience, BS General Engineering University of Illinois 1978.
2. Mark Smith - 7 years Maintenance Mechanic, 6 years Maintenance Supervisor, 2 years valve component expert for Site Engineering at LaSalle Station.
3. Mike Hayse - 15 years Quality Assurance and Quality Control experience.

ATTACHMENT B

Differential Temperature Screening Criteria

1. Is there a heat sink on one side of the valve (i.e., large pool of water or a flow stream)?
2. Is there a heat source on one side of the valve that can transmit heat to one side of the valve?

NOTE

Heat sources can transmit heat long distances in stagnant legs if it is done via convective heat transfer.

If answers to questions 1 and 2 are both yes then the valve is subject to a differential temperature.

ATTACHMENT B

VALVE NO.	QUESTION NUMBER	
	<u>1</u>	<u>2</u>
1 (2) E12-F042A/B/C	N	N
1 (2) E21-F005	N	N
1 (2) E22-F004	N	N
1 (2) E51-F013	N	N
1 (2) E12-F016A/B	N	N
1 (2) E12-F017A/B	N	N
1 (2) E12-F027A/B	N	Y
1 (2) E12-F068A/B	Y	N
1 (2) E12-F003A/B	Y	Y
1 (2) E12-F004A/B/C	Y	Y
1 (2) E12-F006A/B	Y	N
1 (2) E12-F008	N	N
1 (2) E12-F009	N	Y
1 (2) E12-F011A/B	Y	Y
1 (2) E12-F026A/B	N	Y
1 (2) E12-F047A/B	Y	Y
1 (2) E12-F049A/B	N	N
1 (2) E12-F064A/B/C	Y	Y
1 (2) E12-F093	Y	N
1 (2) E12-F094	N	N
1 (2) E21-F001	Y	N
1 (2) E21-F011	Y	N
1 (2) E22-F012	Y	N
1 (2) E22-F015	Y	N
1 (2) E51-F008	N	N
1 (2) E51-F063	N	Y
1 (2) E51-F010	Y	N
1 (2) E51-F031	Y	N
1 (2) E51-F059	Y	N
1 (2) E51-F064	N	Y
1 (2) E51-F068	N	Y
1 (2) G33-F001	N	Y
1 (2) G33-F004	N	Y
1 (2) G33-F040	N	Y
1 (2) G33-F101	N	Y
1 (2) HG001A/B	N	N
1 (2) HG003	N	N
1 (2) HG009	N	N

ATTACHMENT B

<u>VALVE NO.</u>	<u>QUESTION NUMBER</u>	
	<u>1</u>	<u>2</u>
1 (2) HG005A/B	Y	N
1 (2) HG006A/B	N	N
1 (2) VP053A/B	N	N
1 (2) VP063A/B	N	N
1 (2) WR029	N	N
1 (2) WR040	N	N
1 (2) WR179	N	N
1 (2) WR180	N	N
1 (2) E32-F001A/E/J/N	N	Y
1 (2) E32-F002A/E/J/N	N	Y
1 (2) E32-F003N	N	Y
1 (2) E32-F006	N	Y
1 (2) E32-F007	N	Y
1 (2) B21-F016	N	Y
1 (2) B21-F019	N	Y
1 (2) B21-F067A/B/C/D	N	Y
1 (2) B21-F065A/B	N	Y
1 (2) B33-F023A/B	N	Y
1 (2) B33-F067A/B	N	Y
1 (2) CB007	N	Y
1 (2) FW013	N	Y

1(2)E12-F042 A/B/C

A. Thermal Binding Evaluation

- 1.a The safety function of these valves is to open from the full closed position.
- 1.b The EOP's require the LPCI Injection Valves to open during accident conditions.
- 1.c Not applicable as these valves are normally closed.
2. The LPCI Injection Valves are closed on Unit start up at normal room temperature conditions and are not cycled during normal Unit operations.
3. The LPCI Injection Valves are 12" motor operated flex wedge gate valves.

B. Hydraulic Locking Evaluation

- 1.a The safety function of these valves is to open from the full closed position.
- 1.b The EOP's require the LPCI Injection Valves to open during accident conditions.
- 1.c Not applicable as these valves are normally closed.
2. The LPCI Injection Valves are in a water filled system, therefore the bonnet cavities can be assumed to be filled with water.
3. The LPCI Injection Valves are in EQ zone H4A, with a postulated temperature range of 94 degf to 145 degf. Based on that temperature rise, a more specific temperature profile will be required to determine hydraulic locking susceptibility.

Based on present leak rate testing methodology, more detailed testing and instrumentation will be required to determine if the valve bonnet cavities are subjected to Reactor pressure and would then be susceptible to a rapid depressurization form of hydraulic locking.

1(2)E21-F005**A. Thermal Binding Evaluation**

- 1.a The safety function of this valve is to open from the full closed position.
- 1.b The EOP's require the LPCS Injection Valve to open during accident conditions.
- 1.c Not applicable as this valve is normally closed.
2. The LPCS Injection Valve is closed on Unit start up at normal room temperature conditions and is not cycled during normal Unit operations.
3. The LPCS Injection Valve is a 12" motor operated flex wedge gate valve.

B. Hydraulic Locking Evaluation

- 1.a The safety function of this valve is to open from the full closed position.
- 1.b The EOP's require the LPCS Injection Valve to open during accident conditions.
- 1.c Not applicable as this valve is normally closed.
2. The LPCS Injection Valve is in a water filled system, therefore the bonnet cavity can be assumed to be filled with water.
3. The LPCS Injection Valve is in EQ zone H4A with a postulated temperature range of 94 degf to 145 degf. Based on that temperature rise, a more specific temperature profile will be required to determine hydraulic locking susceptibility.

Based on present leak rate testing methodology, more detailed testing and instrumentation will be required to determine if the valve bonnet cavity is subjected to Reactor pressure and would then be susceptible to a rapid depressurization form of hydraulic locking.

1(2)E22-F004**A. Thermal Binding Evaluation**

- 1.a The safety function of this valve is to open from the full closed position.
- 1.b The EOP's require the HPCS Injection Valve to open during accident conditions.
- 1.c Not applicable as this valve is normally closed.
2. The HPCS Injection Valve is closed on Unit start up at normal room temperature conditions and is not cycled during normal Unit operations. LaSalle Station has experienced events where the HPCS system has successfully injected while the Reactor has been at rated temperature and pressure.
3. The HPCS Injection Valve is a 12" motor operated double-disc gate valve.

B. Hydraulic Locking Evaluation

- 1.a The safety function of this valve is to open from the full closed position.
- 1.b The EOP's require the HPCS Injection Valve to open during accident conditions.
- 1.c Not applicable as this valve is normally closed.
2. The HPCS Injection Valve is in a water filled system, therefore the bonnet cavity can be assumed to be filled with water.
3. The HPCS Injection Valve is in EQ zone H4A with a postulated temperature range of 94 degf to 145 degf. Based on that temperature rise, a more specific temperature profile will be required to determine hydraulic locking susceptibility.

Based on present leak rate testing methodology, more detailed testing and instrumentation will be required to determine if the valve bonnet cavity is subjected to Reactor pressure and would then be susceptible to a rapid depressurization form of hydraulic locking.

1(2)E51-F013

A. Thermal Binding Evaluation

- 1.a The safety function of this valve is to open from the full closed position.
- 1.b The EOP's require the RCIC Injection Valve to open during accident conditions.
- 1.c Not applicable as this valve is normally closed.
2. The RCIC Injection Valve is closed on Unit start up at normal room temperature conditions and is not cycled during normal Unit operations. LaSalle Station has experienced events where the RCIC system has successfully injected while the Reactor has been at rated temperature and pressure.
3. The RCIC Injection Valve is a 6" motor operated flex wedge gate valve.

B. Hydraulic Locking Evaluation

- 1.a The safety function of this valve is to open from the full closed position.
- 1.b The EOP's require the RCIC Injection Valve to open during accident conditions.
- 1.c Not applicable as this valve is normally closed.
2. The RCIC Injection Valve is in a water filled system, therefore the bonnet cavity can be assumed to be filled with water.
3. The RCIC Injection Valve is in EQ zone H4A with a postulated temperature range of 94 degf to 145 degf. Based on that temperature rise, a more specific temperature profile will be required to determine hydraulic locking susceptibility.

Based on present leak rate testing methodology, more detailed testing and instrumentation will be required to determine if the valve bonnet cavity is subjected to Reactor pressure and would then be susceptible to a rapid depressurization form of hydraulic locking.

1(2)E12-F016A/B

A. Thermal Binding Evaluation

- 1.a The safety function of these valves is to open for Drywell spray operation and close for Primary Containment isolation.
- 1.b The EOP's require these valves to open during accident conditions.
- 1.c Not applicable as this valve is normally closed.
2. The Drywell Spray Valves are closed on Unit start up at normal room temperature conditions and are not cycled during normal Unit operations.
3. The Drywell Spray Valve is a 16" motor operated flex wedge gate valve.

B. Hydraulic Locking Evaluation

- 1.a The safety function of these valves is to open for Drywell spray operation and close for Primary Containment isolation.
- 1.b The EOP's require these valves to open during accident conditions.
- 1.c Not applicable as this valve is normally closed.
2. The Drywell Spray Valves are in a water filled system, therefore the bonnet cavities can be assumed to be filled with water.
3. The Drywell Spray Valve is in EQ zone H4A with a postulated temperature range of 94 degf to 145 degf. Based on that temperature rise, a more specific temperature profile will be required to determine hydraulic locking susceptibility.

The Drywell Spray Valve can not be subjected to Reactor pressure, therefore it is not susceptible to a rapid depressurization form of hydraulic lock.

AIR 373-455-89-363RS1.2

ATTACHMENT D

1. Approximately 10 types of valves were determined to be susceptible to Thermal Binding. The susceptible valves are tabulated below.
2. Approximately 40 types of valves were determined to be susceptible to Pressure Locking. The susceptible valves are tabulated below.

Thermal Binding	Pressure Locking
1 (2) B21-F016	1 (2) B21-F016
1 (2) B21-F019	1 (2) B21-F019
1 (2) E11-F006A/B	1 (2) B21-F067A/B/C/D
1 (2) E12-F008	1 (2) E12-F003A/B
1 (2) E12-F009	1 (2) E12-F004A/B/C
1 (2) E12-F049A/B	1 (2) E12-F006A/B
1 (2) E12-F064A/B/C	1 (2) E12-F008
1 (2) E21-F011	1 (2) E12-F009
1 (2) E51-F068	1 (2) E12-F016A/B
1 (2) G33-F040	1 (2) E12-F017A/B
	1 (2) E12-F027A/B
	1 (2) E12-F042A/B/C
	1 (2) E12-F047A/B
	1 (2) E12-F049A/B
	1 (2) E12-F064A/B/C
	1 (2) E12-F068A/B
	1 (2) E12-F093
	1 (2) E12-F094
	1 (2) E21-F001
	1 (2) E21-F004
	1 (2) E21-F011
	1 (2) E22-F004
	1 (2) E22-F012
	1 (2) E22-F015
	1 (2) E32-F001A/E/J/N
	1 (2) E32-F002A/E/J/N
	1 (2) E32-F003N
	1 (2) E32-F006
	1 (2) E32-F007
	1 (2) E51-F008
	1 (2) E51-F010
	1 (2) E51-F013
	1 (2) E51-F031
	1 (2) E51-F059
	1 (2) E51-F063
	1 (2) G33-F040
	1 (2) G33-F004
	1 (2) G33-F040
	1 (2) VP053A/B
	1 (2) VP063A/B

Thermal Binding

1(2)B21-F016
1(2)B21-F019
1(2)E12-F006A/B
1(2)E12-F008
1(2)E12-F009
1(2)E12-F049A/B
1(2)E12-F064A/B/C*
1(2)E21-F011
1(2)E51-F068
1(2)G33-F040

NOTE

* Denotes valves susceptible to Differential Temperature Thermal Binding and Classic Thermal Binding

Valves susceptible to Differential Temperature Thermal Binding.

1(2)E12-F003A/B
1(2)E12-F004A/B/A
1(2)E12-F047A/B

Pressure Locking

1(2)B21-F016
1(2)B21-F019
1(2)B21-F067A/B/C/D
1(2)E12-F003A/B
1(2)E12-F004A/B/C
1(2)E12-F006A/B
1(2)E12-F008
1(2)E12-F009
1(2)E12-F016A/B
1(2)E12-F017A/B
1(2)E12-F027A/B
1(2)E12-F042A/B/C
1(2)E12-F047A/B
1(2)E12-F049A/B
1(2)E12-F064A/B/C
1(2)E12-F068A/B
1(2)E12-F093
1(2)E12-F094
1(2)E21-F001
1(2)E21-F005
1(2)E21-F011
1(2)E22-F004
1(2)E22-F012
1(2)E22-F015
1(2)E32-F001A/E/J/N
1(2)E32-F002A/E/J/N
1(2)E32-F003N
1(2)E32-F006
1(2)E32-F007
1(2)E51-F008
1(2)E51-F010
1(2)E51-F013
1(2)E51-F031
1(2)E51-F059
1(2)E51-F063
1(2)G33-F001
1(2)G33-F004
1(2)G33-F040
1(2)VP053A/B
1(2)VP063A/B

Modified Valves

EPN	Change	Initiater	Doc.Number	Date
1E12-F003A	close on limits 95%	DVR 1-1-83-342&387	M01-1-86-005 TSC1-708-83	5\30\88
1E12-F003B	close on limits 95%	DVR 1-1-83-342&387	M01-1-86-005 TSC1-708-83	5\30\88
2E12-F003A	close on limits 95%	DVR 1-1-83-342&387	M01-2-88-018 TSC2-756-86	1\6\89
2E12-F003B	close on limits 95%	DVR 1-1-83-342&387	M01-2-88-018 TSC2-756-86	1\6\89
1E12-F004A	Bonnet Vent &Proc. Rev.	DVR 1-2-89-0047	P01-1-90-036	1\13\92
1E12-F004B	Bonnet Vent &Proc. Rev.	DVR 1-2-89-0047	P01-1-90-029	12\31\91
2E12-F004A	Bonnet Vent &Proc. Rev.	DVR 1-2-89-0047	P01-2-90-035	3\19\92
2E12-F004B	Bonnet Vent &Proc. Rev.	DVR 1-2-89-0047	P01-2-90-030	3\24\92
1E12-F009	Larger Motor Op & Proc. Rev.	GL 89-10 & LLRT concern Vlv. Bind	M01-1-87-044	9\23\87
2E12-F009	Larger Motor Op & Proc. Rev.	GL 89-10 & LLRT concern Vlv. Bind	M01-2-88-007	1\26\89
1G33-F001	Flex wedge to Dbl.Disc	GL 89-10 & LLRT concern	P01-1-91-516	12\11\92

1G33-F004	Flex wedge to Dbl.Disc	GL 89-10 & LLRT concern	P01-1-91-517	12\10\92
2G33-F001	Flex wedge to Dbl.Disc	GL 89-10 & LLRT concern	P01-2-91-506	3\5\92
2G33-F004	Flex wedge to Dbl.Disc	GL 89-10 & LLRT concern	P01-2-91-507	3\5\92
1E51-F008	Flex wedge to Dbl.Disc	GL 89-10 & LLRT concern	P01-1-91-518	1\4\93
2E51-F008	Flex wedge to Dbl.Disc	GL 89-10 & LLRT concern	P01-2-91-508	L2R05
1E51-F063	Flex wedge to Dbl.Disc Drill two holes in upstrm disc	GL 89-10 & LLRT concern Press.lock DVR1-1-93-0023	P01-1-91-519 EC-93-004	1\7\93 3\8\93
2E51-F063	Flex wedge to Dbl.Disc	GL 89-10 & LLRT concern	P01-2-91-509	L2R05
1B21-F067A	Globe to Dbl.Disc.	LLRT Failures	CR-90-120	1\8\93
1B21-F067B	Globe to Dbl.Disc.	LLRT Failures	CR-90-117	1\8\93
1B21-F067C	Globe to Dbl.Disc.	LLRT Failures	CR-90-118	1\8\93
1B21-F067D	Globe to Dbl.Disc.	LLRT Failures	CR-90-119	1\8\93
2B21-F067A	Globe to Dbl.Disc.	LLRT Failures	CR-90-127	3\27\92
2B21-F067B	Globe to Dbl.Disc.	LLRT Failures	CR-90-124	3\27\92
2B21-F067C	Globe to Dbl.Disc.	LLRT Failures	CR-90-125	3\27\92

2B21-F067D	Globe to Dbl.Disc.	LLRT Failures	CR-90-126	3\27\92

Local Leak Rate Data

VALVE (EPN)	AIR LLRT (SCFH)	WATER LLRT (GPM)
1E12-F041A	-----	12\6\92 0.1 GPM
1E12-F042A	10\23\92 0.0 SCFH	10\22\92 0.25 GPM
1E12-F041B	-----	10\12\92 0.0 GPM
1E12-F042B	11\24\92 3.53 SCFH	11\25\92 0.06 GPM
1E12-F041C	-----	10\9\92 0.0 GPM
1E12-F042C	11\21\92 6.5 SCFH	11\23\92 0.05 GPM
1E21-F006	-----	12\3\92 0.0 GPM
1E21-F005	11\17\92 2.51 SCFH	11\16\92 0.1GPM
1E22-F005	-----	10\8\92 0.0 GPM
1E22-F004	12\21\92 0.0 SCFH	12\21\92 0.0 GPM
1E51-F065	-----	12\26\92 0.0 GPM
1E51-F066	-----	12\26\92 0.74 GPM
1E51-F013	12\31\92 0.65 SCFH	-----
2E12-F041A	-----	1\17\92 0.0 GPM
2E12-F042A	2\23\92 0.47 SCFH	2\23\92 0.1 GPM
2E12-F041B	-----	2\27\92 0.0 GPM
2E12-F042B	2\25\92 0.0 SCFH	2\27\92 0.0 GPM
2E12-F041C	-----	3\3\92 0.2 GPM
2E12-F042C	1\20\92 0.0 SCFH	1\20\92 0.5 GPM
2E21-F006	-----	1\11\92 0.0 GPM
2E21-F005	1\11\92 0.0 SCFH	1\11\92 0.0 GPM
2E22-F005	-----	1\8\92 0.0 GPM
2E22-F004	1\25\92 0.0 SCFH	1\28\92 0.0 GPM
2E51-F065	-----	3\19\92 0.0 GPM
2E51-F066	-----	3\13\92 0.1 GPM 9\5\92 0.1 GPM
2E51-F013	1\16\92 1.54 SCFH	-----

<u>ZONE</u>	<u>LOCATION</u>	<u>MAXIMUM TEMPERATURE NON-ACCIDENT PERIODS (Deg. F)</u>	<u>MAXIMUM TEMPERATURE DURING AN ACCIDENT (Deg. F)</u>
H1	Inside the RPV	546	581
H2	Inside Primary Containment-Drywell	135	330
H3	Inside Primary Containment-Wetwell	100	212
H4	Reactor Bldng. General Areas	94	145
H5	HELB Local Areas		
	H5A LPCS/RCIC Cubicle	100	212
	H5B RCIC Pipe Tunnel	136	212
	H5C Main Steam Tunnel	106	212
	H5D RWCU Equip. Areas	107	212
	H5E Basement & Upper Basement Outside ECCS Equip. Cubicles	94	212
H6	Reactor Bldng. ECCS Cubicles	99	148
H7	Turbine Bldng. Limited Access Areas	83	212
H8	Turbine Bldng. General Access Areas	225	212
H9	Auxiliary Bldng.	106	106

PRA PRIORITIES/VALUES

<u>I HIGH</u>	<u>II MEDIUM</u>	<u>III LOW</u>	<u>IV LOW-LOW</u>	<u>V DELETE</u>
E22-F004	E21-F011	E12-F004A	E51-F022	E12-F011A
E12-F068A	E12-F064A	E12-F004B	E51-F059	E12-F011B
E12-F068B	E12-F064B	E21-F001	E51-F069	E12-F052A
E12-F024A	E12-F064C	E12-F004C	E12-F023	E12-F052B
E12-F024B	E51-F013	E22-F015	VQ-032	E12-F026A
E12-F048A	E51-F019	E51-F063	VQ-035	E12-F026B
E12-F048B	E51-F045	E51-F008	VQ-068	E12-F087A
E21-F005	E51-F046	E51-F010	E51-F076	E12-F087B
E12-F042A	E22-F023	E51-F031	E12-F040A	E51-F064
E12-F042B	E22-F012	E51-F068	E12-F040B	2E51-F091
E12-F042C	E21-F012	E51-F36C	E12-F049A	E22-F001
	E12-F021	E12-F027A	E12-F049B	E22-F010
	E12-F016A	E12-F027B	VQ-050	E22-F011
	E12-F016B	G33-F001	VQ-051	VG-001
	E12-F017A	G33-F004	B21-F065A	VG-002
	E12-F017B	B21-F067A	B21-F065B	DG035
		B21-F067B	E12-F073A	
		B21-F067C	E12-F073B	
		B21-F067D	E12-F074A	
		B21-F016	E12-F074B	
		B21-F019	E32-F001A	
		VP-53A	E32-F001E	
		VP-53B	E32-F001J	
		VP-63A	E32-F001N	
		VP-63B	VQ-037	
		VP-113A	VQ-038	
		VP-113B	E12-F093	
		VP-114A	E12-F094	
		VP-114B	E12-F312A	
		G33-F040	E12-F312B	
		WR-029	HG-001A	
		WR-40	HG-001B	
		WR-179	HG-002A	
		WR-180	HG-002B	
		VQ-047	HG-003	
		VQ-048	HG-005A	
		E51-F080	HG-005B	
		E51-F086	HG-006A	
		E12-F008	HG-006B	

PRA PRIORITIES/VALUES

<u>I</u> <u>HIGH</u>	<u>II</u> <u>MEDIUM</u>	<u>III</u> <u>LOW</u>	<u>IV</u> <u>LOW-LOW</u>	<u>V</u> <u>DELETE</u>
		E12-F009	HG-009	
		E12-F006A	HG-018	
		E12-F006B	HG-025	
		E12-F053A	HG-026	
		E12-F053B	HG-027	
		E12-F003A	E32-F002A	
		E12-F003B	E32-F002E	
		E12-F099A	E32-F002J	
		E12-F099B	E32-F002N	
		E12-F047A	E32-F003A	
		E12-F047B	E32-F003E	
		C41-F001A	E32-F003J	
		C41-F001B	E32-F003N	
			E32-F006	
			E32-F007	
			E32-F008	
			E32-F009	

**LASALLE COUNTY STATION
PRESSURE LOCKING AND THERMAL BINDING OF GATE VALVES**

VALVE SUMMARY				
VALVE	LINE NO.	DRAWING	VALVE ELEV.	ZONE
1E12F068A	1RH83AA-20"	M-227/237	685'	H5E
1E12F068B	1RH83AB-20"	M-225/234	689'	H6
2E12F068A	2RH83AA-20"	M-231/243	685'	H5E
2E12F068B	2RH83AB-20"	M-229/240	689'	H6

The applicable environmental zones (H5E, H6) are identified in Figure 3.11-1, sheet 6 of 7 and Figure 3.11-4 of the LSCS UFSAR.

H6

Per the UFSAR, H6 is not subjected to adverse temperature conditions as a result of a LOCA or HELB. The cubicle of interest in Zone H6 which contains valves 1(2)E12F068B is the southeast cubicle (RHR-BC Equipment Room) which is provided with a dedicated, safety-related cubicle cooler.

The 148 F design temperature given is for when the pumps in this room are running, consequently valve E12-F068B is already open. These valves would be expected to be at the corner room temperature. The normal room temperature provided by VR is approx. 120 F.

H5E

For Zone H5E (Valves 1(2)E12F068A), the peak temperature following a LOCA is 155°F per Calc. No. 3C7-0185-001, EQ conditions for reactor building (674'-0" and 694'-6" elevations) for LOCA in containment.

Based on an initial assessment, it does not appear that Zone H5E would be subjected to adverse temperature conditions as a result of an HELB, therefore, temperature relief from the 212°F documented in Table 3.11-7 of the UFSAR may be possible. However, a more detailed review would be required to confirm this.

Actual line break locations need to be verified for lines located in the vicinity of the E12-F068A valve. A few RI lines breaks have been verified to be on different elevations. We still need to look

**Valve Bonnet Internal Pressure, Flooded Bonnet, Condensing Heat Transfer Coefficient
(HTC = 1120), Temperature : 84 - 148 F**

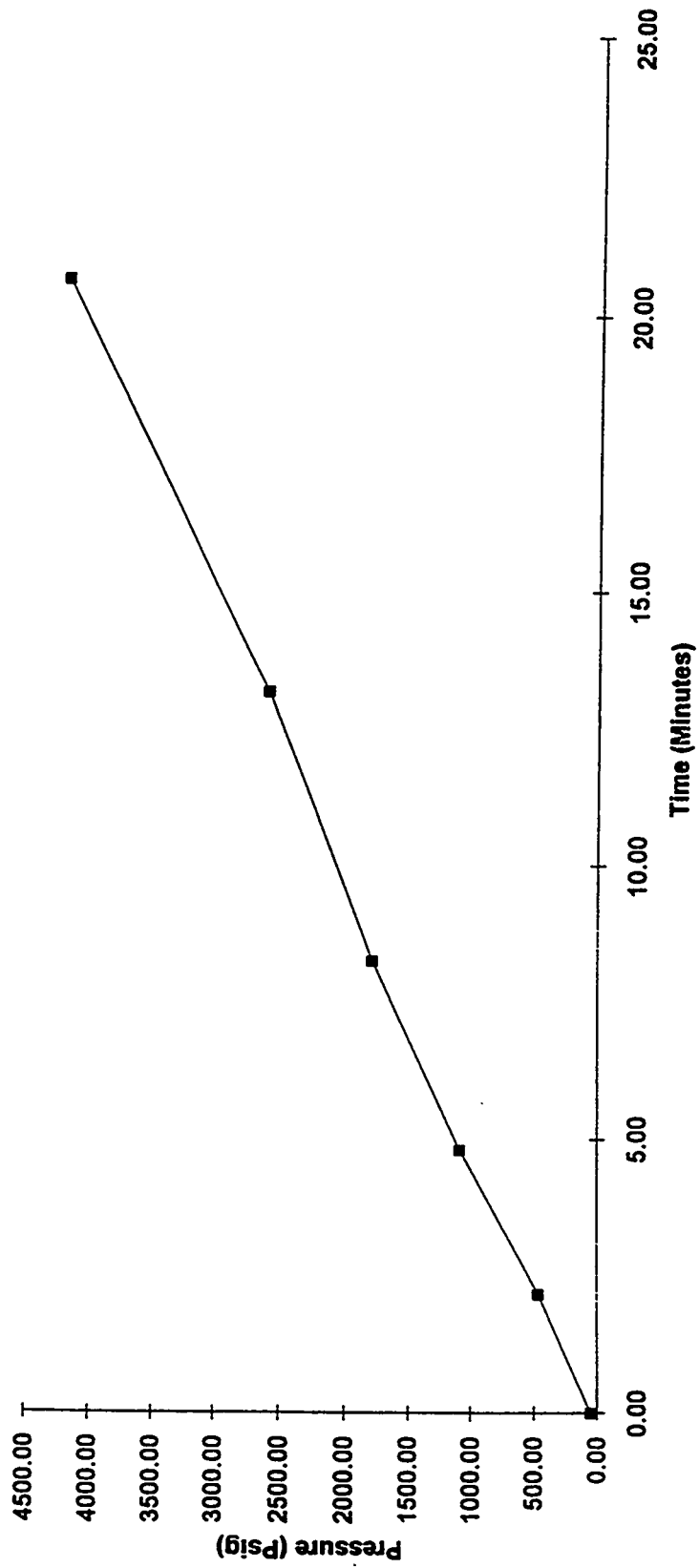

**Valve Bonnet Fluid Temperature, Flooded Bonnet, Condensing Heat Transfer Coefficient
(HTC = 1120), Temperature : 84 - 148 F**

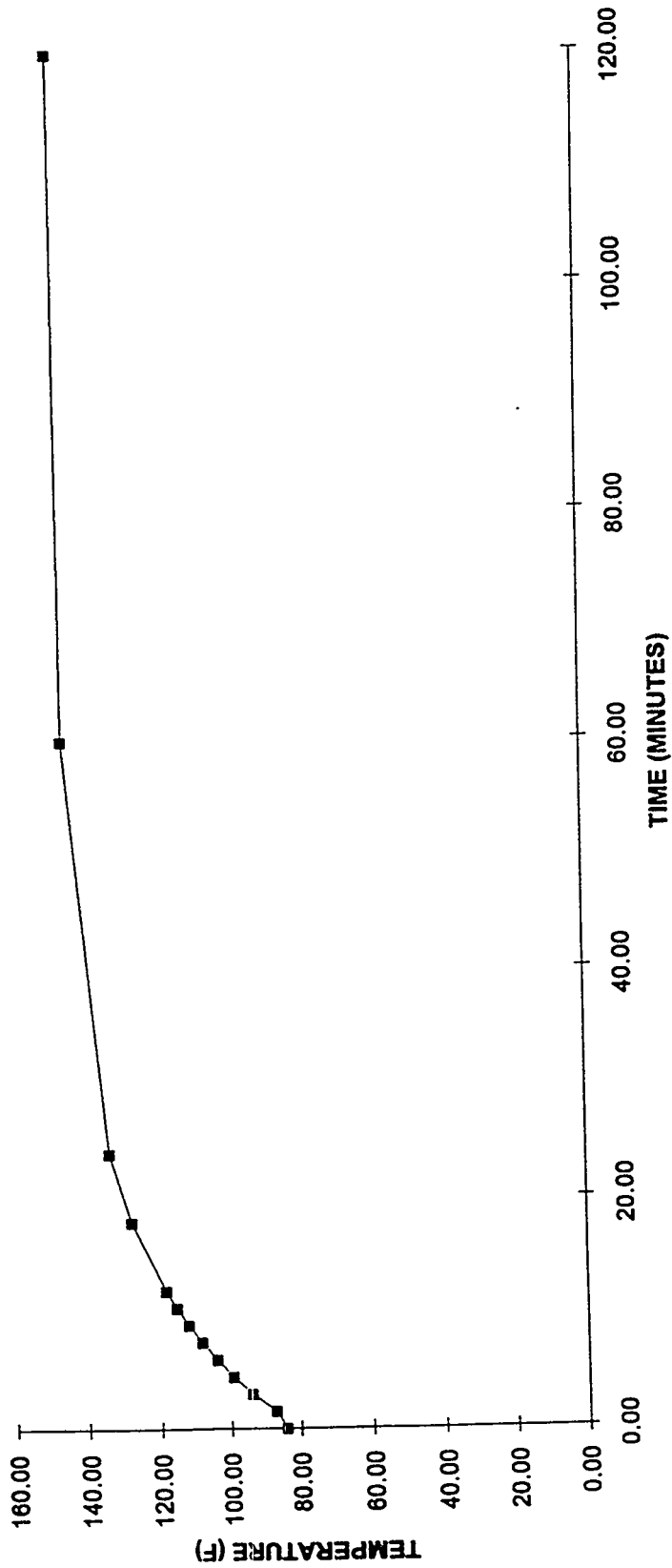

**Valve Bonnet Internal Pressure, Flooded Bonnet, Dry Bonnet Surface (HTC = 100),
Temperature : 84 - 148 F**

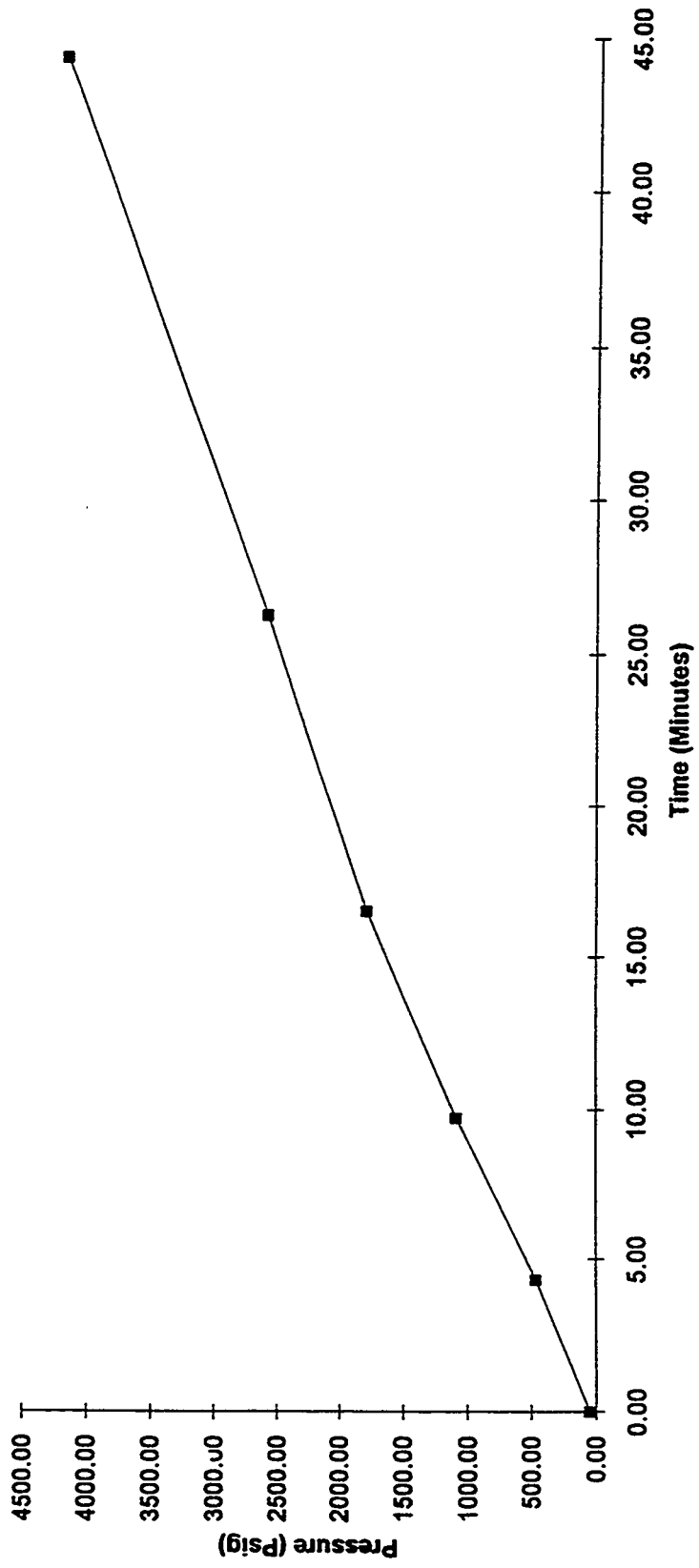

Valve Bonnet Fluid Temperature, Flooded Bonnet, Dry Bonnet Surface (HTC = 100),
Temperature : 84 - 148 F

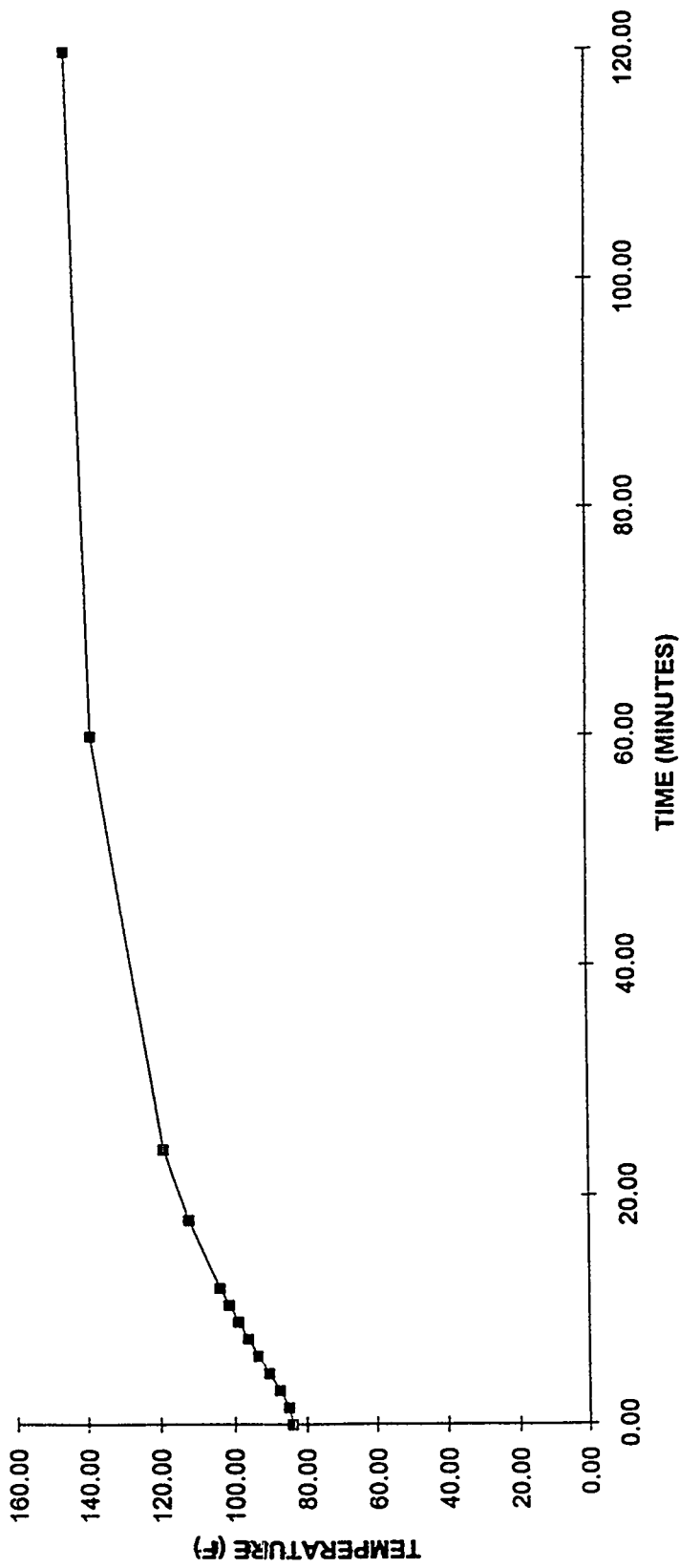

**Bonnet Internal Pressure vs. Time, Bonnet Vol. = 5.32 ft³, Initial Water Vol. = 5.0035 ft³,
Initial Air Vol. = 0.3165 ft³, Maximum Temperature = 212 F**

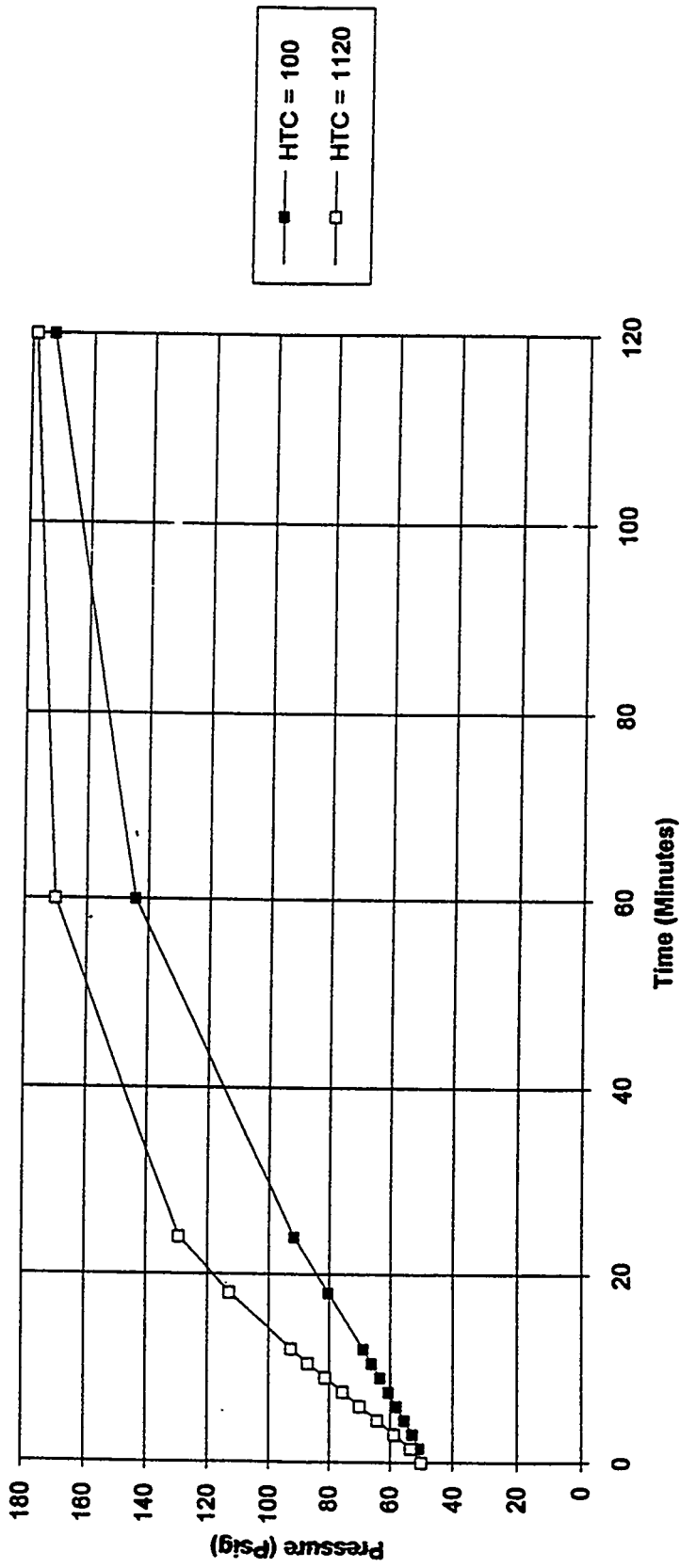

Bonnet Fluid Temperature vs. Time, Bonnet Vol. = 5.32 ft³, Initial Water Vol. = 5.0035ft³, Initial Air Vol. = 0.3165ft³, Maximum Temperature = 212 F

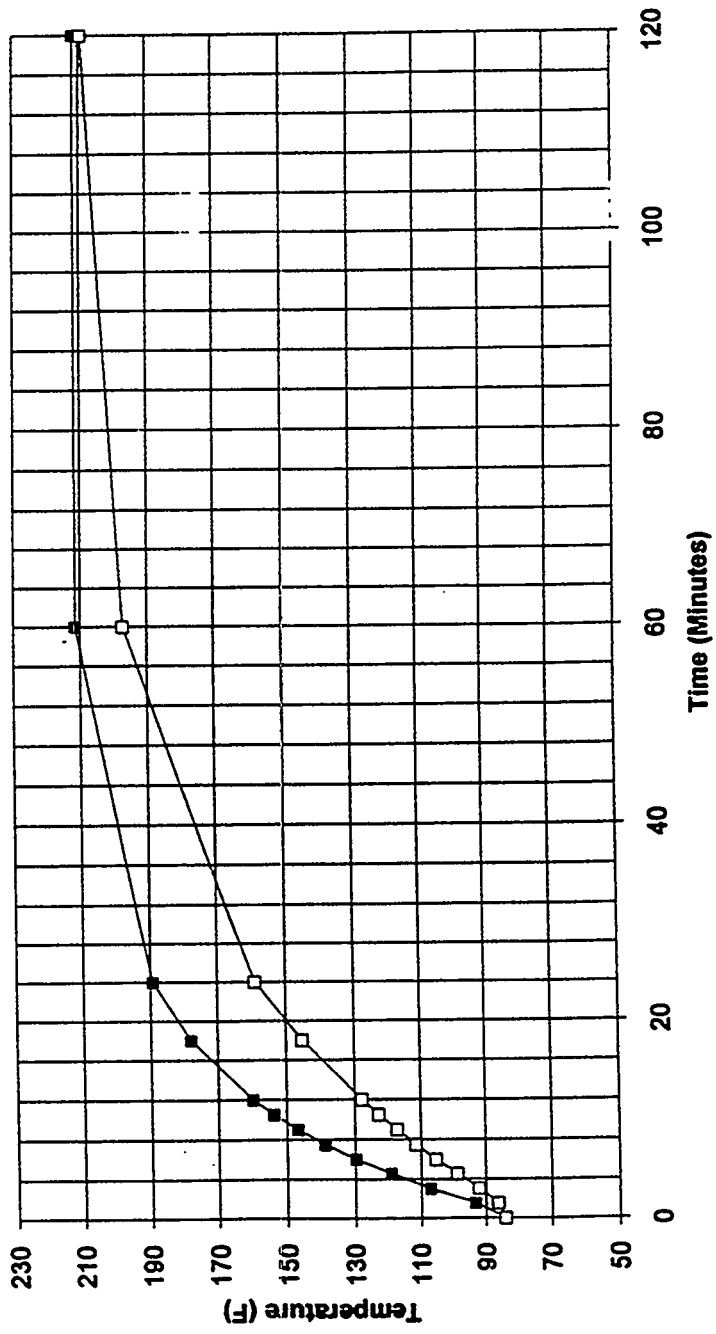

TIME	PRESSURE	PRESSURE	TIME	TEMPERATURE
0.00	50.00	50.00	0.00	84.00
2.17	275.00	465.00	1.50	87.01
4.80	935.00	1085.00	3.00	93.74
8.28	1685.00	1785.00	4.50	99.09
13.21	2485.00	2585.00	6.00	103.84
20.69	3200.00	4200.00	7.50	108.06
			9.00	111.81
			10.50	115.16
			12.00	118.15
			18.00	127.31
			24.00	133.32
			60.00	145.22
			120.00	147.58

VALVE BONNET WATER TEMPERATURE

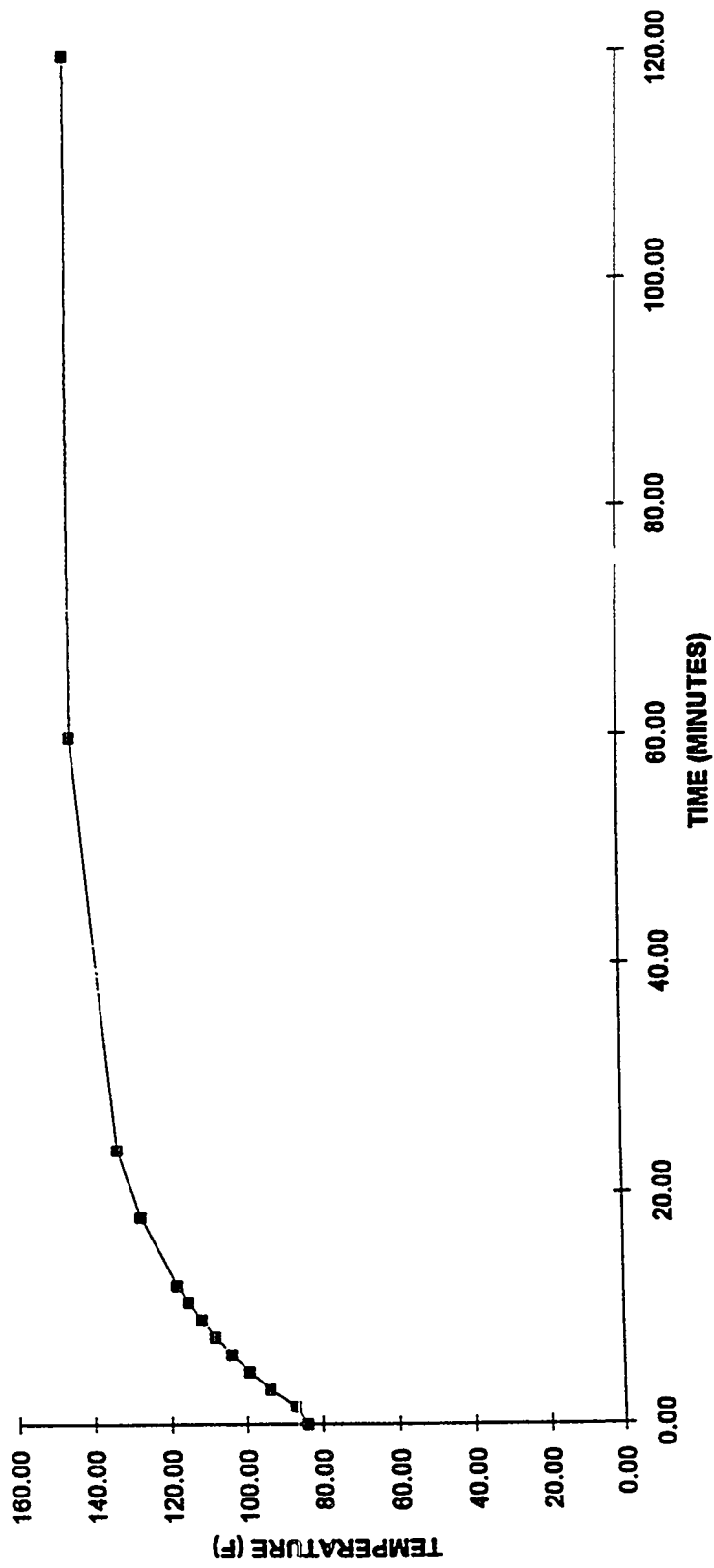

VALVE BONNET WATER PRESSURE

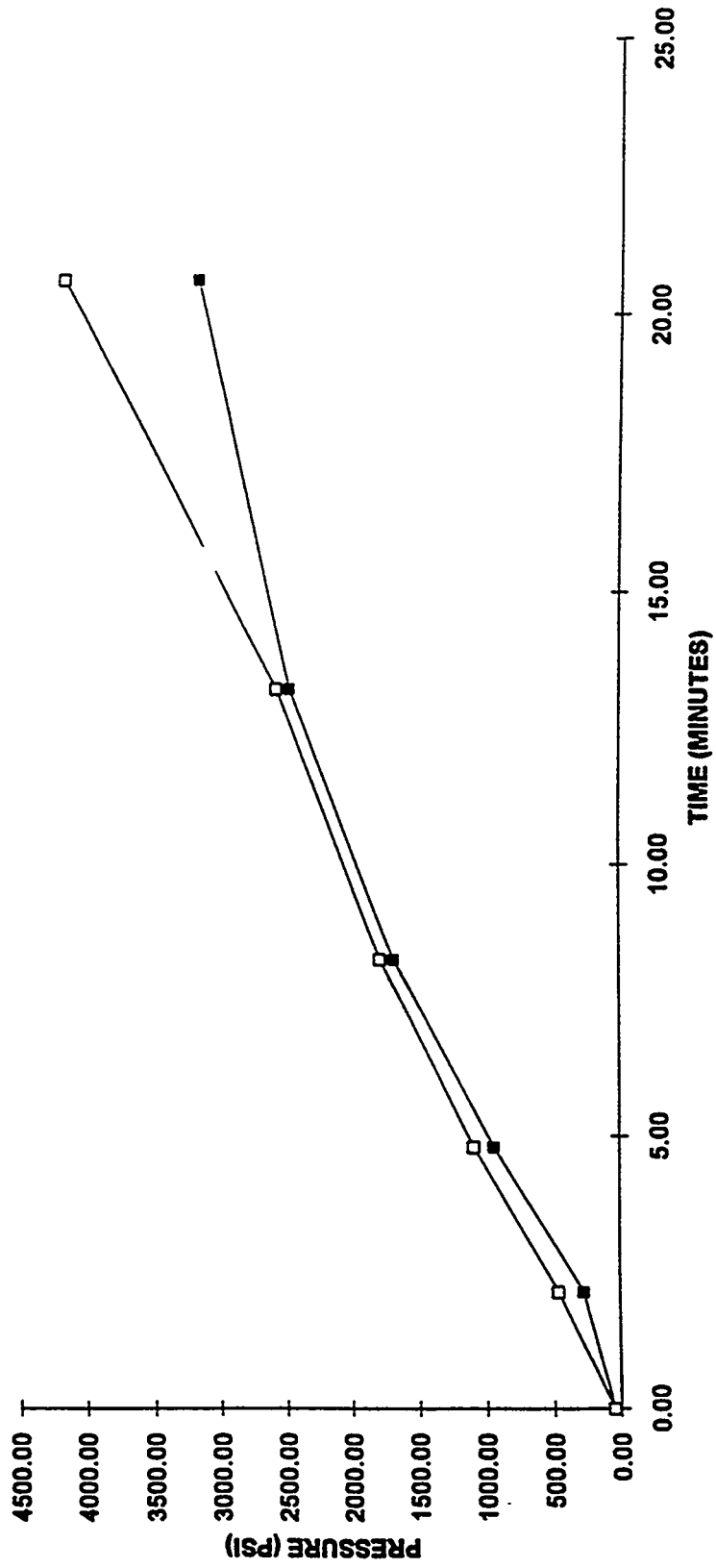

TIME	PRESSURE	PRESSURE	TIME	TEMPERATURE
0.00	50.00	50.00	0.00	84.00
4.32	275.00	465.00	1.50	84.89
9.72	935.00	1085.00	3.00	87.40
16.50	1685.00	1785.00	4.50	90.36
28.28	2485.00	2585.00	6.00	93.31
44.40	3200.00	4200.00	7.50	96.14
			9.00	98.82
			10.50	101.36
			12.00	103.75
			18.00	112.08
			24.00	118.72
			60.00	138.65
			120.00	146.10

VALVE BONNET WATER TEMPERATURE

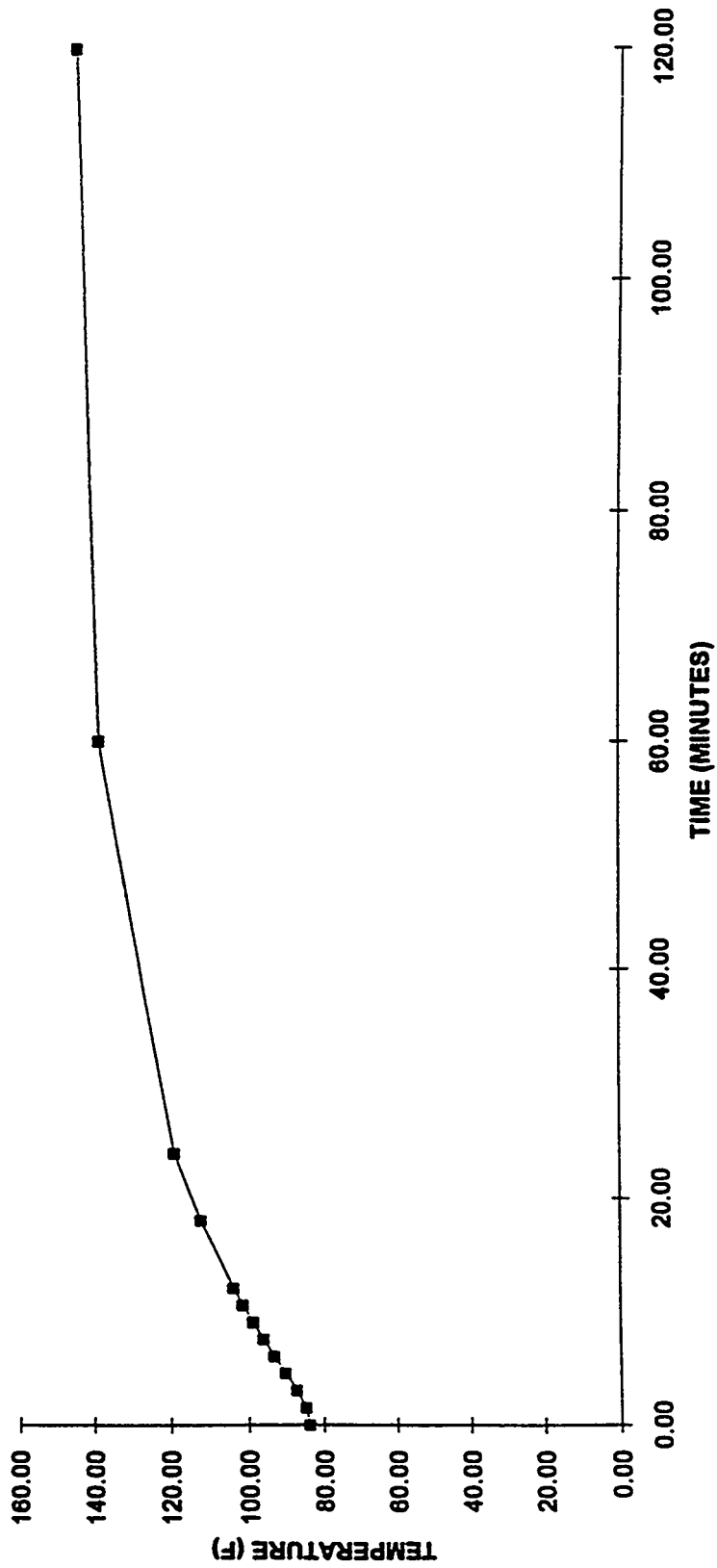

VALVE BONNET WATER PRESSURE

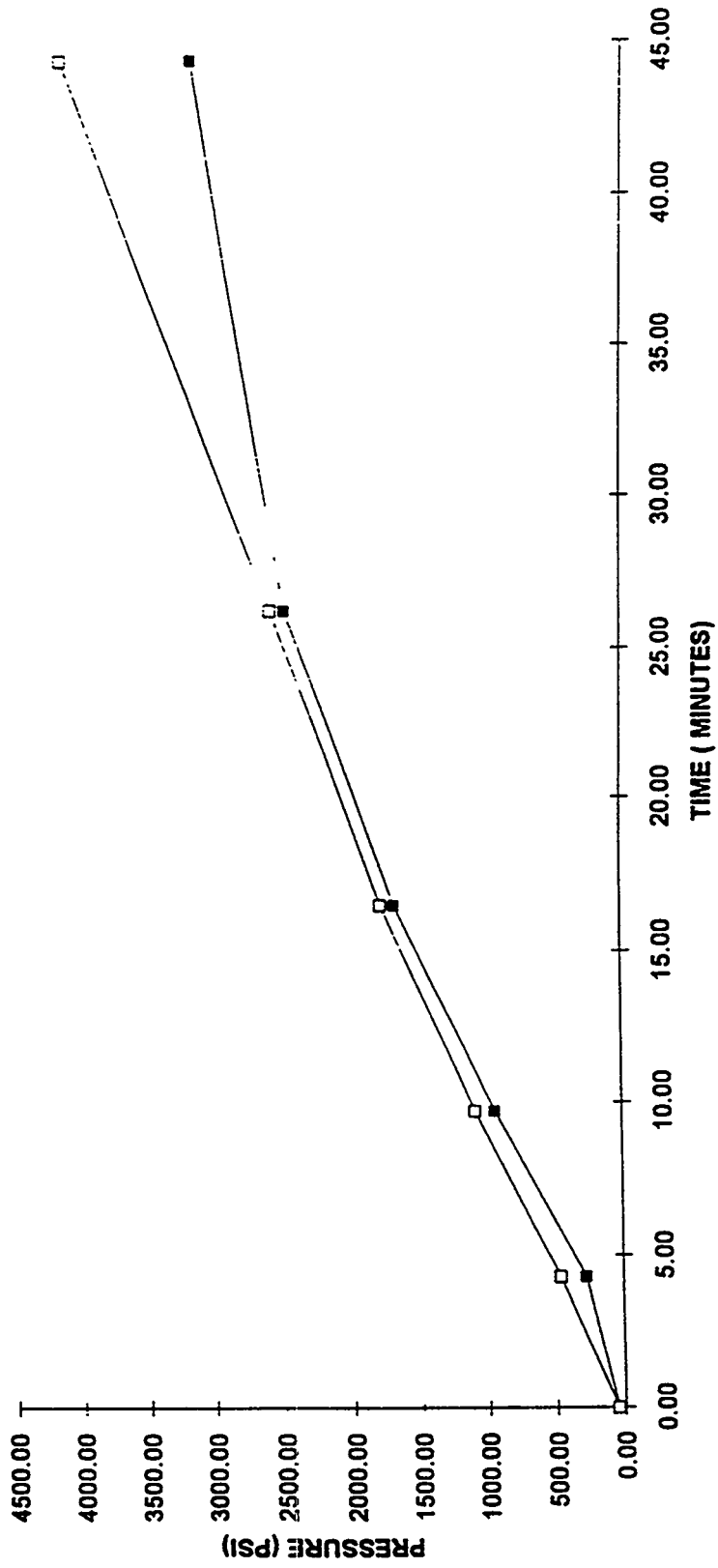

October 22, 1993

Subject: LaSalle County Station, Units 1&2
Potential Binding of 2E12-004B (RHR Valve)

Mr. M. Dowd;

There has been a report that the subject valve may have become thermally bound during certain operating conditions. The valve had to be opened manually. The station engineering group requested the Mechanical & Structural Engineering Design Group review this occurrence and provide an analysis to help determine the root cause.

Our evaluation consisted of two parts. The first part was to perform a two dimensional finite element analysis to determine the thermal growth at the disk-seat interface. This analysis was performed using a two dimensional approach provide a cost effective result. The three dimensional approach would be more accurate but because the data from the occurrence had many assumptions the more detailed approach would not have produced more reliable results. To help expedite the review we employed Primavera Engineers to perform the finite element analysis. This is part of our Minority Engineering Development Program.

The second part of the evaluation was to compare thermal growth with the machining tolerances. We reviewed the lower disk-seat interface where the drawing shows the tolerance to be ± 0.005 inches. The thermal growth in this area is $+0.006$ inches (SRSS). If the valve is -0.000 inches or larger, then there would be a theoretical interference. Typically this would lead to an increased force to open. This comparison shows that under the reported conditions thermal binding is a possibility. To determine the exact cause of the occurrence a detailed analysis and testing under controlled conditions would have to be performed. The valve would also have to be disassembled and detailed as machined measurements would have to be made.

Since the motor operator is planned to be upgraded, a detailed test and analysis program would not be cost effective. Also since the operating practices have been changed to preclude a reoccurrence, there is no additional work planned for the Mechanical & Structural Engineering Design Group.

If you have any questions please contact me on ext. 7685.

Paul Donavin
Mechanical & Structural
Engineering

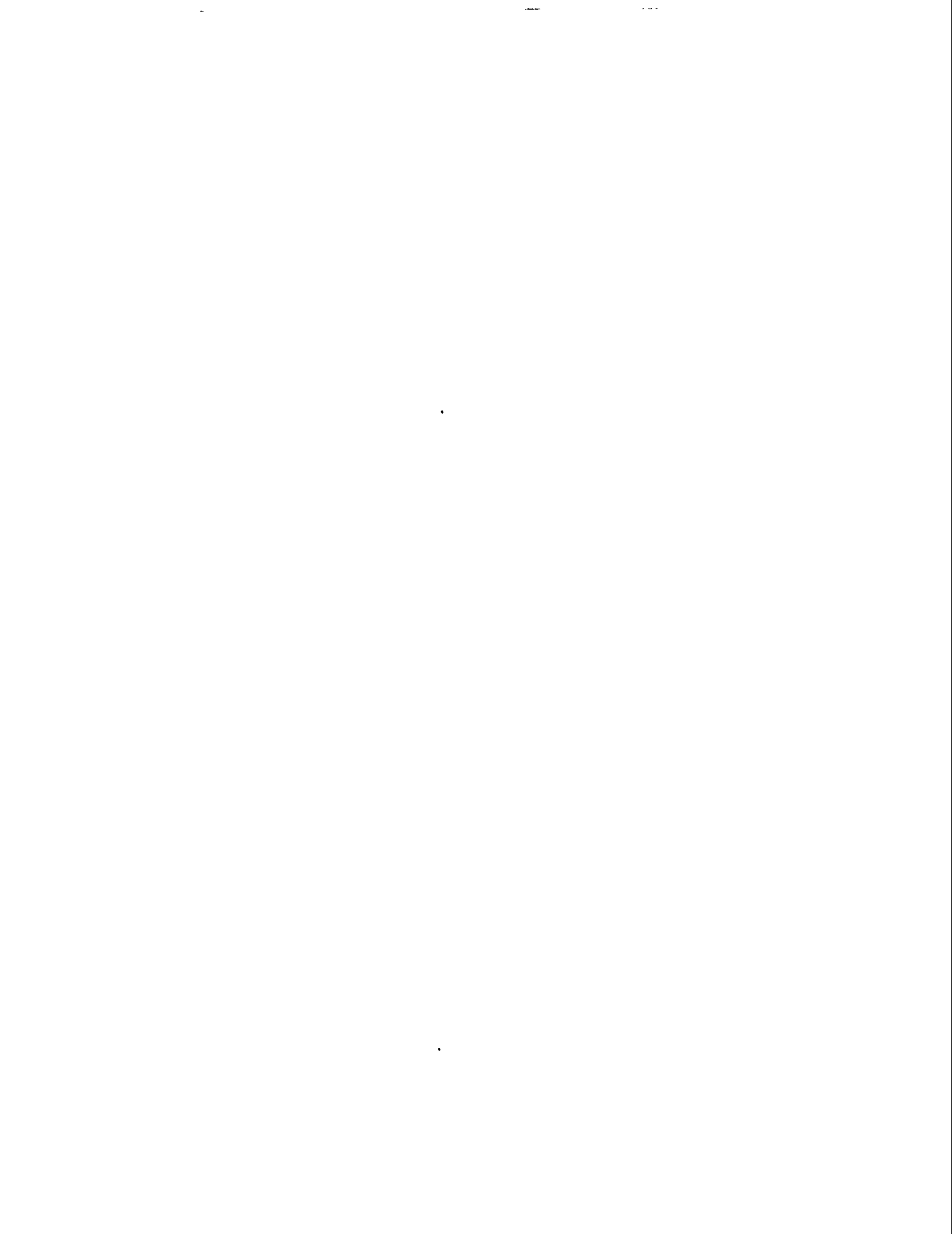

**RHR GATE VALVE
2E12-F004B**

**THERMAL BINDING
ANALYSIS AND REPORT**

**Commonwealth Edison Company
LaSalle County Station**

Prepared By:

Sonja Schillmoeller, 10/13/93

Sonja Schillmoeller

Reviewed By:

Pedro Cevallos-Candau, 10/13/93

Pedro Cevallos-Candau

Table of Contents

	Page
1.0 Cover Page	1
2.0 Table of Contents	2
3.0 Introduction.....	3
3.1 Purpose.....	3
3.2 Background	3
3.3 Project Deliverables	3
4.0 Assumptions.....	3
5.0 Design Input.....	4
6.0 Analysis	4
7.0 Conclusions.....	5
8.0 References	6
Figure 1 - Coordinate System	7
Figure 2 - Nodal Temperatures	8
Figure 3 - Nodal Temperatures	9
Figure 4 - Axisymmetric Thermal Analysis Displacements.....	10
Figure 5 - Axisymmetric Thermal Analysis Stresses.....	11

3.0 **Introduction**

3.1 Purpose

- The purpose of this analysis is to determine whether or not RHR Motor Operated Valve (MOV) 2E12-004B could have experienced thermal binding at an 80 °F temperature differential (160 °F versus 80 °F).

3.2 Background

LaSalle County Station identified a valve that they suspect may have experienced thermal binding and therefore was prevented from opening on certain occasions. The valve was presented to the Mechanical and Structural Engineering Group (MSE) for validation of thermal binding via analysis. Primera was involved in the on-going root problem investigation and subsequently asked to perform a simplified two-dimensional finite element analysis utilizing Algor software.

3.3 Project Deliverables

This report is the only project deliverable. Since the analysis was based on limited design input, a simplified two-dimensional finite element model and the assumptions of Section 4.0, the analysis and this report are not safety related. Therefore, they shall not be used as a design document or as any type of design input.

4.0 **Assumptions**

4.1 The coefficient of linear thermal expansion (α) and the Modulus of Elasticity (E) were held constant.

4.2 After being moved to a closed position, the end of the disc traveled only as far as the ends of the valve body seat rings. In other words, overthrusting of the valve had not occurred (which would have caused the disc to travel past the seat rings and further into the valve body).

4.3 Heat Transfer

- A. The temperature on the upstream side of the valve disc was 160 °F and on the downstream of the valve disc was 80 °F (see Design Input 5.1) .
- B. Heat transfer inside of the piping system was solely a function of conduction..
- C. Conductive heat transfer was limited to one degree of freedom and occurred along the z-axis.
- D. Conductive heat transfer along the z-axis was linear. Therefore, the temperature at the center of the disc was one-half of 160 °F and 80 °F or 120 °F. Temperature profiles are depicted in Figures 2 and 3.

4.4 Finite Element Analysis

- A. Rounded edges of valve components were approximated by corners (straight lines).
- B. A steady-state (or static) as opposed to a transient analysis was performed.

- C. Although water was present inside of the disc, the analysis was modeled using air in this space.
 - D. Component dimensions were taken from Reference 8.2. In addition, some dimensions were scaled.
- 4.5 All valve components were modeled as steel (mild).
- 5.0 **Design Input**
- 5.1 The temperature differential was 80 °F. The temperature upstream of the valve seat was 160 °F and downstream of the valve seat was 80 °F (Reference 8.1).
- 5.2 **Material Properties**
- A. Density (ρ) - 0.2836 lb/in³ Reference 8.3, Page 6-8
 - B. Modulus of Elasticity (E) - 30,000 ksi
 - C. Coefficient of Linear Thermal Expansion (α) - 6.5×10^{-6} in/°F Reference 8.3, Page 6-6
 - D. Poisson's Ratio (ν) - 0.3
- 5.3 A cartesian coordinate system was used and is depicted in Figure 1. The z-axis ran along the centerline of the pipe and the y-axis runs along the centerline of the disc.

6.0 **Analysis**

The valve body seat rings and disc were modeled with a two-dimensional finite element model. To simplify the analysis, half of the disc (from the midpoint of the disc to the valve seat - traveling along the x-axis) was modeled using an axisymmetric model (axis of revolution being the z-axis). Using an axisymmetric model is generally a "stiffer" model. In other words, displacements which are calculated using an axisymmetric model are generally smaller than those that would have been calculated using a more realistic three-dimensional model.

Temperatures at each nodal point, based on Assumption 4.3, were input into the finite element model. The valve body and seat ring (to the edge of the upstream side of the disc) were modeled at a temperature of 160 °F. Likewise, the valve and body seat ring (to the edge of the downstream side of the disc) were modeled at a temperature of 80 °F. Temperatures are more clearly defined in Figures 2 and 3.

The analysis was performed with one fixed point which was located at the origin of the coordinate system. The analysis was then performed to determine displacements and stresses of the valve body, seat rings and disc subjected to the aforementioned temperature distribution.

7.0 Conclusions

The two-dimensional finite element analysis indicated that the MOV, after being subjected to an 80 °F temperature differential across its disc (while the MOV was in a closed position), could have experienced thermal binding. This conclusion was based on the assumptions, design input and analysis delineated in this report as well as the following discussion.

Referring to Figure 4, white lines depict the valve before elevated temperatures are applied and red lines depict the valve after elevated temperatures are applied. From this figure, it is evident that a majority of the nodes experienced displacements along both the y-axis and z-axis. The greatest displacement (using the square of the root of the sums of the squares - SRSS - of the displacements in the y and z direction) was approximately 0.006 inches. Based on minimal contact between the valve body seat and the disc, it could be concluded that thermal binding prevented the valve from opening. In addition, the figure indicates that a bending moment occurred about the x-axis thereby forcing the downstream side of the disc against its seat. It would seem that this force increased the friction between the downstream side of the disc and seat while attempting to open the valve. Referring to Figure 5, it can be seen that the highest stresses are observed at points where the valve seats and disc come into contact. This further enhances the conclusion that the valve could have experienced thermal binding at an 80 °F temperature differential.

The analysis, in Primera's opinion, provides no conclusive evidence that thermal binding occurred. To reach this conclusion, a formal investigation and subsequent three-dimensional analysis should be performed. The investigation should answer the following:

- Was the valve overthrust? How far into the valve seat did the disc travel? When the valve closes, is it limit switch or torque switch controlled?
- What was the actual temperature on the upstream side of the disc? Could the temperature of the pipe contents have been higher than 160 °F (thereby implying that the temperature on the upstream side of the disc was higher than 160 °F)?
- What are the actual dimensions of all valve components?

Furthermore, the analysis should do for the following:

- Determine the temperature distribution, using a three-dimensional finite element analysis, of the entire disc, the valve body seats and the seat rings.
- Model the entire disc and valve body.
- Account for the different types of component materials.
- Determine coefficients of linear thermal expansion and Moduli of Elasticity at actual temperatures and use in the analysis.

8.0 References

- 8.1 LaSalle County Station Problem Identification Form (PIF) dated March 22, 1993, Tracking Number 374-200-93-00444PIF, Primera QA Files**
- 8.2 Anchor Valve Co. Drawing No. 1570-5A, Revision A, 24"-300# Gate Valve R.S. Cast Steel, Stainless Steel Trim B.W. Ends Limitorque Operator, Primera QA Files**
- 8.3 AISC Manual of Steel Construction. Ninth Edition**

Figure 1

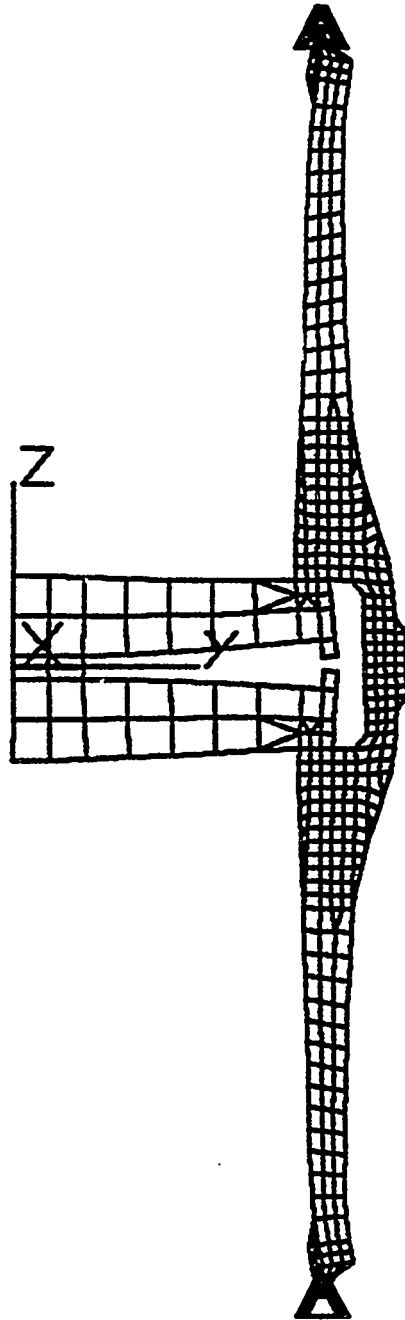

Figure 2

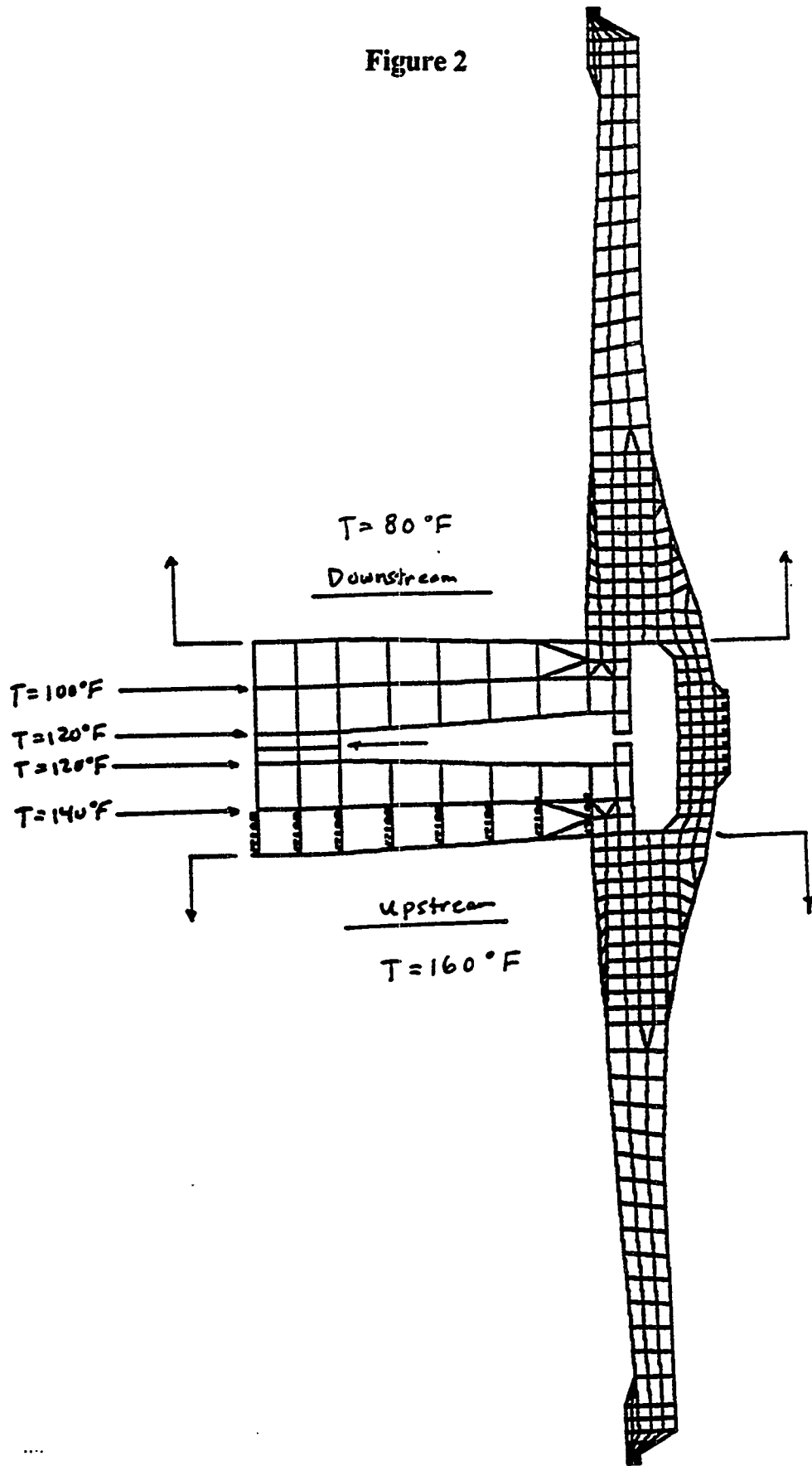
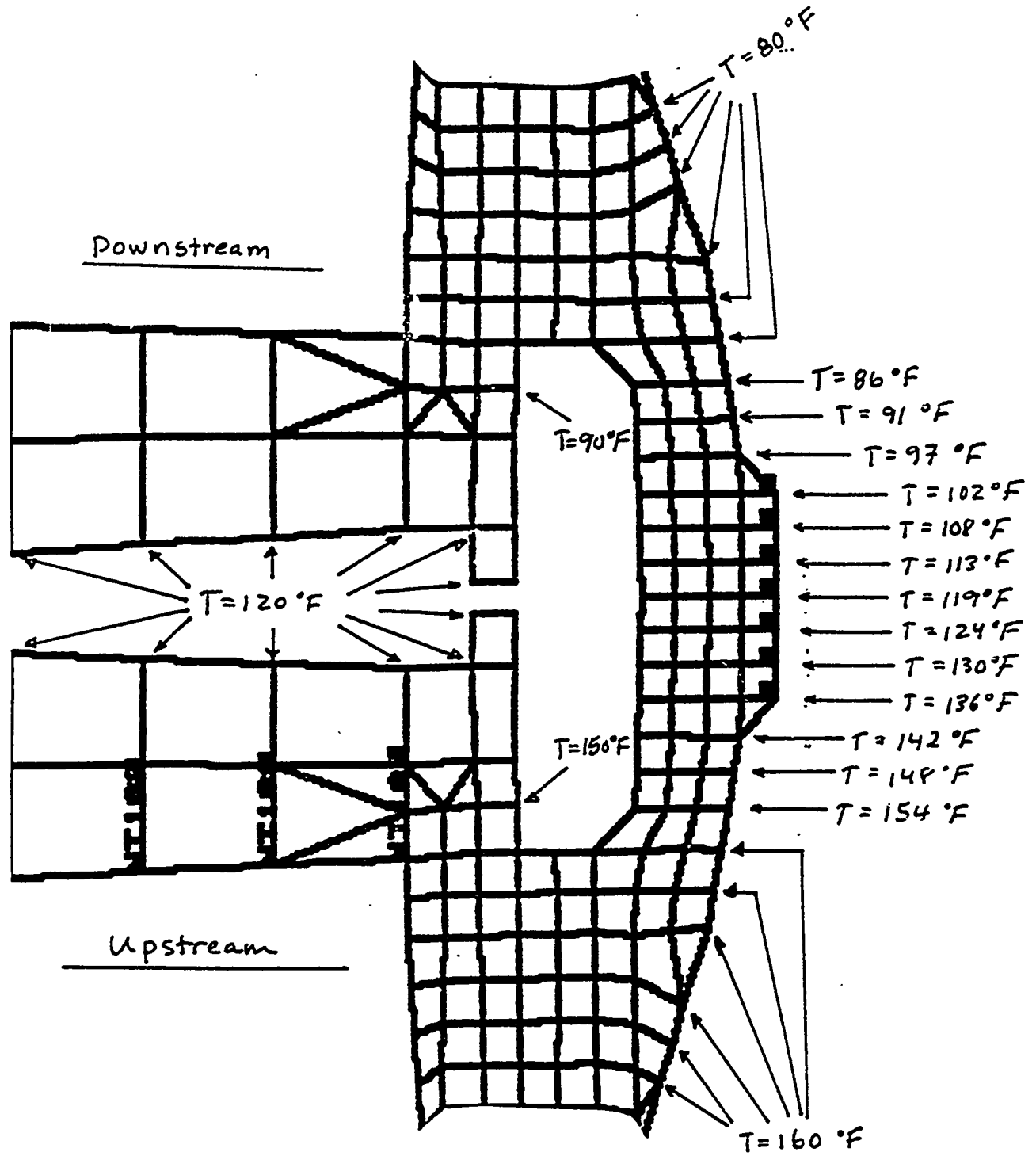

Figure 3



THERMAL BINDING VALVE RESOLUTION

1(2)B21-F016

During an accident or transient the Inboard MSL Drain Inboard Isolation Valve is required to close for its safety function. The EOP's may require it to be reopened to re-establish the Main Condenser as a heat sink. The requirement to re-establish the Main Condenser as a heat sink is a relatively short term action and can be expected to take place within one hour of valve closure. Based on this short time frame the Inboard MSL Drain Inboard Isolation Valve will not have cooled significantly and therefore will not Thermally Bind. If the valve is closed hot during normal unit shutdown and allowed to cool to ambient it could be subject to Thermal Binding however, it would be accessible to plant personnel for compensatory actions. If the valve receives a spurious isolation during normal operation it would be re-opened prior to any significant cooling taking place. This valve has not experienced any Thermal Binding events in 10 years of Dual Unit Operations.

No further action is required on this valve however, if the valve is modified for other reasons in the future replacing it with a Double-Disc gate valve with the Reactor side Disc drilled for bonnet pressure relief should be considered.

1(2)B21-F019

During an accident or transient the Inboard MSL Drain Outboard Isolation Valve is required to close for its safety function. The EOP's may require it to be reopened to re-establish the Main Condenser as a heat sink. The requirement to re-establish the Main Condenser as a heat sink is a relatively short term action and can be expected to take place within one hour of valve closure. Based on this short time frame the Inboard MSL Drain Outboard Isolation Valve will not have cooled significantly and therefore will not Thermally Bind. If the valve is closed hot during normal unit shutdown and allowed to cool to ambient it could be subject to Thermal Binding however, it would be accessible to plant personnel for compensatory actions. If the valve receives a spurious isolation during normal operation it would be re-opened prior to any significant cooling taking place. This valve has not experienced any Thermal Binding events in 10 years of Dual Unit Operations.

No further action is required on this valve however, if the valve is modified for other reasons in the future replacing it with a Double-Disc gate valve with the Reactor side Disc drilled for bonnet pressure relief should be considered.

1(2)E12-F006A/B

The SDC Suction Valves are closed above room temperature on every SDC loop S/D or SDC swap. There has been no Thermal Binding events in over ten years of dual unit operation. The EOP's require SDC be placed into operation during an accident or transient however, if both SDC Suction valves happen to be bound at this point plant personnel can take remedial action locally to open the valves. SDC is not placed on line until the Reactor is less than 135 PSIG and in the recovery phase of the accident or transient. During normal S/U of SDC remedial action can be taken by plant personnel if the SDC suction valves are Thermally Bound.

No further action is required on these valves however, if these valves are modified for other reasons in the future replacing them with a Double-Disc gate valve with the Reactor side Disc drilled for bonnet pressure relief should be considered.

1(2)E12-F008

The SDC Outboard Isolation Valve is closed above room temperature on every SDC loop S/D. There has been no Thermal Binding events in over ten years of dual unit operation. The EOP's require SDC be placed into operation during an accident or transient however, if the SDC Outboard Isolation valve happens to be bound at this point plant personnel can take remedial action locally to open the valves. SDC is not placed on line until the Reactor is less than 135 PSIG and in the recovery phase of the accident or transient. During normal S/U of SDC remedial action can be taken by plant personnel if the SDC Outboard Isolation valve is Thermally Bound.

No further action is required on this valve however, if this valve is modified for other reasons in the future replacing it with a Double-Disc gate valve with the Reactor side Disc drilled for bonnet pressure relief should be considered.

1(2)E12-F009

The SDC inboard isolation valve operator was modified to a larger motor and operator due to previous thermal binding events. The appropriate procedures were also changed to address this problem. There have been no further binding events since replacing the motor operator.

No further action is required on this valve however, if this valve is modified for other reasons in the future replacing it with a Double-Disc gate valve with the Reactor side Disc drilled for bonnet pressure relief should be considered.

HYDRAULIC LOCKING VALVE RESOLUTION

1(2)B21-F016

During an accident or transient the Inboard MSL Drain Inboard Isolation Valve is required to close for its safety function. The EOP's may require it to be re-opened to re-establish the Main Condenser as a heat sink. The requirement to re-establish the Main Condenser as a heat sink is a relatively short term action and can be expected to take place within one hour of valve closure. The Inboard MSL Drain Inboard Isolation Valve will have to cool and condense steam and then re-heat significantly to cause the valve to Hydraulically Lock. Due to the short time frame in which valve re-opening can be expected to occur during an accident this failure mechanism is not probable. If the valve is closed hot during normal unit shutdown and allowed to cool to ambient and re-heat on startup it could be subject to Hydraulic Locking however, it would be accessible to plant personnel for compensatory actions. If the valve receives a spurious isolation during normal operation it would be re-opened prior to any significant cooling taking place.

No further action is required on this valve however, if the valve is modified for other reasons in the future replacing it with a Double-Disc gate valve with the Reactor side Disc drilled for bonnet pressure relief should be considered.

1(2)B21-F019

During an accident or transient the Inboard MSL Drain Outboard Isolation Valve is required to close for its safety function. The EOP's may require it to be re-opened to re-establish the Main Condenser as a heat sink. The requirement to re-establish the Main Condenser as a heat sink is a relatively short term action and can be expected to take place within one hour of valve closure. The Inboard MSL Drain Outboard Isolation Valve will have to cool and condense steam and then re-heat significantly to cause the valve to Hydraulically Lock. Due to the short time frame in which valve re-opening can be expected to occur during an accident this failure mechanism is not probable. If the valve is closed hot during normal unit shutdown and allowed to cool to ambient and re-heat on startup it could be subject to Hydraulic Locking however, it would be accessible to plant personnel for compensatory actions. If the valve receives a spurious isolation during normal operation it would be re-opened prior to any significant cooling taking place.

No further action is required on this valve however, if the valve is modified for other reasons in the future replacing it with a Double-Disc gate valve with the Reactor side Disc drilled for bonnet pressure relief should be considered.

1(2)E12-F009

The SDC inboard isolation valve operator was modified to a larger motor and operator due to previous thermal binding events. The SDC Inboard Isolation Valve is closed above room temperature on every SDC loop S/D. The valve would cool at this point and any water in the bonnet would contract. SDC is normally S/D at a nominal moderator temperature of 150 degf. The SDC suction valves are in EQ zone H2A with a postulated temperature rise of 135 to 330 degf. During normal unit Shutdown this valve has not exhibited any hydraulic locking. During an accident if the valve became hydraulically locked the valve would be opened after the plant had cooled below 135 lbs and the hydraulic lock would have cleared or continued cooldown could be achieved via the SRV's. Since placing Shutdown Cooling on line is a manual operation response time is not a concern and therefore, if the bonnet gets pressurized to Reactor pressure it is unlikely that the valve would be opened until the bonnet pressure had decayed to zero.

No further action is required on this valve, however if this valve is modified for other reasons in the future replacing it with a Double-Disc gate valve with the Reactor side Disc drilled for bonnet pressure relief should be considered.

1(2)E12-F016A/B

The Drywell Spray Valves are closed at normal room temperature. They are required to open during an accident to reduce pressure in the Drywell. The Drywell Spray Valves are in EQ zone H4A with a temperature range of 94 degf to 145 degf based on a High Energy Line Break outside the Drywell and in the Reactor Building. The need to spray the Drywell assumes that there is a line break in the Drywell and the Reactor Building would not heat up to 145 degf. If there is a dual failure and the Reactor Building heats up to 145 degf along with a Drywell pressurization event then the need to open the Drywell spray valves would be required in a relatively short time frame and could be expected to take place in less than one hour. It is unlikely that the Drywell Spray valve would heat up sufficiently in that time frame to become hydraulically locked.

No further action is required on this valve, however if this valve is modified for other reasons in the future a pressure relief modification to the bonnet or valve disc should be considered.

Licensee Experience
Dick Kadlec, American Electric Power Service Corporation

Principal Engineer
Donald C. Cook Nuclear Plant
Columbus, OH

(Enclosure 8)

**RECOGNITION OF AND RESPONSE TO THE POTENTIAL
FOR PRESSURE LOCKING AND THERMAL BINDING
OF GATE VALVES AT THE DONALD C. COOK NUCLEAR PLANT**

**BY: RICHARD A. KADLEC, P.E.
PRINCIPAL ENGINEER
AMERICAN ELECTRIC POWER SERVICE CORPORATION**

Pressure locking and thermal binding of gate valves have been the subjects of several NRC and INPO documents. Pressure locking occurs when the valve bonnet is pressurized from high process fluid pressure and the line pressure subsequently reduces or when a bonnet is pressurized cold and subsequent heat-up increases pressure of fluid trapped in the bonnet above line pressure. In these cases, disc forces on the valve seats become sufficiently high that the valve cannot be opened. Thermal binding results from differential thermal contraction of the parts of a valve which has been closed in the hot condition and then cools, causing the seats to bind the disc so tightly that reopening is impossible until the valve is reheated.

During the original design of the Donald C. Cook Nuclear Plant, the potential for thermal binding of valves in specific locations (services) in safety related systems was recognized. The double disc gate valve design, which is not susceptible to thermal binding, was selected for installation in these locations. The potential for pressure locking of these double disc gate valves was recognized in 1974, the year prior to Unit 1 achieving commercial operation. The phenomenon was a topic of discussion in the EEI Nuclear Task Force. Cook Nuclear Plant management and AEP Service Corporation became aware of it through participation in the Task Force. When the phenomenon was identified as a potential problem, system design and operating procedures were reviewed to ascertain whether any of the double disc gate valves installed at Cook Nuclear Plant were susceptible to hot closure and subsequent cool down. A total of 32 such valves were adjudged susceptible and targeted for modification. The modification consisted of adding an equalizing connection

from the bonnet (or between disc space) to the process pipe for each valve affected. Each equalizing line is equipped with a shutoff valve for maintenance and testing.

The equalizing line option was chosen over drilling a pressure relief hole through the upstream disc since drilling the disc makes the valve unidirectional in sealing. In order to seal, the drilled disc must always be toward the high pressure. By using an equalizing line equipped with shut-off valve, the double disc gate valves' capability to seal in either direction can be restored by closing the shut-off valve as required; e.g., for IST activities.

In 1976, a second design change was initiated to remove the equalizing lines from four valves in one service; viz., the recirculation sump to RHR/CTS pumps suction containment isolation valves. Donald C. Cook Nuclear Plant is an ice condenser containment design. The decision to remove the equalizing lines was based on the low temperatures and pressures associated with the ice condenser containment as related to the opening of these valves. In addition, it was determined that the equalizing lines connected downstream of these valves could provide potential leak paths from containment under certain operating conditions.

In response to INPO SOER 84-07, the issue of pressure locking was revisited, and an investigation of the potential for thermal binding was implemented in 1985. In addition to verifying the conclusions previously reached, the scope of the study addressed any normally closed gate valve installed in a nuclear safety related system. This included auxiliary feed water, essential service water and component cooling water. No candidate valves were identified in these low pressure, low temperature systems. Further efforts were centered around emergency core cooling (RHR and SI) and containment spray systems. To prevent pressure locking, it was decided to add equalizing lines to four valves in one service which had not been previously considered as a candidate for the modification. The investigation of thermal binding was in all cases dispositioned in one of two ways; that the valve being considered was a double disc valve and not susceptible, or in the case of flexible wedge gate valves, that the operating conditions; i.e., no hot closure and subsequent cool down, were not conducive to the phenomenon.

The 1985 study largely corroborated the previous decisions as to which valves required equalizing lines. In the case of the design change initiated to add equalizing lines to one service, the four valves involved were of the flexible wedge design. Previously, only double disc designs had been considered candidates for pressure locking. The 1985 study also revisited the question of whether the recirculation sump to RHR/CTS pumps suction containment isolation valves should be equipped with equalizing connections. It was concluded that the removal of equalizing connections under the design change initiated in 1976 was the correct decision.

Summarizing briefly, the recognition of the potential for thermal binding of gate valves at Cook Nuclear Plant occurred and was dispositioned as part of the plant design. In 1974, prior to commercial service, the phenomenon of pressure locking in double disc gate valves was also recognized and dispositioned. In 1985, in response to INPO SOER 84-07, the entire program was revisited, and only minor additions were made. During the course of investigation, more than 80 valves were evaluated for potential problems with either pressure locking or thermal binding. Of these, 32 were equipped with equalizing connections to prevent pressure locking. No modifications were deemed necessary to preclude thermal binding.

**RECOGNITION OF AND RESPONSE TO THE POTENTIAL
FOR PRESSURE LOCKING AND THERMAL BINDING
AT THE DONALD C. COOK NUCLEAR PLANT**

- **Definition of Phenomena**
- **Recognition of Potential Problems**
- **Chronology of Events**
- **Dispositioning of Issues**

**HISTORY OF
PRESSURE LOCKING/THERMAL BINDING INVESTIGATIONS
AT THE DONALD C. COOK NUCLEAR PLANT**

1974:

- **EEl Nuclear Task Force - Pressure Locking Recognized**
- **Design Change to Add Equalizing Lines to 32 Double Disc Gate Valves**

1976:

- **Design Change to Remove Equalizing Lines from Four Valves**

1984:

- **SOER 84-07 - Pressure Locking and Thermal Binding Addressed**

1985:

- **Reevaluation/Verification of Designs to Consider Pressure Locking**
- **Evaluation of Existing Design to Consider Thermal Binding**
- **Design Change to Add Equalizing Lines to Four Flexible Wedge Gate Valves**

**COOK NUCLEAR PLANT
MOTOR OPERATED GATE VALVES EQUIPPED WITH EQUALIZING LINES**

COMPONENT NO.	FUNCTIONAL NAME/DESCRIPTION
1-IMO-128 2-IMO-128	Reactor Coolant Loop #2 Hot Leg to RHR Pump Suction Shutoff Valve
1-ICM-129 2-ICM-129	Reactor Coolant Loop #2 Hot Leg to RHR Pump Suction Containment Isolation Valve
1-IMO-390 2-IMO-390	Refueling Water Storage Tank to RHR Pump Suction Shutoff Valve
1-IMO-310 2-IMO-310	East RHR Pump Suction Shutoff Valve
1-IMO-320 2-IMO-320	West RHR Pump Suction Shutoff Valve
1-IMO-340 2-IMO-340	East RHR Heat Exchanger Outlet to Charging Pump Suction Shutoff Valve
1-IMO-350 2-IMO-350	West RHR Heat Exchanger Outlet to Charging Pump Suction Shutoff Valve
1-IMO-315 2-IMO-315	East RHR and North SI to Reactor Coolant Loops #1 and #4 Hot Leg Shutoff Valve
1-IMO-325 2-IMO-325	West RHR and South SI to Reactor Coolant Loops #2 and #3 Hot Leg Shutoff Valve
1-IMO-314 2-IMO-314	East RHR Pump Discharge Cross-tie Shutoff Valve
1-IMO-324 2-IMO-324	West RHR Pump Discharge Cross-tie Shutoff Valve
1-IMO-255 2-IMO-255	Boron Injection Tank Train "A" Inlet Shutoff Valve
1-IMO-256 2-IMO-256	Boron Injection Tank Train "B" Inlet Shutoff Valve
1-ICM-250 2-ICM-250	Boron Injection Tank Train "A" Outlet Containment Isolation Valve
1-ICM-251 2-ICM-251	Boron Injection Tank Train "B" Outlet Containment Isolation Valve
1-ICM-260	North SI Pump Discharge Containment Isolation Valve NOTE: Valve 2-ICM-260 design obviates the need for an equalizing line.
1-ICM-265	South SI Pump Discharge Containment Isolation Valve NOTE: Valve 2-ICM-265 design obviates the need for an equalizing line.

SUMMARY

- **Original Design Considered Thermal Binding**
- **1974 Design Change Addressed Pressure Locking**
- **1985 Study in Response to INPO SOER 84-07 Verified Previous Activities**

Licensee Experience
William R. Rowlett, Jr. P.E., Arkansas Nuclear One
James M. Warren, P.E., Gilbert/Commonwealth

Arkansas Nuclear One

(Enclosure 9)

ARKANSAS NUCLEAR ONE

SUMMARY OF THERMAL BINDING AND PRESSURE LOCKING REVIEW PROGRAM AND EFFECT OF SUMP VALVES/INTERLOCKS ON PRESSURE LOCKING

Presented at the 1994 Winter MUG Meeting, New Orleans, Louisiana

William R. Rowlett, Jr., P.E.
Arkansas Nuclear One

James M. Warren, P.E.
Gilbert / Commonwealth

ARKANSAS NUCLEAR ONE

SUMMARY OF THERMAL BINDING AND PRESSURE LOCKING REVIEW PROGRAM AND EFFECT OF SUMP VALVES/INTERLOCKS ON PRESSURE LOCKING

Entergy Operations, Incorporated, operators of the Arkansas Nuclear One (ANO) plant performed a screening review for potential thermal binding and pressure locking of gate valves. This review addressed the locking and binding concerns identified by the United States Nuclear Regulatory Commission's (NRC) report AEOD Special Study S92-07. The special study discusses gate valve failures that prevented safety-related systems from performing their required safety function.

The ANO program reviewed all 181 motor operated, safety related gate valves in the scope of NRC Generic Letter 89 -10 for pressure locking and thermal binding effects. Because of the program reviews, several valves were identified as potentially being susceptible to binding or locking and require further action including more detailed evaluations. ANO's containment sump recirculation valves were noted as having a unique valve and interlock arrangement that made them less susceptible to pressure locking. The following discussion provides an overview of the new program reviews for locking and binding. The program overview discusses the following: scope, approach, results, potential binding and locking resolutions, and program efficiencies. A general discussion of sump valve interlocks is also provided since the basic idea of using interlocks may be a useful technique to prevent pressure locking for other applications. The sump valve interlock discussion provides: a review of the sump valve arrangement, the basis for design arrangement, and the potential benefits of the interlocks in preventing pressure locking.

PROGRAM OVERVIEW

ANO management has set up a proactive program addressing gate valve thermal binding and pressure locking concerns identified in NRC AEOD Special Study S92-07 issued by the NRC Office for Analysis and Evaluation of Operational Data. The NRC issued the AEOD report in NUREG-1275, Volume 9 (March 1993). INPO Significant Operating Experience Report 84-7 also discusses problem gate valves that have failed to open due to disc binding. The objective of the ANO program is to assure all potential locking or binding mechanisms have been addressed. It also will provide readily retrievable records documenting the reviews. Several reviews had been done in the past, but the documentation did not always clearly identify the valves reviewed or the binding / locking issues reviewed. All Unit 1 and Unit 2 motor operated gate valves in the ANO GL 89 - 10 evaluations were included in the new reviews for thermal binding and pressure locking. There is a total of 181 gate valves in this scope. Gilbert / Commonwealth was contracted to perform the reviews.

The work was organized to use existing information as much as possible to improve program efficiency and minimize costs. The first steps were to gather the readily available information and build / import data bases to catalog the information. A significant amount of the initially required information was available from the ANO GL 89 -10 files. The basic data already cataloged included valve size, drawing number, disk type, design/ maximum operating temperatures and pressures. Valve normal and safety positions were also identified. Reviews were done to confirm valve functions, to assure any required functions to open were identified. The valves were then screened to identify valves with a significant (safety related) function to open. As noted in Study S92 - 07, a valve must be closed to be susceptible to locking or binding. A valve must be called on to open after it has been exposed to binding / locking events before it can potentially be a problem.

All 181 valves were initially screened for a required function to open. Sixty-five of the valves were identified as having a required function to open. The entire scope of valves was further reviewed to define valves with high importance to properly function even though they did not serve a direct plant safety function. Nine more valves were identified as needing more detailed reviews. Therefore, a total of 74 valves was evaluated in detail to identify susceptibility to binding / locking.

A separate evaluation was done on each valve for each binding / locking mechanism. Valves performing identical functions, such as opposite train valves, had their evaluations documented on the same evaluation sheet. Evaluations for pressure locking effects were subdivided by into evaluations for hydraulic locking, ambient temperature induced (environmental) boiler effect locking, and branch line induced (proximity) boiler effect locking. The next page is an example summary table from the report showing the initial screening based on the identified function to open.

**APPENDIX 1
ARKANSAS NUCLEAR ONE GL 89 10 GATE VALVE LIST**

FULLTAGNO	TYPE	SIZE	SYSTEM	FUNCTION	NORMAL POSITION	SAFETY DIRECTION	EVAL REQ'D
2CV-1489-1	GATE (SW)	2.00	SW	SW ISO	OPEN	OPEN	N
2CV-1500-1	GATE (SW)	2.00	SW	SW ISO	OPEN	OPEN	N
2CV-1502-2	GATE (SW)	2.00	SW	SW ISO	OPEN*	OPEN	N
2CV-1561-1	GATE (SW)	1.50	SW	SW ISO	OPEN	OPEN	N
2CV-1564-2	GATE (SW)	1.50	SW	SW ISO	OPEN	OPEN	N
2CV-5612-1	GATE (FW)	10.00	BS	RB SPRAY HDR ISO	CLOSED	OPEN	Y
2CV-5613-2	GATE (FW)	10.00	BS	RB SPRAY HDR ISO	CLOSED	OPEN	Y
2CV-5649-1	GATE (FW)	24.00	BS	BS RAS SUC	CLOSED	OPEN	Y
2CV-5650-2	GATE (FW)	24.00	BS	BS RAS SUC	CLOSED	OPEN	Y
CV-1616	GATE (SD)	4.00	BS	NAOH ISO	CLOSED	OPEN	Y
CV-1617	GATE (SD)	4.00	BS	NAOH ISO	CLOSED	OPEN	Y
2CV-4916-2	GATE (SW)	3.00	CVCS	2P39 DISCH	CLOSED	OPEN	Y
2CV-4920-1	GATE (SW)	3.00	CVCS	BA TO HP5I	CLOSED	OPEN	Y



Hydraulic locking occurs when a flexible wedge or double disc gate valve in the closed position has higher pressure fluid trapped in the bonnet compared to the system pressure. One scenario leading to this type of binding occurs when the valve is closed with the system at high pressure followed by a decrease in the system pressure. The higher pressure fluid trapped in the bonnet will force both sides of the disc against the seats, causing the disc-seat friction forces to resist valve reopening. Boiler effect locking occurs when a closed gate valve with liquid trapped in the bonnet cavity is subjected to an external temperature increase. The bonnet fluid will try to expand due to the temperature increase. If the valve bonnet is leak tight, the fluid cannot expand so the pressure in the bonnet increases. The resultant pressurization of the bonnet cavity may prevent the valve from opening. Small temperature increases of the bonnet fluid in short periods of time, can potentially cause binding. The temperature increase may be a result of proximity to another heat source, or from environmental air temperature increases. Temperature increases from either of these effects may heat the trapped bonnet liquid and cause locking. Additionally, if a gas (or steam) system valve is installed with a horizontal or below horizontal stem orientation, condensate liquid may collect in the valve bonnet. If a valve in this configuration is subsequently closed and is subjected to an external temperature increase, the resultant pressurization may prevent the valve from reopening. Proximity boiler effect is due to heat conduction through the piping from a hot adjacent branch line. Environmental boiler effect is due to air temperature increases due to plant events such as a LOCA.

Accident ambient conditions potentially affect the fluid if they elevate the area temperature around a closed valve for a significant period before the valve must open. Valves that are required to open within minutes of an accident would not be affected by the elevated ambient conditions, as described on the evaluation sheets. Accident scenarios which peak at temperatures below 140° are considered mild environments, matching the approach used by Equipment Qualification methodology. This cutoff is considered conservative because the methods of calculating ambient temperature in the nuclear industry have historically been very conservative.

The scenarios described above were addressed during the evaluation of each valve. Several other factors were also accounted for. For example, thermal binding concerns were eliminated for valves with double discs (parallel disc) since they are not susceptible to thermal binding. Many sources of information were researched to define the detailed operating parameters and prevailing conditions when the valve is closed.

Below are several examples of sources researched:

- Piping And Instrumentation Diagrams
- Piping Layout Drawings
- Valve Drawings
- Operating Mode Calculations
- Pipe Line Specifications
- Differential Pressure Calculations
- Thrust Calculations
- Environmental Temperature Calculations
- Operating Procedures
- Abnormal Operating Procedures
- Emergency Procedures
- Maintenance Procedures
- System Training Manuals
- Design Basis Documents (Upper Level)
- Safety Analysis Report
- Technical Specifications

The following pages are an example of a valve review.

1. Valve ID: 2CV-0716-1		EFW Suction from SW Header #1	
2. System:	SW	5. Service: For service information see calcs 91-E-0091-01 R0 (Unit 1) 91-E-0091-02 R0 (Unit 2)	
3. Valve Size:	6.000		
4. Vlv/Disk Type:	GATE (FW)		

6. Evaluation

Thermal Binding

This valve is not subject to thermal binding as the maximum process fluid temperature is 123° (Ref. 6).

Hydraulic Locking

This valve is not subject to hydraulic locking as the maximum trapped pressure from EFW normal operations is less than the SW pressure which is present when system switchover is required. Ref. 6 states that the operator is sized to accommodate full shutoff head of the SW pump.

Environmental Boiler Effect

This valve is not subject to environmental boiler effect as the maximum ambient environmental temperature is 140° (Ref. 3).

(cont'd next slide)



1. Valve ID: 2CV-0716-1		EFW Suction from SW Header #1	
2. System:	SW	5. Service:	
3. Valve Size:	6.000	For service information see calcs	
4. Vlv/Disk Type:	GATE (FW)	91-E-0091-01 R0 (Unit 1)	
		91-E-0091-02 R0 (Unit 2)	

Proximity Boiler Effect

This valve is not subject to proximity boiler effect locking as it is in a cold system with no heat sources (Ref. 4,5,6).

7. Recommendations and Conclusions:

This valve is acceptable as-is for performance of it's safety functions.

8. References:

1. 91-E-0091-01 R0
2. 91-E-0091-02 R0
3. NES 13 R0
4. 2HBC-85-1 / 25
5. M2204, SH4, G2 / 51
6. V-2099-00 / 0

(cont'd from previous slide)



Forty-one valves were identified as potentially susceptible to binding / locking. These valves require further action, including a more refined evaluation of the events potentially causing the binding / locking. The number of valves per system requiring further action are listed below:

- 12 Decay Heat / Shutdown Cooling
- 10 Emergency Feedwater
- 6 Main Steam
- 4 Reactor Coolant
- 2 Service Water
- 1 Chemical And Volume Control

A summary of the types of potential concerns requiring further review is:

- Thermal Binding = 18
- Pressure Locking = 28
- Hydraulic Locking = 23
- Environmental Boiler = 6
- Proximity Boiler = 4

The total is not 41 because some valves are susceptible to more than one type of binding / locking.

Some examples of potential concerns requiring further action are:

- Hydraulic locking for decay heat "drop leg" and injection
- Proximity boiler effect at the decay heat / BWST suction
- Thermal binding due to steam back leakage through the EFW injection valves

Examples of potential corrective actions are:

- Implement procedural changes
- Perform calculation changes
- Incorporate interlocks
- Monitor piping and valve temperatures
- Perform detailed heat transfer calculations for piping
- Develop environmental temperature profiles
- Evaluate pump start-up time versus valve opening time
- Evaluate emergency power loading sequence
- Use SB actuators or spring packs
- Perform field tests
- Use PRA to decide if event is credible
- Revise regulatory commitments
- Modify valves
- Change to different type valve

The success of this and similar evaluation programs is highly dependent on clearly defining the valve functions and the operating parameters and prevailing conditions

when the valve is closed. Participation from Operations personnel is very important to achieve the proper level of valve function definition. Operations involvement also enhances implementation of required resolution actions since they are made aware of the potential issues and consequences. Program efficiencies can be significantly enhanced if electronic copies of the plant operating and emergency procedures are available to speed up the search for required valve functions. Use of existing GL 89 - 10 information and the proper marriage of data bases for quick sorting of parameters such as disk type also significantly improve efficiency in the evaluations. Last, clearly documenting the valves evaluated and the types of binding / locking evaluated is essential to program success.

EFFECT OF SUMP VALVE INTERLOCKS ON PRESSURE LOCKING

Mitigating Pressure Locking Effects on PWR sump recirculation valves with valve sequencing.

Pressurized Water Reactors that use Residual or Decay Heat (RHR) pumps as Low Pressure Injection (LPI)Pumps may be subject to pressure locking of the Reactor Building Sump Recirculation valves by the Reactor Coolant System Fluid (RCS) during the RHR mode of operation.

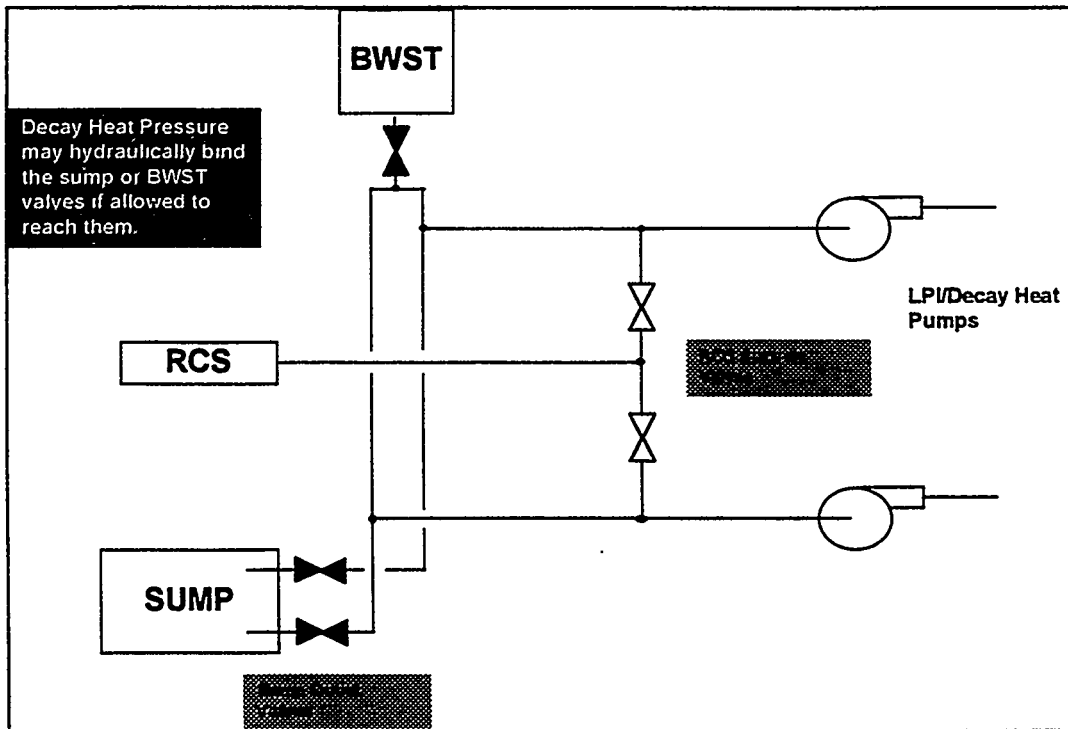

Figure 1 - Typical PWR valve arrangement

During the time that the RHR system is operational, RCS fluid at typical RHR pressures of >200 psig is in direct contact with the outer sump recirculation valves. The sump valves are usually gate valves designed to open against low differential pressures. Pressure from the RCS may force fluid into the bonnets, hydraulically binding flex wedge and double disc type valves. Should the sump valves be later required to operate during an accident requiring fluid recirculation from the sump, they may fail to open.

Borated Water Storage Tank (BWST) outlet valves are usually protected by check valves. However, should the check valves leak, the BWST valves could also bind under similar circumstances.

The addition of two valves to the LPI BWST suction lines can alleviate hydraulic locking concerns to the sump valves. The valves must be designed to open against RHR System pressure and can be interlocked with the RHR RCS suction valves.

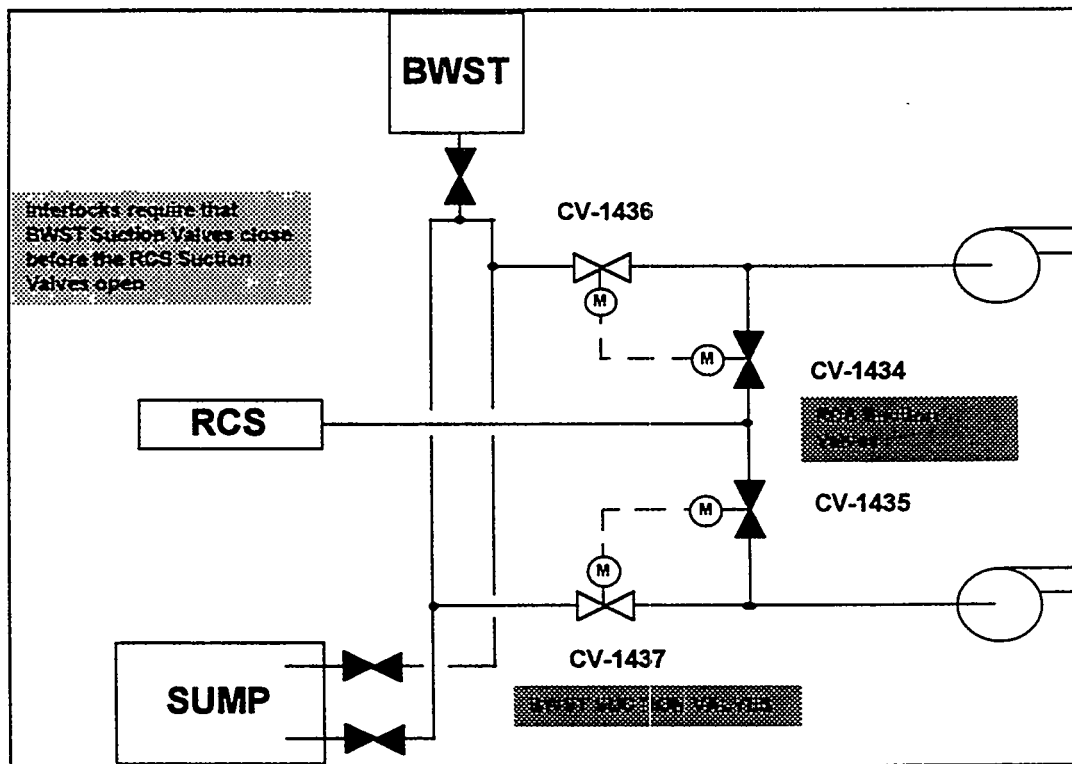

Figure 2 - Valve/Interlock arrangement

In aligning to the RHR mode, the BWST suction valves are closed before the RHR Suction valves open. This prevents RHR system pressure from reaching the sump outlet valves.

When the RHR system is to be secured and the pumps realigned to the BWST for Emergency Safeguards operation, the RCS Suction valves are closed before the BWST valves are opened. Again, this prevents high pressure RHR fluid from binding the sump outlet valves.

Many PWR plants currently have this valve configuration in place to protect the low pressure BWST piping from the higher pressure RCS fluid during the RHR mode. Administrative controls are usually in place to properly sequence the valves. The addition of interlocks can further enhance the ability of the valves to protect the sump valves from becoming pressure locked. In some plants, including ANO-1, the interlocks allow the opening of the BWST suction valves with key switches once the RCS suction valves are open. This allows gravity draining to the sump for boron precipitation mitigation. Even so, the interlocks still provide some degree of assurance against pressure locking the sump valves.

Because the sump outlet valves are containment isolation valves, physical modifications to prevent pressure locking are not usually desirable. Plants may wish to investigate using valve configuration and interlock logic similar to this to protect their sump valves from becoming pressure locked.

ARKANSAS NUCLEAR ONE

- PROGRAM SUMMARY
 - JIM WARREN OF GILBERT / COMMONWEALTH
- SUMP VALVE INTERLOCKS
 - BILL ROWLETT OF ARKANSAS NUCLEAR ONE

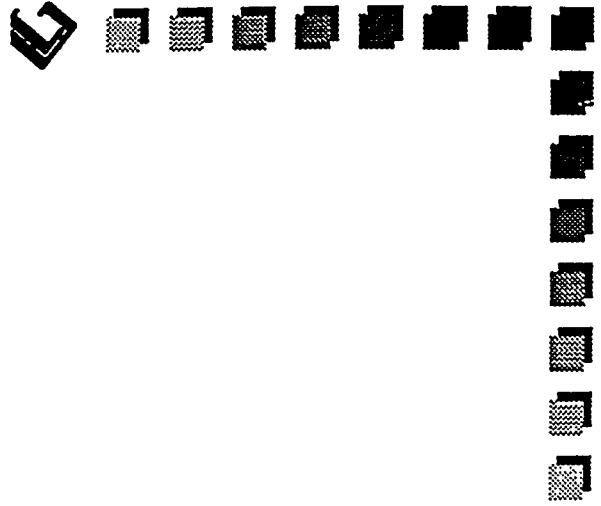

AGENDA

- JIM WARREN
 - SCOPE
 - APPROACH
 - RESULTS
 - POTENTIAL RESOLUTIONS
 - PROGRAM EFFICIENCIES
- BILL ROWLETT
 - BACKGROUND
 - BASIS FOR DESIGN
 - BENEFITS FOR PREVENTING PRESSURE LOCKING

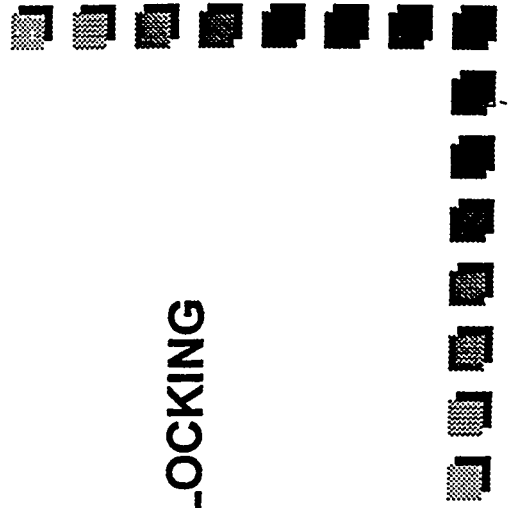

SCOPE

- PROACTIVE PROGRAM ADDRESSING AEOD
SPECIAL STUDY S92-07
- OBJECTIVE
 - TO ASSURE ALL LOCKING METHODS ADDRESSED
 - IMPROVE DOCUMENTATION
- SCOPE = ALL 181 IE 89 - 10 GATE VALVES



WORK FLOW CHART

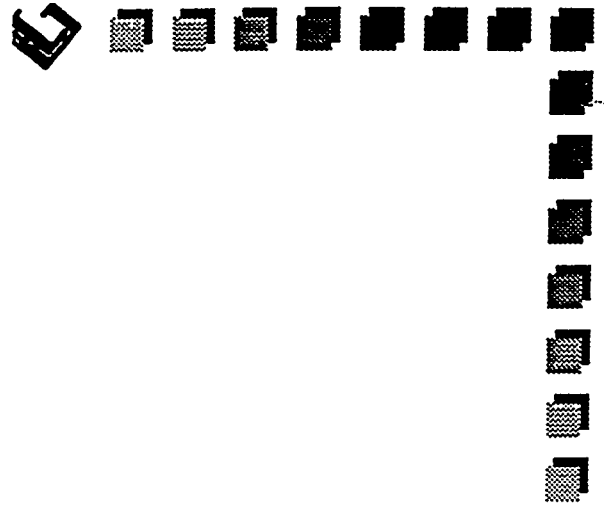
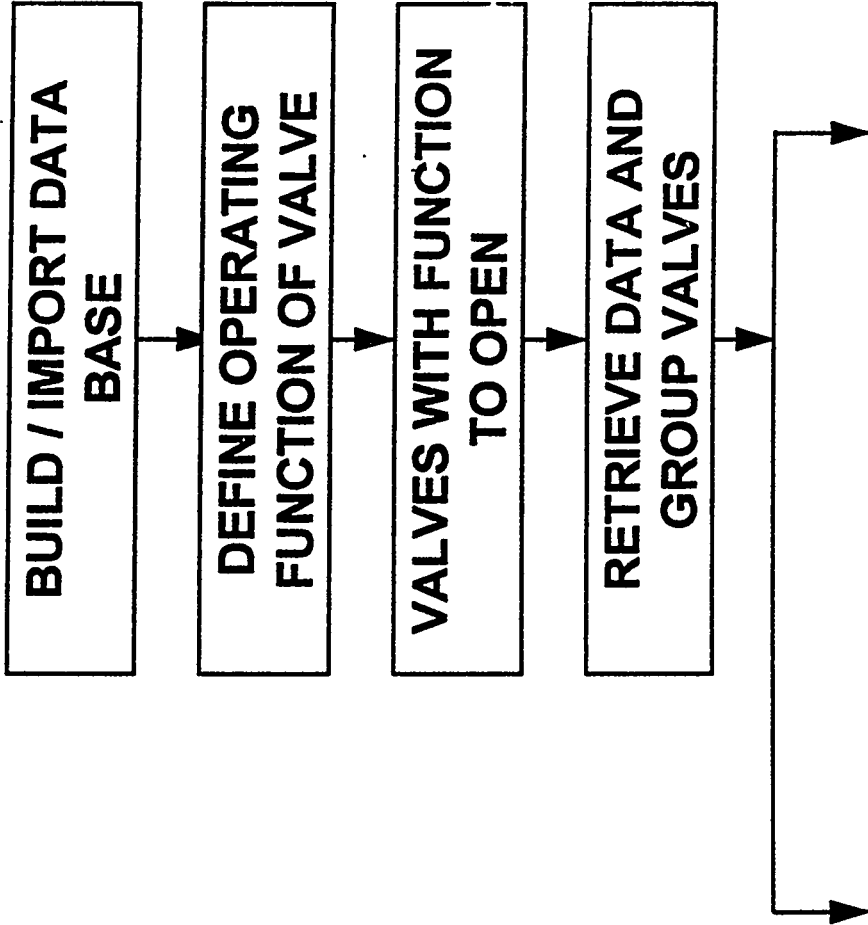

**APPENDIX 1
ARKANSAS NUCLEAR ONE GL 89 10 GATE VALVE LIST**

JLLTAGNO	TYPE	SIZE	SYSTEM	FUNCTION	NORMAL POSITION	SAFETY DIRECTION	EVAL REQ'D
CV-1489-1	GATE (SW)	2.00	SW	SW ISO	OPEN	OPEN	N
CV-1500-1	GATE (SW)	2.00	SW	SW ISO	OPEN	OPEN	N
CV-1502-2	GATE (SW)	2.00	SW	SW ISO	OPEN*	OPEN	N
CV-1561-1	GATE (SW)	1.50	SW	SW ISO	OPEN	OPEN	N
CV-1564-2	GATE (SW)	1.50	SW	SW ISO	OPEN	OPEN	N
CV-5612-1	GATE (FW)	10.00	BS	RB SPRAY HDR ISO	CLOSED	OPEN	Y
CV-5613-2	GATE (FW)	10.00	BS	RB SPRAY HDR ISO	CLOSED	OPEN	Y
CV-5649-1	GATE (FW)	24.00	BS	BS RAS SUC	CLOSED	OPEN	Y
CV-5650-2	GATE (FW)	24.00	BS	BS RAS SUC	CLOSED	OPEN	Y
V-1616	GATE (SD)	4.00	BS	NAOH ISO	CLOSED	OPEN	Y
V-1617	GATE (SD)	4.00	BS	NAOH ISO	CLOSED	OPEN	Y
CV-4916-2	GATE (SW)	3.00	CVCS	2P39 DISCH	CLOSED	OPEN	Y
CV-4920-1	GATE (SW)	3.00	CVCS	BA TO HPSI	CLOSED	OPEN	Y



VALVES REVIEWED

- 181 VALVES REVIEWED
- 65 VALVES WITH FUNCTION TO OPEN
- 9 VALVES ADDED DUE TO IMPORTANCE
- 74 VALVES WITH DETAILED EVALUATIONS





SOURCES RESEARCHED

- PIPING AND INSTRUMENTATION DIAGRAMS
- PIPING LAYOUT DRAWINGS
- VALVE DRAWINGS
- OPERATING MODE CALCULATIONS
- PIPE LINE SPECIFICATIONS
- DIFFERENTIAL PRESSURE CALCULATIONS
- THRUST CALCULATIONS
- ENVIRONMENTAL TEMPERATURE CALCULATIONS



SOURCES RESEARCHED CONTINUED

- OPERATING PROCEDURES
- ABNORMAL OPERATING PROCEDURES
- EMERGENCY PROCEDURES
- MAINTENANCE PROCEDURES
- SYSTEM TRAINING MANUALS
- DESIGN BASIS DOCUMENTS (UPPER LEVEL)
- SAFETY ANALYSIS REPORT
- TECHNICAL SPECIFICATIONS

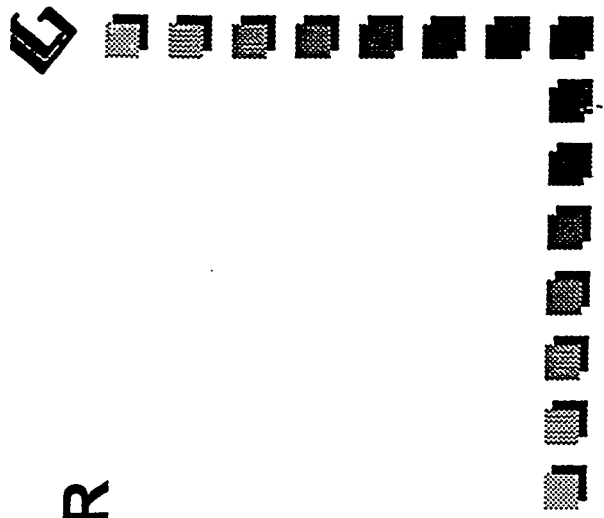

WORK FLOW CHART 2

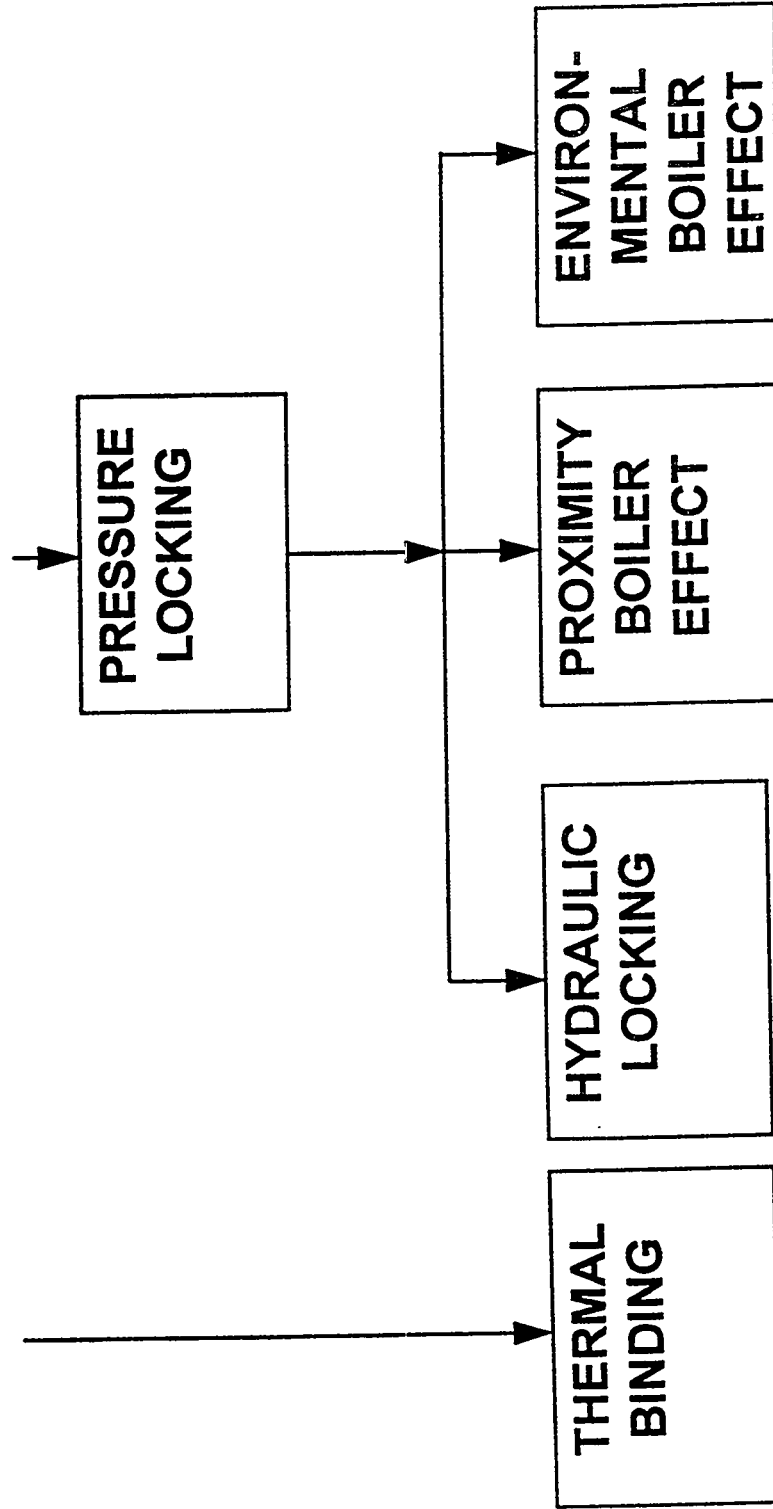

1. Valve ID: 2CV-0716-1		EFW Suction from SW Header #1	
2. System:	SW	5. Service: For service information see calcs 91-E-0091-01 R0 (Unit 1) 91-E-0091-02 R0 (Unit 2)	
3. Valve Size:	6.000		
4. Viv/Disk Type:	GATE (FW)		

6. Evaluation

Thermal Binding

This valve is not subject to thermal binding as the maximum process fluid temperature is 123° (Ref. 6).

Hydraulic Locking

This valve is not subject to hydraulic locking as the maximum trapped pressure from EFW normal operations is less than the SW pressure which is present when system switchover is required. Ref. 6 states that the operator is sized to accommodate full shutoff head of the SW pump.

Environmental Boiler Effect

This valve is not subject to environmental boiler effect as the maximum ambient environmental temperature is 140° (Ref. 3).

(cont'd next slide)



1. Valve ID: 2CV-0716-1		EFW Suction from SW Header #1	
2. System:	SW	5. Service:	
3. Valve Size:	6.000	For service information see calcs 91-E-0091-01 R0 (Unit 1) 91-E-0091-02 R0 (Unit 2)	
4. Vlv/Disk Type:	GATE (FW)		

Proximity Boiler Effect

This valve is not subject to proximity boiler effect locking as it is in a cold system with no heat sources (Ref. 4,5,6).

7. Recommendations and Conclusions:

This valve is acceptable as-is for performance of it's safety functions.

- 8. References:**
1. 91-E-0091-01 R0
 2. 91-E-0091-02 R0
 3. NES 13 R0
 4. 2HBC-85-1 / 25
 5. M2204, SH4, G2 / 51
 6. V-2099-00 / 0

(cont'd from previous slide)



RESULTS 1

- 41 VALVES REQUIRING FURTHER ACTION
 - 12 DECAY HEAT / SHUTDOWN COOLING
 - 10 EMERGENCY FEEDWATER
 - 6 MAIN STEAM
 - 4 REACTOR COOLANT
 - 2 SERVICE WATER
 - 1 CHEMICAL AND VOLUME CONTROL

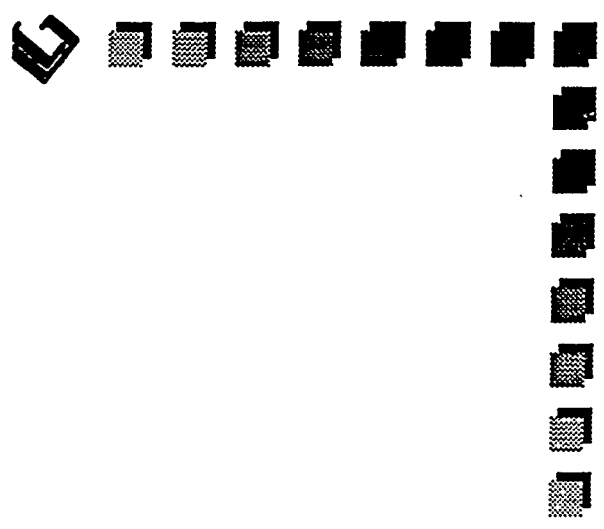

RESULTS 2

- THERMAL BINDING = 18
- PRESSURE LOCKING = 28
 - HYDRAULIC LOCKING = 23
 - ENVIRONMENTAL BOILER = 6
 - PROXIMITY BOILER = 4

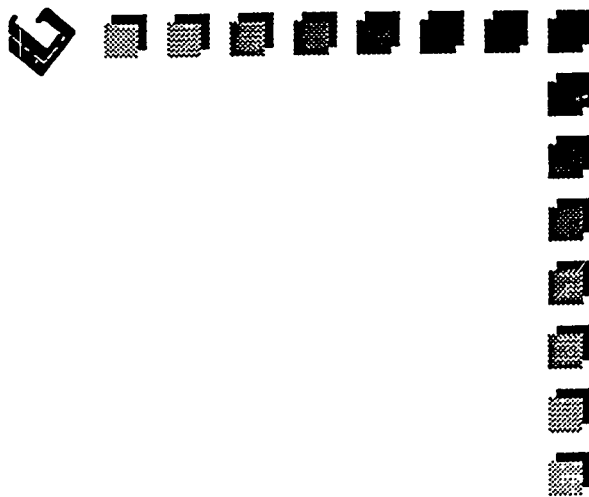

EXAMPLES OF ITEMS NEEDING FURTHER REVIEW

- HYDRAULIC LOCKING FOR DECAY HEAT
"DROP LEG" AND INJECTION
- BORON DILUTION MODE FOR DECAY HEAT
- PROXIMITY BOILER EFFECT AT THE
DECAY HEAT / BWST SUCTION
- THERMAL BINDING FOR STEAM BACK
LEAKAGE THROUGH THE EFW INJECTION
VALVES



POTENTIAL CORRECTIVE ACTIONS

- PROCEDURAL CHANGES
- CALCULATION CHANGES
- INCORPORATE INTERLOCKS
- MONITORING PIPING AND VALVE TEMPERATURES
- DETAIL HEAT TRANSFER CALCULATIONS FOR PIPING
- DEVELOPING ENVIRONMENTAL TEMPERATURE PROFILES
- PUMP STARTUP TIME VERSUS VALVE OPENING TIME

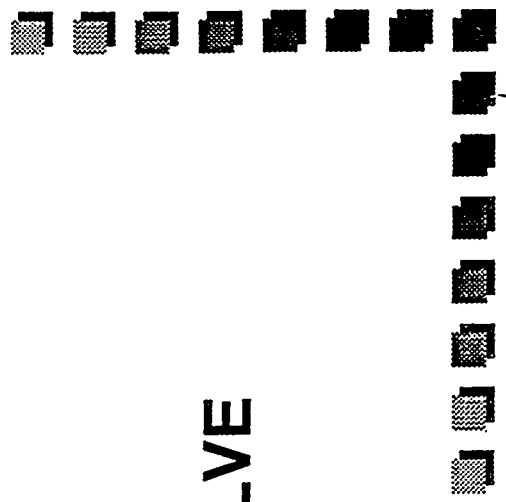

POTENTIAL CORRECTIVE ACTION CONTINUED

- EVALUATION OF EMERGENCY POWER
LOADING SEQUENCE
- USE SB ACTUATORS OR SPRING PACKS
- FIELD TESTS
- USE PRA TO DETERMINE IF EVENT IS
CREDIBLE
- REVISE REGULATORY COMMITMENTS
- MODIFY VALVES
- CHANGE TO DIFFERENT TYPE VALVE



EFFICIENT IMPLEMENTATION

- WORK SMART - 5 HOURS PER VALVE
- ELECTRONIC COPIES OF PROCEDURES AVAILABLE
- VALVE FUNCTIONS WELL DEFINED
- OPERATIONS INVOLVEMENTS IN PROGRAM
- DETAILED VALVE REVIEWS FOR EACH LOCKING MECHANISM
- CLEAR DOCUMENTATION
- NRC SUPPORT WHEN CORRECTIVE ACTION RECOMMENDED



**MITIGATING PRESSURE
LOCKING EFFECTS ON PWR
SUMP RECIRCULATION VALVES
WITH VALVE SEQUENCING**



Typical RHR/LPI Diagram

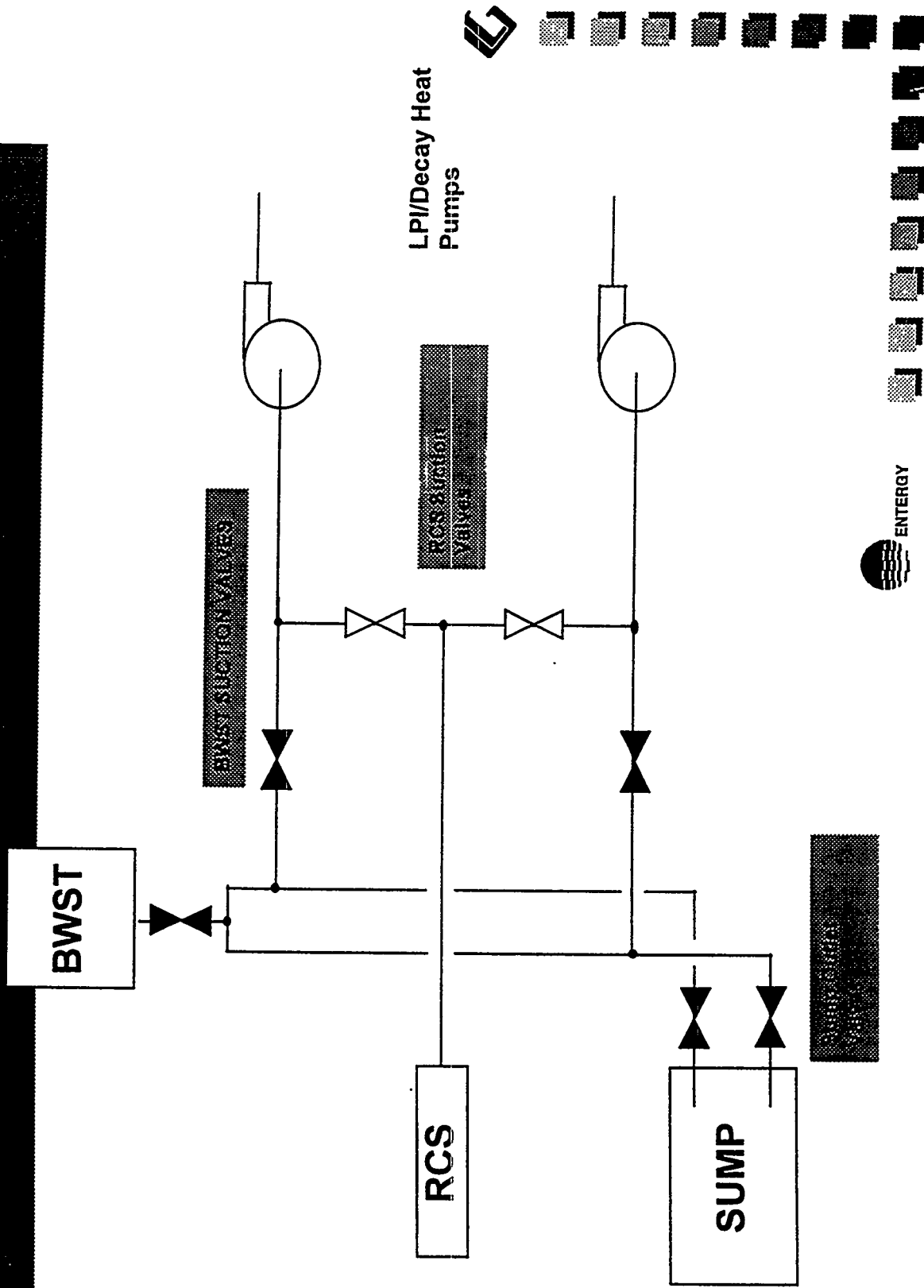

RHR / DECAY HEAT SYSTEM MODES AT ANO - 1

- DECAY HEAT REMOVAL
- ENGINEERING SAFEGUARDS
- BORON CONCENTRATION ELIMINATION
POST - LOCA



DECAY HEAT REMOVAL MODE

- BWST VALVE CLOSED FOR PIPING ISOLATION FROM DECAY HEAT
- DECAY HEAT REMOVAL SUCTION VALVES OPEN TO PUMPS FOR COOLING

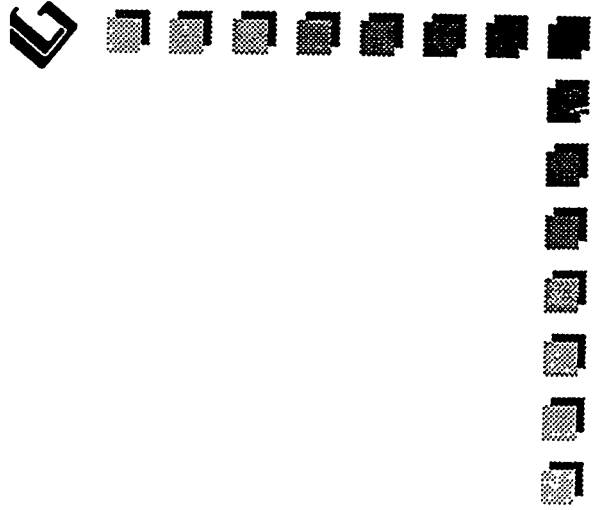

ENGINEERING SAFEGUARDS

MODE

- RCS SUCTION VALVES CLOSED FOR RCS ISOLATION FROM BWST PIPING
- BWST SUCTION VALVE OPEN TO PUMP FOR INJECTION



BORON DILUTION MODE

- **ONE ALTERNATIVE USES DECAY HEAT SUCTION ALIGNMENT**
- **ALARA REQUIRED ADDITION OF VALVE MOTOR OPERATORS**
- **VALVE INTERLOCKS ALSO ADDED**



Simplified RHR/LPI Diagram

Engineered Safeguards Alignment at ANO-1

Interlocks require that BWST Suction Valves close before the RCS Suction Valves open

BWST

CV-1436

CV-1434

RCS Suction Valves

CV-1435

CV-1437

BWST Suction Valves

RCS

SUMP

LPI/Decay Heat Pumps



Simplified RHR/LPI Diagram

RHR/Decay Heat Alignment at ANO-1

Decay Heat Pressure may hydraulically bind the sump or BWST valves if allowed to reach them.

BWST

CV-1436

CV-1434

RCS

CV-1435

CV-1437

SUMP

RCS SUCTION VALVES

BWST SUCTION VALVES

LPI/Decay Heat Pumps

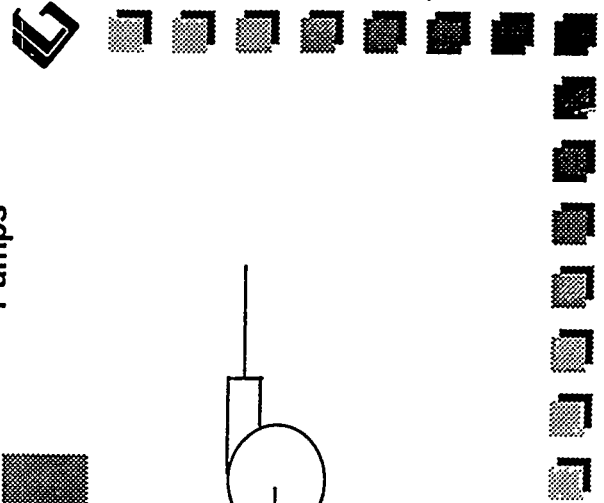

VALVE / INTERLOCK BENEFITS

- DECAY HEAT PIPING DESIGN PRESSURE = 300 PSIG
- BWST SUPPLY / SUMP PIPING DESIGN PRESSURE = 70 PSIG
- ISOLATION OF LOW / HIGH PRESSURE PIPING
- INTERLOCKS ASSURE DECAY HEAT SUCTION VALVES CLOSE BEFORE BWST VALVE OPEN THUS PREVENTING HYDRAULIC LOCKING
- APPROACH CAN BE USED AT OTHER LOCATIONS



Vendor Actions
Ike Ezekoye, Westinghouse Electric Corporation

Fellow Engineer
Westinghouse Nuclear Technology Division
Pittsburgh, PA

(Enclosure 10)

PRESSURE LOCKING AND THERMAL BINDING IN GATE VALVES: WESTINGHOUSE EXPERIENCE

by

Ike Ezekoye

Fellow Engineer

Westinghouse Nuclear Technology Division

Pittsburgh, PA

ABSTRACT

The potential for gate valves to pressure lock and thermal bind exists in gate valves. In this presentation, the pre-production qualification program Westinghouse undertook to reduce the potential for thermal binding is covered.

The essential features of the valve qualification program are two fold: (a) establish limiting nozzle loads through test that will not be deleterious to the valves, and (b) evaluate the effects of thermal cycles (i.e, heatups and cooldowns) on valve operating loads. It is cautioned that the thermal cycling test was not performed to confirm valve operating loads. Rather it was done to isolate the effects of heatups and cooldowns on valve performance. While, no specific pressure locking testing was performed, the presentation covers means for mitigating pressure locking which Westinghouse has employed on request from utilities. The advantages and disadvantages of each scheme are discussed.

Insight gained from our experience suggests that the problems of pressure locking and thermal binding linger because there is limited coordination of activities between the valve designer, the plant constructor and the utility. Areas where each of these groups can play some role are identified.

PRESENTATION OVERVIEW

The presentation focuses primarily on Westinghouse Gate valves. The Westinghouse gate valve line was developed in the early 1970's to meet strict Nuclear Steam Supply System requirements such as low leakage, seismic loads, nozzle loads and thermal transients). The valves are forged stainless steel gates and hence are very robust by design. To confirm whether or not the design met the structural and functional requirements, an extensive valve qualification testing was undertaken. Two of the tests performed, which are considered relevant to thermal binding, are: nozzle load evaluation and hot/cold cyclic testing. Table 1 outlines the hot/cold test matrix. The test results confirmed that the operability of our valve is not affected by nozzle loads defined by our specifications and valve opening load is affected when a hot seated valve is cooled at a rate of 100°F/hr. No tests were performed to simulate pressure locking.

Two cases of field failures are presented. One covers a pressure locking event and the other covers a thermal binding event. Four corrective measures for pressure locking (drilling a hole in the disc or in the body, installing an equalizer, and installing a relief valve) are illustrated. Their advantages and disadvantages are presented in Table 2. In Table 3, areas where the valve manufacturer, the plant constructor and the plant operator can work on to minimize the incidents of pressure locking and thermal binding are discussed.

**PRESSURE LOCKING
AND THERMAL BINDING
IN
GATE VALVES:
WESTINGHOUSE EXPERIENCE**

**Presented at NRC Sponsored
Public Workshop on Pressure Locking/Thermal Binding**

**New Orleans, LA
February 4, 1994**

by

**Ike Ezekoye
Fellow Engineer
Westinghouse Nuclear Technology Division
Pittsburgh, PA**

01/0001/0001/0001/0001

PRESENTATION PLAN

- ☛ REVIEW WESTINGHOUSE GATE VALVE DESIGN
- ☛ REVIEW WESTINGHOUSE PRE-PRODUCTION VALVE QUALIFICATION TESTING
- ☛ OVERVIEW OF FIELD EXPERIENCE WITH PRESSURE LOCKING/THERMAL BINDING
- ☛ SHOW EXAMPLES OF VALVE MODIFICATIONS PERFORMED
- ☛ DISCUSS INSIGHTS GAINED
- ☛ QUESTIONS

WESTINGHOUSE GATE VALVE DESIGN

BACKGROUND

- ▶ Decision to make gates and checks for nuclear service circa 1970
- ▶ Limit the valves to stainless steel
- ▶ Meet rigorous NSSS requirements:
 - ★ Tight Seat Leakage (0 - 3 cc/hr/in)
 - ★ Pipe Nozzle Loads
 - ★ Seismic Loads
 - ★ Natural Frequency Requirement of 33 Hz.
 - ★ Thermal transients
 - ★ Reliability/Maintainability

DESIGN FEATURES OF THE GATE VALVE

- ▶ Massive Forged body/bonnet/disc
- ▶ Articulated Linkage
- ▶ Wide seating surfaces

r:\acelabare\lic\arctalk

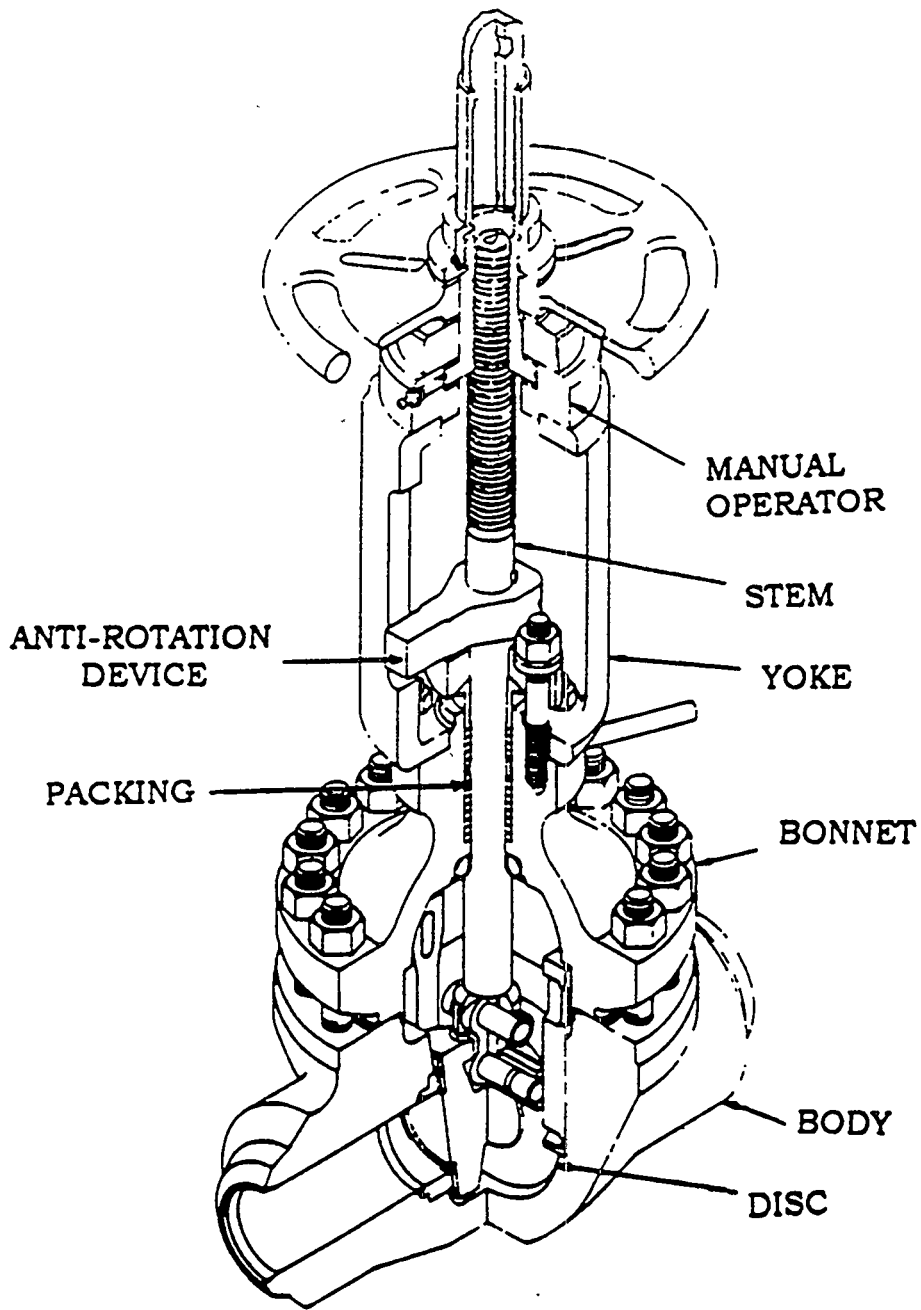

WESTINGHOUSE GATE VALVE DESIGN

PRE-PRODUCTION VALVE QUALIFICATION

☛ STANDARD VENDOR QUALIFICATION ACTIVITIES

- ▶ Flow Test: Line Resistance (L/D), etc
- ▶ Shell Test
- ▶ Leakage Test
- ▶ Load Characterization

☛ ADDITIONAL TESTING

- ▶ Natural Frequency
- ▶ Seismic Operability Test
- ▶ Nozzle Loads
- ▶ Thermal Cycling

r:\aoc\labrel\ie\arctalk

PRE-PRODUCTION VALVE QUALIFICATION

☛ PRESSURE LOCKING/THERMAL BINDING CONSIDERATIONS

- ▶ Pressure Locking (Limited Control)
 - ★ Temperature dependent phenomenon
 - ★ Operationally induced during mode changes

- ▶ Thermal Binding (Substantial Control)
 - ★ Nozzle Load
 - ★ Thermal transients

NOZZLE LOAD TEST

OBJECTIVE:

Evaluate the effects of pipe end loads on valve operability

NOZZLE LOAD LIMITS:

MAX PRINCIPAL STRESS $\leq .75$ YIELD (PIPE)

MAX BENDING $\leq .5$ YIELD (PIPE)

MAX TORSION $\leq .5$ YIELD (PIPE)

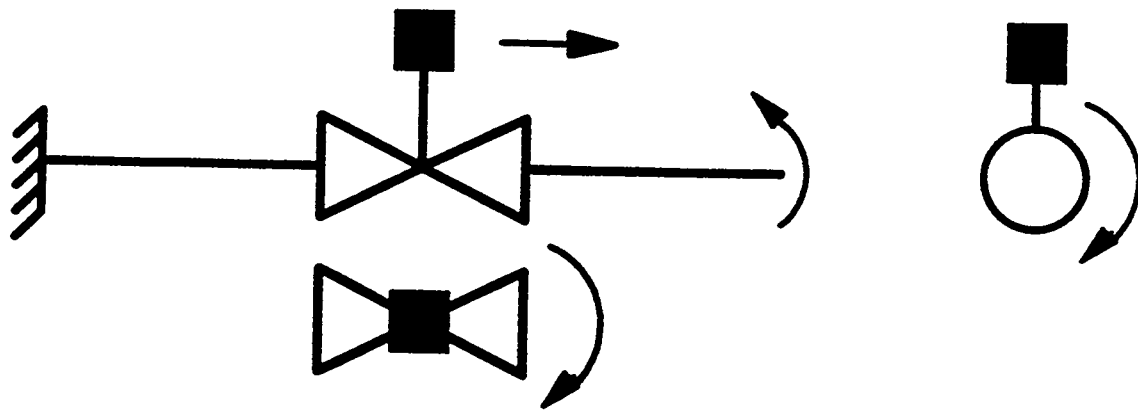

Figure Showing Nozzle and Seismic Load Testing

RESULTS:

NO EFFECT ON LEAKAGE

NO EFFECT ON OPERATING LOADS

NO EFFECT ON STROKE TIMES

COLD-HOT CYCLE TEST

OBJECTIVE:

To verify the performance of the valves under simulated actual conditions to uncover design weaknesses for improvement

RESULTS:

HOT SEATING FOLLOWED WITH COOLDOWN
INCREASES OPENING LOAD
HOT BACK SEATING FOLLOWED WITH COOLDOWN
REDUCES INITIAL UNSEATING LOAD

NUREG/CP-0146

Table 1

Westinghouse Cold and Hot Cycle Valve Qualification Test Matrix
(Not Including Endurance Test)

Test	Type	Cycle	Pressure/Temperature	Measurements	Objective
1	Cold	Valve Closed	500 psi - 3400 psig at room temperature	bonnet stress disc stress seat leakage	Characterize the loads and stresses due to delta P's
2	Hydro	Valve Closed	4000 - 6425 psig at room temperature	bonnet stress stem stress	Evaluate the effect of hydro- test pressure on valve body stresses
3	Hot	50 cycles in 10 hours	2200 psig at 620°F 150 gpm Heatup/Cooldown 100°F	stem load	Monitor stem load cooldown closed and reopened
4	Hot	50 cycles in 10 hours	2200 psig at 620°F 150 gpm Heatup/Cooldown 100°F	stem load	Monitor stem load cooldown open and reclosed

Valve stroke time 10 secs.

FIELD EXPERIENCE

- ☛ LIMITED: FEW DATA GETTING BACK TO US
- ☛ PRESSURE LOCKING CASE

8 INCH 300 CLASS
TEMP. WENT FROM 100°F TO 300°F

VALVE FAILED TO OPEN
SOLUTION: DRILL HOLE IN THE DISC

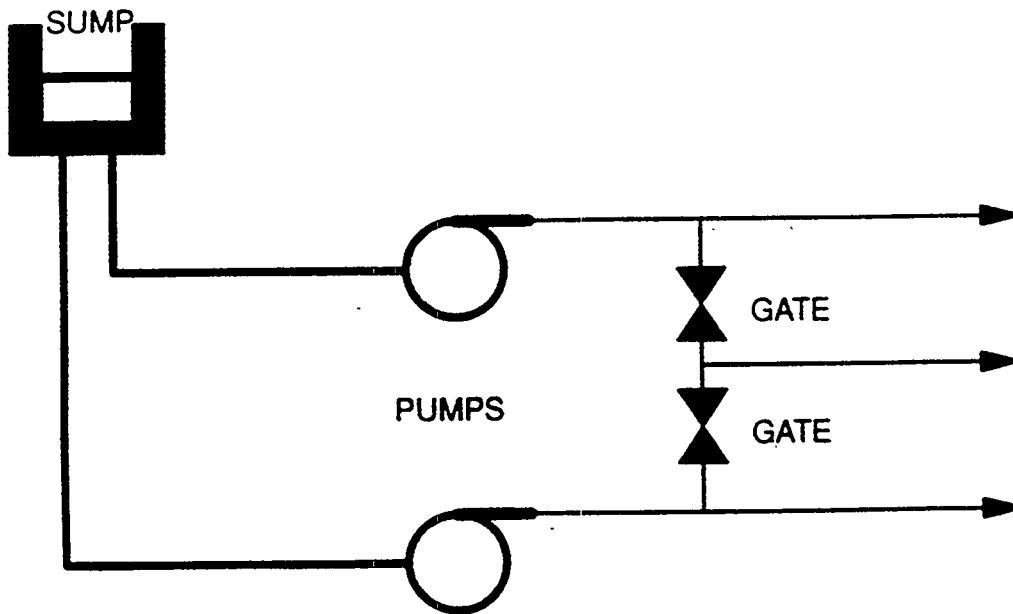

Figure Showing the Location of Pressure Locked Gate Valves

THERMAL BINDING CASE

8 INCH 300 CLASS
VALVE INITIALLY HOT
SHOCKED WITH COLD WATER AS IT WAS
CLOSING

SIGNALS TO OPEN: IMMEDIATE AFTER
CLOSURE - OPENS

30 MIN. AFTER CLOSURE - FAILS TO OPEN
2 HOURS AFTER CLOSURE - OPENS

SUSPECT THERMAL BINDING AND THE PROBLEM
IS UNRESOLVED

NUREG/CP-0146

EXAMPLES OF FIELD MODIFICATIONS ON WESTINGHOUSE VALVES

© 1988 by Westinghouse Electric Corporation

FIGURE SHOWING DISK DRILLING

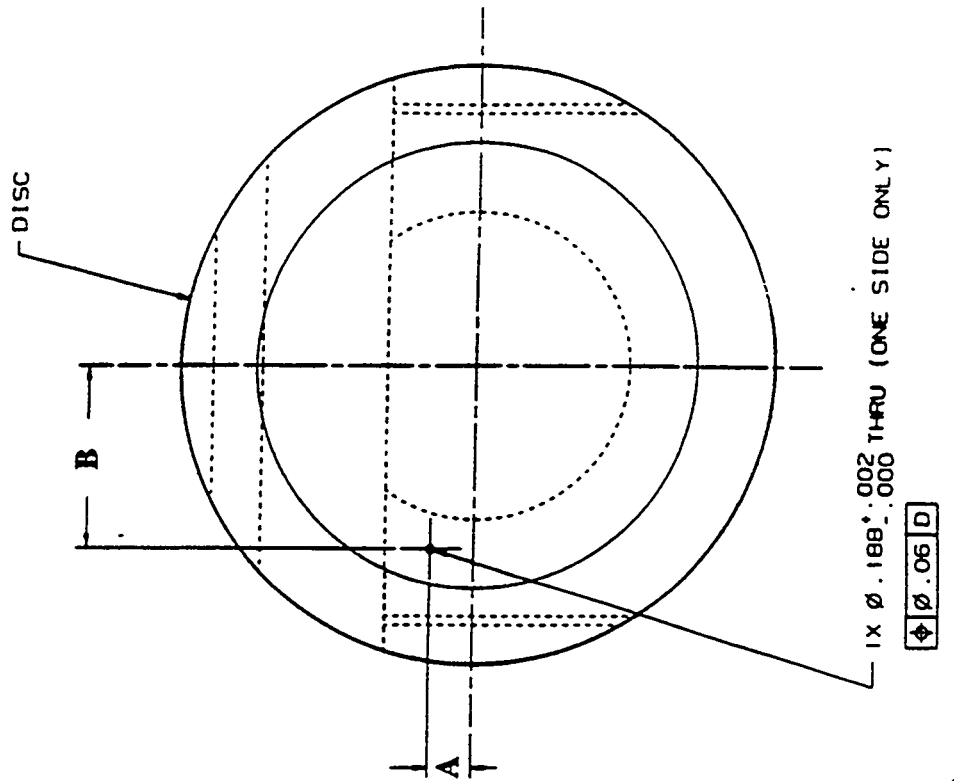
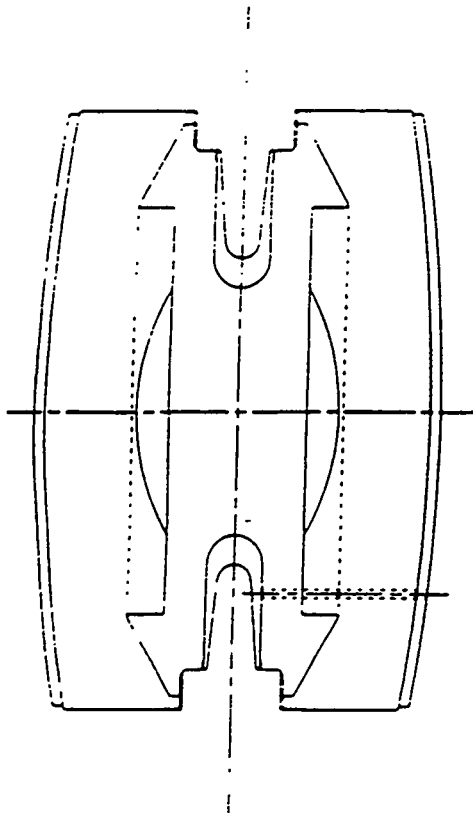
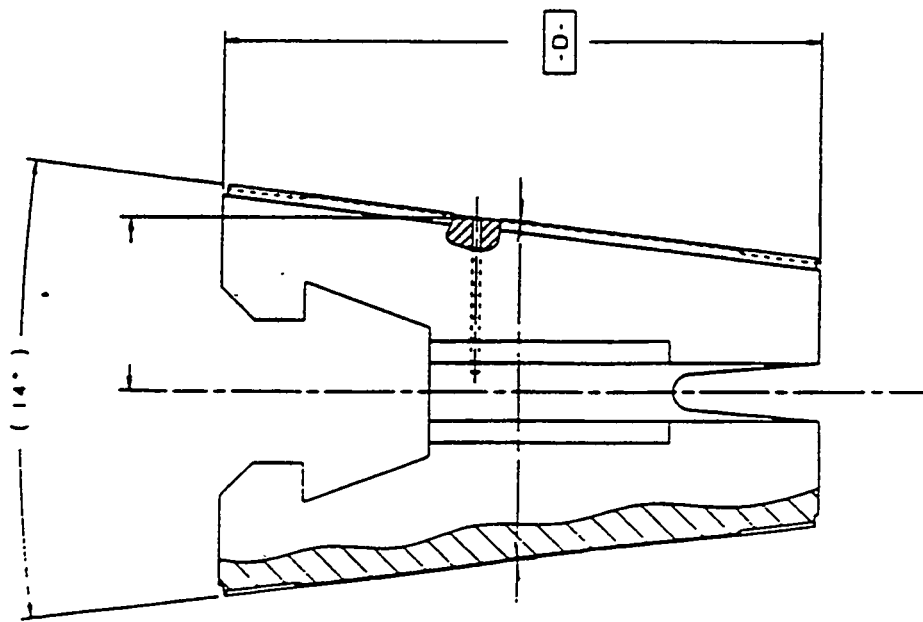

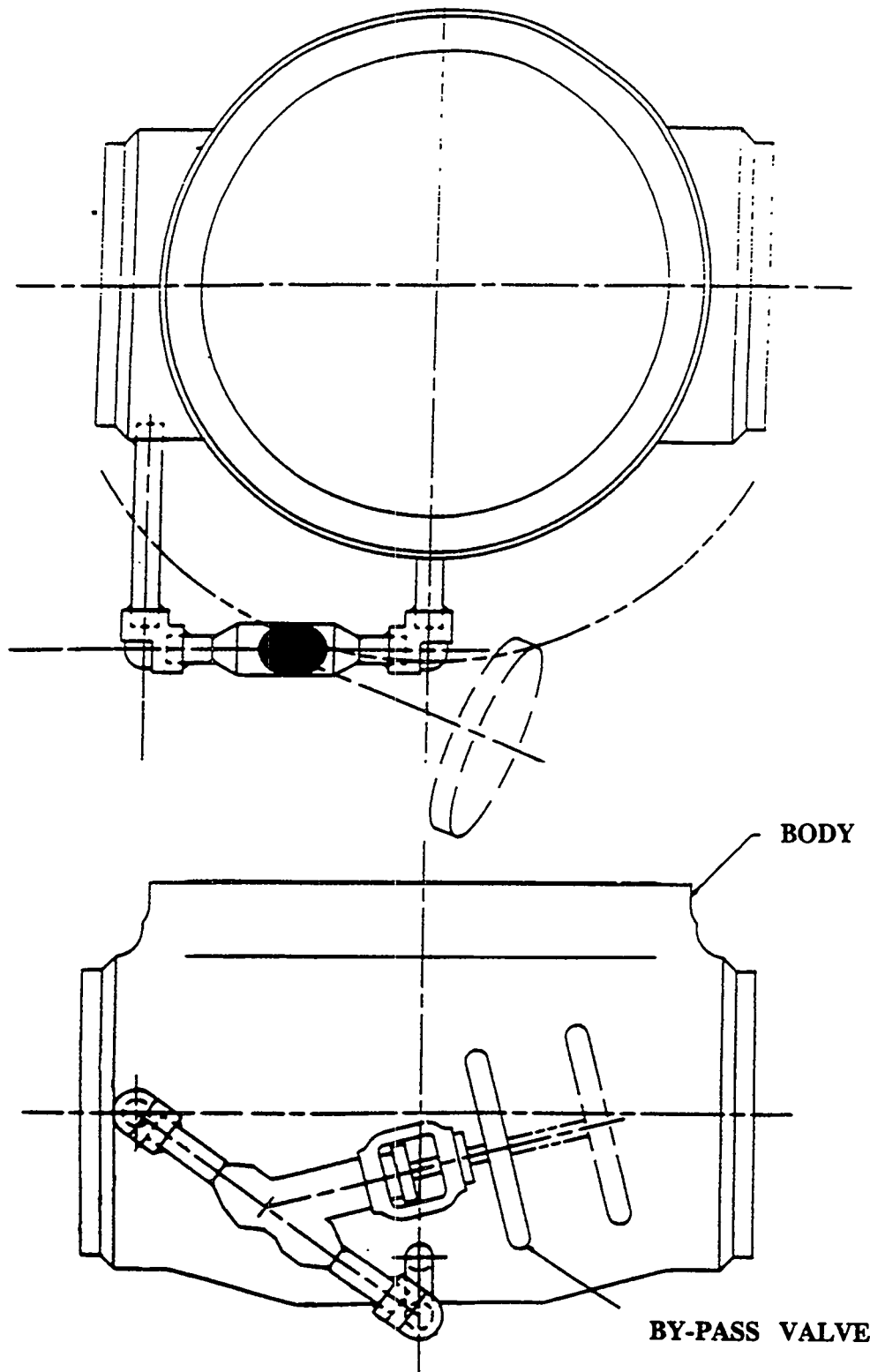

FIGURE SHOWING BONNET BY-PASS

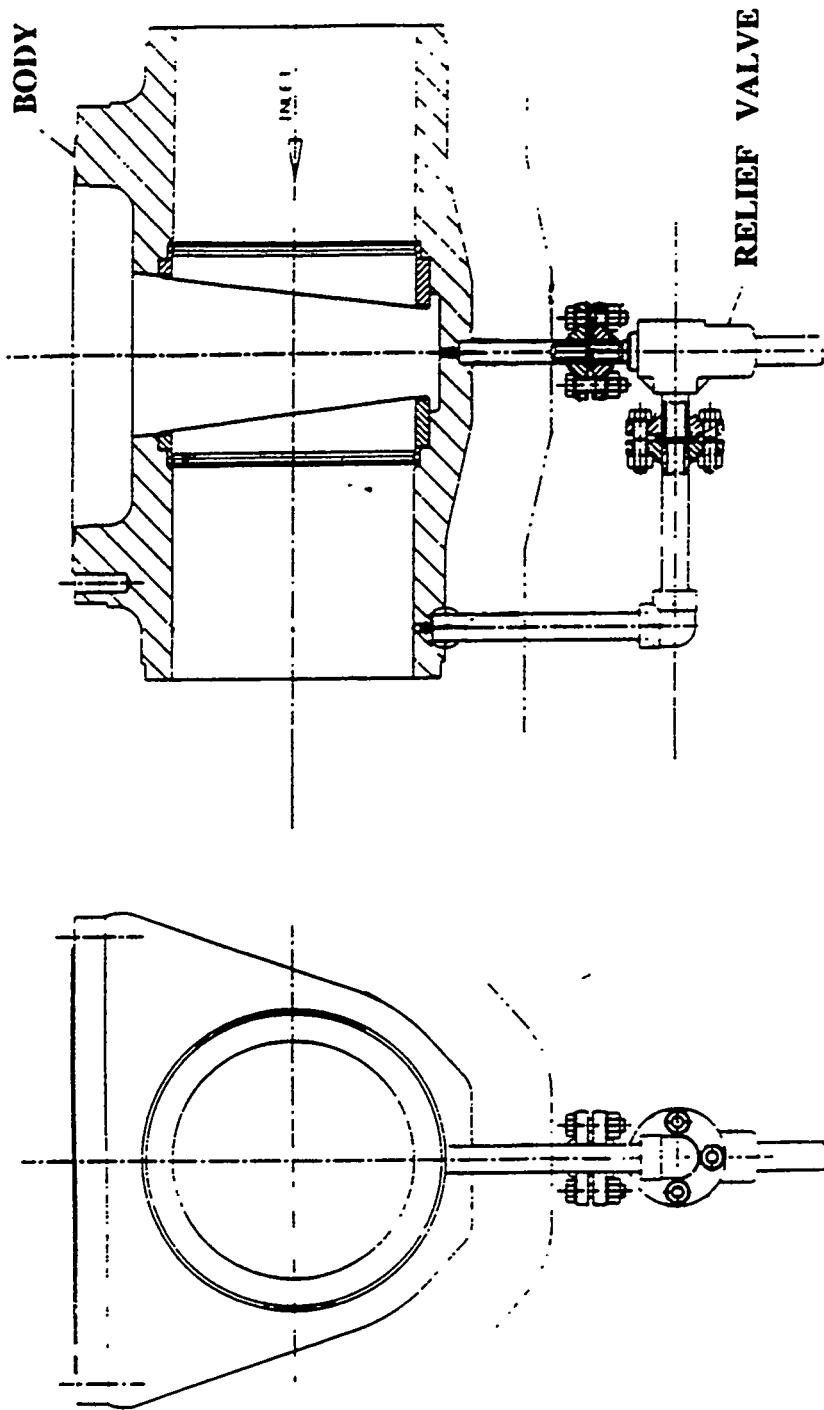

FIGURE SHOWING RELIEF VALVE INSTALLATION

W 17/23

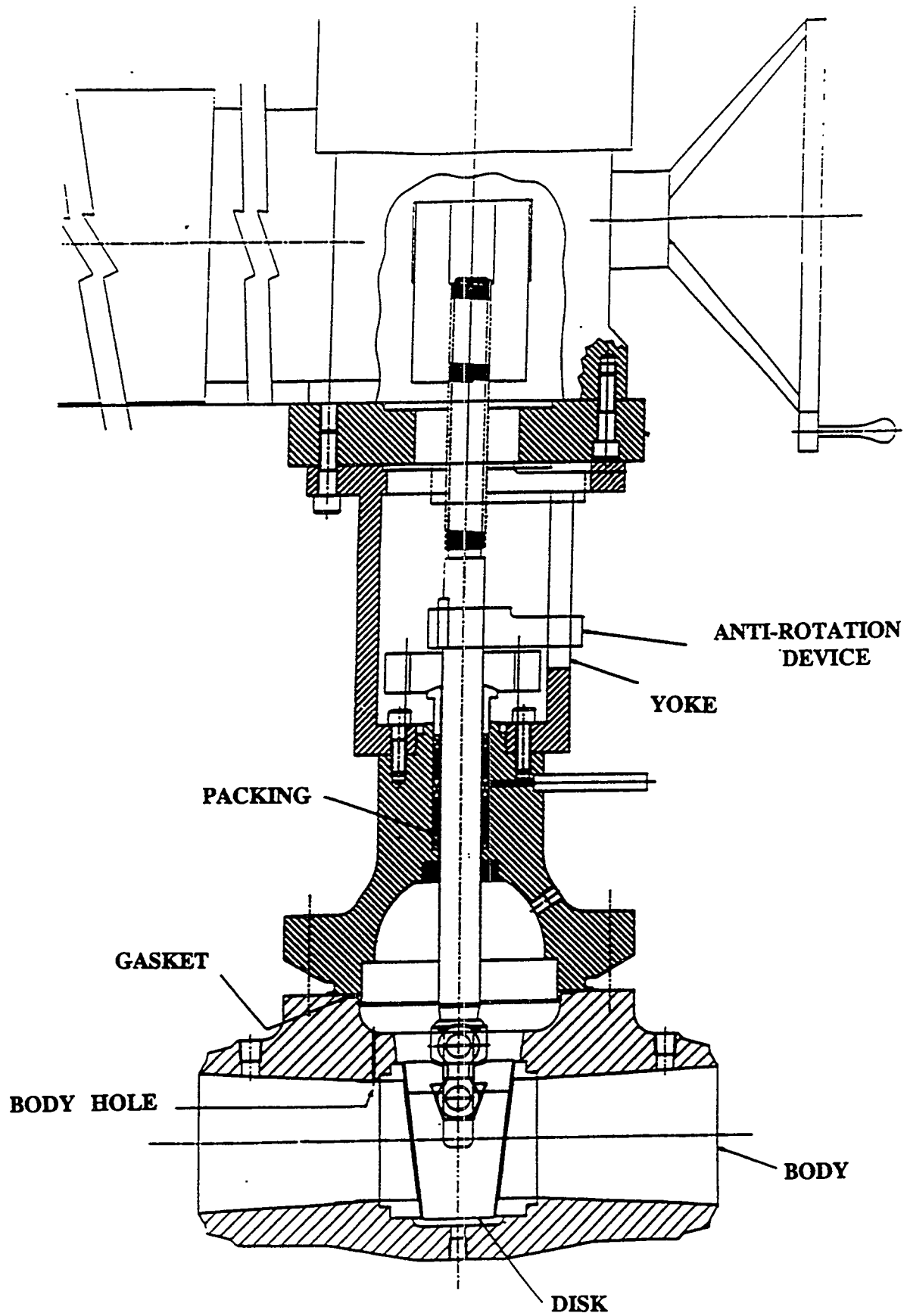

FIGURE SHOWING BODY DRILLING

**Table 2
Pressure Locking Hardware Mitigating Approaches**

Features	Advantages	Disadvantages
By-pass line	<ul style="list-style-type: none"> Provides unrestricted flow path between bonnet and upstream pipe Disc can be reversed 	<ul style="list-style-type: none"> o External piping subject to external damage o Reverse flow leakage o Potential to fatigue failure of piping o Piping analysis required o Difficult to convert to original configuration o More hardware to maintain
By-pass with shut-off valve	<ul style="list-style-type: none"> Same as above Can be isolated for hydro-test Disc can be reversed 	<ul style="list-style-type: none"> o External piping subject to external damage o Potential to fatigue failure of piping o Reverse flow leakage o Piping Analysis required

**Table 2
Pressure Locking Hardware Mitigating Approaches**

Features	Advantages	Disadvantages
Drilling a hole on a disc face	Can be performed in the field Very simple No seismic effects	<ul style="list-style-type: none"> o Reverse flow leakage o Hole can be reversed during installation o Replace disc to convert to original configuration
Drilling a hole on the body	Simple for maintenance No seismic effects	<ul style="list-style-type: none"> o Difficult to implement in field o Can be plugged depending on size and location
Relief Valve	Disc can be reversed Good leaktightness Disc can be reversed	<ul style="list-style-type: none"> o More hardware to maintain o Active element subject to regulatory attention o External piping subject to external damage o More complicated to size, design and implement o Potential to fatigue failure of piping o Piping analysis required

Table 3

Responsibilities and Action for Pressure Locking and Thermal Binding Mitigation

Organization	Issue	Actions
Valve Designer	Pressure Locking	<ul style="list-style-type: none"> Size actuator correctly Body Drilling (if requested) Disc Drilling (if requested) Install by-pass line (if requested) Install relief valve (if requested)
	Thermal Binding	<ul style="list-style-type: none"> Perform thermal testing Perform functional/operability tests Define valve nozzle load limits Specify appropriate seating loads
Plant Designer	Pressure Locking	<ul style="list-style-type: none"> Install valves away from temperature source Specify transients the valves are subjected to Define layout configuration Define valve requirements clearly to vendor
	Thermal Binding	<ul style="list-style-type: none"> Limit nozzle loads to vendor limits

**Table 3
Responsibilities and Action for Pressure Locking and Thermal Binding Mitigation**

Organization	Issue	Actions
Plant Operator	Pressure Locking	<p>Establish procedures to allow trapped high pressure fluid to relieve following mode changes</p> <p>Analyze as-built configuration for problem spots and modify to suit</p>
	Thermal Binding	<p>Minimize exposing the valve to unanalyzed transients (thermal shock)</p> <p>Establish procedures to allow temperature to stabilize before maneuvering valves</p> <p>Analyze as-built configuration for problem spots and modify to suit</p> <p>Cycle the valve during cooldown modes</p> <p>Avoid excessive closing loads</p> <p>Consult valve vendors in root cause evaluations and subsequent modifications</p>

INSIGHTS

- ☛ PRESSURE LOCKING/THERMAL BINDING REMAIN POTENTIAL PROBLEMS
- ☛ SOLUTIONS EXIST AND MUST BE COORDINATED BETWEEN SUPPLIERS AND USERS
- ☛ INVOLVE SUPPLIERS IN ROOT CAUSE EVALUATIONS AND REVIEWS

r:\mcs\hmv\0146\0146

Vendor Actions
Drew W. Wright, Anchor/Darling Valve Co.

Research Engineer
Anchor/Darling Valve Co.
Williamsport, PA

(Enclosure 11)

Pressure Locking and Thermal Binding In Gate Valves

NRC Workshop
February 4, 1994
New Orleans, LA

Drew W. Wright
Research Engineer
Anchor/Darling Valve Co.

I. Introduction:

A wide variety of gate valve designs are susceptible to pressure locking and/or thermal binding of the disc when a valve is in the closed position. The potential for such conditions is a function of both the valve design and system parameters. However, all gate valve designs are believed to be potentially susceptible to at least one of these phenomena, unless specific preventative features have been incorporated into the valve design.

II. Description of Phenomena:

a) Pressure Locking:

Pressure locking can occur as a result of two situations, or a combination thereof. Entrapping fluid in the bonnet cavity upon closure and subsequently heating the fluid can result in pressure locking. The increased pressure may cause valve damage, or render the valve inoperable. Pressure entrapment upon closure can also prevent the valve from being opened in the event of rapid de-pressurization in the adjacent upstream piping.

Pressure locking has been known to occur in both wedge-type and parallel seated gate valves.

Figures 1.0 and 2.0 depict a pressure locked condition for bolted bonnet and pressure seal designs, respectively.

In the worst cases, pressure locking (also known as bonnet over-pressurization), has resulted in catastrophic failure of the pressure boundary, and loss of life.

b) Thermal Binding:

Thermal binding occurs as a result of differential contraction between the valve body and the valve disc as the system cools. The differential contraction can cause the disc to become tightly pinched in the valve seats, rendering the valve inoperable. Thermal binding is a concern for wedge-type gate valves. However, in general, parallel seat designs are less susceptible this phenomenon.

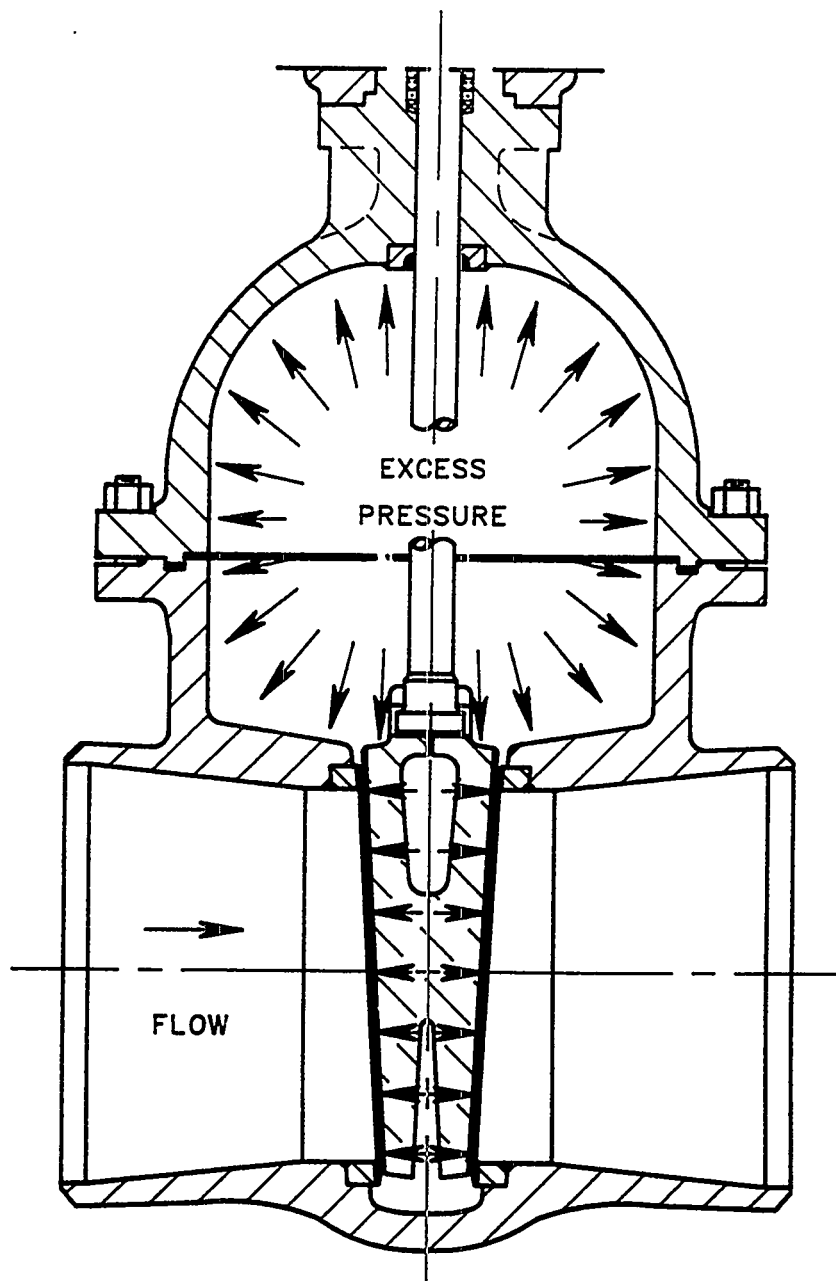

PRESSURE LOCKED CONDITION
BOLTED BONNET DESIGN

Figure 1-0

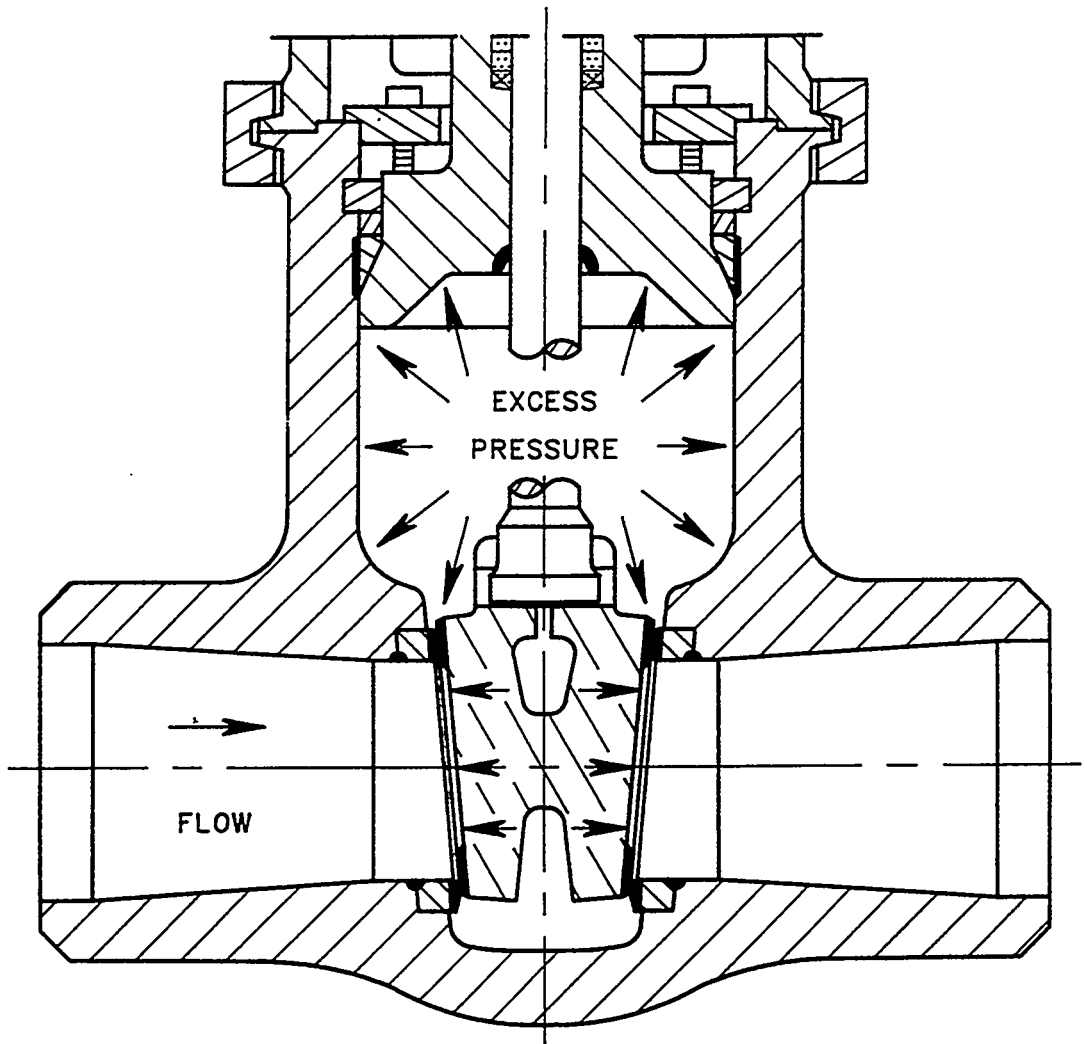

PRESSURE LOCKED CONDITION
PRESSURE SEAL DESIGN

Figure 2-0

III. Experiences:

- a) Pressure Locking: Typically encountered during start-up operations.
 - 1) 1970's, 18"-300#-DD (A/DV): PWR plant where dead-heading pump against valve caused fluid temperature to rise. Discs bowed outward and had to be cut out.
 - 2) 1980's, DD (A/DV): PWR plant experienced pressure locking on start-up.
 - 3) 18"-FW (non-A/DV): Flex wedge valve in feedwater pump discharge system. Seat rings collapsed from pressure locked condition.
 - 4) FW (non-A/DV): Discharge recirculation valve pressure locked during start-up.
 - 5) 10"-900#-DD (A/DV): Pressure locked during start-up. Valve installed in vertical leg of steam system.
- b) Thermal Binding: Typically encountered during shutdown operations.
 - 1) Experienced on valves from a variety of manufacturers. At least one case has resulted in the stem being pulled out of the T-head when attempting to open the valve.

IV. Suggestions For Identifying Problem Valves:

The identification of valves that may be subject to potential pressure locking and/or thermal binding requires a review of system conditions that are possessed by only the end user. Therefore, the end user is ultimately responsible for such evaluations. However, there are certain basic recommendations that A/DV can offer to assist in the process. This criteria is not intended to be comprehensive, as there is certain to be additional criteria that is applicable.

- a) Pressure Locking/Bonnet Over-pressurization:
 - 1) Identify normally-open gate valves that, once closed, are subject to temperature rise prior to reopening (i.e. primarily start-up operations).
 - 2) Identify normally-closed gate valves that are subject to substantial temperature transients.

- b) Thermal Binding:
 - 1) Identify normally-open wedge-type gate valves that are closed prior to system cooling (i.e. shut-down operations).
 - 2) Identify wedge-type gate valves having dissimilar body and disc base materials (i.e. CS vs SS).

V. Corrective Measures:

There are both design and operating measures that can be taken to preclude pressure locking, and minimize the potential for thermal binding. However, the available design measures are not employed as standard practice. Therefore, it is crucial that design specifications for new valves explicitly identify those valves that are subject to pressure locking or thermal binding conditions. Preventative measures that can be incorporated in the field, or during original design include the following:

- a) Pressure Locking:
 - 1) Drilling a hole in the upstream disc (see Figures 3.0 and 4.0).
 - 2) Connection of an external vent or relief valve (see Figure 5.0).
 - 3) Connection of an external bypass line with an isolation valve (see Figure 6.0).
 - 4) Drilling a hole through the body bridge behind the upstream seat (see Figure 6.0).
- a) Thermal Binding:
 - 1) Periodically opening and closing a suspect valve during system cool-down.
 - 2) Use of a spring compensating actuator to limit inertial closing forces.
 - 3) Avoid use of excess closing thrusts.

VI. Published A/DV Bulletins:

Anchor/Darling published an On-Line regarding bonnet over-pressurization in July of 1985.

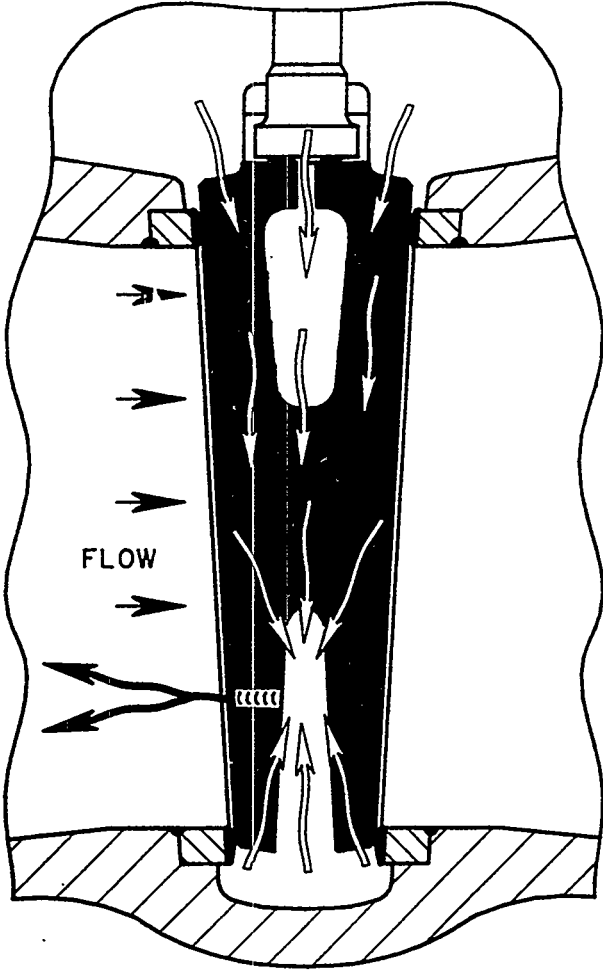

CORRECT DRILLING LOCATION

Figure 3-0

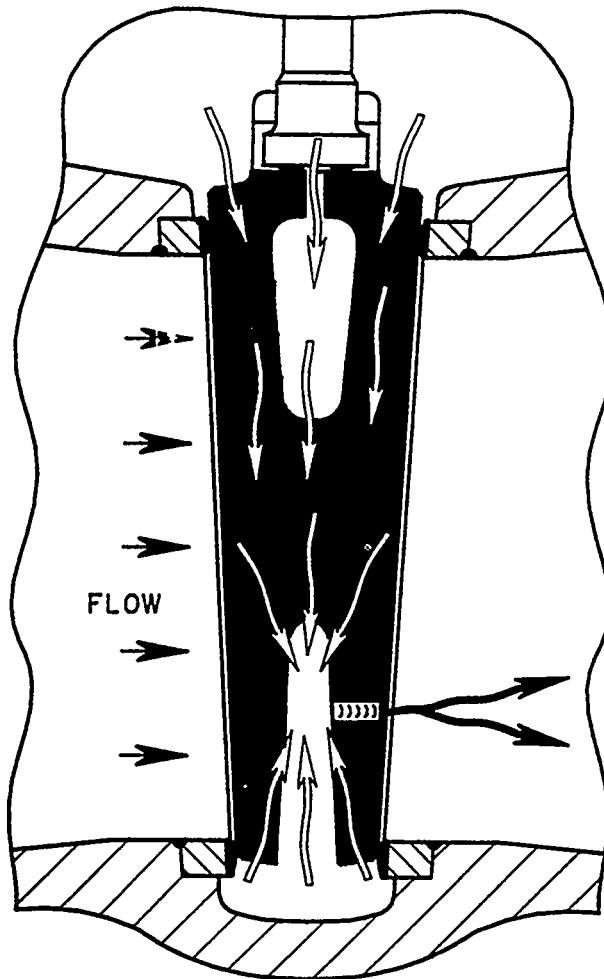

INCORRECT DRILLING LOCATION

Figure 4-0

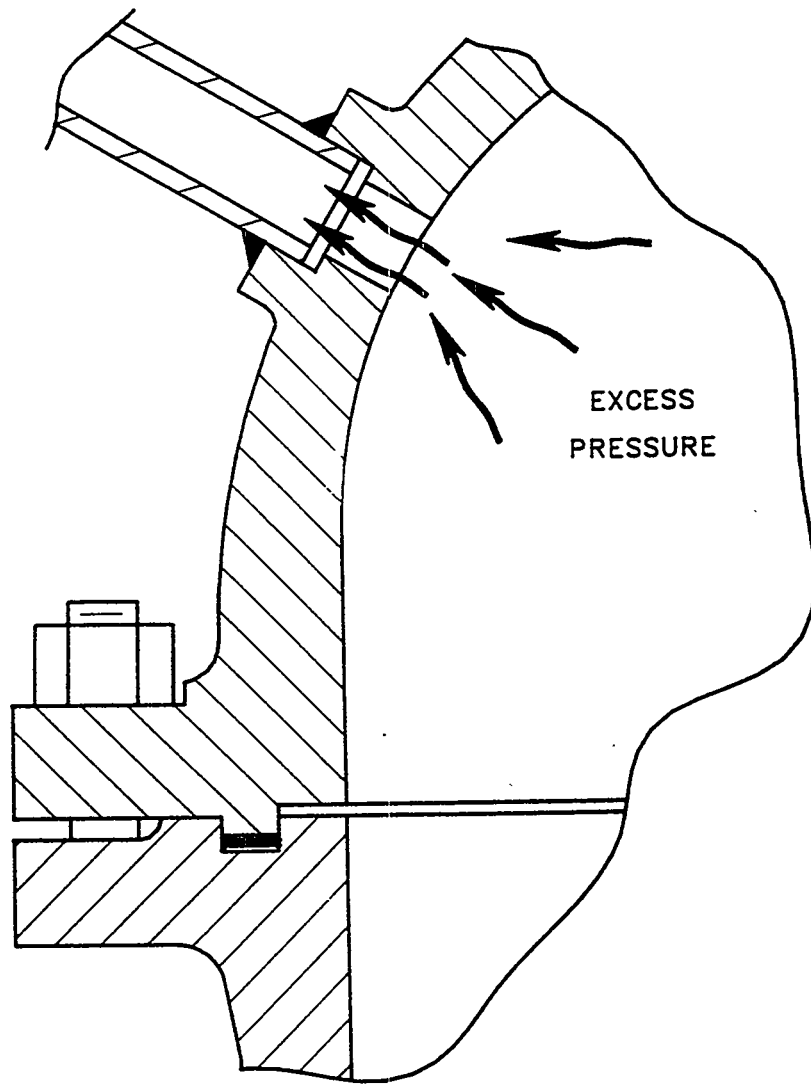

CONNECTION FOR
EXTERNAL RELIEF VALVE

Figure 5-0

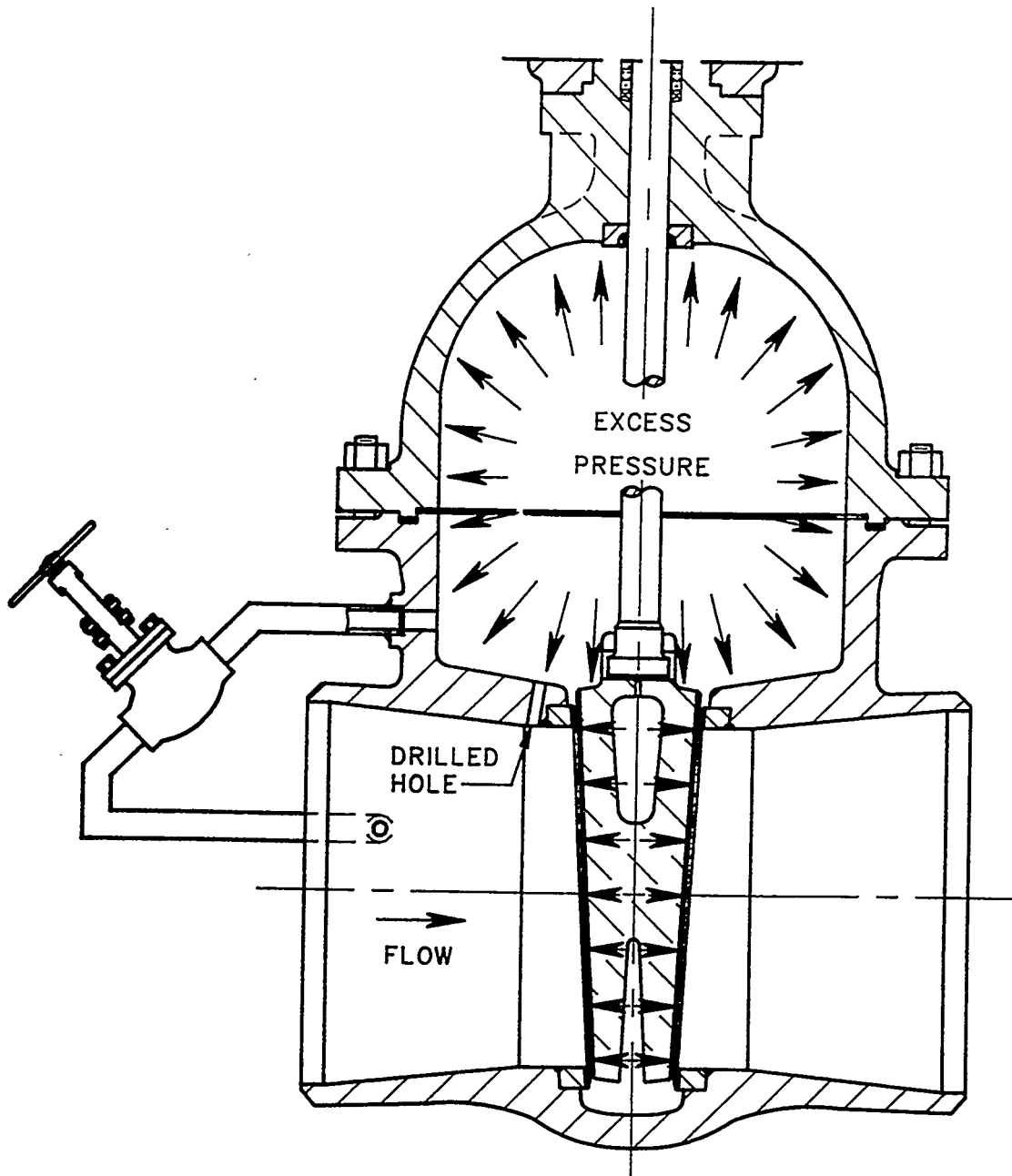

EXTERNAL BYPASS OR HOLE THRU BRIDGE

Figure 6-0

Vendor Actions
John M. Farrell, Velan Valve Corporation

Corporate Manager of Engineering
Velan Valve Corporation
Montreal, Quebec, Canada

(Enclosure 12)



THERMAL BINDING and PRESSURE LOCKING in GATE VALVES

VELAN EXPERIENCE

by

JOHN M. FARRELL

CORPORATE MANAGER of ENGINEERING

VELAN VALVE CORPORATION

Presentation Overview:

This presentation is a summary of the work performed by Velan Valve Corporation in efforts to understand and correct the problems associated with thermal binding and pressure locking in gate valves.

1) Thermal Binding

To resolve a problem, not on a nuclear valve but on a refinery valve operating at 1000 °F, a series of tests was performed on some 10", 16" and 20" 600 lb. forged gate valves. The problem was severe thermal binding of the wedge following closure at 970 °F and subsequent cooling to 300 °F. The test set-up is shown on pages 6 & 7. To determine the mechanism of binding various sequences of closure/cooling were followed, page 8 (Test Sequence).

The most significant finding was that it appeared that most, if not all, of the thermal binding took place due to expansion of the wedge, which was slightly cooler in the neck of the valve in the open position than were the main body of the valve and the seats. To determine if shrinkage of the body on the seat was significant, sequences (2) and (3) were performed. It appeared that as the valve cooled the binding actually reduced. The binding found after cool down was attributed to the residual effect of the binding caused in Sequence (1).

-Page 1-

This finding was valuable in that it meant analysing the wedge only and not having to worry too much about the body. The analysis method is shown in page 10 and test loads v's calculated loads are shown in page 11.

The overall solution to the problem was to minimise the amount of excess material in the wedge, giving increased flexibility without increasing the stresses beyond code allowables. The opening loads were reduced from greater than 100,000 lbs to less than 30,000 lbs in the case of the 20" valve.

2) **Pressure Locking:**

Test work was performed on gate valves of various pressure classes to determine the relative contribution of the differential area due to the seat angle (i.e. the projected area of the inclined seat) and the spreading effect of the wedge, similar to the disc loading of double disc valves. The figure on page 13 depicts this situation.

The tests consisted of comparing the opening to the closing thrusts with and without pressure in the valve. The load due to the differential area was considered to be fully defined by the equation for L_1 on page 15. The load due to the wedging action of closing ($T_1 - T_2$) was considered to be unchanged due to the pressure load; therefore the load due to double disc drag (L_2) could be calculated.

It appears that the double disc drag is a function of the flexibility of the wedge and possibly the body. Testing is continuing to determine the relationship between these flexibilities and the values of the pressure binding.

SUMMARY:

Thermal binding in wedge gate valves can be minimised by (a) closing the wall slightly less than 100% to allow the wedge to warm up before fully closing; (b) make wedge as flexible as possible.

Pressure locking can be overcome by drilling a hole in the wedge or seat, providing an intergate bypass or drain, or supplying a pressure relief valve.

Velan: Montreal 02/Mar/94



THERMAL BINDING
and
PRESSURE LOCKING
in Gate Valves

CAUSE - EFFECTS
and SOME SOLUTIONS

THERMAL BINDING

CAUSES

SHRINKAGE of BODY on WEDGE?

or

EXPANSION of WEDGE in BODY?

or

BOTH

TEST to FIND ANSWER

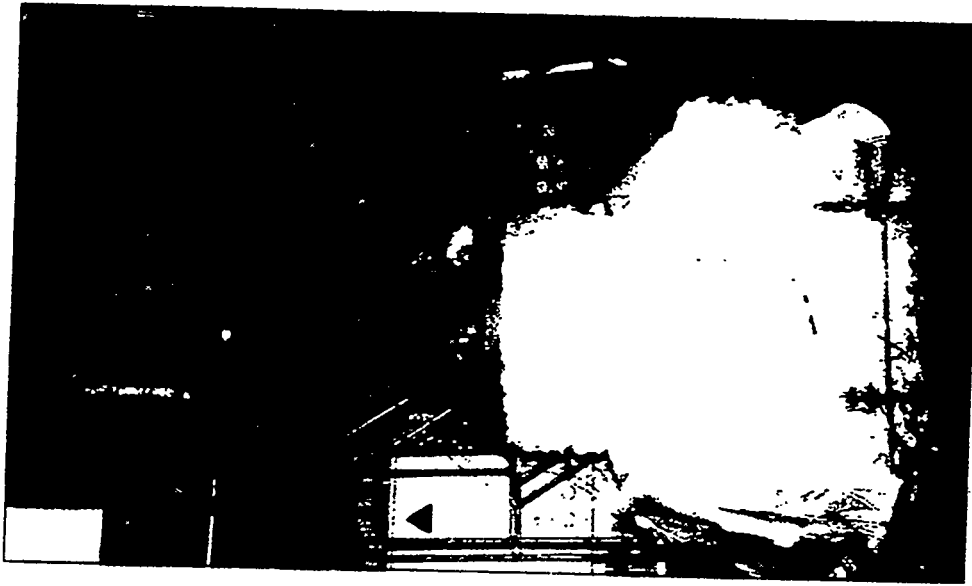

Setup for heat loss at 975 F

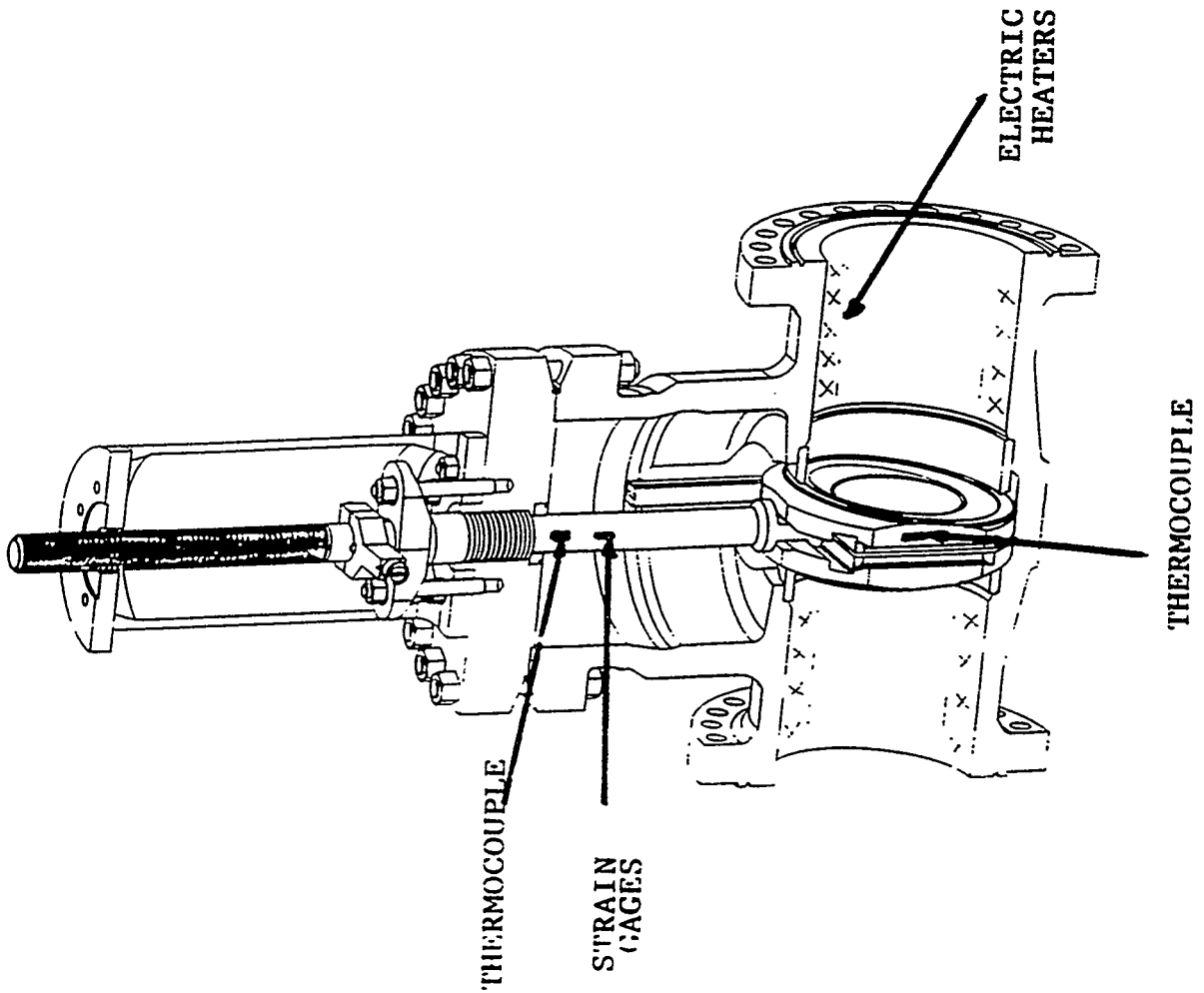

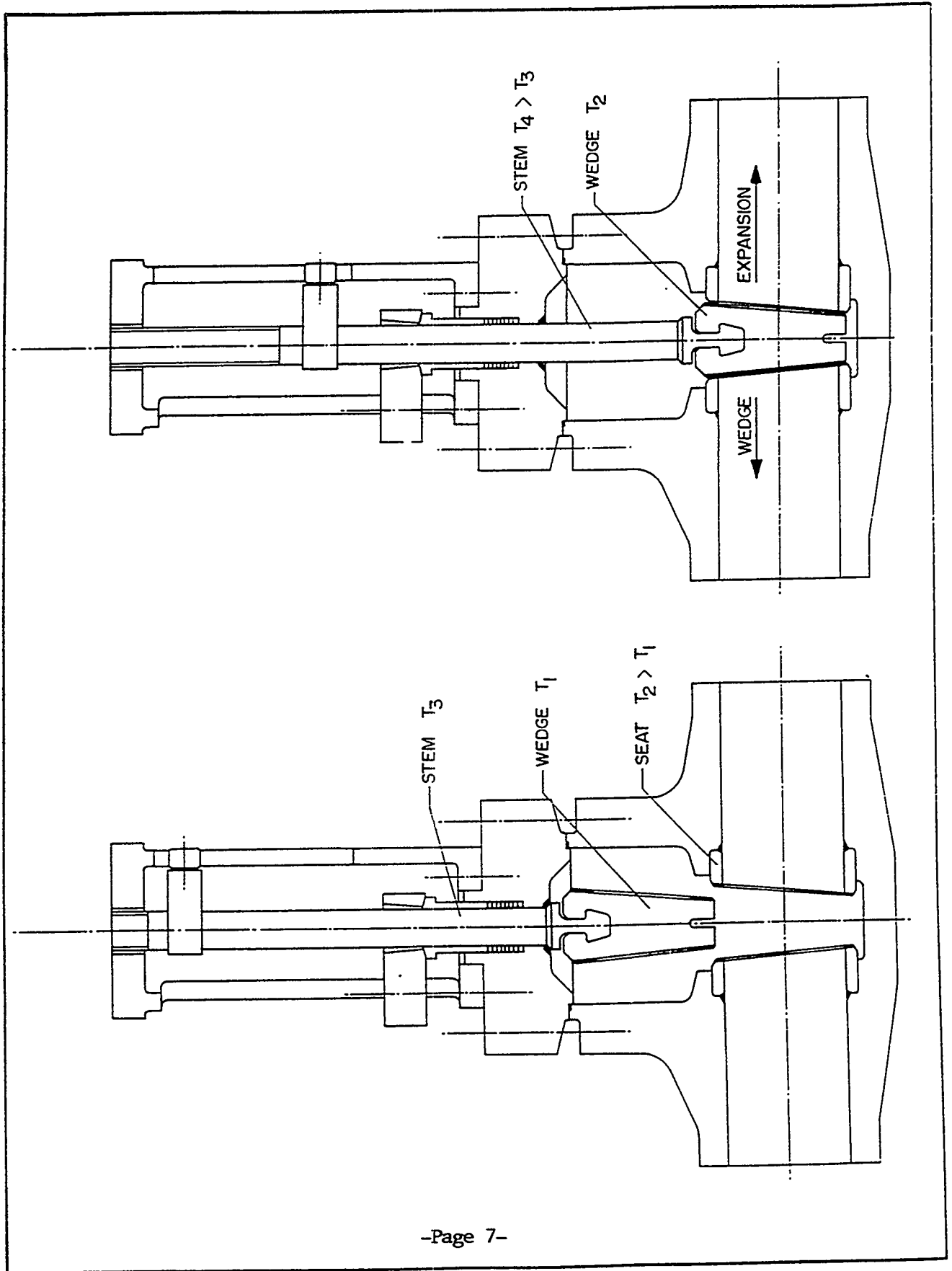

TEST SEQUENCE

OPEN VALVE HEATED to 975 °F.

STEM, BODY, WEDGE TEMPERATURE MEASURED

	(1)	(2)	(3)
(A)	<u>VALVE CLOSED</u> -Stem, wedge temp. -Stem thrust -Stem Expansion	<u>VALVE CLOSED</u> Same as (1)	<u>VALVE CLOSED 95%</u> When wedge temp. = Body temp. valve closed 100%
(B)	<u>VALVE OPEN</u> When wedge temp. = Body Temp.	<u>VALVE OPEN</u> When valve cooled to ambient	<u>VALVE OPEN</u> When valve cooled to ambient
Measure:	Stem Thrust	Stem Thrust	Stem thrust

RESULTS

High Thermal Binding	No Thermal Binding
Low Thermal Binding	No Thermal Binding

CONCLUSION

**MAJORITY OF THERMAL BINDING DUE TO WEDGE
EXPANSION AFTER CLOSURE**

SOLUTION

**DEVELOP ANALYTICAL METHOD TO ESTIMATE
BINDING LOAD.**

REDESIGN WEDGES WHERE NECESSARY

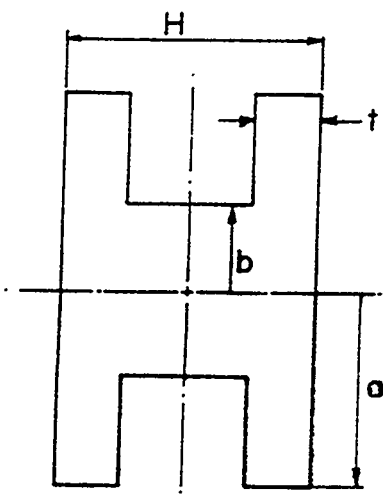

a

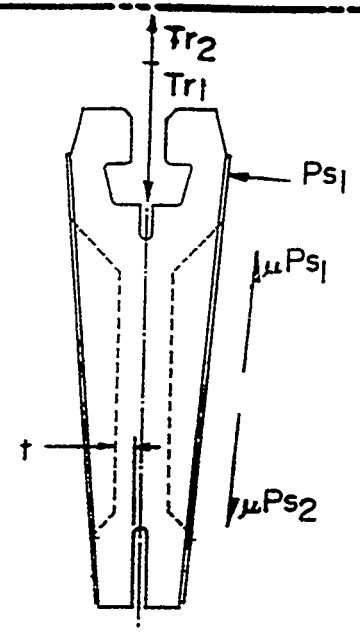

b

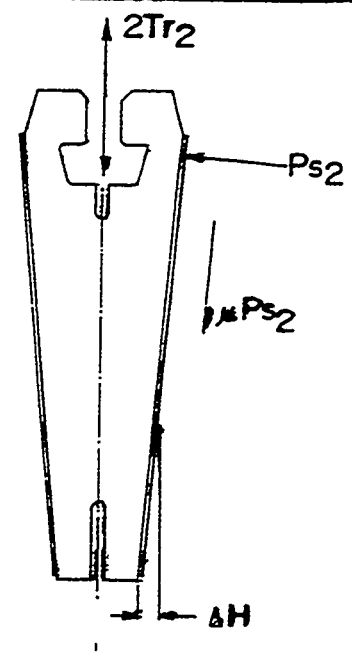

c

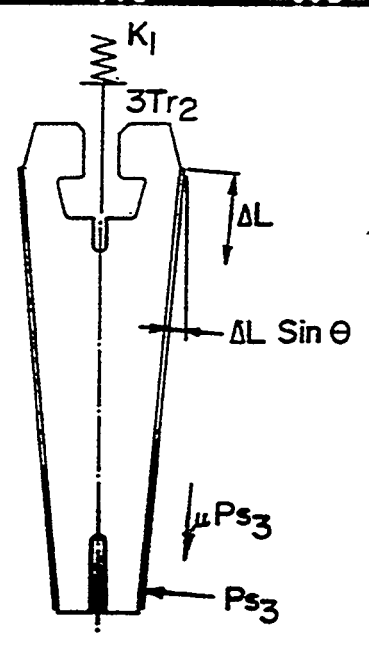

d

$$Tr_2 = 2(\mu \cos \theta - \sin \theta) \left[\frac{Tr_1}{2(\sin \theta + \mu \cos \theta)} + \frac{HTw \sigma Et^3}{2 \alpha a^2} + \frac{K_1 L \Delta t \sigma \sin \theta}{2 \sin \theta (\sin \theta + \mu \cos \theta) + \frac{K_1 \alpha t^2}{Et^3}} \right]$$

FIGURE --

WEDGE PULL FORCE

TESTED / CALCULATED

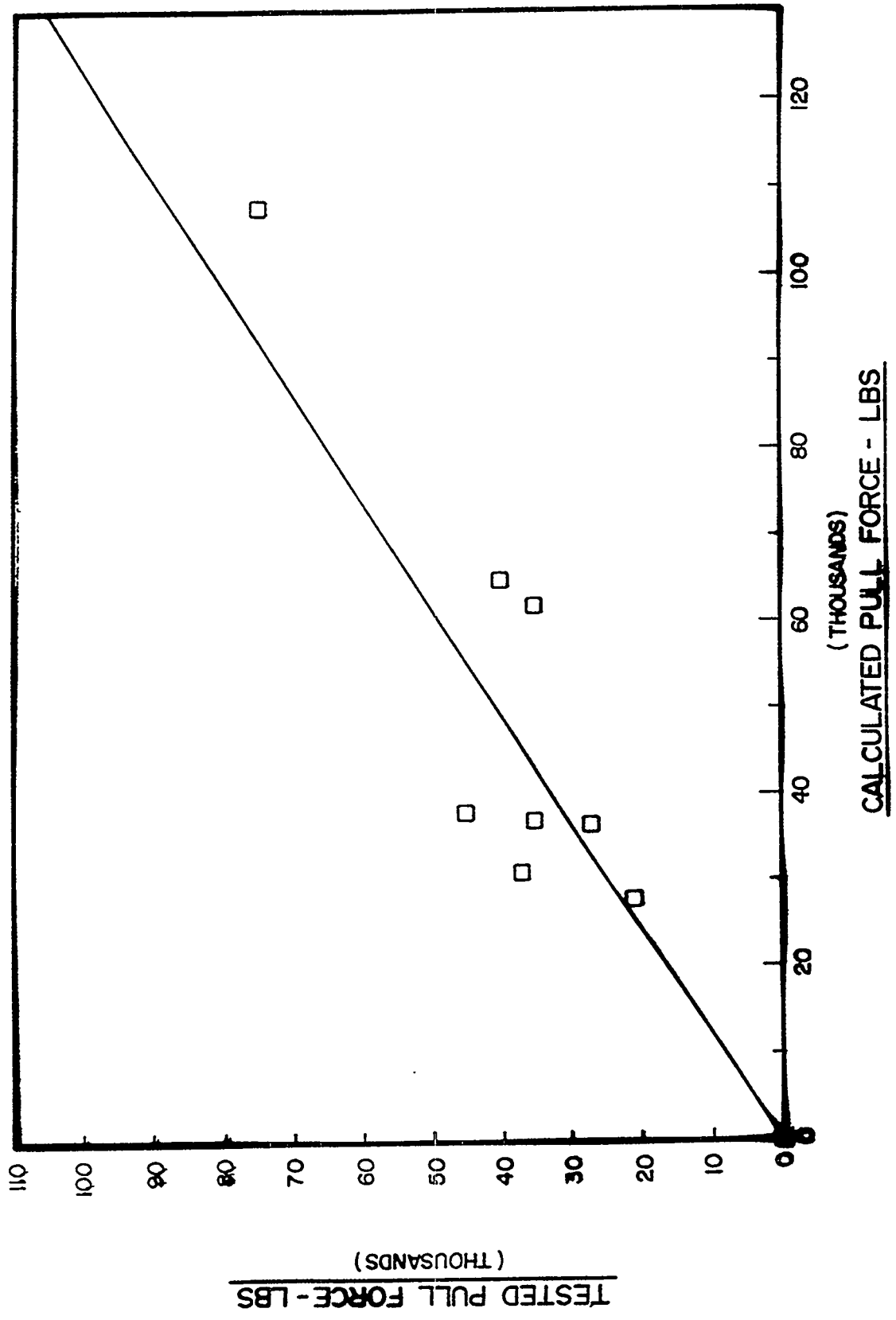

PRESSURE LOCKING

CAUSES:

1. ***TRAPPED PRESSURE IN CAVITY / LINES DEPRESSURISED.***
2. ***TRAPPED LIQUID IN CAVITY SUBSEQUENTLY HEATED.***
3. ***DIFFERENTIAL AREA OF ONE-PIECE WEDGE.***
4. ***DOUBLE DISC DRAG OF SPLIT TYPE DISCS.***

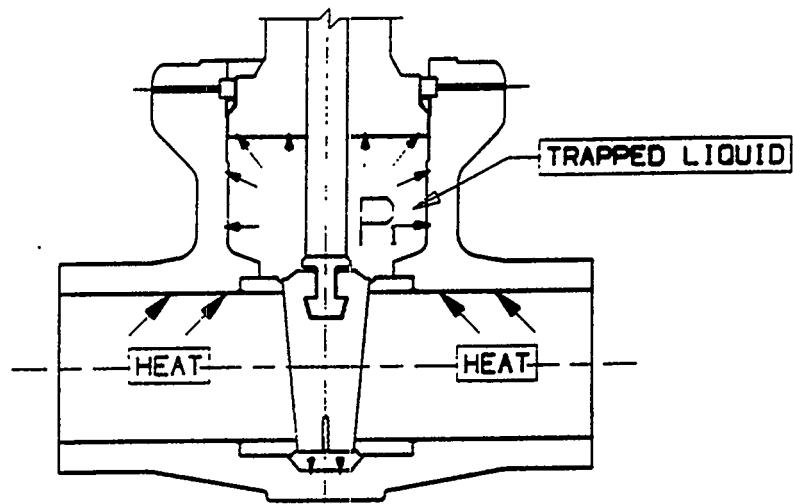

FIGURE 1

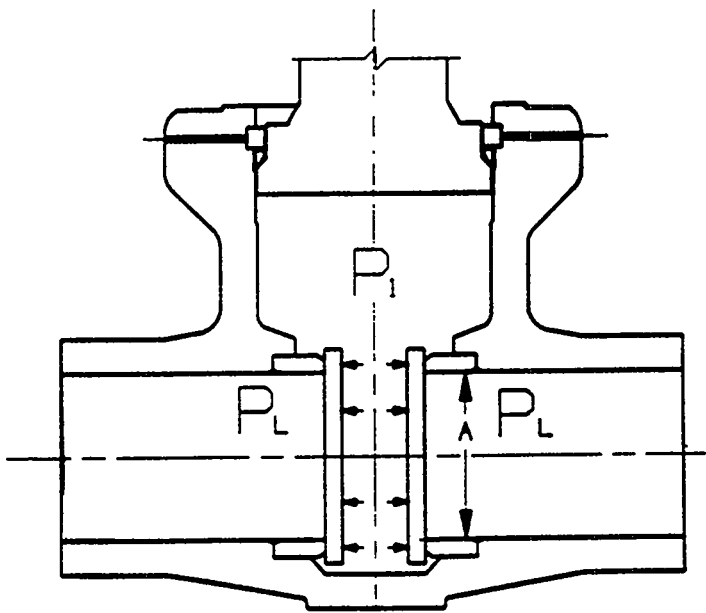

FIGURE 2

DOUBLE DISC TYPE

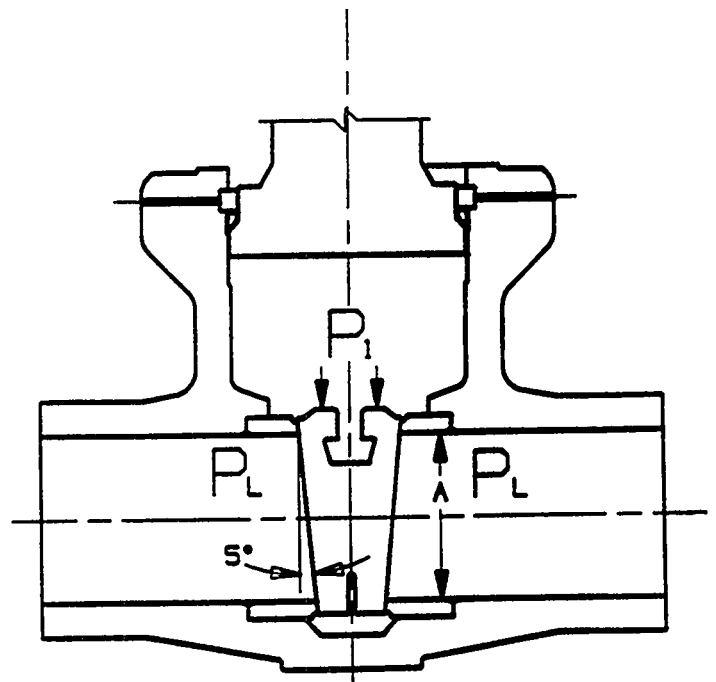

FIGURE 3

FLEXIBLE (ONE PIECE) WEDGE

TESTING:

**OBJECT: DETERMINE SEPARATE EFFECTS
OF DIFFERENTIAL AREA AND
DOUBLE DISC DRAG.**

PROCEDURE:

- 1. CLOSE VALVE WITH THRUST T_1 .**
OPEN VALVE THRUST T_2 .
- 2. CLOSE VALVE WITH T_1 .**
PRESSURISE CAVITY WITH P_1 .
OPEN VALVE THRUST T_3 .

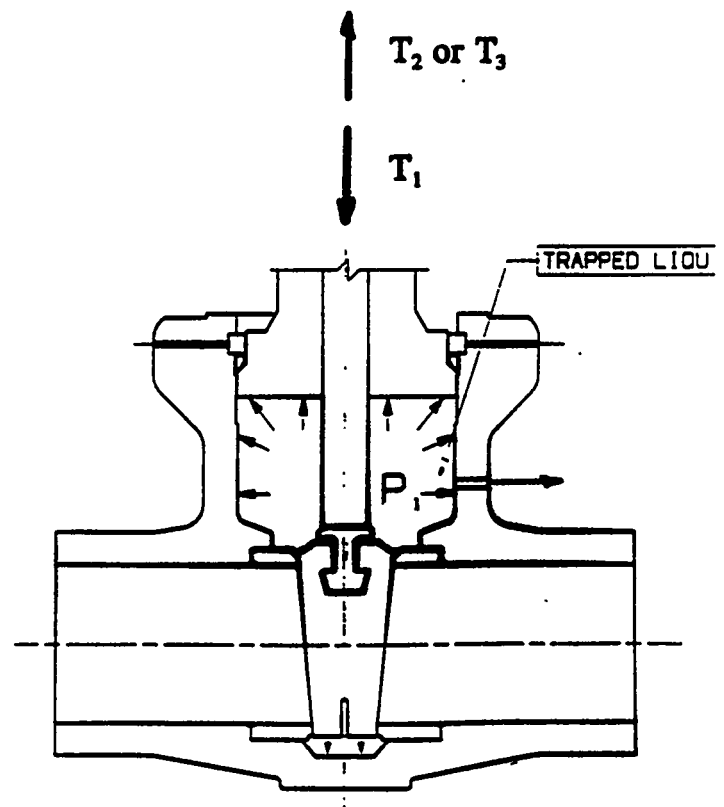

FIGURE 1

CALCULATION

LOAD DUE TO DIFFERENTIAL AREA

$$L_1 = 2 \times A \times \tan 5 \times P_1$$

LOAD DUE TO DOUBLE DISC DRAG

$$L_2 = T_3 - T_2 - L_1$$

TYPICAL RESULTS

<u>Valve:</u>	NO PRESSURE		<u>Press.:</u>	WITH PRESSURE		
	<u>Closing Load:</u>	<u>Open Load</u>		<u>OPEN LOADS</u>	<u>Diff. Area:</u>	<u>DD Drag:</u>
10" 900	30,000	18000	2000	35000	17000	0
10" 300	14,000	8000	500	21000	7000	6000

SOLUTIONS

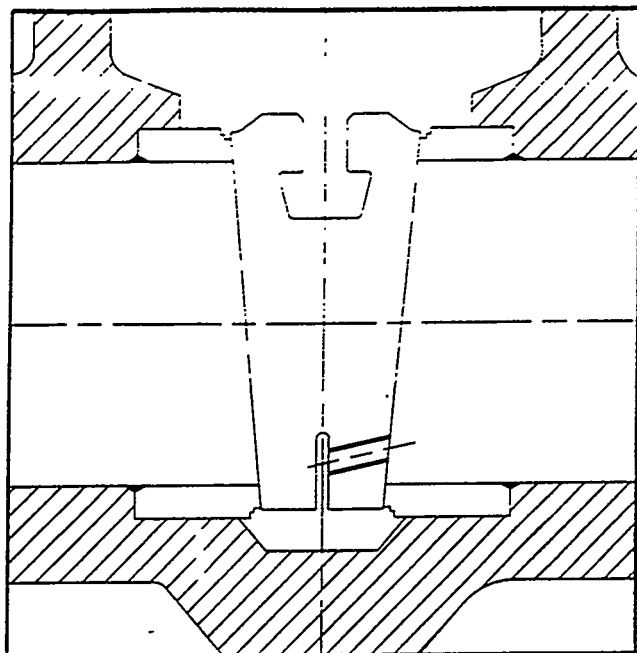

FIGURE 2
INTERNAL HOLE

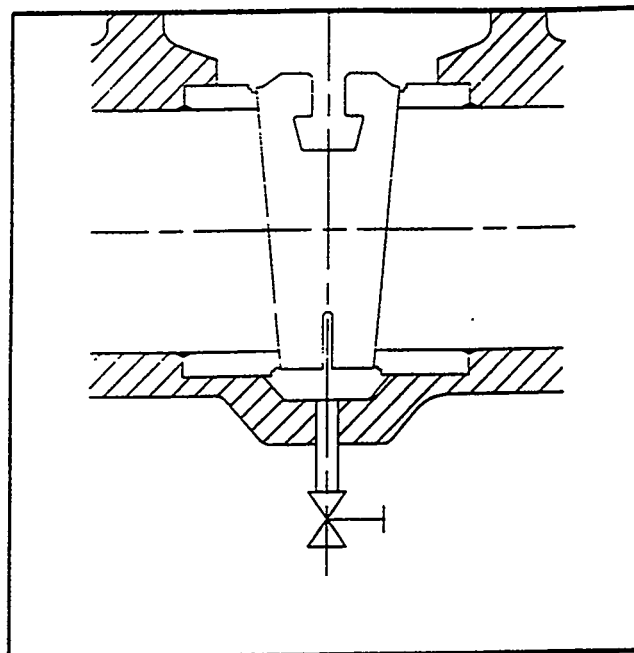

FIGURE 3
DRAIN/BYPASS

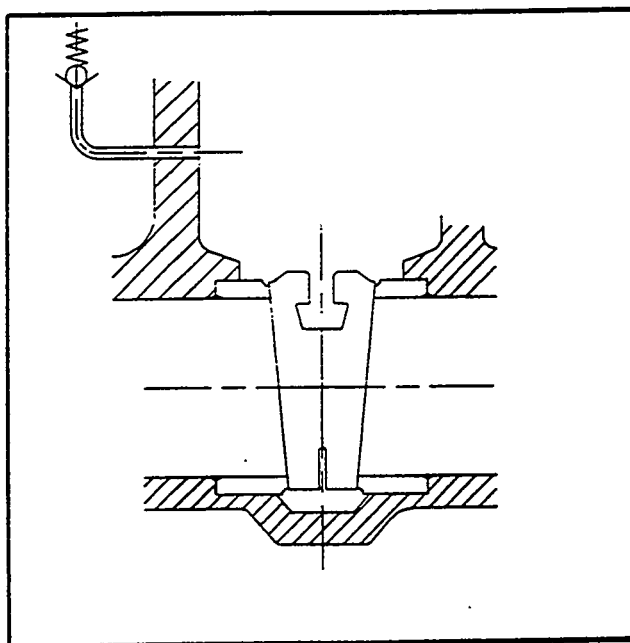

FIGURE 4
RELIEF VALVE

**Draft Generic Communication – U.S. Nuclear Regulatory Commission
Thomas G. Scarbrough**

**Mechanical Engineering Branch
Division of Nuclear Reactor Regulation
U.S. Nuclear Regulatory Commission**

(Enclosure 13)

**NRC STAFF ACTIVITIES
ON PRESSURE LOCKING AND THERMAL BINDING
OF GATE VALVES**

THOMAS G. SCARBROUGH

**MECHANICAL ENGINEERING BRANCH
DIVISION OF ENGINEERING
OFFICE OF NUCLEAR REACTOR REGULATION
U.S. NUCLEAR REGULATORY COMMISSION**

FEBRUARY 4, 1994

IN DECEMBER 1992, NRC OFFICE FOR ANALYSIS AND EVALUATION OF OPERATIONAL DATA COMPLETED SPECIAL STUDY S92-07, "PRESSURE LOCKING AND THERMAL BINDING OF GATE VALVES," WHICH WAS ISSUED AS VOLUME 9 OF NUREG 1275.

AT A PUBLIC WORKSHOP IN FEBRUARY 1993, NRC STAFF DISCUSSED THE SAFETY SIGNIFICANCE OF PRESSURE LOCKING AND THERMAL BINDING OF GATE VALVES.

NRC STAFF PREPARED GENERAL GUIDANCE FOR USE BY NRC INSPECTORS IN EVALUATING LICENSEE ACTION ON PRESSURE LOCKING AND THERMAL BINDING IN REVISION 1 TO TEMPORARY INSTRUCTION 2515/109 (JUNE 14, 1993) AND A MEMORANDUM (APRIL 30, 1993) TO THE REGION OFFICES. INSPECTORS REVIEWING LICENSEE ACTION ON THIS ISSUE ARE FINDING LITTLE PROGRESS IN THIS AREA.

ON FEBRUARY 8, 1993, NRC STAFF REQUESTED NUMARC TO PROVIDE SPECIFIC GUIDANCE ON ACCEPTABLE APPROACHES TO ANALYZE AND REMEDY PRESSURE LOCKING AND THERMAL BINDING OF GATE VALVES. AT A PUBLIC MEETING ON OCTOBER 4, 1993, NUMARC STATED THAT, BASED ON A SURVEY, IT HAD NOT FOUND PRESSURE LOCKING EVENTS BEYOND THOSE IDENTIFIED BY AEOD AND DID NOT PLAN TO TAKE ANY ACTION TO ADDRESS THIS ISSUE.

NRC STAFF PREPARING PROPOSED GENERIC LETTER TO REQUEST THAT LICENSEES ADDRESS PRESSURE LOCKING AND THERMAL BINDING OF GATE VALVES.

STAFF VIEWS OF PRESSURE LOCKING AND THERMAL BINDING:

- 1. PRESSURE LOCKING AND THERMAL BINDING MIGHT NOT OCCUR UNTIL PLANT CONDITIONS EXIST THAT REQUIRE OPERATION OF THE VALVE. THEREFORE, ABSENCE OF PREVIOUS EVENT NOT SUFFICIENT.**
- 2. EXAMPLES OF METHODS TO PREVENT PRESSURE LOCKING AND THERMAL BINDING DISCUSSED IN NUREG-1275, VOLUME 9.**
- 3. THRUST REQUIRED TO OVERCOME PRESSURE LOCKING OR THERMAL BINDING IS DIFFICULT TO PREDICT. IF POWER-OPERATED VALVE IS CONSIDERED CAPABLE OF OVERCOMING THRUST REQUIREMENT, METHODOLOGY USED TO PREDICT THE THRUST REQUIREMENT NEEDS TO BE BASED ON TESTING.**
- 4. IF POWER-OPERATED VALVE IS SUSCEPTIBLE TO PRESSURE LOCKING OR THERMAL BINDING, AND POWER OPERATOR CANNOT OVERCOME THRUST REQUIREMENT, THE VALVE MAY BE IN A DEGRADED OR NONCONFORMING CONDITION.**
- 5. GENERIC LETTER 91-18 PROVIDES GUIDANCE TO LICENSEES ON THE DISPOSITION OF POTENTIALLY DEGRADED OR NONCONFORMING CONDITIONS.**

6. IN THE EVENT A VALVE IS DETERMINED TO BE INCAPABLE OF PERFORMING ITS SAFETY FUNCTION, PERMISSION FOR CONTINUED PLANT OPERATION MAY BE REQUESTED WHILE CORRECTIVE ACTION TAKEN. EXAMPLES OF INFORMATION TO SUPPORT A JUSTIFICATION FOR CONTINUED OPERATION INCLUDE

- A. SYSTEM ARGUMENTS (USING REASONABLE VS. DESIGN-BASIS ASSUMPTIONS) TO SUPPORT LOW LIKELIHOOD OF PRESSURE LOCKING AND THERMAL BINDING PROBLEMS, AND**
- B. THRUST CAPABILITY UNDER NORMAL VOLTAGE CONDITIONS COMPARED TO ESTIMATED THRUST REQUIREMENT.**

NRC STAFF CONSIDERING THE NEED FOR LICENSEES TO

- 1. EVALUATE THE OPERATIONAL CONFIGURATION FOR EACH SAFETY-RELATED POWER-OPERATED GATE VALVE AND DOCUMENT THE BASES FOR THE DETERMINATION OF ITS SUSCEPTIBILITY TO PRESSURE LOCKING AND THERMAL BINDING, AND**
- 2. DETERMINE APPROPRIATE CORRECTIVE ACTION FOR SAFETY-RELATED POWER-OPERATED GATE VALVES IDENTIFIED AS SUSCEPTIBLE TO PRESSURE LOCKING AND THERMAL BINDING.**

NRC STAFF IS DETERMINING AN APPROPRIATE TIME NECESSARY TO COMPLETE ACTIONS TO ADDRESS PRESSURE LOCKING AND THERMAL BINDING.

TIME SCHEDULE:

- 1. WOULD NOT SUPERSEDE NRC REGULATIONS AND TECHNICAL SPECIFICATION REQUIREMENTS IF A POWER-OPERATED VALVE IS FOUND SUSCEPTIBLE TO PRESSURE LOCKING OR THERMAL BINDING AND IS INCAPABLE OF OVERCOMING THRUST REQUIREMENT, AND**
- 2. MIGHT BE INDEPENDENT OF SCHEDULE FOR GENERIC LETTER 89-10.**

BIBLIOGRAPHIC DATA SHEET

(See instructions on the reverse)

1. REPORT NUMBER
*(Assigned by NRC. Add Vol., Supp., Rev.,
and Addendum Numbers, if any.)*

NUREG/CP-0146

2. TITLE AND SUBTITLE

Proceedings of the Workshop on Gate Valve Pressure Locking
and Thermal Binding

3. DATE REPORT PUBLISHED

MONTH | YEAR

July | 1995

4. FIN OR GRANT NUMBER

5. AUTHOR(S)

Earl J. Brown

6. TYPE OF REPORT

Conference
Proceeding

7. PERIOD COVERED *(Inclusive Dates)*

February 4, 1994

8. PERFORMING ORGANIZATION - NAME AND ADDRESS *(If NRC, provide Division, Office or Region, U.S. Nuclear Regulatory Commission, and mailing address; if contractor, provide name and mailing address.)*

Safety Programs Division
Office for Analysis and Evaluation of Operational Data
U.S. Nuclear Regulatory Commission
Washington, D. C. 20555-0001

9. SPONSORING ORGANIZATION - NAME AND ADDRESS *(If NRC, type "Same as above"; if contractor, provide NRC Division, Office or Region, U.S. Nuclear Regulatory Commission, and mailing address.)*

Same as above.

10. SUPPLEMENTARY NOTES

11. ABSTRACT *(200 words or less)*

The purpose of the Workshop on Gate Valve Pressure Locking and Thermal Binding was to discuss pressure locking and thermal binding issues that could lead to inoperable gate valves in both boiling water and pressurized water reactors. The goal was to foster exchange of information to develop the technical bases to understand the phenomena, identify the components that are susceptible, discuss actual events, discuss the safety significance, and illustrate known corrective actions that can prevent or limit the occurrence of pressure locking or thermal binding. The presentations were structured to cover U.S. Nuclear Regulatory Commission staff evaluation of operating experience and planned regulatory activity; industry discussions of specific events, including foreign experience, and efforts to determine causes and alleviate the affects; and valve vendor experience and recommended corrective action. The discussions indicated that identifying valves susceptible to pressure locking and thermal binding was a complex process involving knowledge of components, systems, and plant operations. The corrective action options are varied and straightforward.

12. KEY WORDS/DESCRIPTORS *(List words or phrases that will assist researchers in locating the report.)*

pressure locking
thermal binding
MOV
gate valve
valve binding
flexible wedge
double disc

13. AVAILABILITY STATEMENT

Unlimited

14. SECURITY CLASSIFICATION

(This Page)

Unclassified

(This Report)

Unclassified

15. NUMBER OF PAGES

16. PRICE