

CONF-950787--12

SAND95-1471C

Modular Integrated Monitoring System (MIMS) Field Test Installations

Robert L. Martinez, David R. Waymire
Sandia National Laboratories
Albuquerque, New Mexico USA

REC'D
JUL 18 1995
OSTI

David A. Fuess, David W. Myers, Christopher I. Frerking
Lawrence Livermore National Laboratory
Livermore, California USA

Evan E. Filby
Idaho National Engineering Laboratory
Idaho Falls, Idaho USA

Abstract

The MIMS program is funded by the Department of Energy under the Office of Nonproliferation and National Security. The program objective is to develop cost effective, modular, multi-sensor monitoring systems. Both in-plant and ground based sensors are envisioned. It is also desirable to develop sensors/systems that can be fielded/deployed in a rapid fashion. A MIMS architecture was selected to allow modular integration of sensors and systems and is based on LonWorks technology, commercially developed by Echelon Corporation.

The first MIMS fieldable hardware was demonstrated at Lawrence Livermore National Laboratory. The field test, known within the DOE as the Item Tracking and Transparency (IT&T) demonstration, involved the collaboration and cooperation of five DOE laboratories (Sandia (SNL), Lawrence Livermore (LLNL), Pacific Northwest (PNL), Los Alamos (LANL), and Oak Ridge (ORNL)). The IT&T demonstration involved the monitoring of special nuclear material as it was transported around the facility utilizing sensors from the participating labs. The scenario was programmed to ignore normal activity in the facility until entry into the room where the material was stored.

A second demonstration, which involved three separate scenarios, was conducted at Idaho National Engineering Laboratory (INEL). The participants included representatives from SNL, LLNL, PNL, and INEL. DOE has selected INEL

as the long term testbed for MIMS developed sensors, systems, and scenarios.

This paper will describe the installation, intended purpose, and results of the field demonstrations at LLNL and INEL under the MIMS program.

Introduction

The Modular Integrated Monitoring System (MIMS) program is funded under the Department of Energy (DOE), NN-20 program office. Funding was provided to support two separate field demonstrations: one at the LLNL Hardened Engineering Test Building (HETB) within the "Super Block" plutonium facility and a second at the INEL Idaho Chemical Processing Plant (ICPP). The INEL location has also been designated by the DOE as the long term testbed for future field tests and/or demonstrations of MIMS related sensors and scenarios.

The purpose of the field tests were to demonstrate capabilities/features of the MIMS modular architecture/network - integration of multiple sensors (laboratory developed and commercial), secure/encrypted remote monitoring capability, RF and wired local authenticated communications, data display, data logging, data fusion, rapid response, and data analysis.

The field exercise at the LLNL facility was titled the Item Tracking and Transparency (IT&T) demonstration. The primary objective of the demonstration was to showcase to agencies and individuals involved in areas of nonproliferation

DISCLAIMER

This report was prepared as an account of work sponsored by an agency of the United States Government. Neither the United States Government nor any agency thereof, nor any of their employees, make any warranty, express or implied, or assumes any legal liability or responsibility for the accuracy, completeness, or usefulness of any information, apparatus, product, or process disclosed, or represents that its use would not infringe privately owned rights. Reference herein to any specific commercial product, process, or service by trade name, trademark, manufacturer, or otherwise does not necessarily constitute or imply its endorsement, recommendation, or favoring by the United States Government or any agency thereof. The views and opinions of authors expressed herein do not necessarily state or reflect those of the United States Government or any agency thereof.

DISCLAIMER

Portions of this document may be illegible in electronic image products. Images are produced from the best available original document.

and national security current US technological capabilities that support transparency and confidence building measures. The IT&T also demonstrated the ability to remotely monitor, via satellite, declared nuclear items in a non-intrusive, transparent fashion. The IT&T demonstration included near real-time video monitoring from five different cameras, which allowed for visual confirmation of the item tracking scenario.

The primary purpose of the field test at the ICPP was to establish an operational system at the DOE MIMS testbed. As new and/or improved sensors and data acquisitions displays are developed, the testbed will provide a method in which to field test these new developments. Also, different monitoring scenarios can be developed and demonstrated at the testbed. Another objective at the ICPP demonstration was rapid deployment of a MIMS based monitoring system for three mini-scenarios - 1) effluent stack monitoring, 2) sensor data fusion for vehicle portal monitoring, 3) intrusion alarms fused with nuclear radiation detection through a pedestrian portal.

The INEL field test also demonstrated remote monitoring capabilities, including digital video images, via commercial telephone lines. The remote station was installed in an INEL facility lab in Idaho Falls.

LLNL IT&T Field Test Description

A block diagram of the sensors integrated onto the MIMS network is shown in figure 1. The block diagram does not show the video configuration, which was a major component of the demonstration. Figure 2 shows the location of the sensors inside the "Super Block" facility and the path that was taken by the vehicle which carried the monitored items. The sensitive items that were monitored/tracked were located inside a walk-in environmental chamber which is inside the HETB building.

Sensor Location and Description

The following describes sensor location and intended purpose of each particular sensor. Six sensors were located inside the environmental chamber. The chamber contained two declared items and two isotopic radiation sources. Each of the declared items had an LLNL electronic fiber optic loop seal and an SNL RF fiber optic seal attached to it. Also, two SNL RF motion sensors were mounted on the sensitive items. Utilization of these sensors allowed for monitoring of "declared" items only. Items that do not have sensors attached are undeclared and therefore not monitored.

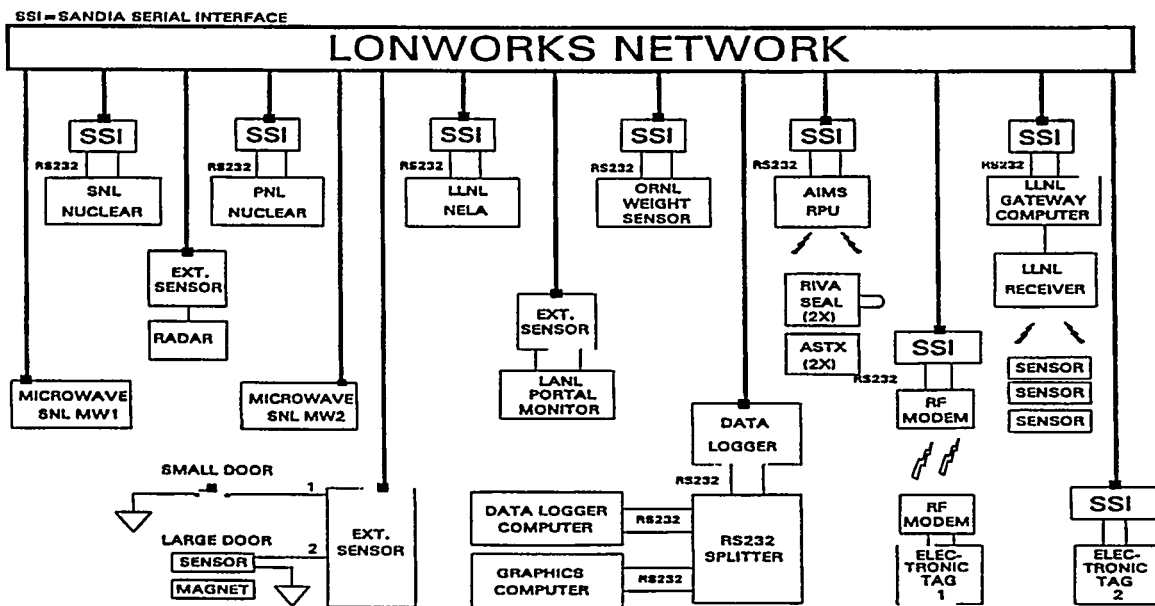

Figure 1 : Item Tracking & Transparency Sensor Block Diagram

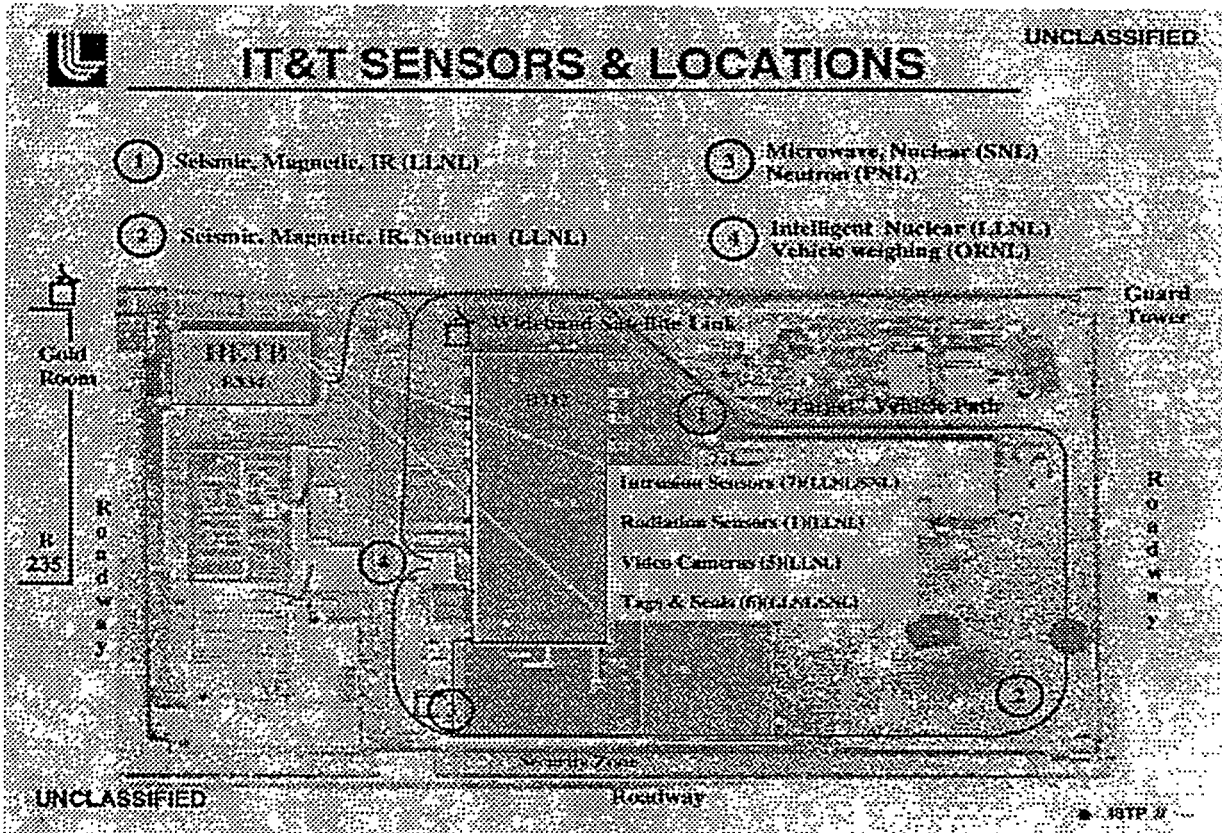

Figure 2 : Vehicle Path Inside the Super Block facility

The environmental chamber door switch along with the large HETB building bay doors, which contained a magnetic door alarm, were monitored for intrusion. The MIMS network prevented sensor reporting until the opening of either door was detected, at which time the network allowed sensor data to be reported to the data acquisitions displays. This simulated a system in transparency until an activity of interest is detected.

The following sensors were located inside the HETB building: an LLNL radar motion sensor, an LLNL radiation sensor, for detecting the items of interest, and an LANL personnel portal monitor with integrated radiation detector and infrared motion detector. The aforementioned sensors were used to detect activity and radiation sources within the building.

The following sensors were located outside of the building but within the "Super Block" facility and along the designated roadway (see figure 2): LLNL unattended RF ground sensors - seismic,

magnetic, and IR (at two separate locations), an LLNL neutron detector, a PNL neutron detector, an SNL nuclear detector and two microwave motion sensors, an ORNL weigh-in-motion sensor, and LLNL intelligent nuclear sensor. Data from the sensors were used to "track" the vehicle along the roadway. The tracking of the vehicle and sensor activation were displayed in real-time on the LLNL graphical display system.

An auxiliary system contained five video cameras - one inside the environmental chamber, one inside the HETB building, and three cameras outside that allowed for near real-time viewing of the activity inside the HETB building and along the roadway. The camera images were updated approximately every 4 seconds and were simultaneously displayed during the demonstration.

Test Plan of Item Tracking and Transparency Scenario

The test plan called for a demonstration of transparency, ignoring normal activity at a facility, and the capability to remotely monitor the movement (tracking) of "declared items". Transparency was demonstrated when the MIMS network prevented sensor data from arriving at the data display/acquisition systems until the HETB was entered through the monitored door. For the demonstration, the activity which commenced the "tracking" of the declared items was the opening of either the environmental chamber door or the HETB bay doors. The MIMS network could have easily been programmed for any other sensor or suite of sensors to provide the trigger for starting and stopping the tracking scenario.

The test plan called for two declared items and two nuclear sources, which simulated non-declared items, to be stored inside the environmental chamber. The following is quick synopsis of the complete field test.

- Movement of non-declared items and other activities, both within the HETB building and along the declared roadway, are not recorded by MIMS.
- The HETB bay doors are opened, all sensors begin reporting.
- Seals are removed from declared items.
- Declared items are detected by HETB radiation and motion sensors.
- Declared items are loaded onto a vehicle.
- Vehicle begins travel along specified roadway and is detected at sensor station 1.
- Vehicle is then detected at sensor station 2 - Nuclear detection also occurs.
- Vehicle and nuclear detection is also detected at sensor station 3.
- Vehicle arrives at simulated choke point and one of two declared items is removed, vehicle weighing and intelligent nuclear measurement occurs at station 4.
- Non-declared items are loaded onto a second vehicle, which travels the identical path.
- Second vehicle passes first vehicle at choke point and returns non-declared items to storage (simulates movement of non-declared items).
- First vehicle travels along roadway a second time with only one declared item and returns the item to storage and seals are reapplied.
- All doors are closed, system returns to stand-by, and first vehicle travels around roadway a third time.

Field Test Objectives and Results

The main objective was to demonstrate MIMS capabilities -- which included remote monitoring/tracking of declared items, multi-sensor compatibility, non-intrusiveness to normal activity (transparency), data collection and display, and data fusion, to support transparency and confidence building measures. Some additional objectives were also satisfied during the field test: 1) demonstrated the cooperation between DOE labs, 2) monitoring of declared items in a secure facility, 3) differentiate between declared and non-declared item movements, 4) real-time and archived data reporting.

The sensor data was available and displayed in real-time on the LLNL graphical display system and archived on the SNL data acquisition system for detailed review/analysis at a later time. The video data was displayed in near real-time and also archived on video recorders for playback at a later time. Analysis of both the real-time and archived data indicated that the demonstration was a complete success. All the sensors detected/activated as expected and the data from the sensors traveled flawlessly on the MIMS network. For test purposes, an additional SNL data acquisition system was attached to the network in parallel with the satellite feed. This allowed for comparison of the data before and after the satellite transmission. Only one of hundreds of data packets failed to arrive at the receive end of the satellite transmission.

INEL ICPP Field Test Description

A block diagram of the sensors utilized during the initial configuration of an operational system at the INEL MIMS testbed is shown in figure 3. The main objective of the ICPP installation and demonstration was to establish the MIMS long-term testbed. The field test also allowed for demonstration of some current capabilities of the MIMS system: 1) rapid deployment (less than two working days were required for system installation and verification), 2) modularity (three different mini-monitoring scenarios were demonstrated) 3) common data path with data authentication - MIMS network, 4) utilization of existing facility infrastructure

- ICPP cameras, outdoor microwave sensor, magnetic door sensor, and cabling were used, 5) utilization of sensors currently compatible with network, 6) remote monitoring of sensor data and video images.

SSI = SANDIA SERIAL INTERFACE

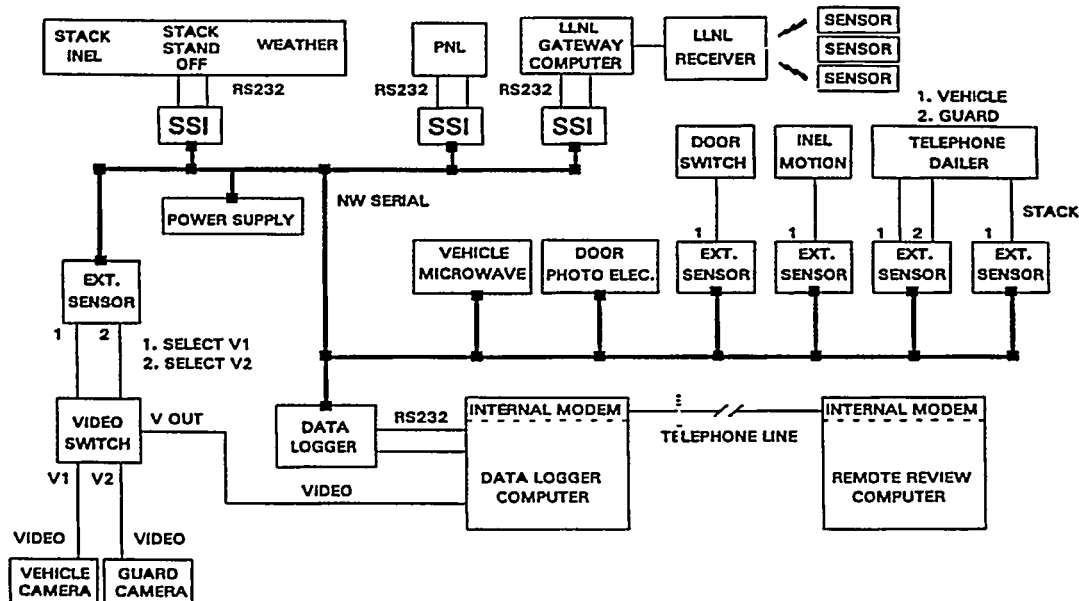

Figure 3 : MIMS INEL Sensor Block Diagram

Monitoring Scenarios

Three mini-scenarios were developed to demonstrate the capability of the MIMS network to adapt to the required monitoring application. The following is a description of the scenarios and their intended purpose:

1) Vehicle detection at a facility entrance:

The roadway leading to the entrance was monitored with LLNL unattended RF ground sensors -- seismic, magnetic, and IR. A commercial microwave sensor mounted inside of an SNL network enclosure was positioned at the roadway intersection leading to the entrance. An ICPP security motion sensor, which was located at the simulated vehicle gate entrance, was also integrated into the network. The existing security camera's field of view covered the simulated gate entry point.

Data from the sensors described above were fused to determine if a vehicle had traveled the monitored roadway leading to the entrance to the facility. Upon determining that a vehicle was approaching the entrance, the network would select the vehicle camera (see figure 4) and the camera image would be captured and stored by the digital capture and compression board mounted inside the

SNL Data Acquisition System (DAS). The network would also trigger a commercial telephone auto-dialer device, which was programmed to call a simulated security guard number. This feature simulated a real-time response to an alarm condition.

2) Sensitive Nuclear Materials (SNM) and Personnel Detection

A scenario was developed to simulate the detection of site personnel or any individual attempting to smuggle SNM outside of the monitored area. An existing personnel portal inside of the vehicle monitoring building was used for the demonstration. An existing security door alarm and a commercial photo-electric break beam sensor, mounted inside of an SNL network enclosure, were used to detect entry into the hallway leading to the personnel portal. The PNL radiation sensor, which was positioned near the portal, was used to detect radiation sources.

A sequence of alarms from the door, photo-electric, and radiation sensors would cause the DAS to capture an image from the existing indoor/portal camera (see figure 5). As in the previous scenario, the network would also trigger the telephone auto-dialer.

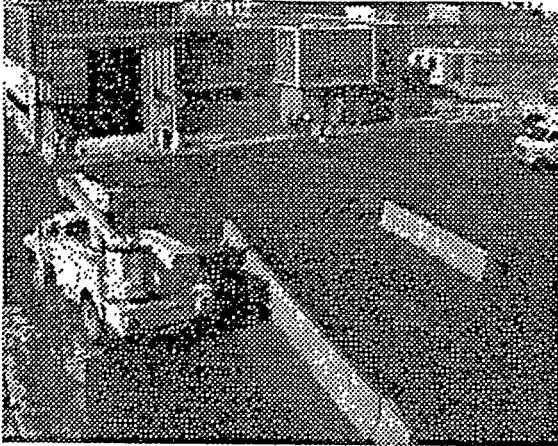

Figure 4 : Vehicle Camera Field of View

3) Stack Effluent Monitoring Scenario

Because of time constraints and ICPP plant requirements, the actual use of the in-place stack effluent sensors and extraction of existing ICPP meteorological data was not possible. Previous stack data from the plant computers were installed on a laptop computer and were formatted to be compatible with the DAS software. Thus, for the demonstration, the simulated stack data were displayed only on the laptop PC. The scenario called for the network to trigger the telephone auto-dialer if predetermined stack or weather data points were exceeded.

Field Test Objectives and Results

The demonstration was a success in that the system operated according to the predefined scenarios. Captured images and telephone dialouts all occurred at the appropriate times. The DAS contained an internal telephone modem with appropriate software that allowed for remote interrogation by the Data and Image Review Station (DIRS), which was located in an INEL lab in Idaho Falls.

The field test concluded with a trip back to Idaho Falls to review the data they were collected during the demonstration. Utilizing the DIRS, data were remotely transferred to Idaho Falls. Each image that was related to the vehicle detection scenario contained a vehicle in the image. Because of the field of view of the indoor personnel portal camera, the image of the person in the portal was barely visible.



Figure 5 : Personnel Portal Field of View

The main objectives for the field test were also satisfied: 1) deployment of an operational, MIMS compatible, monitoring system at the DOE testbed 2) rapid deployment 3) modularity 4) data authentication 5) utilization of existing facility infrastructure 6) usage of MIMS compatible sensors, 7) remote monitoring 8) application/scenario independent.

Acknowledgments

The authors of this paper would like to thank the personnel at LLNL and INEL for their efforts during the installation activities that were required for the demonstrations. A special acknowledgment for R. Guyton (LLNL) is in order, for his coordination of the installation activities for the large IT&T demonstration.

References

B. Wheeler - LLNL, D. Waymire - SNL; Item & Tracking & Transparency (IT&T) Field Exercise and Demonstration Plan, October 17, 1994 Issue E.

D. Waymire, R. Martinez - SNL, E. Filby - INEL, D. Meyers, B. Wheeler - LLNL, J. Abraham - PNL; Final Report: FY94 Field Test of MIMS LonWorks Subsystem Capability at INEL, December 19, 1994

The work in paper was supported by the United States Department of Energy under Contract DE-AC04-94AL85000.