

**OFFICE OF CIVILIAN RADIOACTIVE WASTE MANAGEMENT
CALCULATION COVER SHEET**

1. QA: QA



Page: 1 Of: 12

2. Calculation Title
Vertical Drop of the Naval SNF Long Waste Package on Unyielding Surface

3. Document Identifier (including Revision Number)
CAL-VDC-ME-000002 REV 00

4. Total Attachments
3

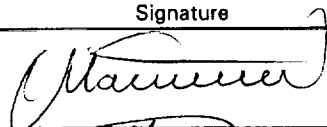
5. Attachment Numbers - Number of pages in each
I-3, II-2, III-7

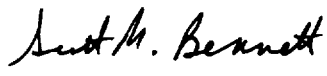
	Print Name	Signature	Date
6. Originator	Sreten Mastilovic		02/10/2000
7. Checker	Bradford A. Colton		02/11/2000
8. Lead	Scott M. Bennett		02/11/00

9. Remarks

Revision History

10. Revision No.	11. Description of Revision
00	Initial issue

CONTENTS

	Page
1. PURPOSE.....	3
2. METHOD	3
3. ASSUMPTIONS.....	3
4. USE OF COMPUTER SOFTWARE AND MODELS	5
4.1 SOFTWARE APPROVED FOR QUALITY ASSURANCE (QA) WORK.....	5
4.2 SOFTWARE ROUTINES	5
4.3 MODELS	5
5. CALCULATION.....	6
5.1 MATERIAL PROPERTIES	6
5.2 CALCULATIONS FOR TANGENT MODULI	7
5.3 MASS AND GEOMETRIC DIMENSIONS OF NAVAL SNF CANISTER.....	7
5.4 FINITE ELEMENT REPRESENTATION	8
6. RESULTS	9
7. ATTACHMENTS.....	10
8. REFERENCES	11

1. PURPOSE

The purpose of this calculation is to determine the structural response of a Naval SNF (Spent Nuclear Fuel) Long Waste Package (WP) subjected to 2 m-vertical drop on unyielding surface (US). The scope of this document is limited to reporting the calculation results in terms of maximum stress intensities. This calculation is associated with the waste package design; calculation is performed by the Waste Package Design group. AP-3.12Q, Revision 0, ICN 0, *Calculations*, is used to perform the calculation and develop the document.

2. METHOD

The finite element calculation is performed by using the commercially available ANSYS Version (V) 5.4 finite element code. The result of this calculation is provided in terms of maximum stress intensities.

3. ASSUMPTIONS

In the course of developing this document, the following assumptions are made regarding the WP structural calculations.

- 3.1 Some of the temperature-dependent material properties are not available for SB-575 N06022 (Alloy 22), SA-240 S31600 (316NG [nuclear grade] stainless steel [SS]), and SA-240 S31603 (316L SS). Therefore, room-temperature (20 °C) material properties are assumed for all materials. The impact of using room-temperature material properties is anticipated to be small. The basis for this assumption is that the mechanical properties of said materials do not change significantly at the temperatures experienced during handling and lifting operations. This assumption is used in Section 5.1.
- 3.2 Some of the rate-dependent material properties are not available for the materials used. Therefore, the material properties obtained under the static loading conditions are assumed for all materials. In general, this is notably conservative assumption, nonetheless, in this case, the impact of using material properties obtained under the static loading conditions is anticipated to be small. The basis for this assumption is that the mechanical properties of subject materials do not significantly change at the peak strain rates in the course of the 2 m-vertical drop. This assumption is used in Section 5.1.
- 3.3 The magnitudes of contact stiffnesses between the WP and the US, the closure lid and the inner-lid lifting feature, and the outer lid and the closure-lid lifting feature are assumed to be $6 \cdot 10^{10} \text{ N/m}$. The basis for this assumption is explained below:

- The magnitude of the contact stiffness between surfaces is one of the parameters that affects the results. If the contact stiffness value is very large, stiffness matrix ill-conditioning and divergence occur. On the other hand, extremely small contact stiffness value results in compatibility violations. Therefore, an optimum value for the contact stiffness is one that is in between and is arrived at iteratively. The iterative procedure is based on engineering judgement and supported by the ANSYS V5.4 on-line help. It should be noted that the contact stiffness is neither a measurable nor an intrinsic property of the materials in contact. This assumption is used in Section 5.4.
- 3.4 The Poisson's ratio of Alloy 22 is not available in literature. Therefore, the Poisson's ratio of Alloy 625 (SB-443 N06625) is assumed for Alloy 22. The impact of this assumption is anticipated to be negligible. The basis for this assumption is that the chemical compositions of Alloy 22 and Alloy 625 are similar (see Ref. 4, Table 1 and Ref. 5, p. 143, respectively). This assumption is used in Section 5.1.
 - 3.5 The inner and outer WP shells are assumed to have solid connections at the adjacent surfaces. The basis for this assumption is that the shells will be assembled by shrink fit (Ref. 6, p. 21), thus it is reasonable to assume solid contact between the shells. This assumption is used in Section 5.4.
 - 3.6 The target surface is conservatively assumed to be essentially unyielding by using a large elastic modulus for the target surface compared to the waste package. The basis for this assumption is that a bounding set of results is required in terms of stresses and it is known that the use of an essentially unyielding surface ensures slightly higher stresses in the WP. This assumption is used in Section 5.4.
 - 3.7 The exact geometry of the Naval SNF canister is simplified for the purpose of this calculation in such a way that its total mass, 44452 kg (see Section 5.3), is assumed to be distributed within a cylinder of circular cross section and uniform mass density. This assumption slightly increases the bending moment acting on the weld joining the lower inner shell lid and the inner shell. The basis for this conservative assumption is to provide the set of bounding results, while simplifying the finite element representation (FER). This assumption is used in Section 5.4.
 - 3.8 The Poisson's ratio of 316L SS is not available in literature. Therefore, the Poisson's ratio of 316 SS (SA-240 S31600) is assumed for 316L SS. The impact of this assumption is anticipated to be negligible. The basis for this assumption are the similar chemical compositions of these two stainless steels (see Ref. 9, Table 1). This assumption is used in Section 5.1.

4. USE OF COMPUTER SOFTWARE AND MODELS

4.1 SOFTWARE APPROVED FOR QUALITY ASSURANCE (QA) WORK

The finite element analysis computer code used for this calculation is ANSYS V5.4 that is identified by the Computer Software Configuration Item (CSCI) 30040 V5.4 and was obtained from Software Configuration Management in accordance with appropriate procedures. ANSYS V5.4 is a commercially available finite element analysis code and is appropriate for structural calculations of waste packages as performed in this calculation. The calculation using the ANSYS V5.4 software was executed on the Hewlett-Packard (HP) workstation identified with Civilian Radioactive Waste Management System (CRWMS) Management and Operating Contractor (M&O) tag number 115288. The software qualification of the ANSYS V5.4 software is summarized in the Software Qualification Report for ANSYS V5.4 (Ref. 1). Qualification of ANSYS V5.4 on the Waste Package Operations (WPO) HP UNIX workstations is documented in Reference 2. The ANSYS evaluation performed for this design is fully within the range of the validation performed for the ANSYS V5.4 code. Access to the code was granted by the Software Configuration Secretariat in accordance with the appropriate procedures.

4.2 SOFTWARE ROUTINES

None used.

4.3 MODELS

None used.

5. CALCULATION

5.1 MATERIAL PROPERTIES

Material properties used in the calculations are listed in this section. Some of the temperature-dependent and rate-dependent material properties were not available for Alloy 22 and 316NG SS; therefore, room-temperature material properties obtained under the static loading conditions were used in calculations (Assumptions 3.1 and 3.2).

SB-575 N06022 (ASTM B 575) (Alloy 22) (Outer shell, outer shell lids, extended outer shell lid base, outer shell lifting features, upper and lower trunnion collar sleeves, and inner shell support ring):

- Density = 8690 kg/m^3 (0.314 lb/in^3) (Ref. 4, p. 2)
- Yield strength = 310 MPa (45 ksi) (Ref. 4, Table 3)
- Tensile strength = 690 MPa (100 ksi) (Ref. 4, Table 3)
- Elongation = 0.45 (Ref. 4, Table 3)
- Poisson's ratio = 0.278 (Ref. 5, p. 143; see Assumption 3.4)
- Modulus of elasticity = 206 GPa ($29.9 \cdot 10^6 \text{ psi}$) (Ref. 7, p. 14)

SA-240 S31600 (316NG SS, which is 316 SS with tightened control on carbon and nitrogen content and has the same material properties as 316 SS [see Ref. 3]) (Inner shell, inner shell lids, and inner shell lifting feature):

- Density = 7980 kg/m^3 (Ref. 10, p. 7)
- Yield strength = 205 MPa (30 ksi) (Ref. 9, Table 2)
- Tensile strength = 515 MPa (75 ksi) (Ref. 9, Table 2)
- Elongation = 0.40 (Ref. 9, Table 2)
- Poisson's ratio = 0.3 (Ref. 5, Figure 15, p. 755)
- Modulus of elasticity = 195 GPa ($28.3 \cdot 10^6 \text{ psi}$) (Ref. 8, Table TM-1)

SA-240 S31603 (316L SS) (Naval SNF canister):

- Poisson's ratio = 0.3 (Ref. 5, Figure 15, p. 755; see Assumption 3.8)
- Modulus of elasticity = 195 *GPa* ($28.3 \cdot 10^6$ *psi*) (Ref. 8, Table TM-1)

5.2 CALCULATIONS FOR TANGENT MODULI

The results of this simulation are required to include elastic and plastic deformations for Alloy 22 and 316NG SS. When the materials are driven into the plastic range, the slope of stress-strain curve continuously changes. Thus, a simplification for this curve is needed to incorporate plasticity into the finite element representation. A standard approximation commonly used in engineering is to use a straight line that connects the yield point and the ultimate tensile strength point of the material. The following parameters will be used in subsequent calculations:

S_y = yield strength

S_u = ultimate tensile strength

e_y = strain corresponding to yield strength

e_u = ultimate elongation (strain corresponding to ultimate tensile strength)

E = modulus of elasticity

E_t = tangent modulus (slope of the stress-strain curve in the plastic region)

In the case of 316NG SS, the strain corresponding to the yield strength is:

$$e_y = S_y / E = 205 \cdot 10^6 / 195 \cdot 10^9 = 1.051 \cdot 10^{-3}$$

Hence, the tangent modulus is:

$$E_t = (S_u - S_y) / (e_u - e_y) = (0.515 - 0.205) / (0.40 - 1.051 \cdot 10^{-3}) = 0.777 \text{ GPa} \text{ (see Section 5.1)}$$

Similarly, for Alloy 22:

$$E_t = (S_u - S_y) / (e_u - e_y) = (0.690 - 0.310) / (0.45 - 0.310/206) = 0.847 \text{ GPa} \text{ (see Section 5.1)}$$

5.3 MASS AND GEOMETRIC DIMENSIONS OF NAVAL SNF CANISTER

This calculation is performed by using the following mass and geometric dimensions of the Naval SNF canister:

Bounding total mass = 44452 kg (49 tons) (Ref. 11, Enclosure 3, p. 2)

Bounding outside diameter = 1.689 m (66.5 in) (Ref. 11, Enclosure 3, p. 2)

Bounding overall length = 5.385 m (212 in) (Ref. 11, Enclosure 3, p. 2)

5.4 FINITE ELEMENT REPRESENTATION

Two-dimensional (2-D) axisymmetric FER is developed for the WP by taking advantage of its axial symmetry (see p. III-1) and using the dimensions provided in Attachment II and Section 5.3. The internal structure of the WP is simplified by reducing the structure of the Naval SNF canister to a cylinder of circular cross section and uniform mass density (Assumption 3.7). The total mass and the geometric dimensions of the canister (see Section 5.3) define this density. The benefit of using this approach is to reduce the computer execution time while preserving all features of the problem relevant to the structural calculation. Furthermore, the inner and outer shells are assumed to have solid connections at the adjacent surfaces. Since these shells will be assembled by shrink fit it is reasonable to assume solid contact between the shells (Assumption 3.5).

The target surface is conservatively assumed to be essentially unyielding by using a large elastic modulus for the target surface compared to the waste package (Assumption 3.6).

Contact elements are used to represent contact between the WP and the US, the closure lid and the inner-lid lifting feature, and the outer lid and the closure-lid lifting feature. The magnitude of the contact stiffness is one of the parameters that affects the results. If the stiffness value is very large, stiffness matrix ill-conditioning and divergence occur. On the other hand, an extremely small stiffness value results in compatibility violations. Having that in mind, an optimum value for the contact stiffness that works best is determined to be $6 \cdot 10^{10} \text{ N/m}$ (see Assumption 3.3).

The mesh of the FER is appropriately generated, and refined in the contact region according to standard engineering practice. Thus, the accuracy and representativeness of the results of this linear calculation are deemed acceptable.

6. RESULTS

In accordance with AP-3.15Q, Revision 1, ICN 0, *Managing Technical Product Inputs*, the following statement is made: "This document and its conclusions may be affected by technical product input information that requires confirmation. Any changes to the document or its conclusions that may occur as a result of completing the confirmation activities will be reflected in subsequent revisions. The status of the input information quality may be confirmed by review of the Document Input Reference System database." Note that in accordance with AP-3.12Q, Revision 0, ICN 0, *Calculations*, calculations shall not provide any conclusions.

The results show that the maximum stress intensities among the waste package Alloy 22 (except for the lower trunnion collar sleeve) and 316NG SS components are 433 *MPa* (see Reference 12, Attachment V, line # 897), and 275 *MPa* (see Reference 12, Attachment V, line # 901), respectively. These stress intensities are less than nine-tenths of the tensile strength for each of the corresponding materials (see Section 5.1). The maximum stress intensity in the lower trunnion collar sleeve in the region of contact with the unyielding surface is 799 *MPa* (see Reference 12, Attachment V, line # 896), which exceeds the tensile strength of Alloy 22. However, the lower trunnion collar sleeve is not part of the containment barrier. It acts as an impact limiter for the containment barrier in this case.

7. ATTACHMENTS

Attachment I (3 pages): Document Input Reference System sheets

Attachment II (2 pages): Design sketches (Naval SNF Long Waste Package Configuration for Site Recommendation [SK-0194 REV 01]; two sheets)

Attachment III (7 pages): Figures obtained from ANSYS V5.4

Attachments IV and V have been moved to Reference 12. The Table 7-1 contains a list of electronic files including names, dates, times and sizes available in that reference (computer diskette). Note that these are no longer attachments to this document; they are listed for information only.

Table 7-1. List of Electronic Files Available in Reference 12

Description	Date	Time	Size
Attachment IV: naVdrop.at4	01/27/2000	10:18 a.m.	541 KB
Attachment V: naVdrop.at5	01/27/2000	10:20 a.m.	40 KB

NOTE: The file sizes may vary with operating system.

8. REFERENCES

1. CRWMS M&O 1998. *Software Qualification Report for ANSYS V5.4, A Finite Element Code*. CSCI: 30040 V5.4. DI: 30040-2003, REV 00. Las Vegas, Nevada: CRWMS M&O. ACC: MOL.19980609.0847.
2. Doering, T.W. 1998. "Qualification of ANSYS V5.4 on the WPO HP UNIX Workstations." Interoffice correspondence from T.W. Doering (CRWMS M&O) to G. Carlisle, May 22, 1998, LV.WP.SMB.05/98-100. ACC: MOL.19980730.0147.
3. Pasupathi, V. 1999. "Waste Package Structural Material." Interoffice correspondence from V. Pasupathi (CRWMS M&O) to T.W. Doering, May 7, 1999, LV.WP.VP.05/99-073. ACC: MOL.19990518.0316.
4. ASTM (American Society for Testing and Materials) B 575-97. 1998. *Standard Specification for Low-Carbon Nickel-Molybdenum-Chromium, Low-Carbon Nickel-Chromium-Molybdenum, Low-Carbon Nickel-Chromium-Molybdenum-Copper and Low-Carbon Nickel-Chromium-Molybdenum-Tungsten Alloy Plate, Sheet, and Strip*. West Conshohocken, Pennsylvania: American Society for Testing and Materials. TIC: 241816.
5. American Society for Metals 1980. *Properties and Selection: Stainless Steels, Tool Materials and Special-Purpose Metals*. Volume 3 of *Metals Handbook*. 9th Edition. Metals Park, Ohio: American Society for Metals. TIC: 209801.
6. CRWMS M&O 1999. *Waste Package Fabrication Process Report*. BBA000000-01717-2500-00010 REV 03. Las Vegas, Nevada: CRWMS M&O. ACC: MOL.19990617.0237.
7. Haynes International 1997. *Hastelloy C-22 Alloy*. Kokomo, Indiana: Haynes International. TIC: 238121.
8. ASME (American Society of Mechanical Engineers) 1995. "Materials." Section II of *1995 ASME Boiler and Pressure Vessel Code*. New York, New York: American Society of Mechanical Engineers. TIC: 245287.
9. ASTM A 240/A 240M-97a. 1997. *Standard Specification for Heat-Resisting Chromium and Chromium-Nickel Stainless Steel Plate, Sheet, and Strip for Pressure Vessels*. West Conshohocken, Pennsylvania: American Society for Testing and Materials. TIC: 239431.
10. ASTM G 1-90 (Reapproved 1999). 1990. *Standard Practice for Preparing, Cleaning, and Evaluating Corrosion Test Specimens*. West Conshohocken, Pennsylvania: American Society for Testing and Materials. TIC: 238771.

11. Naples, E.M. 1999. Thermal, Shielding, and Structural Information on the Naval Spent Nuclear Fuel (SNF) Canister. Letter from E.M. Naples (Department of the Navy) to D.C. Haught (DOE/YMSCO), August 6, 1999, with enclosures. ACC: MOL.19991001.0133.
12. CRWMS M&O 2000. *Electronic Files for Vertical Drop of the Naval SNF Long Waste Package on Unyielding Surface*. CAL-VDC-ME-000002 REV 00. Las Vegas, Nevada: CRWMS M&O. ACC: MOL.20000131.0353.

**OFFICE OF CIVILIAN RADIOACTIVE WASTE MANAGEMENT
DOCUMENT INPUT REFERENCE SYSTEM**

1. Document Identifier No./Rev.: CAL-VDC-ME-000002 Rev. 0			Change: N/A	Title: VERTICAL DROP OF THE NAVAL SNF LONG WASTE PACKAGE ON UNYIELDING SURFACE					
Input Document			4. Input Status	5. Section Used in	6. Input Description	7. TBV /TBD Priority	8. TBV Due To		
2a.	2. Technical Product Input Source Title and Identifier(s) with Version	3. Section					Unqual.	From Unc controlled Source	Un-Confirmed
1	CRWMS M&O 1998. <i>Software Qualification Report for ANSYS V5.4, A Finite Element Code</i> . CSCI: 30040 V5.4. DI: 30040-2003, Rev. 00. Las Vegas, Nevada: CRWMS M&O. ACC: MOL.19980609.0847.	Entire	N/A - Reference Only	4.1	Software qualification report for ANSYS V5.4	N/A	N/A	N/A	N/A
2	Doering, T.W. 1998. "Qualification of ANSYS V5.4 on the WPO HP UNIX Workstations." Interoffice correspondence from T.W. Doering (CRWMS M&O) to G. Carlisle, May 22, 1998, LV.WP.SMB.05/98-100. ACC: MOL.19980730.0147.	Entire	N/A - Reference Only	4.1	Qualification of ANSYS V5.4 on HP UNIX workstations	N/A	N/A	N/A	N/A
3	Pasupathi, V. 1999. "Waste Package Structural Material." Interoffice correspondence from V. Pasupathi (CRWMS M&O) to T.W. Doering, May 7, 1999, LV.WP.VP.05/99-073. ACC: MOL.19990518.0316.	Entire	N/A - Reference Only	5.1	Mechanical properties of the 316NG stainless steel are the same as those for 316 stainless steel	N/A	N/A	N/A	N/A
4	ASTM B 575-97. 1998. <i>Standard Specification for Low-Carbon Nickel-Molybdenum-Chromium, Low-Carbon Nickel-Chromium-Molybdenum, Low-Carbon Nickel-Chromium-Molybdenum-Copper and Low-Carbon Nickel-Chromium-Molybdenum-Tungsten Alloy Plate, Sheet, and Strip</i> . West Conshohocken, Pennsylvania: American Society for Testing and Materials. TIC: 241816.	Table 1	N/A - Accepted Data (Fact)	3	Chemical composition of Alloy 22 (SB-575 N06022)	N/A	N/A	N/A	N/A
		Page 2	N/A - Accepted Data (Fact)	5.1	Density of Alloy 22	N/A	N/A	N/A	N/A
		Table 3	N/A - Accepted Data (Fact)	5.1	Yield strength of Alloy 22	N/A	N/A	N/A	N/A
		Table 3	N/A - Accepted Data (Fact)	5.1	Tensile strength of Alloy 22	N/A	N/A	N/A	N/A
		Table 3	N/A - Accepted Data (Fact)	5.1	Elongation of Alloy 22	N/A	N/A	N/A	N/A

5	American Society for Metals 1980. <i>Properties and Selection: Stainless Steels, Tool Materials and Special-Purpose Metals</i> . Volume 3 of <i>Metals Handbook</i> . 9th Edition. Metals Park, Ohio: American Society for Metals. TIC: 209801.	Page 143	N/A - Accepted Data (Fact)	3	Chemical composition of Inconel 625 (Alloy 625)	N/A	N/A	N/A	N/A
		Figure 15, page 755	N/A - Accepted Data (Fact)	5.1	Poisson's ratio of 316 stainless steel	N/A	N/A	N/A	N/A
		Page 143	N/A - Accepted Data (Fact)	5.1	Poisson's ratio of Alloy 625 assumed for Alloy 22	N/A	N/A	N/A	N/A
6	CRWMS M&O 1999. <i>Waste Package Fabrication Process Report</i> . BBA000000-01717-2500-00010 REV 03. Las Vegas, Nevada: CRWMS M&O. ACC: MOL.19990617.0237.	Page 21	N/A - Reference Only	3	Inner shell fabrication	N/A	N/A	N/A	N/A
7	Haynes International 1997. <i>Hastelloy C-22 Alloy</i> . Kokomo, Indiana: Haynes International. TIC: 238121.	Page 14	N/A - Accepted Data (AMOPE approved)	5.1	Modulus of elasticity of Alloy 22	N/A	N/A	N/A	N/A
8	ASME (American Society of Mechanical Engineers) 1995. "Materials." Section II of <i>1995 ASME Boiler and Pressure Vessel Code</i> . New York, New York: American Society of Mechanical Engineers. TIC: 245287.	Table TM-1	N/A - Accepted Data (Fact)	5.1	Modulus of elasticity of 316 stainless steel	N/A	N/A	N/A	N/A
		Table TM-1	N/A - Accepted Data (Fact)	5.1	Modulus of elasticity of 316L stainless steel	N/A	N/A	N/A	N/A
9	ASTM A 240/A 240M-97a. 1997. <i>Standard Specification for Heat-Resisting Chromium and Chromium-Nickel Stainless Steel Plate, Sheet, and Strip for Pressure Vessels</i> . West Conshohocken, Pennsylvania: American Society for Testing and Materials. TIC: 239431.	Table 2	N/A - Accepted Data (Fact)	5.1	Elongation of 316 stainless steel	N/A	N/A	N/A	N/A
		Table 2	N/A - Accepted Data (Fact)	5.1	Tensile strength of 316 stainless steel	N/A	N/A	N/A	N/A
		Table 2	N/A - Accepted Data (Fact)	5.1	Yield strength of 316 stainless steel	N/A	N/A	N/A	N/A
		Table 1	N/A - Accepted Data (Fact)	3	Chemical compositions of 316 and 316L stainless steels	N/A	N/A	N/A	N/A
10	ASTM G 1-90 (Reapproved 1999). 1990. <i>Standard Practice for Preparing, Cleaning, and Evaluating Corrosion Test Specimens</i> . West Conshohocken, Pennsylvania: American Society for Testing and Materials. TIC: 238771.	Table X1, page 7	N/A - Accepted Data (Fact)	5.1	Density of 316 stainless steel	N/A	N/A	N/A	N/A

11	Naples, E.M. 1999. Thermal, Shielding, and Structural Information on the Naval Spent Nuclear Fuel (SNF) Canister. Letter from E.M. Naples (Department of the Navy) to D.C. Haught (DOE/YMSCO), August 6, 1999, with enclosures. ACC: MOL.19991001.0133.	Enclosure 3, page 2	TBV-4009	5.3	Bounding Naval Canister Weight, Length, and Diameter Limits.	1	X	N/A	N/A
12	CRWMS M&O 2000. <i>Electronic Files for Vertical Drop of the Naval SNF Long Waste Package on Unyielding Surface</i> . CAL-VDC-ME-000002 REV 00. Las Vegas, Nevada: CRWMS M&O. ACC: MOL.20000131.0353.	Entire	N/A - Reference Only	6	Maximum stress intensities in the waste package	N/A	N/A	N/A	N/A

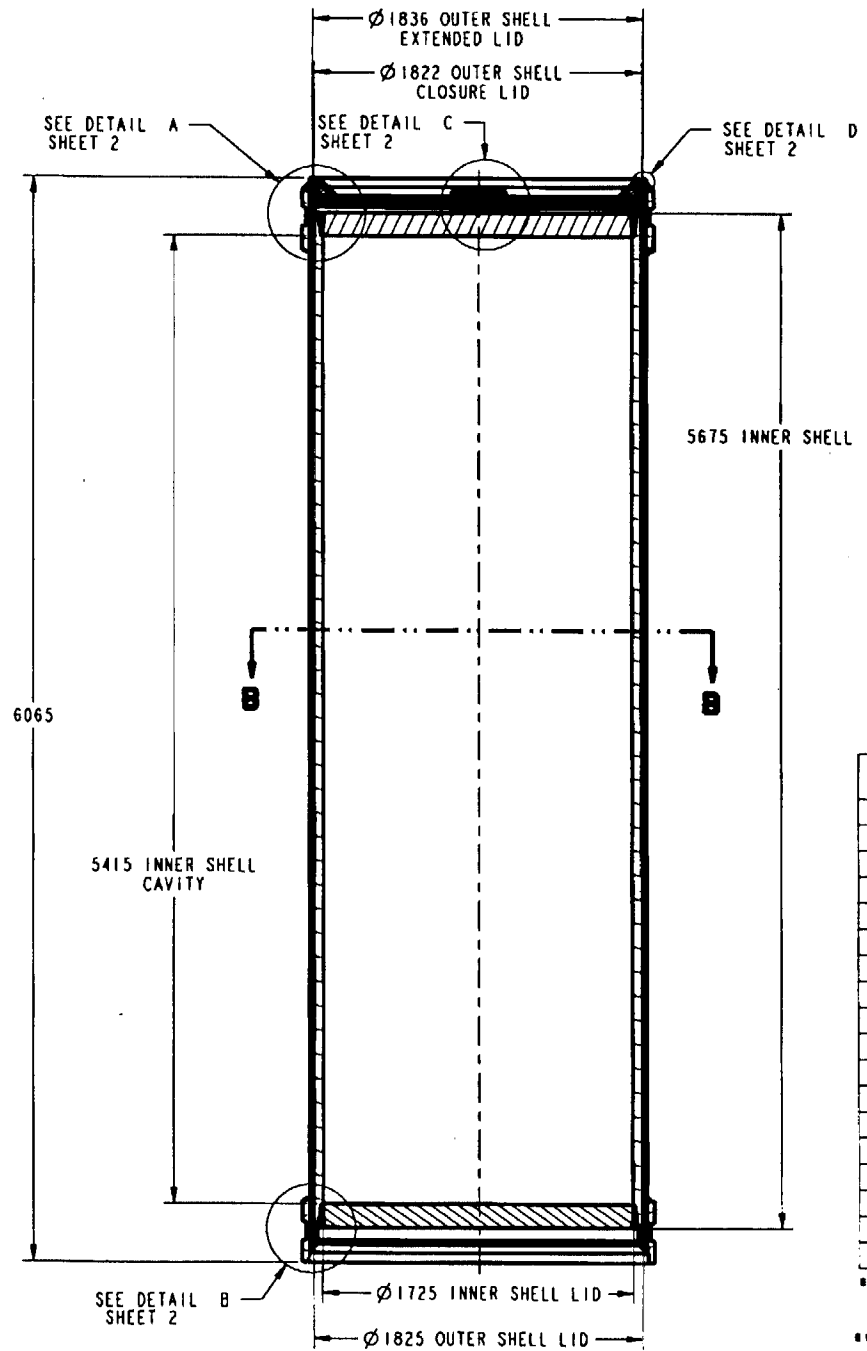
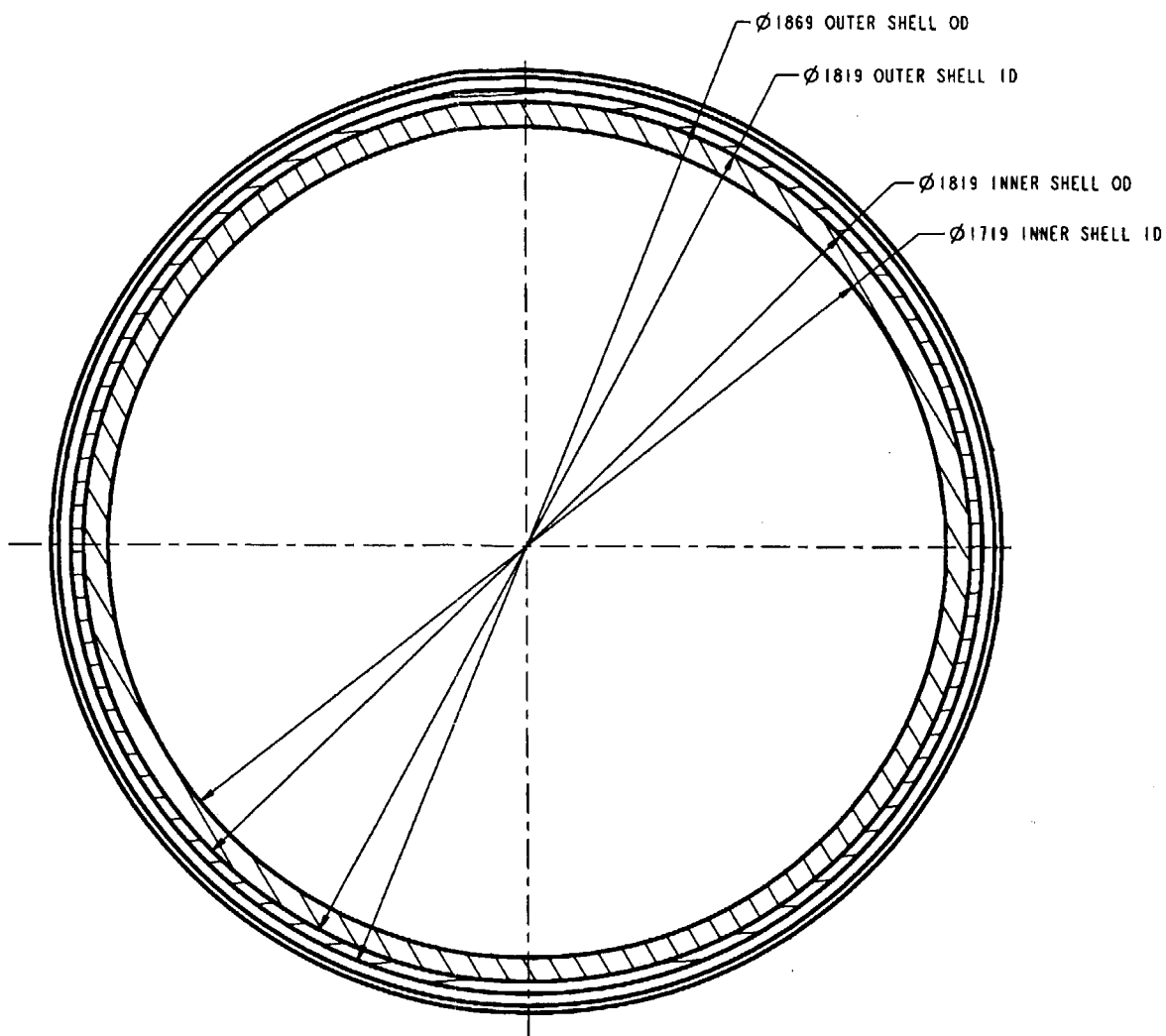
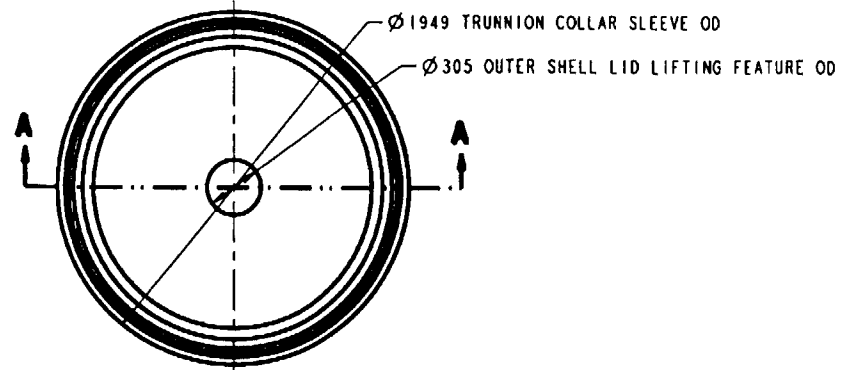

SECTION A-A

SECTION B-B

COMPONENT NAME	MATERIAL	THICKNESS	MASS (KG)	QTY	ROD
INNER SHELL	SA-240 S31600	50	12372	1	
INNER SHELL LID	SA-240 S31600	130	2390	2	
INNER LID LIFTING FEATURE	SA-240 S31600	27	12	1	
OUTER SHELL	SB-575 N06022	25	7430	1	
EXTENDED OUTER SHELL LID	SB-575 N06022	25	158	1	
EXTENDED OUTER SHELL LID BASE	SB-575 N06022	25	528	1	
EXTENDED LID REINFORCEMENT RING	SB-575 N06022	50	118	1	
OUTER LID LIFTING FEATURE	SB-575 N06022	27	13	2	
OUTER SHELL FLAT CLOSURE LID	SB-575 N06022	10	227	1	
OUTER SHELL FLAT BOTTOM LID	SB-575 N06022	25	564	1	
UPPER TRUNNION COLLAR SLEEVE	SB-575 N06022	40	604	1	
LOWER TRUNNION COLLAR SLEEVE	SB-575 N06022	40	592	1	
INNER SHELL SUPPORT RING	SB-575 N06022	20	49	1	
TOTAL ALLOY 22 WELDS	SFA-5.14 N06022	-	298	**	
TOTAL 316 WELDS	SFA-5.9 S31680	-	243	**	
WASTE PACKAGE ASSEMBLY	-	-	28005	1	
NAVAL SNF	-	-	44452*	1	
WASTE PACKAGE WITH SNF	-	-	72457	1	

MAXIMUM EXPECTED PARAMETERS FOR NAVAL REACTORS CANISTERS 10/29/97 FROM: RICHARD GUIDA TO: RUSSELL DYER. MOL.19980121.0011
 **REFER TO SK-0195 REV 00 "NAVAL SNF LONG WASTE PACKAGE WELD CONFIGURATION"

UNITS: mm

DO NOT SCALE FROM SKETCH

"FOR INFORMATION ONLY"

NAVAL SNF LONG WASTE PACKAGE CONFIGURATION FOR SITE RECOMMENDATION

SKETCH NUMBER: SK-0194 REV 01 SHEET 1 OF 2

SKETCHED BY: GENE CONNELL *egc* *SMB*

DATE: 01/11/00 *01/26/00*

FILE: /home/pro_library/checkout/sketches/naaval/naaval snf long/SK-0194.dwg *Jac*

700,2600 *1/24/00*

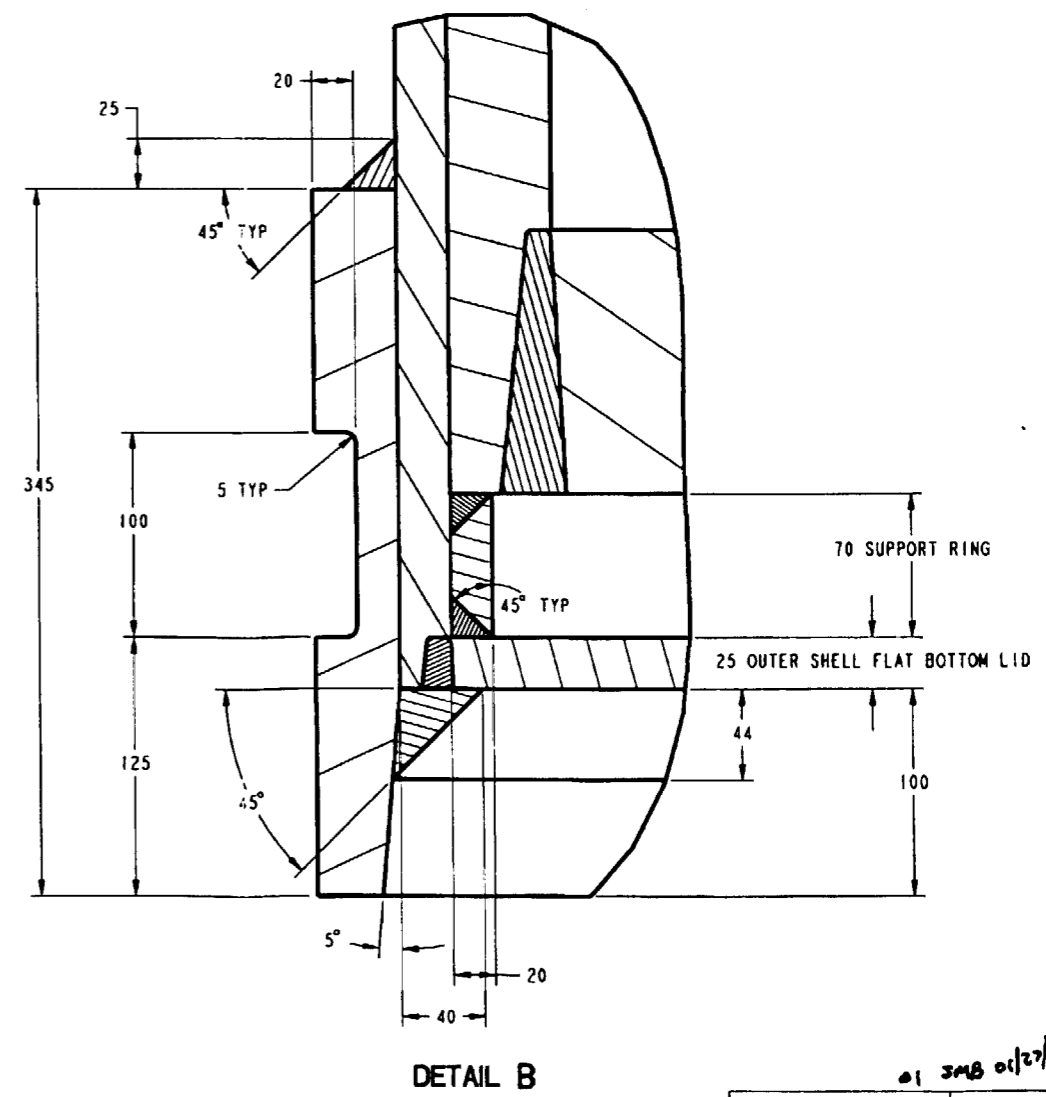
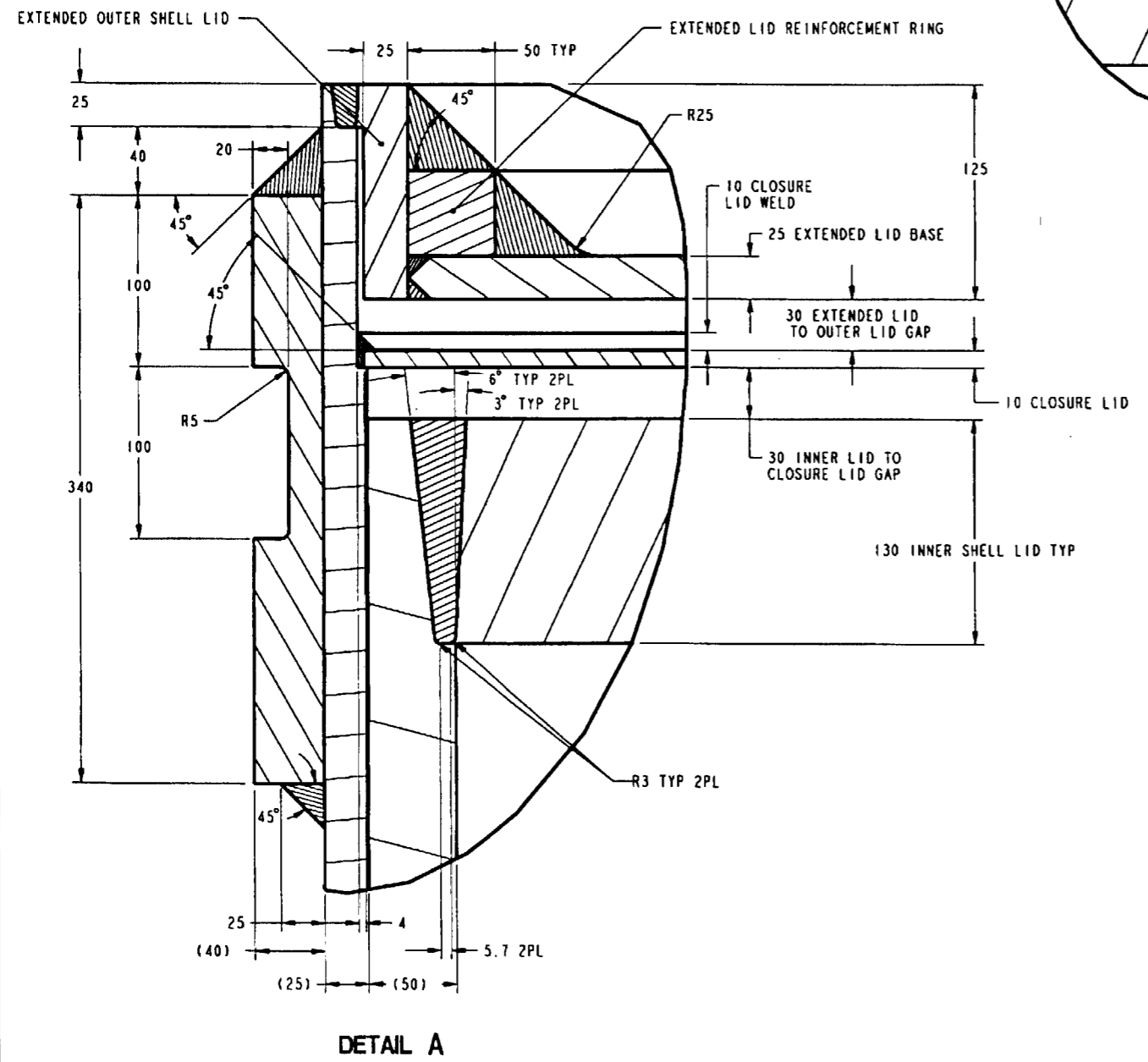
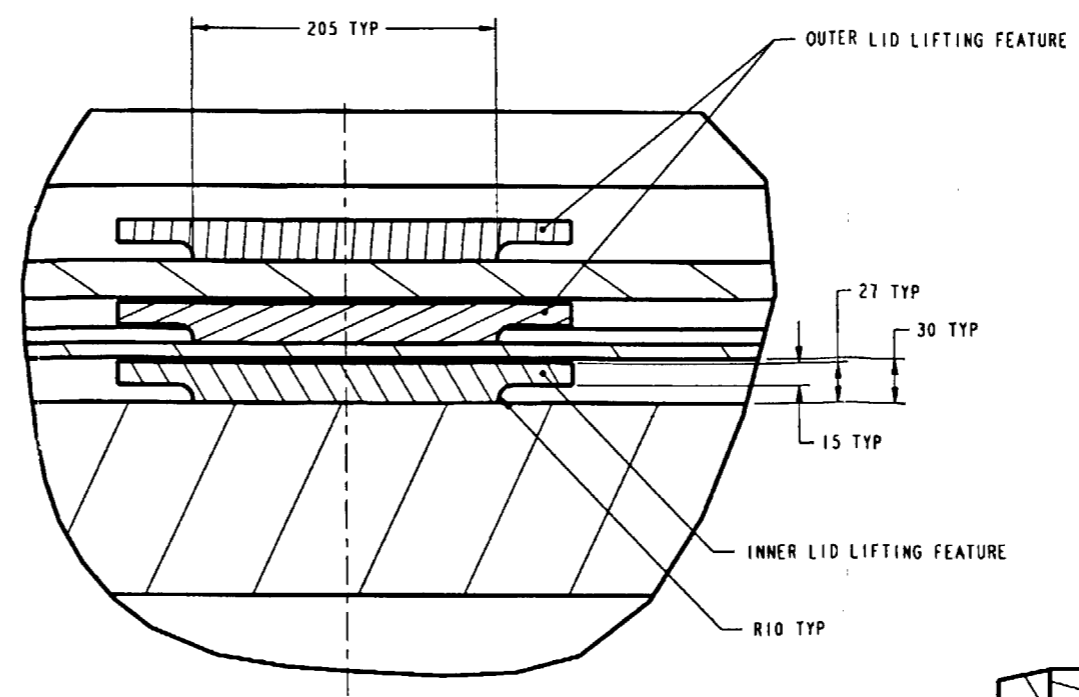
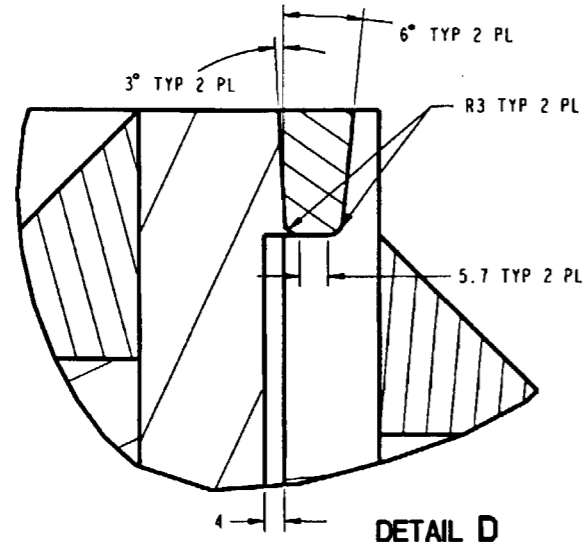

01 SMB 01/27/00
SK-0194 REV 00 SHEET 2 OF 2

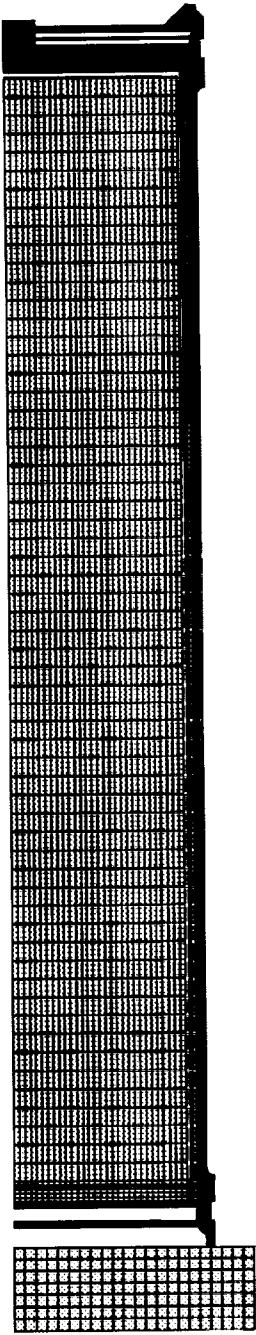

Figure III-1. Finite Element Representation of the Naval Waste Package and Unyielding

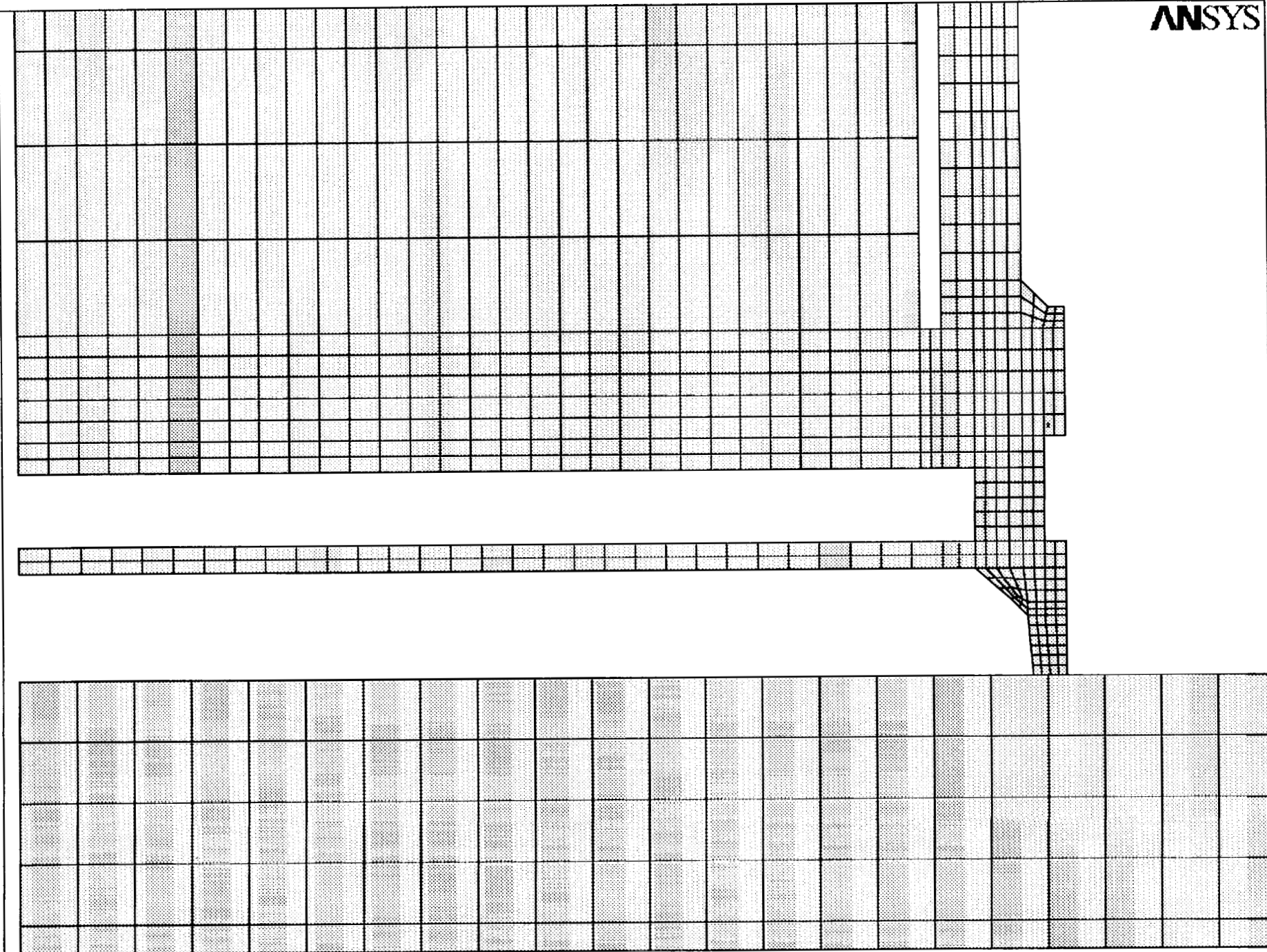

Figure III-2. Contact Zone of the Waste Package and Unyielding Surface

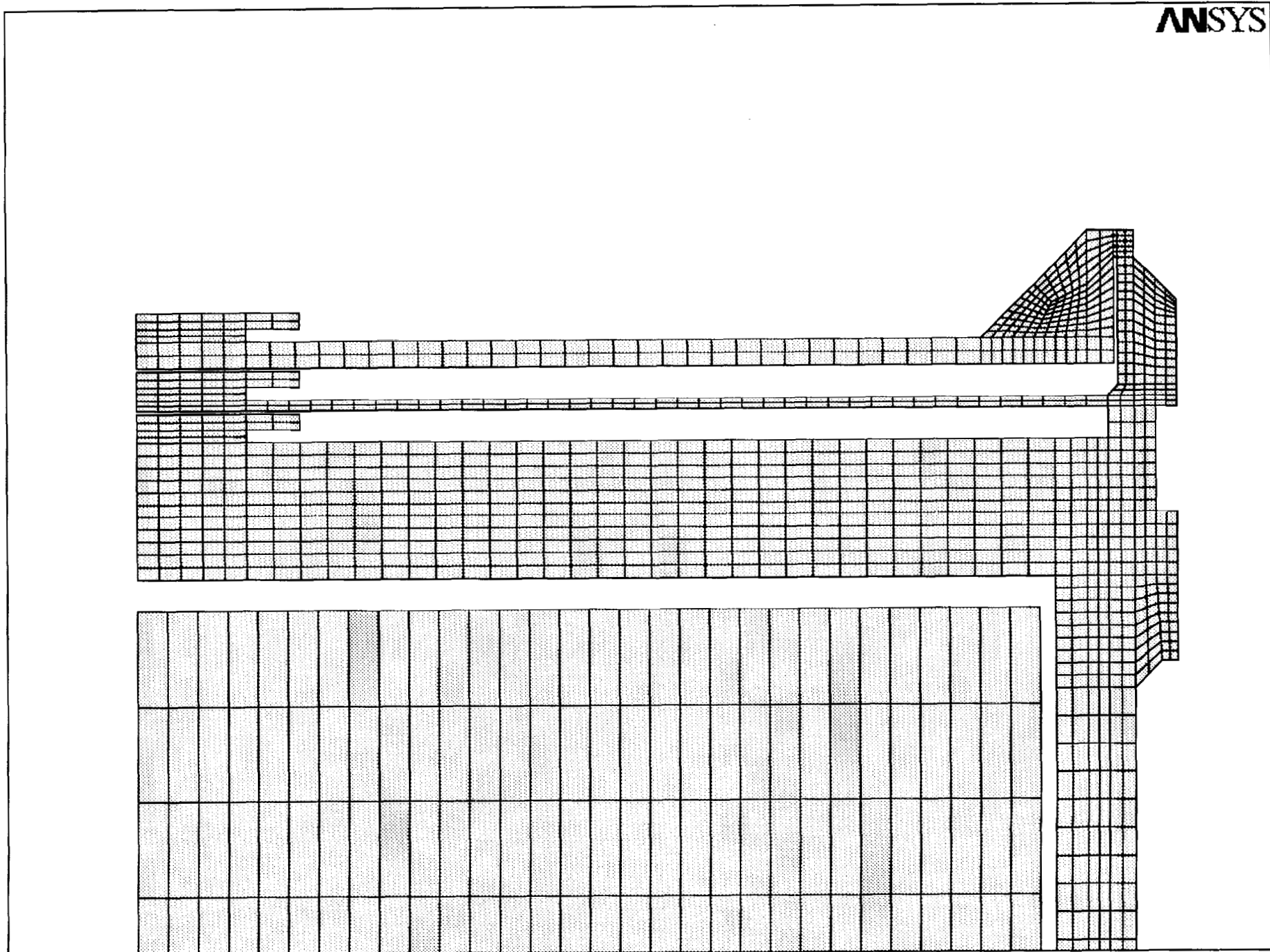

Figure III-3. Detail of the Finite Element Representation of the Upper Section of Waste Package

ANSYS 5.4

NODAL SOLUTION

TIME=.008058
SINT (Pa)

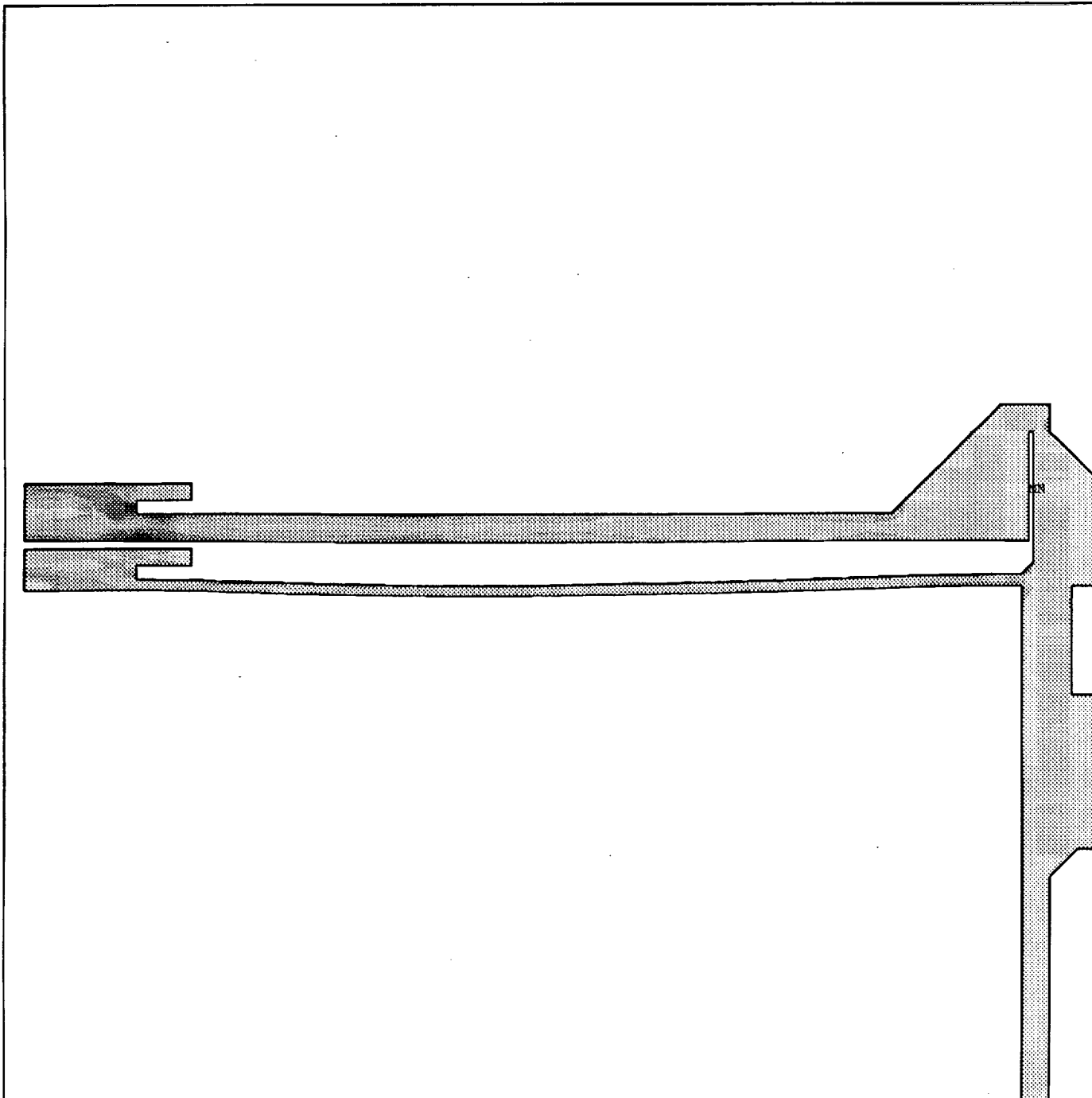
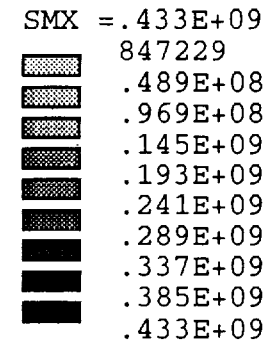

Figure III-4. Stress Intensity Plot for the Alloy 22 Components of the Waste Package (except for Lower Trunnion Collar Sleeve)

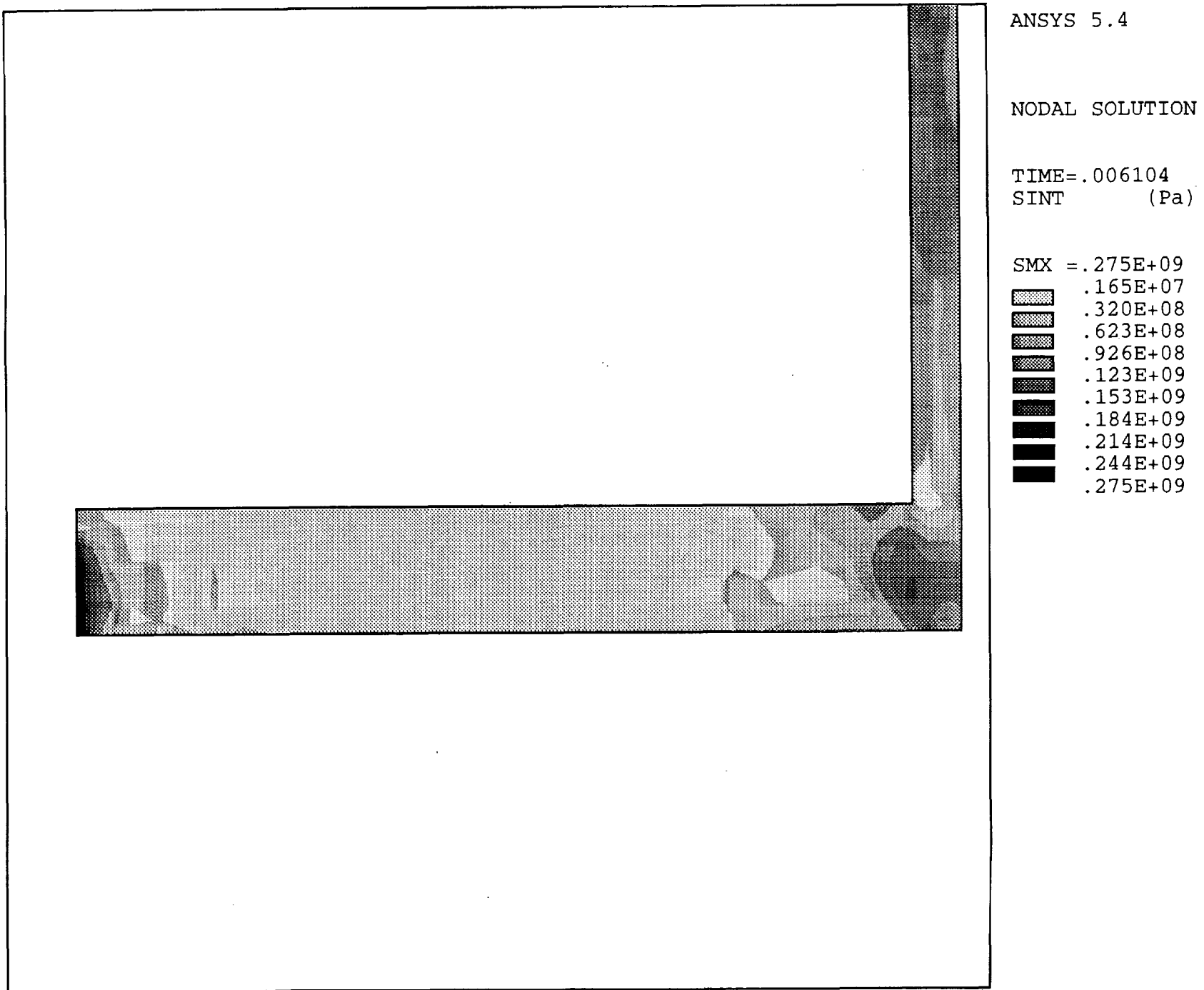
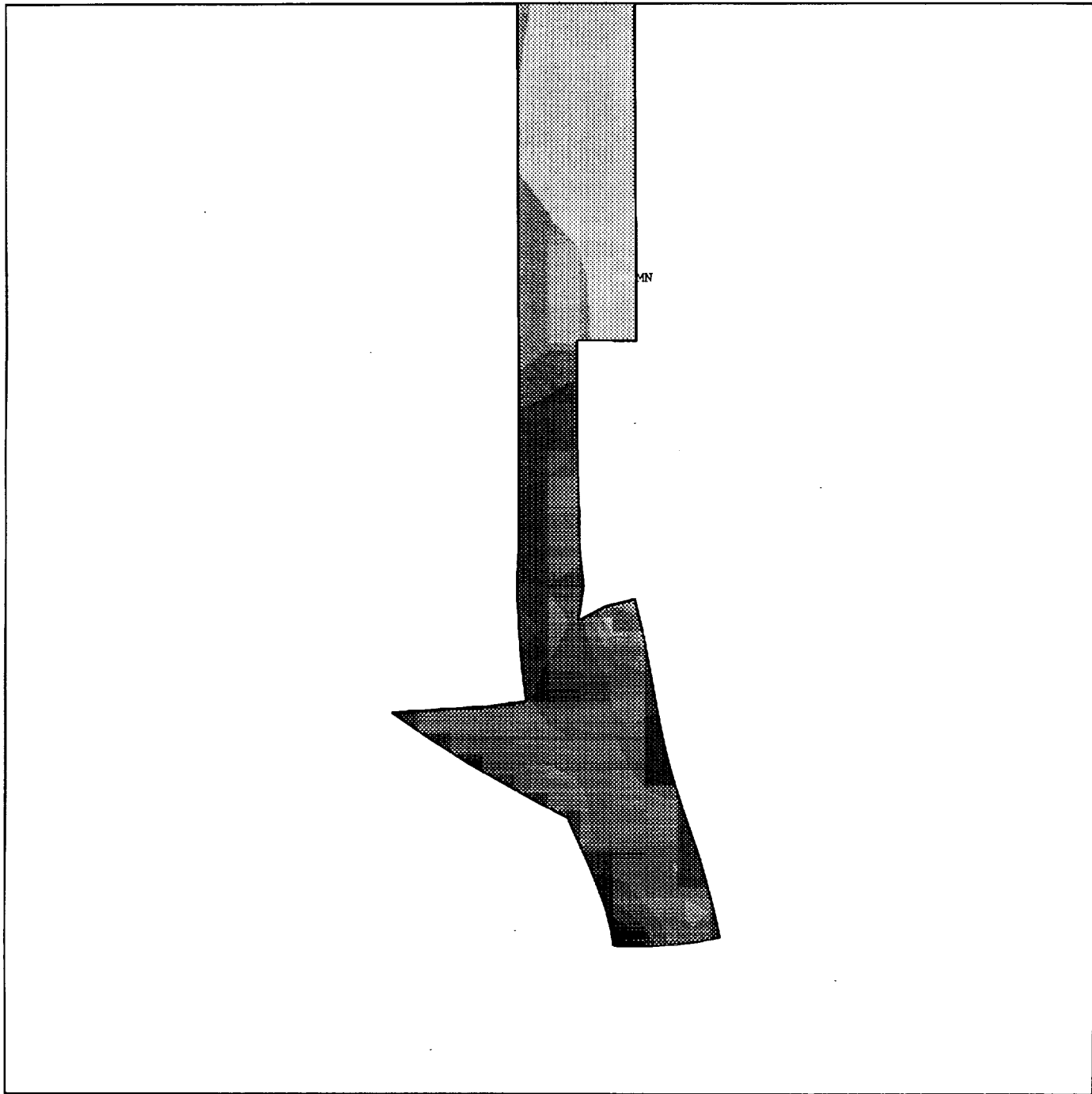

Figure III-5. Stress Intensity Plot for the 316NG SS Components of the Waste Package



ANSYS 5.4

NODAL SOLUTION

TIME=.006444
SINT (Pa)

SMX = .799E+09

■	.639E+07
■	.944E+08
■	.182E+09
■	.270E+09
■	.358E+09
■	.446E+09
■	.534E+09
■	.622E+09
■	.711E+09
■	.799E+09

Figure III-6. Stress Intensity Plot for Lower Trunnion Collar Sleeve (Alloy 22)

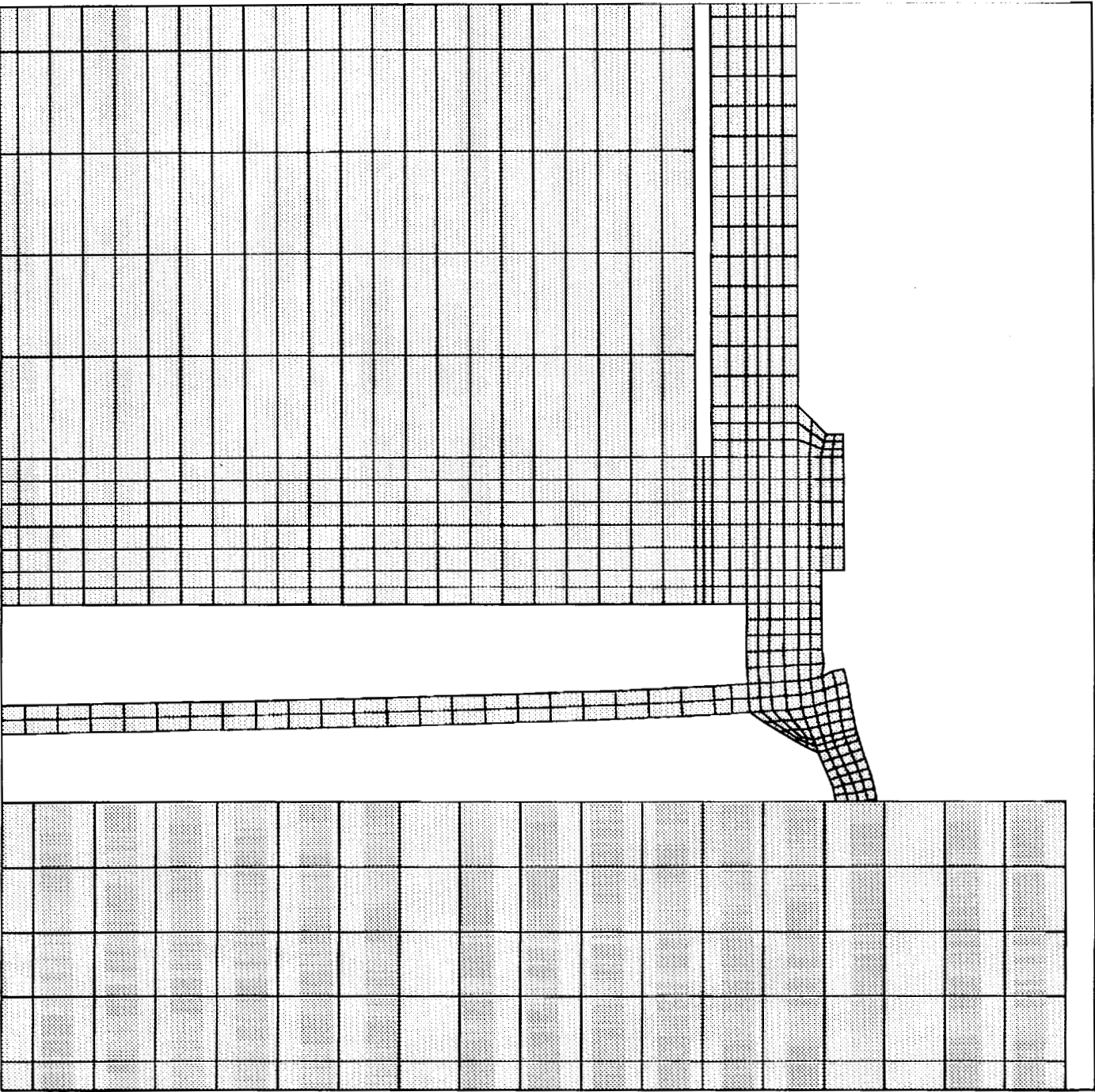

ANSYS 5.4

DISPLACEMENT

TIME=.006444

Figure III-7. Detail of Deformed Configuration of the Naval Waste Package Impacting an Unyielding Surface