Effect of Aging on the PWR Chemical and Volume Control System

Manuscript Completed: September 1994
Date Published: June 1995

Prepared by
E. J. Grove, R. J. Travis

S. K. Aggarwal, NRC Program Manager

Brookhaven National Laboratory
Upton, NY 11973

Prepared for
Division of Engineering Technology
Office of Nuclear Regulatory Research
U.S. Nuclear Regulatory Commission
Washington, DC 20555-0001
NRC Job Code A3270

DISTRIBUTION OF THIS DOCUMENT IS UNLIMITED

Yor

MASTER

DISCLAIMER

This report was prepared as an account of work sponsored by an agency of the United States Government. Neither the United States Government nor any agency thereof, nor any of their employees, make any warranty, express or implied, or assumes any legal liability or responsibility for the accuracy, completeness, or usefulness of any information, apparatus, product, or process disclosed, or represents that its use would not infringe privately owned rights. Reference herein to any specific commercial product, process, or service by trade name, trademark, manufacturer, or otherwise does not necessarily constitute or imply its endorsement, recommendation, or favoring by the United States Government or any agency thereof. The views and opinions of authors expressed herein do not necessarily state or reflect those of the United States Government or any agency thereof.

DISCLAIMER

Portions of this document may be illegible in electronic image products. Images are produced from the best available original document.

ABSTRACT

The effect of aging on the PWR Chemical and Volume Control System (CVCS) has been evaluated. A detailed review of the NPRDS and LER databases for the 1988-1991 time period, together with a review of industry and NRC experience and research, indicate that age-related degradations and failures have occurred. These failures had significant effects on plant operation, including reactivity excursions, and pressurizer level transients. The majority of these component failures resulted in leakage of reactor coolant outside the containment.

A representative plant of each PWR NSSS design (W, CE, and B&W) was visited to obtain specific information on system inspection, surveillance, monitoring, and inspection practices. The results of these visits indicate that adequate system maintenance and inspection is being performed. In some instances, the frequencies of inspection were increased in response to repeated failure events. A parametric study was performed to assess the effect of system aging on Core Damage Frequency (CDF). This study showed that as MOV operating failures increased, the contribution of the High Pressure Injection to CDF also increased.

TABLE OF CONTENTS

	Page
ABSTRACT	iii
SUMMARY	xi
ACKNOWLEDGEMENTS	xiii
1. INTRODUCTION	1-1
1.1 Background	1-1
1.2 Objectives	1-1
1.3 Analysis Methodology and Report Format	1-3
2. DESCRIPTION OF THE CHEMICAL AND VOLUME CONTROL SYSTEM	2-1
2.1 Introduction	2-1
2.2 CVCS Operation and Control	2-1
2.2.1 Typical System Design and Operation	2-1
2.2.2 System Instrumentation	2-5
2.2.3 Modes of Operation	2-7
2.2.3.1 Feed-and-Bleed	2-7
2.2.3.2 Automatic Makeup	2-7
2.2.3.3 Dilution	2-7
2.2.3.4 Boration	2-8
2.2.3.5 Emergency Boration	2-8
2.2.3.6 Manual	2-8
2.3 Design Variations	2-8
2.3.1 Westinghouse	2-8
2.3.2 Combustion Engineering	2-8
2.3.3 Babcock & Wilcox	2-8
3. OPERATING AND ENVIRONMENTAL STRESSES	3-1
3.1 System Operating Stresses	3-1
3.2 Environmental Stresses	3-2
3.3 Effect of Operating and Environmental Stresses on System Components	3-2
4. CVCS OPERATING EXPERIENCE	4-1
4.1 Introduction	4-1
4.2 NPRDS Failures	4-7

TABLE OF CONTENTS (Cont'd)

	Page
4.2.1 Valve Failures	4-7
4.2.2 Pump Failures	4-10
4.2.3 Valve Operator Failures	4-16
4.2.4 Controller Failures	4-16
4.3 CVCS LERs	4-23
4.3.1 Valve Failures	4-23
4.3.2 Pump Failures	4-26
4.3.3 Piping Failures	4-26
4.4 Miscellaneous Failures	4-26
4.5 Summary	4-29
5. EFFECT OF COMPONENT FAILURES ON CVCS SYSTEM	5-1
5.1 Westinghouse, Babcock & Wilcox, and Combustion Engineering CVCS FMEAs	5-1
6. CVCS INSPECTION, SURVEILLANCE, MONITORING AND MAINTENANCE REVIEW (ISM&M)	6-1
6.1 Inspection, Surveillance, and Monitoring Practices	6-1
6.2 Specific Plant Insights	6-1
6.2.1 Westinghouse	6-1
6.2.2 Combustion Engineering	6-3
6.2.3 Babcock & Wilcox	6-6
6.3 Summary	6-8
6.3.1 Pump Packing	6-8
6.3.2 Boric Acid	6-8
6.3.3 Reliability Centered Maintenance	6-9
7. USNRC AND INDUSTRIAL STUDIES	7-1
7.1 USNRC Generic Letters	7-1
7.1.1 Generic Letter 88-05: Boric Acid Corrosion of Carbon Steel Reactor Pressure Boundary Components in PWR Plants	7-1
7.2 NRC Bulletins	7-1

TABLE OF CONTENTS (Cont'd)

	Page
7.2.1 Pipe Cracks in Chemical Volume Control Due to Excessive Charging Pump Vibrations	7-1
7.2.2 NRC Bulletin No. 80-05 Vacuum Condition Resulting in Damage to Chemical Volume Control System Holdup Tanks	7-2
7.2.3 NRC Bulletin No. 88-04: Potential Safety-Related Pump Loss	7-2
7.3 Industrial Research	7-2
7.3.1 EPRI TR-100359 Volume 1 Nuclear Power Plant Resource Book	7-2
7.3.2 EPRI NP-5796 Valve Performance in PWR Chemical and Volume Control Systems	7-3
7.4 Other Miscellaneous Reports Documenting CVCS Operating Events	7-3
7.4.1 Metallurgical Investigation of Cracking in the Boric Acid Piping at Prairie Island 1	7-3
7.4.2 350 Gallon Leak from Chemical and Volume Control System	7-7
7.4.3 CVCS Letdown Line Water Hammer Event	7-7
7.5 Summary	7-7
8. EFFECT OF CVCS AGING ON CORE DAMAGE FREQUENCY	8-1
8.1 Discussion of Results	8-1
8.2 Summary	8-7
9. CONCLUSIONS AND RECOMMENDATIONS	9-1
9.1 Conclusions	9-1
9.2 Recommendations	9-2
10. REFERENCES	10-1
APPENDIX A Westinghouse Chemical and Volume Control System Principal Component Data Summary	A-1
APPENDIX B Combustion Engineering Chemical and Volume Control System Principal Component Data Summary	B-1
APPENDIX C Babcock & Wilcox Makeup and Purification System Principal Component Data Summary	C-1
APPENDIX D Core Damage Frequency for Sequences with HIP Failures Composite Tree	D-1

LIST OF FIGURES

		Page
1.1	Chemical and volume control system	1-4
2.1	Typical CVCS design	2-2
2.2	Westinghouse CVCS with boron thermal regeneration system	2-10
2.3	Combustion engineering CVCS typical system configuration	2-11
2.4	Babcock & Wilcox makeup and purification system typical configuration	2-12
4.1	CVCS failure occurrences	4-2
4.2	CVCS component failures reported to NPRDS	4-2
4.3	CVCS component failures reported to SCSS	4-3
4.4	System functions affected by component failure	4-4
4.5	Effect of failure (NPRDS)	4-5
4.6	Effect of failure (SCSS)	4-5
4.7	CVCS failures attributable to aging (NPRDS)	4-6
4.8	CVCS failures attributable to aging (SCSS)	4-6
4.9	Valve failures vs. valve type (NPRDS)	4-8
4.10	Valve failures vs. valve operator (NPRDS)	4-8
4.11	Valve age at failure (NPRDS)	4-9
4.12	Valve failures vs. sub-component failed (NPRDS)	4-9
4.13	Valve failure modes (NPRDS)	4-10
4.14	Valve failure causes (NPRDS)	4-11
4.15	Valve failures vs. corrective action (NPRDS)	4-11
4.16	Pump type vs. failure occurrence (NPRDS)	4-13
4.17	Pump inlet size vs. failure occurrence (NPRDS)	4-13
4.18	Pump age at failure (NPRDS)	4-14
4.19	Pump failure vs. sub-component failed (NPRDS)	4-14
4.20	Pump failure mode (NPRDS)	4-15
4.21	Pump failure cause (NPRDS)	4-15
4.22	Pump failures vs. corrective action (NPRDS)	4-17
4.23	Valve operator failures vs. operator type (NPRDS)	4-17
4.24	Valve operator age at failure (NPRDS)	4-18
4.25	Valve operator failure mode (NPRDS)	4-18
4.26	Valve operator corrective action (NPRDS)	4-19
4.27	Valve operator failure vs. failed sub-component (NPRDS)	4-19
4.28	Valve operator failure cause (NPRDS)	4-20
4.29	CVCS controller failures vs. inputs measured (NPRDS)	4-21
4.30	Controller failure modes (NPRDS)	4-21
4.31	Controller age at failure (NPRDS)	4-22
4.32	Controller failure causes (NPRDS)	4-22
4.33	Valve failures vs. valve type (SCSS)	4-24
4.34	Valve failures vs. failure cause (SCSS)	4-25
4.35	Valve failures vs. failure effect (SCSS)	4-25

LIST OF FIGURES (Cont'd)

	Page
4.36 Pump failure vs. pump function (SCSS)	4-27
4.37 Pump failures vs. failure cause (SCSS)	4-27
4.38 Pump failure vs. failure effect (SCSS)	4-28
4.39 Piping failure causes (SCSS)	4-28
4.40 Piping failures vs. failure effect	4-29
6.1 Boric acid transfer pump modifications	6-4
7.1 Wear parts in a typical charging flow control valve	7-5
7.2 Flow diagram CVCS and boron thermal regeneration interface	7-8
8.1 HPI portion of CVCS	8-6

LIST OF TABLES

		Page
1.1	Years of Operation - PWR Plants	1-2
2.1	CVCS Functions	2-3
2.2	Typical CVCS Design Parameters	2-4
2.3	PWR Plants with Separate High Pressure Injection Pumps	2-6
2.4	Westinghouse Plants with Boron Thermal Regeneration Capability	2-9
3.1	CVCS Component Potential Degradation Mechanisms, Failure Modes, and Detection Methods	3-3
5.1	Westinghouse CVCS FMEA (Letdown, Boron Storage, RCP Seal Cooling and Charging)	5-3
5.2	Babcock & Wilcox - Makeup and Purification System FMEA (Letdown, Boron Storage, RCP Seal Cooling and Charging)	5-19
5.3	Combustion Engineering CVCS FMEA	5-33
6.1	Inspection, Surveillance and Monitoring Practices for the CVCS System	6-2
6.2	CVCS Problem Summary - CE Plant	6-5
6.3	Summary of Pump Packing Type and Failure Rates	6-7
7.1	Charging Flow Control Valve Wear Materials in Certain Westinghouse Plants	7-4
7.2	Estimated Cobalt Input from Corrosion and Wear of High Cobalt Alloys in CVCS Valves	7-6
8.1	HPI Composite Tree Cutset Report	8-2
8.2	A Listing of the Major HPI Failure Modes	8-5
8.3	Results of the Parametric Study	8-7

SUMMARY

The Pressurized Water Reactor (PWR) Chemical and Volume Control System (CVCS) is designed to provide both safety and non-safety related functions. During normal plant operation it is used to control reactor coolant chemistry, and letdown and charging flow. In many plants, the charging pumps also provide high pressure injection, emergency boration, and RCP seal injection in emergency situations. This study examines the design, materials, maintenance, operation and actual degradation experiences of the system and main sub-components to assess the potential for age degradation. Since the CVCS provides many normal and emergency operating functions, it is important to understand the effect of aging in order to detect and correct these instances prior to component failure.

The actual design of, and number of components in the system, varies between plant designs, as well as plant-to-plant. Sufficient redundancy is provided for the major sub-components (valves, deionizers, and pumps) such that failures do not result in an inoperable system. However, these component failures do represent a loss of redundancy, which may affect plant operation and safety if other redundant components also fail.

A detailed review of the Nuclear Plant Reliability Data System (NPRDS) and the Licensee Event Report (LER) database, together with a review of industry and NRC experience and research, highlighted the fact that age-related degradations and failures have occurred. These failures had significant effects on the plant, including reactivity excursions, and pressurizer level transients. These occurrences resulted in components being removed from service for repair, power reductions due to reactor coolant leakage, and unnecessary system stresses in response to these events.

The majority of the system failure occurrences were due to degradation and failure of system valves, positive displacement pumps, and valve operators. Aging accounted for over 50% of these occurrences.

The following main failures were highlighted by this review of operational experience:

1. Reactor coolant leakage was primarily due to charging pump packing failures commonly associated with positive displacement pumps and vibration-induced damage to the piping located both inside and outside of containment. These failures resulted in leakage of reactor coolant. Unidentified leakages inside containment in excess of the technical specification limit of 1 gpm resulted in power decreases and unit shutdowns. Leakages outside of containment resulted in ALARA and maintenance concerns. In response to the packing failures, some plants increased the frequency of inspections, or considered the feasibility of replacing the pumps with centrifugal-type pumps.
2. Gate and globe type of valves were most frequently reported failed. Such valves are used for isolation and flow control throughout the system. Packing failures accounted for the majority of these occurrences. External leakage commonly resulted from these events.
3. Failures of valve operators primarily pneumatic and motor-operated, also were frequently reported. These events resulted in the valve failing to operate properly. In pneumatic valves, failure of the diaphragm accounted for over 15% of the occurrences.

4. Storage of the highly concentrated boric acid solution caused numerous operational failures (e.g., corrosion, precipitation). Failures of the boric acid tank heaters and pipe heat tracing resulted in the precipitation of boric acid, resulting in flow obstructions. Leakages of this highly concentrated solution corroded carbon steel fasteners and components. Erroneous level indications resulted from the formation of boric acid crystals on the instrumentation.

For the major system components, the operating and environmental stresses on the system were evaluated including the potential aging effects from continued exposure to these stresses. Detailed Failure Modes and Effects Analysis (FMEA) were performed for each NSSS design. Methods of detecting failures were also examined, including functional indicators and system operating characteristics.

Plant visits were made to one representative plant of each NSSS design to obtain plant specific information on system inspection, surveillance, monitoring, and maintenance practices. The majority of system inspections are performed in accordance with ASME Section XI, Appendix J, and Technical Specification requirements. Each of the three plants visited used Reliability Centered Maintenance (RCM) techniques to insure that adequate maintenance and surveillance was being performed on the components. These techniques proved valuable in identifying some components which were being replaced unnecessarily. In addition to being costly, these practices also induce unnecessary stresses on the components.

A review of industry and NRC experience with CVCS operation confirmed the conclusions of this Phase I study. Studies performed by EPRI concluded that the system valves were subject to age related wear, and compared to valves in other systems, contributed the most cobalt into a plant. The studies also highlighted the susceptibility of the system components to normal and abnormal operating stresses, including those resulting from required testing and inspections (e.g., running pumps in the minimum flow condition).

As part of this analysis, a parametric study was also performed to assess the effect of system aging on Core Damage Frequency (CDF). Since the majority of CVCS functions are not safety-related, the impact of failures are not assessed in plant PRAs. However, the High Pressure Injection System (of which the CVCS charging pumps are part of) was found to be of medium importance, accounting for 10% of the CDF. Human errors were the primary contributor to this percentage, followed by motor-operated valve (MOV) failures. Aging of the system, particularly MOVs, was found to have a potentially significant impact upon system operability. If the unavailability estimate for MOV operating failures were increased by a factor of 10, the HPI CDF contribution would be increased by a factor of 5. This highlighted the importance of monitoring and detecting age degradation prior to component failure.

The results of this NPAR study show that aging degradation and failures has occurred in the CVCS. These failures have not prevented the system from responding as designed in an emergency, but have resulted in normal plant operation perturbations. These occurrences have resulted in unnecessary actuation and operation of other system components in response, causing unnecessary stresses. The results of the plant visits indicate that significant attention is being concentrated on the CVCS, and that maintenance practices are being employed in response to specific component failure histories. However, the large number of failure events reported to the databases, indicating that system failures are still occurring, highlights the need for continued attention to the operation and aging of the system.

ACKNOWLEDGEMENTS

The Authors wish to acknowledge the technical direction of the NRC Program Manager, Mr. Satish K. Aggarwal.

We would like to express our gratitude to various members of the Engineering Technology Division of BNL, including Mr. Robert Hall, Mr. John Taylor, Mr. James Higgins, Mr. Robert Lofaro, Mrs. Adele DiBiasio, Mr. Joseph Carbonaro, Mr. James Davis, and Mr. Michael Villaran for providing technical assistance guidance, and for reviewing this report. We also appreciate the efforts of the utilities that provided the operating data, and the NPAR laboratories and NEI for reviewing and commenting on this report.

Finally, we wish to thank Mrs. Patricia Van Gorp for her patience and excellent preparation of this manuscript. We also acknowledge the Engineering and Technology Information Center at BNL for their assistance in obtaining the support documentation for this report.

1. INTRODUCTION

The Chemical and Volume Control System (CVCS)* is essential to the safe and reliable operation of Pressurized Water Reactors (PWRs). Among its many functions, the CVCS provides for the control of reactor coolant chemistry, and letdown and charging flow during normal operation, and in many plants, high pressure injection during transients and accidents.

Failure or degradation of this system's components, due to aging, may significantly affect plant operations (reactivity and pressurizer level control). Failures which affect the system's non-safety related functions do not usually result in an increase in plant risk. However, many plants utilize the same charging pumps for charging flow and high pressure injection. Failure to provide this emergency flow, when required, would represent a significant increase in plant risk.

An aging assessment was performed on the PWR CVCS system and its main sub-components. The results of this Phase I assessment are described in the following sections of this NUREG. This program was performed under the United States Nuclear Regulatory Commission's (NRC) Nuclear Plant Aging Research (NPAR) Program.

1.1 Background

Though the CVCS system at each PWR performs basically the same functions, plant to plant, and vendor design differences do exist. Some plants use regenerative heat exchangers to cool both the letdown flow and heat the charging flow. The number and type of deionizers (anion, cation, mixed-bed) used to purify the

coolant also varies. Charging flow is provided by either positive displacement or centrifugal pumps, or a combination of each. In addition, the newer Westinghouse plants have a boron thermal regeneration system which permits load following. However, since this is not a normal mode of plant operation, the sub-system has not been used widely, though component failures in this part of the system have occurred.

Table 1.1 provides a listing of each PWR plant and age. As shown, the majority of currently operating PWR plants (65%) have been in service for greater than 10 years. To maintain the operability of the system and components, it is essential to understand the cumulative effect of the induced stresses, and detect aging prior to failure. Failures of the CVCS system have resulted in significant system and plant perturbations (e.g., reactivity transients, pressurizer level fluctuations).

1.2 Objectives

As reactor years of operation increased, a need developed to assess the effects of plant aging on safety. The Director of the Office of Nuclear Reactor Regulation of the U.S. Nuclear Regulatory Commission (NRC) identified this need, and the Nuclear Plant Aging Research (NPAR) Program was developed by the Office Of Nuclear Regulatory Research to assess this. The technical and safety issues of the Program, components and systems to be evaluated, and potential uses of the results, are described in NUREG-1144.¹

The objectives of a Phase I system study are described in NUREG-1144 and the BNL Aging and Life Extension Assessment Program (ALEAP) Systems Level Plan.² Specifically, these objectives are to perform the following:

*For brevity, the general term Chemical and Volume Control System (CVCS) will be used in the report to refer to Westinghouse (W), Combustion Engineering (CE) and Babcock & Wilcox (B&W) plants. In B&W plants, the system is identified as the makeup and Purification System. When specifically applicable to B&W plants, the term Makeup and Purification System will be used.

Table 1.1 Years of Operation - PWR Plants

Years of Operation	Westinghouse Plants	Combustion Engineering	Babcock & Wilcox
5-10	<u>21 units</u> Shearon Harris Beaver Valley 2 Byron 1,2 Braidwood 1,2 Catawba 1,2 Vogtle 1 Millstone 3 Diablo Canyon 1,2 Callaway Wolf Creek McGuire 2 Braidwood 1,2 South Texas 1,2 Seabrook Vogtle 2	<u>5 units</u> Palo Verde 1,2,3 San Onofre 3 Waterford 3	
11-15	<u>7 units</u> Farley 2 Summer 1 North Anna 2 McGuire 1 Salem 2 Sequoyah 1,2	<u>3 units</u> San Onofre 2 St. Lucie 2 Arkansas 2	
16-20	<u>12 units</u> Prairie Island 2 Kewaunee Farley 1 Beaver Valley 1 North Anna 1 D.C. Cook 1,2 Indian Point 2,3 Trojan Salem 1 Zion 2	<u>4 units</u> St. Lucie 1 Calvert Cliffs 1,2 Millstone 2	<u>6 units</u> Crystal River Davis Besse Arkansas 1 Oconee 2,3 Three Mile Island 1
Greater than 20	<u>11 units</u> Prarie Island 1 Ginne Pt. Beach 1,2 Robinson 2 Turkey Point 3,4 Surry 1,2 Zion 1 Haddam Neck	<u>3 units</u> Fort Calhoun Maine Yankee Palisades	<u>1 unit</u> Oconee 1

- a detailed evaluation of operating experience data,
- an analysis of industry operating and maintenance data,
- an identification of failure modes, causes, and effects, and
- a review of design operating environment, and performance requirements. To meet these objectives, the following tasks were completed for each PWR NSSS design:
 - A. The operating experience was reviewed to identify the dominant component failure modes, effects, and mechanisms,
 - B. A Failure Modes and Effects Analysis (FMEA) for each main sub-system was completed to identify the components which affect the functions of the system,
 - C. One plant of each NSSS design was visited to obtain current maintenance, inspection, and surveillance practices.

1.3 Analysis Methodology and Report Format

In a Pressurized Water Reactor (PWR), both the control rod assemblies (CRAs) and the Chemical and Volume Control System (CVCS) are necessary to control reactivity. The CVCS compensates for long-term reactivity effects due to coolant temperature changes, xenon concentrations, and fuel burnup by controlling the amount of soluble boron in the reactor coolant. The control rod drive mechanisms (CRDMs) position the movable CRAs within the core to control short term reactivity effects.

Several CVCS components are also used in the high pressure injection system. The effect of aging on the HPI was previously analyzed by the Idaho Nuclear Engineering Laboratory (INEL).³ Efforts were made during this Phase I study not to duplicate the HPI aging assessment. However, some duplication was unavoidable since the failures for the components used by each system affected both. For example,

charging pump failures would have affected both the ability to provide charging and HPI flow. The effect of aging on PWR control rod drive assemblies was also previously analyzed by BNL.^{4,5}

A simplified CVCS system schematic is shown in Figure 1.1. The primary sub-systems included in this study are:

- letdown cooling system,
- demineralizers,
- boron thermal regeneration system,
- volume control storage tank,
- boric acid supply,
- charging pumps, and
- RCP seal water injection

Most of the CVCS components are located outside of containment, so aging degradations may result in external leakage of the reactor coolant.

To fully understand the effect of system aging, specific information on the system's operating characteristics, material, and design function is presented in Section 2 for each NSSS design. This information was obtained from a review of the utilities' Final Safety Analysis Reports, technical reports, and system descriptions. Appendices A, B, and C contain design and operating data for the individual components.

Section 3 evaluates the operational and environmental impacts of the stresses on both the system and components. The effect of required surveillance and testing is considered, along with other stresses including mechanical wear, vibration, and corrosion.

Operating experience for each NSSS design, for 1988-1991, is presented in Section 4. The information used to evaluate the operating experience was obtained from a variety of sources, including:

- Nuclear Plant Reliability Data System (NPRDS)
- Licensee Event Reports (LERs)

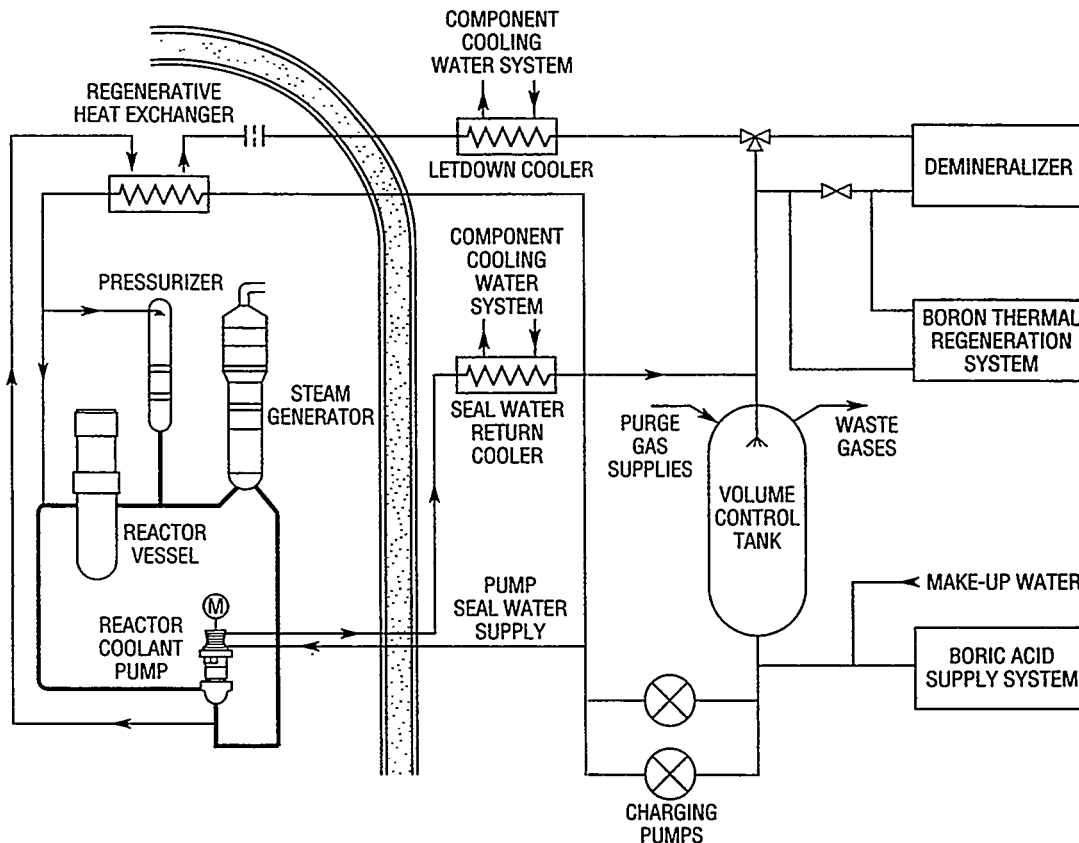

Figure 1.1 Chemical and volume control system⁶

- Plant Specific Failure Data
- Operating Plant Visits and Discussions With Plant Personnel

This section discusses the primary failure causes and effects for the main system components. The databases were also reviewed to identify the particular sub-component(s) which resulted in pump and valve failure. The percentages of failures directly attributable to aging degradation is presented. The effect of the failure on the system is also presented.

The results of the detailed design, operating stressors, previous system studies, and operating experience reviews are combined into a failure mode and effects analysis for the primary components of the CVCS system (Section 5). Each individual FMEA analyzes the primary component failures which may result in system or plant effects. Detection methods for each failure are also presented. These methods

include functional indicators and the system's or plant's operating characteristics which would alert the plant operator to aging degradation.

Section 6 discusses the results of visits to representative plants of each NSSS design. Information on system operating experience, inspection, surveillance, and maintenance practices is presented. The advantages of performing a reliability centered maintenance analysis on the CVCS to identify the critical components and failure modes is also presented.

The CVCS system has been the subject of several industry and EPRI studies. In addition, degradation of the system has resulted in the issuance of NRC Bulletins and Information Notices alerting utilities of these failures. These have been in response to significant system and operating failures. Section 7 summarizes this work.

The effect of system aging on core damage frequency is assessed in Section 8. A base case system unavailability estimate based upon fault tree analysis is provided. The results of a parametric study, in which component failure rates are varied to simulate the potential effect of aging are also presented. Major contributors to

system unavailability, including specific component failures and human errors are also evaluated.

Section 9 presents the results and conclusions of this Phase I aging assessment.

2. DESCRIPTION OF THE CHEMICAL AND VOLUME CONTROL SYSTEM

2.1 Introduction

The Chemical and Volume Control System (CVCS) for PWR plants (W, CE, and B&W), provides both normal and emergency operation functions (Table 2.1). During normal operation, the three primary system functions are to purify the reactor coolant, control RCS inventory (pressurizer level control), and provide RCP seal water injection. During an emergency, the primary safety functions for the majority of PWR plants are to provide high pressure safety injection, RCP seal injection, and emergency boration. In addition, the containment isolation system, which includes CVCS valves, isolates the letdown and charging lines. With the exception of the CE and several Westinghouse plants, the majority of PWR plants also use the charging pumps for high pressure injection.

The majority of the system's components, with the exception of those required for high pressure injection, emergency boration, reactor coolant pump seal injection, and containment isolation, are not necessary to mitigate the effects of an accident, and thus are not safety-related. Upon an Engineered Safety System (ESF) actuation, the system's isolation valves close, and the charging pumps are realigned with the refueling water storage tank (RWST) to provide coolant to the Reactor Coolant System (RCS).

During normal plant operation, letdown flow is typically set between 45 and 90 gpm, and pressurizer level is stabilized by controlling the charging flow rate. As the RCS temperature or reactor power change, the pressurizer level increases or decreases, and the CVCS responds to these changes to restore the pressurizer level.

The typical system design used in the majority of plants is shown schematically in Figure 2.1. Specific variations exist between the

individual NSSS designs, as well as from plant to plant. System operation and instrumentation is discussed in Section 2.2, while Section 2.3 highlights the major system design variations.

2.2 CVCS Operation and Control

2.2.1 Typical System Design and Operation⁷⁻¹³

With the exception of times when the boron concentration must be adjusted (increased or diluted), the CVCS automatically maintains and purifies the RCS (feed-and-bleed). Table 2.2 provides the typical design and operating parameters of the system for each PWR design. Specific data for the major system components in the Westinghouse, Combustion Engineering, and Babcock & Wilcox plants is included in Appendices 1, 2, and 3, respectively.

Reactor letdown entering the CVCS is controlled by redundant, isolation valves. These valves are interlocked with the pressurizer, and close on a low pressurizer level alarm to isolate the letdown portion of the system. A combination of two heat exchangers are used to reduce the coolant temperature from reactor temperature (540°F) to approximately 120°F. The Westinghouse and Combustion Engineering CVCS designs use a regenerative heat exchanger to initially lower the letdown flow temperature from reactor coolant temperature of 540°F to approximately 290°F, while increasing the charging flow temperature before returning it to the RCS. A second letdown heat exchanger which is non-regenerative, lowers the letdown fluid temperature to approximately 120°F. This reduction ensures the proper operation of the ion exchanger. Cooling water to the second letdown heat exchanger is provided by the Component Cooling Water (CCW) system. The effect of aging on the CCW system was studied in NUREG/CR-5052 and 5693.^{31,32} A pressure-regulating valve controls fluid pressure to ensure it does not flash to steam during the temperature reduction.

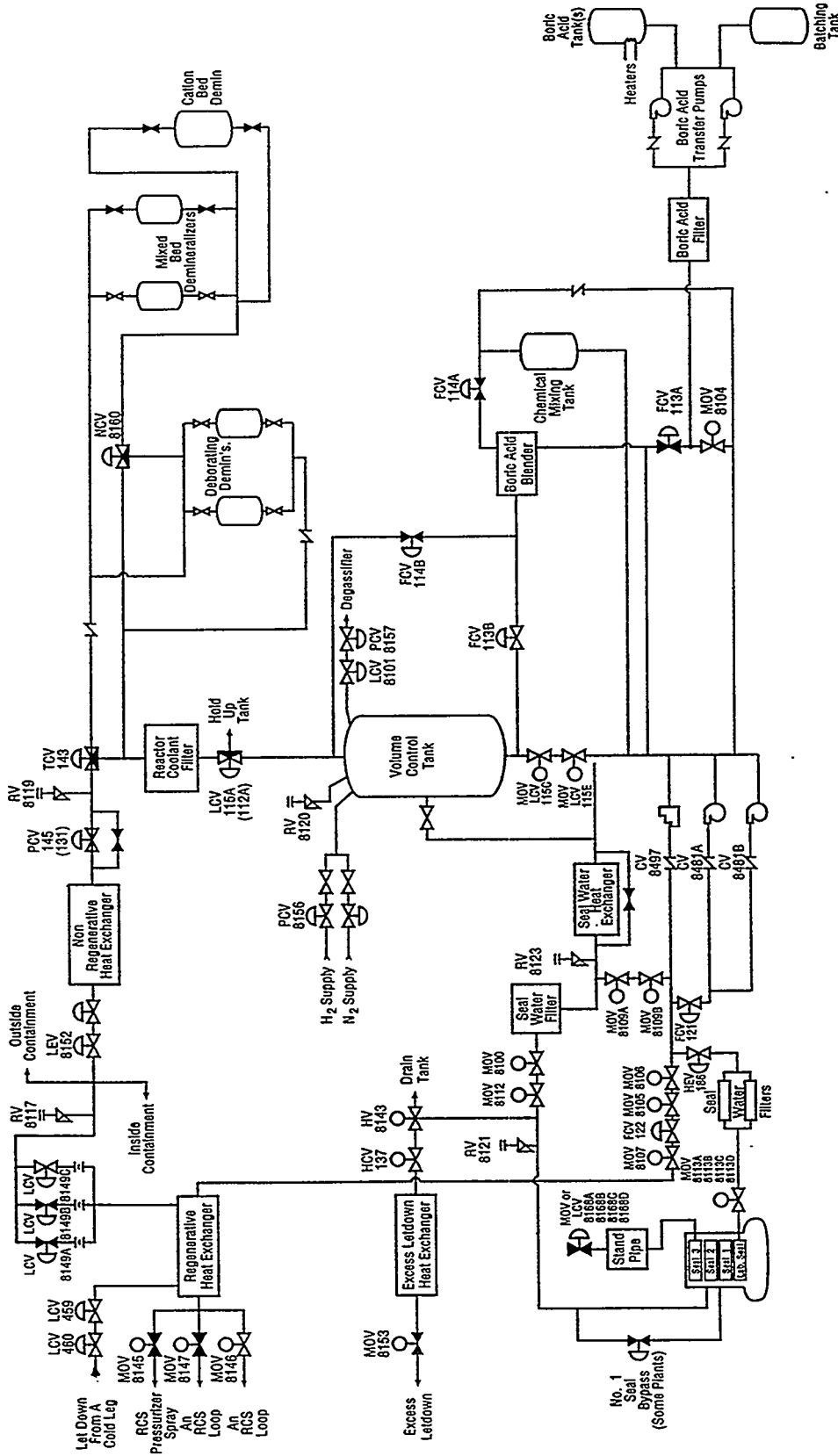

Figure 2.1 Typical CVCS design

Table 2.1 CVCS Functions

Function	Normal/Emergency
Reactor Coolant Purification	N
Reactor Coolant Boron Control	N
Pressurizer Level Control	N
Process Reactor Coolant Effluent	N
Chemical Treatment of Reactor Coolant	N
Reactor Coolant Pump Seal Water Flow	N
Collect Reactor Coolant Pump Bleedoff (B&W)	N
High Pressure Injection (CE and W)	E
RCS Emergency Boration	E
Containment Isolation	E
Pressurizer Auxiliary Spray	N

Letdown orifice valves downstream of the regenerative heat exchanger control the letdown flow rate. This control is required to regulate the amount of RCS purification, or to achieve a faster change in RCS boron concentration. The letdown orifice valves also isolate the letdown line upon an ESF signal.

A three-way temperature divert valve directs the letdown flow, depending upon fluid temperature. Normally, the flow is directed to the ion exchangers. However, if the temperature exceeds approximately 140°F, the fluid is bypassed around the ion exchangers. High temperatures reduce the efficiency of the ion exchanger, and shorten the lifetime of the resin bed.

A combination of mixed bed and cation ion exchangers purify the coolant. Redundant ion exchangers are installed to permit one to be

removed for maintenance, while still maintaining the system operational. Mixed-bed ion exchangers contain both anions and cations, and also serve as very effective crud filters. B&W provides two, parallel mixed-bed ion exchangers and a cation exchanger which is used to control lithium, cesium, yttrium, or molybdenum. Letdown filters, located downstream of the ion exchangers, provide mechanical filtration, and prevent broken resin beads from entering the RCS.

A level divert valve controls the direction of flow from the filters. Normally, flow is directed to a spray nozzle in the top of the volume control tank or makeup tank in B&W plants. However, flow can be diverted to other storage tanks. This is necessary to maintain sufficient volume in the tank to accommodate pressurizer level changes. By controlling both letdown and charging flow, pressurizer level can be adjusted.

Table 2.2 Typical CVCS Design Parameters

Parameter	Westinghouse			Combustion Engineering	Babcock and Wilcox
	2 Loop	3 Loop	4 Loop		
Seal water injection flow rate, for the reactor coolant pumps, nominal, gpm. ¹	16	24	32	-	32-60
Seal water return flow rate, for the reactor coolant pumps, nominal, gpm. ¹	6	9	12	6	6
Letdown flow Normal, gpm Maximum, gpm	40 80	60 120	75 120	38 126	50 200
Charging flow (excludes seal water) Normal, gpm Maximum, gpm	30	45 105	55 100	44 132	small ² small
Temperature of letdown reactor coolant entering system, °F	< 545	542-555	< 560	550	< 510
Temperature of charging flow directed to reactor coolant system, °F	488	497-501	518	410	-
Temperature of effluent directed to boron recycle system, °F	127	115	115-127	120	120
Maximum pressurization required for hydrostatic testing of reactor coolant system, psig	3107	3107	3107	3025	3200

Note:

- Parameters for RCP are representative, plant to plant variations exist. For detailed information, see NUREG/CR-4948.³⁰
- The majority of the makeup flow is provided via the RCP seals.

An overpressure of hydrogen cover gas is maintained in the Volume Control Tank (VCT) which enables the hydrogen gas to be absorbed by the fluid as it enters the tank. Upon reaching the core, the radiation will cause the hydrogen to associate with any free oxygen. Chemical addition taps are also provided for adding lithium hydroxide and hydrazine. Lithium hydroxide assists in controlling pH to minimize corrosion, and hydrazine serves as an oxygen scavenger during cold shutdowns. An additional tap in the line between the volume-control tank and the charging pump suction allows for emergency boration. To resist corrosion, the tank is fabricated from austenitic stainless steel. Redundant, normally closed motor-operated valves (MOVs) are located between the Refueling Water Storage Tank (RWST) and the charging pumps.

Depending upon the plant's design, the charging pumps may serve both as the normal source of charging flow to the RCS, and as high-pressure injection pumps in an emergency. The majority of PWR plants use the charging pumps to supply high pressure injection. However, CE and some Westinghouse plants have separate high pressure injection pumps (Table 2.3) which are not used to supply charging flow during normal plant operation.

Typically, three pumps are provided (combination of centrifugal and positive displacement) for charging and high pressure injection. The centrifugal pumps are normally used for emergency high pressure injection, and power is supplied from a vital, Class 1E bus. For plants where the charging pumps do not provide emergency cooling, then power may be supplied from non-vital power busses. Most of the charging pump discharge flow enters the charging header, with some diverted for reactor cooling pump seal cooling. The charging flow is directed through a regenerative heat exchanger in order to increase the temperature before injection back to the RCS; this minimizes the risk of thermal shock to the reactor coolant loop nozzle penetrations.

The reactor makeup portion of the system is used to adjust the RCS boron concentration (increase or decrease) and compensate for any system leakage while maintaining a constant boron concentration. Water (from the primary water storage tank) is fed through the blender by a flow control valve to the volume control tank to dilute the RCS boron concentration. To increase it, concentrated boric acid is transferred from the boric acid tanks by dedicated transfer pumps, through the blender, to the charging pump suction. The boric acid tanks are electrically heated and the piping in the boric acid flow path is heat traced to ensure that the boric acid remains in solution. The boric acid blender limits the flow to approximately 10 gpm, so an alternate boration flow path is provided for emergencies. Both boric acid and pure water are used to compensate for RCS leakage and maintain the system boric acid concentration.

2.2.2 System Instrumentation

Process control instrumentation is installed to monitor key operational parameters. The instrumentation furnishes input signals for monitoring, alarming, and/or control purposes. Indications and alarms are normally provided for:

- a. Temperature
 1. Seal water return temperature upstream and downstream of the heat exchanger,
 2. RCP No. 1 seal outlet temperatures to monitor seal water leakoff temperature
 3. Temperatures upstream and downstream of the regenerative heat exchangers to ensure that the fluid does not exceed the saturation temperature of the letdown stream at the pressure prevailing downstream of the letdown orifices,
 4. Discharge temperature of letdown line relief valves, for actuation or leak indication,
 5. VCT outlet temperature,

Table 2.3 PWR Plants with Separate High Pressure Injection Pumps

Westinghouse	
Ginna	H.B. Robinson
Kewaunee	Turkey Point 3 & 4
Point Beach 1 & 2	Indian Point 2 & 3
Prairie Island 1 & 2	Yankee Rowe
Babcock & Wilcox	
Davis Besse	
Combustion Engineering	
Arkansas 2	San Onofre 2 & 3
Calvert Cliffs 1 & 2	St. Lucie 2 & 3
Fort Calhoun	Waterford 3
Millstone 2	Palo Verde 1,2,&3
Palisades	

6. Outlet temperature of the letdown heat exchanger to ensure it does not exceed limits necessary for proper demineralizer operation,
7. Lower bearing temperatures on the RCPs to ensure adequate cooling. High temperatures could be an indication of seal water loss or reactor coolant backflow,
8. Temperature of the boric acid batching tank and flowpath to ensure an adequate boric acid solution,

b. Pressure

1. Seal water pressure upstream and downstream of the seal water filter to ensure proper operation,
2. Letdown heat exchanger outlet pressure used to set a control valve to match back pressure on RCP seals,

3. RCP seals differential pressure which indirectly monitors the direction and magnitude of seal water injection.
4. Pressure downstream of the letdown heat exchanger to prevent steam flashing,
5. Pressure of the demineralizers upstream and downstream,
6. VCT pressure to ensure overpressurization,
7. Charging and boric acid pumps suction and discharge pressure,
8. Differential pressure across seal injection and boric acid filters.

c. Flow

1. RCP seal water injection flow to ensure adequate flow,
2. Letdown flow rate,
3. Flow rate of the demineralizer and deionizer,

4. Controlled leakage flow of the RCP seal water,
5. Bypass flow to RCP No. 1 seal of the monitor seal water flow,
6. Charging flow,
7. Emergency boration flow.
8. Makeup and blender flow.

d. Water Level

1. VCT level
2. Reactor coolant stand pipe level to monitor seal backpressure
3. Boric acid tank level

Some specific control functions include:

- a. Letdown flow is diverted to the VCT upon high temperature indication,
- b. Pressure is controlled upstream of the letdown heat exchanger to prevent flashing to steam of the letdown flow,
- c. Charging flow rate is controlled during charging pump operation to ensure acceptable power operation,
- d. Water level is controlled in the VCT,
- e. RCP seal injection flow is controlled,
- f. Temperature of borated water is controlled to maintain the boric acid in solution.

2.2.3 Modes of Operation

Reactivity control in PWRs is controlled by a combination of control rods and the CVCS. The control rods are positioned in the core to control short-term reactivity effects. The CVCS compensates for long-term reactivity effects due to coolant temperature changes, xenon concentration, and fuel burn-up by controlling the amount of soluble boron in the RCS.

The CVCS can be placed in several different modes of operation, depending primarily upon plant operating status. These are feed-and-bleed, automatic makeup, dilution, boration, emergency boration and manual.

2.2.3.1 Feed-and-bleed

The charging and the letdown functions of the CVCS maintain a programmed pressurizer water level, which, in turn, maintains a proper coolant inventory during all phases of plant operation. This is achieved by a continuous feed-and-bleed process, during which the feed rate is automatically controlled based upon pressurizer level or through control valves. The actual bleed rate is chosen to suit various operational requirements by selecting the proper combination of letdown orifices.

During this mode of operation, the CVCS cools and maintains the proper water-chemistry levels, as described in Section 2.2.1.

2.2.3.2 Automatic makeup

Under this mode of operation, the CVCS automatically provides a boric acid solution preset to match the RCS boron concentration. This compensates for minor coolant leakages without significantly changing the boron concentration. Upon receipt of a pre-set low level signal from the VCT level controller, a signal is sent to open the makeup stop valve to the charging pumps suction, the concentrated boric acid control valve, and the primary water makeup control valve. The flow controllers then blend the makeup stream to the desired concentration of boric acid. Makeup addition to the suction header of the charging pumps causes the VCT level to rise. Upon attaining the pre-set level, makeup addition is halted.

2.2.3.3 Dilution

Under this mode of operation, a pre-selected amount of primary water makeup, at a set flow rate, is added to the RCS. This allows primary water to be added to the VCT and to the charging pump header. When the preset amount of water has been added, the batch integrator closes the primary water makeup control valve and stops the reactor water makeup pump.

2.2.3.4 Boration

This mode of operation is the reverse of the dilution mode, and adds a pre-selected concentration of boric acid solution to the RCS. The makeup stop valves to the VCT are closed, and the makeup stop valve from the boric acid tank to the suction header of the charging pumps is opened. Typically, the total quantity of boric acid solution added is so small that it has only a minor effect on VCT level. When the desired concentration increase has been attained, the batch integrator causes the boric acid transfer pumps to stop, and closes the boric acid control valve.

2.2.3.5 Emergency Boration

The CVCS Emergency Boration system is manually initiated to provide negative reactivity insertion for shutdown related events such as reactor trips with rod(s) stuck out of the core, or inadequate boron concentration during shutdowns or refuelings. This portion of the system consists of the boric acid tanks, transfer pumps, flow control valves, and charging pumps. The concentrated boric acid is discharged to the RCS via the normal charging line. A redundant flow path, required by Technical Specifications, is the High Pressure Safety Injection System. This system consists of the RWST, flow control valves, and the charging pumps.

2.2.3.6 Manual

The manual mode of operation allows a pre-selected quantity and blend of boric acid solution to be added to the refueling water storage tank, spent fuel pool, or other locations where needed via temporary connections. While in this mode of operation, the automatic RCS makeup function cannot operate. The discharge flow path is obtained by opening the desired manual valves.

2.3 Design Variations

2.3.1 Westinghouse^{14,15}

The one major design change made to the Westinghouse CVCS has been to allow load following capability over the entire fuel cycle. Older plants only had the capability to load follow over certain portions of the fuel cycle. The addition of the Boron Thermal Regeneration System (Figure 2.2) provides plants the capability to load follow at any point in the fuel cycle (Table 2.4). Such capability increases the complexity of the system's design, though plants do not generally use this function. Storage and release of boron is determined by the temperature of the letdown stream at the inlet to the thermal regeneration demineralizers. A chiller unit and heat exchangers are used to provide the desired fluid temperature at the demineralizer inlets for either boron release or storage. Boron content in the letdown stream may be monitored before it is diverted for processing, or after it has been treated by the thermal regeneration process.

2.3.2 Combustion Engineering¹⁶

Figure 2.3 shows the CE CVCS. The one major design difference incorporated in the CE design is a reactor coolant bleed through seal cooling for the reactor coolant pumps, as opposed to the common seal injection designs of Westinghouse and B&W. CE plants also use a dedicated high pressure injection system.

2.3.3 Babcock & Wilcox¹⁷

Figure 2.4 shows the B&W Makeup and Purification System. B&W uses signals from the Integrated Control System to control boron, as opposed to relying solely on process flow. A regenerative heat exchanger to heat the charging flow is not needed since most of the makeup flow is directed to the reactor coolant pump

seals, as opposed to being injected directly into the cold leg. This is a unique design which has

been reliable, though the required valving scheme increases the system's complexity.

Table 2.4 Westinghouse Plants with Boron Thermal Regeneration Capability

PLANTS
Farley 1 & 2
Shearon Harris
Virgil Summer
Braidwood 1 & 2
Byron 1 & 2
Callaway
Catawba 1 & 2
Comanche Peak 1 & 2
McGuire 1 & 2
Millstone 3
Seabrook
South Texas 1 & 2
Vogtle 1 & 2
Wolf Creek

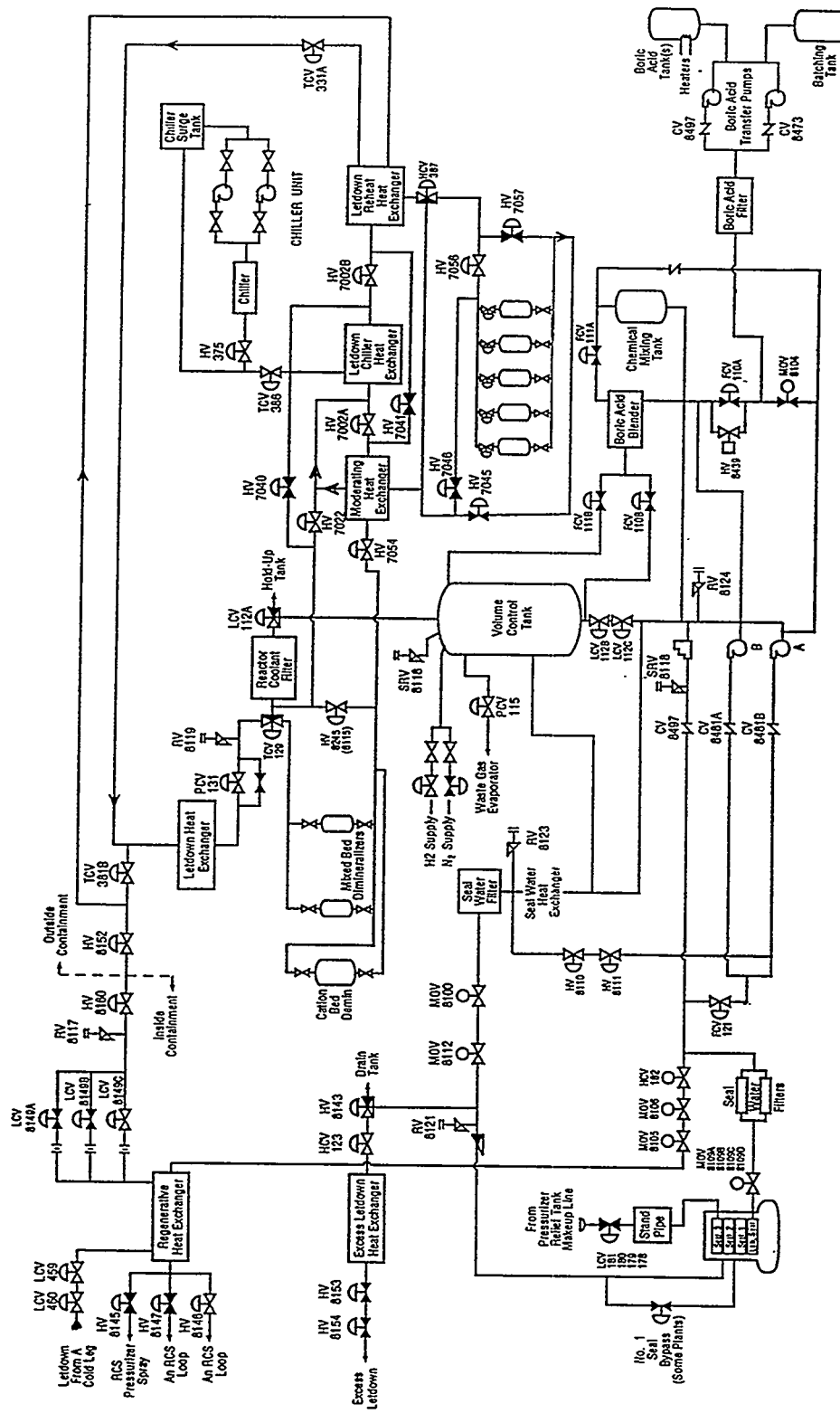

Figure 2.2 Westinghouse CVCS with boron thermal regeneration system

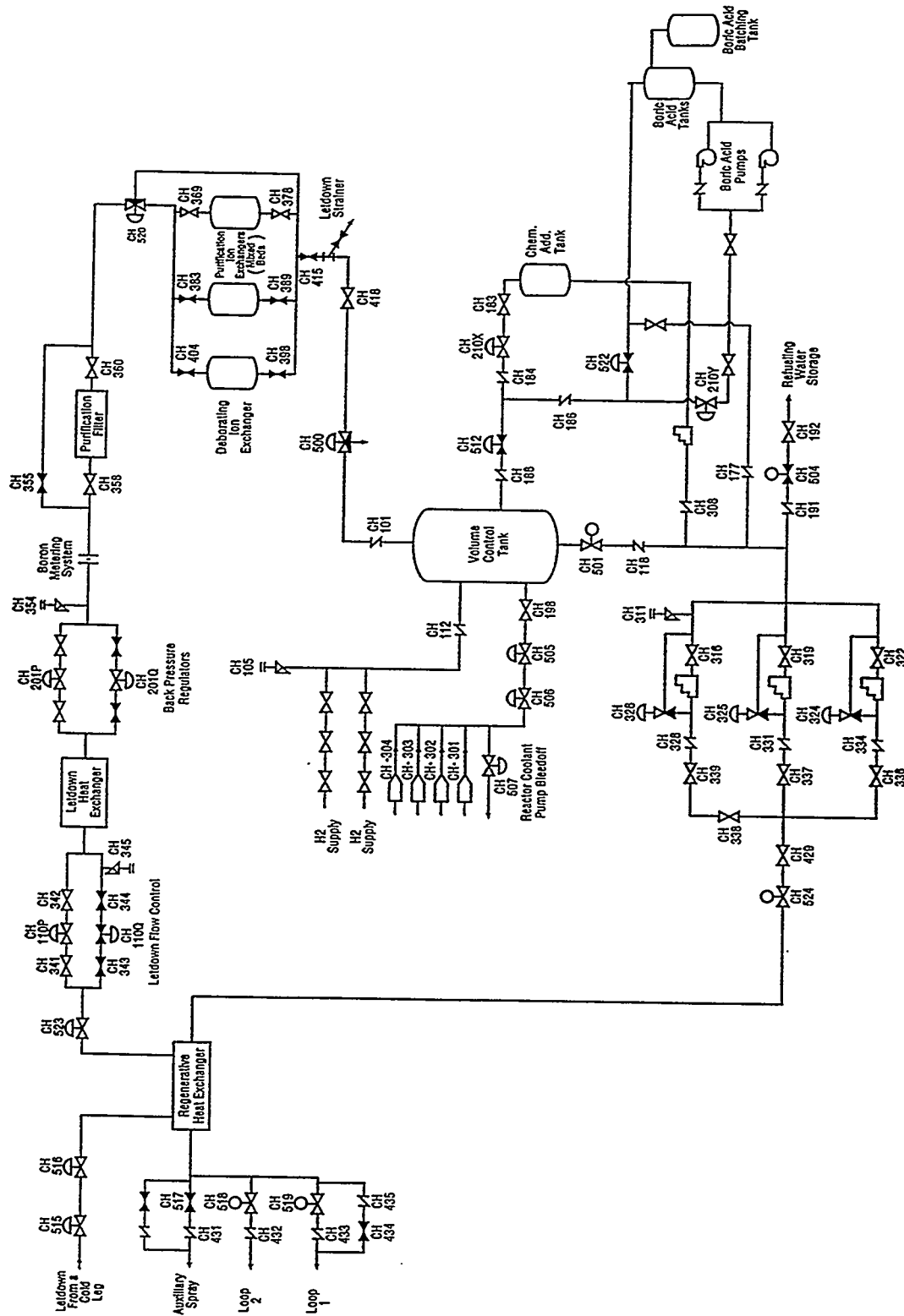

Figure 2.3 Combustion engineering CVCS typical system configuration

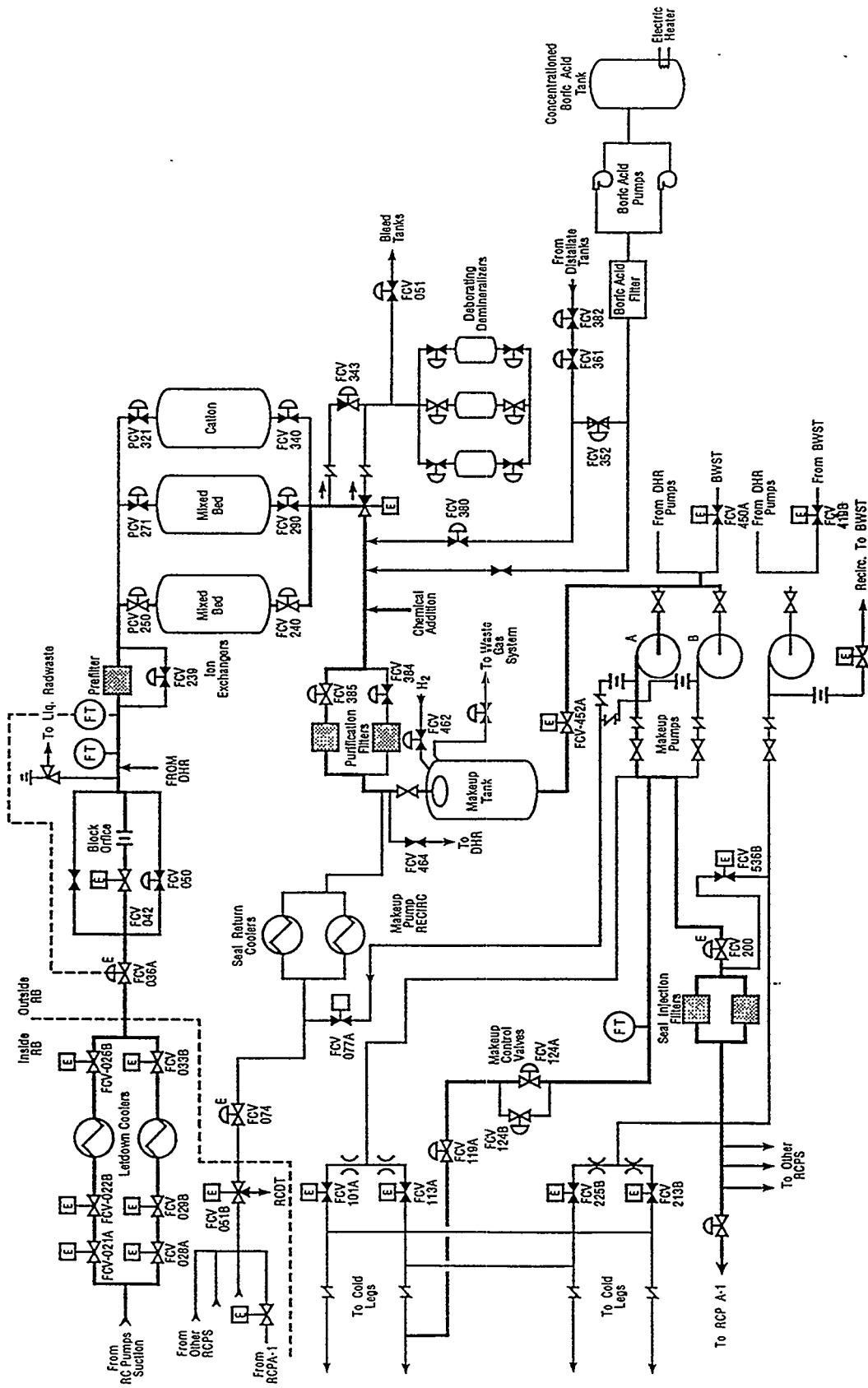

Figure 2.4 Babcock & Wilcox makeup and purification system typical configuration

3. OPERATING AND ENVIRONMENTAL STRESSES

While providing various operating and emergency functions, the PWR CVCS system is subject to a variety of operating and environmental stresses, which over time, may lead to age degradation. These include mechanical, electrical, and environmental stresses, along with stresses induced from human error. Common mechanical stresses include wear, fatigue, vibration, and corrosion. Electrical stresses result from power surges, electrical noise, and instrument drift. Environmental stresses, primarily temperature and radiation, may also result in system and component aging. Externally induced stresses resulting from human error, improper maintenance, and testing may also contribute to the aging process. These stresses, acting in combination, tend to produce greater synergistic effects than if they were acting individually.

Aging failure mechanisms result from the long-term exposure to operating, environmental, and external stresses. Component degradation results in a decrease in the physical properties, and functionality, affecting component operation, and in some instances plant safety. This section describes the individual stresses and potential aging effects for the major system components. Though specific plant system designs may vary, the actual stresses and the aging effects are similar.

3.1 System Operating Stresses

During normal operation, the majority of the CVCS components are required to be operational in order to provide for RCS level control and chemistry control. The remaining components are maintained in standby, including one charging pump, deionizer, and the boric acid transfer system. These components must be maintained to ensure they will operate when needed.

The system operating stresses during normal and emergency operation are:

- **Mechanical Wear:** The physical interaction between the system's sub-components may produce significant frictional forces. Over time, these forces may produce material wear, galling, fretting, or binding. Valve seat and disc wear, and pump impeller and piston wear are typical examples for the CVCS.
- **Cyclic Fatigue:** Cyclic fatigue results from the application of repeated loads. High cycle fatigue results from vibration due to high-frequency loading at low amplitudes. The vibration resulting from positive displacement pump operation produces vibrations which may cause cracks in suction and discharge piping.
- **Debris and Crud:** Debris and crud, originating throughout the primary system, may be transported and deposited in any of the system's components. Resin carryover from the deionizers may block the flowpath in the system filters, valves, and heat exchangers restricting flow.
- **Emergency Actuations:** In many plants, the CVCS also provides high pressure injection in emergency situations. This actuation results in the sudden start of standby centrifugal pumps, the rapid closing of containment isolation valves, and realignment of the suction flow from the VCT to the RWST. In addition to presenting challenges to the operation of these components, ESF actuations also challenge other plant safety systems, which also may contribute to age degradation.
- **Boric Acid Corrosion:** High concentrations of boric acid solutions are required to be maintained for rapid control of reactivity in emergency situations. Primary coolant leakage which contains boric acid may cause corrosion of carbon steel components.

- **Electrical Surge:** Electrical transients, resulting from disturbances in the current supplied to pumps and valves in the system, can cause system faults, spurious operation, and aging degradation.
- **Electrical Noise and Drift:** Electrical noise and drift may produce electrical circuit perturbations. If not detected and corrected, spurious component actuation and aging degradation may occur.
- **Vibration:** Vibration caused by either coolant flow or component operation may result in physical motion of components. This displacement may lead to wear, crack initiation or growth, galling, and component failure.
- **Maintenance:** Normal, regularly scheduled maintenance, designed to maintain the operability of components and of the system may place stresses on individual components.
- **Testing:** To ensure the operational readiness of those components required to provide high pressure injection, quarterly system testing is required. These tests range from valve actuation, to establishing flow from the charging pumps. Over the 40-year design life of the system, these tests result in a considerable amount of stresses. The characteristics of the required test also may be detrimental to the component. For example, operating the pumps in minimum flow mode may cause pump damage and failure.
- **Human Error:** To maintain the operational readiness of the system, numerous tests and inspections are required. Human error in performing these tests may result in coolant chemistry fluctuations, or spurious component actuation, generating mechanical and electrical stresses, which can accelerate age degradation.

3.2 Environmental Stresses

Temperature is the primary environmental stress which can affect CVCS operation. A review of plant operating experience indicates that the system is susceptible to elevated temperatures. However, the majority of the components are outside the containment, where temperatures are relatively low. The system has not shown a susceptibility to other environmental stresses, such as radiation and humidity, again because they are located outside the containment, in relatively cool and low radiation areas.

The two components which are most susceptible to high temperatures are the charging pumps and the demineralizers. A chiller is located in the pump room to dissipate the heat generated from pump operation. This chiller is required to be functional, and if not, corrective measures must be taken in a timely manner, or the pumps removed from service. High letdown fluid temperature may also result in improper demineralizer operation. High fluid temperature will result in the premature degradation of the resin, resulting in high coolant chemistry contaminant and boron levels, and potential operating transients.

3.3 Effect of Operating and Environmental Stresses on System Components

As discussed in Section 2, the CVCS system is comprised of various fluid handling components (i.e., pumps, valves, heat exchangers, demineralizers) which are used for both normal operating and emergency conditions. Each component is subjected to mechanical, electrical, and environmental stresses of varying intensity, frequency, and duration.

This section describes the primary operating and environmental stresses which affect the main system components. Table 3.1 summarizes the potential degradation mechanisms, failure

**Table 3.1 CVCS Component Potential Degradation Mechanisms,
Failure Modes, and Detection Methods**

Component	Aging Stressors	Degradation Mechanism	Failure Mode	Failure Detection Methods
Charging Pumps •Centrifugal •Positive Displacement	Operating transients Maintenance Testing Normal operation	Mechanical Wear Vibration Fatigue Corrosion Flow Blockage Electrical Transient	Failure to start Failure to run Primary Coolant Leakage	Visual inspections Operating tests •Speed •Flow •Differential pressure •Vibration •Temperature •Lube Oil Monitoring
Valves •Motor-operated •Air operated •Check valves	Operating transients Maintenance Testing Normal operation	Mechanical wear Flow blockage Corrosion Electrical transient Flow induced vibration	Internal leakage External leakage Failure to open Failure to close	Visual inspections Operating tests •Position verification •Stroke time •Flow verification
Heat Exchangers •Regenerative •Non-regenerative	Operating transients	Flow blockage Corrosion Tube leaks	Internal leakage External leakage	Operating tests •Inlet and outlet flow •Pressure drop •Outlet temperature
Volume Control Tank	Operating transients Fabrication deficiency Normal operation	Corrosion Flow blockage	External leakage	Operating tests •Level monitoring •Pressure indication

modes, and inspection methods which could detect these potential failures.

- **Pumps:** The CVCS charging pumps, and boric acid transfer pumps are subjected to numerous mechanical and electrical stresses during operation. These stresses, over time

may lead to mechanical wear, primarily of the impeller and piston. Operating experience has shown that positive displacement pumps run rougher than centrifugal pumps, and the resulting vibration may cause fatigue failures. Both the charging and boric acid transfer pumps

are susceptible to flow blockages and corrosion from the highly concentrated boric acid. Performance of the required maintenance and testing on the pumps, particularly on the charging pumps may also be a source of stress. The primary failure detection methods include visual inspections for coolant leakages, and operating tests to monitor and trend the pump operating characteristics.

- Valves: The CVCS utilizes various types of valves (e.g., check, motor-operated, air-operated) to perform the desired operating and containment isolation functions. All valves are subject to corrosion and flow blockage due to boric acid precipitation. Flow-induced vibrations may result in wear on the check valve internals. These stressors may result in internal leakage past the seat or external leakage. Valve operability and position verification are the primary means of assuring operability.
- Heat Exchangers: A series of heat exchangers is used to reduce the temperature of the letdown flow. This temperature reduction is necessary for

proper operation of the demineralizers. Regenerative heat exchangers are used in several plants to increase the temperature of the charging flow to minimize the risk of thermal shock. Operating transients which result in flow blockage, corrosion, or internal tube leaks may result in degraded operation. Operating tests to measure the temperature reduction, and output flow and pressure are the primary means to assess operability.

- Volume Control Tank: The volume control tank is used as a holding tank for the excess letdown flow. It also maintains the hydrogen overpressure, which is absorbed by the reactor coolant, and allows for the scavenging of any free oxygen in the core. The tank is fabricated from Austenitic Stainless Steel to resist corrosion. Operating transients resulting in the overpressurization of the tank, operational problems causing a vacuum, and fabrication deficiencies resulting in external leakage are the primary degradation mechanisms. Tank instrumentation (level and pressure) and visual inspections are the primary monitoring methods to ensure integrity.

4. CVCS OPERATING EXPERIENCE

4.1 Introduction

A primary objective of this study was to assess the impact of aging on the PWR CVCS. To accomplish this, the individual component and system failures were reviewed. As defined in NUREG-1144, the following criteria must be satisfied for failures to be classified as aging related:

The failure must be the result of cumulative changes with the passage of time, which if unchecked, could result in the loss of function and impairment of safety. Failures causing aging include:

- a) natural, internal, chemical, and physical processes which occur during operation,
- b) external stresses (radiation, heat, humidity) caused either by storage or operating environments.

In addition, to eliminate failures due to "infant mortality", the component must have been in service for at least six months.

A review of the operating and failure history for each of the PWR CVCS designs suggest that each has experienced age degradation (>50%) with varying plant and system effects. This data was obtained from two sources of information on nuclear plant operating experience:

- 1) Nuclear Plant Reliability Data System (NPRDS), and
- 2) Sequence Coding and Search System (SCSS).

The NPRDS is a computerized information retrieval system maintained by the Institute of Nuclear Power Operations (INPO). Performance information provided by this system is based upon failure event reports of key components submitted by the nuclear utilities. NPRDS gives access to historical engineering

data reflecting a broad range of operating experience.

The Sequence Coding and Search System (SCSS), also known as the LER data base, provides summaries for each LER. These entries supply information on the failed components mentioned in each LER, the root cause of the failure (if known), and the effect upon plant operation.

Both databases were searched for CVCS failure data. The LER database contains information primarily on failures which occurred during plant operation. The NPRDS database contains component failure data found during maintenance and outages, as well as during operation. There is duplication in the data bases; however, it was important to review both to obtain an understanding of all the reported failures. Due to the voluminous amount of data in these databases for the 1980-1991 time period, a detailed review was limited to the 1988-1991 period. This also limits the data to the post-1984 period when the LER reporting requirements were revised, and the NPRDS contents became more thorough. In addition to the failures reported to the databases, plant visits were conducted to obtain additional information on system aging. The results of these visits is presented in Section 6.

Figure 4.1 shows the total number of CVCS failures contained in these databases for this period. The actual number of failures reported to the NPRDS greatly exceeds the number of LERs (3384 vs. 645). The number of failures reported to the NPRDS exceeds that reported on LERs because most CVCS failures were found during regularly scheduled maintenance and inspections, and did not result in plant operating effects.

Based upon a review of the information obtained from these searches, it was concluded that failures affecting each of the main sub-components were reported. Figures 4.2 and 4.3

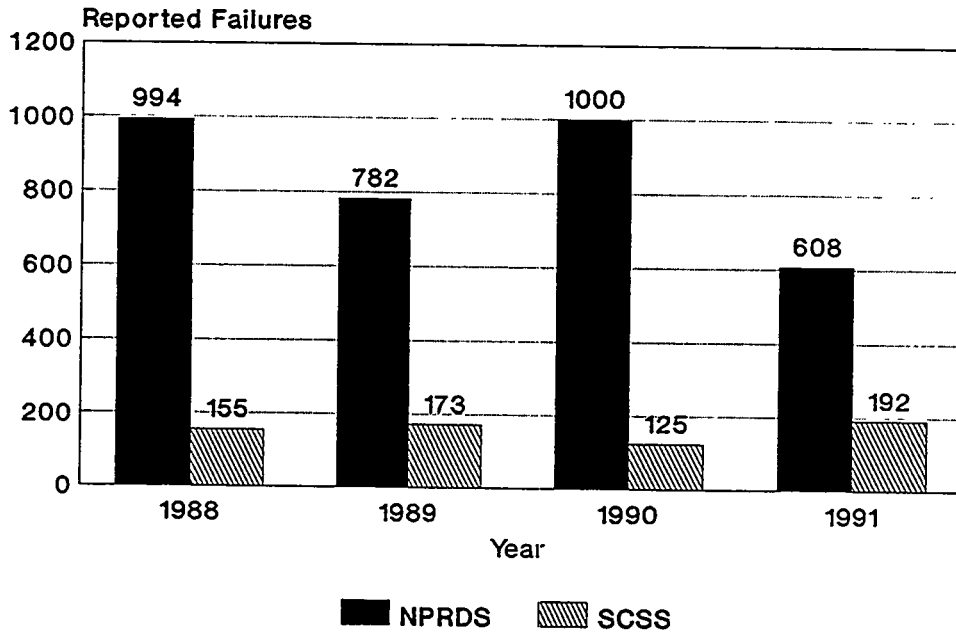

Figure 4.1 CVCS failure occurrences

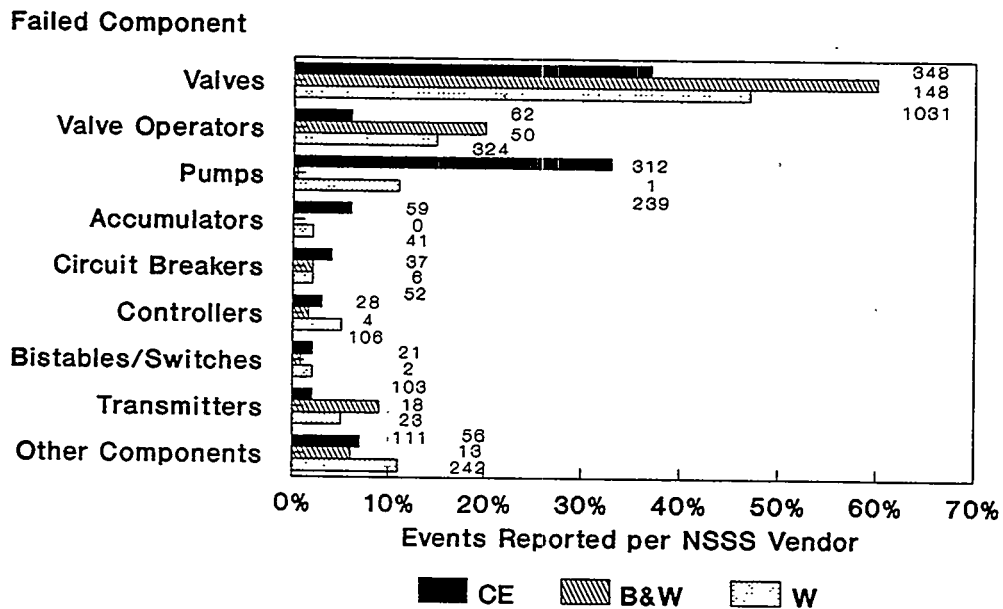

Figure 4.2 CVCS component failures reported to NPRDS

Failed Components

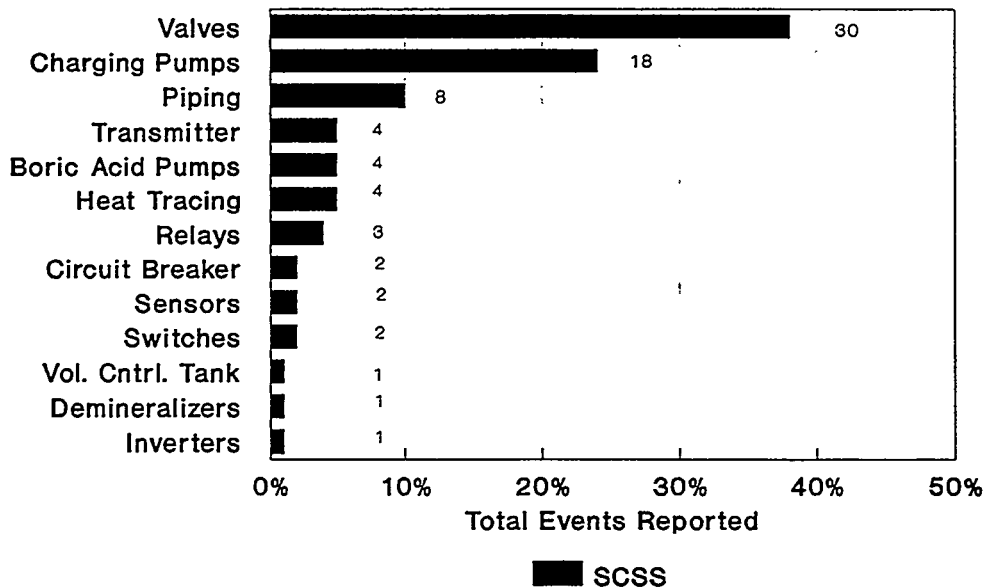

Figure 4.3 CVCS component failures reported to SCSS

show the percentage of total failures for the system components as reported by the NPRDS and the SCSS databases, respectively. Though the actual number of failures differ between the two databases, the same components were identified, with pumps and valves being the most frequently reported. In a fluid control system such as the CVCS, which is predominantly comprised of pumps and valves, engineering judgement dictates that these would be the most commonly failed components. Failures affecting the other components (instrumentation, demineralizers, heat exchangers, and piping) were reported, but much less frequently.

While similar component failures were identified in both databases, components (i.e., valve operators) were not specifically identified in the SCSS database. These differences are primarily due to the type of failures contained in each. A review of the valve operator failures indicated that many were identified during regularly scheduled maintenance before their operation was affected. Since no plant operation perturbation resulted, LERs were not written.

As described in Section 2, the primary non-safety related functions of the CVCS are to control the letdown and charging flow, maintain water chemistry, and provide normal boration. Failures affecting these functions could result in significant plant effects including:

- a. loss of normal boration may result in an unanticipated boron concentration transient, which could lead to a reactivity transient,
- b. loss of RCS inventory control could result in a reactor trip on high pressurizer level, or a safety injection signal on low-low pressurizer level and possible RCS thermal shock,
- c. loss of RCS chemistry control could result in a forced plant shutdown due to Technical Specification violation on oxygen, chloride and fluoride concentration limits, and
- d. loss of boron recovery could result in the inability to provide sufficient boric acid and demineralized water makeup for normal boration control.

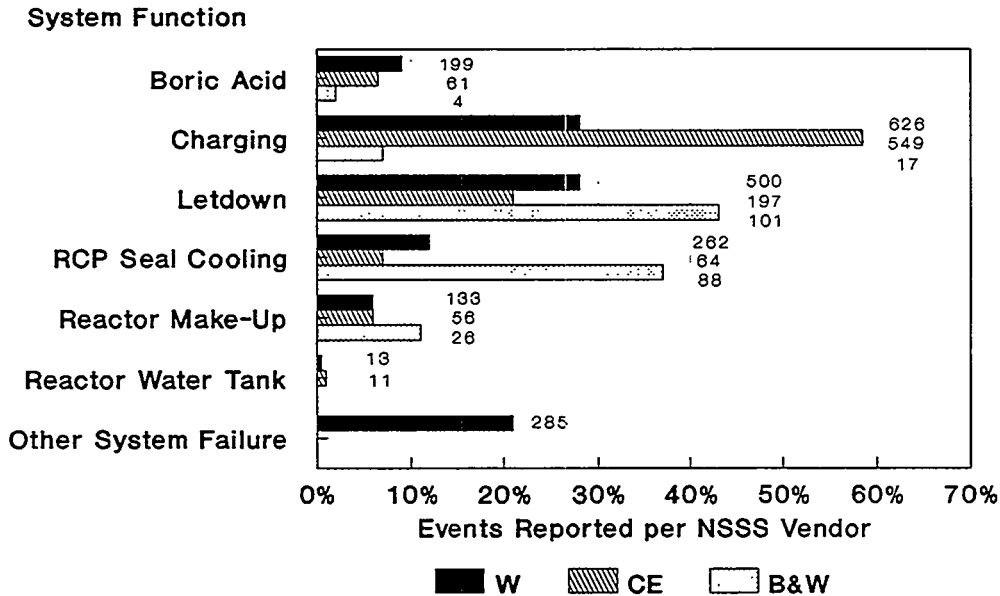

Figure 4.4 System functions affected by component failure

The charging, letdown, and RCP seal cooling functions were the most frequently affected by component degradation (Figure 4.4). As discussed previously, the primary safety function of the CVCS is to provide high pressure injection and emergency boration. HPI aging was not specifically considered in this study and was addressed in a previous NUREG/CR (Ref. 3). However, failures affecting this function, and the components needed to provide it, would be expected to result in more significant plant effects. The failures categorized as other system failures include degradation of CCW, RHR, and HPI systems. These failures were listed with CVCS since the affected components were common to both (e.g., regenerative heat exchangers).

Figures 4.5 and 4.6 show the specific plant and system effects resulting from these component failures. The two most common effects were inoperable components and the loss of a particular sub-system train. Again, due to the redundancy designed into the PWR CVCS system, the effects on plant operation were minimal, and those which did occur, were detailed in the SCSS database. A major effect

common to all the failures, though not readily discernable from the LERs, was loss of redundancy. As described, the system is designed with multiple components and flowpaths to ensure continuous operation in the event of failure. Provided these alternate components and trains remain functional, such failures are not critical, however, in the event of a failure of the redundant component, the potential effect could be more severe, and affect plant operation (i.e., reactor coolant chemistry variations, and pressurizer level changes).

One area where there was a large discrepancy was in the number of failures attributable to aging. As shown on Figure 4.7, the majority of failures contained in the NPRDS database were found to be aging, while the majority of failures in the SCSS database were non-aging related (Figure 4.8). Again this may be explained through the redundancy built into the system. Failures of the CVCS typically did not affect plant operation; therefore, many of the LERs were based on design discrepancies, missed surveillances and inspections, and system actuation due to other system failures or degradation. CVCS component failures did not

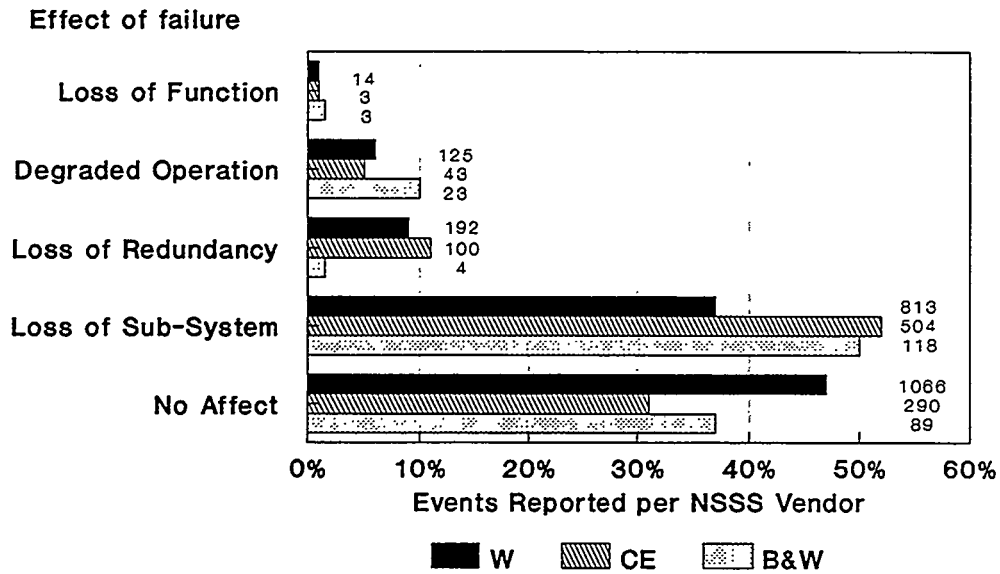

Figure 4.5 Effect of failure (NPRDS)

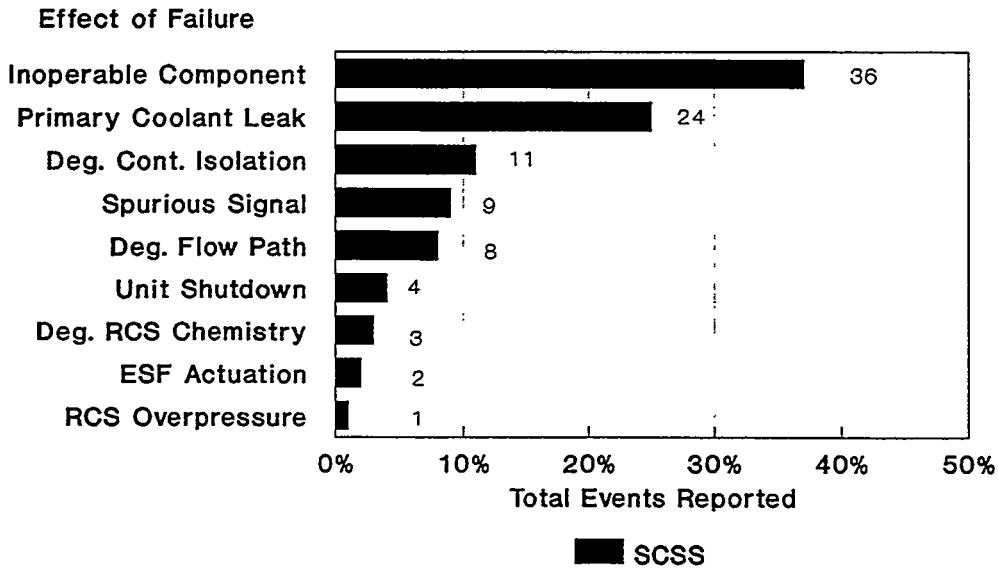

Figure 4.6 Effect of failure (SCSS)

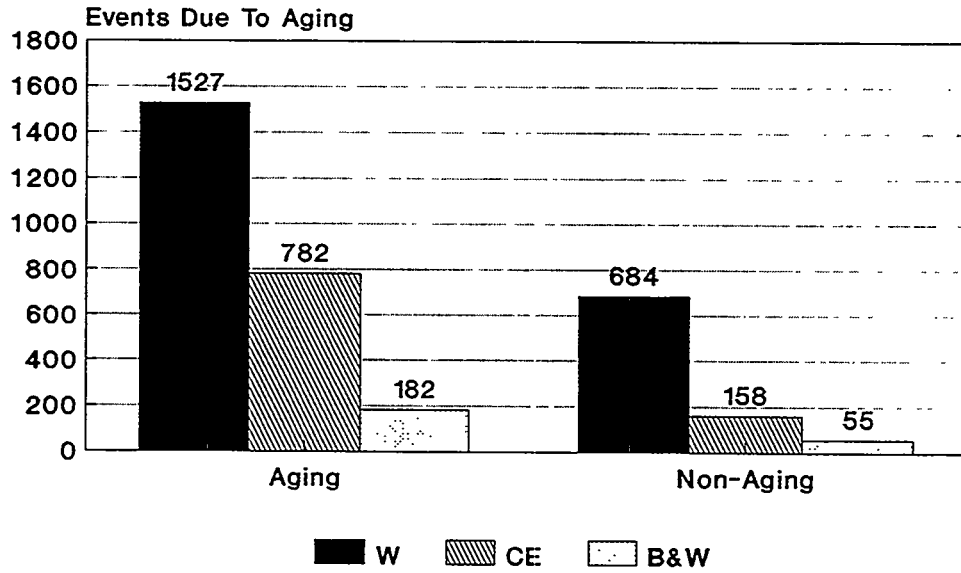

Figure 4.7 CVCS failures attributable to aging (NPRDS)

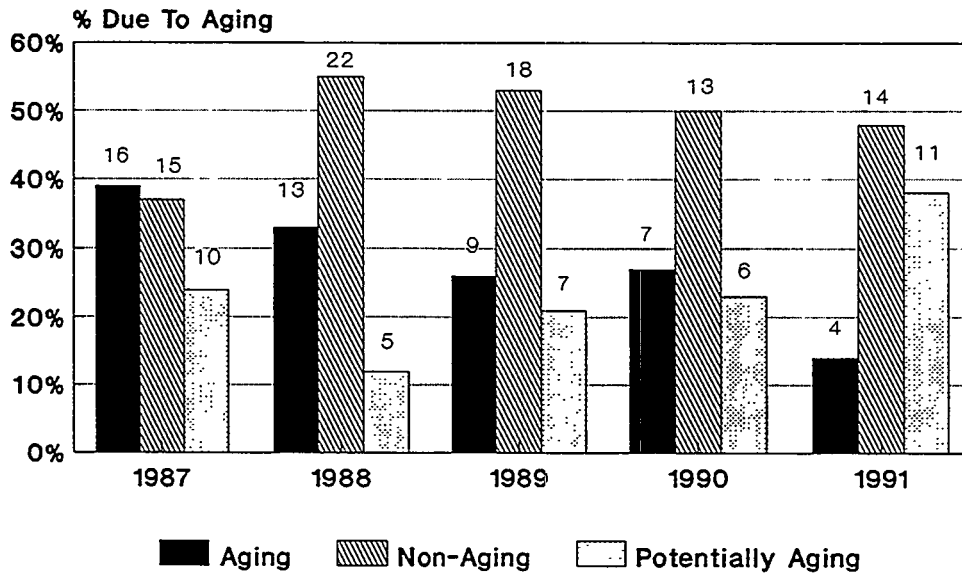

Figure 4.8 CVCS failures attributable to aging (SCSS)

typically result in an LER. Conversely, the NPRDS database reported all component failures and degradations regardless of the effect.

Information on the failure of specific components obtained from reviewing the two databases is discussed in greater depth in the following sections.

4.2 NPRDS Failures

4.2.1 Valve Failures

Among the individual sub-components in the PWR CVCS system, valve failures accounted for the majority of system failure occurrences (1533 total). Depending upon the specific function, various types of valves and actuators are used. As shown in Figure 4.9, most reported valve failures and degradations affected gate and globe valves. A review of the various system designs for the PWR CVCS indicate that these types of valves are commonly used throughout the system to either isolate or direct flow through the major sub-components. Therefore, the relatively large number of failures for these valve types may be attributed to their population. Other valve types (e.g., check, diaphragm, butterfly, etc) were used less frequently, and accounted for less than 10% of the failures. Figure 4.10 shows the particular operators for these failed valves. The majority of these failures affected manual, motor-operated, pneumatic, and mechanical valves. Mechanical valves (e.g., relief valves) use spring force and differential pressure to open and close. The review of the operator type indicates that the valve failures were not restricted to one type of operator.

In the NPRDS database, the age of the valve at failure coincides with plant age. To account for component population variations within each of the age categories, this data was normalized by unit-years of operations. As shown in Figure 4.11, the number of failures per unit-year show an initial rise up to 5 years of service, then demonstrate a steady decline out to 15 years. This trend continues for CE, however, for W

and B&W plants, an increase in failures is seen. The exact cause for these trends is not discernable from the data; the decrease in failures probably reflects the positive results from increased valve maintenance and surveillance. As the monitoring programs become more sophisticated, the number of valve degradations reported may also increase. Nevertheless, licensees should monitor this trend to ensure that some unknown, or undetected type of aging degradation is not occurring in these older valves. The design life of a particular valve depends upon many factors, including its design and service environment. An increasing trend of failure with age may indicate aging degradation mechanisms discussed in Section 3, including the effects of boric acid and coolant chemistry variations. Valve seat degradation, packing failures, and other mechanical degradation of the valve internals could also be affected by these system conditions.

To determine if valve failures were caused by the aging of any particular sub-component(s), each of the individual failure records was reviewed to identify the specific sub-component that failed. This level of information was found to be contained only in the NPRDS failure narratives. As shown in Figure 4.12, degradation and failure of valve packing accounted for the majority of the failures. These failures were significant because they resulted in reactor coolant leakage. Other sub-components which failed frequently included valve gaskets, seating surfaces, valve stems, and valve internals. Other failures were caused by random failures (< 5%) of fasteners, bellows, seals, and valve discs.

Internal and external leakage from the failed valves was the most commonly reported mode of failure (Figure 4.13). While these failures typically did not affect valve operation, the reactor coolant presented a radiological hazard, a potential corrosion source due to the boric acid, and a potential small break LOCA if the leak was not corrected in adequate time.

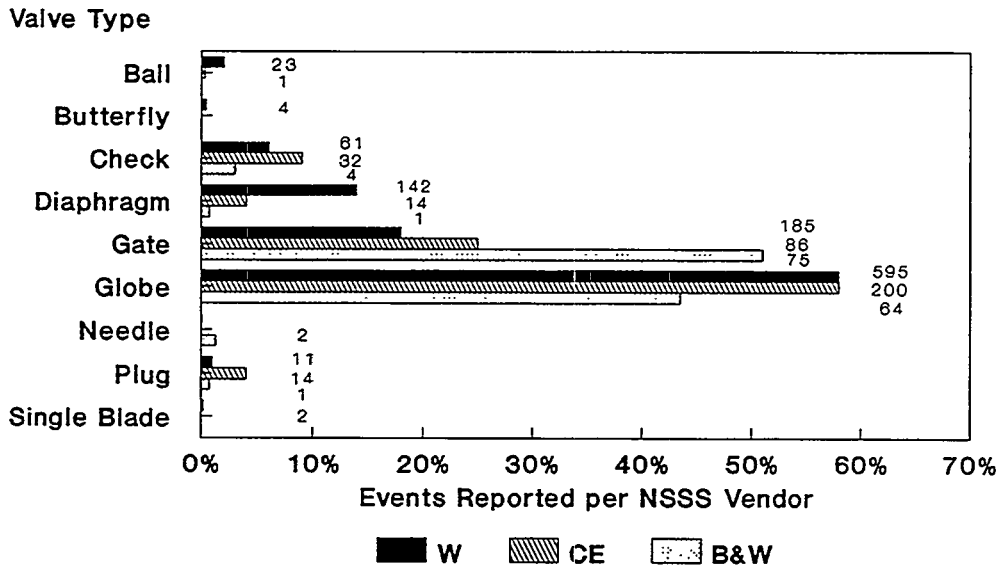

Figure 4.9 Valve failures vs. valve type (NPRDS)

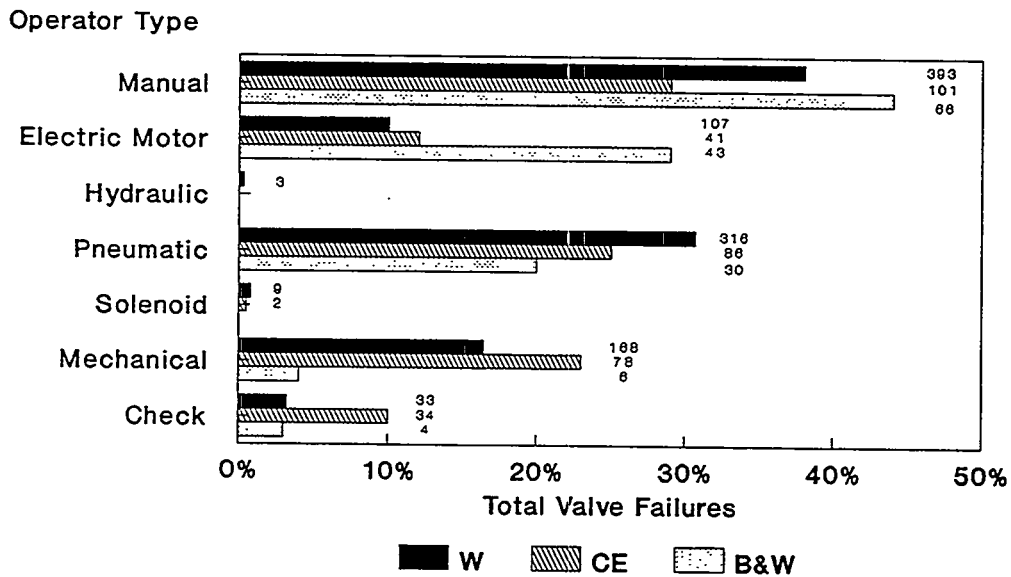

Figure 4.10 Valve failures vs. valve operator (NPRDS)

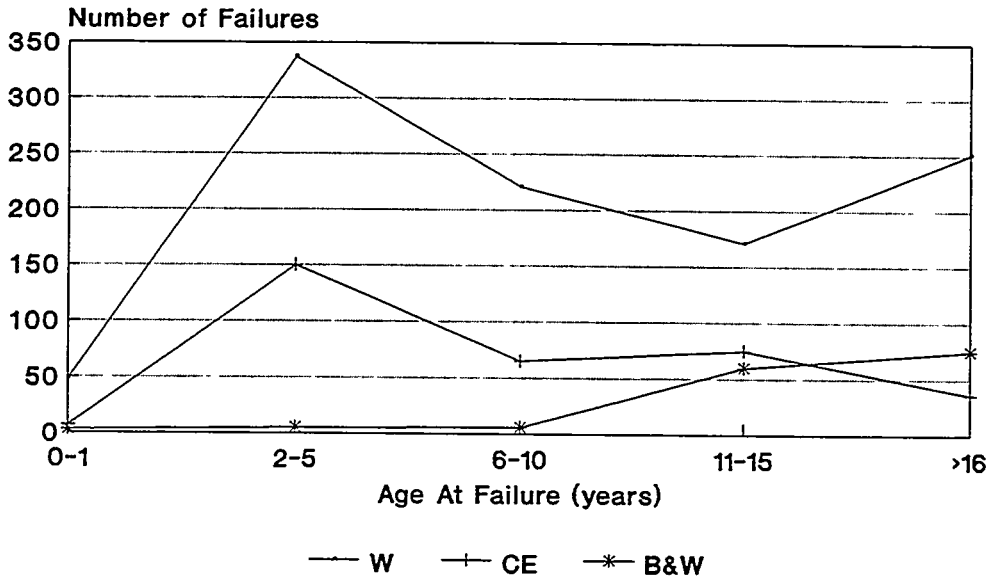

Figure 4.11 Valve age at failure (NPRDS)

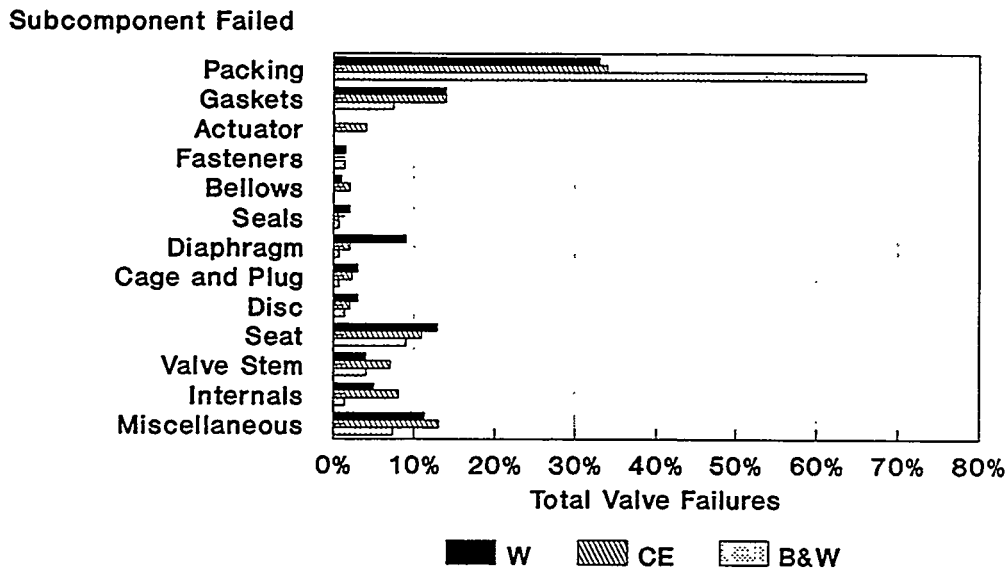

Figure 4.12 Valve failures vs sub-component failed (NPRDS)

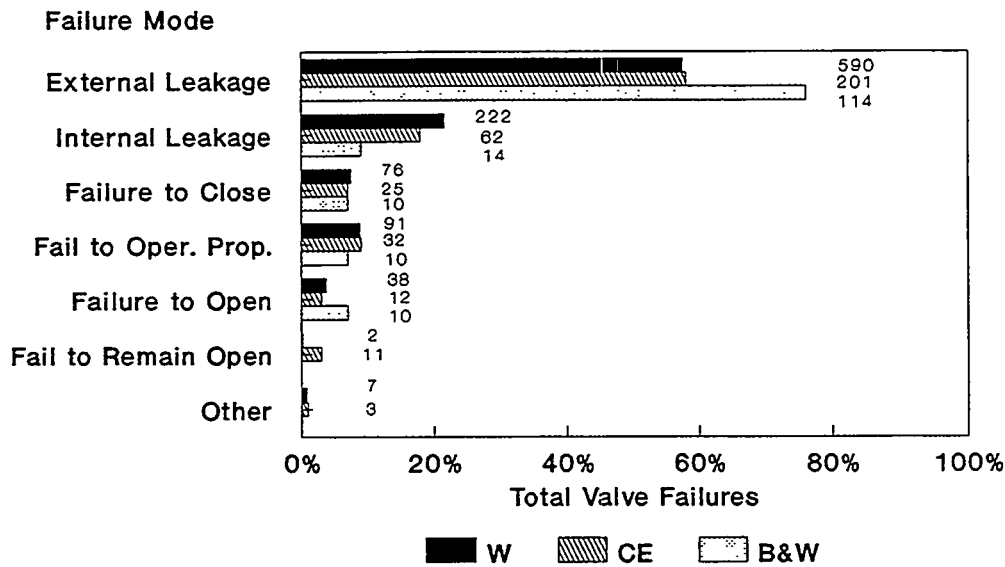

Figure 4.13 Valve failure modes (NPRDS)

Internal leakage potentially could present an operating stress to other components (i.e., pump backflow) or a decrease in reactor isolation if it was a containment isolation valve. The other modes of failure were functional and affected the valve's operation (failure to function on demand, remain in the design position, or spurious operation).

The reported failure causes were reviewed to determine the effect of aging on the failed valves. Of the 14 failure causes identified on Figure 4.14, the first 10 were determined to be potentially aging-related resulting from valve operation or environmental stresses. Mechanical wear (both normal and abnormal) accounted for most of the reported valve failures. Mechanical binding and aging accounted for an average of 10% of the reported failures. Mechanical binding may be due to excessive wear or thermal stresses. Component out of adjustment may be due to instrument drift for electronic components, or lack of lubrication or vibration for mechanical components. Other various aging failure causes accounted for 10% or less of the failures.

The valve failures which were not aging related were caused by incorrect maintenance, procedural errors, or installation of the incorrect part. However, the significance and effect of these failures, was similar to aging failures. A review of the corrective actions in response to the reported degradations (both aging and non-aging) indicate that over 80% were repaired in place by part replacement or repair, or recalibration and adjustment (Figure 4.15). Less than 10% of the failures required valve replacement (e.g., housing cracks).

4.2.2 Pump Failures

The NPRDS database identified 552 pump failures for W and CE plants; only one isolated pump failure was reported for B&W plants. As described in Section 2, both W and CE designs use a combination of centrifugal and positive displacement pumps, while B&W plants use only centrifugal pumps. Centrifugal pumps are constant speed, constant output flow pumps, while positive displacement pumps are variable speed, variable flow. Normally, in plants designed to use both types of pumps in the

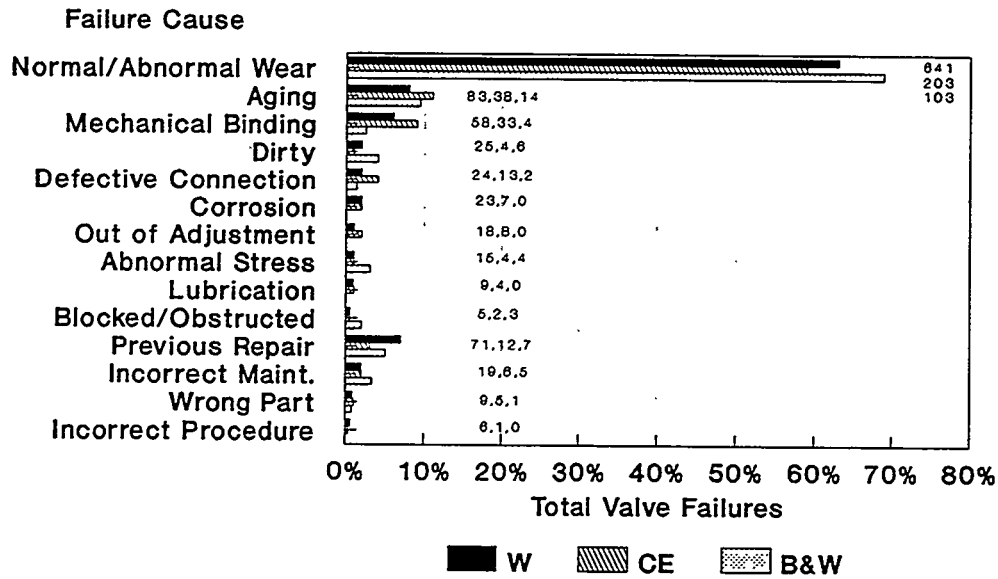

Figure 4.14 Valve failure causes (NPRDS)

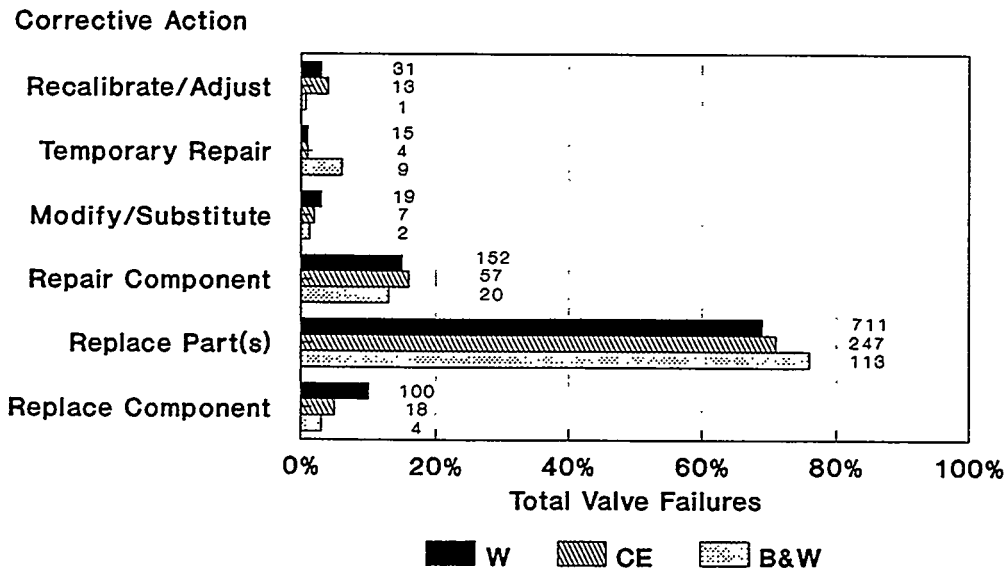

Figure 4.15 Valve failures vs. corrective action (NPRDS)

CVCS, the positive displacement pumps are used to provide the normal charging flow, while centrifugal pumps provide high pressure injection.

As shown in Figure 4.16, almost all of the pump failures reported for the CVCS were for the positive displacement pumps. This would be expected, since failures of the centrifugal pumps would be reported for the High Pressure Injection system, and this information is outside the scope of this study. The typical pump inlet size for these pumps is 2 to 6 inches (Figure 4.17), with only isolated failures reported for large (6-12 inch) pumps. Because of this frequency, the failure data presented in this Section will be for the positive displacement pumps only. Other pump failures, such as boric acid transfer pumps, were not reported frequently to the database.

Figure 4.18 shows pump age at failure, normalized by plant years of operation. For both CE and W plants, a steady rise in the number of reported failures is evident for pumps in service past 10 years, followed by steady decrease in the number of failure occurrences. Similar to valves, these trends may be directly related to the increased surveillance and monitoring. As more is understood about pump aging, and the inspection frequency is increased, and the type of inspections and surveillance methods mature, a rise in the reported failures may be anticipated. However, as these failures are detected and repaired, the number of failures should level out, or decline. The exact cause for the significantly higher occurrence of failures for CE plants is unknown, but may be due to the greater use of positive displacement pumps (and the failures associated with their operation), than Westinghouse.

As shown on Figure 4.19, packing degradation accounted for the majority of pump failures (35% for W, 55% for CE). Packing degradation and failures which result in external leakage generally do not impair the pumps

ability to operate. External leakage is a "pressure boundary" concern, rather than an operational one. An additional 15% of the pump failures were due to failed discharge drain valves, suction manifold check valves, and lube oil system regulating and relief valves. Valve component failures were due to seat, seal, and gasket degradation. Other sub-components which resulted in approximately 10% to 20% of the failures were due to seal failures (o-ring, plunger, and oil), bearing and ring wear, and structural and mechanical fastener failures. CE plants reported 12 pump casing failures due to cracking. Numerous other pump sub-components accounted for the remaining failures. These random failures included impellers, flanges, and valve and discharge springs. No single component failure accounted for more than 1% of the failures categorized as miscellaneous.

The most common failure mode for pumps was failure to run continuously (Figure 4.20), caused by degradation and failure of the individual pump sub-components, discovered during operation, or during quarterly testing. Decrease in output flow, high lube oil temperature, or pump vibration were common indications of pump degradation. In some instances, the pump actually failed, and in others, the plant staff removed the pump from service prior to failure upon detecting an operating abnormality. In both cases, the failure mode was the same. External reactor coolant leakage, primarily from packing degradation was another significant failure mode. Other isolated failure modes included failure to start, and internal leakage from seal degradation. These failures had a minimal effect on plant operation due to the redundancy provided in the system.

Mechanical wear, both from normal operation, and abnormal wear from pump component degradation accounted for over 60% of the failures (Figure 4.21). Other potential aging-related causes of pump failures, include mechanical binding of pump internals, loose

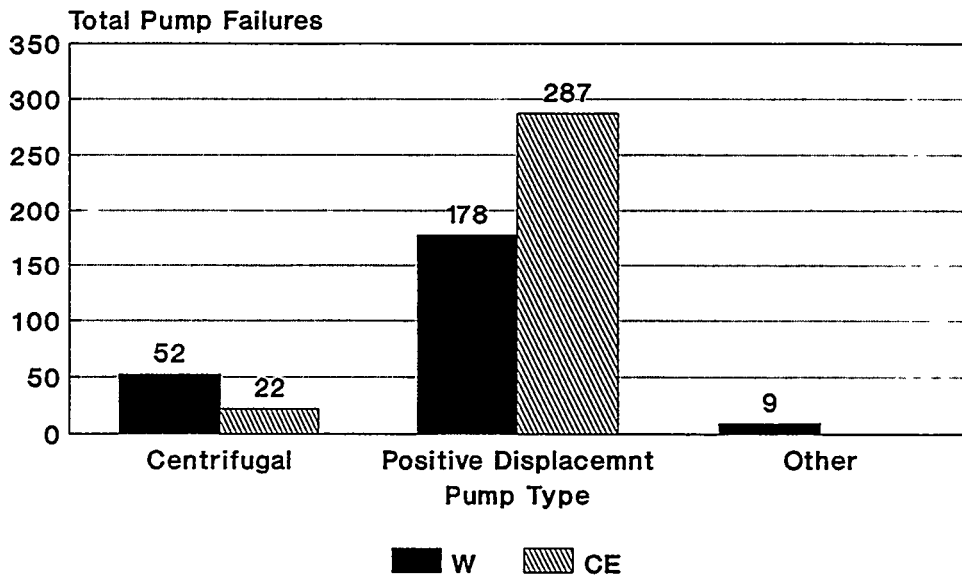

Figure 4.16 Pump type vs. failure occurrence (NPRDS)

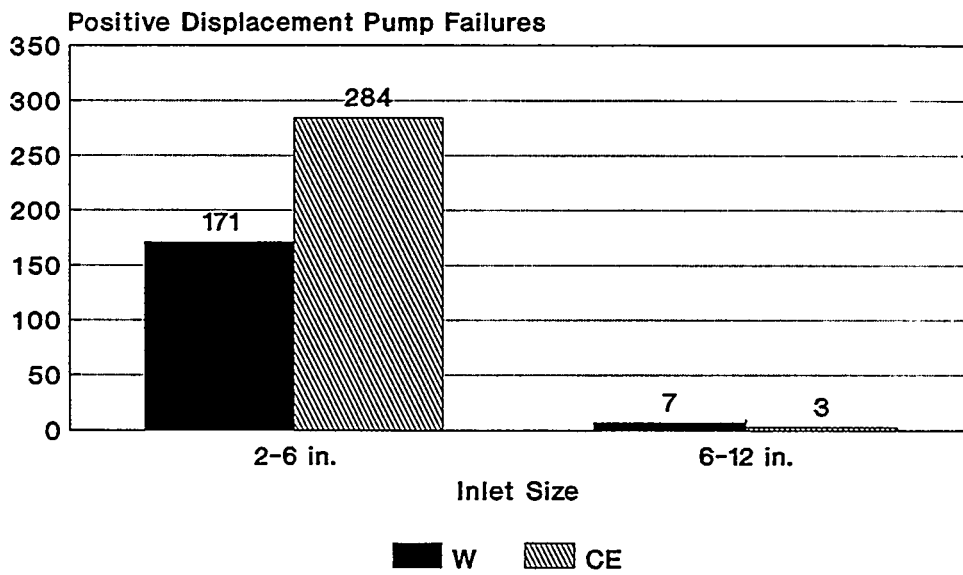

Figure 4.17 Pump inlet size vs. failure occurrence (NPRDS)

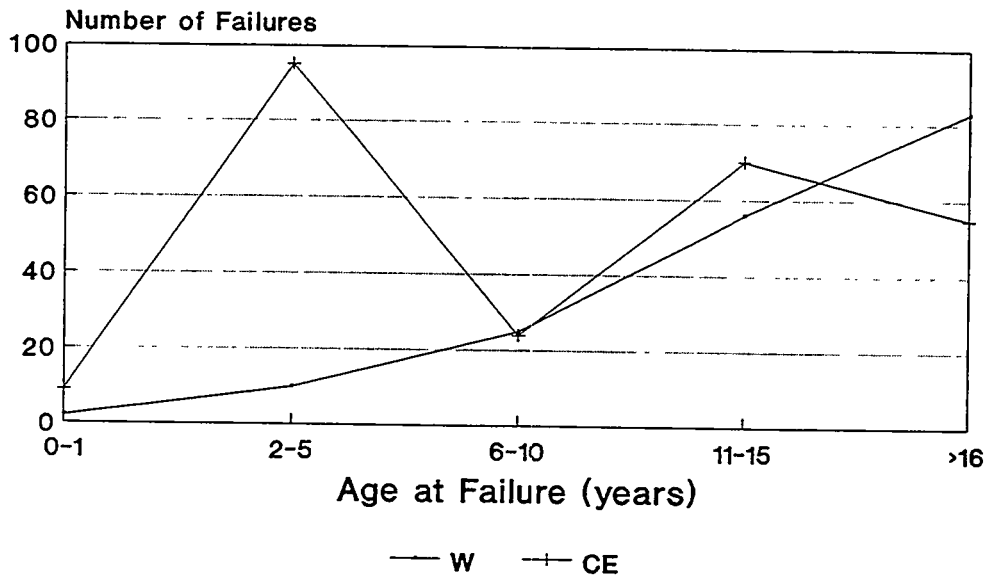

Figure 4.18 Pump age at failure (NPRDS)

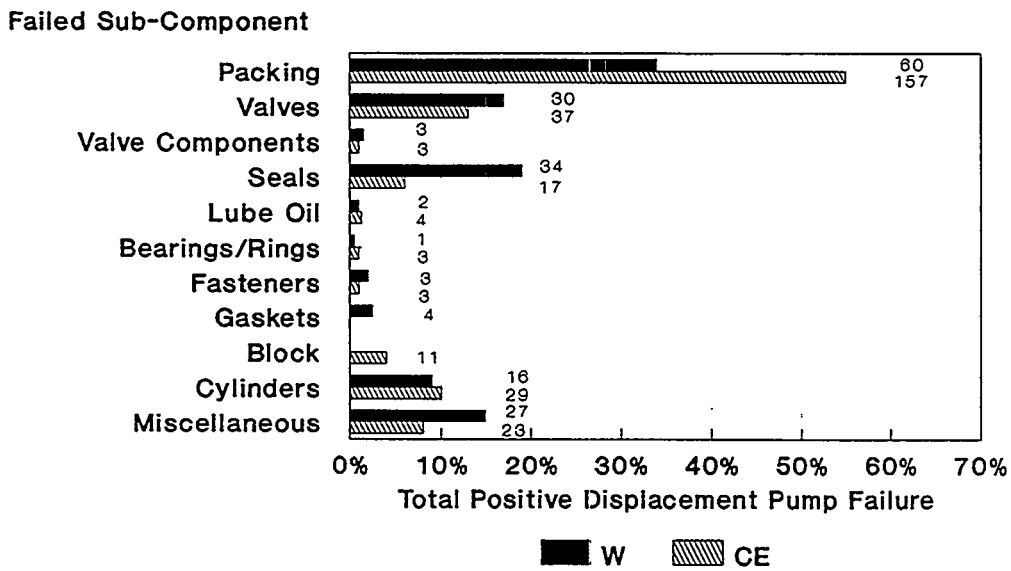

Figure 4.19 Pump failure vs. sub-component failed (NPRDS)

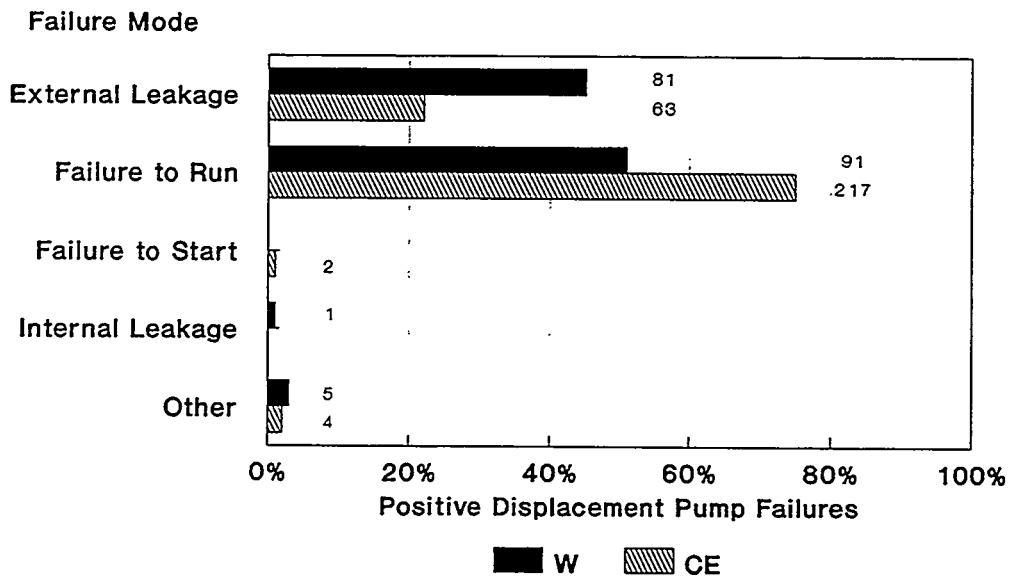

Figure 4.20 Pump failure mode (NPRDS)

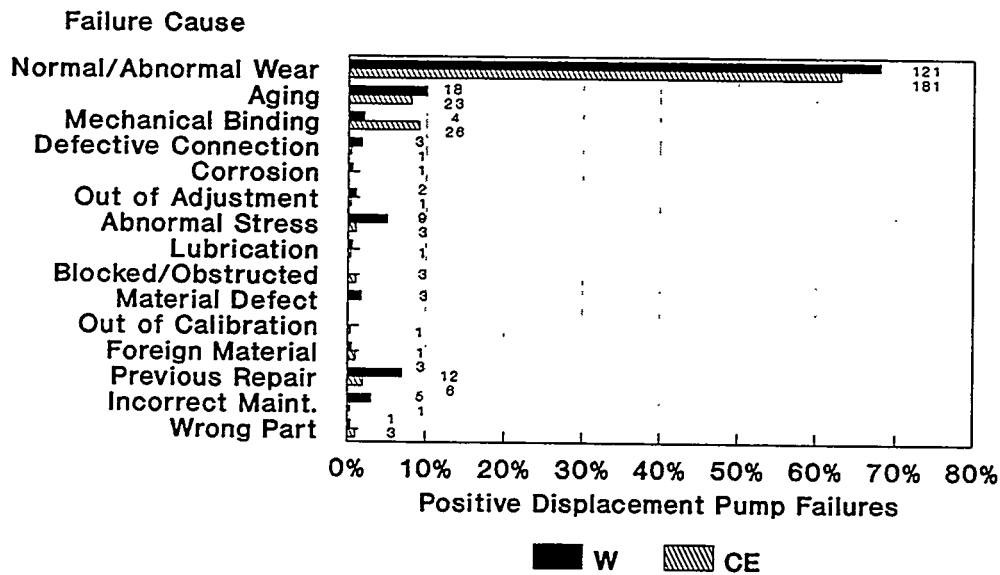

Figure 4.21 Pump failure cause (NPRDS)

pump connections and abnormal stress levels from high mechanical vibration. Combined, these potential aging mechanisms accounted for 90% of the failures. The remaining 10%, which were non aging related, were due to incorrect maintenance, installation of the wrong component, and incorrect or inadequate maintenance. Over 80% of the failures were repaired by temporary adjustments and the installation of replacement parts (Figure 4.22). In only isolated failures (i.e., pump block crack) was the pump replaced.

4.2.3 Valve Operator Failures

The NPRDS reported 436 valve operator failures. As opposed to the valve failures presented in Section 4.1.1, these failures were directly due to degradation of the valve operator, not the valve (i.e., body, stem, disc, bonnet). These operators included AC electric motors, pneumatic, solenoid, and mechanical operators (Figure 4.23). Failures of the air-operated and motor-operated valves accounted for the majority of the failures, primarily because these valve types are commonly used throughout the system.

No consistent trends were discernable when the failures were normalized to account for plant years of operation (Figure 4.24). Initial rises in the number of reported failures, followed by a steady, or declining number of failures were seen from the data. These variations may indicate that the inspection and surveillance programs are not consistently detecting aging degradation and failures. However, the effectiveness of the inspection programs depends upon the function of the valve, and the type of the valve operator. Aging of motor-operated valves are more easily detected than rapid acting air-operated valves, where failures may only be detected by the valve failure to function (open or shut).

Greater than 95% of the valve operator failures impacted valve operation (Figure 4.25). Most occurrences resulted in operational

irregularities, followed by total failure to close or open. Depending upon the valve function and location, these effects could have resulted in a failure to isolate containment or letdown, or to open for charging. External leakage occurred less than 5% of the time, and resulted from seal and gasket degradation between the valve body and the operator.

Approximately 60% of the valve operator failures were rectified by replacing, repairing, or recalibrating and adjusting the degraded parts (Figure 4.26). Compared to valves, the valve operators were more commonly replaced because of the ease in replacing the operator as opposed to the valve itself.

A review of the actual failed sub-components for these failure events indicated that no single component was responsible for a majority of the failures (Figure 4.27). Failed solenoids, diaphragms, air regulators, and other miscellaneous components on the valves accounted for the majority of failures. The cause of the failures was due to mechanical wear between the actuating parts of the operator (Figure 4.28). Significant other causes included mechanical binding, defective and loose connections, and adjustment problems. Approximately 10% of the failures were due to electrical degradation, including shorts, defective and open circuits, and burned out motors. Ten percent of the failures were not aging related, and were due to incorrect maintenance and installation of the wrong part.

4.2.4 Controller Failures

Automatic system operation is one of the primary operating modes for the CVCS. Typically, several CVCS functions are automatically controlled to maintain letdown, charging, and reactor coolant chemistry. Changes are automatically made in response to system changes (i.e., flow, boron content, pressurizer level). Failures of the controllers that accomplish and monitor these functions

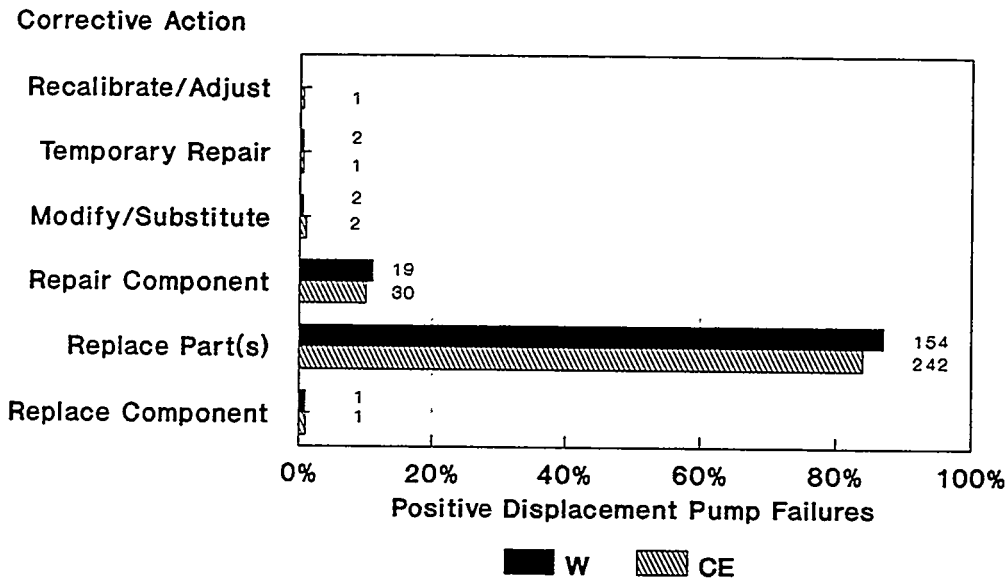

Figure 4.22 Pump failures vs. corrective action (NPRDS)

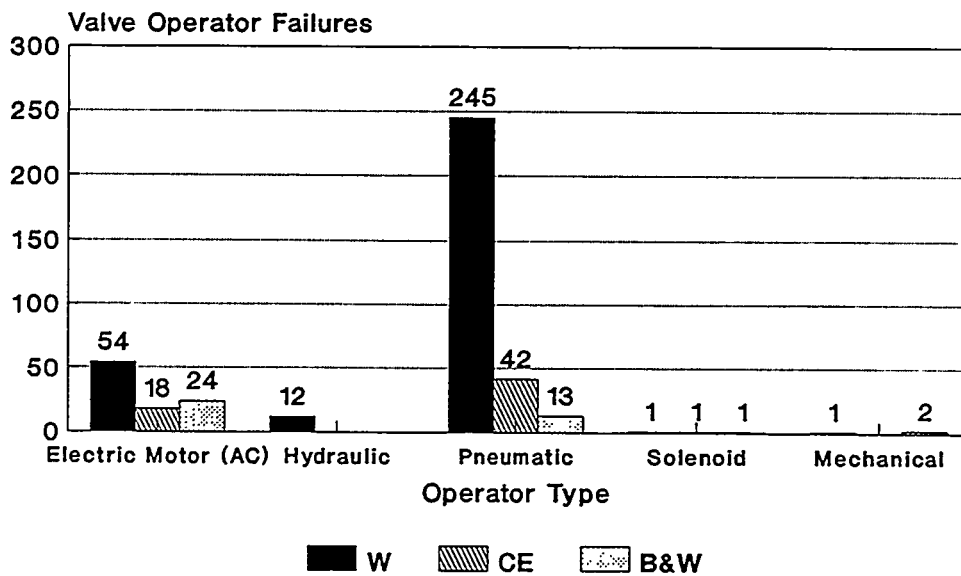

Figure 4.23 Valve operator failures vs. operator type (NPRDS)

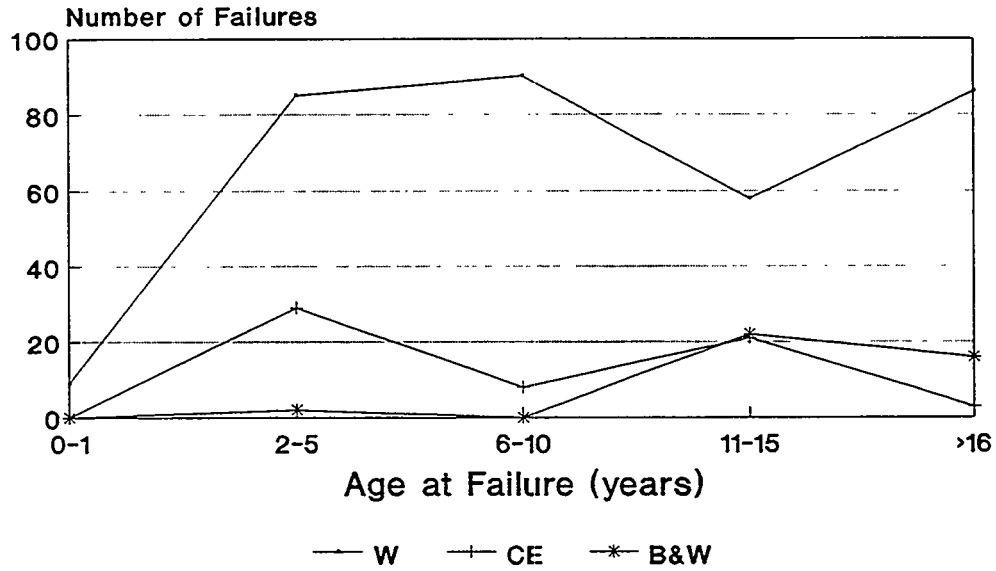

Figure 4.24 Valve operator age at failure (NPRDS)

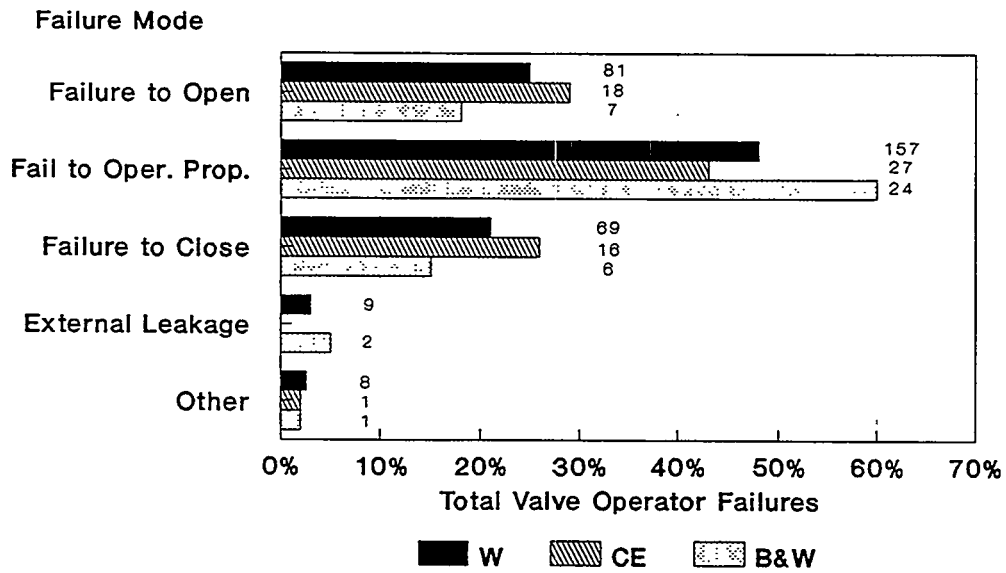

Figure 4.25 Valve operator failure mode (NPRDS)

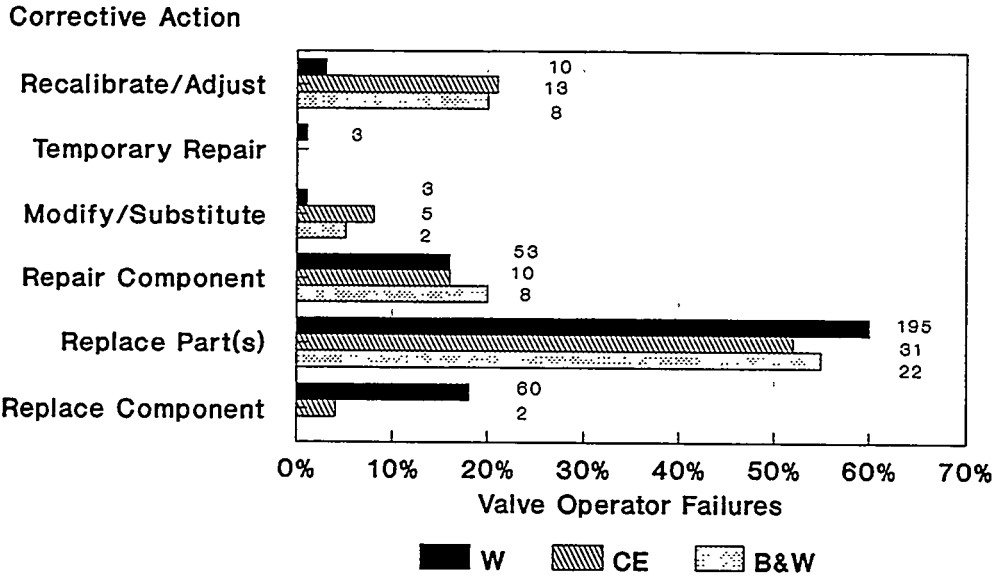

Figure 4.26 Valve operator corrective action (NPRDS)

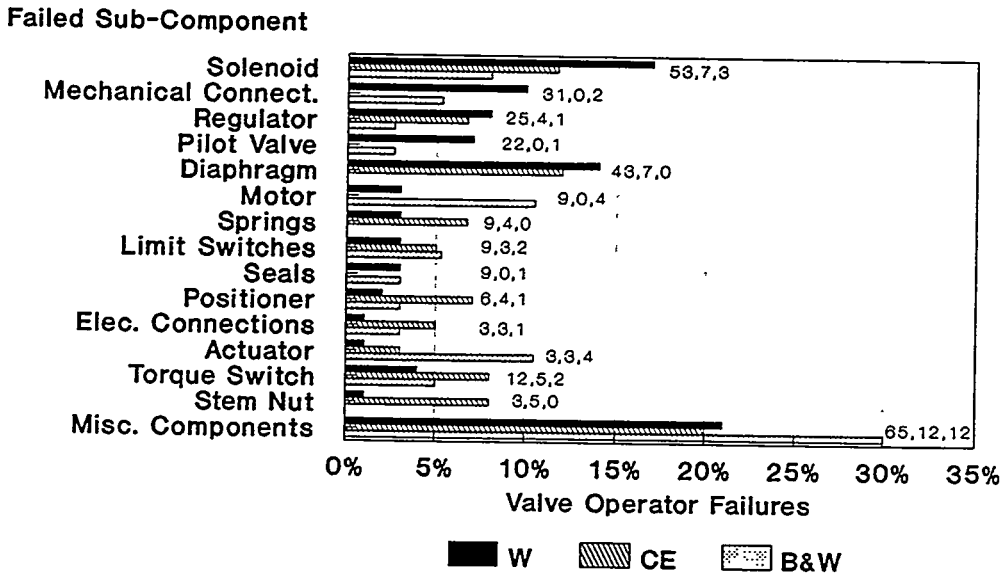

Figure 4.27 Valve operator failure vs. failed sub-component (NPRDS)

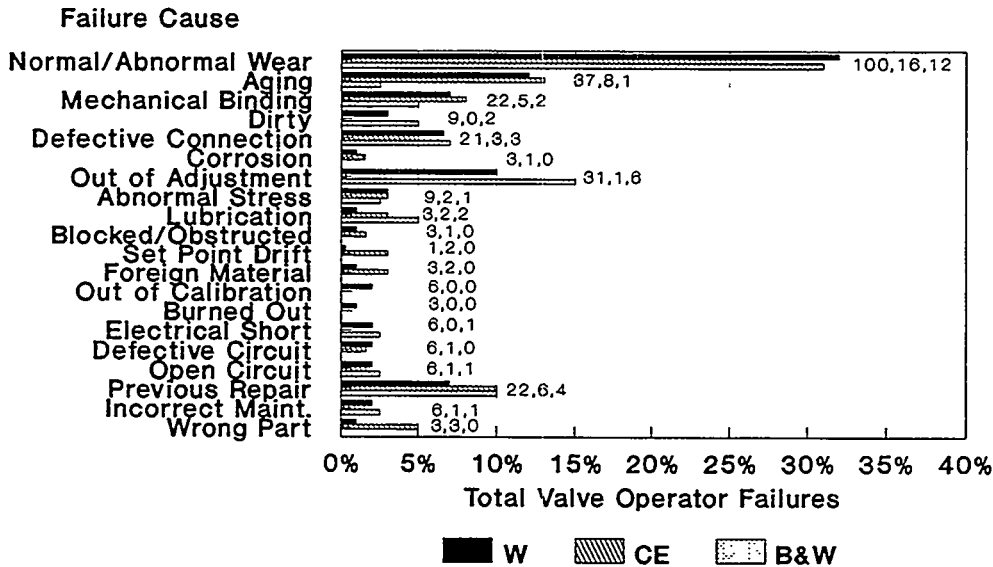

Figure 4.28 Valve operator failure cause (NPRDS)

could result in variations in plant and system parameters, and affect plant operation. As shown in Figure 4.2, controller failures were not common for the period evaluated (<5% of the failures), but because of the potential effect on system operation, the failure data was reviewed to determine their causes and effects.

For the 1988-1991 time period, 148 controller failures were reported, most of which occurred in Westinghouse plants. As indicated on Figure 4.29, these controllers utilized electrical signals (voltage and current) received from system sensors and transmitters. Pressure controllers accounted for an additional 20% of the failures. Only isolated instances of flow rate or tank level controller failures were reported. The primary failure modes for the controllers (Figure 4.30) were loss of, or erratic, output. Less than 10% of the failures resulted in erroneously high or low outputs. A detailed review of the failure narratives did not reveal specific sub-components which failed, typically the failed sub-component was not identified, and the controller that failed was replaced.

Figure 4.31 shows the number of reported controller failures, normalized to account for plant years of operation vs. controller age at failure. Following the first year of operation, a consistent increase in the reported failures at 10 years of operation is seen for both Westinghouse and CE plants, followed by a declining failure rate to 15 years of operation. A steady, or slightly decreasing number of failures is seen for controllers following 15 years of operation. Since the overall failure rate for the controllers is low, and since the actual sub-component failed was typically not reported, it is difficult to determine exactly why the rise has occurred with some older controllers.

Figure 4.32 gives the failure causes for controllers. With the exception of the four reported B&W failures, approximately 80% of the failures were potentially due to electrical or mechanical aging. Mechanical binding and wear were the most frequent reported mechanical causes, and defective circuitry accounted for most of electrical causes. Non-aging causes were reported in less than 20% of the instances,

Parameter Controlled

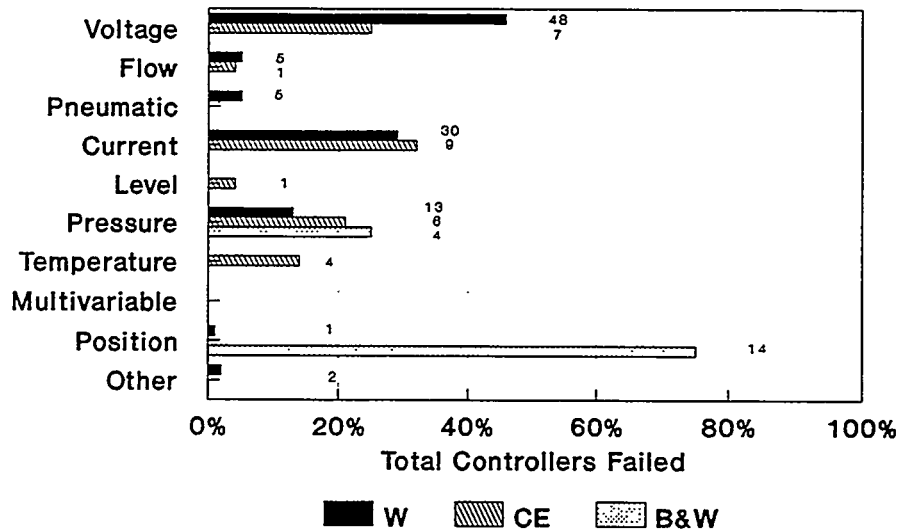

Figure 4.29 CVCS controller failures vs. inputs measured (NPRDS)

Failure Mode

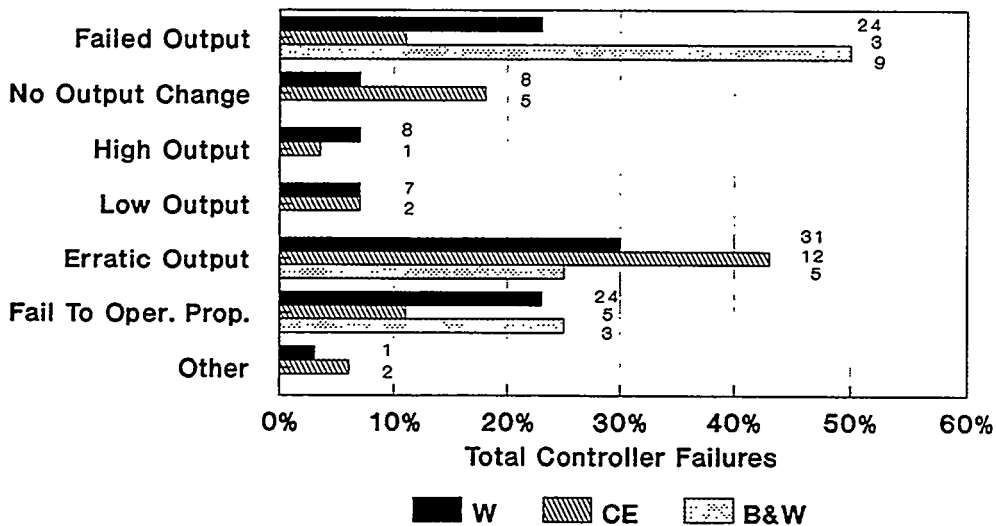

Figure 4.30 Controller failure modes (NPRDS)

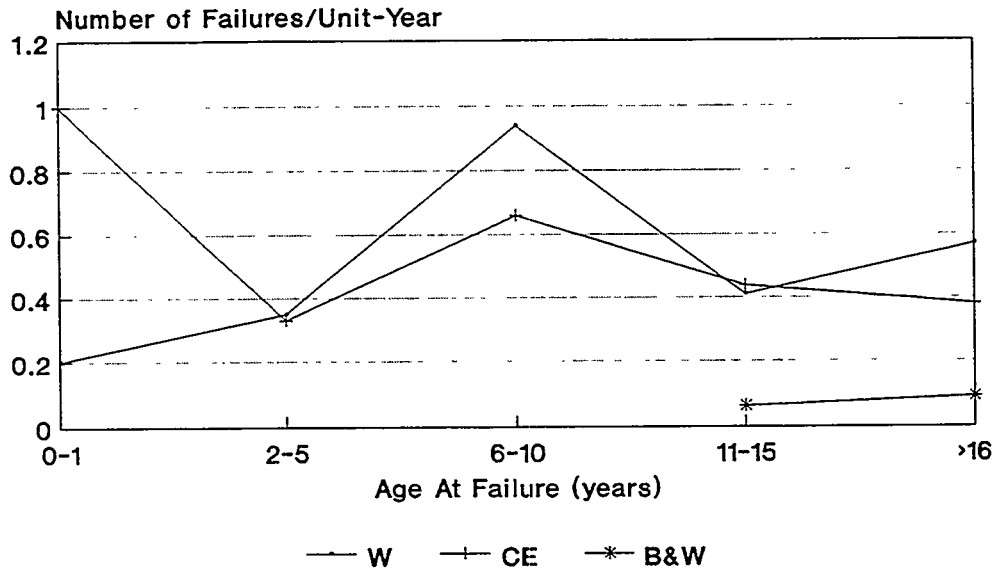

Figure 4.31 Controller age at failure (NPRDS)

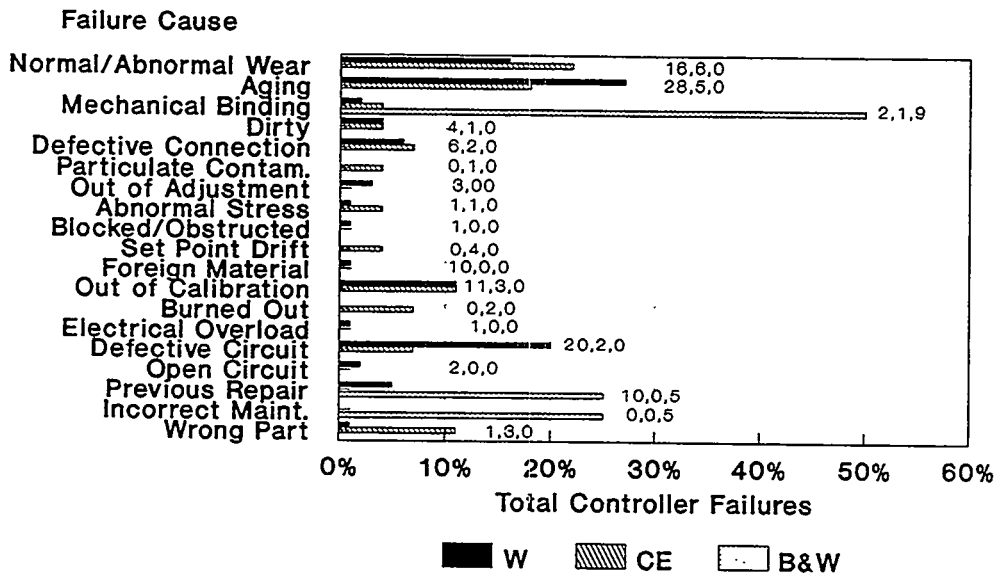

Figure 4.32 Controller failure causes (NPRDS)

with the installation of the incorrect part being the most common cause.

4.3 CVCS LERs

In addition to the system information obtained from reviewing the NPRDS data, LERs also provide important data on events which occurred during plant operation. Often, system and component failures which occur as a result of, or during, plant operation are not reported to the NPRDS database; therefore, it was important to evaluate both databases. In order to ensure that the information obtained from both databases correlated, the same period of review (1988-1991) was chosen.

As discussed (Figure 4.1), 2151 LERs have been written documenting CVCS system failures, degradations, and operational problems at PWR plants from 1980-1991. These LERs encompassed all of the failures associated with the CVCS system, including those not aging-related. Based upon a review of each LER, and contrary to that seen from the NPRDS review, it was found that the majority were not aging related and did not document component or system failures. These LERs typically reported missed or exceeded surveillance and inspection intervals, components inadvertently excluded from inspection programs, design problems, system actuation in response to other system failures, or human errors resulting in improper maintenance, improper installation, or improper lineup of system valves.

The remaining LERs, which documented either aging-related, or potentially aging-related failures, showed that each of the major system components failed during the period. The most frequently affected components were pumps and valves (Figure 4.3); this was anticipated, since the system is comprised mostly of valves (isolation, control, bypass, and check valves), and redundant pumps (charging and boric acid transfer). Failures of system piping were also reported in 10% of the LERs. Other component failures included boric acid heat tracing,

instrumentation (switches and level sensors), electrical components (relays, circuit breakers, and inverters), and single volume control tank and demineralizer failures.

As described in Section 2, the CVCS system is designed with significant primary component redundancy and alternate flowpaths, which allows for ease of maintenance while not affecting system operation, and minimizes the effect of individual component failures on system availability. A main effect of these failures which was not included in the LERs is loss of redundancy. As described in Section 8, this redundancy was the primary reason why system failures do not have a large effect on core damage frequency and PRA analyses. However, plant operators must remain cognizant of individual component failures since a loss of redundancy could have a significant impact if the standby component also fails. Degradation and failures of the charging and boric acid pumps were typical examples.

A significant plant effect was primary coolant leakage. Any CVCS component failure (outside of containment) or degradation which caused external leakage represents a release of coolant outside of containment, and if uncorrected could represent a small break LOCA. Examples included failures of charging pumps (seal failures), valves (degraded packing) and piping (wall cracks) failures. Many of the reported leaks inside containment were greater than the one gallon per minute leak allowed by individual plant Technical Specifications. These resulted in plant shutdowns, or removal of one train from service while repairs were made. Several LERs documented excessive personnel exposure from these leaks. Other isolated failures resulted in pressurizer level changes due to failures affecting letdown and charging flows.

4.3.1 Valve Failures

Valve degradation and failures accounted for the majority of LERs generated. In PWRs, the CVCS utilizes numerous valves of different sizes

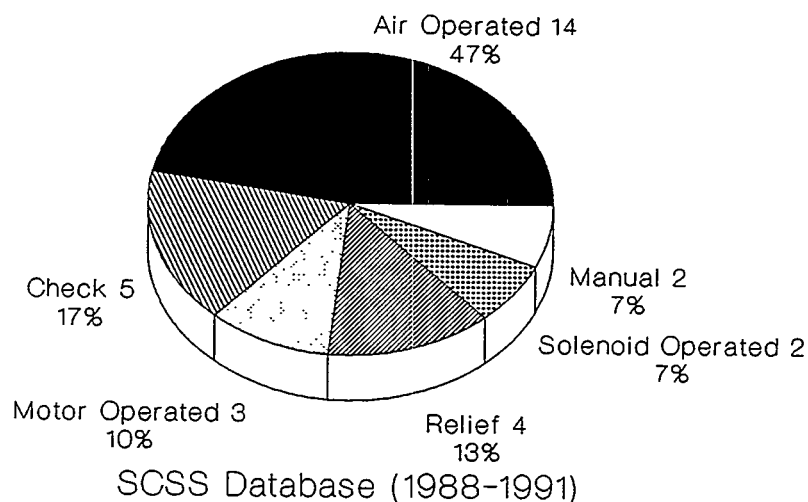

Figure 4.33 Valve failures vs. valve type (SCSS)

and operator types for the various system functions (Section 2 and Appendices A-C). Of the 30 LERs documenting valve failures, air-operated valves accounted for the majority of these, followed by check, motor-operated and relief valves (Figure 4.33). Two failures were also reported for solenoid operated and manual valves.

The specific causes for these failures is shown in Figure 4.34. Of the reported failure causes, none was dominant. Three valves were unable to operate due to the buildup and drying of a on-the-shaft lubricant. Several other failures were due to packing degradation and aging. Typically, packing failures are representative of a maintenance and aging problem. The root failure cause for these failures was listed as age related degradation. Normally, valve packing wear does not result in an operational problem. Each occurrence resulted in primary coolant leakage. In addition to the radiation and maintenance problems associated with such leakages, the boric acid in the coolant is highly corrosive and could affect the operability of other equipment in the vicinity

of the leak. Other failure causes were housing cracks, torn diaphragms, relief valve setpoint drift, and isolated occurrences of internal wear and binding. A significant number of failures did not have information on specific failure causes. It was unclear from the narratives contained in the LERs whether a root cause failure analysis was performed. Plant operators should ensure that reasonable efforts are made to identify failure causes to prevent them from recurring or affecting other valves.

The effect of these failures depended upon the valve type, failure cause, and valve function (Figure 4.35). In many instances, several failure effects were attributable to one failure cause; for example, several check valves failed open due to mechanical wear of the internals. These occurrences resulted in internal leakage as well as a valve which failed in the open position. Degradation of packing, valve housing cracks, and relief valves which failed in the open position all resulted in external leakages. Though not shown as a specific effect, the majority of failures also represented a loss of redundancy. Containment isolation valves which

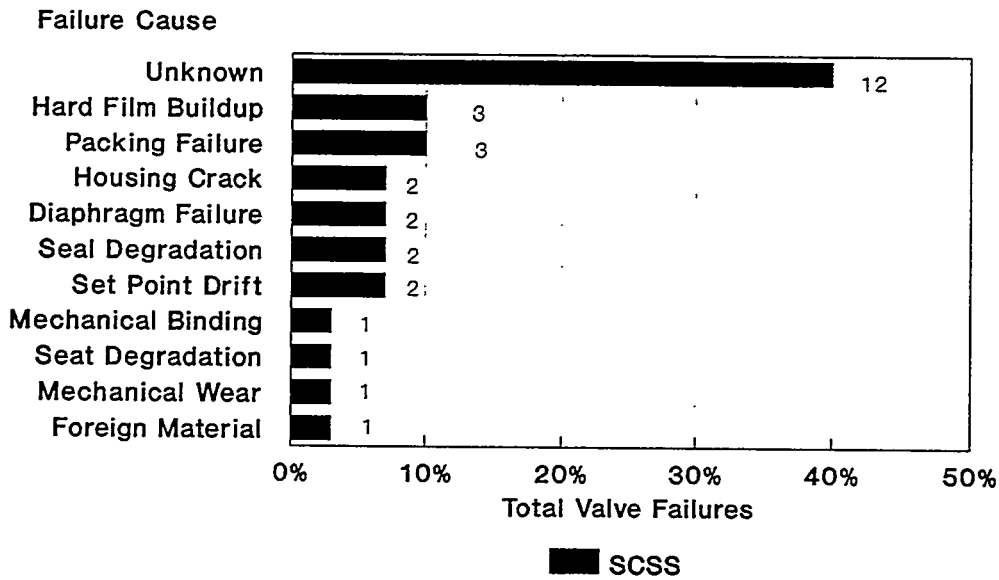

Figure 4.34 Valve failures vs. failure cause (SCSS)

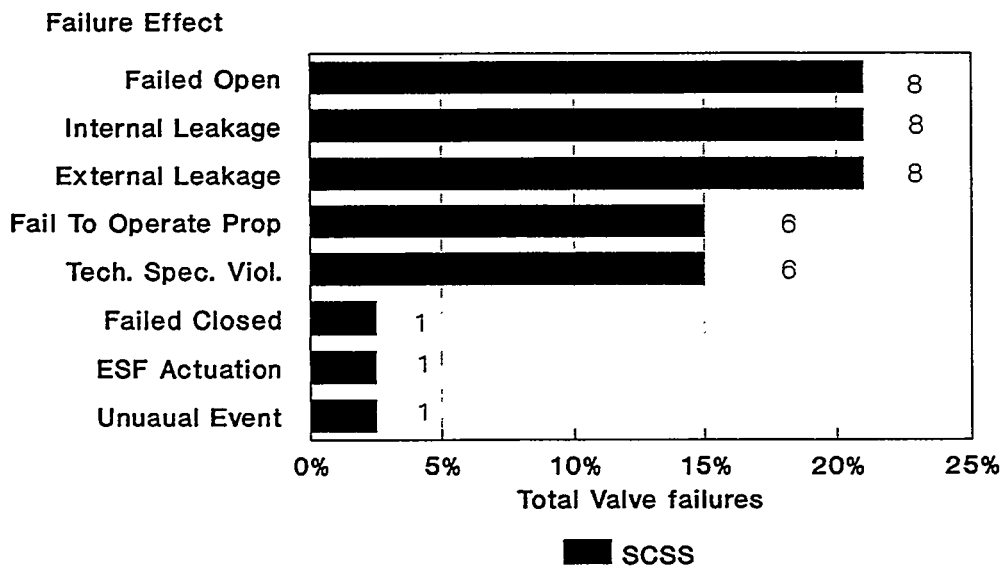

Figure 4.35 Valve failures vs. failure effect (SCSS)

failed open also resulted in Technical Specification violations by not meeting the leak requirements as specified in 10CFR50 Appendix J.

One instance of emergency safety system actuation in response to a failed open relief valve was reported. The root failure cause for this was not reported. In another instance, failure to close of a manual drain valve resulted in a large leakage of primary coolant. This resulted in the licensee declaring an unusual event until the leak was identified. Again, no cause was given, but most probably was due to human error.

4.3.2 Pump Failures

As shown in Figure 4.36, of the 19 pump failures reported, charging pump failures accounted for the majority (84%). Only three instances of boric acid transfer pump degradation were reported (16%). Charging pump failures are particularly significant because in addition to providing the charging flow, they also provide high pressure injection in most PWR plants. All of the failures reported occurred during normal charging operation and not during high pressure safety injection.

Figure 4.37 lists the reported causes for these pump failures. Seal degradation, and mechanical wear of the pump internals were the leading failure causes. The three failures of the boric acid transfer pumps were attributed to seal failure. Isolated instances of lube-oil failures, bearing and shaft failures were also reported. The effects of these failures are shown in Figure 4.38. The primary effect of these failures was having the pump declared inoperable by the licensee and removed from service. Similar to valve failures, one of the main effects of all the pump failures was a loss of redundancy. Typically, pump failures did not violate plant Technical Specifications. Numerous other examples were reported, due to human error, when two pumps were removed from service inadvertently in violation of the Technical Specifications.

4.3.3 Piping Failures

Though piping failures were not frequently reported during the period, they also represent a potential for primary coolant leaks. The six failures were due to fatigue, vibration, and weld failure (33% each) (Figure 4.39). All of the system piping is fabricated from austenitic stainless steel due to the corrosive properties of the reactor coolant and the chemicals added to it. As shown on Figure 4.40, each resulted in primary coolant leakage, with resultant Technical Specification violations, unit shutdown or power reduction in response to the leakages (2 instances each). Two of the piping failures occurred at the charging pump suction, and were attributed to excessive pump vibration. The two cracked welds were caused by high vibration, and the other by excessive misalignment.

4.4 Miscellaneous Failures

With the exception of the pump, valve, and piping failures previously discussed, no other system component accounted for any significant number of failures. A single volume control tank failure resulting in coolant leakage was reported. This failure must be considered potentially due to aging, because no root failure cause was provided by the licensee. It is unclear as to whether this failure was in fact aging-related, since all the volume control tanks are fabricated from austenitic stainless steel. Depleted resin was the root cause of the one demineralizer failure. This occurrence resulted in excessive chloride level in the reactor coolant, resulting in a Technical Specification violation. Four occurrences of heat trace failures were reported on the boric acid piping, which were due to degradation in the power supply to the heat trace; all resulted in one of the redundant boric acid paths being removed from service. Undetected, these failures could result in boric acid precipitates blocking the coolant flow paths. Sensor failure due to connection degradation resulted in two instances of incorrect VCT and RWST level indications.

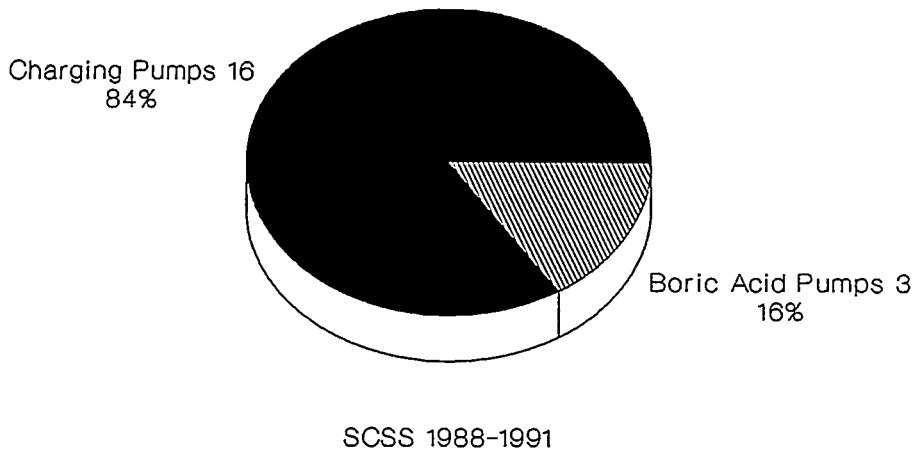

Figure 4.36 Pump failure vs. pump function (SCSS)

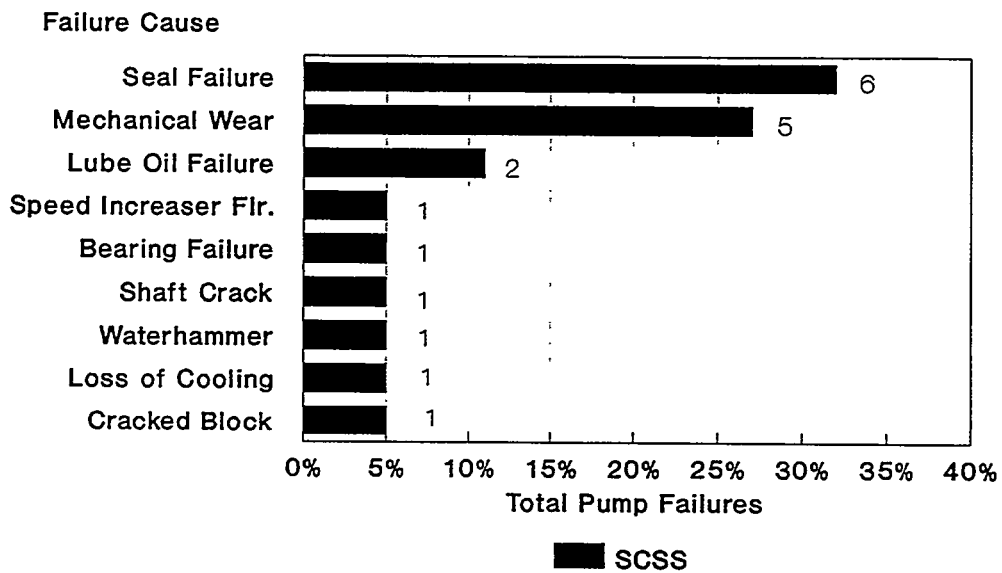

Figure 4.37 Pump failures vs. failure cause (SCSS)

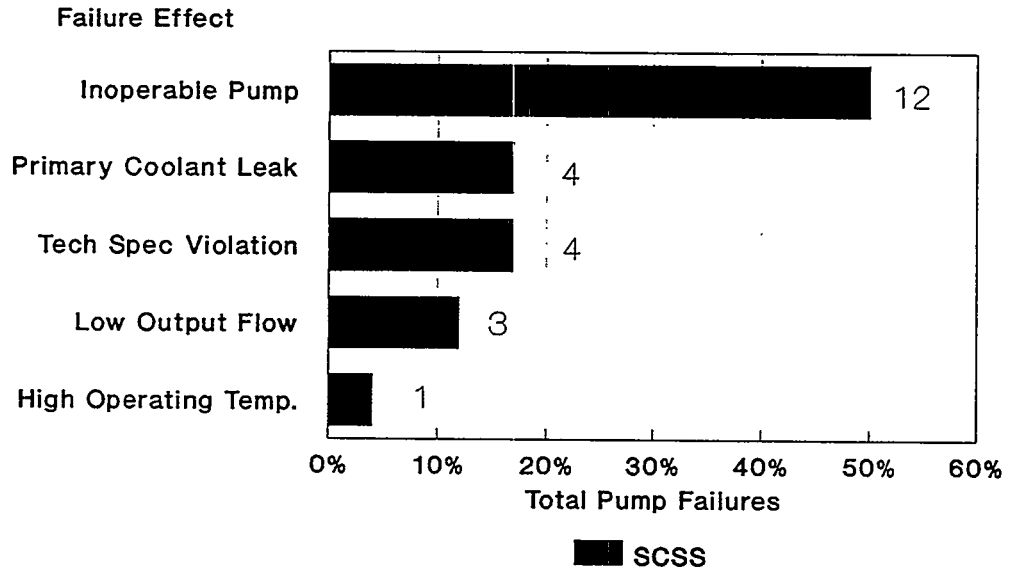

Figure 4.38 Pump failure vs. failure effect (SCSS)

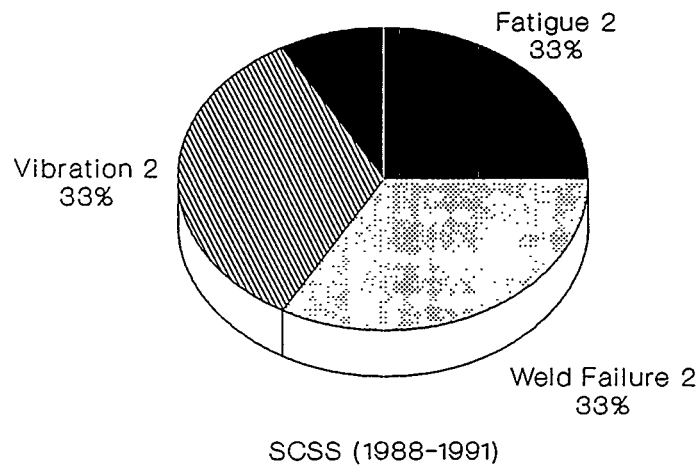

Figure 4.39 Piping failure causes (SCSS)

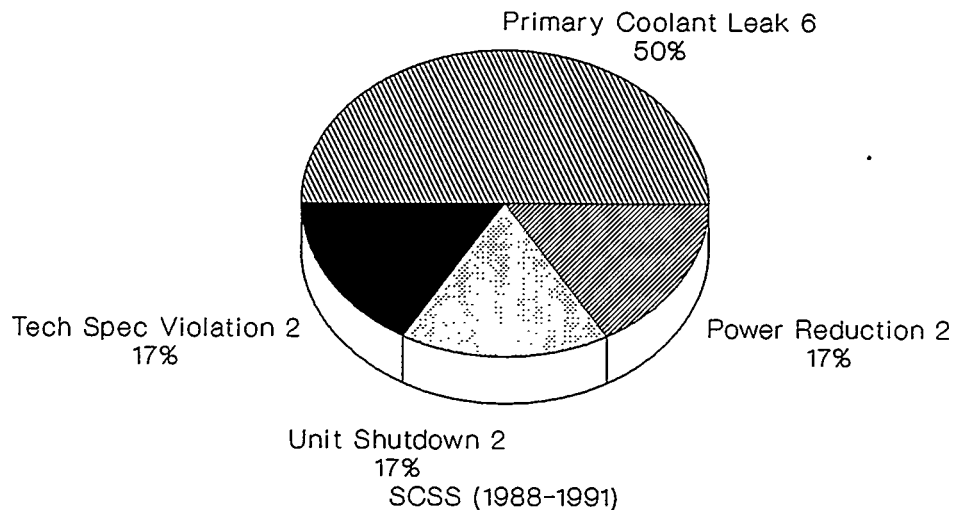

Figure 4.40 Piping failures vs. failure effect

4.5 Summary

The review of operating data for the 1988 to 1991 period indicates that the CVCS components have experienced notable age degradation and failure. Greater than 50% of the events reported to the NPRDS and SCSS databases were classified as aging or potentially aging related.

The most frequently affected components were valves, pumps, and valve operators. Due primarily to the redundancy designed into the system, failure of these components did not typically result in significant plant effects. However, these occurrences did represent a loss of redundancy, which in the event of the failure of the backup component, loss of system function could result. While not occurring frequently, system failures have resulted in reactivity transients and pressurizer level changes.

The most common effect of both pump and valve failures was reactor coolant leakage. This is significant for components located outside of

containment. In addition, as specified in plant Technical Specifications, unidentified leakages greater than 1 gpm on containment may require either a power reduction or plant shutdown to repair the leak. Another significant effect is a increase in airborne gaseous activity resulting from degradation of pump packing.

Though both centrifugal and positive displacement pumps are used in the CVCS, most of the reported failures were for the latter. When operating, these pumps produce significant vibratory stresses which have resulted in both pump and piping failures. Aging degradation of the packing and seals due to wear was commonly reported. These instances are a result of normal pump operation and resulted in external leakage, and failure to run properly. Since the positive displacement pumps are not typically used to provide high pressure injection, the ability of the system to mitigate the consequences of a potential accident were not affected. However, they did affect the ability of the system to provide charging flow.

5. EFFECT OF COMPONENT FAILURES ON CVCS SYSTEM

As discussed in Section 2., the primary functions of the CVCS are letdown, purification, boration and chemical addition, boron regeneration, charging, RCP seal injection and safety injection. The system consists of the mechanical components (pumps, valves, heat exchangers, volume control tanks, and deionizers), instrumentation, and controls, necessary to perform these functions.

A Failure Modes and Effects Analysis (FMEA) was performed for each PWR design to determine the effects of failures of the major system components. Each FMEA included the following items:

- a) Failure Mode: The basic manner(s) which a component may fail or cease to perform as designed. The failure modes for these components were consistent with those used in industry reliability standards.
- b) Failure Cause: The particular type of degradation mechanisms which may cause the component to failure. These stressors were discussed in Section 3.
- c) Failure Effect: The effect on the CVCS system due to the component failure.
- d) Detection Methods: Functional indicators or system and plant operating characteristics which would alert the operator of component degradation and/or failure.

An important system function in many PWR plants is to provide High Pressure Injection under certain accident conditions. Since this function was previously evaluated (Ref. 3), it was not included in these FMEAs. However, it is important to recognize that many of the CVCS components that provide reactor charging are also used for High Pressure Injection. Aging degradation and failures of these components

which result from normal plant operation, will also affect their ability to provide high pressure injection. It is essential that system aging be understood, and detected, before it results in the inability of the system to perform its safety related function.

5.1 Westinghouse, Babcock & Wilcox, and Combustion Engineering CVCS FMEAs

All PWR plants use the CVCS to provide for letdown, purification, boration, chemical addition, RCP seal injection and charging functions. Tables 5.1 to 5.3 show the FMEAs for the Westinghouse, Babcock & Wilcox, and Combustion Engineering CVCS designs respectively.

Each CVCS design has sufficient redundancy, and alternate flowpaths, such that single component failures will not render the system incapable of functioning. Through manual or automatic actions, alternate flowpaths can be established, and standby components activated, so that individual component failures will not adversely affect system operation. For example, the CVCS system contains redundant letdown and charging valves, deionizers, and charging pumps. However, failure of these components would represent a loss of redundancy, which in the event of other failures, may render the system inoperable.

Typically, component degradation and failure will only affect a particular system function, and not the total system or other functions. For example, a failed deionizer, caused by spent or degraded resin, will impair only the ability of the system to adequately purify the coolant, but will not affect letdown and charging flow control. However, if not detected and repaired in a timely manner, the degraded operation of the deionizers may affect the operation of other system components due to the inability to remove the reactor coolant impurities.

Certain system components are required to provide multiple functions, and their failure and degradation will affect each function. The regenerative heat exchanger (W and CE) is used for the letdown flow temperature reduction, and also to reheat the charging flow prior to injection back into the RCS. Failure of the heat exchanger due to inadequate heat transfer, or blocked flow paths (due to the buildup of corrosion products) may result in out-of-specification coolant temperatures. High letdown temperature will prematurely degrade the deionizer resins, while a low charging flow temperature may cause thermal shock to the injection nozzles. A failure of one charging pump represents a loss of redundancy which will not normally impact the system's performance. However, if more than one pump fails, the system would be unable to provide both adequate charging flow, and reactor coolant pump seal flow. Charging pump failures will also impact the safety related, high pressure injection as well.

With the exception of system failures which affect the ability to perform safety related functions, CVCS failures do not compromise plant safety. However, they challenge plant operation, which may result in plant shutdown. Under normal operating conditions, the CVCS assists in controlling pressurizer level by adjusting both the letdown and charging flow. Failures which result in the loss of these functions, or flow rate changes, may result in pressurizer level and primary system pressure perturbations. These occurrences may cause the activation of other systems, such as the pressurizer heaters or spray, to correct the system's pressure. Such unnecessary actuations represent challenges to the operation of these systems, and may contribute to their aging degradation.

Operational effects may also result from failure of the boration and purification portions of the system. Reactivity control is accomplished by both the CVCS and the control

rod assemblies. The control rods compensate for short term reactivity effects, while the CVCS compensates for long-term reactivity effects due to coolant temperature changes, xenon concentration, and fuel burnup by controlling the amount of soluble boron in the RCS. Component failures affecting the boration and purification functions would result in an imbalance of soluble boron, and reactivity transients. Failures of the boric acid tank immersion heaters, and heat tracing are typical examples of failures which could prevent proper boration. Degradation of ion exchanger resins would result in the inability to remove boron from the RCS and may cause an over-boration condition, and reactor coolant chemistry control perturbations.

A similar operational effect would result from the failure of the boron thermal regeneration portion of the CVCS in the newer generation Westinghouse plants. Table 5.4 presents the FMEA for this portion of the system. Failures of the chillers and the boration demineralizers could result in either the dilution, or over boration of the RCS. Since this is normally an automatic function, any unanticipated boron concentration transients would also result in reactivity transients.

Another important effect of CVCS component failures is external leakage. Any primary coolant leakage from components located outside of containment represents both a radiological and an operating hazard. The uncontrolled release of primary coolant inside containment would present a radiological hazard to the plant staff. If this leakage came in contact with other components, degradation and failure may result due to the highly corrosive characteristics of the boric acid contained in the coolant. Unidentified leakages in-excess of the one gallon per minute Technical Specification limit would require the plant operator to isolate the system and correct the leak. Undetected and uncorrected, these may also represent a small break LOCA.

Table 5.1 Westinghouse CVCS FMEA²²
(Letdown, Boron Storage, RCP Seal Cooling and Charging)

Table 5.1 Westinghouse CVCS FMEA
(Letdown, Boron Storage, Seal Cooling and Charging)

Component	Failure Mode	Failure Causes	Failure Effect	Failure Detection Methods	Notes
Letdown Flow Control Valves	a. Fails Open	Mechanical binding.	Loss of redundancy. Unable to terminate letdown flow.	Remote valve position indication. Downstream flow and temperature indicators.	Valves are designed to fail closed upon loss of power (or air supply).
	b. Fails Closed	Loss of air or electrical power. Spurious signal.	Loss of redundancy. Loss of normal letdown flow path thru regenerative heat exchanger.	Remote valve position indication. Letdown flow and pressure indicators.	
Regenerative Heat Exchanger	a. Plugged Tubes	Corrosion product buildup. Boron buildup. Foreign material in RCS.	Reduced letdown flow.	Flow indicator.	Total tube plugging unlikely. Flow deterioration should be detected before complete plugging occurs.
	b. Insufficient heat transfer	Scale buildup on tubes.	Temperature of letdown flow may exceed design limits, resulting in possible damage to downstream components.	Regenerative heat exchanger outlet temperature indicators.	
	c. External leakage	Casing crack. Vent valve seat leakage.	Reduced letdown flow. Primary coolant release.	Excessive makeup flow rate. Containment radiation monitors.	
	d. Tube leakage	Corrosion. Manufacturing defect.	No effect.	Pressure differential across heat exchanger. Temperature indications.	

Table 5.1 (Cont'd)

Component	Failure Mode	Failure Causes	Failure Effect	Failure Detection Methods	Notes
Orifice Isolation Valves	a. Fails Open	Mechanical binding.	Loss of redundancy. Loss of normal letdown flow path.	Remote valve position indicator. Letdown flow and pressure indicators.	Valves designed to fail closed upon loss of power (or air supply)
	b. Fails Closed	Loss of air or electrical power. Spurious signal.	Blockage of flow to VCT.	Remote valve position indicator. Letdown flow and pressure indicators.	
Containment Isolation Valve	a. Fails Open	Mechanical binding.	Loss of redundancy. Degraded containment isolation.	Remote valve position indicator. Appendix J leak testing.	
	b. Fails Closed	Loss of air or electrical power. Spurious signal.	Loss of redundancy. Loss of normal letdown flowpath.	Remote valve position indication. Letdown flow and pressure indicators.	
Letdown line relief valve	a. Fails Open	Setpoint drift. Mechanical failure.	Primary coolant discharged to pressurizer relief tank.	Excessive use of makeup water. Downstream low flow and pressure indications.	
	b. Fails Closed	Setpoint drift. Mechanical failure.	Loss of overpressure protection.	ASME Section XI testing.	

Table 5.1 (Cont'd)

Component	Failure Mode	Failure Causes	Failure Effect	Failure Detection Methods	Notes
Non-regenerative heat exchanger	a. Plugged tubes	Corrosion product buildup. Boron buildup. Foreign material in RCS.	Reduced letdown flow.	Downstream flow and pressure indicators.	
	b. Insufficient Heat Transfer	Scale buildup on tube.	High exit temperature may exceed design limits, resulting in downstream component damage.	Heat exchanger outlet flow temperature indicator.	
	c. Tube leak	Corrosion. Manufacturing defect.	Contamination of CCW cooling water.	CCW radiation monitor. Excess use of makeup water. CCW surge tank level increase. Low flow indication.	
	d. External leakage	Casing crack. Vent valve seat leakage.	Reduced letdown flow. Primary coolant release.	Excessive makeup flow rate.	

Table 5.1 (Cont'd)

Component	Failure Mode	Failure Causes	Failure Effect	Failure Detection Methods	Notes
Pressure Control Valve	a. Fails Open	Valve operator malfunction. Mechanical binding.	Loss of redundancy. Loss of pressure control to prevent steam flashing.	Pressure indication alarm (low pressure, high temperature)	
	b. Fails Closed	Loss of air or electrical power. Spurious signal.	Loss of redundancy. Loss of letdown flow. Possible RCS overpressurization.	Remote pressure and flow indicators. Remote valve position indicator.	
	c. Fails to open properly	Valve operator malfunction. Mechanical binding.	Pressure increase in non-regenerative heat exchanger. Reduced letdown flow. Opening of downstream relief valve. Possible RCS overpressurization.	Pressure indication alarm.	
3 Way Temperature Control Valve	a. Fails open for flow only to VCT.	Valve Operator malfunction. Mechanical failure.	Letdown prevented from flowing to demineralizers. Fission product buildup.	Remote valve position indicator.	
	b. Fails open for flow only to demineralizers	Valve operator malfunction. Mechanical failure.	Continuous letdown flow to demineralizers. Possible damage to demineralizers due to high RCS temperature.	Remote valve position indicator.	

Table 5.1 (Cont'd)

Component	Failure Mode	Failure Causes	Failure Effect	Failure Detection Methods	Notes
Demineralizers	a. Ineffective ion or boron removal	Degraded resin. Incorrect resin.	Primary coolant fission product and boron buildup.	Process radiation monitor. Process sampling.	
	b. Plugged	Particulate contamination.	Decreased letdown flow.	Demineralizer differential pressure increase.	
	c. External Leakage	Cracked vessel. Corrosion. Manufacturing defect.	Primary coolant release outside of containment	Local leak and radiation monitors.	
VCT Level Divert Valve	a. Fails Open to bypass position	Valve operator malfunction. Spurious signal.	Decrease in VCT level. Unplanned release of primary coolant to holdup tanks.	VCT level indicator. Remote valve position indication.	
	b. Fails open to VCT	Valve operator malfunction. Mechanical failure.	Unable to bypass VCT for additional coolant treatment	VCT level indicator. Remote valve position indication.	
Volume Control Tank	a. External Leakage	Corrosion. Manufacturing defect.	Release of primary coolant outside of containment.	VCT level indication.	
VCT Relief Valve	a. Fails Open	Setpoint drift. Mechanical failure.	VCT liquid vented to nuclear drain system. Loss of VCT contents. Degraded system operation.	VCT level decrease. Holdup tank level increase.	
	b. Fails Closed	Setpoint drift. Mechanical Failure.	Overpressurization of VCT.	VCT pressure indicator.	

Table 5.1 (Cont'd)

Component	Failure Mode	Failure Causes	Failure Effect	Failure Detection Methods	Notes
Chemical Addition Control Valve	a. Fails Open	Mechanical binding. Valve operator malfunction.	Overpressurization of VCT with Hydrogen or Nitrogen.	VCT pressure indicator.	
	b. Fails Closed	Loss of air supply. Spurious signal.	Loss of hydrogen and Nitrogen flow to VCT resulting in RCS fission product increase.	VCT pressure indicator and low pressure alarm.	
VCT Degassifier Valve	a. Fails Open	Mechanical binding. Valve operator malfunction.	Loss of overpressurization of VCT.	VCT pressure indicator.	
	b. Fails Closed	Loss of air supply. Spurious signal.	Loss of venting VCT gas mixture to boron recycle degassifier.	VCT pressure indicator and remote high pressure alarm.	
VCT volume Control Valve	a. Fails Open	Mechanical binding. Valve operator malfunction.	High primary makeup flow to VCT. Possible RCS deboration.	Low boron concentration. High flow and VCT level indicators.	
	b. Fails Closed	Shaft binding. Valve operator malfunction.	Low primary makeup flow rate to VCT. Possible overboration of RCS.	High boron concentration. Low flow indication to VCT.	
Boric Acid Tanks	a. External Leakage	Corrosion. Manufacturing defect.	Loss of all, or partial, volume of tanks. Loss of boric acid supply to VCT and RCS.	Tank level monitors.	

Table 5.1 (Cont'd)

Component	Failure Mode	Failure Causes	Failure Effect	Failure Detection Methods	Notes					
Boric Acid Transfer Pump	a. Fails to Operate	Shaft shear. Shaft seizure. Motor failure. Electrical failure. Loss of head.	Loss of boron addition capability. Loss of redundancy. Boric Acid crystallization. Failure of Boric Acid Tank heaters.	Low flow and pressure alarms from pump. Boric Acid Tank level indicators.						
						b. Spurious Start	Spurious electrical signal.	Possible excessive boron addition.	Pump discharge pressure and flow indicators.	
Chemical Mixing Tank	a. External Leak	Corrosion. Manufacturing defect.	Chemical solution spill. Reduced chemical addition capability.	RCS chemical sampling. Tank level indicators.	Not a storage tank. Chemical solution made and added to RCS as needed.					
Boric Acid Blender Flow Control Valve	a. Fails Open	Mechanical binding. Valve operator failure.	Unable to provide required water makeup volume required for normal plant operation.	Valve position indication. Makeup water flow indicator.						
	b. Fails Closed	Loss of air supply. Spurious signal.	Unable to provide water makeup required for normal plant operation.	Valve position indication. Makeup water flow indicator.						

Table 5.1 (Cont'd)

Component	Failure Mode	Failure Causes	Failure Effect	Failure Detection Methods	Notes
Boric Acid Blender Outlet Flow Control Valve	a. Fails Open	Mechanical Binding. Valve operator failure.	Unable to provide required concentration of boric acid to RCS when attaining a hot shutdown.	Valve position indicator. Boric acid flow recorder.	
	b. Fails Closed	Loss of air supply. Spurious signal.	Unable to provide concentrated boric acid solution during hot shutdown.	Valve position indicator. Boric acid flow recorder.	
VCT Outlet Control Valve	a. Fails Open	Mechanical binding. Valve operator failure.	Gas binding of charging pumps. Hydrogen injection into RCS.	Valve position indicator.	
	b. Fails Closed	Loss of power. Spurious signal.	Loss of fluid flow from VCT to charging pumps.	Valve position indicator. VCT level indicator.	
Emergency Boration Valves	a. Fails Open	Mechanical binding.	Unable to isolate flow from boric acid transfer pumps. Over-boration of RCS.	Valve position indicator. Boric acid tank level indicator.	
	b. Fails Closed	Shaft binding. Valve operator malfunction.	Unable to provide emergency boration.	Valve position indicator. Boric acid tank level indicator.	

Table 5.1 (Cont'd)

Component	Failure Mode	Failure Causes	Failure Effect	Failure Defection Methods	Notes
Charging Pumps (Centrifugal and positive displacement pumps)	a. Failure to operate continuously	Shaft shear. Shaft seizure. Motor failure. Loss of power. Loss of suction head.	Loss of redundancy. Unable to provide charging flow under normal operating conditions (3 pumps fail).	Pump outlet flow and pressure instrumentation. Circuit breaker monitoring light.	Only normal operation of charging pumps is considered. High pressure injection not included in this study.
	b. Degraded Operation	Boron crystallization. Degraded suction.	Loss of redundancy. Unable to provide proper charging flow in response to operations. Loss of RCP seal water of cooling.	Pump outlet flow and pressure instrumentation.	
	c. Spurious Start	Spurious electrical signal.	Possible excessive RCS charging flow.	Pump outlet flow and pressure instrumentation. Circuit breaker monitoring lights.	
Charging Pumps Outlet Check Valves	a. Fails to open	Broken internals. Fatigue. Vibration.	Loss of redundancy. Failure to provide desired output charging flow and RCP seal cooling flow.	Charging pump output flow and pressure indication.	
	b. Fails to open fully	Broken internals. RCS debris.	Loss of redundancy. Failure to provide full flow for charging and RCS seal cooling.	Charging pump output flow and pressure indicator.	
	c. Fails to close	Broken internals. Fatigue. Vibration. RCS debris.	Backflow to pump. Unable to provide design flow.	Pump operating in reverse.	

Table 5.1 (Cont'd)

Component	Failure Mode	Failure Causes	Failure Effect	Failure Detection Methods	Notes
Charging Pump Flow Control Valve	a. Fails open	Mechanical Binding.	Unable to automatically adjust charging flow through control of pressurizer water level, charging flow, and RCP seal flow.	Charging water flow indicator.	
	b. Fails closed	Loss of air or electrical power. Spurious signal.	Unable to automatically adjust charging flow through control of pressurizer water level, charging flow, and RCP seal flow. Normal boration flow path unavailable.	Low charging flow indication.	
Charging Flow Isolation Valve	a. Fails open	Mechanical Binding.	Loss of redundancy in providing isolation of charging line during accident conditions.	Remote valve position indication.	Valve normally full open. Motor operator energized upon generation of safety injection signal.
	b. Fails closed	Loss of electrical power. Spurious signal.	Loss of normal charging flow path flow boration, dilution and coolant makeup. Loss of cooling flow to regenerative heat exchanger.	Remote valve position indicator. Letdown temperature flow indicator. Charging water flow and temperature indication VCT level indication.	
RCP seal water flow control valve.	a. Fails Open	Mechanical binding. Loss of air or electrical power.	Unable to provide manual adjustment of RCP seal water flow.	RCP seal water flow pressure indication.	Valve designed to fail open on loss of air or electrical power to ensure flow to number 1 RCP seals.
	b. Fails Closed.	Spurious signal.	Unable to provide manual adjustment of RCP seal water flow.	RCP seal water flow pressure indication.	

Table 5.1 (Cont'd)

Component	Failure Mode	Failure Causes	Failure Effect	Failure Detection Methods	Notes
RCP seal water motor operated valve	a. Fails Open	Mechanical Binding. Loss of air or electrical power.	No effect other than to isolate seal water flow.	RCP seal water flow pressure indication.	
	b. Fails Closed.	Spurious signal.	Loss of seal water to RCP seals. RCP damage. Primary coolant leakage.	RCP seal water flow and pressure indication. RCP external leakage.	
RCP Seals Stand Pipe Globe Valve	a. Fails Open	Mechanical binding.	None.	Valve position indication. Standpipe level indicator.	Standpipe alarm set to allow additional RCP operation before complete loss of seal water flow.
	b. Fails Closed	Loss of power. Spurious signal.	Loss of makeup of seal water to standpipe which services the No. 3 RCP seal.	Valve position indication standpipe level indication.	
Seal Water Return Header Relief Valve	a. Fails Open	Setpoint drift Mechanical failure.	RCP seal water return flow and excess letdown flow bypassed to pressurizer relief tank. Failure inhibits use of excess letdown fluid system as an alternate means of letdown flow controls.	Pressurizer relief tank level and pressure indication. VCT level indication.	
	b. Fails Closed	Setpoint drift. Mechanical failure.	Loss of seal water return header over pressure protection.	VCT level indication pressurizer relief tank level and pressure indication.	

Table 5.1 (Cont'd)

Component	Failure Mode	Failure Causes	Failure Effect	Failure Detection Methods	Notes
Seal Water Return Header Globe valve	a. Fails Open	Mechanical binding. Loss of electrical power.	Loss of redundancy of providing isolation of seal water and excess letdown flow.	Remote valve position indication.	Valve is normally open. MOV energized to close the valve upon receipt of ESF signal.
	b. Fails Closed.	Spurious signal.	Seal water return and excess letdown flow blocked. Degraded seal cooling capability.	Remote valve position indication. Seal water return flow indicator.	
Seal Water Heat Exchanger Relief Valve	a. Fails Open	Setpoint drift. Mechanical failure.	Portion of seal water return flow and charging pump min-flow bypassed to VCT.	High VCT temperature. High seal water heat exchanger temp.	
	b. Fails Closed.	Setpoint drift. Mechanical failure.	Loss of seal water heat exchanger overpressure protection.	Seal water heat exchanger pressure and flow indicator.	

Table 5.1 (Cont'd)

Component	Failure Mode	Failure Causes	Failure Effect	Failure Detection Methods	Notes
Seal Water Heat Exchanger	a. Plugged tubes	Corrosion product buildup. Boron precipitation. Foreign material in RCS.	Reduced seal water return flow.	Seal water heat exchanger flow, temperature, and pressure indicator.	
	b. Insufficient Heat Transfer.	Scale buildup on tubes.	High exit temperature may exceed VCT design temperature.	Seal water flow heat exchange flow, temperature, and pressure indicators.	
	c. Tube Leak	Corrosion. Manufacturing defect.	Contamination of CCW system. RCS dilution.	Seal water heat exchange flow and delta pressure indicators. CCW surge tank level indicator.	
	d. External leakage	Corrosion. Manufacturing defect.	No effect.	Pressure differential across heat exchanger. Temperature indicators.	
Excess Letdown Flow Control Valve.	a. Fails Open	Mechanical Binding.	Unable to isolate flow to either excess letdown heat exchanger or drain tank.	Remote valve position indicator. Excess letdown pressure and temperature indication.	
	b. Fails Closed.	Loss of power. Spurious signal.	Unable to use the excess letdown fluid system as an alternate means of controlling letdown flow, and pressurizer level control.	Valve position indicator. Excess letdown pressure and temperature indication.	

Table 5.1 (Cont'd)

Component	Failure Mode	Failure Causes	Failure Effect	Failure Detection Methods	Notes
Charging System Isolation Valves	a. Fails Open	Loss of electrical power. Mechanical Binding.	For normally open valves, no effect during regular operation. However, under accident conditions, failure results in signal to isolate charging line. For normally closed valves failure results in inadvertent operation of auxiliary spray resulting in reduced pressurizer pressure.	Valve position indicator. Charging flow indicator. Pressurizer pressure indication.	
	b. Fails Closed	Spurious signal.	For normally open valves, loss of normal charging flow path. For normally closed valves, loss of ability to provide auxiliary spray if required resulting in pressurizer over-pressurization.	Valve position indicator. Charging flow indicator. Pressurizer pressure indicator and level.	

Table 5.1 (Cont'd)

Component	Failure Mode	Failure Causes	Failure Effect	Failure Detection Methods	Notes
Excess Letdown Heat Exchanger	a. Plugged Tubes	Corrosion product buildup. Boron precipitation. Foreign material in RCS.	Reduced letdown flow.	Letdown flow, heat exchanger flow, temperature, and pressure indicators.	
	b. Insufficient Heat Transfer	Scale buildup on tubes.	High outlet temperature.	Letdown flow, heat exchanger flow, temperature, and pressure indicators.	
	c. Tube Leak	Corrosion. Manufacturing defect.	Contamination of CCW system. RCS dilution.	Letdown flow, heat exchange flow and delta pressure indicators.	
	d. External Leakage	Corrosion. Manufacturing defect.	No effect.	Pressure differential across heat exchanger, temperature indication.	

**Table 5.2 Babcock & Wilcox - Makeup and Purification System¹⁷
FMEA (Letdown, Boron Storage, RCP Seal Cooling and Charging)**

Table 5.2 Babcock & Wilcox - Makeup and Purification System
FMEA (Letdown, Boron Storage, Seal Cooling and Charging)

Component	Failure Mode	Failure Causes	Failure Effects	Failure Detection Methods	Notes
Letdown Cooler Isolation Valves	a. Fails Open	Mechanical binding.	Unable to isolate letdown flow from RCP suction. Loss of redundancy.	Valve position indication. Flow indication.	
	b. Fails Closed	Loss of electrical power. Spurious signal.	Loss of redundancy. Loss of letdown flow and purification makeup tank level decrease.	Valve position indication. Flow indication. Makeup tank level indication.	
Letdown Containment Isolation Valve	a. Fails Open	Mechanical binding.	Unable to isolate containment.	Remote valve position indication. Downstream flow indication.	
	b. Fails Closed	Loss of electrical power. Spurious signal.	Pressurizer level increase. Loss of letdown flow and purification makeup tank level decrease.	Makeup tank level indication. Valve position indication. Downstream flow indication.	

Table 5.2 (Cont'd)

Component	Failure Mode	Failure Causes	Failure Effects	Failure Detection Methods	Notes
Block Orifice Isolation Valve	a. Fails Open	Mechanical binding.	Excessive letdown flow.	High letdown flow. High filter pressure drop. Increasing makeup tank level. Increasing pressurizer level. Valve position indication.	
	b. Fails Closed	Loss of electrical power. Spurious signal.	Loss of RCS purification. Makeup tank level decreases	Low letdown flow. Low filter pressure drop. Decreasing makeup tank level. Decreasing pressurizer level. Valve position indication.	
Letdown Flow Control Valve	a. Fails Open	Mechanical binding. Spurious signal.	Letdown flow increase. Loss of redundancy.	Increased letdown and makeup flow rates. High filter pressure drop.	
	b. Fails Closed	Loss of air supply.	Letdown flow decrease. Loss of redundancy.	Decreased letdown and makeup flow rates. Low filter pressure drop.	

Table 5.2 (Cont'd)

Component	Failure Mode	Failure Causes	Failure Effects	Failure Detection Methods	Notes
Letdown Flow Relief Valve	a. Fails Open	Setpoint drift. Mechanical failure.	Letdown flow decrease. Increased flow to liquid radwaste system.	Decreased letdown flow and pressure indication. Valve position indication.	
	b. Fails Closed	Setpoint drift. Mechanical failure.	Loss of pressure relief capability in letdown header may result in overpressurization and component damage.	Increased letdown flow pressure. Remote valve position indication.	
Prefilter Bypass Valve	a. Fails Open	Spurious signal. Mechanical degradation.	Bypass of prefilter. Increased radiation buildup on demineralizers.	Decreased filter pressure drop. Valve position indication.	
	b. Fails Closed	Loss of air supply.	Inability to isolate prefilter for maintenance.	Valve position indication.	
Demineralizer Inlet Valves	a. Fails Open	Mechanical binding. Spurious signal. Loss of air supply.	No effect or letdown flow divides between standby demineralizers.	Valve position indication.	
	b. Fails Closed	Mechanical binding. Spurious signal.	Letdown flow causes and flow diverted to liquid waste storage system via relief valve. No effect for standby demineralizers.	Letdown flow and pressure indicator. Makeup and liquid waste storage tank level indication. Valve position indication.	

Table 5.2 (Cont'd)

Component	Failure Mode	Failure Causes	Failure Effects	Failure Detection Methods	Notes
Demineralizers	a. Ineffective ion removal	Degraded resin. Increased resin.	Primary coolant fission product buildup.	Process radiation monitor. Process chemical sampling.	
	b. Plugged	Particulate contamination.	Decreased letdown flow.	Demineralize pressure and flow indication.	
	c. External Leakage	Cracked vessel. Corrosion. Manufacturing defect.	Primary coolant release outside of containment.	Demineralizer pressure and flow indication. Local radiation monitors.	
Demineralize Outlet Valves	a. Fails Open	Mechanical binding. Foreign material.	No effect for operating demineralize letdown flow diverted to standby tanks.	Valve position indication. Demineralize level and flow indication	
	b. Fails Closed	Loss of air supply. Spurious signal.	Loss of letdown flow. Loss of RCS purification. Buildup of fission product contamination.	Letdown flow and pressure indication. Makeup and liquid waste storage tank level indication. Valve position indication.	
Trim Bleed Valve	a. Fails Open	Mechanical degradation. Spurious signal.	Letdown flow diverted to RC bleed holdup tank. Makeup tank level decrease.	Valve position indication. Makeup and RC bleed holdup tank level indicator.	
	b. Fails Closed	Loss of air supply. Flow Blockage.	Possible overpressurization of ion exchangers since flow to bleed tank preventor.	Valve position indicator. Makeup and RC bleed holdup tank level indicator.	

Table 5.2 (Cont'd)

Component	Failure Mode	Failure Causes	Failure Effects	Failure Detection Methods	Notes
Three Way Flow Control Valve	a. Fails Open	Spurious signal. Mechanical binding.	Letdown flow diverted to RC bleed tank, decreasing makeup tank level.	Valve position indicator. Makeup and RC bleed holdup tank level indication. Makeup flow indication.	
	b. Fails Closed	Loss of air supply.	Letdown flow blockage. Increasing system pressure diverted to liquid radioactive by opening of relief valve.	Valve position indication. Makeup tank level indication.	
Distillate Tank Flow Control Valves	a. Fails Open	Spurious signal. Mechanical binding.	Loss of redundancy. Possible overdilution of RCS makeup flow.	Valve position indication. Distillate and makeup tank level indication. RCS boron sampling.	
	b. Fails Closed	Loss of air supply. Spurious signal.	Possible overborator of RCS makeup flow by the inability to dilute with distillate flow.	Valve position indication. Distillate and makeup tank level indication RCS boron sampling.	

Table 5.2 (Cont'd)

Component	Failure Mode	Failure Causes	Failure Effects	Failure Detection Methods	Notes
Purification Filter Inlet Valves	a. Fails Open	Mechanical binding. Spurious signal.	No effect.	Pressure drop and flow through filters. Valve position indication.	
	b. Fails Closed	Spurious signal.	Loss of redundancy. If both valves fail closed, loss of makeup flow to makeup tank.	Valve position indication. Pressure drop and flow indication through filters. Makeup tank level indication.	
Makeup Tank Vent Valve	a. Fails Open	Spurious signal. Mechanical binding.	Unable to maintain hydrogen overpressure	Valve position indication. Low makeup tank pressure.	
	b. Fails Closed	Loss of power.	Unable to vent overpressure in makeup tank.	Valve position indication. Makeup tank pressure indication.	
Hydrogen Supply Valve	a. Fails Open	Spurious signal. Mechanical binding .	Potential overpressurization of makeup tank.	Valve position indication. Makeup tank pressure indication.	
	b. Fails Closed	Loss of air supply.	Unable to add hydrogen to makeup tank.	Valve position indication. Makeup tank pressure indication.	
Makeup Tank	a. External Leakage	Corrosion. Manufacturing defect.	Release of primary coolant outside of containment.	Makeup tank level indication.	

Table 5.2 (Cont'd)

Component	Failure Mode	Failure Causes	Failure Effects	Failure Detection Methods	Notes
Makeup Tank Outlet Valve	a. Fails Open	Spurious signal. Mechanical binding. Loss of power.	No effect	Valve position indication. Makeup tank level indication.	
	b. Fails Closed	Spurious signal. RCS contamination.	Loss of suction to makeup pumps. Low seal injection flow. Overboration of RCS due to flow from BWST.	Makeup pumps suction pressure indication. Increasing makeup tank level. Valve position indication.	
Makeup Pump	a. Failure to operate continuously	Shaft shear. Shaft Seizure. Motor Failure. Loss of power. Loss of suction.	Loss of redundancy. Unable to provide charging flow and seal injection flow (3 pumps fails).	Pump outlet flow and pressure indication. RCP seal temperature. Circuit breaker monitoring light. Makeup tank level indication.	
	b. Degraded Operation	Boron crystallization. Degraded suction flow.	Loss of redundancy. Unable to provide proper charging and seal injection flow.	Pump outlet flow and pressure indication. RCP seal temperature indication. Makeup tank level indication.	
	c. Spurious Start	Spurious electrical signal.	Possible excessive makeup flow.	Pump outlet flow and pressure instrumentation. Makeup tank level indication. Circuit breaker monitoring instrumentation.	

Table 5.2 (Cont'd)

Component	Failure Mode	Failure Causes	Failure Effects	Failure Detection Methods	Notes
Makeup Pump Recirculation Valve	a. Fails Open	Spurious signal. Mechanical binding.	Diversion of RCS flow to VCT.	Valve position indication.	
	b. Fails Closed	Loss of power.	Loss of pump recirculation flow.	Valve position indication. Recirculation line pressure indication.	
Seal injection flow control valve	a. Fails Open	Loss of air supply.	Not effect.	Valve position indication. Seal injection filter pressure drop and flow indication.	
	b. Fails Closed	Spurious signal.	Loss of redundancy. Boron concentration of RCS increases due to flow from BWST.	Valve position indication. Standby makeup pump operating status. Boron concentration in letdown flow.	
Borated Water Storage Tank Outlet Valve	a. Fails Open	Loss of electrical power.	No effect, since the makeup tank pressure is higher which maintains check valve closed.	Valve position indication.	
	b. Fails Closed	Spurious signal.	Loss of primary supply of emergency borated water.	Valve position indication. Boron precipitation BWST level indication.	

Table 5.2 (Cont'd)

Component	Failure Mode	Failure Causes	Failure Effects	Failure Detection Methods	Notes
Seal Injection Control Valve	a. Fails Open	Loss of electrical power.	No effect.	Valve position indication.	
	b. Fails Closed	Spurious signal.	Loss of redundancy. Loss of seal water injection flow to RCP. Boron concentrator in RCS increases.	Seal injection flow indication. Boron concentration in RCS. Borated water storage tank level indicator.	
Makeup Control Valves	a. Fails Open	Loss of air supply. Mechanical binding.	Loss of redundancy.	Valve position indication.	
	b. Fails Closed	Spurious signal.	Loss of redundancy. Potential loss of makeup flow.	Valve position indication. Makeup flow indication.	
Makeup Isolation Valves	a. Fails Open	Loss of power. Mechanical binding.	Unable to isolate makeup line.	Valve position indication. Makeup tank level indication. Pressurizer level indication.	
	b. Fails Closed	Spurious signal.	Loss of redundancy. Unable to provide normal makeup flow path.	Pressurizer and makeup tank level. Valve position indication.	
RCP Seal Water Return Valve	a. Fails Open	Mechanical binding. Spurious signal.	Unable to isolate seal water return flow if required.	Valve position indication. RC pump cavity pressure.	
	b. Fails Closed	Loss of electrical power.	Loss of seal return flow from one pump.	Valve position indication. RC pump cavity pressure.	

Table 5.2 (Cont'd)

Component	Failure Mode	Failure Causes	Failure Effects	Failure Detection Methods	Notes
Common RCP Seal Water Return Valve	a. Fails Open	Mechanical binding. Spurious signal.	No effect.	Valve position indication. Seal water return flow indication.	
	b. Fails Closed	Loss of power.	Loss of seal return from all RC pumps.	Valve position indication. RC pump cavity pressure.	
RC Bleed Holdup Tank Inlet Valve	a. Fails Open	Spurious signal. Mechanical binding.	Inability to stop bleed flow to bleed tanks.	Letdown pressure and flow indication. Valve position indication.	
	b. Fails Closed	Loss of power.	Bleed flow and letdown flow ceases, letdown relief valve opens. Power maneuvering is restricted.	High letdown pressure and low flow indication. Valve position indication.	
Boric Acid Pumps	a. Fails to operate	Shaft shear. Shaft seizure. Motor failure. Loss of electrical power. Loss of head.	Loss of redundancy. Boric acid crystallization. Failure of tank electric heaters. May result in control rod trip.	Low boric acid flow indication. Boric acid tank level indication. Circuit breaker monitoring lights.	
	b. Spurious Operation.	Spurious electrical signal.	Possible excessive boron addition.	High boric acid flow indication. Boric acid tank level indication. Circuit breaker monitoring lights.	
	c. Fails to produce design flow.	Boron crystallization. Failure of heat tracing.	Inadequate boron addition.	RCS boron level indication. Boric acid pump flow indication.	

Table 5.2 (Cont'd)

Component	Failure Mode	Failure Causes	Failure Effects	Failure Detection Methods	Notes
Emergency Boration Valves	a. Fails Open	Mechanical binding	Unable to isolate flow from boric acid transfer pumps. Over-boration of RCS.	Valve position indication. Boric acid tank level indicator.	
	b. Fails Closed	Shaft binding. Valve operator malfunction.	Unable to provide emergency boration.	Valve position indicator. Boric acid tank level indicator.	
Seal Water Return Coolers	a. Plugged tubes	Corrosion provided buildup. Foreign material in RCS.	Insufficient seal water and makeup pump recirculation cooling.	Seal water return cooler pressure flow and temperature indications. RCP seal temperature indication.	
	b. Tube leaks	Corrosion. Fabrication defect.	Reactor coolant inflow to CCW. Reduced seal water return flow to makeup tank.	CCW surge tank level indication. Makeup tank level indication. Seal water return cooler flow, and pressure indications.	
	c. External leaks	Corrosion. Fabrication defect.	Reduced seal water and makeup pump recirculation flow. Primary coolant leak.	Makeup tank level indication. CCW surge tank level indication. Local area radiation monitors.	
Concentrated Boric Acid Tanks	a. External leaks	Corrosion. Manufacturing defect.	Loss of concentrated boric acid solution.	Boric acid tank level indication.	

Table 5.2 (Cont'd)

Component	Failure Mode	Failure Causes	Failure Effects	Failure Detection Methods	Notes
Electric Heaters	a. Fail to operate	Loss of power.	Stratification of boric acid. Loss of flow to boric acid pumps.	RCS boron level indication. Concentrated boric acid tank concentration samples	
Letdown Cooler Heat Exchanger	a. Plugged Tubes	Corrosion product buildup. Boron buildup. Foreign material in RCS.	Reduced letdown flow.	Heat exchanger flow and pressure drop indications. Outlet temperature indication.	
	b. Tube leaks	Corrosion. Fabrication defect.	Reactor coolant inflow to CCW. Reduced letdown flow.	CCW surge tank level increase. Makeup tank level indication.	
	c. External leaks	Corrosion. Fabrication defect.	Reduced letdown flow. Primary coolant release.	Makeup tank level indication. Local area radiation monitors.	
	d. Insufficient heat transfer	Scale buildup on tubes	High exit temperature.	Temperature indicators.	

Table 5.2 (Cont'd)

Component	Failure Mode	Failure Causes	Failure Effects	Failure Detection Methods	Notes
Excess Letdown Heat Exchanger	a. Plugged Tubes	Corrosion product buildup. Boron precipitation. Foreign material in RCS.	Reduced letdown flow.	Letdown flow, heat exchanger flow, temperature, and pressure indicators.	
	b. Insufficient Heat Transfer	Scale buildup on tubes.	High outlet temperature.	Letdown flow, heat exchanger flow, temperature, and pressure indicators.	
	c. Tube Leak	Corrosion. Manufacturing defect.	Contamination of CCW system RCS dilution.	Letdown flow, heat exchange flow and delta pressure indicators.	
	d. External Leakage	Corrosion. Manufacturing defect.	No effect	Pressure differential across heat exchanger, temperature indication.	

Table 5.3 Combustion Engineering CVCS FMEA¹⁶

Table 5.3 Combustion Engineering CVCS FMEA

Component	Failure Mode	Failure Causes	Failure Effect	Failure Detection Methods	Notes
Letdown Stop Valve	a. Fails Open	Mechanical binding.	Loss of redundancy. Unable to terminate letdown flow. Potential damage to downstream system components.	Valve position indication. Letdown flow and temperature indication.	
	b. Fails Closed	Loss of air supply or power. Spurious signal.	Loss of letdown flow. Possible overcharging of RCS.	Letdown flow indication. Valve position indication.	
Regenerative Heat Exchanger	a. Plugged Tubes	Corrosion buildup. Boron buildup. Foreign material in RCS.	Reduced letdown flow.	Letdown flow indication. Regenerative heat exchanger pressure and flow indication.	
	b. Inadequate Heat Transfer	Scale buildup on tubes.	Insufficient cooling of letdown flow. Possible component damage.	Regenerative heat exchanger temperature indication.	
	c. External Leakage	Seat leakage on vent valve. Casing crack.	Letdown flow reduction. Primary coolant release inside containment.	Makeup flow indication. Containment radiation monitors.	
	d. Internal Leakage	Corrosion. Vibration induced wear. Fabrication defect.	Possible contaminant buildup in primary coolant. Reduced ability to alter boron concentration.	Boron level sampling indications. Heat exchanger flow indication.	

Table 5.3 (Cont'd)

Component	Failure Mode	Failure Causes	Failure Effect	Failure Detection Methods	Notes
Letdown Containment Isolation Valve	a. Fails Open	Mechanical binding.	Degraded containment isolation. Loss of redundancy. Possible inability to isolate letdown flow.	Valve position indication. Appendix J leak testing.	
	b. Fails Closed	Loss of air or power supply. Mechanical degradation. Spurious signal.	Loss of letdown flow. Possible overcharging of RCS.	Letdown flow and pressure indication. Valve position indication.	
	c. Regulates Low	Valve operator failure. Mechanical failure. Spurious signal.	Reduced letdown flow.	Low letdown flow and pressure indication. Pressurizer level indication.	
	d. Regulates High	Valve operator failure. Spurious signal.	Increased letdown flow.	High flow and pressure indication. Pressurizer level indication.	
Letdown Control Isolation Valves	a. Fails Open	Mechanical failure.	Loss of redundancy.	Valve position indication	
	b. Fails Closed	Mechanical failure.	Loss of redundancy.	Valve position indication	

Table 5.3 (Cont'd)

Component	Failure Mode	Failure Causes	Failure Effect	Failure Detection Methods	Notes
Letdown Line Relief Valves	a. Fails Closed	Mechanical failure. Setpoint drift.	Loss of overpressure protection for system.	Letdown pressure indication.	
	b. Fails Open	Setpoint drift. Mechanical failure.	Letdown flow discharged to holdup tanks.	Volume control tank level indication. Letdown flow and pressure indications.	
Letdown Heat Exchanger	a. Tube Leak	Corrosion, Manufacturing defect.	Contamination of CCW system with primary coolant	CCW surge tank level monitor. Makeup flow indication. CCW radiation monitors.	
	b. Tubes Plugged	Corrosion buildup. Boron buildup. Contaminant buildup.	Reduced letdown flow.	Letdown heat exchanger flow and pressure indication.	
	c. Insufficient Heat Transfer	Scale buildup. Inadequate CCW flow.	High temperature discharge, possible damage to downstream components.	Letdown heat exchanger temperature indications.	
	d. External Leakage	Corrosion, Manufacturing defect. Vent valve leakage.	Primary coolant leak outside of primary containment.	Local area radiation monitors. Letdown and makeup flow indicators.	

Table 5.3 (Cont'd)

Component	Failure Mode	Failure Causes	Failure Effect	Failure Detection Methods	Notes
Letdown Back Pressure Control Valve	a. Fails to operate properly in response to system pressure.	Valve operator malfunction. Mechanical binding.	Possible flashing to steam in letdown heat exchanger. Reduced letdown flow. Relief valve lifting.	Letdown heat exchanger pressure and temperature indications.	
	b. Fails Closed	Loss of air or electrical power. Spurious signal.	Loss of letdown flow. Possible pressure increase, and relief valve operation.	Letdown pressure and flow indication. Valve position indication. Pressurizer level indication.	
Boron Metering System	a. False indication of boron concentration.	Electrical or mechanical malfunction.	No direct system effect.	Erroneous high or low boron concentration signal.	
Purification Filter Isolation Valves	a. Fails Open	Mechanical binding.	Unable to isolate purification filter.	Letdown flow indication.	
	b. Fails Closed	Mechanical binding.	Loss of flow through purification filter.	Filter differential pressure indication.	
Purification Filter	a. Does not filter	Filter element failure.	Particle buildup in ion exchangers.	Differential pressure indication. Coolant sampling.	
	b. Blocked	Particulate matter buildup.	Reduced letdown flow.	Filter differential pressure and flow indication.	

Table 5.3 (Cont'd)

Component	Failure Mode	Failure Causes	Failure Effect	Failure Detection Methods	Notes
Ion Exchanger Bypass Valve	a. Fails Open	Valve operator malfunction. Mechanical binding.	Unable to bypass ion exchangers on high letdown temperature. Possible damage to ion exchanger resin.	Ion exchanger flow indication. Valve position indication.	
	b. Fails Closed	Loss of air or electrical power. Valve operator malfunction. Mechanical binding.	Ion exchangers bypassed, fission product buildup in primary coolant.	Valve position indication. Ion exchanger flow indication.	
Ion Exchangers	a. Ineffective purification	Degraded or wrong resin.	Decreased boron removal or increased fission product buildup in primary coolant.	Process radiation monitor. Boron sampling.	
	b. Plugged	Particulate contamination.	Decreased letdown flow.	Ion exchanger differential pressure and flow indication.	
	c. External Leakage	Corrosion. Manufacturing defect.	Primary coolant leak outside of containment.	Local radiation monitors. Ion exchanger pressure indication.	
Letdown Strainer Inlet Isolation Valve	a. Fails Open	Mechanical binding.	Unable to isolate letdown strainer.	Valve position indication.	
	b. Fails Closed	Mechanical binding.	Unable to establish letdown flow through ion exchangers.	Valve position indicator.	

Table 5.3 (Cont'd)

Component	Failure Mode	Failure Causes	Failure Effect	Failure Detection Methods	Notes
Letdown Strainer	a. Plugged	Containment buildup.	Reduced letdown flow.	Differential pressure through strainer indication.	
	b. Fails to strain properly	Strainer element failure.	Particulate and resin deposits in VCT.	Differential pressure through strainer indication.	
	c. External leakage	Corrosion. Manufacturing defect.	Primary coolant release outside of containment.	Local radiation monitors.	
Letdown Strainer Isolation Valve	a. Fails Open	Mechanical binding.	Primary coolant diverted to VCT.	Valve position indication.	
	b. Fails Closed	Mechanical binding.	Unable to establish letdown flow through ion exchangers to VCT.	Valve position indication. VCT level indication.	
VCT Bypass Valve	a. Fails Open	Valve operator malfunction. Mechanical failure.	Unable to bypass letdown flow to boron management system.	VCT level indication. Valve position indication.	
	b. Fails Closed	Valve operator malfunction. Spurious signal.	Unplanned release of primary coolant to boron management system. VCT level decrease.	VCT level indication. Valve position indication.	
VCT Hydrogen and Nitrogen Isolation Valves	a. Fails Open	Mechanical failure.	No impact on system performance.	Valve position indication.	
	b. Fails Closed	Mechanical failure. Contamination.	Unable to provide Hydrogen and Nitrogen to VCT. Low VCT pressure.	VCT pressure indication. Valve position indication.	

Table 5.3 (Cont'd)

Component	Failure Mode	Failure Causes	Failure Effect	Failure Detection Methods	Notes
VCT Gas Relief Valve	a. Fails Open	Mechanical binding. Contamination. Setpoint drift.	Loss of VCT Hydrogen or Nitrogen overpressure to vent gas system.	Waste gas surge tank pressure indication. Valve position indication.	
	b. Fails Closed	Mechanical failure. Blockage. Set point drift.	Loss of overpressure protection for blanket gas and purge header.	VCT pressure indication. Valve position indication.	
Volume Control Tank	a. External Leakage	Corrosion. Manufacturing defect.	Release of primary coolant outside of containment.	VCT level indication.	
	a. Fails Open	Mechanical failure. Valve operator malfunction.	VCT draindown, loss of suction flow to charging pump.	VCT level indication, valve position indication.	
RCP Controlled Bleedoff Relief Valve Stop	b. Fails Closed	Mechanical failure. Loss of air or electrical power.	Unable to establish charging flow from VCT.	Valve position indication. VCT level indication.	
	a. Fails Open	Mechanical failure. Valve operator malfunction.	Unable to isolate relief valve on loss of ac power transient resulting in reduced primary coolant inventory.	Valve position indication. VCT level indication.	
	b. Fails Closed	Mechanical failure. Valve operator malfunction. Spurious signal.	Loss of bleed-off header over pressure protection.	Valve position indication.	

Table 5.3 (Cont'd)

Component	Failure Mode	Failure Causes	Failure Effect	Failure Detection Methods	Notes
RCP Bleedoff Containment Isolation Valve	a. Fails Open	Mechanical failure. Valve operator malfunction.	Partial loss of containment isolation capability.	Valve position indication.	
	b. Fails Closed	Loss of electrical power. Mechanical failure. Valve operator malfunction.	Loss of all controlled bleed-off to VCT. Possible damage to RCP seals. Overpressure of bleed-off line.	Valve position indication.	
RCP Bleedoff Throttle Valve	a. Fails Open	Mechanical failure. Binding.	Unable to throttle controlled bleed-off flow properly.	VCT level indication. Bleed-off flow indication.	
	b. Fails Closed	Mechanical failure. Binding.	Unable to establish controlled bleed-off flow to VCT.	Valve position indicator. Bleed-off flow indication.	
Chemical Addition Tank	a. External Leakage	Manufacturing defect. Corrosion.	Chemical solution spill. Reduced chemical addition capability.	Chemical addition tank level indication.	Tank is not a storage tank, and is normally empty. Used to mix required chemical addition solution, and then add to primary coolant.
Primary Makeup Line Manual Isolation Valves	a. Fails Open	Mechanical failure. Contamination.	Primary leakage.	Valve position indication.	
	b. Fails Closed	Mechanical failure.	Unable to establish makeup flow to VCT.	VCT tank level indication. Valve position indication.	

Table 5.3 (Cont'd)

Component	Failure Mode	Failure Causes	Failure Effect	Failure Detection Methods	Notes
Primary Makeup Flow Control Valve	a. Fails Open	Mechanical binding. Valve operator malfunction.	High primary makeup water flow rate. Possible deboration of primary system.	Low boron indications. VCT level indication.	
	b. Fails Closed	Mechanical binding. Valve operator malfunction.	Low primary make-up water flow rate. Possible overboration.	High boron indications. VCT level indication.	
Primary Water Supply Check Valve	a. Fails Open	Mechanical failure. Contamination.	Possible back leakage of boric acid into makeup water lines. Boric acid precipitation.	VCT level indication.	
	b. Fails Closed	Mechanical failure.	Unable to establish primary makeup water flow. Possible over boration of primary system.	Low flow indication. High discharge pressure for reactor makeup water pumps.	
Makeup Control Stop Valve to VCT	a. Fails Open	Valve operator malfunction. Spurious signal.	Loss of makeup flow. If during SIAS, reduced boron solution due to diversion to VCT.	Valve position indication. Makeup flow indication.	
	b. Fails Closed	Mechanical failure. Valve operator malfunction.	Unable to establish makeup flow to VCT.	Valve position indication. Makeup flow indication.	
Boric Acid Batching Tanks	a. External Leakage	Manufacturing defect. Corrosion.	Boric acid solution loss.	Batching tank level indication.	

Table 5.3 (Cont'd)

Component	Failure Mode	Failure Causes	Failure Effect	Failure Detection Methods	Notes
Boric Acid Pumps	a. Operating Pumps Fails	Shaft shear.	Loss of normal boron addition. Boric acid precipitation. Failure of boric acid tank heater, and heat trace.	Pump flow and pressure indication. Boric acid tank level indication. Circuit breaker indication light.	
		Motor failure. Electrical failure. Loss of suction. Loss of power.			
	b. Spurious Start	Spurious signal.	Possible overborator of RCS.	Pump flow and pressure indication. Boric acid tank level indication. Circuit breaker indication lights.	
Boric Acid Pump Discharge Check Valves	c. Standby Pump Fails	Mechanical binding. Motor failure. Loss of suction.	Loss of redundancy. Possible loss of borator supply.	Pump flow and pressure indication. Circuit breaker indication lights.	
		Seat leakage. Contamination.	Possible small reduction in boron addition flow due to leakage in standby pump discharge lines.	Boric acid makeup tank level indication.	
	a. Fails Partially Open	Mechanical binding. Blockage.	Unable to establish normal boron addition flow.	Pump discharge pressure and flow indication.	
	b. Fails Closed				

Table 5.3 (Cont'd)

Component	Failure Mode	Failure Causes	Failure Effect	Failure Detection Methods	Notes
Boric Acid Makeup Flow Control Valve	a. Excessive Flow Restriction	Shaft binding. Valve operator malfunction.	Low boric acid solution flow rate. Possible primary coolant deboration.	Low boron concentration in primary coolant. Boric acid flow indication.	
	b. Insufficient Flow Restriction	Shaft binding. Valve operator failure.	Excessive boric acid flow rate. Overboration of primary coolant.	Boric acid flow indication. Boric acid pump discharge pressure indication.	
Chemical Addition Metering Pump	a. Pump Fails to Operate	Loss of power. Mechanical degradation.	Unable to add chemical solution to primary coolant system.	Pump discharge and flow indication. Chemical addition tank level indication.	
Refueling Water Storage Pool to Charging Pump Suction Check Valve	a. Fails Open	Contamination buildup.	Potential back leakage of primary coolant in RWSP when charging from VCT.	Reactor water storage pool level indication.	
	b. Fails Closed	Mechanical failure. Blockage.	Unable to switch charging pump from VCT to RWST on low VCT level. Loss of charging flow.	Pump suction pressure indication.	

Table 5.3 (Cont'd)

Component	Failure Mode	Failure Causes	Failure Effect	Failure Detection Methods	Notes
Refueling Water Storage Pool to Charging Pump Suction Isolation Valve	a. Fails Open	Seat leakage. Spurious signal. Valve operator malfunction. Mechanical failure.	Unwanted addition of refueling water to primary system. Loss of RWST inventory. Increase in boron concentration.	Charging pump suction pressure and flow indication.	
	b. Fails Closed	Mechanical failure. Valve operator malfunction.	Loss of charging flow. Unable to switch pump suction from VCT to RWST.	Charging pump suction pressure and flow indication.	
Charging Pump Suction Header Relief Valve	a. Opens Spuriously or Fails to Reset.	Mechanical failure. Setpoint drift.	Gradual loss of primary coolant to boron management system.	VCT and boron management system tank level indications. Valve position indication.	
	b. Fails Closed	Mechanical failure. Blockage. Setpoint drift.	Loss of overpressure protection.	Charging header pressure indication. Valve position indication.	
Charging Pump Suction and Discharge Isolation Valves	a. Fails Open	Mechanical failure.	Unable to isolate pump for testing.	Valve position indication.	
	b. Fails Closed	Mechanical failure.	Loss of charging flow.	Valve position indication.	

Table 5.3 (Cont'd)

Component	Failure Mode	Failure Causes	Failure Effect	Failure Detection Methods	Notes
Charging Pump Discharge Pressure Relief Valves	a. Opens spuriously or fails to reset	Setpoint drift. Contamination.	Reduced charging flow.	Charging pump discharge flow and pressure indications. Valve position indication.	
	b. Fails Closed	Mechanical failure. Blockage.	Loss of discharge line overpressure protection.	Valve position indication.	
Charging Pump	a. Fails to Operate	Loss of electrical power. Mechanical seal failure. Low suction head.	Loss of charging flow. Low pressurizer level. High letdown temperature.	Pressurizer level indication. Charging pump discharge flow and pressure indication. Circuit breaker monitoring lights. High letdown reheat exchanger letdown temperature.	
	b. Standby Pump Fails to Start	Loss of electrical power. Mechanical failure.	Loss of redundancy. Unable to provide required charging flow.	Charging pump discharge pressure and flow indication. Circuit breaker monitoring lights.	
	c. Spurious Start	Electrical power supply malfunction. Switching failure.	Sudden excess charging flow. Pressurizer level increase. Rapid boron concentration change.	Charging pump flow and discharge pressure indication. Pressurizer and VCT level indication. Boron concentration in primary system. Circuit breaker monitoring lights.	

Table 5.3 (Cont'd)

Component	Failure Mode	Failure Causes	Failure Effect	Failure Detection Methods	Notes
Charging Line Containment Valve	a. Fails Open	Mechanical failure. Loss of electrical or air supply.	Unable to isolate charging line.	Valve position indication.	
	b. Fails Closed	Mechanical failure. Spurious signal.	Unable to establish primary charging flow.	Charging pump flow and pressure indication. Valve position indication.	
Auxiliary Spray Valves	a. Fails Open	Valve operator malfunction. Spurious signal.	Possible inadvertent depressurization of primary system.	Pressurizer level and pressure indications.	
	b. Fails Closed	Loss of power. Mechanical failure. Valve operator malfunction.	Loss of one spray path.	Valve position indication. Pressurizer level and pressure indication.	
Charging Isolation Valves	a. Fails Open	Mechanical failure. Valve operator malfunction.	Unable to terminate charging flow.	Valve position indication.	
	b. Fails Closed	Loss of electrical power. Mechanical failure. Valve operation malfunction	Loss of one primary charging path.	Valve position indication.	

6. CVCS INSPECTION, SURVEILLANCE, MONITORING AND MAINTENANCE REVIEW (ISM&M)

Primarily because of the safety-related function of providing high pressure injection, RCP seal injection, containment isolation and emergency boration, many of the system components are required to be tested and inspected to ensure their operational readiness. These are performed in accordance with several requirements, including ASME Section XI Inservice Testing¹⁸, Appendix J,¹⁹ and the plant Technical Specifications.²⁰⁻²² Specific testing requirements are discussed in Section 6.1.

To supplement the operating data obtained from the review of the databases, a plant from each NSSS design (W, CE, and B&W) was visited to obtain additional system ISM&M data. A primary objective of these visits was to obtain the perspective of plant personnel on CVCS aging. Section 6.2 presents the results of these surveys.

6.1 Inspection, Surveillance, and Monitoring Practices

Active components of the CVCS system are inspected periodically to ensure their operational readiness. For those plants where the CVCS system is considered a safety-related system, the charging and boric acid transfer pumps must be tested in accordance with ASME Section XI, which requires quarterly measurements of pump flow, vibration, and head. The charging pumps are tested individually during normal plant operation. The boric acid transfer pumps, on the other hand, are tested using a recirculation loop that returns to the boric acid tank to prevent the introduction of highly borated water into the RCS and consequently a transient or possibly a plant shutdown. The performance parameters are measured and compared to reference values. For these plants, the valves must also be tested in accordance with ASME Section XI, which requires exercising the valves

quarterly, or during shutdowns, if quarterly testing is impractical, and leak-testing those CVCS valves that are containment isolation valves every 2 years. Relief valves are set-point tested every 5 years in accordance with Section XI. Section XI also provides inspection requirements for Class 1,2 and 3 pressure retaining components (e.g., pressure testing and non-destructive testing of welds).

The Technical Specifications also specify surveillance requirements for portions of the CVCS system that provide boration to the RCS and, for Westinghouse plants, RCP seal injection.

The system tests and inspections performed for CVCS are summarized in Table 6.1.

6.2 Specific Plant Insights

6.2.1 Westinghouse

The Westinghouse plant visited was a 16 year old, four loop, 1130 MWe unit. The CVCS system at this facility is a conventional design without boron thermal regeneration capability. Three charging pumps are provided, one positive displacement pump for normal charging, and two centrifugal pumps for high pressure injection. Two mixed bed, one cation bed, and two deborating demineralizers are used to maintain proper coolant chemistry.

The CVCS system has operated reliably over the past five years. During this period the overall plant unavailability, due to component failure, was less than 2%, however, the CVCS system did not contribute to this unavailability. Certain specific maintenance problems were identified during discussions with cognizant plant personnel, particularly with the boric acid and positive displacement charging pumps.

The boric acid addition and transfer pumps posed continual maintenance problems. The mechanical seals on these pumps failed

Table 6.1 Inspection, Surveillance and Monitoring Practices for the CVCS System

Component	IS&M Practice	Frequency
Valves	Verify correct position of valves in the boron injection flow path ² Verify RCP seal injection throttle and control valve position ² (Westinghouse) Verify stroke time ¹ Verify full stroke (check valves) ¹ Verify valve seat leakage ^{1,3} Verify relief valve set pressure ¹ Verify automatic valves actuate on safety injection actuation signal ²	31 days 31 days Quarterly/cold shutdown Quarterly/ Cold shutdown/refueling ⁴ 2 years 5 years 18 months
Pumps (Charging and Boric Acid Makeup)	Verify pump head within limits ¹ Verify pump flow within limits ^{1,2} Verify pump vibration within limits ¹	Quarterly Quarterly, 18 months Quarterly
Piping and pressure retaining components	Verify no system external leakage ¹ Hydrostatically test system ¹ Verify temperature of heat traced portion ² Surface or volumetrically examine selected welds ¹ Examine bolting > 2 in. ¹	3 years 10 years 7 days 10 years 10 years
Boric Acid Storage and Refueling Water Tanks	Verify boron concentration ² Verify volume ² Verify solution temperature ² Verify RWT temperature when the outside temperature is < 35F ^{o2}	7 days 7 days 7 days 24 hours

- 1. ASME Section XI requirement
- 2. Technical Specification requirement
- 3. Appendix J requirement
- 4. Relief from Section XI requested

approximately every two months. To rectify this recurring problem, the pumps were rebuilt and upgraded, including installing a larger pump shaft and larger stuffing box. An improved mechanical seal was also installed (Figure 6.1). Since these modifications were completed, both pumps have operated reliably for two years with no seal failures.

Another maintenance problem identified was the short service life of the packing on the positive displacement charging pumps. At this plant, the positive displacement pump is not safety-related, so the packing problem did not directly limit plant operation. Various types of solutions have been tried, and none has proven totally successful. Packing leakage from these pumps is a common problem throughout the industry, hence some plants have shortened the inspection interval to every 150 hours (operating).

As discussed in Section 6.1, most of inspections and monitoring for the system are made in accordance with the requirements of ASME Section XI, or Technical Specification requirements. The system piping is inspected for cracks and other defects using non-destructive examination techniques (e.g., eddy current). The pumps, both centrifugal and positive displacement, are tested quarterly (92 days) to check suction head. Additional measurements are taken to monitor pump head vs. flow at various points on the pump curve; and the results trended to detect any aging degradation in the pump. This testing method was instrumental in identifying a degraded rotating assembly. The assembly was replaced prior to failure, and the pump has performed satisfactorily since. Vibration measurements and lube oil analysis were also used as condition monitoring techniques. These were successful in identifying a gear tooth problem on a pump speed increaser. Upon pump disassembly, the missing gear tooth was verified, and the component replaced.

The licensee at this facility used Reliability Centered Maintenance (RCM) techniques to ensure that ISM&M was adequate. The primary advantage of this approach is that it focusses attention on each component individually, rather than grouping similar components. RCM also provides continuous feedback on the effectiveness of maintenance, and highlights the need for increased maintenance, if needed. An example of this approach was the maintenance applied to the diaphragm valves. Before instituting this approach, the diaphragms on all similar valves were replaced on the same frequency, regardless of operating history. With RCM, non-critical valves subject to less usage now have longer periods specified between routine diaphragm changeouts.

The single critical maintenance problem identified at this plant was associated with the boric acid portions of the system. The plant currently operates with a 20,000-22,000 ppm boric acid solution in the boron storage tank. This concentration is highly corrosive to the system materials, particularly carbon steel. Even the more corrosion resistant, stainless steel is not immune from corrosion attack at this concentration. Also, many of the stainless steel components use carbon steel fasteners that are subject to corrosion. In response to these concerns, this facility (as well as most other W plants) have begun examining the possibility of reducing the boric acid concentration to approximately 8,000 ppm in the boron storage tank. Though still corrosive, the corrosion rate will be less at this lower concentration.

6.2.2 Combustion Engineering

The CE plant visited has been in service for 18 years with a capacity of 845 MWe. The CVCS design consists of 3 positive displacement pumps which provide charging flow under normal operation. Upon receipt of a safety injection actuation signal (SIAS), all three pumps are started, and discharge concentrated boric

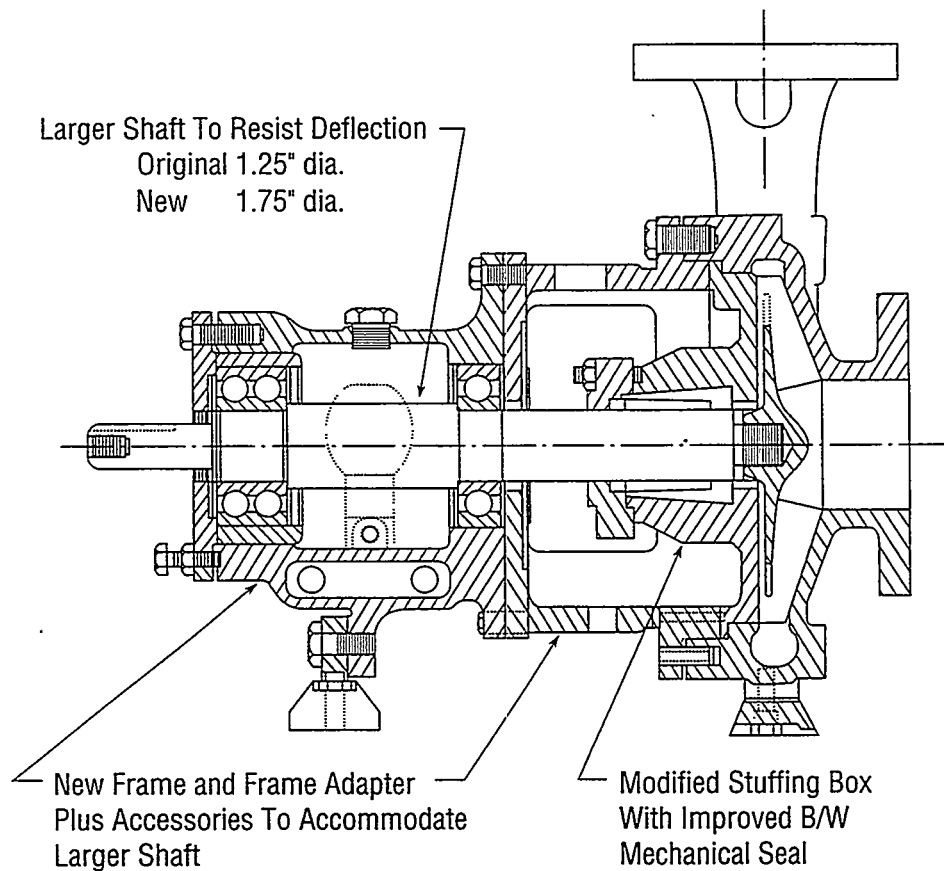

Figure 6.1 Boric acid transfer pump modifications

acid into the reactor coolant system. Two mixed-bed ion exchangers are used to remove the corrosion and fission products, and a deborating ion exchanger is used towards the end of a cycle to remove boron.

Several years ago, the owner of this facility reviewed (similar to RCM) all the plant systems to identify systems susceptible to failure. This review consisted of a plant staff survey and a documentation review. Specific documentation reviewed included LERs, nonconformance reports, design change requests, corrective maintenance records, and the NPRDS database. As a result of this effort, 27 systems were classified as problem systems, with six identified as most significant from a recurring problem and plant operation impact standpoint. These six

systems were saltwater cooling, CVCS, feedwater, auxiliary feedwater, service air, and compressed air. Further detailed evaluations were then performed on each of the systems to identify specific components which needed to be addressed.

The CVCS system ranked fifth in the plant staff survey, and first in the documentation review. In the final system ranking at this plant the system was ranked second, primarily due its associated maintenance costs. The majority of the failures noted were associated with positive displacement pumps, instrumentation failures, and boric acid pumps and heat tracing. Table 6.2 identifies the specific components failed and the system function affected.

Table 6.2 CVCS Problem Summary - CE Plant

System Function Affected	Component Failure
Charging	<ul style="list-style-type: none"> I. Positive Displacement Pumps <ul style="list-style-type: none"> 1. Packing Degradation 2. Suction Stabilizers <ul style="list-style-type: none"> - internal failures - vent failure 3. Discharge Desurger <ul style="list-style-type: none"> - internal failures 4. Breakers 5. Relief Valves 6. Seal Water 7. Pump Valves II. Instrumentation <ul style="list-style-type: none"> 1. Flow meters 2. Pressure switch III. Valves <ul style="list-style-type: none"> 1. Auxiliary spray
Letdown	<ul style="list-style-type: none"> I. Demineralizers <ul style="list-style-type: none"> 1. Resin degradation II. Valves <ul style="list-style-type: none"> 1. Regenerative heat exchanger inlet 2. Excess flow check 3. letdown control III. Purification filter
Makeup	<ul style="list-style-type: none"> I. Piping II. Heat tracing and insulation III. Recorders IV. Boric acid storage tank level instrumentation V. Boric acid transfer pumps <ul style="list-style-type: none"> 1. Mechanical seals 2. Power supplies

Positive displacement charging pump problems were foremost at this plant, primarily because of the impact of these failures. The pumps had frequent packing leaks, reduced capacity, and failed to start on several occasions.

The lifespan of the pump packing has been the subject of extensive investigation, testing and development. Factors which affect the life of the packing include the material, seal water flow, proper parts and maintenance, and pump operation. Plant configurations and operating time will also affect packing life. To maximize purification flow, some plants run two pumps continuously, others only run one, leaving the other pump on standby. Table 6.3 provides an overview of the frequency of maintenance and replacement of the packing at CE plants; there are significant variations between plants. Some plants replace the packing during refueling outages, while others have to do this much more frequently.

Experience indicates that the EDPM packing material degrades rapidly without adequate seal water. The system used at this plant to provide the seal water operated on a thermal siphon principal, and was not providing adequate wetting and cooling. A Kevlar-based material was found to provide longer life and to be less susceptible to seal water flow. Other factors which affect packing life were found to be dimensional variations and incorrect maintenance. This plant also recommended that specific leak rates be developed to ensure consistent changeout criteria.

Vibration from positive displacement pump operation also resulted in accelerated packing wear. An effective suction stabilizer and properly functioning desurger were found to be critical to ensuring the pump's smooth operation. In addition to providing a reservoir for the erratic suction flow inherent with positive displacement pumps, the suction stabilizer was also designed to remove entrained gases. If the gases were not removed from the pump suction, cavitation-like effects occurred and a temporary

loss of lubrication to the packing was possible. The discharge desurger is designed to attenuate 90% of the pulsations in the discharge piping. Proper functioning is related to the bladder precharge, with the higher precharge resulting in greater damping.

Pump operation characteristics were also found to result in aging degradation. The positive displacement pumps are required to start and pick up full load immediately which did not allow for the pump parts to be sufficiently lubricated prior to full load demands. To rectify this concern, a recirculation line with a control/isolation valve was installed to allow pump starting without load, and ease its flow contribution into the system.

Problems associated with boric acid storage and flow also accounted for significant operational effects. Stress corrosion cracking of the piping was promoted by the insulation cement used on the heat traced piping. The cement mixture contained halogens, which in the particular operating environment, accelerated cracking. This plant, similarly to the W plant, investigated the potential for reducing the boric acid concentration; this would reduce the need for heat tracing, and the associated problems caused by boric acid.

6.2.3 Babcock & Wilcox

The B&W plant visited was a 19 year old, 792 MWe plant. The Makeup and Purification System utilized consists of three centrifugal makeup pumps which provide both normal charging and high pressure injection for accidents. Two mixed-bed demineralizers provide for reactor coolant chemistry control.

At this plant, failures of the Makeup and Purification System did not contribute to plant downtime and unavailability. Interviews with plant personnel revealed that the system has been very reliable, with failures of the letdown coolers and motor-operated valves being the only ones of note.

Table 6.3 Summary of Pump Packing Type and Failure Rates

Plant(s)	Plunger Type	Replacement Frequency and Trend
Arkansas Nuclear 1 and 2	Stainless steel coated with Colmonoy #72	Recently had to replace during repacking at 1000-2000 hours, originally replaced every 12 to 18 months.
Calvert Cliffs 1 and 2	Stainless steel coated with Colmonoy #72	Replacing during each repacking at 2000-2500 hours, trend is increasing with packing life.
Fort Calhoun	Stainless steel coated with Colmonoy #72	Not provided.
Millstone Point 2	Type 316 stainless steel coated with Colmonoy #72	Change out during each plant refueling overhaul.
Palisades	Stainless steel coated with Colmonoy #72	Replace once per year
Palo Verde Units 1,2 & 3	Type 316 stainless steel coated with Colmonoy #72	Replace every 4-12 months depending on pump usage.
St. Lucie Units 1 and 2	Stainless steel coated with Colmonoy #72	Replace during each repacking at 2000 hours, trend is increasing with packing life.
San Onofre Units 2 and 3	Type 316 stainless steel coated with Colmonoy #72	Replace every 4-8 months.
Waterford 3	Type 304 stainless steel coated with Colmonoy #72	Replace every 2-3 years.

Several years ago, the plant experienced recurring tube leaks in the letdown coolers. The units were replaced, but recurred within a year. A root-cause analysis determined that the failures were due to a design problem which resulted in high cyclic stresses in the tubes during temperature transients. A contributing factor was the plant system configuration which prevented both coolers from being operational simultaneously. A plant modification rectified

this situation, and in turn reduced the magnitude of the temperature transients. Following these actions, letdown cooler operation has been satisfactory.

One instance was noted of a rotor degradation in the charging pump by trending the IST test results. The rotor was rebuilt, and the pump has operated successfully since.

Similar to the Westinghouse plant discussed in Section 6.1, reliability centered maintenance techniques were used to evaluate the system. From this review, the licensee determined that maintenance was adequate. Of the 255 maintenance tasks identified through RCM, only 40 (16%) were not presently being done and were subsequently added to the program. These tasks were associated with several makeup valves and instrumentation (i.e., pressure transducers). In addition to identifying the missed inspections, the RCM process also identified other instruments in the makeup loop with the same identifier. One instrument which was not being maintained provided indication of total seal injection flow in the control room; this indication may have been erroneous, or out of calibration due to lack of maintenance. Another instrument which was not being maintained provided a RCP interlock signal; here, continued lack of maintenance could have caused a reactor trip.

Identification and correction of these deficiencies has resulted in a projected savings of revenue which would of been lost in the event of a plant shutdown.

6.3 Summary

A complete understanding of system and component degradation and failure due to aging may not always be obtained from reviewing the failure databases. The insights obtained from cognizant plant personnel familiar with the systems and components are also critical in understanding system aging. The information in this Section was obtained from plant visits, and discussions with cognizant system engineers, from one W, CE, and B&W plant. Plant data reviewed were for the same time frame (1988-1991), so as to coincide with the failure database review. This information confirmed the trends seen from the failure databases (Section 4). Since the CVCS also provides for high pressure injection during emergencies, the specific

maintenance, inspection, testing and monitoring programs ensure operational readiness. These are performed in accordance with Section XI and Technical Specifications, and in some instances have been modified due to the frequency of failures (e.g., positive displacement pump packing failures).

Based upon the plant specific system reviews completed, several component degradations (pump packing and boric acid storage) were found to be common. In addition, each plant utilized RCM techniques to improve system operability and reliability.

6.3.1 Pump Packing

The primary source of reactor coolant leakage was charging pump packing leaks. The majority of the reported leak occurrences were associated with positive displacement pumps, and did not compromise plant safety. In response, various packing designs and modifications were used, but to date, this still remains a problem at some plants. Westinghouse plants now have increased the inspection frequency from quarterly to weekly. Kevlar packing was found to be less susceptible to variations in seal water flow. Other causes of premature packing failure were attributed to dimensional variations, and incorrect maintenance.

6.3.2 Boric Acid

Another primary source of system failure was associated with boric acid storage tank leaks. Initially, the concentration of the boric acid solution in the boron storage tank was approximately 20,000 ppm. At these high concentrations, leaks have corroded both carbon steel and stainless steel components, caused instrumentation failures due to boric acid crystallization, and also heat trace failures. In response to these failures, many PWR plants have begun decreasing the concentrations of boric acid required to obtain a safe shutdown.

6.3.3 Reliability Centered Maintenance

The use of Reliability Centered Maintenance (RCM) to review the effectiveness of maintenance programs at nuclear plants has been used since the 1980's. It should result in decreased failure rates and improved availability.

Each of the three plants surveyed have successfully incorporated RCM techniques into the pre-ventive maintenance programs for the system. One benefit realized from RCM is that each individual component is reviewed and

maintained in accordance with its importance to safety. These reviews have identified critical components which were receiving inadequate, or no maintenance, and reduced unnecessary maintenance. Implementation of the program, and correcting the deficiencies identified, resulted in improved system operability and reliability. However, eliminating inspections and testing may also result in different component aging mechanisms and stressors. Maintenance frequency should be based upon failure frequency, and may need to be adjusted periodically.

7. USNRC AND INDUSTRIAL STUDIES

The PWR CVCS has been the subject of both NRC and industrial research. Many of these efforts have been in response to specific operational occurrences, such as reactor coolant leakages, and boric acid corrosion. Recent emphasis was placed on ALARA considerations by reducing the amount of cobalt containing materials used in the system pumps and valves, and replacing parts sensitive to other materials in order to reduce personnel exposure. This section summarizes some of the documents which have provided pertinent information in attaining the goals of the NPAR program. These also document the system and component failures and degradation caused by continued exposure to the operating and environmental stresses discussed in Section 3.

Since 1980, the NRC has addressed the PWR CVCS system by issuing Generic Letters and NRC Bulletins that alerted licensees to possible safety-related pump loss, pipe cracking due to high cycle fatigue, and potential corrosion problems associated with boric acid leakage. Each document is summarized below.

7.1 USNRC Generic Letters

7.1.1 **Generic Letter 88-05: Boric Acid Corrosion of Carbon Steel Reactor Pressure Boundary Components in PWR Plants**

This Generic Letter highlighted potential operating concerns with reactor coolant leaks below technical specification limits. The concern was related specifically to the corrosive properties of the dissolved boric acid in the reactor coolant when it contacted carbon steel components. Though none of the four specific operating incidents discussed directly affected the CVCS (one resulted in the corrosion of a high pressure injection nozzle which amounted to 67% of the wall thickness), the potential for these problems exists, particularly for the boric

acid transfer pumps, and associated piping and tanks.

Licensees were requested to determine potential locations where such small leaks could occur, and to define the specific inspection procedures and tests to detect and correct them. Particular emphasis was placed on bolted joints, primary coolant pumps where leakages occur at cover-to-casing connections as a result of defective gaskets, and defective welds.

Additional information attached to this Generic Letter provided specific corrosion rates as a function of boric acid concentration, temperature, and conditions (i.e., aerated, derated, or dripping). Corrosion rates as high as 400 mils per month were reported. Though boric acid is typically maintained at concentrations between 0 and 1 weight percent, coolant lost through leakage loses a considerable amount of moisture through evaporation, resulting in highly concentrated, corrosive solutions of boric acid.

7.2 NRC Bulletins

7.2.1 **Pipe Cracks in Chemical Volume Control Due to Excessive Charging Pump Vibrations**

This unnumbered NRC Letter, issued in 1978, informed licensees of a potential safety concern regarding pipe cracks resulting from vibratory loads associated with positive displacement pumps. High cycle fatigue pipe failures had been reported at both the suction and discharge sides of the pumps. At one PWR, a through wall crack occurred on a four inch diameter suction header.

The safety concern with this failure mechanism was paramount at plants which used positive displacement pumps for high pressure injection as well as charging. These cracks could result in the inability to provide HPI during an accident. Failure of these pipes would result in the loss of the borated water needed to furnish

negative reactivity during reactor cooldown, and during a postulated steam-line break. High cycle fatigue cracks could also affect normal charging and makeup functions.

7.2.2 NRC Bulletin No. 80-05 Vacuum Condition Resulting in Damage to Chemical Volume Control System Holdup Tanks

This Bulletin informed licensees of four incidents (at separate facilities) where holdup tanks buckled due to partial vacuum conditions in the system. A second concern was the potential for an unexpected radioactive leakage path to develop during abnormal conditions. The CVCS holdup tanks were identified as a potential leak path since normal letdown flow could be directed to the tanks under certain operating conditions (e.g., fuel failures). A combination of manual and automatic maneuvers in response to abnormal conditions could draw a partial vacuum in the holdup tanks, causing tank damage, and possibly rupture. Licensees were requested to evaluate the addition of vacuum breakers to the tanks to preclude such collapse. Such design modifications also were required to ensure that tanks with a cover gas (e.g., hydrogen cover gas in the Volume Control Tank) could admit the cover gas fast enough to keep up with the maximum rate of liquid removal from the tank. The vacuum breakers were also required to be included in a surveillance program to ensure proper operation, and that there was no coolant leakage.

7.2.3 NRC Bulletin No. 88-04: Potential Safety-Related Pump Loss

This Bulletin alerted PWR licensees to two operating problems which could result from miniflow operation. The first concern involved the potential for dead-heading one, or more, pumps which have a common miniflow line to two or more pumps, or other configurations which do not preclude pump-to-pump interaction during miniflow operation. The second concern was related to the installed miniflow capacity for

single pump operation. Though both of these concerns are operational, pump operation in these degraded conditions may accelerate aging.

When two centrifugal pumps operate in parallel, and one pump develops a higher head at the same flow than the other, the weaker pump may be dead-headed when the pumps are operating in the minimum flow mode. This head difference is not a problem at moderate to high flow because of the shape of the pump's characteristic curve in these regions. Centrifugal pumps demonstrate hydraulic instability at a point below the best efficiency point on the characteristic curve. These unsteady flow phenomena become progressively more pronounced as flow is further decreased, and may damage the pump by vibration, excessive forces on the impeller, and cavitation.

Though these problems were identified for RHR pumps, the same concern is applicable to CVCS pumps. Boric acid transfer pump's may have miniflow lines installed that allow IST and other operational tests for standby pumps without affecting plant operation. As stated in this Bulletin, based on problems associated with miniflow operation, manufacturers advise that pumps should have minimum flow capacities of 25% to more than 50% of best efficiency flow for extended operation to protect against hydraulic instability or impeller recirculation problems. Though miniflow operation may provide information on the pumps operational readiness, it may also subject the pump to deleterious stresses which could lead to pump degradation and premature failure.

7.3 Industrial Research

7.3.1 EPRI TR-100359 Volume 1 Nuclear Power Plant Resource Book²³

This two volume report (not publicly available) evaluates the effects of changes in plant conditions (i.e., coolant chemistry) or operations on components, systems, and other plant conditions. Information on the effects of

variations in primary side coolant chemistry have on plant components. This provides valuable information in understanding the impact of CVCS degradation in maintaining proper coolant chemistry. Extended degraded operation could decrease reliability of the primary system's structural components, affect fuel cladding integrity, and increase the radiation fields.

Another area of relevance to the CVCS discussed was the effect of preventive maintenance, and its frequency of performance, on component operability. Specific information is provided on valves, reactor coolant pumps (CVCS provides seal water cooling), and instrumentation and controls. Specific noteworthy maintenance practices and problems for each area are discussed.

This special report has numerous references which would be beneficial to plant operators in understanding the potential long term deleterious effects of degraded system operation. These conditions could result from normal system aging, or through inadequate maintenance practices on critical components (i.e., pumps and valves).

7.3.2 EPRI NP-5796 Valve Performance in PWR Chemical and Volume Control Systems²⁴

The main objective of this study, conducted by Westinghouse for EPRI, was to survey CVCS valves to determine the materials and performance of the valve hard facing and to determine the amount of cobalt released from CVCS valves. Approximately 66% of the valves used by plants contained no cobalt as shown on Table 7.1. The valve parts most likely to wear are the seats, cages, stems, and plugs (Figure 7.1).

This study concluded that CVCS valve wear contributes approximately 40% of the total cobalt input from all plant valves. Almost all of this input was from valves downstream of the VCT, since 90% of the cobalt released by valves upstream of the VCT was removed by the demineralizers. Also, the number of valves upstream of the VCT is small compared to the

system total. The remaining 60% of cobalt contained in the RCS was contributed equally from reactor coolant system valves and safety injection check valves. Of all the plant systems, the CVCS valves may potentially contribute the most cobalt into a plant. Table 7.2 shows the estimated cobalt input from corrosion and wear of cobalt-containing alloys from DC Cook. Check valves had wear rates four times greater than globe or gate valves.

The NPRDS data base was also searched for valve failure and maintenance data. Special efforts were made to identify evidence of maintenance and repair activities indicative of wear, such as part replacement and lapping seats. A large percentage of the data documented leaks from valve packing and gaskets, which concurs with the results of the operational experience reported in Section 4. These instances were typically corrected by repacking or re-gasketing the valves, and were not considered to be wear-related. The NPRDS study concluded that events concerning repair or replacement of potentially high cobalt wear parts in valves did not occur frequently (typically, once to twice per year), and therefore wear was not the cause of cobalt levels in the system.

7.4 Other Miscellaneous Reports Documenting CVCS Operating Events

7.4.1 Metallurgical Investigation of Cracking in the Boric Acid Piping at Prairie Island 1²⁵

This letter summarized preliminary findings of metallurgical investigations on a cracked boric acid piping discovered at Prairie Island 1. These cracks were found in the stagnant section of the piping from the boric acid storage tank to the centrifugal charging pumps. The evaluations consisted of surface examinations, metallographic, fractographic and chemical examinations.

The inner diameter of the failed piping was covered with a thick black oxide. The constituents of this oxide were not identified in this

**Table 7.1 Charging Flow Control Valve Wear Materials
in Certain Westinghouse Plants**

Plant(s)	Stainless Steel	Primarily High Cobalt	Some High Cobalt
Beaver Valley 1		X	
Beaver Valley 2			X
Braidwood 1 and 2	X		
Byron 1 and 2	X		
Callaway	X		
Cook 1 and 2		X	
Comanche Peak 1 and 2	X		
Diablo Canyon 1 and 2		X	
Farley 1 and 2	X		
Ginna	X		
Indian Point 2 and 3	X		
North Anna 1 and 2	X		
Point Beach 1 and 2	X		
Ringhals 2		X	
Ringhals 3 and 4			X
Robinson 2	X		
Trojan			X
Salem 1 and 2		X	
Seabrook 1	X		
Sequoyah 1 and 2		X	
Shearon Harris	X		
Summer	X		
South Texas 1 and 2	X		
Surry 1 and 2	X		
Turkey Point 3 and 4	X		
Vogtle 1 and 2			X
Watts Bar 1 and 2			X
Wolf Creek	X		
Zion 1 and 2	-	X	-
TOTALS	27	12	8

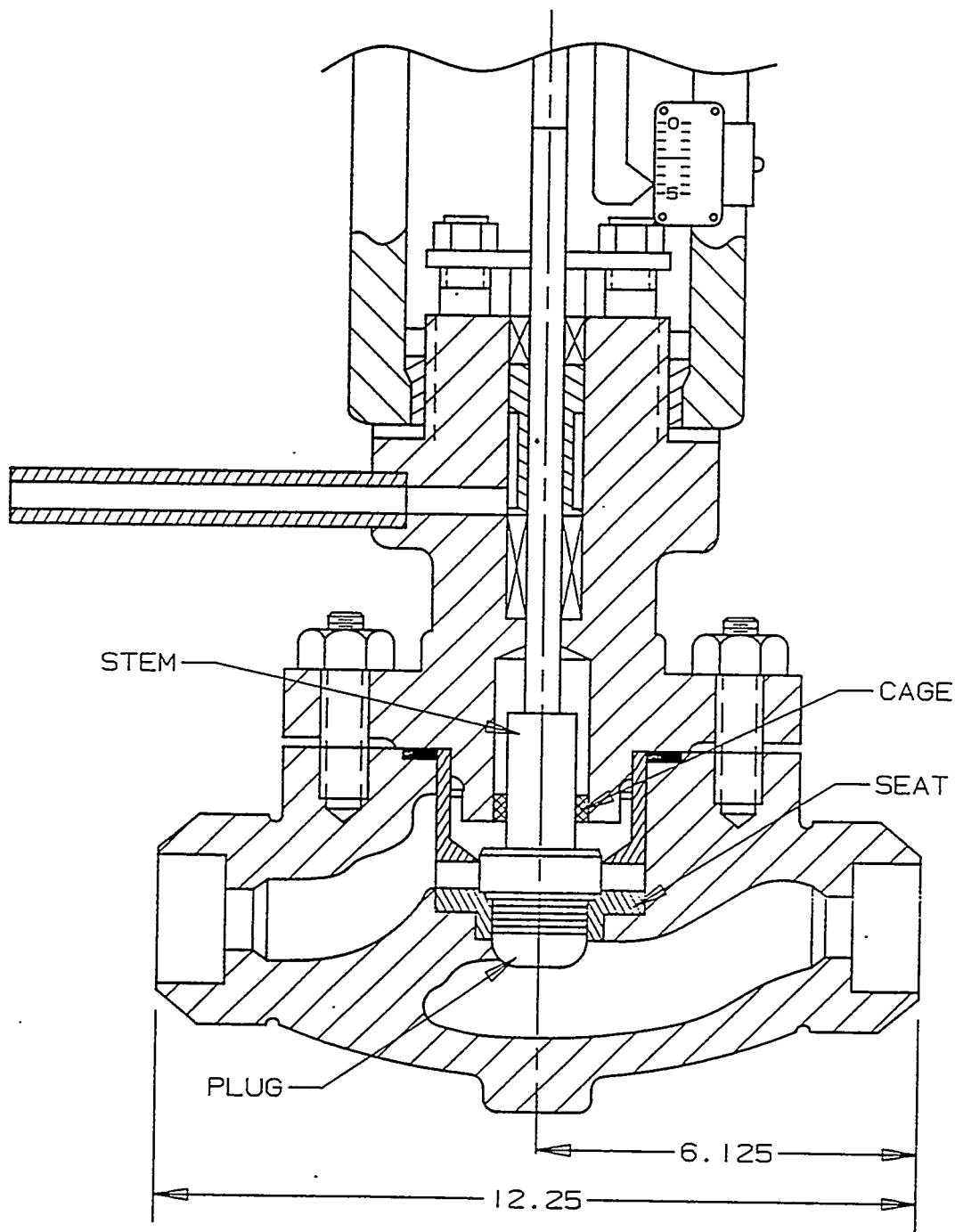

Figure 7.1 Wear parts in a typical charging flow control valve

Table 7.2 Estimated Cobalt Input from Corrosion and Wear of High Cobalt Alloys in CVCS Valves

Valve* Type	Total Area (in ²)	Area (dm ²)	Rel. Operating Time (Percent)	Cobalt Corrosion Rel. Rate (ndm)	Cobalt Input from Corrosion (mg/yr)	Cobalt Wear Rate (ndm)	Cobalt Input from Wear (mg/yr)	Total Cobalt Input (gr/yr)
Gate	112	7.2	100	0.2	17	1.5	130	0.15
Globe	267	17.2	100	0.2	41	1.5	310	0.35
Check	201	13.0	100	0.2	31	6.3	982	1.01
Globe	17	1.1	98	0.2	3	1.5	19	0.02
Globe	78	5.0	50	0.2	6	1.5	45	0.05
Gate	218	14.1	49	0.2	17	1.5	124	0.14
Globe	39	2.5	49	0.2	3	1.5	22	0.03
Check	120	7.7	49	0.2	9	6.3	285	0.29
Globe	17	1.1	2	0.2	-	1.5	-	-
Check	60	3.9	2	0.2	-	6.3	6	-
					124		1917	2.04

*Total number of valves = 31 downstream of VCT plus 40 in RCP seal bypass = 71 total

letter. Removal of this coating revealed numerous circumferential cracks beginning near a weld and extending 1 to 1 1/2 inches into the pipe. Metallographic sections of the cracks showed that they initiated on the inner diameter surface and propagated radially outward. The cracking behavior resembled typical chloride type cracking in Type 304 stainless steel. X-ray powder analysis of the surface oxide revealed evidence of chlorides in the oxide layer (up to 70 ppm).

The potentially corrosive nature of boric acid precipitate highlights the importance of maintaining it in solution. Efforts should be made to improve the reliability of piping heat trace and tank heaters to prevent these occurrences. These failures, as identified in the review of operating experience review in Section 4, present both an immediate problem, from the boric-acid precipitates obstructing flow, and a long term corrosion problem.

7.4.2 350 Gallon Leak From Chemical and Volume Control System²⁶

This voluntary special report, issued by Duke Power, documented a 300 to 350 gallon leak which occurred when the boron thermal regeneration system was placed in the recirculation mode at McGuire. As noted in Section 2, this portion of the system is not typically used, and was being sampled for corrosion inhibitor concentration and the presence of biological growth.

Shortly after flow was established in the boron thermal regeneration line, a decreasing level in the VCT was noted. Subsequent investigation by the plant operators revealed that valve 2NV-347 (Figure 7.2) was in the intermediate position, and opened the valve, which halted the decrease. Following this, high radiation alarms were received from the CVCS valve gallery. Operations personnel discovered coolant water on the floor, and estimated the leakage to be approximately 350 gallons. The source of the leak was not readily identified, and subsequent system pressure tests found that it was caused by

loose bonnet bolts on the mixed bed demineralizer sluicing resin isolation valve (2NV-350).

7.4.3 CVCS Letdown Line Water Hammer Event²⁷

In 1987, Houston Lighting and Power Co. reported snubber damage associated with the CVCS letdown line. The damage was caused by a water hammer event which occurred during hot functional testing. The root cause of the event was a system logic design error.

Upon a containment isolation signal, the containment isolation valves automatically closed, followed by the letdown stop valves ten seconds later. When these valves closed, the downstream pressure of the flow orifices increased, causing the relief valve to lift until the upstream and downstream pressure equalized. This resulted in a steam bubble formation due to the depressurization of the high temperature fluid. During normal operation, the line upstream of the flow orifice is maintained at RCS pressure, while the line downstream is normally maintained at 350 psig by a pressure control valve. Following the event, when the letdown stop valves were reopened to reinitiate letdown flow, reactor coolant at 567°F and 2200 psig contacted the fluid in the letdown line which was equalized by the relief valve pressure setting (600 psig and 490°F). The resulting steam bubble collapse resulted in the water hammer and snubber damage.

Design changes were initiated to change the automatic containment isolation signal from the letdown stop valves to the orifice isolation valves. This change prevented depressurization of the letdown piping upstream of the letdown orifice following containment isolation.

7.5 Summary

Age related operating failures of the CVCS components and system have resulted in both

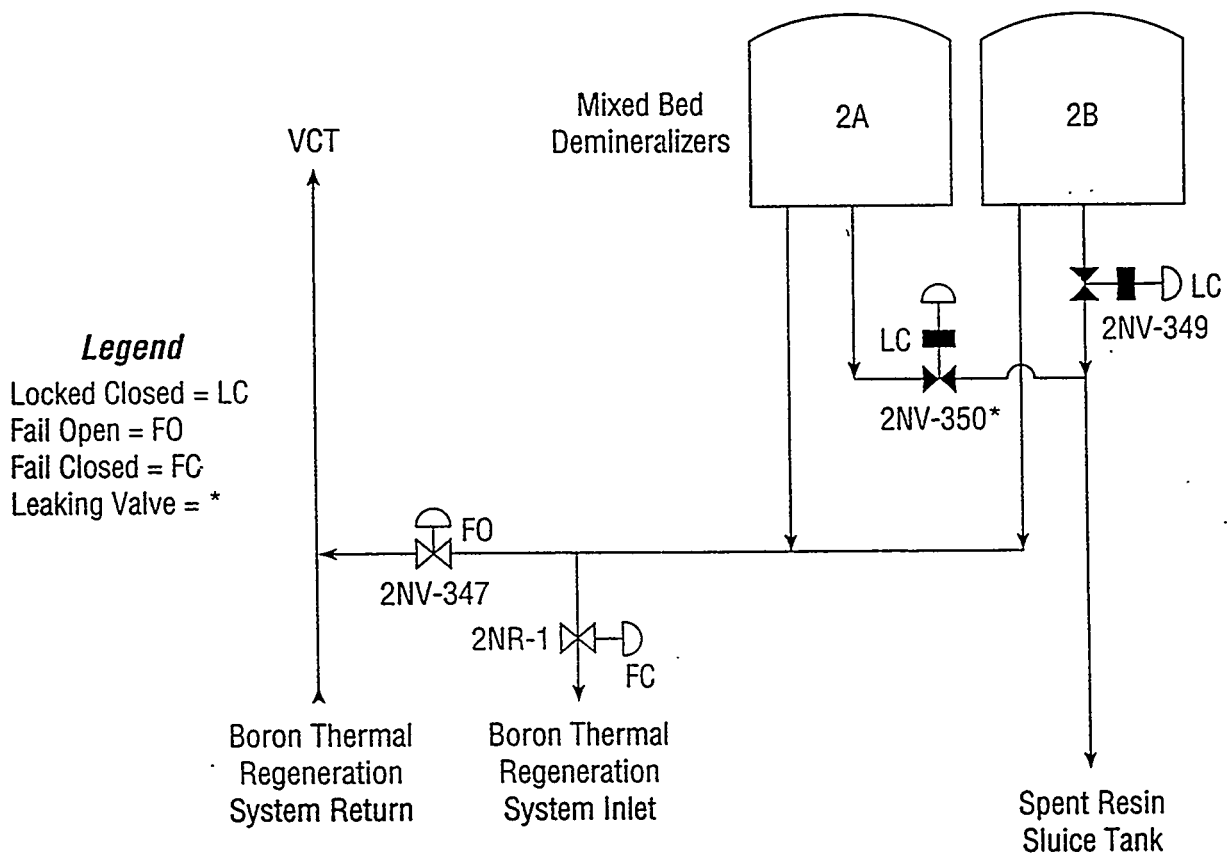

Figure 7.2 Flow diagram CVCS and boron thermal regeneration interface

NRC and industry studies. One of the main thrusts of the industry research was to determine the contribution of CVCS valve wear to plant cobalt buildup. The results of these studies concluded that these valves were a major source of cobalt, and that check valves wore at four times the rate of globe or gate valves. These studies agreed with the results of the operating experience analysis (Section 4) that primary leakage due to packing and gasket failure were the common failure mechanisms.

The studies also highlighted the susceptibility of components to normal and abnormal operating stresses. Piping failure due to high cycle fatigue from the operation of positive displacement pumps, chloride corrosion due to boric acid precipitate, and water hammer due to the improper valve closure in response to containment isolation were all reported. The buckling of holdup tanks due to partial vacuum, and the potential for pump damage when operated in the minimum flow condition were also highlighted.

8. EFFECT OF CVCS AGING ON CORE DAMAGE FREQUENCY

In an attempt to quantify the effect of aging upon CVCS performance, a PRA-based analysis was performed. This effort consisted of determining;

- 1) a base case core damage frequency (CDF) estimate based upon fault-tree analysis,
- 2) the major contributors (i.e., component failures, human errors) to the CDF, and
- 3) performing a parametric study which varied selected component failure rates to simulate the potential effect of aging related degradation on CDF.

As discussed in Section 2, the majority of the CVCS system functions are not safety related, and therefore the total system is not modelled in PRAs. However, the High Pressure Injection (HPI) subsystem, which shares many of the same components, is included in PWR risk assessments. Therefore, the HPI function, as modelled in the Surry PRA, and the Integrated Reliability and Risk Analysis System (IRRAS) was chosen as the basis for this study. IRRAS is a PC-based PRA code which creates and analyzes fault trees and accident sequences.²⁸ In the Surry PRA, failures of the HPI were contained in six of the top twenty-eight accident sequences. These six sequences accounted for 10% of the total core damage frequency (CDF).

The use of the HPI system as a surrogate for the CVCS necessitated a slight change in the analysis approach. Previous PRA analyses in support of NPAR used system unavailability as the measure of potential impact of aging for various systems (i.e., Containment Cooling,³³ Reactor Core Isolation Cooling³⁴). However, HPI has several operating modes depending upon the accident initiator. For example, a medium LOCA requires the automatic initiation of the system, a loss of decay heat removal

requires manual initiation to support feed and bleed operation, and an Anticipated Transient Without Scram (ATWS) requires emergency boration. Each mode of operation requires unique critical components. It was decided for this study to combine the accident sequences with HPI failures into a composite fault tree (HPI-SEQ). This tree utilizes CDF as a measure of potential aging effects rather than system unavailability. This tree, included in Appendix D, recognizes the relative importance of each HPI accident sequence and develops a CDF weighted ranking on HPI failures for all of the system operating modes. As such, the failure of the emergency boration valve (HPI-MOV-FT-1350) to open, which accounted for 60% of the unavailability of the emergency boration fault tree, contributed to individual cutsets which comprised approximately 1% of the CDF developed by the HPI-SEQ tree.

8.1 Discussion of Results

The HPI system (base case analysis) contributes to specific accident sequences which have a total CDF of 2.1E-5. The individual cutsets which contributed to this base case are presented in Table 8.1. This CDF is approximately five times greater than the comparable Surry CDF contribution. This difference is primarily due to the modelling of a single unit plant which was used for this study (The Surry PRA takes credit for recovery actions from Unit 2). The CDF magnitude is not critical, rather the fractional increases attributable to the parametric studies are the primary focus.

The HPI failures which contributed to the base analysis are shown in Table 8.2. Human error contributed to 49% of the HPI composite tree failures. The majority of this human error contribution (96%) was the failure of the operator to establish feed-and-bleed following loss of the decay heat removal systems (sequence T2LD2 in the composite tree contained in Appendix D). Other errors, such as failure to align the HPI in an alternate

Table 8.1 HPI Composite Tree Cutset Report

Cut No.	% Total	% Cut Set	Frequency	Cut Sets
1	32.0	32.0	6.674E-006	AFW-CCF-LK-STMBD, HPI-XHE-FO-FDBLD, IE-T2
2	48.2	16.2	3.380E-006	HPI-CCF-FT-115BD, IE-S3
3	54.5	6.2	1.300E-006	HPI-CKV-FT-CV25, IE-S3
4	60.7	6.2	1.300E-006	HPI-CKV-FT-CV410, IE-S3
5	64.2	3.5	7.341E-007	AFW-CKV-00-CV142, AFW-TDP-FS-FW2, HPI-XHE-FO-FDBLD, IE-T2
6	67.6	3.3	7.008E-007	AFW-CCF-FS-FW3AB, AFW-TDP-FR-2P6HR, HPI-XHE-FO-FDBLD, IE-T2
7	70.6	2.9	6.162E-007	CPC-CCF-LF-STRAB, IE-S3
8	72.8	2.2	4.745E-007	HPI-XVM-PG-XV24, IE-S3
9	74.9	2.0	4.205E-007	AFW-CKV-00-CV157, AFW-MDP-FS-FW3A, HPI-XHE-FO-FDBLD, IE-T2
10	76.9	2.0	4.205E-007	AFW-CKV-00-CV172, AFW-MDP-FS-FW3B, HPI-XHE-FO-FDBLD, IE-T2
11	78.8	1.9	3.994E-007	CPC-MDP-FR-SW10A, CPC-MDP-FS-SW10B, IE-S3
12	80.0	1.2	2.600E-007	HPI-CCF-FT-867CD, IE-S1
13	81.3	1.2	2.600E-007	HPI-CCF-FT-115BD, IE-S2
14	82.5	1.2	2.600E-007	HPI-CCF-FT-115BD, IE-S1
15	83.8	1.2	2.569E-007	AFW-CCF-FS-FW3AB, AFW-TDP-FS-FW2, HPI-XHE-FO-FDBLD, IE-T2
16	85.0	1.2	2.501E-007	HPI-CCF-FT-867DC, HPI-XHE-FO-ALTS3, IE-S3
17	86.1	1.1	2.336E-007	AFW-CCF-FS-FW3AB, AFW-TDP-MA-FW2, HPI-XHE-FO-FDBLD, IE-T2
18	87.1	.9	2.020E-007	HPI-MOV-FT-1350, IE-T, K, R
19	88.0	.9	1.917E-007	CPC-MDP-FR-SW10A, CPC-MDP-FR-SW10B, IE-S3
20	88.8	.7	1.586E-007	HPI-CCF-FT-867CD, HPI-XHE-FO-ALT, IE-S2

Table 8.1 (Cont'd)

Cut No.	% Total	% Cut Set	Frequency	Cut Sets
21	89.3	.5	1.170E-007	HPI-MOV-FT-1867C, HPI-MOV-FT-1867D, IE-S3
22	89.9	.5	1.170E-007	HPI-MOV-FT-1115C, HPI-MOV-FT-1115E, IE-S3
23	90.4	.5	1.170E-007	HPI-MOV-FT-1115B, HPI-MOV-FT-1115D, IE-S3
24	90.9	.4	1.000E-007	HPI-CKV-FT-CV25, IE-S1
25	91.4	.4	1.000E-007	HPI-CKV-FT-CV25, IE-S2
26	91.9	.4	1.000E-007	HPI-CKV-FT-CV225, IE-S2
27	92.4	.4	1.000E-007	HPI-CKV-FT-CV410, IE-S1
28	92.8	.4	1.000E-007	HPI-CKV-FT-CV410, IE-S2
29	93.3	.4	1.000E-007	HPI-CKV-FT-CV225, IE-S1
30	93.8	.4	9.984E-008	CPC-MDP-FR-SW10A, CPC-MDP-MA-SW10B, IE-S3
31	94.2	.3	7.947E-008	AFW-MDP-FS-FW3A, AFW-MDP-FS-FW3B, AFW-TDP-FR-2P6HR, HPI-XHE-FO-FDBLD, IE-T2
32	94.5	.3	6.732E-008	IE-T, K, PPS-XHE-FO-EMBOR, R
33	94.8	.3	6.674E-008	AFW-TNK-VF-CST, HPI-XHE-FO-FDBLD, IE-T2
34	95.1	.3	6.240E-008	HPI-MOV-FT-1115B, IE-S3, SIS-ACT-FA-SISB
35	95.4	.3	6.240E-008	HPI-MOV-FT-1115C, IE-S3, SIS-ACT-FA-SISB
36	95.7	.3	6.240E-008	HPI-MOV-FT-1115E, IE-S3, SIS-ACT-FA-SISA
37	96.0	.3	6.240E-008	HPI-MOV-FT-1115D, IE-S3, SIS-ACT-FA-SISA
38	96.3	.2	5.720E-008	HPI-CCF-FT-115BD, IE-T7, RCS-XHE-FO-DPRES
39	96.6	.2	5.720E-008	HPI-CCF-FT-867CD, IE-T7, RCS-XHE-FO-DPRES
40	96.8	.2	4.992E-008	CPC-CKV-00-CV113, CPC-MDP-FR-SW10A, IE-S3

CDF Contribution 2.082E-005

injection configuration after failures which disabled the normal injection path (sequences S2D1 and S3D1); and the failure to initiate emergency boration (sequence TKRD4), were much less significant contributors.

The second major group is the failure of the HPI motor-operated valves (MOVs) to operate (open or close) upon demand. This group contributed approximately 26% to the HPI failures. Eighty percent of the MOV contribution was attributable to the failure to open one or both of the two parallel reactor water storage tank (RWST) suction MOVs (1115B and D) (Figure 8.1). The HPI injection line, with its similar geometry of two normally closed, parallel MOVs (1867C and D) accounted for only 15% of the MOV contribution because of an alternate injection path available as a backup.

Check valve failures to open contributed 15% to the HPI failures. Ninety-five percent of this contribution was from failure of check valves CV410 and CV25 in the common suction line from the RWST to the charging pumps suction. The relatively minor contribution (5%) of check valve CV225 in the common portion of the injection line was also due to the availability of an alternate injection path.

HPI support system failures involving charging pump cooling or safety injection actuation accounted for 7% of the HPI failures. Plugging of manual valve XV24 in the charging pump suction line from the RWST accounted for 2% of the HPI failures. As noted in Section 4, manual valve failures accounted for a significant portion of the reported valve failures.

Equally significant to what does result in HPI failure, is what does not. Charging pump failures (failures to start, run, or unavailable due to maintenance) were not significant. Surry has three charging pumps with two divisions of support systems. The 1C charging pump train may be aligned to either Safety Injection Actuation System (SIAS) train, charging pump

cooling, and AC or DC power. The HPI success criteria requires flow from only one of the three available pumps. In standby systems, the common cause failure to start of three pumps would normally be a significant contributor to system unavailability. However, in the charging system, undetected demand failure (common cause or otherwise) can only disable the two standby pumps. Failures which are capable of disabling the operating pump within the time frame of interest are much less likely. Therefore the combined unavailability of all three pumps is a low probability event. The relatively significant contribution of the support systems reflect this. It is more likely that all three pumps will become unavailable due to malfunctions in the two charging pump cooling trains or the SIAS divisions.

A parametric study was also performed to simulate the effects of component aging upon the HPI contribution to CDF. The specific classes of failures (MOVs failure to operate, check valve and manual valve plugging) which could be impacted by aging degradation were adjusted by factors of 2, 5, and 10, and the revised HPI contribution to CDF recalculated. The results of this parametric study are shown in Table 8.3.

The large human error contribution (49%) to the base case HPI CDF contribution limits the importance of aging. For example, if the human error failure contribution (Table 8.2) approached 100%, the parametric study would show little or no sensitivity to aging. Conversely, if human error (or any other aging mechanism) were less significant the base case component failures and potential susceptibility to aging would become more significant.

In conformance with their contribution to the HPI base case CDF contribution, MOVs had the largest potential aging related impact on system performance. A factor of 10 increase in MOV unavailability resulted in a five times increase in the base case CDF. Check valve failures and manual valve plugging were less important. An order of magnitude unavailability

Table 8.2 A Listing of the Major HPI Failure Modes

HPI Failure Mode	Description	Typical Failure Notation	Failure Contribution
Human Error	Failures to initiate feed and bleed (FDBLD), realign HPI to an alternate injection path (ALT), or initiate emergency boration (EMBGR)	HPI-XHE-FO-FDBLD -ALT -EMBGR	49%
MOVs fail to open or close	Random or common-cause failures (CCF) of the RWST suction MOVs 1115B,D, the volume control tank MOVs 1115C,E, or the injection valves 1867C,D	HPI-CCF-FT-115BD HPI-MOV-FT-1867C	26%
Check valves fail to open	Check valves in the RWST charging pump, suction line (CV25, CV410), or the HPI injection line (CV225) fail to open	HPI-CV-FT-CV25	15%
Manual valve plugging	Plugging of the normally open manual valve in the RWST pump suction line	HPI-XVM-PG-XV24	2%
Support system failures	Charging pump cooling (CPC) and safety injection actuation system (SIS) failures	CPC-CCF-LF-STRAB SIS-ACT-FA-SISA	7%

1. See Table 8.1

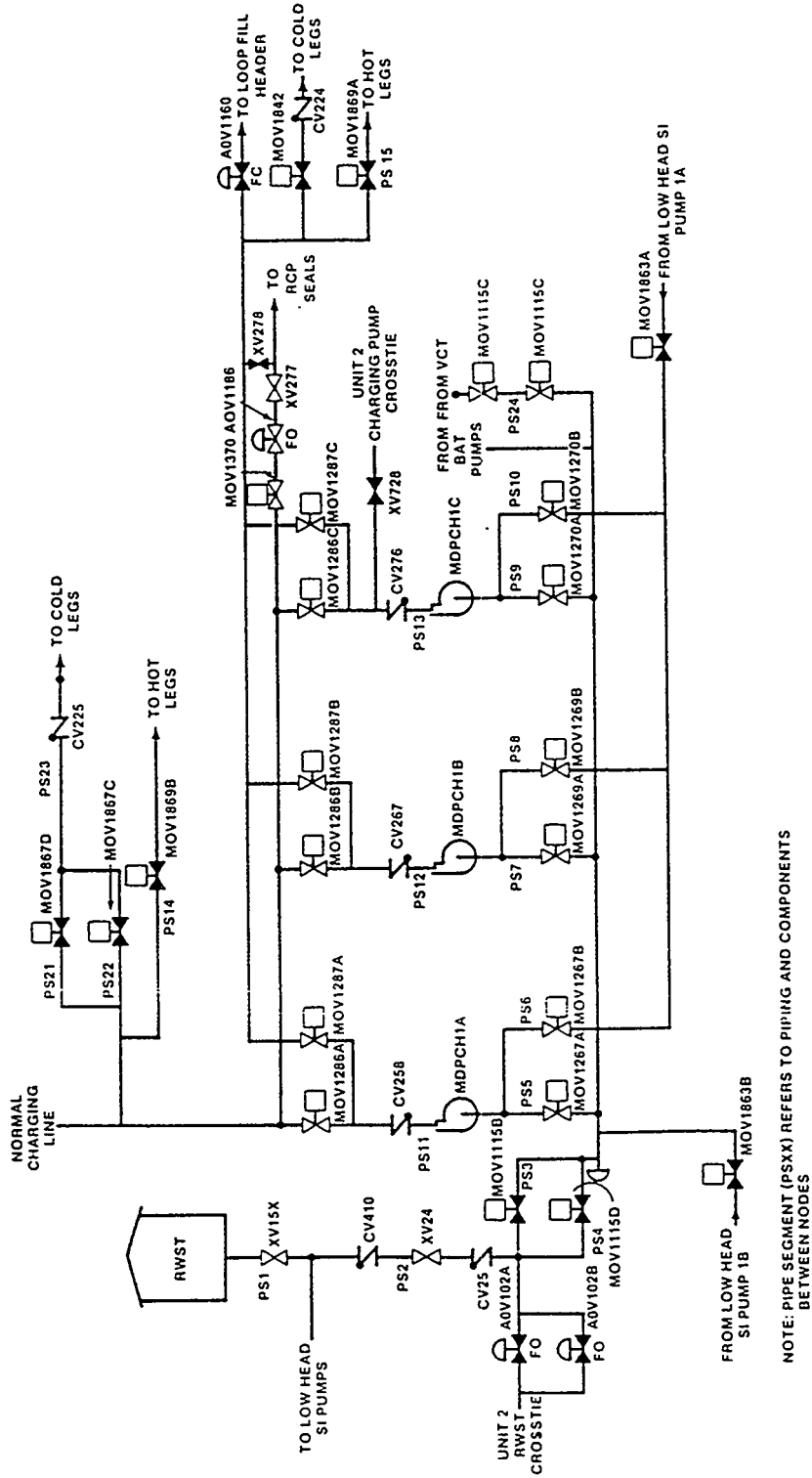

Figure 8.1 HPI Portion of CVCS

Table 8.3 Results of the Parametric Study

Group Description	Parametric Factor	Change Set (HPI-)	HPI CDF	
			Contribution	Factor*
Base Case	1	Base	2.1E-5	1.0
MOVs FTO/FTC	2	MOV.2	2.7E-5	1.3
	5	MOV.5	5.0E-5	2.4
	10	MOV.10	1.0E-4	4.8
Check Valves FTO	2	CV.2	2.4E-5	1.1
	5	CV.5	3.4E-5	1.6
	10	CV.10	5.0E-5	2.4
Manual Valve Plugging	2	PLG.2	2.1E-5	1.0
	5	PLG.5	2.3E-5	1.1
	10	PLG.10	2.6E-5	1.2
All Components**	2	ALL.2	3.1E-5	1.5
	5	ALL.5	5.9E-5	2.8
	10	ALL.10	1.4E-4	6.7

*Factor = Parametric CDF contribution/base case CDF
 **ALL = All HPI failures that are potentially subject to aging (MOVS + CVs + manual valves)

increase raised the HPI CDF contribution by factors of 2.4 and 1.2 respectively. As a limiting case, all of the components which could be affected by aging were included in the parametric study. This resulted in a seven fold increase in HPI CDF contribution over the base case.

8.2 Summary

From the review of the Surry PRA, it was found that the normally operating modes of the CVCS system are not modelled in PRAs since its functions are not safety-related. However, the High Pressure Injection System, which relies on many of the same components, is modelled. At Surry, the HPI was found to be of medium importance in the PRA, contributing to accident sequences which accounted for 10% of the total

CDF. The system, as modified to represent a single unit site, had a base case contribution of 2.1E-05.

Human errors, primarily the failure to initiate feed-and-bleed, were the major contributor (49%). The remaining portion was made up of component failures, with MOV operating failures being the most significant. The large human error component rendered the system somewhat insensitive to the potential component aging degradation. However, aging may have a significant impact upon system operability, particularly for the MOVs. When the unavailability estimate for MOV operating failures was increased by a factor of ten, the HPI CDF contribution increased by approximately five times. This highlighted the importance of monitoring and detecting age degradation before component failure.

9. CONCLUSIONS AND RECOMMENDATIONS

The PWR Chemical and Volume Control System provides both normal operating and emergency functions. During normal plant operation the system provides for letdown flow and cooling, reactor coolant chemistry control, reactor coolant pump seal cooling, and charging flow. During emergencies, charging pumps (in the majority of plants) are also used to provide high pressure injection. All of the functions are non-safety related with the exception of high pressure injection, emergency boration, RCP seal injection, and containment isolation. This study highlighted the importance of non-safety related systems to plant safety, especially for those components which are also used by safety related systems (i.e., charging pumps).

A Phase I aging assessment has been completed for each NSSS system design. Although each particular system design provides the same functions, design variations exist between plants and NSSS designs. A Failure Modes and Effects Analysis (FMEA) for each NSSS design was also completed. The CVCS has been the subject of several EPRI studies. These studies, and NRC Bulletins and utility reports documenting significant system degradations conclude that system aging has occurred, resulting in significant failure effects. These studies and Bulletins were reviewed.

Both the NPRDS and LER databases were reviewed for operating failure events from 1980 to 1991. However, due to the voluminous amount of events for this period (> 7000 failure records), the review concentrated on the 1988 to 1991 period (4029 failure records). Of these, 62% of the failures reported to NPRDS were aging related, and 51% of the failures reported on LERs were aging or aging related. This review supported the conclusion that aging has resulted in system and component degradations and failures. Due to the redundancy designed into the system, the majority of these failures did not impair the ability of the CVCS to provide the desired functions. However,

these failures do represent a loss of redundancy. Other operating events resulted in reactor coolant chemistry transients, and pressurizer level fluctuations.

A representative plant for each NSSS design was visited to obtain information on system inspection, surveillance, monitoring, and maintenance practices that mitigate aging. The effect of system aging on core damage frequency was also assessed.

9.1 Conclusions

The actual design of the PWR CVCS system varies between NSSS suppliers and individual plants. However, the specific functions of each are equivalent. Based upon the review of the operating databases and plant specific information, the following conclusions were reached.

- 1) With the exception of high pressure injection, emergency boration, RCP seal injection and containment isolation, the other functions of the CVCS are non-safety related. However, failures affecting the components necessary to provide these functions could result in significant plant effects, including loss of normal boration, RCS inventory control, RCS chemistry control, and boron recovery. These failures could lead to plant transients, and reactor scrams. Sufficient redundancy is provided for the key system components (charging pumps, deionizers, bypass valves) such that failure does not result in the loss of function. However, these failures do represent a loss of redundancy which could result in the system being unable to operate as designed if the redundant component also failed.
- 2) Degradation of the positive displacement pumps and isolation and control valves (gate and globe) accounted for the majority of the system failures. The majority of these failures resulted in coolant leakage resulting from packing and seal degradation. Packing degradation is a result of normal operation,

however, and if not detected in a timely fashion, could result in leakages outside of containment and increases in airborne gaseous activity.

- 3) In addition to valve degradation, valve operator (pneumatic and motor-operated) failures also accounted for a significant number of failure occurrences. The primary effect of these occurrences was a failure to operate properly (failure to open or close upon demand).
- 4) In order to provide for rapid reactivity control, a highly concentrated boric acid solution (20,000-22,000 ppm) is stored in the boric acid storage tank. To maintain the boric acid in solution, heaters are used both in the tanks and on the piping. Numerous operating difficulties have resulted from this storage. These include corrosion of carbon steel fasteners, boric acid precipitates forming from failure of the heaters, and tank level instrumentation failures from boric acid crystallization. Due to these difficulties, many utilities have reduced the required concentration of boric acid needed.
- 5) A review of the operating experience has shown that not every non-safety related component requires the same maintenance frequency. Significant benefits have been realized from the application of reliability centered maintenance. Each of the utilities visited has applied this method which resulted in improved allocation of maintenance and surveillance resources, and the elimination of unnecessary maintenance (e.g., replacement of diaphragms on all valves) which could have resulted in unnecessary component aging. Plant personnel must remain cognizant that decreasing the inspections and testing frequencies may result in different aging stressors and mechanisms (i.e., stand-by valves). Maintenance frequency should be assessed based upon the particular components

failure history. The relative recent application of RCM at nuclear plants should result in less component failure occurrences and increased availability.

- 6) The majority of the system inspections and tests are performed in accordance with ASME Section XI, Appendix J, and plant Technical Specifications. However, in response to frequent reactor coolant leakage occurrences (primarily due to packing failures and degradation), many plants have increased inspection of the pumps from quarterly to weekly.
- 7) The majority of the CVCS system functions are not safety-related, so the total system is not modelled in PRAs. However, the HPI subsystem, which uses many of the same components is. The potential effect of aging of system components also used for HPI on core damage frequency highlighted the importance of monitoring and detecting age degradation before failure. Human errors were found to be the major contributor to CDF, followed by MOV failure. A parametric study showed that a system aging increase by a factor of ten resulted in a factor of five increase in the system contribution to CDF.

9.2 Recommendations

Based upon the results of this Phase I aging study, and the results obtained from the plant visits, the following general recommendations are made. These recommendations are intended to highlight the important areas of the CVCS which have been susceptible to aging degradation and failures.

- 1) One way the reliability of the system may be improved is to decrease the potential of boric acid related failures. One alternative which may be considered by plants is to evaluate the potential for decreasing the concentration of boric acid required for reactivity control.

- 2) Pump packing degradation, resulting in reactor coolant leakage, continues to be a industry wide problem with positive displacement pumps. A detailed review of the industry experience (both nuclear and non-nuclear) may be beneficial, with particular emphasis applied to packing material, design, and inspection and surveillance frequency.

10. REFERENCES

1. Vora, J.P., "Nuclear Plant Aging Research (NPAR) Program Plan," NUREG-1144, Rev. 2, June 1991.
2. Fullwood, R., et. at., "Aging and Life Extension Assessment Program (ALEAP) Systems Level Plan," BNL Report A-3270-12-86, December 1986.
3. Meyer, L.C., "Nuclear Plant Aging Research on High Pressure Injection Systems," NUREG/CR-4967, August 1989.
4. Gunther, W., and Sullivan, K., "Aging Assessment of the Westinghouse PWR Control Rod Drive System," NUREG/CR-5555, BNL-NUREG-52232, March 1991.
5. Grove, E., and Gunther, W., "Aging Assessment of the Combustion Engineering and Babcock & Wilcox Control Rod Drives," NUREG/CR-5783, BNL-NUREG-52299, January 1993.
6. "Modern Power Station Practice, Volume J," British Electricity International, Pergamon Press, New York, 1992.
7. Final Safety Analysis Report, Wolf Creek, Docket No. 50-482, May 1989.
8. Final Safety Analysis Report, Shearon Harris, Docket No. 50-400, December 1981.
9. Final Safety Analysis Report, Beaver Valley, Docket No. 50-334, July 1989.
10. Final Safety Analysis Report, Trojan Docket No. 50-344, July 1989.
11. Final Safety Analysis Report, Prairie Island, Docket No. 50-306, May 1973.
12. Final Safety Analysis Report, Waterford 3, Docket No. 50-382, December 1991.
13. Final Safety Analysis Report, Davis-Besse, Docket No. 50-346, January 1986.
14. Final Safety Analysis Report, Wolf Creek, Docket No. 50-482, May 1989.
15. Final Safety Analysis Report, Beaver Valley, Docket No. 50-334, July 1985.
16. Final Safety Analysis Report, Waterford 3, Docket No. 50-382, December 1991.
17. Final Safety Analysis Report, Bellefonte 1&2, Dockets No. 50-438 and 439, July 1981.
18. American Society of Mechanical Engineers, Boiler and Pressure Vessel Code, Section XI - "Rules for Inservice Inspection of Nuclear Power Plant Components," 1989 edition.
19. Code of Federal Regulations Part 50 Appendix J.
20. "Standard Technical Specifications - Westinghouse Plants," NUREG-1431, September 1992.
21. "Standard Technical Specifications - Combustion Engineering Plants," NUREG-1432, September 1992.
22. "Standard Technical Specifications - Babcock and Wilcox Plants," NUREG-1430, September 1992.
23. Green, S.J., et. al, "Nuclear Power Plant Resource Book - Volume 1: PWR," Electric Power Research

- Institute, EPRI TR-100359 Volume 1 Special Report February 1992.
24. Bergmann, C.A., and Lamantia, L.A., "Valve Performance in PWR Chemical and Volume Control Systems," Electric Power Research Institute, EPRI NP-5796, June 1988.
 25. Rao, G.V., "Metallurgical Investigation of Cracking in the Boric Acid Piping at Prairie Island 1" Summary of Presentation to NRC, February 3, 1983, Docket No. 50-282.
 26. McConnell, T.L., Duke Power Company, letter to U.S. Nuclear Regulatory Commission, April 11, 1991, Docket 50-370.
 27. Goldberg, J.H., Houston Lighting & Power, letter to U.S. Nuclear Regulatory Commission, May 14, 1987, Docket No. 50-498.
 28. Russell, K.D., et. al., "Integrated Reliability and Risk Analysis System (IRRAS) Version 4.0," NUREG/CR-5813 Vol. 1, January 1992.
 29. Julius, J.A., "Analysis of Core Damage Frequency: Surry Unit 1 Internal Events," NUREG/CR-4550 Vol. 3 Rev. 1, April 1990.
 30. Ruger, C.J., and Luckas, W.J., Jr., "Technical Findings Related to Generic Issue 23: Reactor Coolant Pump Seal Failure," NUREG/CR-4948, BNL-NUREG-52144, March 1989.
 31. Higgins, J., et. al., "Operating Experience and Aging Assessment of Component Cooling Water Systems in Pressurized Water Reactors," NUREG/CR-5052, BNL-NUREG-52117, July 1988.
 32. Lofaro, R., et. al., "Aging Assessment of Component Cooling Water Systems in Pressurized Water Reactors," NUREG/CR-5693, BNL-NUREG-52283, June 1992.
 33. Lofaro, R., et. al., "The Effects of Age on Nuclear Power Plant Containment Cooling Systems," NUREG/CR-5939, BNL-NUREG-52345, March 1994.
 34. Lee, B.S., et. al., "The Effects of Aging on Boiling Water Reactor Core Isolation Cooling Systems," NUREG/CR-6087, BNL-NUREG-52390, published November 1994.

Appendix A

Westinghouse Chemical and Volume Control System Principal Component Data Summary

Appendix A

Westinghouse Chemical and Volume Control System - Principal
Component Data Summary

	4 Loop	3 Loop	2 Loop
Positive Displacement Pump			
Number	1-3	0-3	3
Design pressure, psig	3,200	3,000	3,000
Design temperature, F	250-300	250	200
Design flow, gpm	98	77	60.5
Design head, ft	5,800	2385	2,385
Material	Austenitic stainless steel	Austenitic stainless steel	Austenitic stainless steel
Cooling water, gpm	81	-	-
Maximum operating pressure, for reactor coolant system hydrotest purposes, psig			
Design code	3,125 ASME III - Class 2	3,125 ASME III - Class 2	3,125 ASME III - Class 2
Driver			
Type	Electric motor	Electric motor	Electric motor
RPM	1,775	1,775	
Speed ratio	7.88:1	7.88:1	
Power supply	200 hp, 480V, 3 ϕ , Non-Class IE	480V, 3 ϕ , Non-Class IE	
Seismic design	Category I	Category I	Category I
Centrifugal Charging Pumps			
Number	1-3	0-2-3	
Design pressure, psig	2,800	2,800	
Design temperature, F	300	300	
Design flow, gpm	150	150	
Design head, ft	5,800	5,800	
Material	Austenitic stainless steel	Austenitic stainless steel	N/A
Cooling water, gpm	55		
Design code	ASME III, Class 2	ASME III, Class 2	
Driver			
Type	Electric motor	Electric motor	
RPM	1,800	1,800	
Power supply	600 hp, 4,160 V, 3 ϕ Class IE	600 hp, 4,160 V, 3 ϕ Class IE	
Seismic design	Category I	Category I	

Appendix A (Cont'd)

	4 Loop	3 Loop	2 Loop
Boric Acid Transfer Pump			
Number	2	2 (Canned)	
Design pressure, psig	150	150	
Design temperature, F	250	250	
Design flow, gpm	75	75	
Design head, ft	235	235	
Material	Austenitic stainless steel	Austenitic stainless steel	
Design code	ASME III, Class 3	ASME III, Class 3	N/A
Driver			
Type	Electric motor	Electric motor	
RPM	3,450 - 3500	3,450	
Power supply	15.0 - 20.8hp, 460V, 3 ϕ , Class 1E	15 - 20.8 461V, 3 ϕ , Class 1E	
Seismic design	Category I	Category I	
Boron Injection Makeup Pump ¹			
Number	1-2		
Design pressure, psig	150		
Design temperature, F	250		
Design flow, gpm	80		
Design head, ft	250		
Material	Austenitic Stainless Steel		
Seismic design	Non-Category I	N/A	N/A
Chiller Pumps			
Number	2	2	
Design pressure, psig	150	150	
Design temperature, F	200	200	
Design flow, gpm	400	400	
Design head, ft	150	150	
Material	Carbon steel	Carbon steel	
Seismic design	Non-Category I	Non-Category I	Non-Category I

Appendix A (Cont'd)

	4 Loop	3 Loop	2 Loop
Regenerative Heat Exchanger Number	1	1	1
Heat transfer rate at design conditions, Btu/hr	10.35-11.0x10 ⁶	8.26-8.34x10 ⁶	5.46x10 ⁶
Design pressure, psig	<u>Shell Side</u> 2,485	<u>Shell Side</u> 2,485	<u>Shell Side</u> 2,485
Design temperature, F	650	650	650
Fluid	Borated reactor coolant	Borated reactor coolant	Borated reactor coolant
Material	Austenitic stainless steel	Austenitic stainless steel	Austenitic stainless steel
Design code	ASME III, Class 2	ASME III, Class 2	ASME III, Class 2
Seismic design	Category I	Category I	Category I
Flow, lb/hr	<u>Tube Side</u> 37,300	<u>Tube Side</u> 27,300	<u>Tube Side</u> 19,760
Inlet temperature, F	560	130	-
Outlet temperature, F	290	518	-
	<u>Shell Side</u> 29,826	<u>Shell Side</u> 29,826	<u>Shell Side</u> -
	544-554	544-554	-
	283-290	283-290	-
	2735-3,100	2735	2,735
	650	650	650
	Borated reactor coolant	Borated reactor coolant	Borated reactor coolant
	Austenitic stainless steel	Austenitic stainless steel	Austenitic stainless steel
	ASME III, Class 2	ASME III, Class 2	ASME III, Class 2
	Category I	Category I	Category I
	27,300	22,370	19,760
	130	130	-
	518	489-501	-

Appendix A (Cont'd)

	4 Loop	3 Loop	2 Loop
Letdown Heat Exchanger Number	1	1	1
Heat transfer rate at design conditions, Btu/hr	14.8-16.1x10 ⁶	15.8-16.1x10 ⁶	10.2x10 ⁶
Design pressure, psig	Shell Side 150	Shell Side 150	Shell Side 150
Design temperature, F	Tube Side 600	Tube Side 600	Tube Side 600
Design flow, lbm/hr	400	400	400
Fluid	59,600	28,820-59,600	19,760
Material	Borated reactor coolant Austenitic stainless steel	Borated reactor coolant Austenitic stainless steel	Borated reactor coolant Austenitic stainless steel
Design code	ASME III, Class 2	ASME III, Class 3	ASME III, Class 2
Seismic design	Category I	Category I	Category I
	Component cooling water Carbon steel	Component cooling water Carbon steel	Component cooling water Carbon steel

Appendix A (Cont'd)

	4 Loop	3 Loop	2 Loop
Excess Letdown Heat Exchanger Number	1	1	1
Heat transfer rate at design conditions, Btu/hr	4.61-5.2x10 ⁶		
Design pressure, psig	Shell Side 150	Shell Side 150	Shell Side 150
Design temperature, F	250	250	200
Design flow, lb/hr	115,000-129,000	83,000-129,000	-
Inlet temperature, F	95-105	100-105	-
Outlet temperature, F	135-145	139-145	-
Fluid	Component cooling water	Component cooling water	Component cooling water
Material	Carbon steel	Carbon steel	Carbon steel
Design code	ASME III, Class 3	ASME III, Class 3	ASME III, Class 3
Seismic design	Category I	Category I	Category I
	Tube Side 2,485	Tube Side 2,485	Tube Side 2,485
	650	650	650
	12,980-12,410	7,500-12,410	12,350
	553-560	547-557	-
	165-195	129-165	-
	Borated reactor coolant	Borated reactor coolant	Borated reactor coolant
	Austenitic stainless steel	Austenitic stainless steel	Austenitic stainless steel
	ASME III, Class 2	ASME III, Class 2	ASME III, Class 2
	Category I	Category I	Category I

Appendix A (Cont'd)

	4 Loop	3 Loop	2 Loop
Seal Water Heat Exchanger Number	1	1	1
Heat transfer rate at design conditions Btu/hr	2.0-2.49x10 ⁶	1.45-1.5x10 ⁶	1.69x10 ⁶
Design pressure, psig			
Design temperature, F			
Design flow, lb/hr			
Inlet temperature, F			
Outlet temperature, F			
Fluid	Component cooling water	Component cooling water	Component cooling water
Material	Carbon steel	Carbon steel	Carbon steel
Design code	ASME III, Class 3	ASME III, Class 3	ASME III, Class 3
Seismic design	Category I	Category I	Category I
	Shell Side 150 250 99,500-125,000 95-105 121	Shell Side 150 250 49,400-115,000 100-105 118-122	Shell Side 150 250 86,550
	Tube Side 150 250 48,400-160,600 143-156 115-127	Tube Side 150 250 42,000-64,075 138-141 115	Tube Side 150 250 -
	Borated reactor coolant Austenitic stainless steel	Borated reactor coolant Austenitic stainless steel	Borated reactor coolant Austenitic stainless steel
	ASME III, Class 2	ASME III, Class 2	ASME III, Class 2
	Category I	Category I	Category I

Appendix A (Cont'd)

	4 Loop	3 Loop	2 Loop
Moderating Heat Exchanger ¹ Number	1	1	
Heat transfer rate at design conditions, Btu/hr	2.0-2.49x10 ⁶	2.53-10 ⁶	
Design pressure, psig	300	300	300
Design temperature, F	Shell Side 200	Shell Side 200	Tube Side 200
Design flow, lb/hr	59,600	59,600	59,600
Design inlet temperature, boron storage mode, F	50	50	115
Design outlet temperature, boron storage mode, F	92.4	92.4	72.6
Inlet temperature, boron release mode, F	140	140	115
Outlet temperature, boron release mode, F	123.2	123.7	131.3
Material	Austenitic stainless steel ASME VIII Non-Category I	Austenitic stainless steel ASME VIII Non-Category I	Austenitic stainless steel ASME VIII Non-Category I
Design code			
Seismic design			N/A

Appendix A (Cont'd)

	4 Loop	3 Loop	2 Loop
Letdown Chiller Heat Exchanger ¹ Number	I	I	I
Heat transfer rate at design conditions, boron storage mode, Btu/hr	1.65x10 ⁶	1.65x10 ⁶	1.65x10 ⁶
Design pressure, psig	Shell Side 150	Shell Side 150	Tube Side 300
Design temperature, F	200	200	200
Design flow, boron storage mode, lb/hr	175,000	175,000	59,600
Design inlet temperature, boron storage mode, F	39	39	72.6
Design outlet temperature, boron storage mode, F	48.4	48.4	45
Flow, boron release mode, lb/hr	Shell Side 175,000	Shell Side 175,000	Tube Side 59,600
Inlet temperature, boron release mode, F	90	90	123.7
Outlet temperature, boron release mode, F	99.8	99.4	96.1
Material	Carbon steel	Carbon steel	Austenitic stainless steel
Design code	ASME VIII	ASME VIII	ASME VIII
Seismic design	Non-Category I	Non-Category I	Non-Category I
			N/A

Appendix A (Cont'd)

	4 Loop	3 Loop	2 Loop
Letdown Reheat Heat Exchanger ¹ Number Heat transfer rate at design conditions, Btu/hr	1 1.49x10 ⁶	1 1.49x10 ⁶	1 1.49x10 ⁶
Design pressure, psig	Shell Side 300	Shell Side 300	Tube Side 600
Design temperature, F	200	200	400
Design flow, lb/hr	59,600	59,600	44,700
Inlet temperature, F	115	115	280
Outlet temperature, F	140	140	246.7
Material	Austenitic stainless steel ASME VIII	Austenitic stainless steel ASME VIII, Class 2	Austenitic stainless steel ASME VIII, Class 2
Design code	Non-Category I	Non-Category I	Non-Category I
Seismic design	Non-Category I	Non-Category I	Non-Category I
Volume Control Tank Number	1	1	1
Volume, ft ³	400	300	220
Design pressure, psig	75	75	75
Design temperature, F	250	250	200
Material	Austenitic stainless steel ASME III, Class 2	Austenitic stainless steel ASME III, Class 2	Austenitic stainless steel ASME III, Class 2
Design code	Category I	Category I	Category I
Seismic design	Category I	Category I	Category I
Boric Acid Tanks Number	2	2	2
Capacity, usable, gal	24,000	36,000	5,000
Design pressure, psig	10	Atmospheric	Atmospheric
Design temperature, F	200	200	250
Material	Austenitic stainless steel ASME III, Class 3	Austenitic stainless steel ASME III, Class 3	Austenitic stainless steel ASME III, Class 3
Design code	Category I	Category I	Category I
Seismic design	Category I	Category I	Category I

Appendix A (Cont'd)

	4 Loop	3 Loop	2 Loop
Batching Tank Number Capacity, gal Design pressure, vessel steam jacket, psig Design temperature, F (steam jacket) Material Design code Seismic design	1 400-800 Atmospheric 150-400 Austenitic stainless steel ASME VIII Non-Category I	1-2 400-800 Atmospheric 250-300 Austenitic stainless steel (tank) ASME VIII Non-Category I	1 800 Atmospheric 250 Austenitic stainless steel ASME VIII Non-Category I
Chemical Mixing Tank Number Capacity, gal Design pressure, psig Design temperature, F Material Design code Seismic design	1 5 150 200 Austenitic stainless steel ASME VIII Non-Category I	1 5 150 200 Austenitic stainless steel ASME VIII Non-Category I	1 5 150 200 Austenitic stainless steel ASME VIII Non-Category I
Chiller Surge Tank Number Capacity, gal Design pressure Design temperature, F Material Design code Seismic design	1 500 Atmospheric 200 Carbon steel ASME VIII Non-Category I	1 500 Atmospheric 200 Carbon steel ASME VIII Non-Category I	N/A

Appendix A (Cont'd)

	4 Loop	3 Loop	2 Loop
Mixed Bed Demineralizers			
Number	2	2	2
Design pressure, psig	200-300	200-300	200
Design temperature, F	250	250	250
Design flow, gpm	120	120	80
Resin volume, each, ft ³	30	30	30
Material	Austenitic stainless steel	Austenitic stainless steel	Austenitic stainless steel
Design code	ASME VIII	ASME VIII	ASME VIII
Seismic design	Non-Category I	Non-Category I	Non-Category I
Cation Bed Demineralizers			
Number	1	1	1
Design pressure, psig	200-300	200-300	200
Design temperature, F	250	250	250
Design flow, gpm	72-120	60	40
Resin volume, each, ft ³	20-30	30	12
Material	Austenitic stainless steel	Austenitic stainless steel	Austenitic stainless steel
Design code	ASME VIII	ASME VIII	ASME VIII
Seismic design	Non-Category I	Non-Category I	Non-Category I
Thermal Regeneration Demineralizers			
Number	5	4	
Design pressure, psig	300	300	
Design temperature, F	250	250	
Design flow, gpm	250	120	
Resin volume, each, ft ³	74	74	
Material	Austenitic stainless steel	Austenitic stainless steel	
Design code	ASME VIII	ASME VIII	
Seismic design	Non-Category I	Non-Category I	N/A

Appendix A (Cont'd)

	4 Loop	3 Loop	2 Loop
<p>Reactor Coolant Filter</p> <p>Number Design pressure, psig Design temperature, F Design flow, gpm Particle retention Material, vessel Design code Seismic design</p>	<p>1 200-300 250 120-250 98% of 25 micron size Austenitic stainless steel ASME III, Class 2 Category I</p>	<p>1 200-300 250 150 98% of 25 micron size Austenitic stainless steel ASME III, Class 2 Category I</p>	<p>1 Austenitic stainless steel ASME III, Class 2 Category I</p>
<p>Seal Water Injection Filters</p> <p>Number Design pressure, psig Design temperature, F Design flow, gpm Particle retention Material vessel Design code Seismic design</p>	<p>2 2,735-3,100 200-250 80 98% of 25 micron size Austenitic stainless steel ASME III, Class 2 Category I</p>	<p>2 2,735 200 80 98% of 25 micron size Austenitic stainless steel ASME III, Class 2 Category I</p>	<p>2 Austenitic stainless steel ASME III, Class 2 Category I</p>
<p>Seal Water Return Filter</p> <p>Number Design pressure, psig Design temperature, F Design flow, gpm Particle retention Material vessel Design code Seismic design</p>	<p>1 200-300 250 150-250 98% of 25 micron size Austenitic stainless steel ASME III, Class 2 Category I</p>	<p>1 150-200 250 150-250 98% of 25 micron size Austenitic stainless steel ASME III, Class 2 Category I</p>	<p>1 Austenitic stainless steel ASME III, Class 2 Category I</p>

Appendix A (Cont'd)

	4 Loop	3 Loop	2 Loop
Boric Acid Filter Number	1	1-2	1
Design pressure, psig	200-300	150-200	
Design temperature, F	250	250	
Design flow, gpm	150-250	150-250	
Particle retention	98% of 25 micron size	98% of 25 micron size	
Material vessel	Austenitic stainless steel	Austenitic stainless steel	Austenitic stainless steel
Design code	ASME III, Class 3	ASME III, Class 3	ASME III, Class 2
Seismic design	Category I	Category I	Category I
Letdown Orifice Number	45 <u>gpm</u> 1 22,200	45 <u>gpm</u> 1 22,370	45 <u>gpm</u> 1 22,200
Design flow, lb/hr			
Differential pressure at design flow, psig	1,525-1,900	4,700-1,900	1,525
Design pressure, psig	2,485	2,485	2,485
Design temperature, F	650	650	650
Material	Austenitic stainless steel	Austenitic stainless steel	Austenitic stainless steel
Design code	ASME III, Class 2	ASME III, Class 2	ASME III, Class 2
Seismic design	Category I	Category I	Category I
Chiller Unit' Number	1	1	
Capacity, Btu/hr (ice tons)	2.3 x 10 ⁶ 138	1.66 x 10 ⁶ 400	N/A
Design code	MS	MS	
Seismic design	Non-Category I	Non-Category I	

Note:

1. These components are used in plants with Boron Thermal Regeneration Systems.

Appendix B

Combustion Engineering Chemical and Volume Control System Principal Component Data Summary

**Appendix B Combustion Engineering Chemical and Volume Control System
Principal Component Data Summary**

Component	Design Value
Positive Displacement Pump Number Design pressure, psig Design temperature, F Design flow, gpm Design head, ft Material Cooling water, gpm Maximum operating pressure, for reactor coolant system hydrotest purposes, psig Design code Driver Type RPM Speed ratio Power supply Seismic design	3 2,735 250 44 - Austenitic stainless steel - 3,025 ASME III - Class 2 Electric motor - - 100 hp, 3 ϕ , Class 1E Category I
Centrifugal Charging Pumps Number Design pressure, psig Design temperature, F Design flow, gpm Design head, ft Material Cooling water, gpm Design code Driver Type RPM Power supply Seismic Design	N/A, except for Maine Yankee 3 2,850 300 150 - Austenitic Stainless Steel Electric Motor 800 hp, 3 ϕ , Class 1E Category I
Boric Acid Transfer Pump Number Design pressure, psig Design temperature, F Design flow, gpm Design head, ft Material Design code Driver Type RPM Power supply Seismic design	2-3 150 250 143 231 Austenitic stainless steel ASME III, Class 2 Electric motor - 25 hp, 3 ϕ , 440 volts, Class 1E Category I

Appendix B (Cont'd.)

Component	Design Value	
Boron Injection Makeup Pump Number Design pressure, psig Design temperature, F Design flow, gpm Design head, ft Material Design code Seismic design	N/A	
Chiller Pumps Number Design pressure, psig Design temperature, F Design flow, gpm Design head, ft Material Design code Seismic design	N/A	
Regenerative Heat Exchanger Number Design pressure, psig Design temperature, F Fluid Material Design code Seismic design Design Flow, gpm Inlet temperature, F Outlet temperature, F	1 <u>Shell Side</u> 3,025 650 Borated reactor coolant Austenitic stainless steel ASME III, Class 2 Category I 132 120 393	 <u>Tube Side</u> 2,485 650 Borated reactor coolant Austenitic Stainless steel ASME III, Class 2 Category I 128 550 254

Appendix B (Cont'd.)

Component	Design Value	
Letdown Heat Exchanger Number Design pressure, psig Design temperature, F Design flow, gpm Fluid Material Design code Seismic design	1 <u>Shell Side</u> 150 250 1,200 Component cooling water Carbon steel ASME III, Class 3 Category I	 <u>Tube Side</u> 650 550 128 Borated reactor coolant Austenitic stainless steel ASME III, Class 2 Category I
Excess Letdown Heat Exchanger Number Heat transfer rate at design conditions, Btu/hr Design pressure, psig Design temperature, F Design flow, lb/hr Inlet temperature, F Outlet temperature, F Fluid Material Design code Seismic design	N/A	
Seal Injection Heat Exchanger Number Heat transfer rate at design conditions, Btu/hr Design pressure, psig Design temperature, F Design flow, lb/hr Inlet temperature, F Outlet temperature, F Fluid Material Design code	N/A Except Palo Verde 1 <u>Shell Side</u> 110 360 1740 lbm/hr - - Steam - Sat Carbon Steel ASME III, Class 3	 <u>Tube Side</u> 2735 200 30 - - Reactor Coolant Austenitic Stainless Steel ASME III, Class 2

Appendix B (Cont'd.)

Component	Design Value
Moderating Heat Exchanger Number Heat transfer rate at design conditions, Btu/hr Design pressure, psig Design temperature, F Design flow, lb/hr Design inlet temperature, boron storage mode, F Design outlet temperature, boron storage mode, F Inlet temperature, boron release mode, F Outlet temperature, boron release mode, F Material Design code Seismic design	N/A
Letdown Chiller Heat Exchanger Number Heat transfer rate at design conditions, boron storage mode, Btu/hr Design pressure, psig Design temperature, F Design flow, boron storage mode, lb/hr Design inlet temperature, boron storage mode, F Design outlet temperature, boron storage mode, F Flow, boron release mode, lb/hr Inlet temperature, boron release mode, F Outlet temperature, boron release mode, F Material Design code Seismic design	N/A

Appendix B (Cont'd.)

Component	Design Value
Letdown Reheat Heat Exchanger Number Heat transfer rate at design conditions, Btu/hr Design pressure, psig Design temperature, F Design flow, lb/hr Inlet temperature, F Outlet temperature, F Material Design code Seismic design	N/A
Volume Control Tank Number Volume, gal Design pressure, psig Design temperature, F Material Design code Seismic design	1 4,780 75 250 Austenitic stainless steel ASME III, Class C Category I
Boric Acid Tanks Number Capacity, usable, gal Design pressure, psig Design temperature, F Material Design code Seismic design	2 11,800 15 200 Austenitic stainless steel ASME III, Class C Category I
Batching Tank Number Capacity, gal Design pressure, vessel steam jacket, psig Design temperature, F Material Design code Seismic design	1 630 Atmospheric 200 Austenitic stainless steel ASME VII Non-Category I
Chemical Addition Tank Number Capacity, gal Design pressure, psig Design temperature, F Material Design code Seismic design	1 4 150 150 Austenitic stainless steel ASME VII Non-Category I

Appendix B (Cont'd.)

Component	Design Value
Chiller Surge Tank Number Capacity, gal Design pressure Design temperature, F Material Design code Seismic design	N/A
Mixed Bed Demineralizers Number Design pressure , psig Design temperature, F Design flow, gpm Resin volume, each, ft ³ Material Design code Seismic design	2 200 250 128 32 Austenitic stainless steel ASME III, Class 2 Category I
Deborating Demineralizers Number Design pressure , psig Design temperature, F Design flow, gpm Resin volume, ft ³ Material Design code Seismic design	1 200 250 120 32 Austenitic stainless steel ASME III, Class 2 Category I
Thermal Regeneration Demineralizers Number Design pressure, psig Design temperature, F Design flow, gpm Resin volume, ft ³ Material Design code Seismic design	N/A
Letdown (Purification) Filters Number Design pressure, psig Design temperature, F Design flow, gpm Particle retention Material, vessel Design code Seismic design	2 200 250 128 98% of 20 micron size Austenitic stainless steel ASME III, Class 2 Category I

Appendix B (Cont'd.)

Component	Design Value
Seal Water Injection Filters Number Design pressure, psig Design temperature, F Design flow, gpm Particle retention Material, vessel Design code Seismic design	N/A
Seal Water Return Filter Number Design pressure, psig Design temperature, F Design flow, gpm Particle retention Material, vessel Design code Seismic design	N/A
Boric Acid Filter Number Design pressure, psig Design temperature, F Design flow, gpm Particle retention Material, vessel Design code Seismic design	N/A
Letdown Orifice ² Number Design flow, gpm Differential pressure at design flow, psig Design pressure, psig Design temperature, F Material Design code Seismic design	3 - 2485 550 Austenitic Stainless Steel - Class I
Chiller Unit Number Capacity, Btu/hr (ice tons) Design code Seismic design	N/A

Notes:

1. Maine Yankee, the only CE 3 loop plant; has one positive displacement pump.
2. Palisades only.

Appendix C

**Babcock & Wilcox Makeup and Purification System
Principal Component Data Summary**

**Appendix C Babcock & Wilcox Makeup and Purification System
Principal Component Data Summary**

Component	Design Value
Positive Displacement Pump Number Design pressure, psig Design temperature, F Design flow, gpm Design head, ft Material Cooling water, gpm Maximum operating pressure, for reactor coolant system hydrotest purposes, psig Design code Driver Type RPM Speed ratio Power supply Seismic design	N/A
Centrifugal II Stage (Horizontal) Pumps, (Makeup Pumps) Number Design pressure, psig Design temperature, F Design flow, gpm Design head, ft Material Cooling water, gpm Design code Driver Type RPM Speed Ratio Power supply Seismic design	3 3,500 200 150-450 6,500 Austenitic stainless steel - ASME III, Class 2 Electric motor 1,800 3.14:1 1000 hp, 6,900 V, 3 ϕ Class 1E Category I
Boric Acid Pump Number Design pressure, psig Design temperature, F Design flow, gpm Design head, ft Material Design code Driver Type RPM Power Supply Seismic design	2 150 200 25 210 Austenitic stainless steel ASME III, Class 3 Electric motor - Class 1E Diesel backed/ Category I

Appendix C (Cont'd)

Component	Design Value	
Boron Injection Makeup Pump Number Design pressure, psig Design temperature, F Design flow, gpm Design head, ft Material Design code Seismic design	N/A	
Chiller Pumps Number Design pressure, psig Design temperature, F Design flow, gpm Design head, ft Material Design code Seismic design	N/A	
Letdown Coolers Number Heat transfer rate at design conditions, Btu/hr Design pressure, psig Design temperature, F Fluid Material Design code Seismic design Flow, lb/hr Inlet temperature, F Outlet temperature, F	2 23.9 x 10 ⁶ <u>Shell Side</u> 200 350 Component Cooling Water Austenitic stainless steel ASME III, Class 3 Category I <u>Shell Side</u> 300,500 - -	 <u>Tube Side</u> 2,500 600 Borated reactor coolant Austenitic stainless steel ASME III, Class 1 Category I <u>Tube Side</u> 49,830 570 120
Letdown Heat Exchanger Number Heat transfer rate at design conditions, Btu/hr Design pressure, psig Design flow, lbm/hr Fluid Material Design code Seismic design	N/A	

Appendix C (Cont'd)

Component	Design Value	
Excess Letdown Heat Exchanger Number Heat transfer rate at design conditions, Btu/hr Design pressure, psig Design temperature, F Design flow, lbm/hr Inlet temperature, F Outlet temperature, F Fluid Material Design code Seismic design	N/A	
RCP Seal Water Return Cooler Number Heat transfer rate at design conditions, Btu/hr Design pressure, psig Design temperature, F Design flow, lbm/hr Inlet temperature, F Outlet temperature, F Fluid Material Design code Seismic design	2 2.67 x 10 ⁶ <u>Shell Side</u> 200 200 158,000 - - Component cooling water Carbon steel ASME III, Class 3 Category I	<u>Tube Side</u> 150 200 55,800 145 120 Borated reactor coolant Austenitic stainless steel ASME III, Class 3 Category I
Moderating Heat Exchanger Number Heat transfer rate at design conditions, Btu/hr Design pressure, psig Design temperature, F Design flow, lbm/hr Design inlet temperature, F boron storage mode, F Design outlet temperature, boron storage mode, F Inlet temperature, boron release mode, F Outlet temperature, boron release mode, F Material Design code Seismic design	N/A	

Appendix C (Cont'd)

Component	Design Value
<p>Letdown Chiller Heat Exchanger</p> <p>Number</p> <p>Heat transfer rate at design conditions, boron storage mode, Btu/hr</p> <p>Design pressure, psig</p> <p>Design temperature, F</p> <p>Design flow, boron storage mode, lb/hr</p> <p>Design inlet temperature, F boron storage mode, F</p> <p>Design outlet temperature, boron storage mode, F</p> <p>Flow, boron release mode, lb/hr</p> <p>Inlet temperature, boron release mode, F</p> <p>Outlet temperature, boron release mode, F</p> <p>Material</p> <p>Design code</p> <p>Seismic design</p>	<p>N/A</p>
<p>Letdown Reheat Heat Exchanger</p> <p>Number</p> <p>Heat transfer rate at design conditions, Btu/hr</p> <p>Design pressure, psig</p> <p>Design temperature, F</p> <p>Design flow, lb/hr</p> <p>Inlet temperature, F</p> <p>Outlet temperature, F</p> <p>Material</p> <p>Design code</p> <p>Seismic design</p>	<p>N/A</p>
<p>Makeup Tank</p> <p>Number</p> <p>Volume, ft³</p> <p>Design pressure, vessel steam jacket, psig</p> <p>Design temperature</p> <p>Material</p> <p>Design code</p> <p>Seismic design</p>	<p>1</p> <p>1200</p> <p>100</p> <p>200</p> <p>Austenitic stainless steel</p> <p>ASME III, Class 2</p> <p>Category I</p>
<p>Concentrated Boric Acid Tank</p> <p>Number</p> <p>Volume, ft³</p> <p>Design pressure, psig</p> <p>Design temperature</p> <p>Material</p> <p>Design code</p> <p>Seismic design</p>	<p>1 per unit</p> <p>4,200</p> <p>Atmospheric</p> <p>200</p> <p>Austenitic stainless steel</p> <p>ASME III, Class 3</p> <p>Category I</p>

Appendix C (Cont'd)

Component	Design Value
Boric Acid Addition Tank Number Volume, ft ³ Design pressure, vessel steam jacket, psig Design temperature, F Material Design code Seismic design	1 2,500 Atmospheric 200 Austenitic stainless steel ASME III, Class 3 Category I
Caustic Mixing Tank Number Volume, ft ³ Design pressure, psig Design temperature, F Material Design code Seismic design	1 27 Atmospheric 200 Austenitic stainless steel ASME VII (Non-Code) Non-Category I
Mixed Bed Demineralizers Number Design pressure, psig Design temperature, F Design flow, gpm Resin volume, each, ft ³ Material Design code Seismic design	2 150 200 100 65 Austenitic stainless steel ASME III, Class 3 Category I
Cation Bed Demineralizers Number Design pressure, psig Design temperature, F Design flow, gpm Resin volume, ft ³ Material Design code Seismic design	1 150 200 100 65 Austenitic stainless steel ASME III, Class 3 Category I
Thermal Regeneration Demineralizers Number Design pressure, psig Design temperature, F Design flow, gpm Resin volume, ft ³ Material Design code Seismic design	N/A

Appendix C (Cont'd)

Component	Design Value
Prefilter Filter Number Design pressure, psig Design temperature, F Design flow, gpm Particle retention Material, vessel Design code Seismic design	1 150 200 200 98% of 5 micron size Austenitic stainless steel ASME III, Class 2 Category I
Purification Filter Number Design pressure, psig Design temperature, F Design flow, gpm Particle retention Material, vessel Design code Seismic design	2 150 200 200 98% of 5 micron size Austenitic stainless steel ASME III, Class 2 Category I
Seal Water Injection Filters Number Design pressure, psig Design temperature, F Design flow, gpm Particle retention Material, vessel Design code Seismic design	2 3,200 200 60 98% of 5 micron size Austenitic stainless steel ASME III, Class 2 Category I
Seal Water Return Filter Number Design pressure, psig Design temperature, F Design flow, gpm Particle retention Material, vessel Design code Seismic design	N/A
Boric Acid Filter Number Design pressure, psig Design temperature, F Design flow, gpm Particle retention Material, vessel Design code Seismic design	1 150 200 100 98% of 25 micron size Austenitic stainless steel ASME III, Class 2 Category I

Appendix C (Cont'd)

Component	Design Value
Letdown (Block) Orifice Number Design pressure, psig Design temperature, F Material Design code Seismic design	<u>50 gpm</u> 1 2,195 200 Austenitic stainless steel ASME III, Class 2 Category I
Chiller Unit Number Capacity, Btu/hr (ice tons) Design code Seismic design	N/A

Appendix D.

Core Damage Frequency for Sequences with HPI Failures Composite Tree

Appendix D (Cont'd)

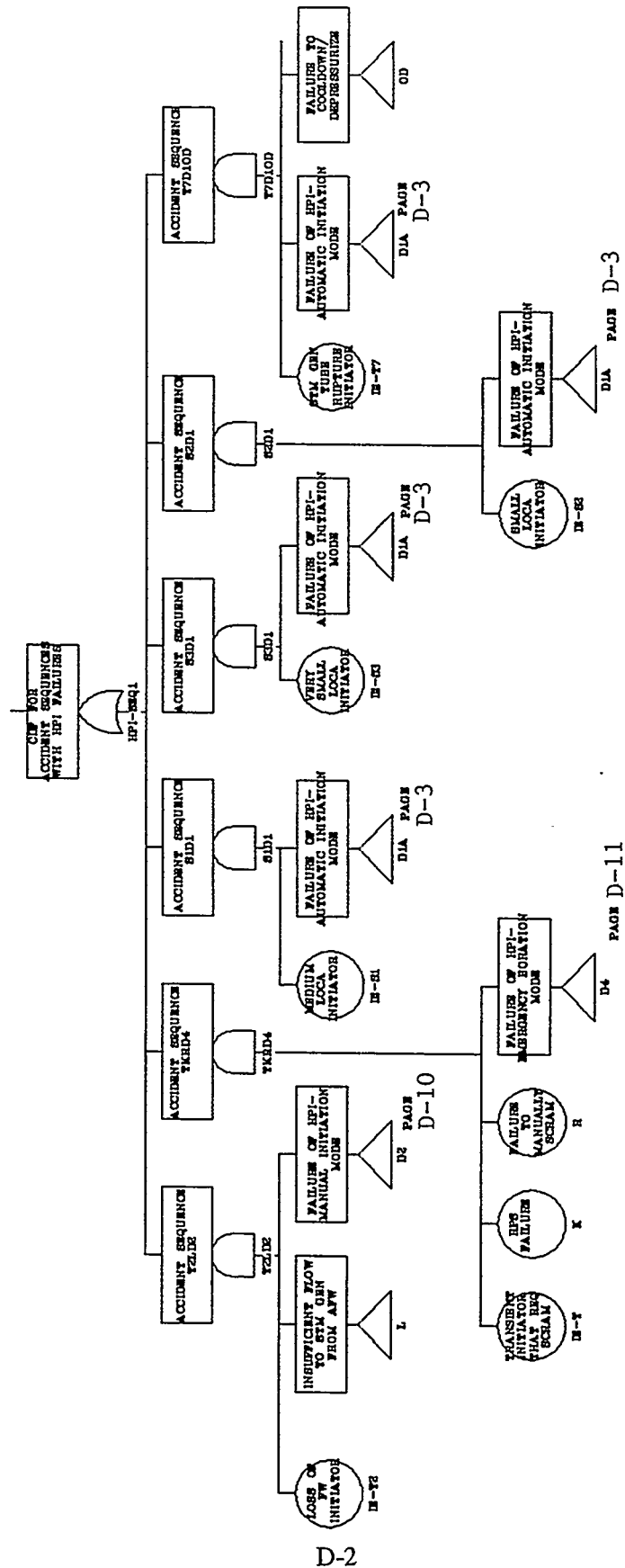

Appendix D (Cont'd)

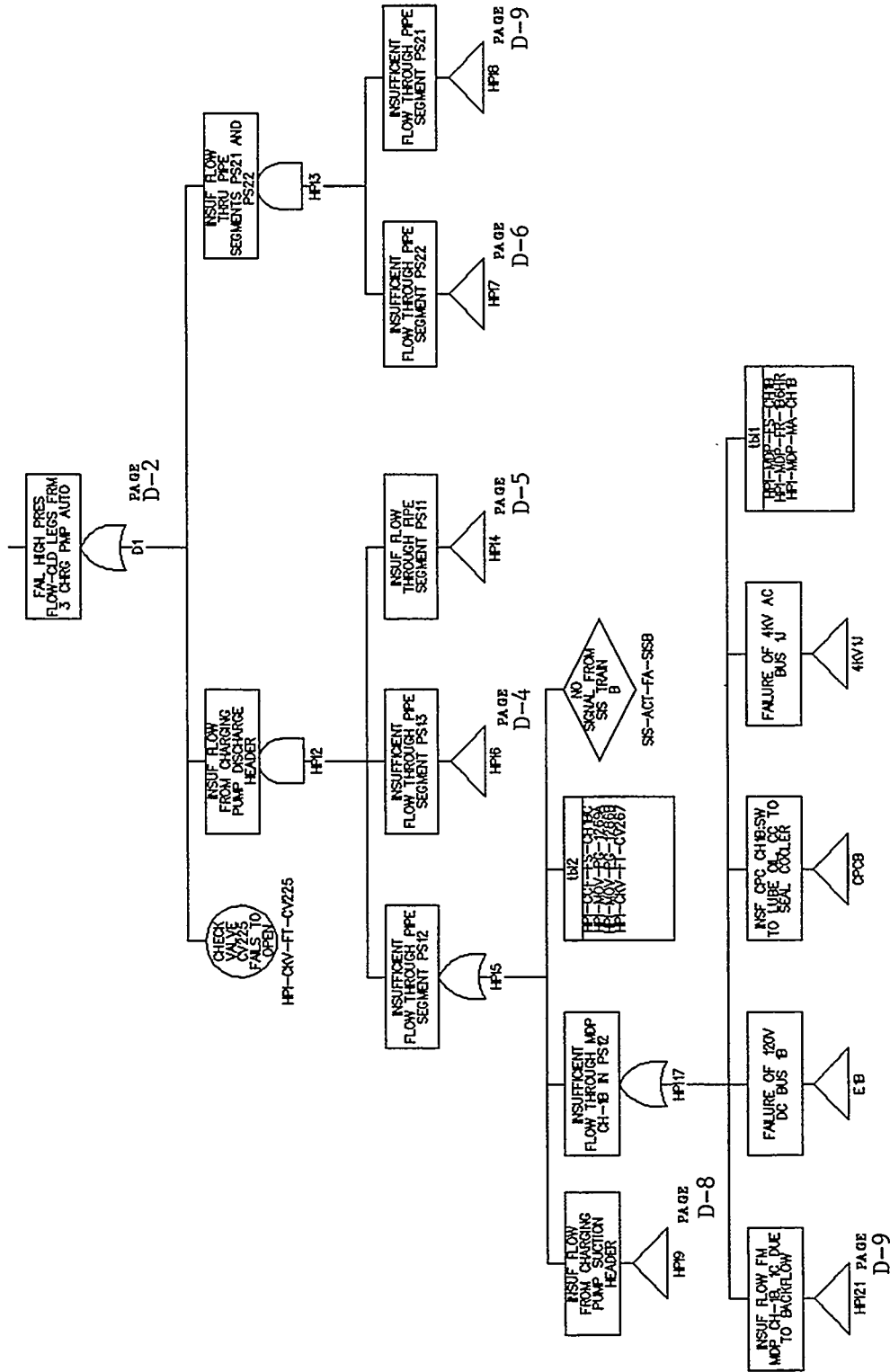

Appendix D (Cont'd)

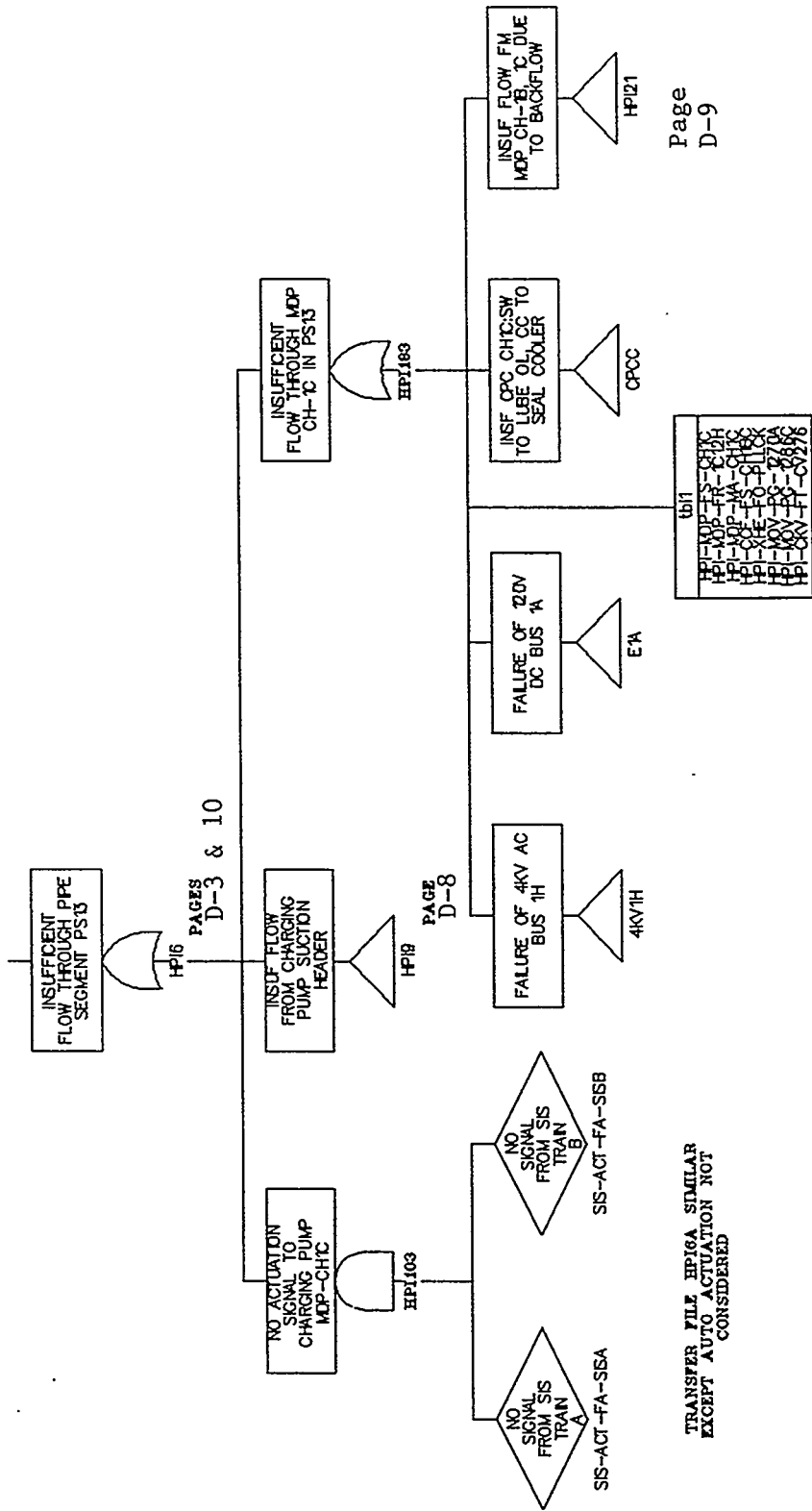

TRANSFER FILE HP16A SIMILAR EXCEPT AUTO ACTUATION NOT CONSIDERED

Appendix D (Cont'd)

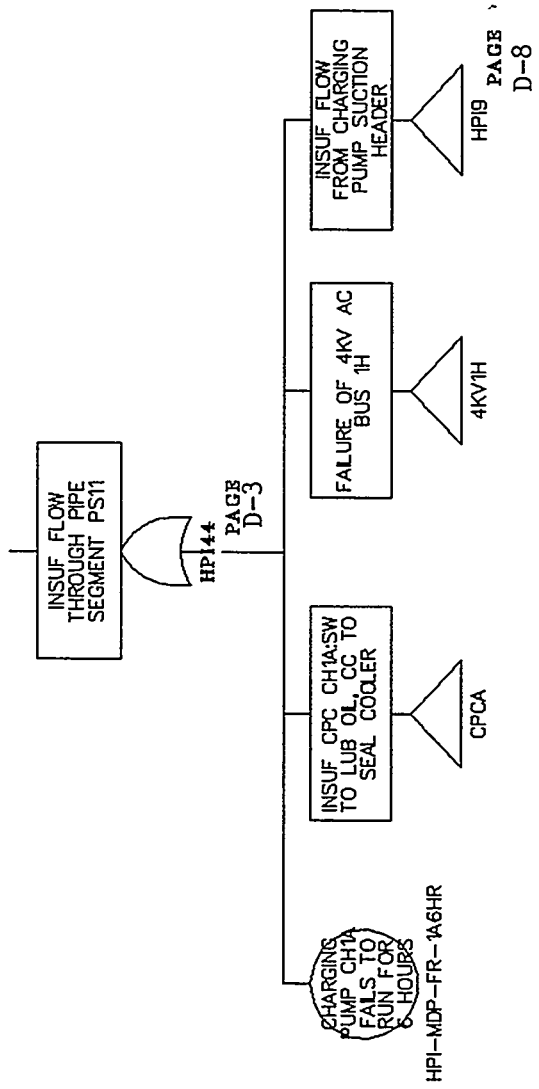

TRANSFER FILE HPI14A SIMILAR EXCEPT AUTO ACTUATION NOT CONSIDERED (TRANSFERS TO HPI6A INSTEAD OF HPI9)

Appendix D (Cont'd)

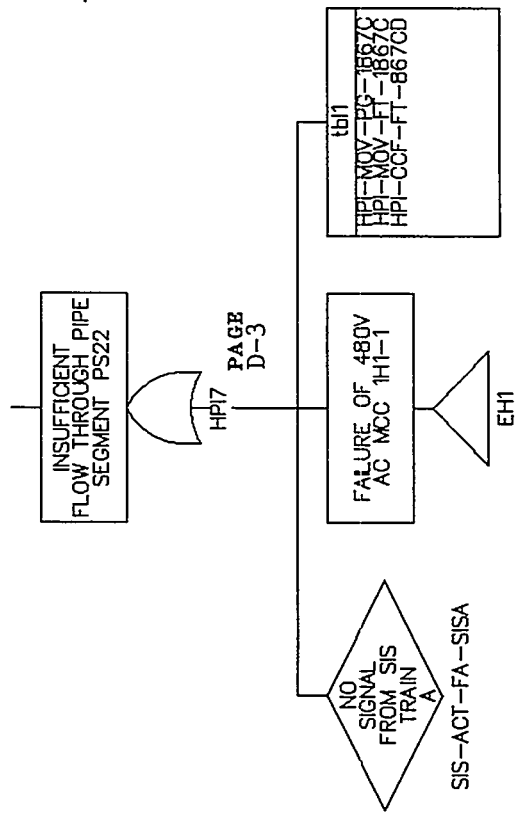

Appendix D (Cont'd)

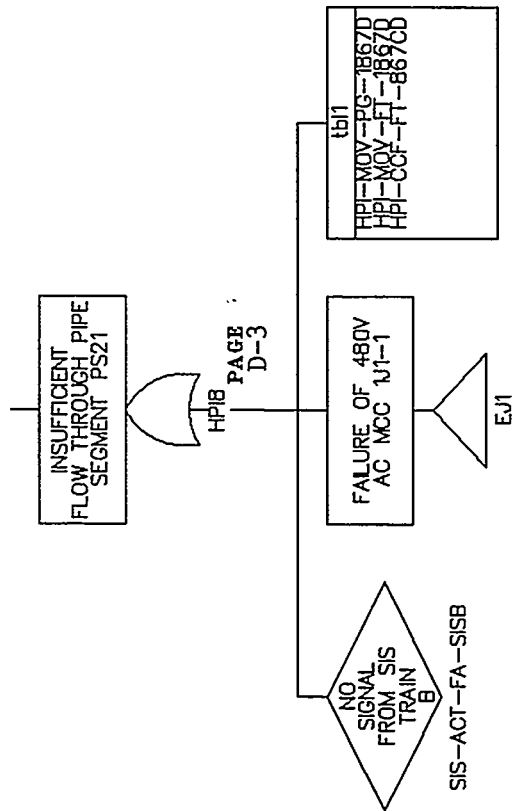

Appendix D (Cont'd)

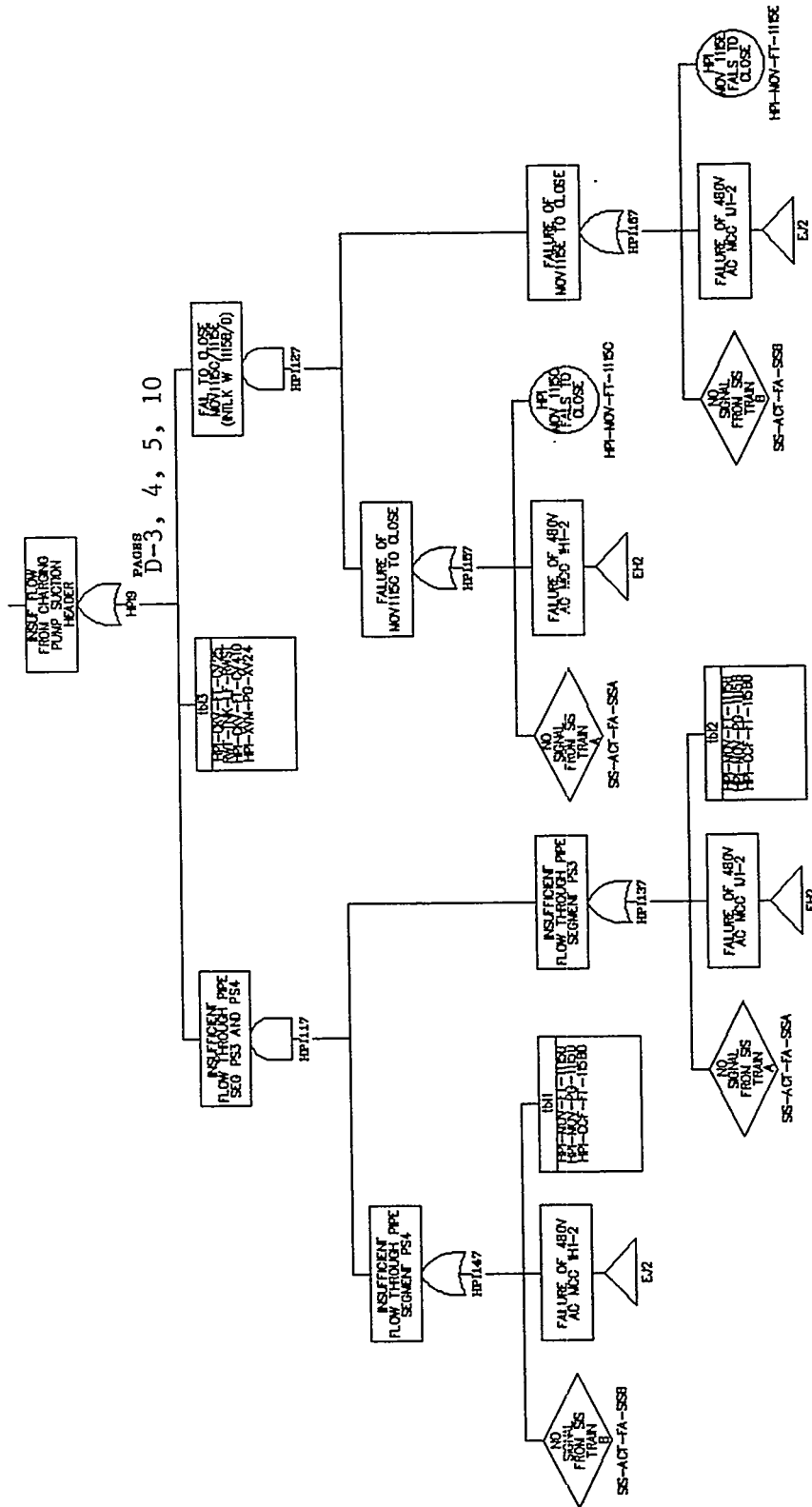

TRANSFER PUMP HP10A SIMILAR
EXCEPT AUTO ACTIVATION NOT
CONSIDERED

Appendix D (Cont'd)

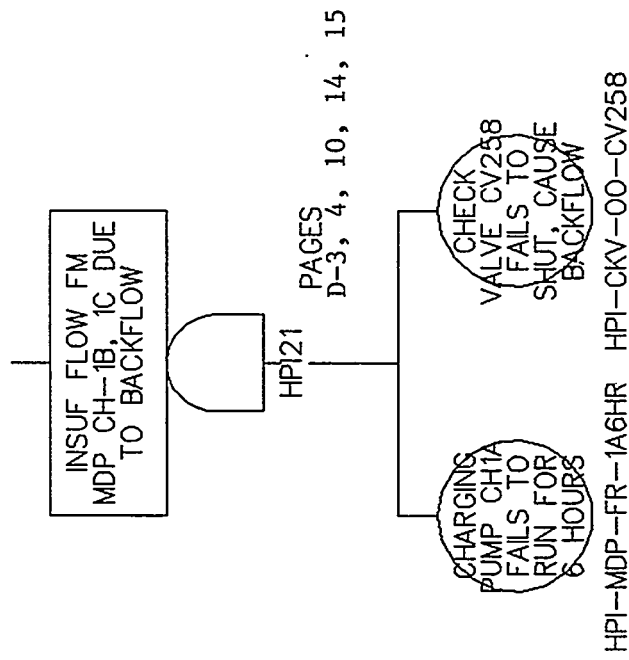

Appendix D (Cont'd)

EMERGENCY BORATION FAULT TREE

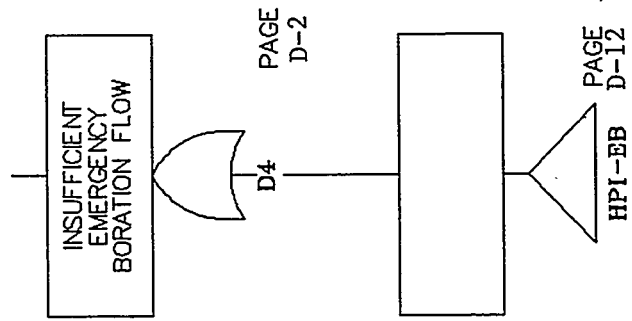

Appendix D (Cont'd)

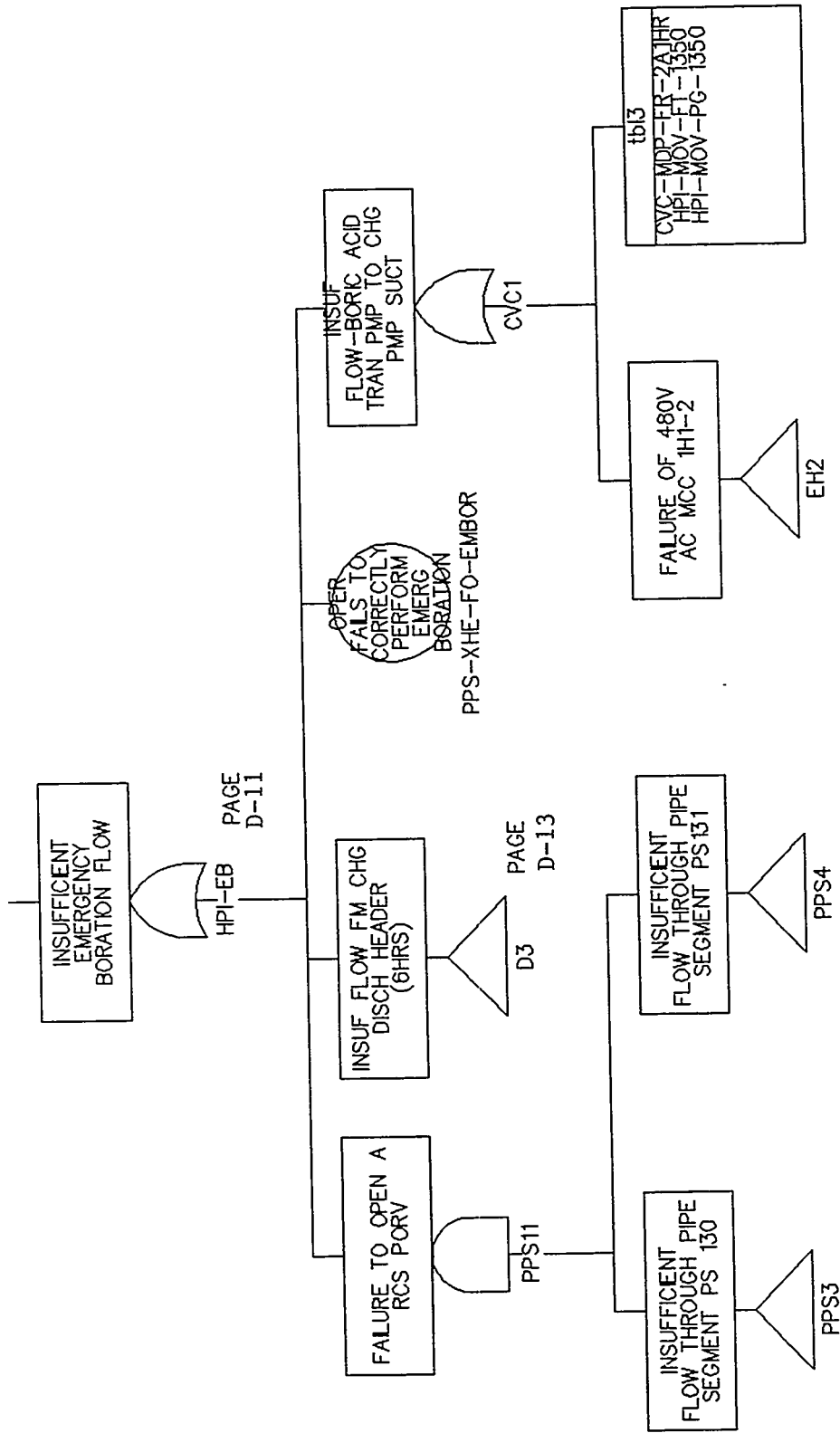

Appendix D (Cont'd)

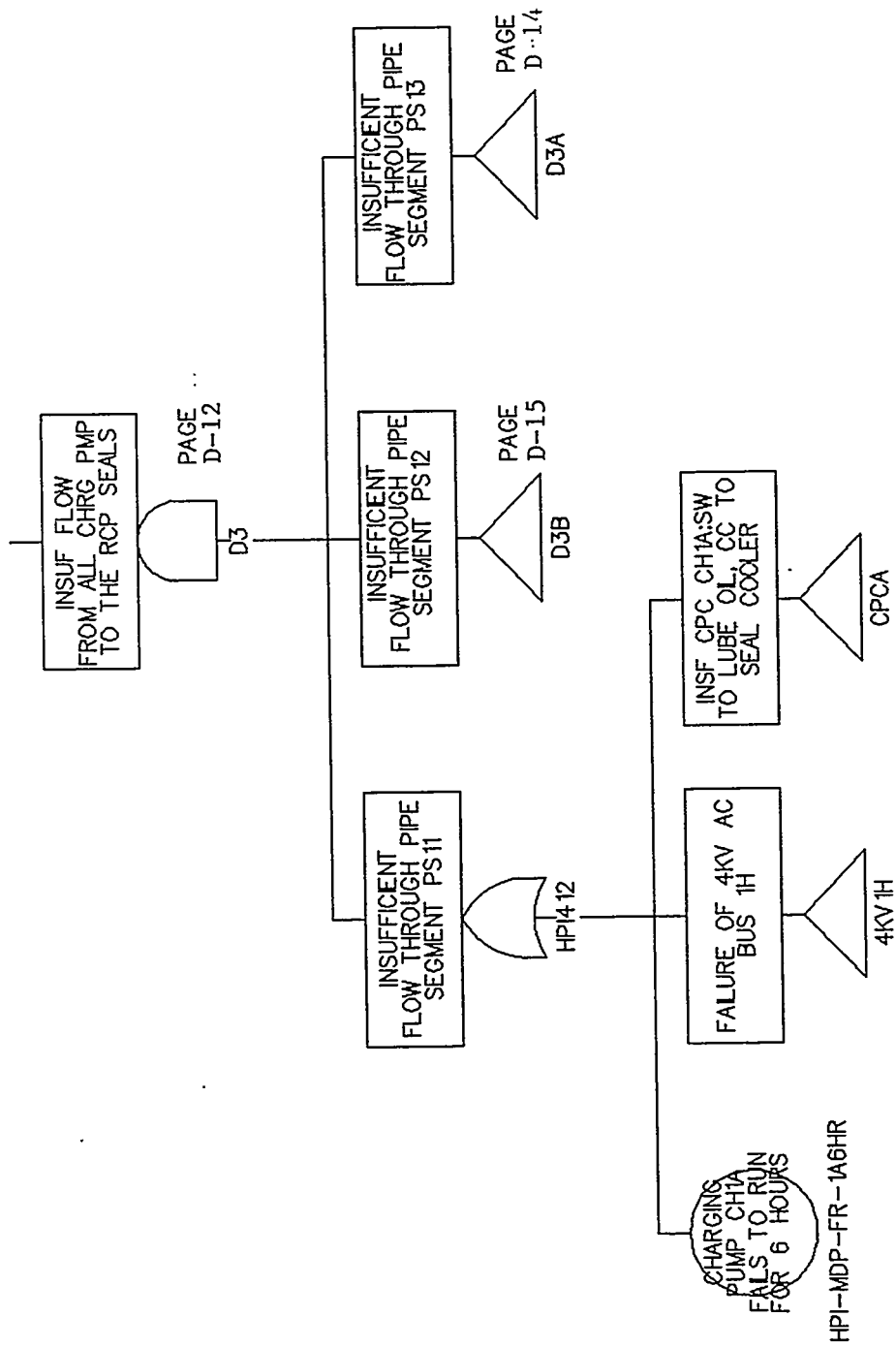

Appendix D (Cont'd)

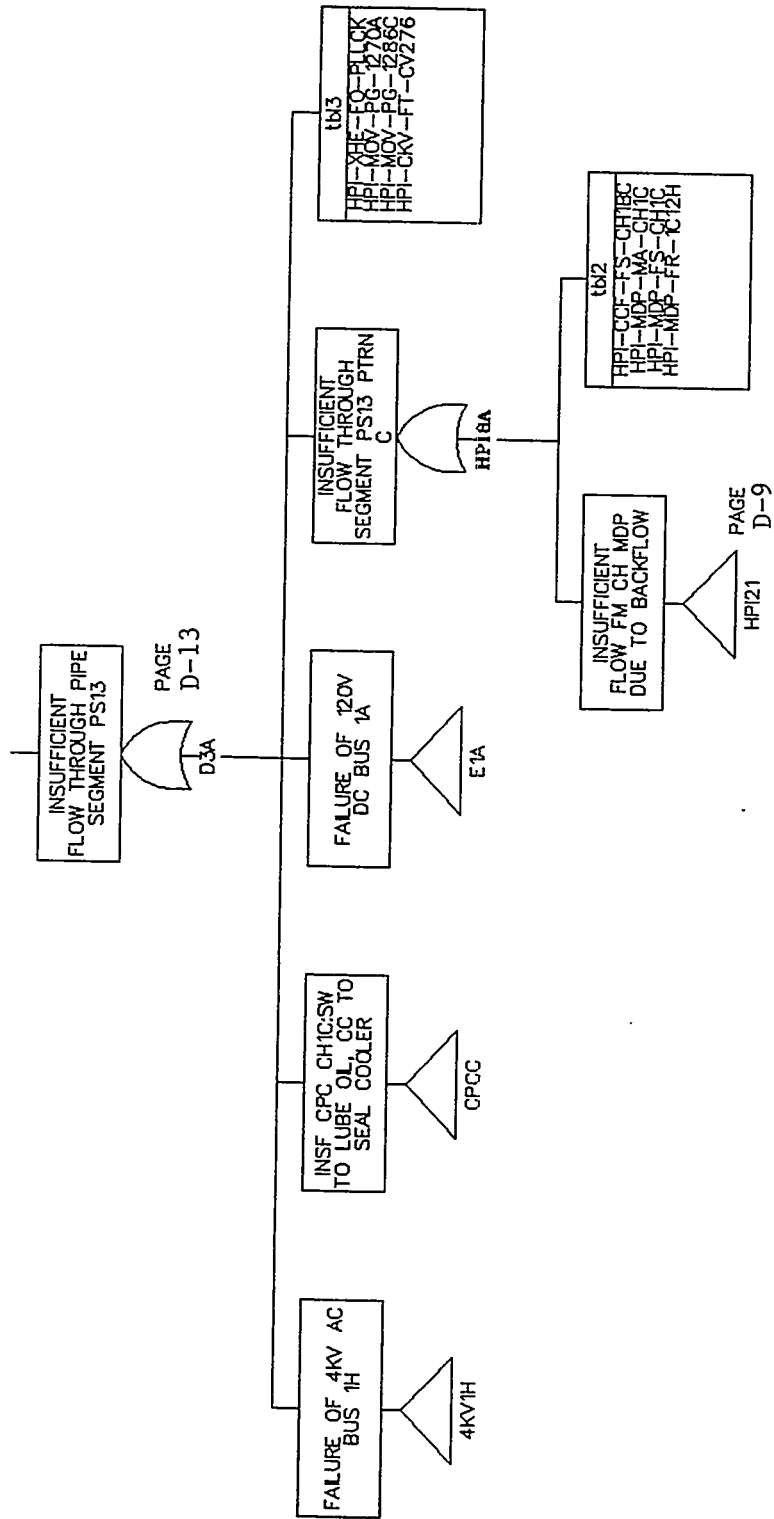

Appendix D (Cont'd)

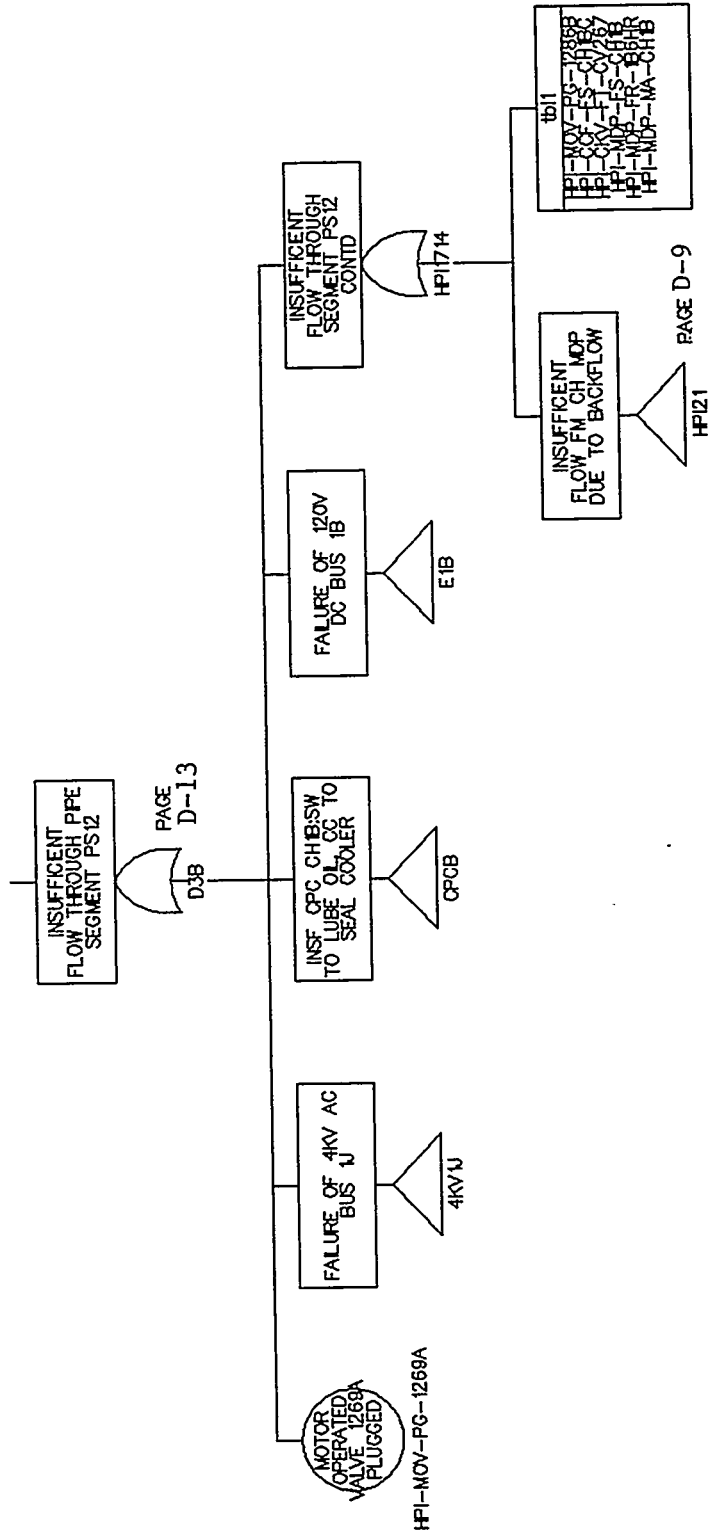

BIBLIOGRAPHIC DATA SHEET

(See instructions on the reverse)

1. REPORT NUMBER
(Assigned by NRC, Add Vol., Supp., Rev.,
and Addendum Numbers, if any.)

NUREG/CR-5954
BNL-NUREG-52410

2. TITLE AND SUBTITLE

Effect on Aging on PWR Chemical and Volume Control System

3. DATE REPORT PUBLISHED

MONTH | YEAR

June | 1995

4. FIN OR GRANT NUMBER

A3270

5. AUTHOR(S)

E.J. Grove, R.J. Travis

6. TYPE OF REPORT

7. PERIOD COVERED (Inclusive Dates)

8. PERFORMING ORGANIZATION -- NAME AND ADDRESS (If NRC, provide Division, Office or Region, U.S. Nuclear Regulatory Commission, and mailing address; if contractor, provide name and mailing address.)

Brookhaven National Laboratory
Upton, NY 11973-5000

9. SPONSORING ORGANIZATION -- NAME AND ADDRESS (If NRC, type "Same as above"; if contractor, provide NRC Division, Office or Region, U.S. Nuclear Regulatory Commission, and mailing address.)

Division of Engineering Technology
Office of Nuclear Regulatory Research
U.S. Nuclear Regulatory Commission
Washington, DC 20555-0001

10. SUPPLEMENTARY NOTES

11. ABSTRACT (200 words or less)

The effect of aging on the PWR Chemical and Volume Control System (CVCS) has been evaluated. A detailed review of the NPRDS and LER databases for the 1988-1991 time period, together with a review of industry and NRC experience and research, indicate that age-related degradations and failures have occurred. These failures had significant effects on plant operation, including reactivity excursions, and pressurizer level transients. The majority of these component failures resulted in leakage of reactor coolant outside the containment. A representative plant of each PWR NSSS design (W, CE, and B&S) was visited to obtain specific information on system inspection, surveillance, monitoring, and inspection practices. The results of these visits indicate that adequate system maintenance and inspection is being performed. In some instances, the frequencies of inspection were increased in response to repeated failure events. A parametric study was performed to assess the effect of system aging on Core Damage Frequency (CDF). This study showed that as MOV operating failures increased the contribution of the High Pressure Injection to CDF also increased.

12. KEY WORDS/DESCRIPTORS (List words or phrases that will assist researchers in locating the report.)

Coolant Cleanup Systems, Aging, Primary Coolant Circuits,
PWR Type Reactors, Reactor Cooling Systems, Accidents,
Decomposition, Excursions, Failures, Inspection, Loss of Coolant,
Maintenance, Operation, Reactor Core Disruption, System Failure
Analysis, Water Chemistry, Chemical and Volume Control System (CVCS),
Core Damage Frequency (CDF)

13. AVAILABILITY STATEMENT

Unlimited

14. SECURITY CLASSIFICATION

(This Page)

Unclassified

(This Report)

Unclassified

15. NUMBER OF PAGES

16. PRICE