

# **Sealing Large-Diameter Cast-Iron Pipe Joints Under Live Conditions**

**Quarterly Report  
March 25, 2004 – June 24, 2004**

***By:*  
Kiran M. Kothari  
(Gas Technology Institute)  
and  
Gerard T. Pittard  
(Maurer Technology Inc.)**

**July 2004**

**DE-FC22-02NT41316**

**GAS TECHNOLOGY INSTITUTE  
1700 South Mount Prospect Road  
Des Plaines, IL 60018-1804**

**MAURER TECHNOLOGY INCORPORATED  
13135 South Dairy Ashford, Suite 800  
Sugar Land, Texas 77478-3686**

# Disclaimer

This report was prepared as an account of work sponsored by an agency of the United States Government. Neither the United States Government nor any agency thereof, nor any of their employees, makes any warranty, express or implied, or assumes any legal liability or responsibility for the accuracy, completeness, or usefulness of any information, apparatus, product, or process disclosed, or represents that its use would not infringe privately owned rights. Reference herein to any specific commercial product, process, or service by trade name, trademark, manufacturer, or otherwise does not necessarily constitute or imply its endorsement, recommendation, or favoring by the United States Government or any agency thereof. The views and opinions expressed herein do not necessarily state or reflect those of the United States Government or any agency thereof.

# Abstract

Utilities in the U.S. operate over 75,000 km (47,000 miles) of old cast-iron pipes for gas distribution. The bell-and-spigot joints that connect pipe sections together tend to leak as these pipes age. Current repair practices are costly and highly disruptive. The objective of this program is to design, test and commercialize a robotic system capable of sealing multiple cast-iron bell and spigot joints from a single pipe entry point. The proposed system will perform repairs while the pipe remains in service by traveling through the pipe, cleaning each joint surface, and installing a stainless-steel sleeve lined with an epoxy-impregnated felt across the joint. This approach will save considerable time and labor, avoid traffic disruption, and eliminate any requirement to interrupt service to customers (which would result in enormous expense to utilities).

Technical challenges include: 1) repair sleeves must compensate for diametric variation and eccentricity of cast-iron pipes; 2) the assembly must travel long distances through pipes containing debris; 3) the pipe wall must be effectively cleaned in the immediate area of the joint to assure good bonding of the sleeve; and 4) an innovative bolt-on entry fitting is required to conduct repair operations on live mains.

The development effort is divided into eleven tasks. Task 1 (Program Management) and Task 2 (Establishment of Detailed Design Specifications) were completed in prior quarters while Task 3 (Design and Fabricate Ratcheting Stainless-Steel Repair Sleeves) has progressed to installing prototype sleeves in cast iron test pipe segments.

Efforts in this quarter continued to focus on Tasks 4 – 8, with significant progress made in each. Task 4 (Design, Fabricate and Test Patch Setting Robotic Train) progressed to the design of the control electronics and pneumatic system to inflate the bladder robotic patch setting module. Task 5 (Design & Fabricate Pipe-Wall Cleaning Robot Train with Pan/Zoom/Tilt Camera) continued with additional in-pipe testing required to optimize the design of the robot elements and surface control electronics and software.

Task 6 (Design & Build Surface Control and Monitoring System) has been completed with the control and computer display functions being operated through LabView. Task 7

(Design & Fabricate Large Diameter Live Access System) progressed to completing the detailed design of the entry fitting for 12-inch diameter cast iron pipe. The fitting is now being manufactured. The 12-inch ball valve for allowing no-blow access was also procured.

Task 8 (System Integration and Laboratory Validation) continued with the development of the robot module inter-connects and of a master LabView-based system display and control software.

# Table of Contents

<b>1. Introduction.....</b>	<b>1</b>
<b>2. Experimental .....</b>	<b>2</b>
Experimental Objectives.....	2
System Description .....	2
<b>3. Results and Discussion.....</b>	<b>5</b>
Task 1 – Program Management .....	5
Task 2 – Establishment of Detailed Design Specifications .....	5
Task 3 – Design and Fabricate Ratcheting Stainless-Steel Repair Sleeves.....	7
Task 4 – Design, Fabricate and Test Patch-Setting Robotic Train .....	14
Task 5 – Design & Fabricate Pipe Wall Cleaning Robot Train with PZT Camera .....	17
Task 6 – Design and Build Surface Control and Monitoring System.....	28
Task 7 – Design and Fabricate Large-Diameter Live Access System.....	28
Task 8 – System Integration and Laboratory Validation.....	33
Task 9 – Field Testing and System Refinement .....	34
Task 10 – Benefits Analysis .....	34
Task 11 – Final Report.....	34
Work Planned for Next Period.....	35
<b>4. Conclusions.....</b>	<b>36</b>
<b>5. References.....</b>	<b>37</b>

## List of Tables

Table 1.	Conventional Camera Wiring .....	19
Table 2.	Surface Power Supply Specifications .....	22

## List of Figures

Figure 1.	Pipe Wall Preparation Robot Train.....	2
Figure 2.	Camera’s View of Bell and Spigot Joint Seam.....	3
Figure 3.	Patch-Setting Robot Train.....	4
Figure 4.	Ratcheting Repair Sleeve .....	8
Figure 5.	Coiled Diameter Comparison for 28 and 24 Gauge.....	9
Figure 6.	Sleeve Ratcheting Design .....	9
Figure 7.	Repair Sleeve Components .....	10
Figure 8.	Repair Sleeve with Epoxy Applied.....	10
Figure 9.	12-Inch Cast Iron Pipe Sample .....	11
Figure 10.	Cast Iron Pipe ID after Cleaning.....	11
Figure 11.	Successfully Installed Repair Sleeve .....	12
Figure 12.	Inflation Bladder .....	13
Figure 13.	Ruptured Inflation Bladder .....	13
Figure 14.	Patch-Setting Module.....	15
Figure 15.	Patch Setting Test .....	16
Figure 16.	Locking Ratchets on Patch.....	16
Figure 17.	Pneumatic Inflation Circuit.....	17
Figure 18.	PZT Camera .....	18
Figure 19.	Camera Specifications .....	20
Figure 20.	Conventional Camera Control Cable Design.....	22
Figure 21.	Downhole Camera Control Circuit Schematic .....	24
Figure 22.	Downhole Camera Control Circuit Board .....	25
Figure 23.	PZT Camera Power Supply .....	26
Figure 24.	Camera Display and Control Software .....	26
Figure 25.	Pipe Wall Cleaning Element.....	27
Figure 26.	Pipe Wall Cleaning Test .....	28
Figure 27.	Cast Iron Entry Fitting (4-inch Prototype).....	30
Figure 28.	Cast Iron Entry Fitting (4-inch Prototype).....	30
Figure 29.	Cast Iron Entry Fitting (4-inch Prototype).....	30

Figure 30. Cast Iron Entry Fitting (4-inch Prototype).....31  
Figure 31. Entry Fitting for 12-inch Diameter Pipes.....31  
Figure 32. 12-Inch Entry Fitting.....32  
Figure 33. 12-Inch Entry Fitting Cutaway .....32  
Figure 34. Bi-Metal Hole Saw .....33

# 1. Introduction

Utilities in the U.S. operate over 75,000 km (47,000 miles) of old cast-iron pipes for gas distribution. Most of this pipe is in highly urbanized areas and its replacement is prohibitively expensive. While the cast-iron pipe itself generally retains acceptable mechanical competency, the joints, which are bell-and-spigot design, tend to leak. Current repair practices are to either: 1) excavate and expose each joint and encapsulate it externally; or 2) take the line out of service and apply repair sleeves or cured-in-place liners. Both methods are costly and highly disruptive.

The objective of this program is to design, test and commercialize a robotic system capable of sealing multiple cast-iron bell and spigot joints from a single pipe entry point. The proposed system will perform repairs while the pipe remains in service by traveling through the pipe, cleaning each joint surface, and attaching a stainless-steel sleeve lined with an epoxy-impregnated felt across the joint. This approach will save considerable time and labor, avoid traffic disruption, and eliminate the requirement to interrupt service, which results in enormous expense to utilities and considerable inconvenience to customers.

This development effort represents an aggressive expansion of existing technologies. Applying this technique inside large-diameter cast-iron pipes poses a number of technical challenges, among them: 1) the repair sleeves must compensate for diametric variation and eccentricity of cast-iron pipes; 2) the assembly must travel long distances through pipes having significant levels of debris; 3) the pipe wall must be effectively cleaned in the immediate area of the joint to assure good bonding of the sleeve; 4) an innovative bolt-on entry fitting is required to conduct repair operations on live mains; 5) coiled-tubing equipment must be designed to optimize push distance from a single pipe entry point.

## 2. Experimental

### Experimental Objectives

The objective of this development program is to design, test and commercialize a robotic system capable of sealing multiple cast-iron bell and spigot joints from a single pipe entry point. The proposed system will perform repairs while the pipe remains in service by traveling through the pipe, cleaning each joint surface, and attaching a stainless-steel sleeve lined with an epoxy-impregnated felt across the joint. This approach will save considerable time and labor, avoid traffic disruption, and eliminate any requirement to interrupt service to customers (which would result in enormous expense to utilities).

### System Description

The robotic joint-sealing system will be comprised of four main subsystems. These are: 1) two sequentially run, multiple-module robot trains; 2) pipe-access hardware for safely admitting into and removing the robot trains from the live gas-main environment; 3) a coiled-tubing (CT) delivery system for providing primary locomotion, power and data communications between the in-pipe robot and 4) surface control and display electronics.

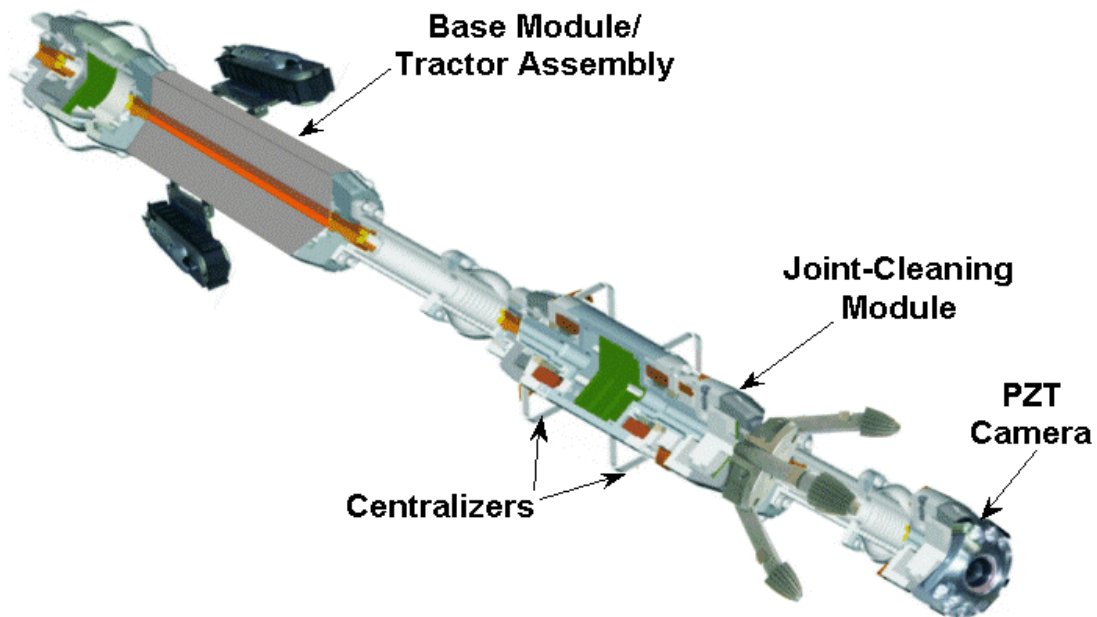

Figure 1. Pipe Wall Preparation Robot Train

Based on the analysis completed to date, two in-pipe robot trains will be required. The first robot train has a front-mounted camera that is used to visually locate each bell and spigot joint (**Figures 1 and 2**). Directly behind this camera is a counter-rotating brushing module whose function is to remove debris from the pipe wall within the cast-iron bell and spigot joint. This module may also have been fitted with a retractable plow to break down and level debris piles. The third and final module consists of a combination base/supplemental locomotion module. The base module provides all power and micro-controller control of the camera and brush modules. The supplemental locomotive will be used to provide additional axial movement forces as necessary.



Figure 2. Camera's View of Bell and Spigot Joint Seam

In operation, the camera/brush/base module train will be pushed by the CT to the farthest cast-iron bell and spigot joint to be repaired from a given launch location. The brushing module will then be activated to clean the joint by moving the brushing assembly back and forth across the joint location. Proper cleaning of this joint will be visually confirmed by the operator through the camera and may require one or more passes depending on the amount and tenacity of the debris coating the pipe wall. The CT unit is then used to withdraw the train back to the next joint where the cleaning process is repeated. This sequence is continued until all joints have been prepared for patching and the pipe-wall preparation train has been brought back into the pipe-access fitting and withdrawn from the main.

The brush module is then removed from the train and replaced with the stainless-steel patch-carrier/patch-setting module (**Figure 3**). The stainless-steel sleeve is slid over the carrier along with its polymer sleeve and polyester felt, which has been saturated with epoxy. The CT unit is then used to deliver the patch-setting train to the most distant bell and spigot joint. This location is confirmed both with the quadrature encoder footage counter and visually with the camera. Once the camera is located exactly at the bell and spigot-joint gap, the fine-resolution odometer on the camera is set to zero. The CT unit is then used in conjunction with the camera's odometer to move the patch setting train forward by a known, fixed distance which assures the

patch is properly aligned with the bell and spigot joint. A control command is then issued from the surface unit to the base unit to release nitrogen from a stainless-steel pressure vessel on-board the patch-setting module into its expandable rubber bladder. This causes the bladder to inflate and locks the stainless-steel sleeve into position via its interlocking, ratcheting barbs. The epoxy is allowed to cure and reaches full strength within 12 hours. During the interim, a gas-tight seal is assured by the polymer sleeve which has been energized against the joint by the hoop stress of the stainless-steel sleeve. (Note: The volume and rate at which the nitrogen is bled from the inflation bladder results in no appreciable dilution of the BTU quality of the natural gas.)

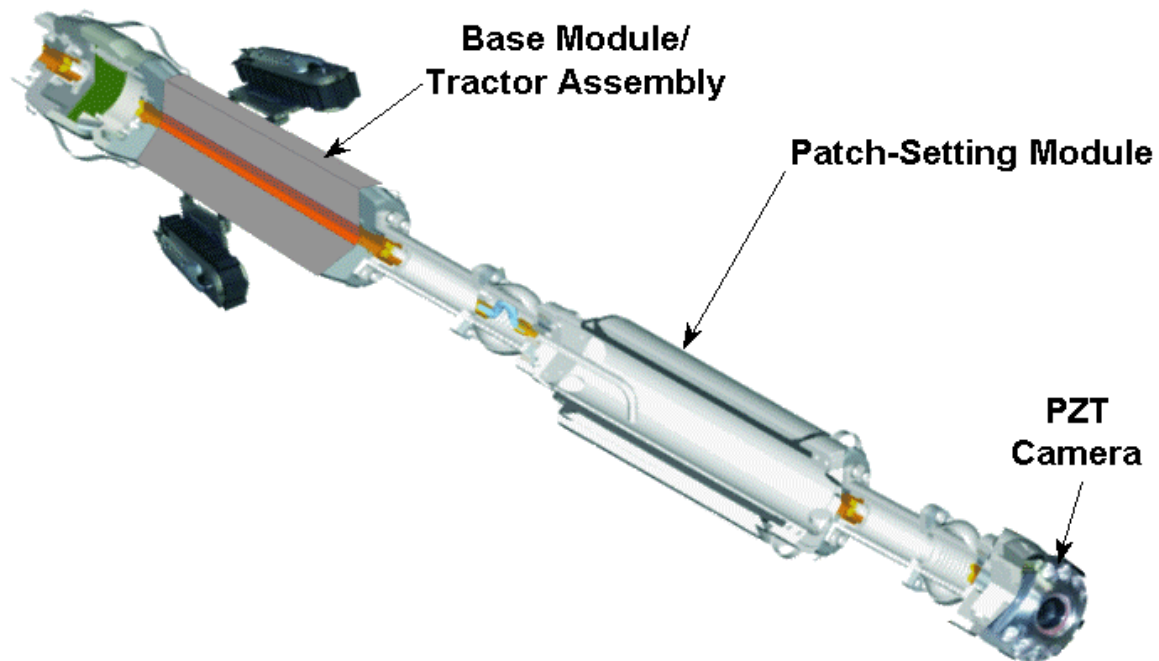

Figure 3. Patch-Setting Robot Train

### **3. Results and Discussion**

The project work structure consists of the 11 tasks described below. Work during the first eight quarters has focused on Tasks 1–8 and Task 10. Specific results and progress are described under each task. Work planned for the next quarter is discussed at the end of the chapter.

#### **Task 1 – Program Management**

A Research Management Plan, consisting of a summary of the program’s technical objectives and the technical approach for accomplishing these objectives was described and documented in a written report to DOE. The report was to include task descriptions, schedules and planned expenditures as well as major milestones and decision points.

In addition, a Technology Assessment was also prepared. The assessment was to establish the state-of-the-art of the technologies to be developed along with those technologies against which it must compete. The report describes each technology identifying both positive and negative aspects of using these technologies.

This task was completed in the first quarter.

#### **Task 2 – Establishment of Detailed Design Specifications**

The design of a system to inspect, prepare and patch cast-iron gas main joints under live conditions represents a substantial advancement over systems designed for small steel distribution lines. Key differences between small-diameter steel pipes and large-diameter cast-iron pipes should be identified and used to set benchmark design targets for hardware sizes and component functionality. The following subtasks support this benchmarking effort:

*2.1 Identify Mechanical, Material and Operational Differences between Small-Diameter Steel Mains and Large-Diameter Cast-Iron Mains.* The entry system for steel lines can be attached by welding (not an option with cast iron). This carries numerous concerns that must be addressed for the entry/access system, including means to fasten the entry fitting to the main, implementing a continuous

seal with long-term reliability, and designing an entry system that can tolerate settling of the joints over time and provide sufficient reinforcement of stiffness of the main both during and after the repair.

2.2 *Prototype Size Selection.* Large-diameter cast-iron gas mains in the U.S. range in size from 20 to 91 cm (8 to 36 in.) nominal diameter. Since there will obviously be size-specific requirements to be addressed, a size must be selected for the prototype system. This will be done through discussions with the GTI Distribution Task Group (DTG) Advisors. It is expected that the selected size will be either 20 cm (8 in.) or 30 cm (12 in.) since 30 cm and smaller sizes combined represent 95.5% of cast-iron mains in the US.

2.3 *Perform Pushing/Buckling Tradeoff Analyses.* Based on candidate coiled-tubing (CT) products, efforts will be aimed to define “sensitive” design targets points for hardware that will be inserted into the cast-iron main. These will include drag forces, weights of the components, bending requirements on the CT, and stiffness concerns for flexible joints between the required hardware modules on the robot train.

Deliverables for this task include a list of performance and size specifications that provide the basis for follow-on detailed design activities.

Mechanical, material and operational differences between small-diameter steel mains and large-diameter cast-iron mains have been defined. Primary challenges posed by large diameter cast-iron mains involve larger variation in inside pipe dimensions (being addressed by use of a ratcheting sleeve design that can effectively lock into placed over a range of pipe sizes); presence of more debris (being addressed through the use of much more aggressive wall cleaning equipment and the possible use of a plow to move debris away from the bell and spigot joint area); and the fact that the entry fitting for cast iron must be a bolt-on design and entry hole size should be minimized to prevent cracking of the brittle cast iron.

Discussions held with several utilities during the second quarter, including KeySpan Energy, Consolidated Edison and Public Service Electric & Gas, showed that utilities prefer the first prototype be sized for operations inside nominal 12-inch diameter cast-iron pipes. As a result, design efforts are focused on producing detailed designs for the entry fitting, cleaning

elements and repair sleeves for this size application. A prototype wall-cleaning device and a bolt-on entry fitting for 12-inch cast-iron have been designed.

The CT pushing/buckling analysis was completed in the first quarter. It is expected that this analysis will be briefly revisited after the final weights and drag loads on each robotic element are finished.

### **Task 3 – Design and Fabricate Ratcheting Stainless-Steel Repair Sleeves**

Existing repair sleeves are designed for application under “dead” main conditions (i.e., the mains are not in service and there is no internal pressure present). These sleeves cannot tolerate internal pressure. With current designs, a pressure gradient would displace the sealing epoxy prior to curing, thereby creating leak paths. In addition, repair sleeves for large cast-iron mains must be tolerant of misalignments in the bell and spigot joints. Such misalignment can prevent thorough sealing when using existing designs of repair sleeves.

The sleeve must conform tightly to the interior shape of the joint. A repair sleeve with ratcheting features will make this possible. Designs will be tested on cast-iron pipe samples (as available). Test sample joints will be specially fabricated with intentional misalignments to further test as necessary. To address these critical requirements, work efforts will be directed to:

- 3.1 *Determine Geometrical Spacing of Interlocking Barbs.* This spacing design must allow sufficient adjustment for misalignment of bell and spigot segments of the joints. Samples will be obtained to perform testing with misalignment conditions observed in the field.
- 3.2 *Perform Sensitivity Analyses.* Sealing design parameters must be evaluated with respect to sleeve geometry and the amount of compression (“squeeze”) on the patch during application. Patches must be able to lock into place while tolerating misalignment as well as lock in such a fashion to provide ample sealing over all required surfaces. Other aspects to be examined include the design thickness of the felt and the impact of this thickness on sealing effectiveness.

There will be two iterations of the interlocking sleeve design. The first design will be thoroughly tested and evaluated. After any augmentations are made to the first design, a second

set will be fabricated and evaluated. The deliverables for this task will be the final design of the ratcheting repair sleeves, complete with mechanical drawings and specifications for fabrication and assembly. A sufficient number (about eight) will be built following the second design iteration.

During the first quarter, the first design iteration for one type of the repair sleeves under consideration was prepared. This design is based on modifying existing sealing products from a commercial sleeve manufacturer (Link-Pipe Inc.) so that their sleeves can operate in pressurized gas mains, provide a redundant seal, and minimize their overall diameter before they are expansion-set across the bell and spigot joint. The current commercial sleeve design from the manufacturer does not work in pressurized mains and has only one seal method. In addition, the project approach is to minimize sleeve diameter for simplifying launching of the sleeve into the main and allowing it to ride off the bottom of the main (invert) to minimize its contamination with debris.

**Figure 4** illustrates the critical design features. A 28-gage, corrugated stainless-steel sleeve (316 SS) is used as the innermost member. Its function is to provide a mechanical means for energizing the urethane seal sleeve against the cast-iron wall to form the first leak seal and to allow the epoxy-saturated polyester carrier to cure to form a second (redundant) leak seal.

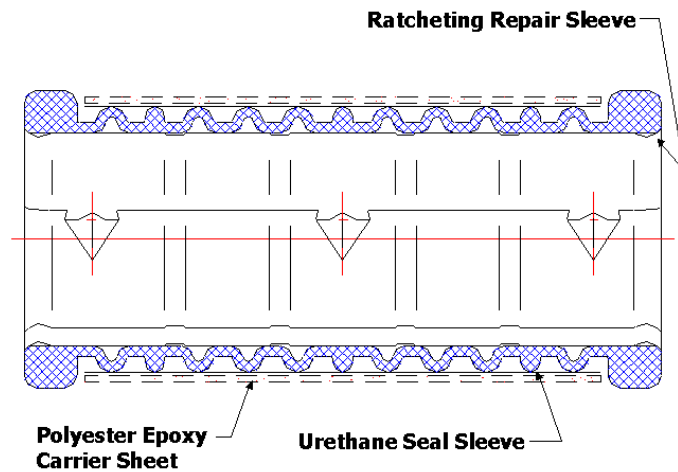

Figure 4. Ratcheting Repair Sleeve

The sleeve gage (28) is a reduction from the 24 gage normally used. Its use will enable the sleeve to be coiled in a smaller diameter without yielding. Preliminary analysis indicates that the design can be rolled into a diameter of about 55% of the pipe ID versus 75 % of the pipe ID for the 24-gage thickness sleeves (**Figure 5**). Corrugations, consisting of folds spaced on 1-inch centers, improve the structural stiffness of the device so it does not deform during setting.

The sleeve also features three rows of ratchets (**Figure 6**). The three rows allow the sleeve to be mechanically locked for diameter variations up to 0.50 inches.

The most obvious visual trait of the urethane seal sleeve is its grooves (ribs). This new design compensates for the axial shortening that would otherwise occur if a non-ribbed sleeve were allowed to radially expand significantly. The end elements feature increased thickness and act as an O-ring once the seal is expanded. Their thickness, coupled with low durometer, should provide an effective pressure seal across a range of cast-iron surface conditions as well as easily compensate for variation in pipe ID. AutoCAD machine drawings of the molds to produce these sleeves in both 8- and 12-inch sizes were prepared.



Figure 5. Coiled Diameter Comparison for 28 and 24 Gage

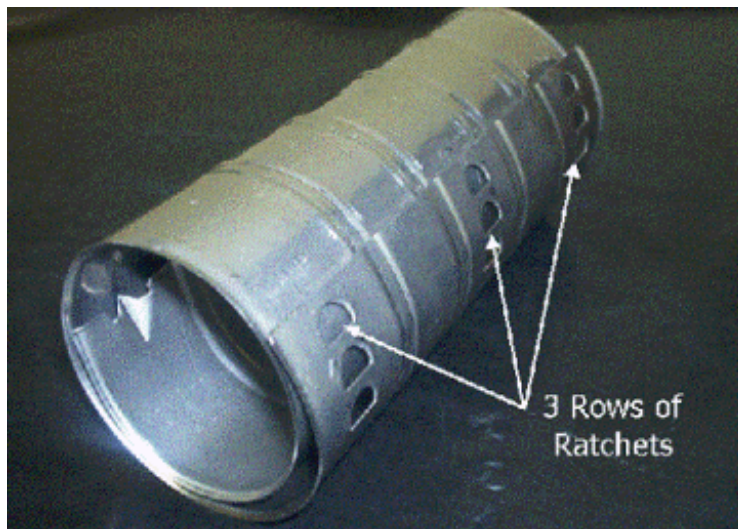

Figure 6. Sleeve Ratcheting Design

The final element of the design is a polyester jacket which will carry the epoxy resin. At present, a thixotropic epoxy is being considered that possesses about 1 hour of working time before curing begins to create the final seal.

Work in this quarter progressed to the fabrication and testing of the second-generation 12-inch repair sleeves featuring ratchets and polyurethane seal sleeves. Components of the most recent sleeve design are shown in **Figure 7**. The sleeve measures 13 inches long x 7.75 inches diameter in its collapsed (unset) state. **Figure 8** shows a sleeve with epoxy applied ready for insertion into the gas main via the inflation module.



Figure 7. Repair Sleeve Components



Figure 8. Repair Sleeve with Epoxy Applied

Several tests were recently conducted to set new 12-inch sleeves in the laboratory inside sample cast-iron joints (**Figure 9**). The first step was to use the cleaning module (see Figures 25 and 26 under Task 5) to clean debris and scale from the inside of the joint in preparation for running the sleeve (**Figure 10**).



Figure 9. 12-Inch Cast Iron Pipe Sample



Figure 10. Cast Iron Pipe ID after Cleaning

The sleeve was successfully set at a maximum inflation pressure of 30 psig (**Figure 11**). A few challenges yet remain for running and setting the patch (see below). However, pending further testing, this patch design is expected to represent the final design.



Figure 11. Successfully Installed Repair Sleeve

While setting new patches, it has become apparent that the existing material used in the inflation bladder (**Figure 12**) needs to be improved. The bladder was observed to fail after a limited number of inflation cycles along the line where the end of the inner sleeve contacts the gum rubber. Options for modifying the bladder include using another compound having a higher tensile strength, or further increasing the thickness of the gum rubber. **Figure 13** shows a failed gum rubber sleeve. Both alternatives for modifying the gum rubber sleeve are now being investigated.



Figure 12. Inflation Bladder



Figure 13. Ruptured Inflation Bladder

## **Task 4 – Design, Fabricate and Test Patch-Setting Robotic Train**

To set patches under live main conditions, the patching hardware must meet several key criteria. It must be able to be inserted and removed from the gas mains without damage. It must be able to be translated using coiled tubing (CT). Its physical form must not impede gas flow through the main (thereby maintaining gas delivery to customers). Lastly, it must be able to set patches with high reliability. To support the design, the following subtasks will be undertaken:

- 4.1 *Analyze Weight and Drag.* Hardware must be designed to perform required patch-setting functions while minimizing weight and drag, as these are key drivers in determining the push range and therefore the number of joints which can be repaired from each entry point.
- 4.2 *Analyze Reactive Force Limits.* The patch-setting equipment will be designed to effectively and reliably set patches while not exerting excessive reactive forces on the cast-iron pipe.
- 4.3 *Test Patch Integrity.* Testing will be conducted to verify that patches seat properly and to verify that sufficient epoxy comes into intimate contact with the cast-iron joint segments.
- 4.4 *Safety Testing.* Testing will be conducted throughout the design and testing phases to ensure that the hardware poses no safety risks to the operating gas main. All hardware elements that are operated in the main must not allow a leak path of gas to the surface. All elements will be purged and pressurized with N<sub>2</sub>. The differential pressure between the main and inside the hardware elements will be monitored to ensure that a positive differential is maintained. This same approach will be followed in the next task.

The deliverables for this task will be the Patch Setting Robotic Train along with its corresponding electrical/electronics schematics, mechanical drawings, and descriptive report documenting assembly, maintenance and operation.

Various patch-setting inflation modules have been designed, built and used to install the different generations of ratcheting repair sleeves. The latest sleeves are set by inflating the patch setting bladder to 30 psig which is held for a period of 5 minutes before deflation is allowed.

This provides sufficient time for the urethane sleeve to be compressed against the pipe wall and the ratchets to fully engage and lock

Setting tests have been successful, so efforts progressed to the design of the control electronics to operate the solenoid-controlled valve attached to a pressurized canister of nitrogen. **Figures 14-16** illustrate key aspects of the equipment. Unlike the other robotic elements, bypass of natural gas to prevent interruption of customer service occurs through the central pipe and not in the annular space between the robotic element outside diameter and the inside diameter of the cast-iron main.

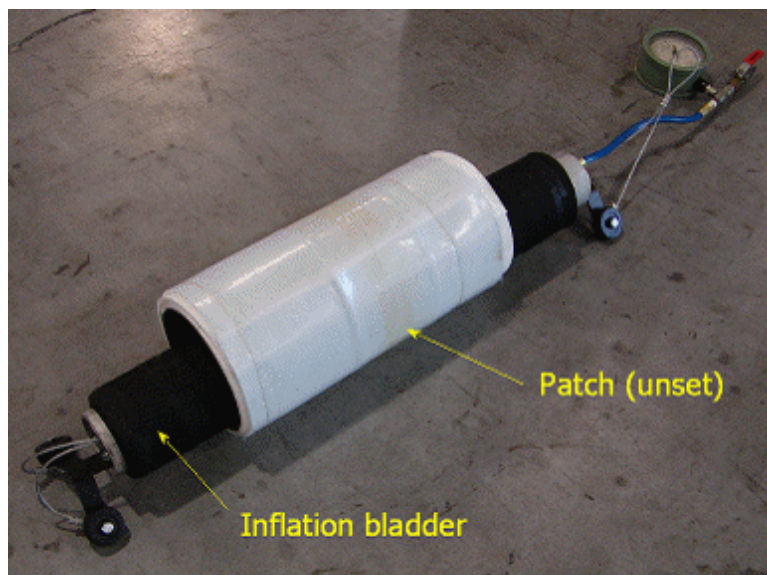

Figure 14. Patch-Setting Module

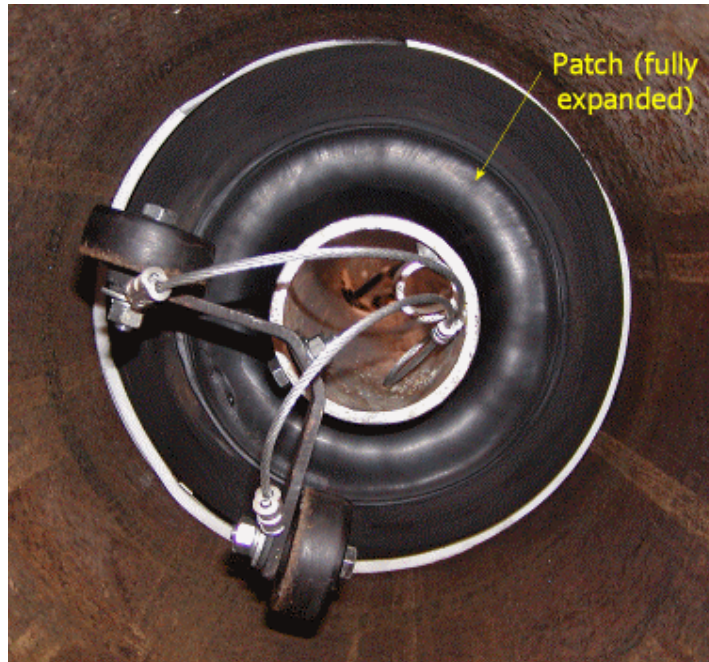

Figure 15. Patch Setting Test

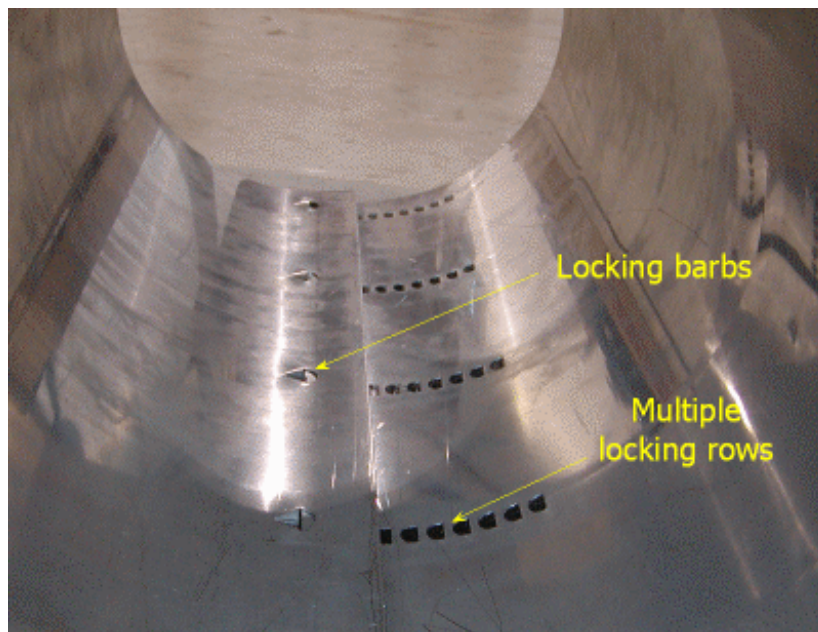

Figure 16. Locking Ratchets on Patch

The patch setting control system consists of a solenoid valve which allows the air pressure to be admitted into the inflation bladder under computer control, a pressure chamber for storing the nitrogen charge and pressure relief valves which allow adjustment of the charge pressure to compensate for differences in the gas main operating pressure. **Figure 17** summarizes the pneumatic inflation circuit.

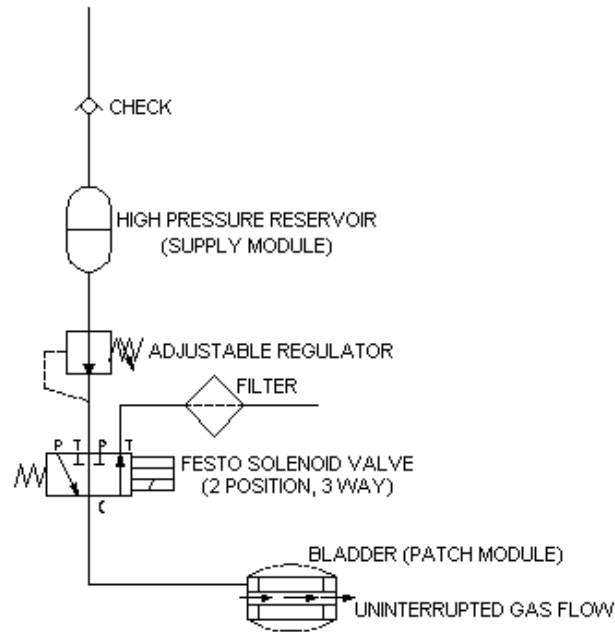

Figure 17. Pneumatic Inflation Circuit

## Task 5 – Design & Fabricate Pipe Wall Cleaning Robot Train with PZT Camera

Cast-iron gas mains operate at much lower pressure than their steel counterparts; consequently, their interior conditions are often quite different. Lower pressures in cast-iron mains can allow moisture and debris to seep in through leak points if sufficient hydrostatic head (from the local water table) is present outside of the main. In addition, the interior of cast iron is generally not as smooth as steel, due to corrosion and surface roughness from the original manufacturing process. Other complications arise due to deposits of tar residue in the bottom of the main. The source of this residue dates back to when mains carried “manufactured” gas. The molecularly heavier tars and other impurities settled out into the bottom of the mains and then combined with particulate matter to form a hard crust. This crust is porous and must therefore be removed prior to applying a patch repair sleeve. In addition, the pipe ID must be clean and smooth to ensure that the epoxy adheres properly to the cast iron. To address these challenges, the following subtasks are being completed in Task 5:

- 5.1 *Analyze Deposits and Scales.* The expected deposits in typical cast-iron mains will be investigated and the most effective way(s) to remove them will be defined.

5.2 *Design Equipment to Identify Deposit Types via Camera.* Design/select camera and lighting systems to provide sufficient performance to make positive identification and then select the appropriate means to prepare the surface.

5.3 *Design and Test Cleaning/Brushing Equipment.* Equipment will be designed to remove the scales and deposits found on the inside of cast-iron pipe. Tests will be conducted on line pipe to ensure that appropriate cleaning is performed by the system.

The deliverables for this task will be the Prototype Pipe Wall Cleaning Robot Train with Pan/Zoom/Tilt (PZT) Camera along with its corresponding electrical/electronics schematics, mechanical drawings, and descriptive report documenting assembly, maintenance and operation.

The analysis of different PZT cameras was completed in the second quarter and a preferred design selected. The camera measures 4 inches OD x 10.5 inches overall length as shown in **Figure 18**. It features 270° of tilt, 340° of pan and a 72:1 zoom ratio. It's eight, high intensity argon lights were found to provide excellent illumination in tests conducted inside sealed 12- and 24-inch pipes. Specifications are summarized in **Figure 19**. In normal operations where the camera tether is 100 feet or less, a 16-conductor bundle is used as defined in **Table 1**.

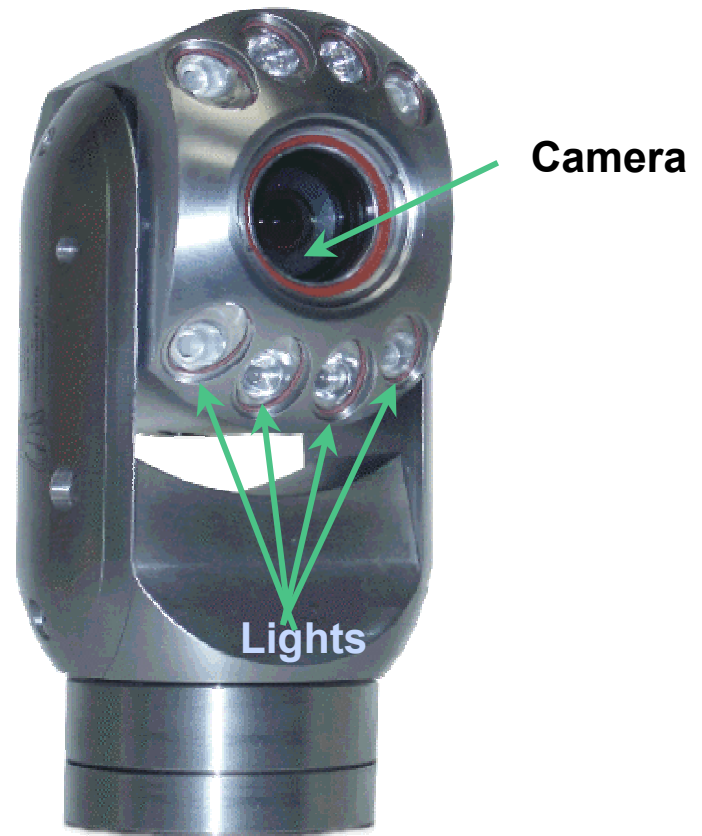

Figure 18. PZT Camera

**Table 1. Conventional Camera Wiring**

<b>ITEM</b>	<b>FUNCTION</b>
75 ohm coax	Video (+) core, Video (-) shield
18 awg, red	Camera Power (+)
18 awg, black	Camera Power (ground)
18 awg, yellow	Pan (+)
18 awg, orange	Pan (-)
18 awg, white	Tilt (+)
18 awg, blue	Tilt (-)
18 awg, pink and green	Camera Lights (+)
18 awg, purple and clear	Camera Lights (-)
22 awg, grey	Camera Function/Focus (+)
22 awg, black	Camera Function/ground
22 awg, tan	AF indicator/Focus (-)
22 awg, purple	2.5"/4.0" Indictaor
18 awg, brown	Camera Fade

# Pan/Zoom/Tilt (PZT) Camera

## SPECIFICATIONS

Pick-up Element: 1/4" CCD

Lens: 72:1 Zoom (18X Optical, 4X Digital)

Resolution: > 460 TV Lines

Illumination: 3 lux

Horizontal FOV: 48° wide 27° tele

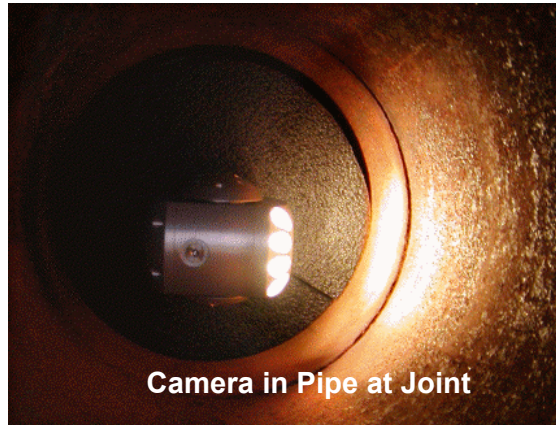

## Standard Camera Controller



Lights: 8 x 6 W Argon lights, variable intensity

Pan Range: 340° Mechanical, (360° Visible)

Tilt Range: > 270°

Power Requirements: 110/220 VAC

Pan/Tilt Control: Proportional

## Camera's View of Joint Seam



Figure 19. Camera Specifications

Use of a 16-conductor bundle becomes inefficient inside 1000 ft of small-diameter CT. A preferred approach is to power and operate the camera using seven wires. Two of these will be large-diameter twisted pair to supply high-voltage DC, four smaller wires to transmit digital control signals, and one to transmit video images. This change requires development of a microcontroller-operated switching power supply inside the robot base module and a data-acquisition system at the surface to convert the analog proportional joystick controls for pan, zoom, tilt, light intensity, etc. to digital signals.

During the third quarter, the robotic system's pan/zoom/tilt camera control electronics and operating software were developed and implemented in both the surface and downhole modules. Camera surface hardware consists of a 95-Volt DC power supply capable of sourcing up to 2.1 Amps for operating camera illumination, lenses and physical orientation within the pressurized gas main, a personal computer having an RS-485 bidirectional communications port, a 15-inch color monitor for displaying camera images and a rack-mounted video cassette recorder. Downhole hardware consists of the camera head and the camera control electronics. The latter is housed inside the robotics base module that is common for all robotic trains.

DC power is supplied to the downhole camera control electronics over an 18-gage twisted pair of conductors. Use of a single high-voltage power source at the surface was chosen over individually supplying all of the regulated voltages needed to operate the camera for two important reasons: 1) it is a highly efficient means of transferring electrical power down the long cables residing inside the steel coiled tubing and 2) it minimizes the total number of conductors required for the umbilical. The current design employs a total of seven wires to operate the camera. These include two wires for electrical power, four wires for the RS-485 digital communications link and one micro-coax for the video signal. This compares with a total of 15 wires that would be needed to operate the camera using a conventional analog circuit design such as shown in **Figure 20**.

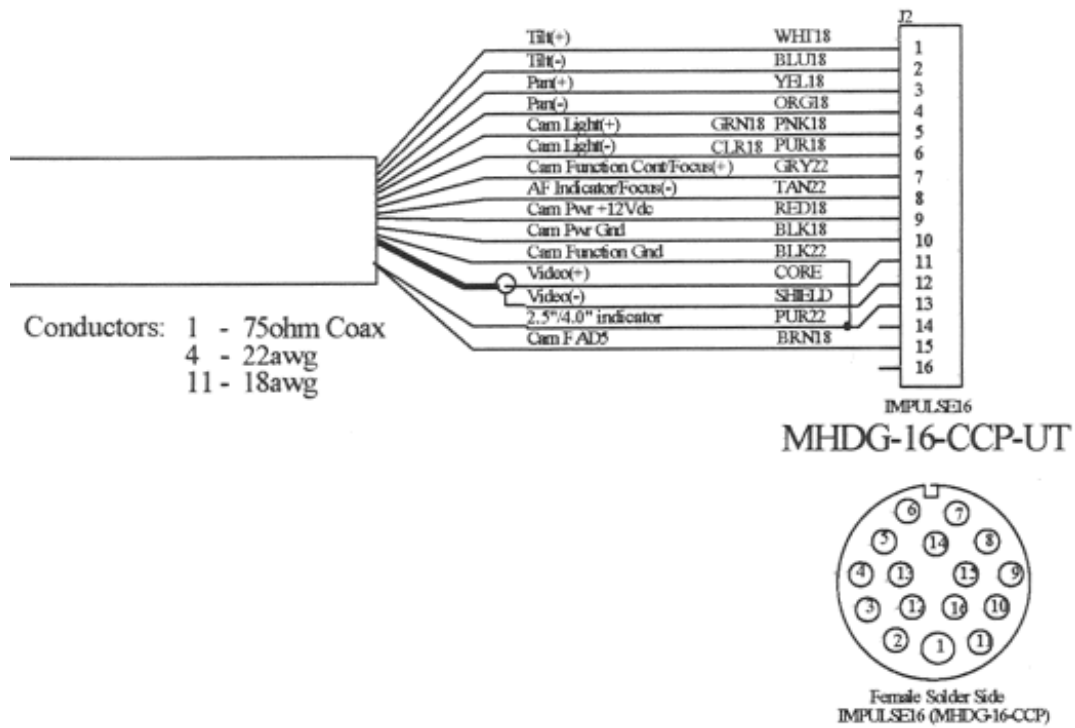

Figure 20. Conventional Camera Control Cable Design

**Table 2** summarizes key attributes of the surface DC power supply and two of the downhole DC/DC voltage conversions.

**Table 2. Surface Power Supply Specifications**

Manufacturer – Vicor		
95 V	2.1 A	200 W
12 V	4.2 A	50 W
7.5 V	6.7 A	50 W

Camera controls are displayed and operated using a software applications program written inside the LabView environment. The program allows the user to control the following functions through a point and click format:

- Camera Power (On/Off)
- Camera Illumination (Lights On/Off, Lights Dim/Bright)
- Camera Pan (0-340°)

- Camera Tilt (0-270°)
- Camera Zoom (18X optical; 4X digital)
- Camera focus

The LabView platform features excellent visual appeal through its virtual instrument displays, can be easily reconfigured and expanded to add new control capability as each new robot module is brought on line, and has excellent digital and analog support libraries. The user-selected commands are digitized and then communicated to the downhole camera control electronics via the RS-485 communications link. The RS-485 design and protocols were selected on the basis of their ease of implementation, low cost, and its demonstrated ability to support reliable communications over conductors up to 4000 ft in length, well in excess of the 1000-ft span required for this effort. A 20-MHz PIC micro-controller receives the RS-485 messages and actuates the commands accordingly. The electrical schematic for the downhole camera control electronics is shown in **Figure 21**.

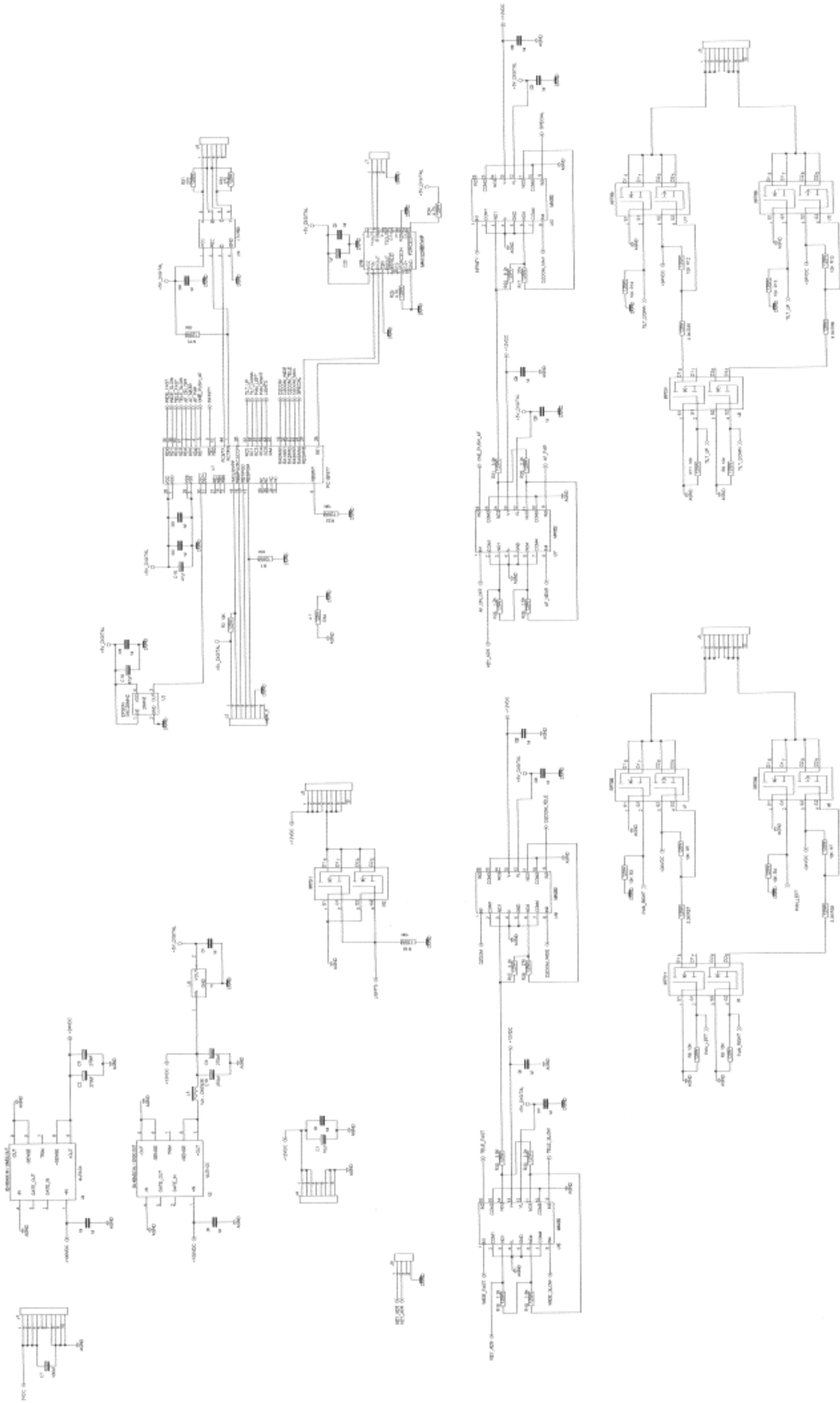

Figure 21. Downhole Camera Control Circuit Schematic

**Figure 22** is a photograph of the physical printed circuit board produced from this schematic. The board is a four-layer board made of FR4 material, measures 3 inches wide x 10 inches long, and is housed inside the robotics base module. Worthy of note are the large heat sinks for the DC-to-DC power converters used to take the single DC voltage supplied from the surface and generate +24V, +12V and +5 VDC regulated power for the various camera functions.

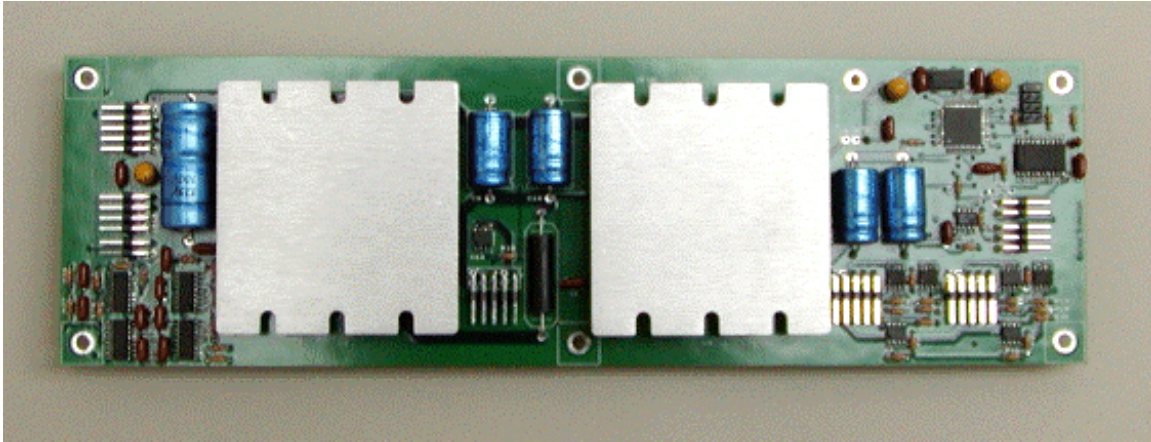

Figure 22. Downhole Camera Control Circuit Board

The PIC controller (PIC16F877) is a 20-MHz CMOS FLASH-based 8-bit microcontroller. It features 256 bytes of EEPROM data memory, self-programming, an ICD, eight channels of 10-bit Analog-to-Digital (A/D) converter, two additional timers, and two capture/compare/PWM functions. The synchronous serial port can be configured as either three-wire Serial Peripheral Interface (SPI™) or the two-wire Inter-Integrated Circuit (I<sup>2</sup>C™) bus and a Universal Asynchronous Receiver Transmitter (USART). This controller is designed for more advanced A/D applications in automotive, industrial, appliances and consumer applications.

In the fifth quarter, the camera control software and display were finalized. **Figures 23 and 24** show the packaged electronics and camera display/control functions as presented on a laptop computer.

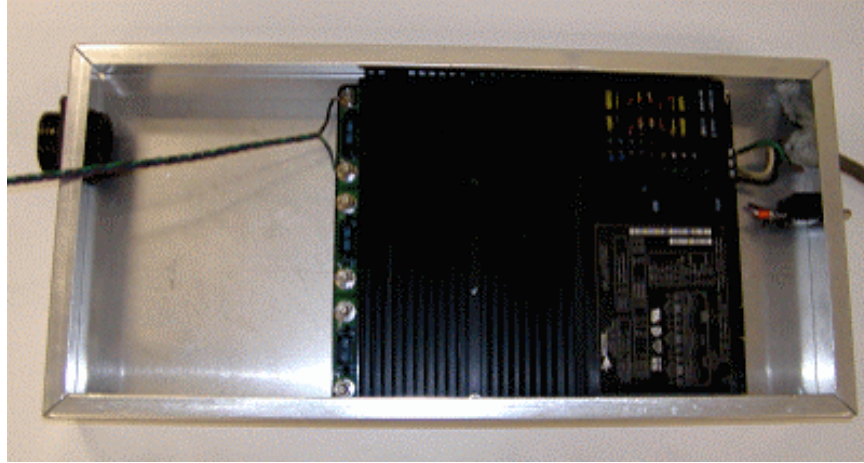

Figure 23. PZT Camera Power Supply



Figure 24. Camera Display and Control Software

A four-arm assembly for cleaning the pipe wall prior to installing the repair sleeve, initially built during the second quarter, was further developed during the third and fourth quarters. It was suitable for removing a wide range of debris including very hard deposits. It had a collapsed diameter of 6.4 inches and could open up to 13 inches under centripetal action.

During the fifth quarter, the arm assembly was redesigned to be packaged as a complete robotic element. This included both design and fabrication of the drive motor, motor controller electronics, cleaning head housing and collapsible arm (**Figure 25**). The completed robot assembly was tested to clean across several 12-inch cast-iron bell and spigot joints (**Figure 26**). The preliminary tests were very promising. The most efficient cleaning occurs at rotary speeds of 300 rpm with forward and backward movement across the joint at speeds of 4 inches per minute, for approximately 5 minutes per joint.

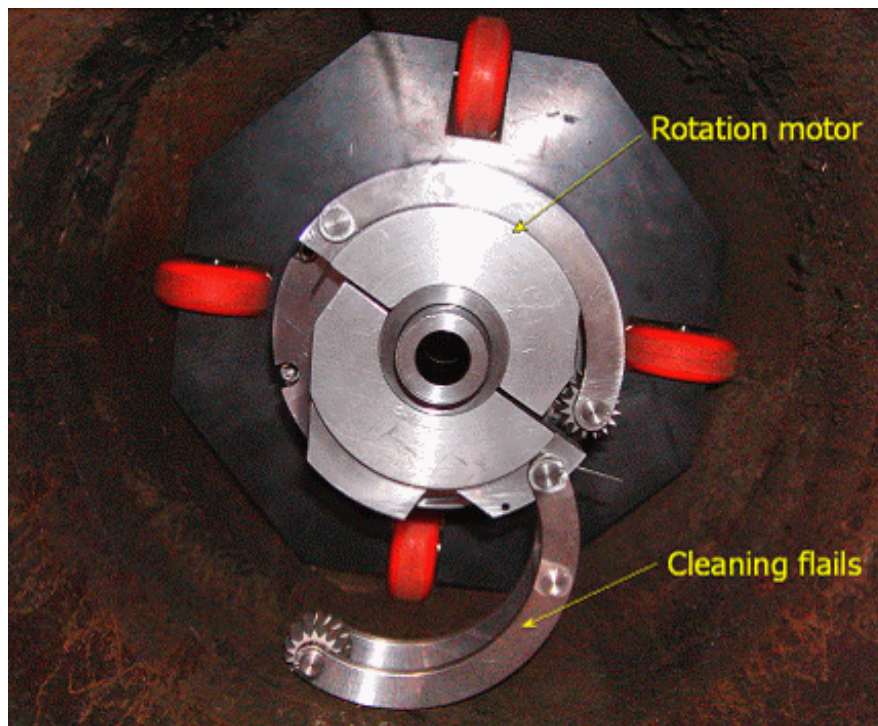

Figure 25. Pipe Wall Cleaning Element



Figure 26. Pipe Wall Cleaning Test

### **Task 6 – Design and Build Surface Control and Monitoring System**

Surface control and monitoring electronics are being designed to operate inside the LabView platform operated on a high-end laptop computer. To this point in the project, we have completed the control software and visual display for the PZT camera and the control software for operating the pipe wall cleaning head. Work in this quarter continued onward with development of the control software for setting the patch inside the pipe. Final packaging will be consistent with construction field-ready practices.

The deliverables for this task will be the Prototype Surface Control and Monitoring System in addition to all corresponding electrical/electronic schematics, specifications, and parts lists.

### **Task 7 – Design and Fabricate Large-Diameter Live Access System**

Since the entry fitting system for cast-iron pipe cannot be welded directly onto the cast iron pipe body (as is possible with steel pipelines), some other means of attachment must be

used. The most viable choice is to weld the longitudinal seams of the split entry fitting to itself and then to provide an end seal against axial movement and a circumferential face seal by end bolting two end pieces. The entry fitting will enable a port to be cut into the main for inserting all joint-patching equipment. The entry fitting must provide sealing for conducting repair operations, as well as maintain a safe seal over the life of the pipeline since the entry fitting will not be removed from the main. Subtasks include:

- 7.1 *Perform Stress Analysis.* A certain portion of the main's cross section will need to be removed for access. The entry-fitting system must possess mechanical properties that ensure that basic mechanical integrity of the main/joint is not compromised. The design must take into account bending/flexure loading, settling, reactive forces, and other environmental factors.
- 7.2 *Design Seal that will be Maintained Under Loaded Conditions.* The fitting and seal design must be robust to accommodate any flexural loading conditions. Seals must remain "energized" at all times during entry and inspection when the main is exposed.
- 7.3 *Perform Sealing Analysis.* The appropriate material must be selected to meet temperature, environmental, and lifetime requirements. An effective seal must be maintained in the event of settling and varying ground conditions.

MTI and GTI met with a leading fitting manufacturer. Numerous designs were subjected to an in-depth review with both the manufacturer and with several utilities having significant amounts of large diameter cast-iron pipes. These efforts have produced a recommended design satisfying the standards in-place at each of the utilities interviewed.

In the previous quarters the fitting was produced in a 4-inch prototype size to validate the design prior to embarking on the fabrication and testing of a 12-inch version which will be considerably more expensive. Sealing tests at pressures up 100 psig were successfully conducted in the quarter along with preliminary drilling tests. **Figures 27 - 30** illustrate its key components.

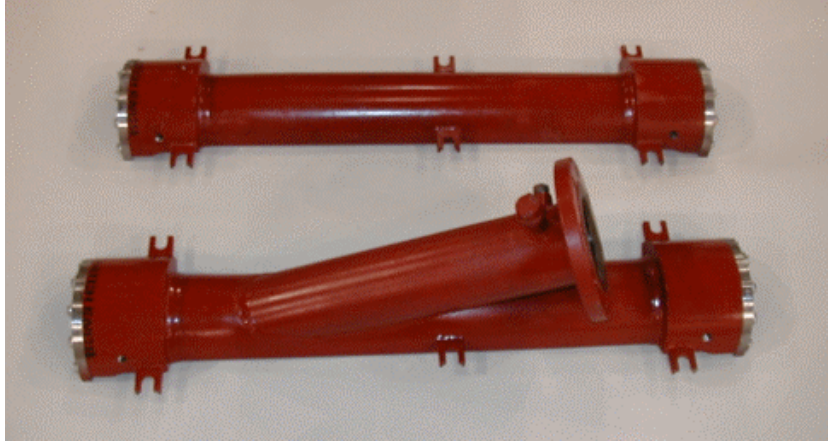

Figure 27. Cast Iron Entry Fitting (4-inch Prototype)

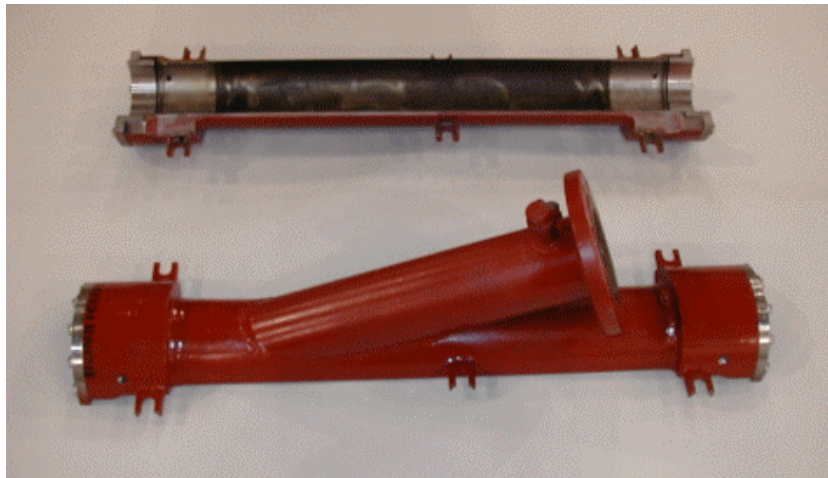

Figure 28. Cast Iron Entry Fitting (4-inch Prototype)



Figure 29. Cast Iron Entry Fitting (4-inch Prototype)

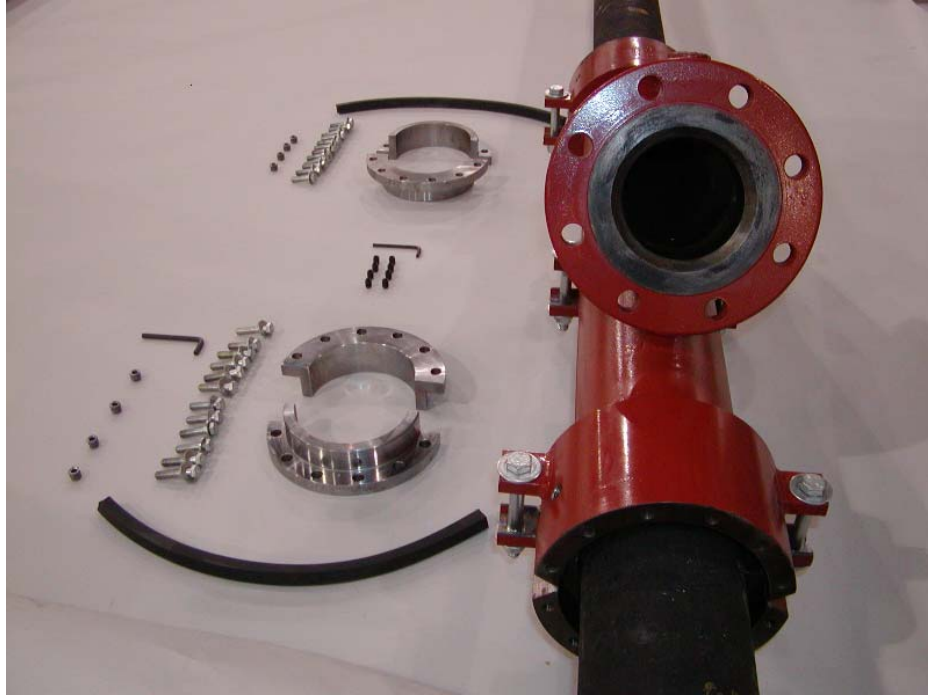

Figure 30. Cast Iron Entry Fitting (4-inch Prototype)

In this quarter, detailed designs of the 12-inch fitting were completed and the design is now in manufacture. **Figures 31-33** identifies the primary aspects of the entry fitting for 12-inch diameter pipes. In addition, to selecting the preferred machine shop for fabrication, the team met with a leading manufacturer of gaskets and seals to make the molds for the elastomer end seals. In addition, a ball valve for supporting the insertion and removal of the robot trains under no blow conditions was also procured.

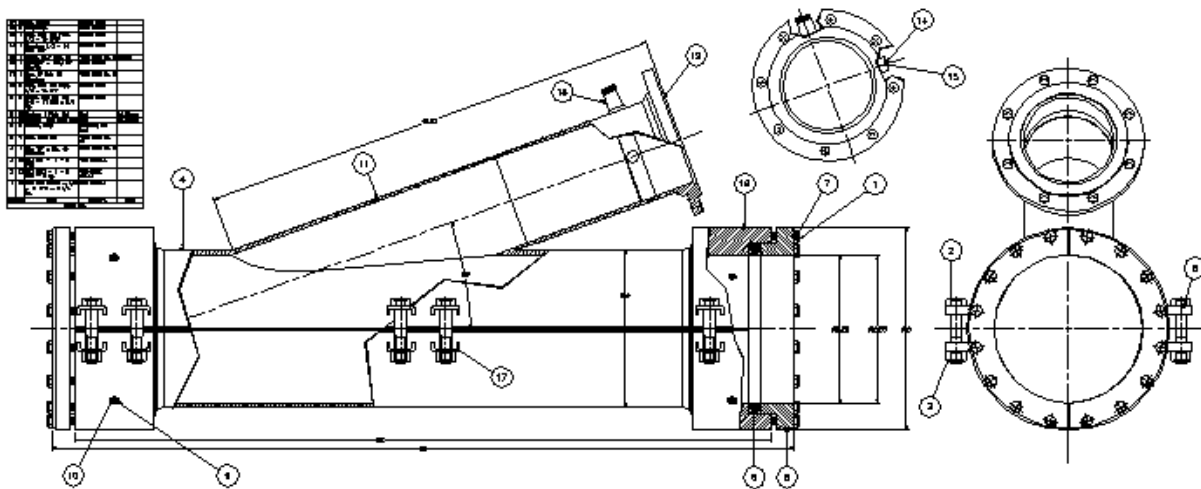

Figure 31. Entry Fitting for 12-inch Diameter Pipes

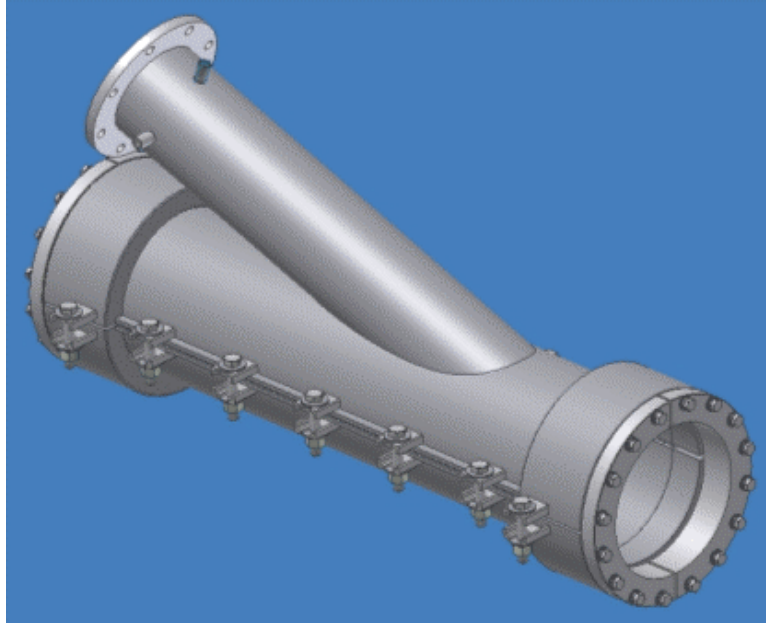

Figure 32. 12-Inch Entry Fitting

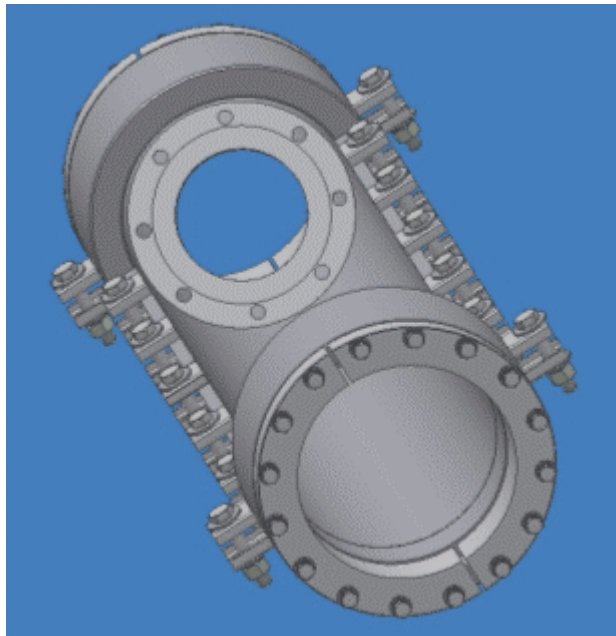

Figure 33. 12-Inch Entry Fitting Cutaway

In order to support use of the 12-inch entry fitting it is also necessary to design the saw cutting system that will cut the angled hole into the pressurized cast iron gas main. A bi-metal hole saw capable of cutting an 8-inch diameter hole has been designed as shown in **Figure 34**. The hole saw has been built and is now scheduled for testing. It will be powered by a 50

horsepower, diesel driven hydraulic power supply. This same power supply also operates the coiled tubing unit.

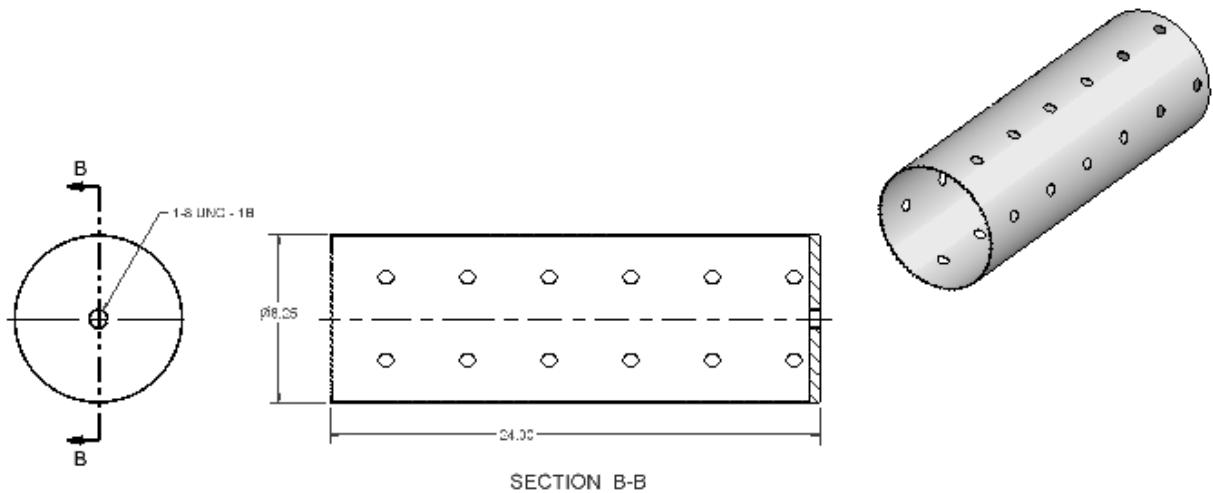

Figure 34. Bi-Metal Hole Saw

## Task 8 – System Integration and Laboratory Validation

While the previous tasks were aimed at addressing specific areas of the proposed work, some aspects of performance will be difficult to assess until components are integrated. To support the evaluation of system performance, a detailed **Test Plan** will be written. Many aspects of the design cannot be accurately evaluated until an integrated test is performed. Some of these items are listed below along with potential means of mitigating difficulties encountered. The test plan will be written as the design progresses to ensure that all sensitive points will be examined as part of an integrated test program.

- 8.1 The team will accumulate valuable experience with the equipment to assure proficiency in the field, to verify that all elements work in concert, etc.
- 8.2 Actual push and pull loads will be measured, because these affect ultimate push range of the integrated hardware assemblies and therefore the number of cast-iron pipe joints which can be repaired from a single entry point
- 8.3 Measurement of actual end loads and the reduction of these loads if necessary to achieve targeted performance

#### 8.4 Evaluation of “whip” (flexible) joint design for fatigue resistance and stiffness under actual entry, translation and removal processes

The deliverable for this task will be the Integrated Test Plan. No activity occurred in this task during the current quarter.

### **Task 9 – Field Testing and System Refinement**

The first-generation system will be evaluated in a series of three field tests. These tests will highlight improvements to “harden” the system for commercial viability. Iterative design augmentations will be implemented and verified. Prior working relationships exist between the project team and the following major U.S. gas utilities: KeySpan Energy (Brooklyn Union Gas and Boston Gas), Consolidated Edison of New York, Public Service Electric & Gas of New Jersey, and Baltimore Gas & Electric. These utilities operate the vast majority of large-diameter cast-iron gas mains in the U.S. and are logical candidates for participating in field tests.

No activity occurred in this task during the current quarter.

### **Task 10 – Benefits Analysis**

Initial work on data collection for conducting benefits analysis was begun. (Note that the majority of work in this task will be conducted after the completion of field tests and detailed discussions with the utilities hosting the tests.) These discussions will address the end-to-end process of implementing the proposed large-diameter cast-iron main repair system in a real-world field environment. Only in this way can the true benefit of the new system be assessed. All aspects of the job will be analyzed, particularly costs of labor (number of personnel and time), traffic management, impact on future maintenance operations for the repaired main, impact to customers, and acceptability of the repair technique. The deliverable of this task will be a report detailing these benefits with a focus on cost and overall benefit to infrastructure reliability using the proposed system.

### **Task 11 – Final Report**

The project final report will document all aspects of design and operation of the system. Final results of the project will be presented to the NETL COR in a meeting in Pittsburgh.

No activity occurred in this task during the current quarter.

## **Work Planned for Next Period**

Planned activities for the next six months will encompass elements of Tasks 5 – 9 and Task 10. Specific work items will include:

1. Continued testing of the pipe wall cleaning module in conjunction with the PZT camera under increasingly more difficult and realistic conditions. These tests will be conducted in the laboratory with larger in-pipe travel distances, introduction of more debris, and full exercise of the control electronics and software.
2. Continued testing of the patch-setting module and its use in setting the latest generation 12-inch repair sleeves. Test results will be used to optimize design of the patch assembly and the patch-setting robot train.
3. Fabrication and testing of 12-inch version of the cast-iron bolt-on entry fitting.
4. Fabrication and testing of the bi-metal hole saw used to cut and angled access hole into pressurized cats iron pipes.
5. Continued implementation of software controls and system displays into the LabView user-interface/robotics-control environment.
6. Collection of additional information and data to conduct benefit analysis.

## 4. Conclusions

Activities in this quarter focused on Tasks 4 – 8, with significant progress made in each. Important accomplishments include the following:

1. Task 4 (Design, Fabricate and Test Patch Setting Robotic Train) activities produced an inflatable bladder robotic patch-setting module and its associated pneumatic control electronics. The module was designed, built and used to install ratcheting repair sleeves in pipe samples during this quarter. Preliminary tests were successful, and efforts are progressed to the design of the control electronics to operate the valve attached to a pressurized canister of nitrogen.
2. Task 5 (Design & Fabricate Pipe-Wall Cleaning Robot Train with Pan/Zoom/Tilt Camera) has progressed to design, fabrication and assembly of these robotic elements. The arm assembly was redesigned to be packaged as a complete robotic element. This included design and fabrication of the drive motor, motor controller electronics, cleaning head housing and collapsible arm. The completed robot assembly was tested to clean across several 12-inch cast-iron bell and spigot joints. Preliminary tests were very promising.
3. Task 6 (Design & Build Surface Control and Monitoring System) has been completed with system control and display functions now accomplished through LabView.
4. Task 7 (Design & Fabricate Large Diameter Live Access System) has progressed with design of a bolt-on entry fitting in a 12-inch prototype and design of the pipe wall cutting system.
5. Module-to-module integration of the in-pipe robotic elements has progressed to where the inter-connects and centralizers will be placed into manufacture. Similarly, surface control electronics and software have progressed to include control of wall cleaning, camera and patch setting..

## 5. References

(No references are cited in this Quarterly Report.)