

Issued date: September 12, 1994

RECEIVED
JUN 26 1995
OSTI

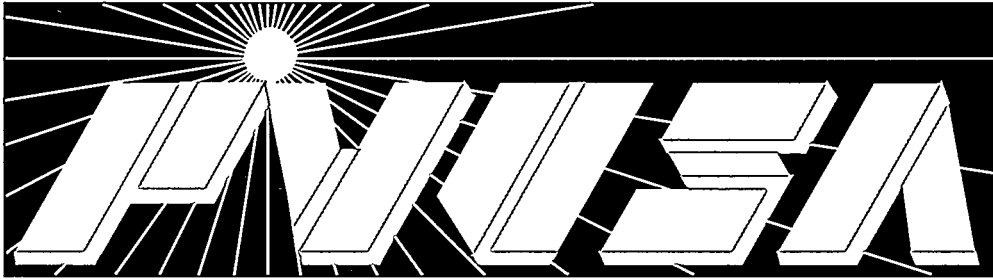

**Magnetic Field Survey
at PG&E Photovoltaic Sites**

August 1994

Prepared by:

**Gregory J. Chang
Christina Jennings**

Project Manager:

Brian K. Farmer

DISCLAIMER

This report was prepared as an account of work sponsored by an agency of the United States Government. Neither the United States Government nor any agency thereof, nor any of their employees, makes any warranty, express or implied, or assumes any legal liability or responsibility for the accuracy, completeness, or usefulness of any information, apparatus, product, or process disclosed, or represents that its use would not infringe privately owned rights. Reference herein to any specific commercial product, process, or service by trade name, trademark, manufacturer, or otherwise does not necessarily constitute or imply its endorsement, recommendation, or favoring by the United States Government or any agency thereof. The views and opinions of authors expressed herein do not necessarily state or reflect those of the United States Government or any agency thereof.

DOE/AL/82993-12
Dist. Category UC-1290

MAGNETIC FIELD SURVEY AT PG&E PHOTOVOLTAIC SITES

August 1994

Gregory J. Chang
Christina Jennings

for

Pacific Gas and Electric Company
Research and Development Department
San Ramon, CA 94583

Published—August 1994

PREPARED UNDER CONTRACT WITH THE UNITED STATES
DEPARTMENT OF ENERGY

Cooperative Agreement No. DE-FC04-92AL82993

0075946/940604/ks071w

DISTRIBUTION OF THIS DOCUMENT IS UNLIMITED
JK

MASTER

DISCLAIMER

Portions of this document may be illegible in electronic image products. Images are produced from the best available original document.

DISCLAIMER

The Pacific Gas and Electric Company (PG&E) and the United States Government or any agency thereof, or any of their employees, contractors, subcontractors and their employees, (1) make no representation or warranty, expressed or implied; (2) assume no legal liability for damages, including any consequential damages, even if PG&E and/or the U.S. Government, or any of their representatives, have been advised of the possibility of such damages; or (3) take no responsibility for the accuracy, completeness, or usefulness of any information, apparatus, product, method, or process disclosed, nor do PG&E or the U.S. Government represent that its use would not infringe the privately held rights of others. Reference herein to any commercial product, process, or service by trade name, trademark, manufacturer, or otherwise, does not constitute or imply its endorsement, recommendation, or favoring by PG&E or the U.S. Government, any agency thereof, or any of their contractors or subcontractors.

The work disclosed in this report was done with the support of the U.S. Department of Energy, Cooperative Agreement No. DE-FCO4-92AL82993. However, any opinions, findings, conclusions, or recommendations expressed herein are those of the author(s) and do not necessarily reflect the views of PG&E or the U.S. Government, any agency thereof, or any of their contractors or subcontractors.

COPYRIGHT NOTICE

Copyright 1994, PG&E, subject to the license retained by the U.S. Government under 48 CFR 952,227-75. All other rights reserved. This report and the underlying research were funded and developed for use by PG&E, members of the PVUSA project, and contributing institutions, including the U.S. Government, the Electric Power Research Institute, and the California Energy Commission. Copies of this report may be obtained for a charge from PG&E or, if for government use or purposes, from the National Technical Information Service in Springfield, Virginia. Reproduction and/or distribution in any form of this report or any part thereof by anyone other than the U.S. Government is forbidden without express written permission from the copyright owner.

PROJECT PARTICIPANTS

In addition to the U.S. Department of Energy (including Sandia National Laboratory, National Renewable Energy Laboratory and Jet Propulsion Laboratory), the Electric Power Research Institute, and the California Energy Commission, the support of all the PVUSA Project members in conducting this research and developing this report is greatly appreciated. Members at the time of publication are:

Central and South West Services, Inc.

City of Austin, Texas

New York State Energy Research and Development Authority

Niagara Mohawk Power Corporation

Public Service Company of Colorado

Sacramento Municipal Utility District, California

Salt River Project

San Diego Gas + Electric

State of Hawaii/Maui Electric Company

U.S. Department of Defense

Virginia Power Company/Commonwealth of Virginia

ACKNOWLEDGMENTS

The authors wish to thank Kurt Bell and Maria Ly, for their assistance with EMF data acquisition, and Susan Moxley, for editing the report.

EXECUTIVE SUMMARY

Public awareness has aroused concerns over the possible effects of magnetic fields on human health. While research continues to determine if magnetic fields do, in fact, affect human health, concerned individuals are requesting data on magnetic field sources in their environments to base personal decisions about limiting their exposure to these sources. Timely acceptance and implementation of photovoltaics (PV), particularly for distributed applications such as PV rooftops, windows, and vehicles, may be hampered by the lack of PV magnetic field data.

To address this situation, magnetic flux density was measured around equipment at two PVUSA (Photovoltaics for Utility Scale Applications) project sites in Kerman and Davis, California. This report documents the data and compares the PV magnetic fields with published data on more prevalent magnetic field sources.

Although not comprehensive, electric and magnetic field (EMF) data taken at PVUSA indicate that 60-Hz magnetic fields (the EMF type of greatest public concern) are significantly less for PV arrays than for household applications. Therefore, given the present EMF research knowledge, PV array EMF may not merit considerable concern. The PV system components exhibiting significant AC magnetic fields are the transformers and power conditioning units (PCUs). However, the AC magnetic fields associated with these components are localized and are not detected at PV system perimeters. Concern about transformer and PCU EMF would apply to several generation and storage technologies.

Project Manager

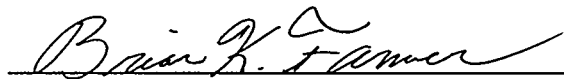

Brian K. Farmer

Research Director

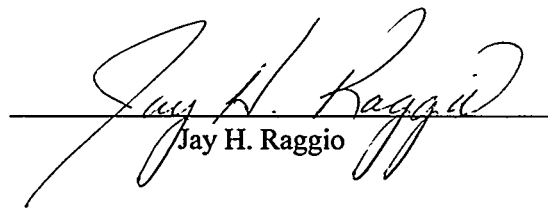

Jay H. Raggio

CONTENTS

| | Page |
|--|------|
| 1 INTRODUCTION | 1-1 |
| 2 MEASUREMENT PROCESS AND INSTRUMENTATION | 2-1 |
| MEASUREMENT PROCESS | 2-1 |
| INSTRUMENTATION | 2-1 |
| 3 RESULTS | 3-1 |
| DAVIS SPOT AND PROFILE MEASUREMENTS | 3-1 |
| DAVIS MULTIWAVE MEASUREMENTS | 3-11 |
| KERMAN SPOT AND PROFILE MEASUREMENTS | 3-11 |
| 4 DISCUSSION | 4-1 |
| DAVIS EMT-1 AREA | 4-1 |
| DAVIS US-1 AREA | 4-1 |
| KERMAN | 4-3 |
| 5 CONCLUSIONS | 5-1 |
| 6 REFERENCES | 6-1 |

FIGURES

| Figure | Page |
|---|------|
| 2-1 Functional components of the EPRI STAR | 2-3 |
| 2-2 EMDEX II meter | 2-3 |
| 2-3 MultiWave wave capture system | 2-4 |
| 3-1 General arrangement of facilities in the EMT-1 area, Davis | 3-2 |
| 3-2 General arrangement of facilities in the APS US-1 area, Davis | 3-3 |
| 3-3 General arrangement of facilities in the SSI US-1 area, Davis | 3-4 |
| 3-4 Map of profiles taken in the EMT-1 area, Davis | 3-5 |
| 3-5 Magnetic field vs. distance in the EMT-1 area (Profile 1), Davis | 3-6 |
| 3-6 Magnetic field vs. distance in the EMT-1 area (Profiles 2 to 5), Davis | 3-7 |
| 3-7 Spot measurements around the SSI PCU, Davis | 3-9 |
| 3-8 Spot measurements around the SSI PV array, Davis | 3-10 |
| 3-9 Map of profiles taken in the APS US-1 area, Davis | 3-12 |
| 3-10 Map of profiles taken in the SSI US-1 area, Davis | 3-13 |
| 3-11 Magnetic field contour plot in the APS US-1 area (EMDEX II/LINDA), Davis | 3-14 |
| 3-12 Magnetic field contour plot in the SSI US-1 area (EMDEX II/LINDA), Davis | 3-15 |
| 3-13 Magnetic field contour plot in the APS US-1 area (STAR/VANA), Davis | 3-16 |
| 3-14 Magnetic field contour plot in the SSI US-1 area (STAR/VANA), Davis | 3-17 |
| 3-15 MultiWave frequency analysis of Davis EMT-1, Dataset 1 | 3-18 |
| 3-16 MultiWave frequency analysis of Davis EMT-1, Dataset 2 | 3-19 |
| 3-17 MultiWave frequency analysis of Davis EMT-1, Dataset 3 | 3-20 |
| 3-18 MultiWave frequency analysis of Davis EMT-1, Dataset 4 | 3-21 |
| 3-19 MultiWave frequency analysis of Davis EMT-1, Dataset 5 | 3-22 |
| 3-20 MultiWave frequency analysis of Davis EMT-1, Dataset 6 | 3-23 |
| 3-21 DC magnetic fields near PVUSA Davis EMT-1 PV arrays | 3-24 |
| 3-22 General arrangement and profile map at Kerman | 3-25 |
| 3-23 Magnetic field contour plot at Kerman | 3-26 |
| 4-1 Comparison of back-of-module magnetic field measurements | 4-2 |

TABLES

| Table | | Page |
|-------|--|------|
| 3-1 | PVUSA Davis EMT-1 PCU Loading Data | 3-8 |

Section 1

INTRODUCTION

Epidemiological studies have raised concerns about possible health effects of exposure to electric and magnetic fields (EMFs) from power lines and electrically powered equipment. Federal agencies, universities, medical research centers, and utilities have ongoing research programs to determine whether, and under what conditions, EMF may cause or contribute to adverse health effects. Although it is unclear what aspect of the field (e.g., field strength, frequency, transients), if any, may affect health, public concern is increasing. Magnetic fields, unlike electric fields, are not easily shielded and pass through most objects. Currently, the public is more concerned about magnetic fields than electric fields.

To address public concern regarding magnetic fields, PG&E established a policy to consider EMF in the design, planning, and construction of new and remodeled facilities, including PG&E-owned PV systems. In addition, PG&E and other electric utilities offer EMF measurement services to their customers. Since 1988, magnetic field measurements have been conducted at many sites, including schools, offices, and residences.

As part of advancing the research and cost-competitive commercial development of environmentally preferred generation technologies, PG&E manages the PVUSA (Photovoltaics for Utility Scale Applications) project, which collects and reports PV data of interest to PG&E, its customers, and other utilities. This report documents magnetic field data taken in 1992 and 1993 at PVUSA sites in Davis and Kerman, California (Jennings, Chang, and Bell 1993).

Section 2

MEASUREMENT PROCESS AND INSTRUMENTATION

MEASUREMENT PROCESS

Characterization of magnetic fields involves an understanding of electrical sources and how they produce magnetic fields. Measurement of magnetic fields is typically the only option to effectively characterize a complex environment with multiple sources. Magnetic field exposure can be defined by a number of parameters:

1. Magnetic fields vary directly with the current in a cable or an electrical device and as a function of the distance from the source.
2. Typically, exposure is defined in terms of the magnitude or strength of the field.
3. Exposure varies according to the frequency of the source (in units of hertz, Hz).
4. Other parameters include time-weighted average, angle of the AC magnetic field in relation to the earth's magnetic field (primary DC), polarization, and transients.

It is important to mention the various aspects of magnetic field exposure because it is not clear what aspect of magnetic fields may be important if a health risk is established.

INSTRUMENTATION

Instrumentation used to measure magnetic fields typically includes a probe, which measures the induced voltage in a coil of wire, and a detector, which translates the measurement into a magnetic field flux density or equivalent magnetic field strength. Magnetic fields are reported in units of milligauss (mG). Instrumentation varies according to the aspects of the magnetic field that are provided (e.g., magnitude, single axis vs. three axis, root-mean-square [RMS] vs. average, frequency, phasor relationship of field). Our intent was to use a number of instruments to serve as a comparison of the field levels between meters and to provide information about various parameters of the magnetic field exposure that these meters are providing. These devices are calibrated in accordance with IEEE/ANSI standards and are used internationally.

Magnetic field measurements and identification of their sources were performed with the following instrumentation systems:

- The Electric Power Research Institute's (EPRI) STand Alone Recorder, or STAR, three-axis magnetic field meter (for magnetic field profiles and mapping)
- VANA profile and mapping wheel for STAR (for distance and turn information)

- EMF Digital EXposure meter, or EMDEX II, three-axis magnetic field recorder (for spot measurements)
- LINDA measurement wheel for EMDEX II (similar to VANA)
- MultiWave wave capture system (for magnetic field measurements of 60 Hz and harmonic frequency waveforms up to a maximum of 780 Hz [13th harmonic])

EPRI STAR

The EPRI STAR unit measures 60-Hz RMS magnetic fields along three orthogonal axes. Developed primarily for research purposes, STAR is a portable device that can be used to record magnetic fields vs. time, or it can be integrated with a measurement wheel (VANA) for distance-oriented measurements. The user can program the recorder via toggle and thumbwheel switches. Its only displays are flashing, light-emitting diodes (LEDs). For this study, STAR was used for distance-oriented measurements. Figure 2-1 depicts STAR's functional components.

EMDEX II

Broadband magnetic fields in the extremely low field (ELF) range of 40 to 800 Hz were measured using an EMDEX II magnetic field recorder (Silva 1991). The EMDEX II meter is a portable, hand-held, three-axis meter capable of recording magnetic field values on a temporal, linear, or instantaneous spot measurement basis (Figure 2-2). Its liquid crystal display (LCD) allows the user to view the measured magnetic field values as well as simplify programming via an on-line menu. The meter was set to display the resultant magnetic fields for two frequency ranges: Rb (40 to 800 Hz), which includes the 60-Hz field component, and Rh (100 to 800 Hz), which filters out the 60-Hz field components. Comparison of the two values indicates the amount of influence that non-60-Hz sources contribute to the resultant magnetic field at a single location. Like the STAR/VANA combination, an EMDEX II/LINDA combination unit was used to map several areas in the Davis Utility Scale (US-1) area and the Kerman PV array area. The data recorded from these measurements were compiled to create contour maps of the magnetic fields in those areas.

MultiWave Wave Capture System

The Electric Research and Management (ERM) MultiWave system was used to measure both AC and DC magnetic fields near the PV modules (Dietrich et al. 1992). This system consists of a computer control unit, an interface unit, and remote probes (Figure 2-3). Data from this system enable us to better analyze other characteristics of magnetic fields (e.g., harmonics, polarization, and angle of field). Triaxial magnetic field sensors were attached to the system to detect AC magnetic fields. In addition, Barrington triaxial fluxgate probes were used for DC field measurements. The data collected by the probes are digitized and stored by the control unit for subsequent analysis.

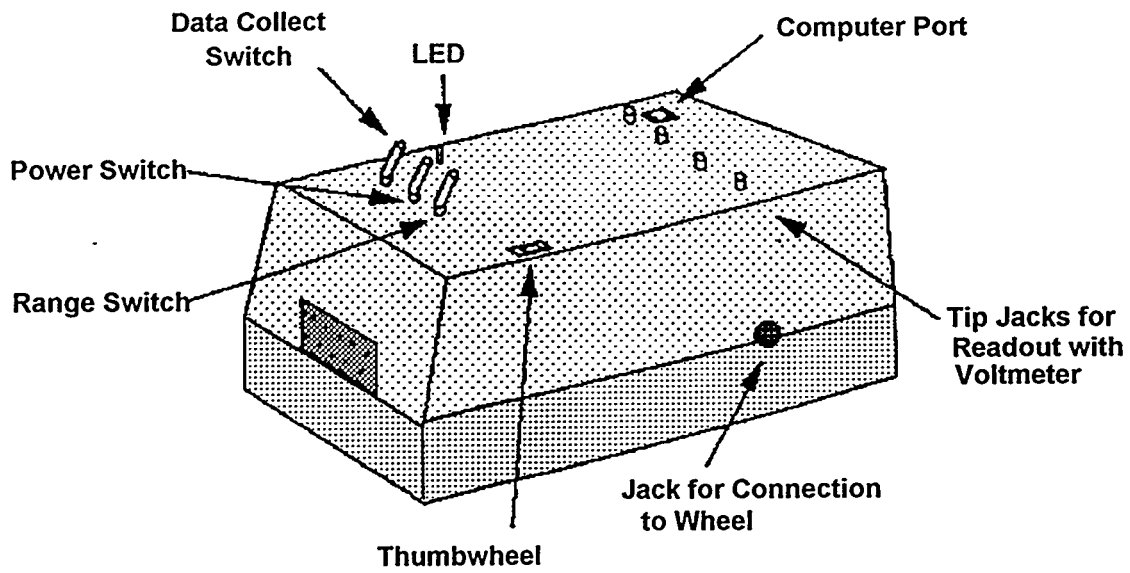

Figure 2-1. Functional components of the EPRI STAR.

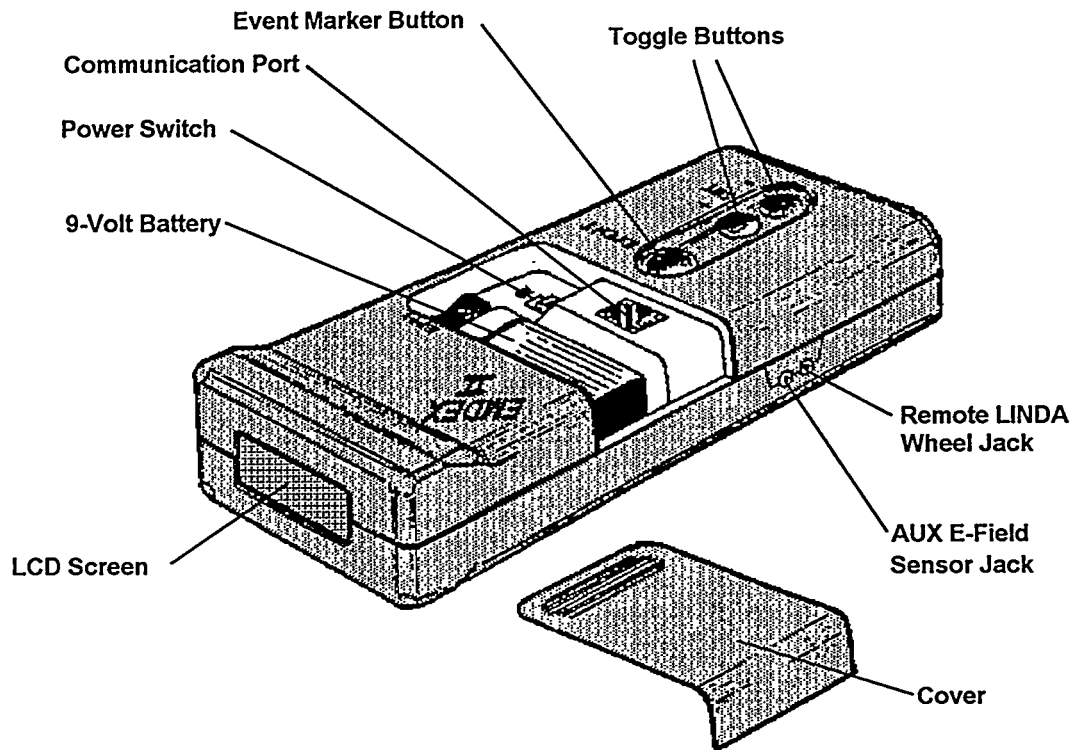

Figure 2-2. EMDEX II meter.

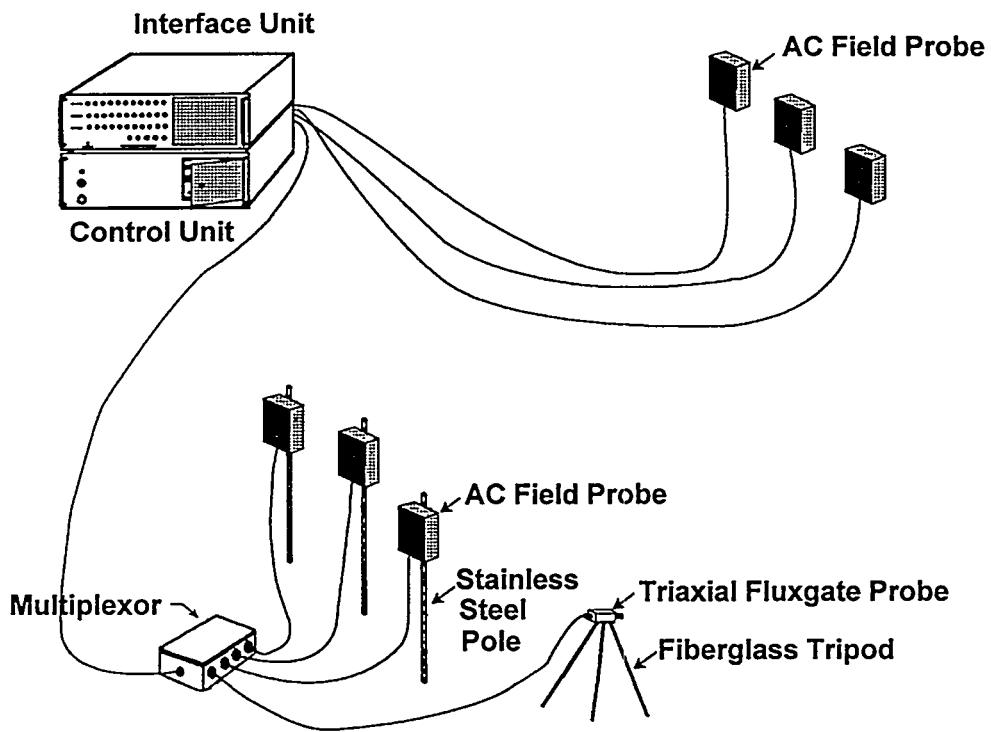

Figure 2-3. MultiWave wave capture system.

Section 3

RESULTS

The magnetic field magnitudes measured using the EMDEX II/LINDA and STAR/VANA meters are reported as resultant field values. The values represent upper limit maximum fields based on measurements along three orthogonal axes (typically denoted as X, Y, and Z). They are determined by computing the square root of the sum of the squares of the field for each direction:

$$B_{\text{resultant}} = \sqrt{X^2 + Y^2 + Z^2}$$

All PVUSA EMF data were acquired midday as expediently as possible to minimize the effects of changing environmental conditions. Magnetic field measurements were taken at a height of approximately 3 feet above grade level, except for measurements associated with the PV arrays and power conditioning units (PCUs). For PV magnetic field measurements, we selected representative modules that would minimize the effects of the support structure, source circuit junction boxes, underground conduits, and PCUs. Measurements were taken as close as possible to the module backs and at distances measured perpendicularly from the module backs toward the ground.

DAVIS SPOT AND PROFILE MEASUREMENTS

Spot and profile measurements were performed on four separate days at the Davis Emerging Module Technology (EMT-1) and US-1 areas. The EMT-2 area was not measured because PV arrays have yet to be installed. Figure 3-1 depicts the arrangement of the EMT-1 area, and Figures 3-2 and 3-3 depict the arrangements of the US-1 areas.

In the EMT-1 area, spot measurements and profiles were taken with EMDEX II and STAR/VANA, respectively. Figure 3-4 shows the profile routes taken by STAR. At the time of the measurement, all EMT-1 arrays, except the Sovonics PV array, were in operation. Figures 3-5 and 3-6 depict the field vs. distance plots for the profiles taken in the EMT-1 area. Magnetic field readings were approximately 0.3 mG, except in the vicinity of the PCUs, where they were as much as 47 mG. Table 3-1 indicates the recorded AC power output readings (in kilowatts, kW) for these measurements.

More detailed spot measurement readings were made around the Siemens Solar Industries (SSI) PCU and PV array (Figures 3-7 and 3-8). The highest field levels were recorded by the power conduit on the side of the power conditioning unit (PCU).

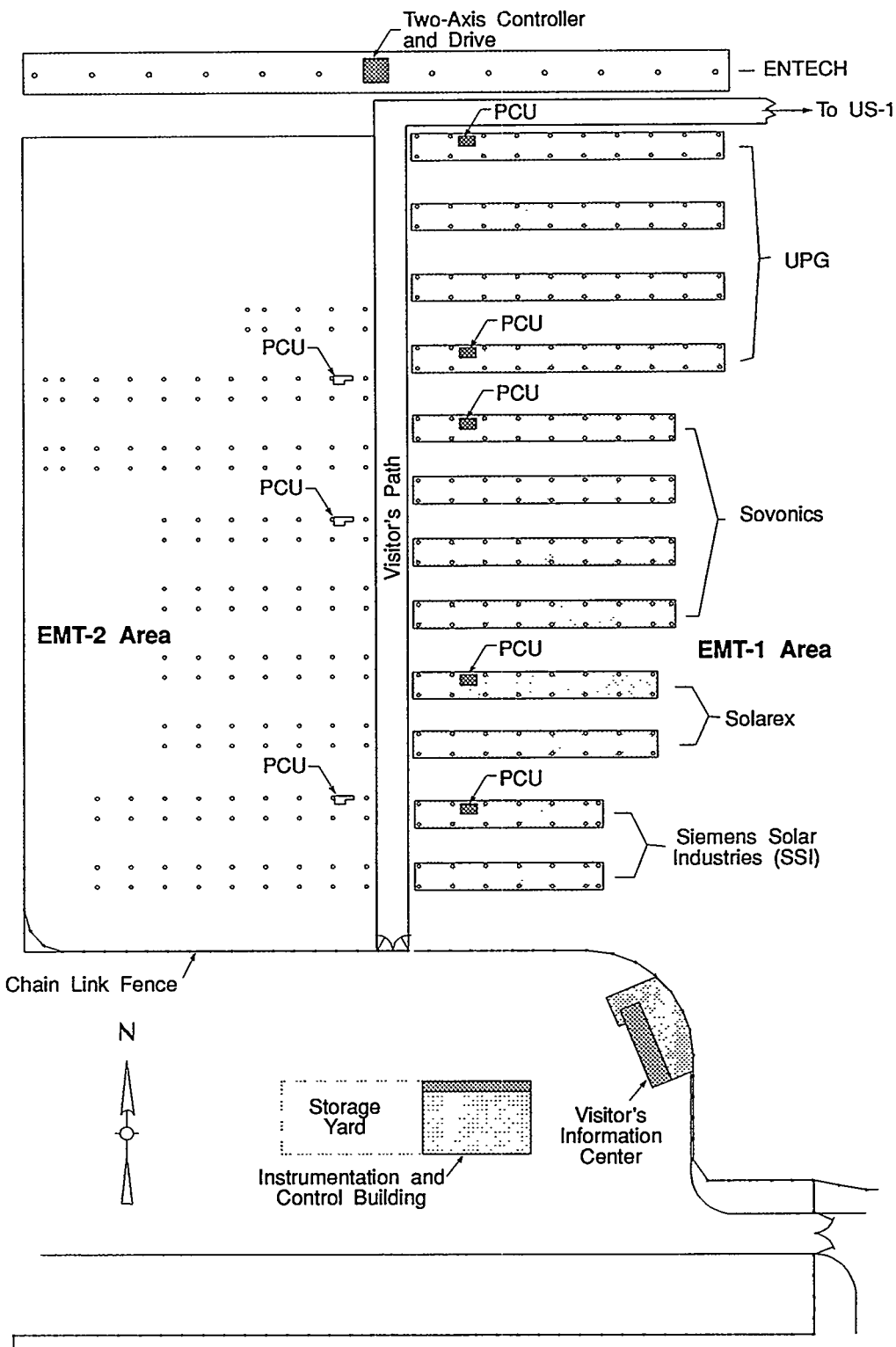

Figure 3-1. General arrangement of facilities in the EMT-1 area, Davis.

March 5, 1993

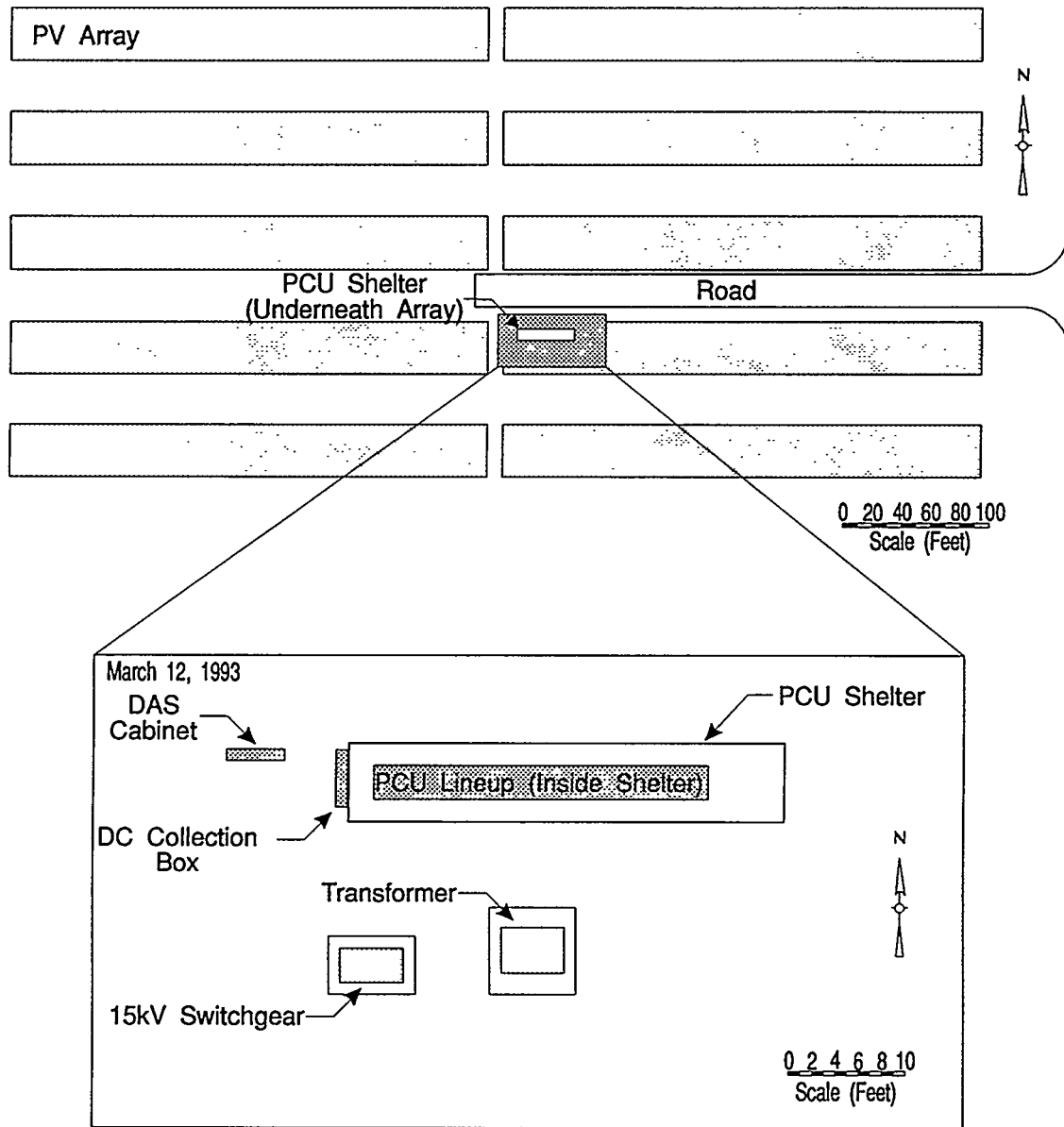

Figure 3-2. General arrangement of facilities in the APS US-1 area, Davis.

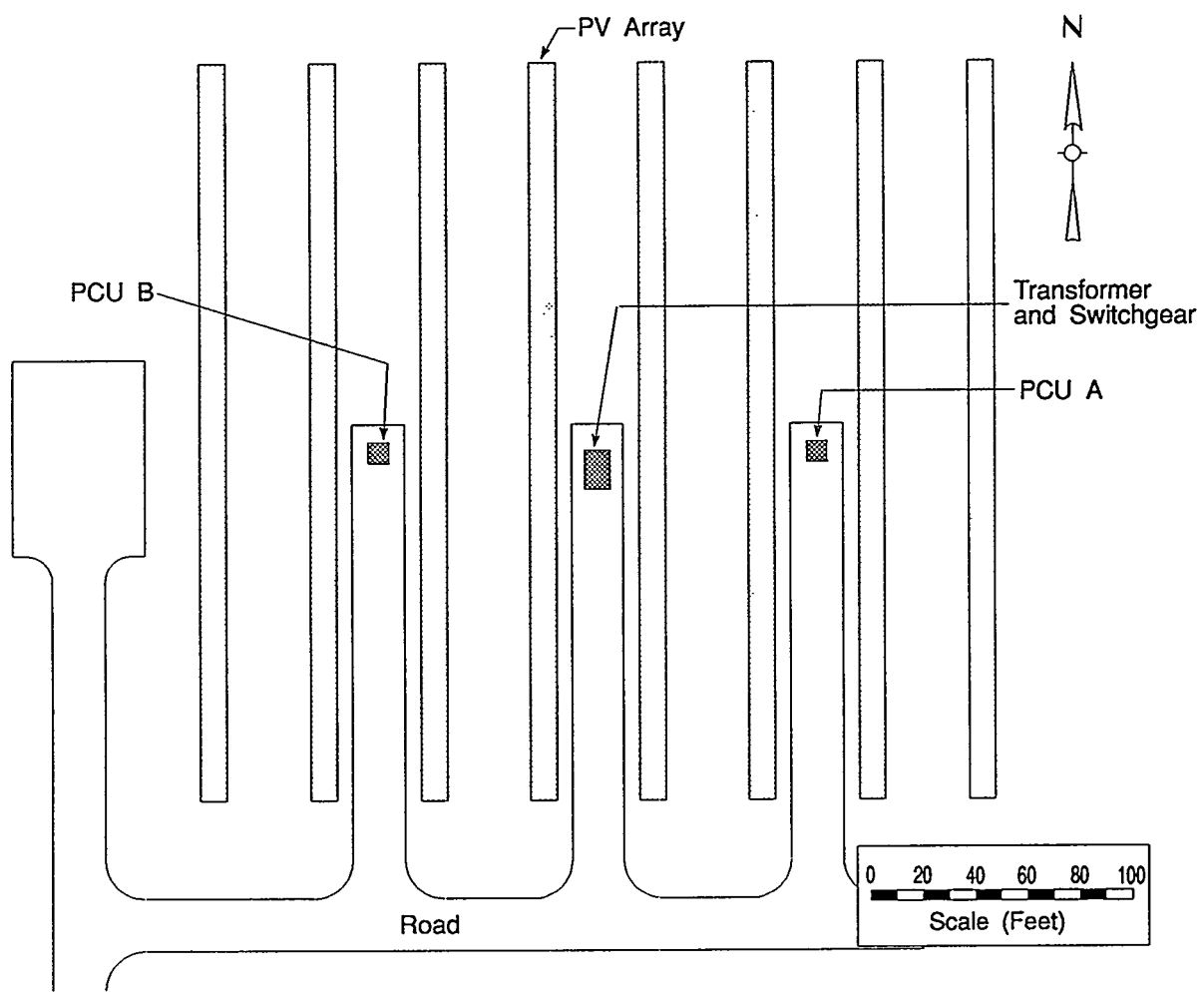

Figure 3-3. General arrangement of facilities in the SSI US-1 area, Davis.

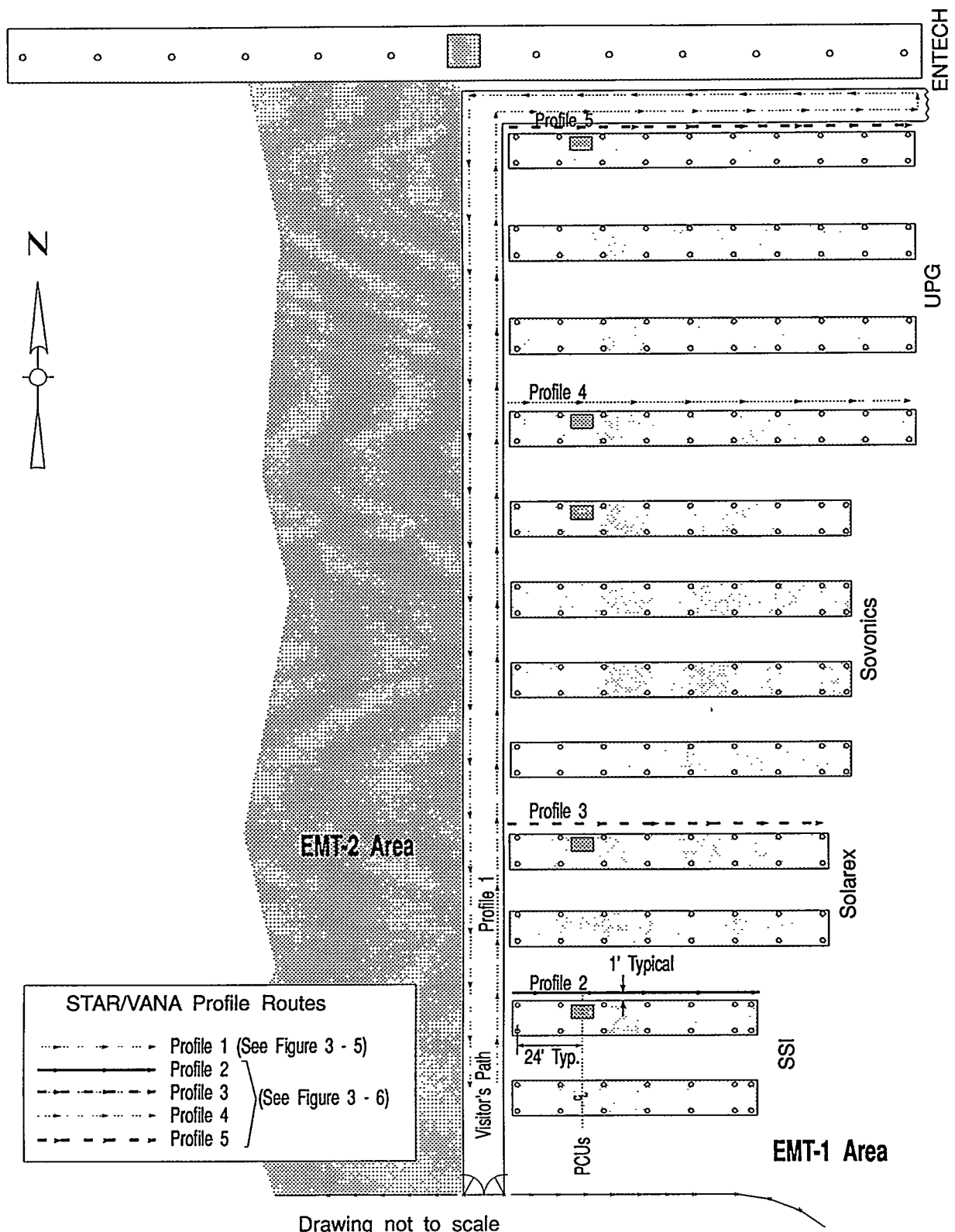

Figure 3-4. Map of profiles taken in the EMT-1 area, Davis.

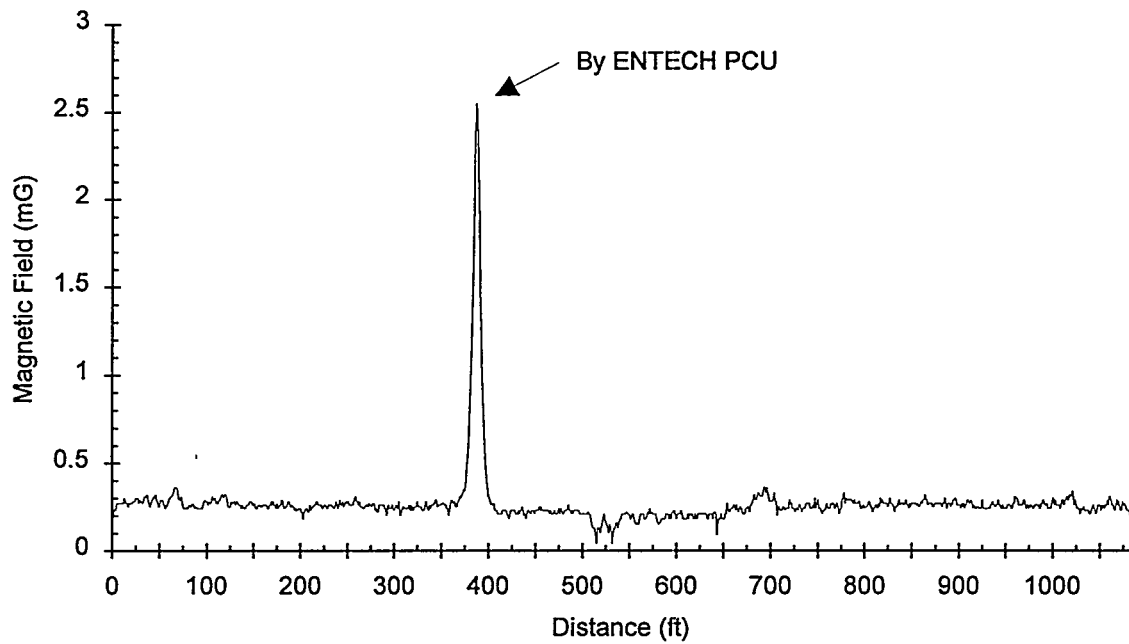

Figure 3-5. Magnetic field vs. distance in the EMT-1 area (Profile 1), Davis.

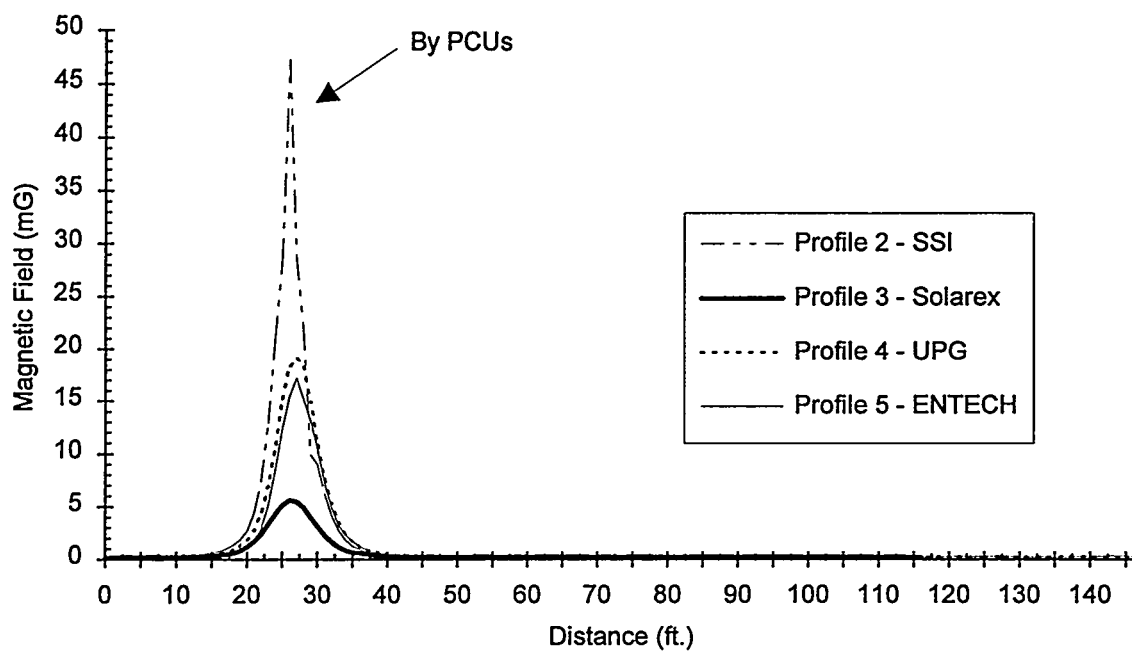
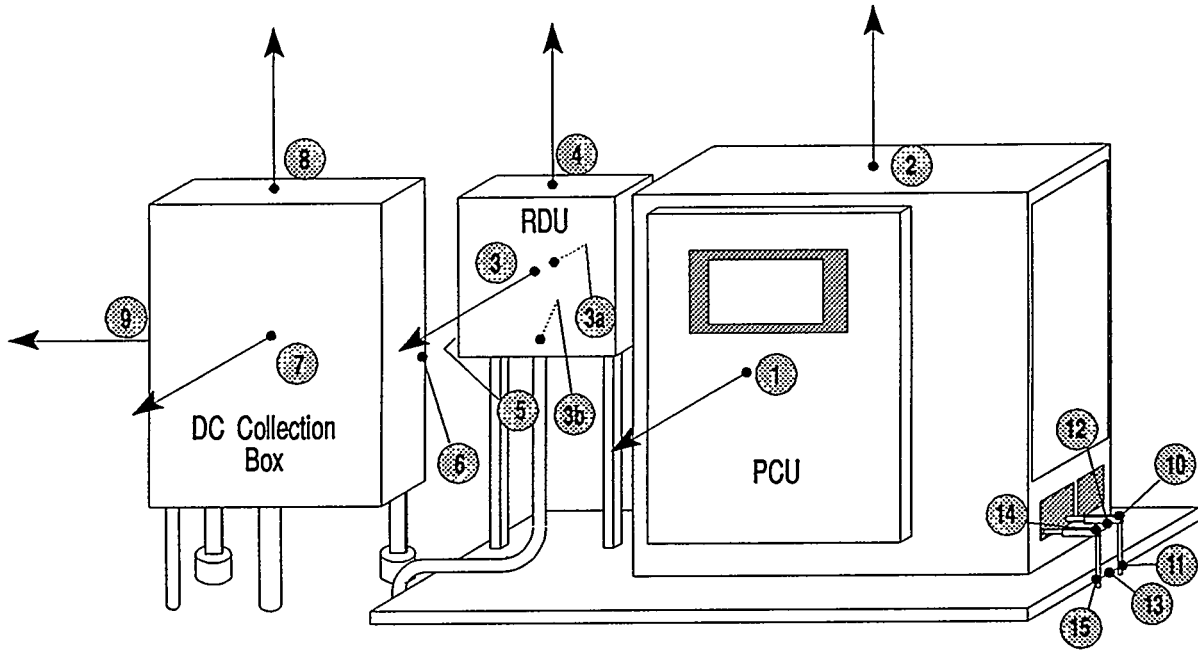

Figure 3-6. Magnetic field vs. distance in the EMT-1 area (Profiles 2 to 5), Davis.

**Table 3-1
PVUSA Davis EMT-1 PCU Loading Data**

| | | |
|----------|------------|--------------------------|
| 6-Apr-92 | PCU | AC Power Out (kW) |
| | SSI | 18.5 |
| | Solarex | 11.5 |
| | UPG | 12.0 |
| | ENTECH | 12.5 |

| 28-Apr-92 | Dataset (Time) | PCU | DC Volts (V) | DC Current (Amps) | DC Power In (kW) | AC Power Out (kW) |
|-----------|-----------------------|---------------------------------|--------------------------|--------------------------|------------------------------|------------------------------|
| | Dataset 1 11:55 AM | SSI Solarex UPG ENTECH | 155 173 148 148 | 53 34 48 49 | 16.2 11.5 13.5 14.5 | 15.9 11.0 13.1 14.0 |
| | Dataset 2 01:50 PM | SSI Solarex UPG ENTECH | 150 168 143 148 | 58 37 50 50 | 17.2 12.0 13.5 14.7 | 17.0 11.5 13.5 14.2 |
| | Dataset 3 02:08 PM | SSI Solarex UPG ENTECH | 149 164 140 147 | 56 36 49 52 | 16.6 12.1 13.8 15.1 | 15.4 11.4 13.3 14.4 |
| | Dataset 4 02:43 PM | SSI Solarex UPG ENTECH | 150 165 142 142 | 52 34 47 52 | 15.5 11.0 13.0 14.5 | 15.1 10.8 13.0 14.1 |
| | Dataset 5 03:10 PM | SSI | 150 | 49 | 14.8 | 14.5 |
| | Dataset 6 03:31 PM | UPG | 150 | 40 | 11.0 | 11.0 |



| No. | Measurement Location | Magnetic Field * | | No. | Measurement Location | Magnetic Field * | |
|-----|--|------------------|---------|-----|------------------------------|------------------|---------|
| | | Rb (mG) | Rh (mG) | | | Rb (mG) | Rh (mG) |
| 1 | Against Face of Inverter | 100.0 | 33.0 | 7 | Against Face of Junction Box | 1.7 | 0.5 |
| | 1' Away | 52.0 | 10.0 | | 1' Away | 2.0 | 0.6 |
| | 2' Away | 32.0 | 6.0 | | 2' Away | 2.0 | 0.6 |
| | 3' Away | 12.0 | 2.4 | | 3' Away | 1.7 | 0.5 |
| 2 | On Top of Inverter | 38.0 | 10.0 | 8 | On Top of DC Collection Box | 2.0 | 0.5 |
| | 1' Above Inverter | 23.0 | 6.0 | | 1' Above DC Collection Box | 2.0 | 0.5 |
| | 2' Above Inverter | 15.0 | 4.0 | | 2' Above DC Collection Box | 1.7 | 0.5 |
| | 3' Above Inverter | 8.3 | 2.3 | | 3' Above DC Collection Box | 1.4 | 0.4 |
| 3 | At face of RDU | 16.0 | 5.2 | 9 | At Side of DC Collection Box | 1.4 | 0.4 |
| | 1' Away | 14.5 | 4.4 | | 1' Away | 1.0 | 0.2 |
| | 2' Away | 10.0 | 3.0 | | 2' Away | 0.7 | 0.2 |
| | 3' Away | 5.0 | 0.5 | | 3' Away | 0.6 | 0.1 |
| 3a | Inside RDU, by PC Board | 35.0 | 11.0 | 10 | Top of Rear Power Conduit | 745.0 | 16.0 |
| 3b | Inside RDU, by Bottom Side | 17.0 | 6.0 | 11 | Base of Rear Power Conduit | 1050.0 | 38.0 |
| 4 | On Top of RDU | 13.6 | 4.0 | 12 | Between Power Conduits | 290.0 | 6.0 |
| | 1' Above | 10.8 | 3.1 | 13 | Between Power Conduits | 80.0 | 9.0 |
| | 2' Above | 7.7 | 2.2 | 14 | Top of Front Power Conduit | 288.0 | 10.0 |
| | 3' Above | 4.6 | 1.3 | 15 | Base of Front Conduit | 598.0 | 25.0 |
| 5 | Lower Left Corner of DC Collection Box | 15.2 | 5.0 | | | | |
| 6 | At Right side of DC Collection Box | 5.53 | 1.4 | | | | |

* Rb = Broadband Resultant Magnetic Field. Frequency Range of 40 Hz to 800 Hz.
Rh = Harmonic Resultant Magnetic Field. Frequency Range of 100 Hz to 800 Hz.

Figure 3-7. Spot measurements around the SSI PCU, Davis.

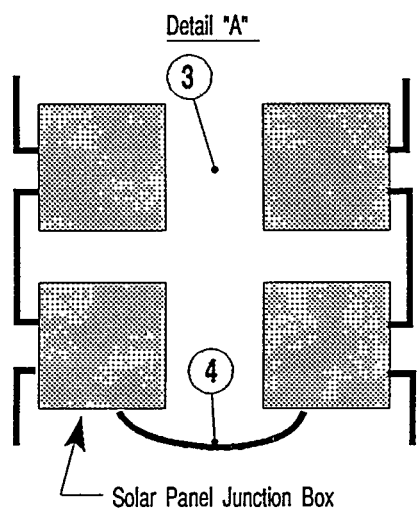
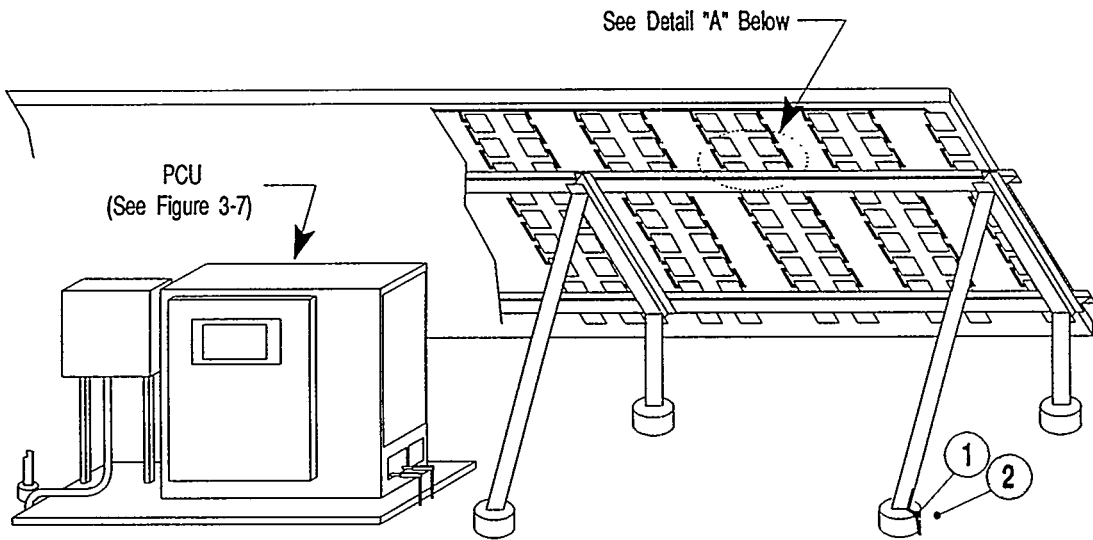

| No. | Measurement Location | Magnetic Field * | |
|-----|------------------------------|------------------|---------|
| | | Rb (mG) | Rh (mG) |
| 1 | By Ground Cable | 3.4 | 1.0 |
| 2 | 1' From Ground Cable | 0.2 | 0.1 |
| 3 | Between Panel Junction Boxes | 1.2 | 0.7 |
| 4 | By Jumper Cable | 5.9 | 3.8 |

* Rb = Broadband Resultant Magnetic Field. Frequency Range of 40 Hz to 800 Hz.
 Rh = Harmonic Resultant Magnetic Field. Frequency Range of 100 Hz to 800 Hz.

Figure 3-8. Spot measurements around the SSI PV array, Davis.

In the US-1 area, profile measurements were primarily taken with an EMDEX II/LINDA unit. Figures 3-9 and 3-10 depict the unit's profile routes. The data were compiled to plot contour maps of the magnetic fields in those areas (Figures 3-11 and 3-12). To isolate the fields from 60-Hz sources, the STAR/VANA unit was used at the same time as the EMDEX II/LINDA unit. The resulting contour plots are illustrated in Figures 3-13 and 3-14.

DAVIS MULTIWAVE MEASUREMENTS

Additional magnetic field measurements were performed at the PVUSA Davis site using the MultiWave wave capture system. Six data recordings were performed in the EMT-1 area (Figures 3-15 to 3-20). The magnetic field levels at the five probe locations and their corresponding magnetic field strengths for a frequency range of 60 to 780 Hz are indicated (magnetic fields are negligible for frequencies higher than 780 Hz). The percentage of the magnetic field due to the fundamental or 60-Hz component is also shown. Data samples were taken at 5-second intervals for 5 minutes per dataset. The time of day had a slight effect on the magnitude of the measurements. Probes were left at the same location. Peak power output of the arrays occurred around 2:00 p.m.

Additional MultiWave measurements were conducted at a later date in the EMT-1 area. Barrington fluxgates were used to record DC magnetic fields. The ambient DC field (0 Hz) was approximately 488 mG on March 12, 1993, around 11:00 a.m. Figure 3-21 plots DC magnetic fields measured as close as possible to the back of two nonadjacent UPG and two nonadjacent SSI EMT-1 PV modules.

KERMAN SPOT AND PROFILE MEASUREMENTS

A final site measurement was taken at PVUSA Kerman with an EMDEX II/LINDA unit. The general arrangement of equipment and profile routes is indicated on Figure 3-22. The resulting broadband (40-800 Hz) magnetic field contour map is shown on Figure 3-23. Maximum broadband and 60-Hz fields are associated with the transformers and PCUs.

March 5, 1993

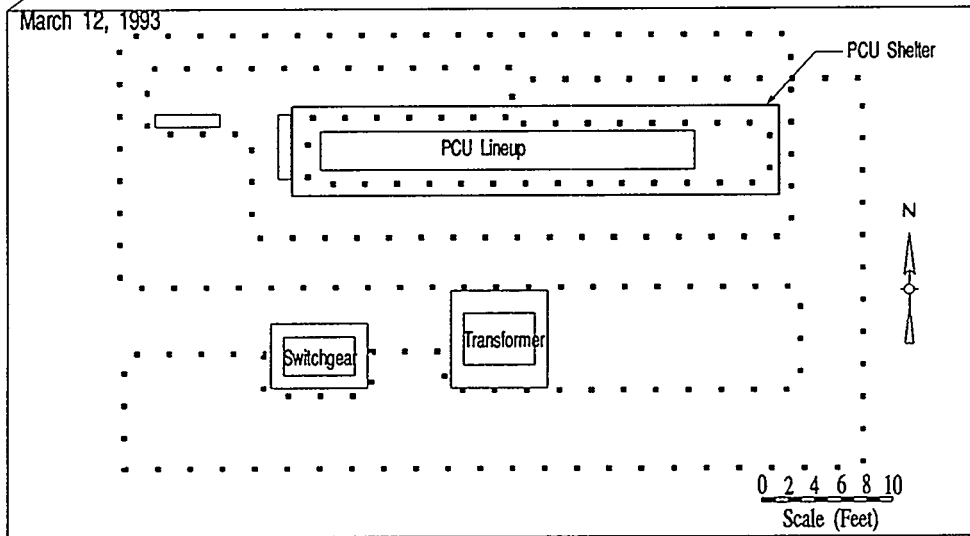
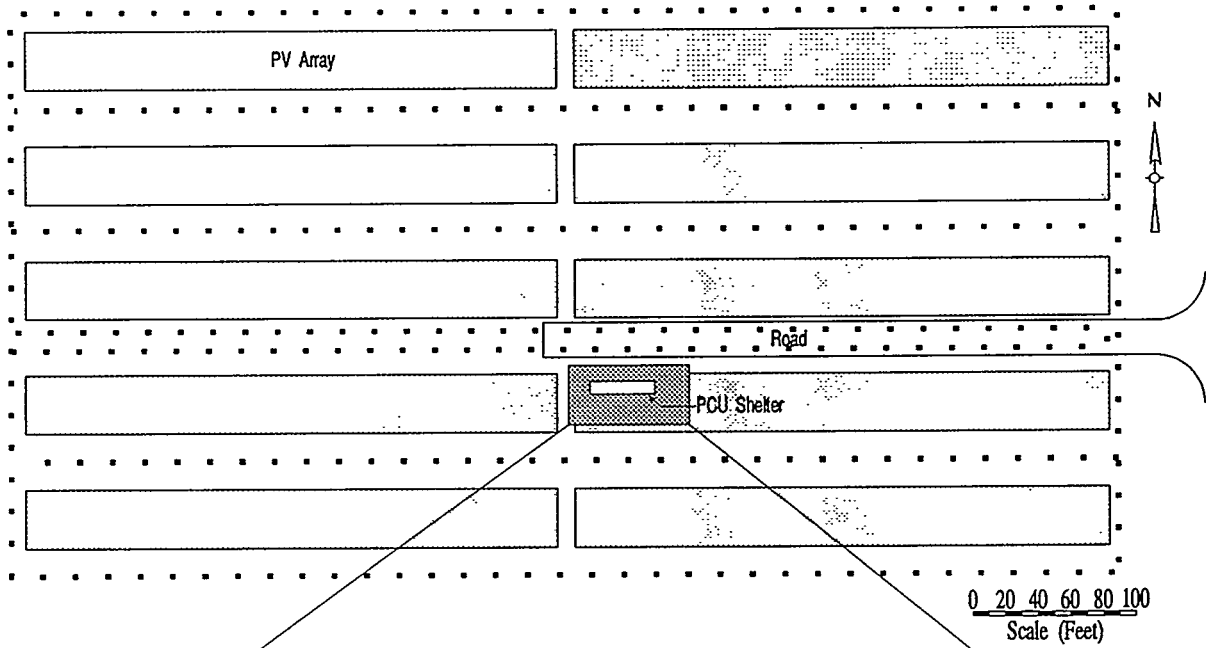

• • • • STAR/VANA and EMDEX II/LINDA Profile Routes

Figure 3-9. Map of profiles taken in the APS US-1 area, Davis.

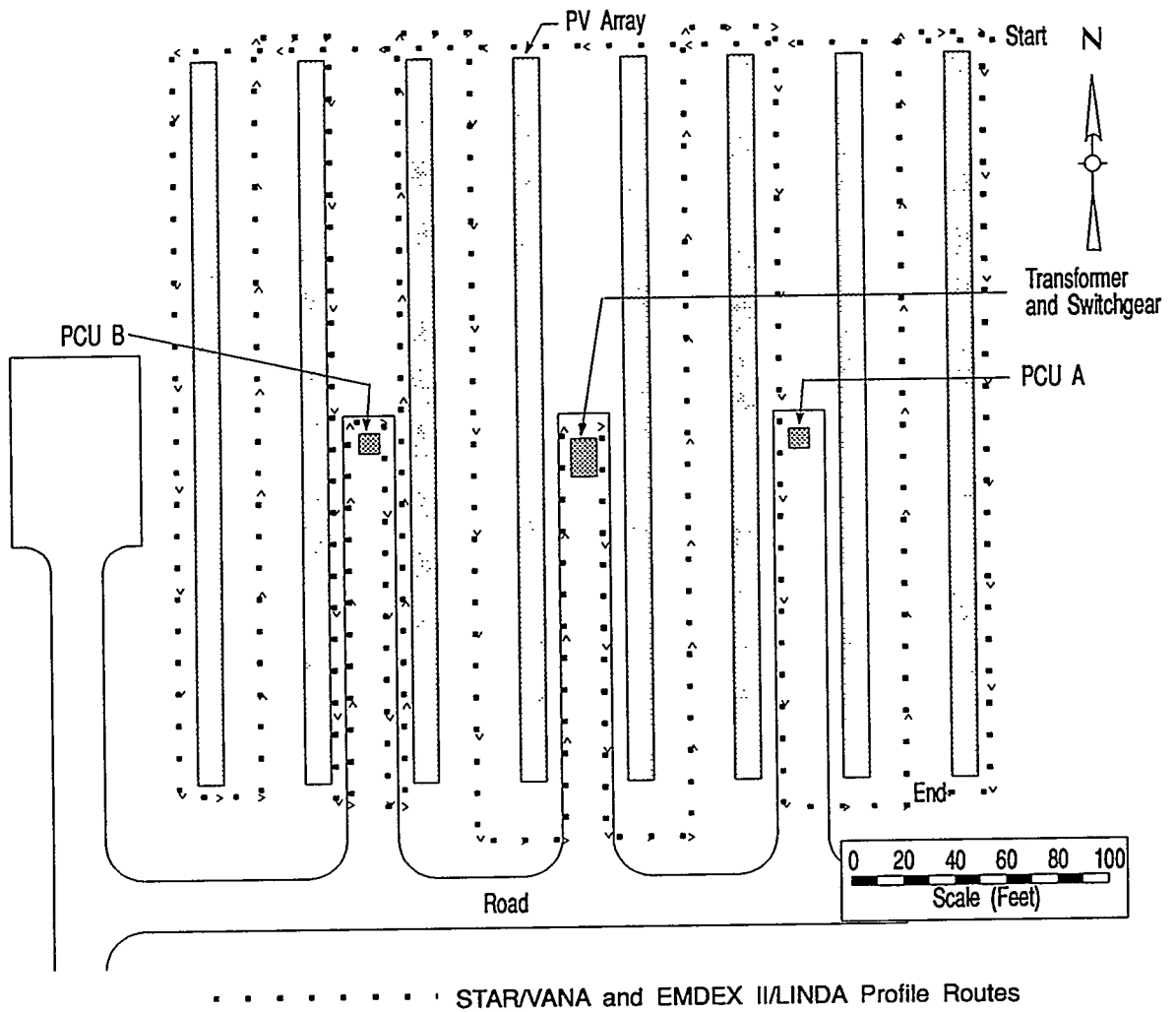
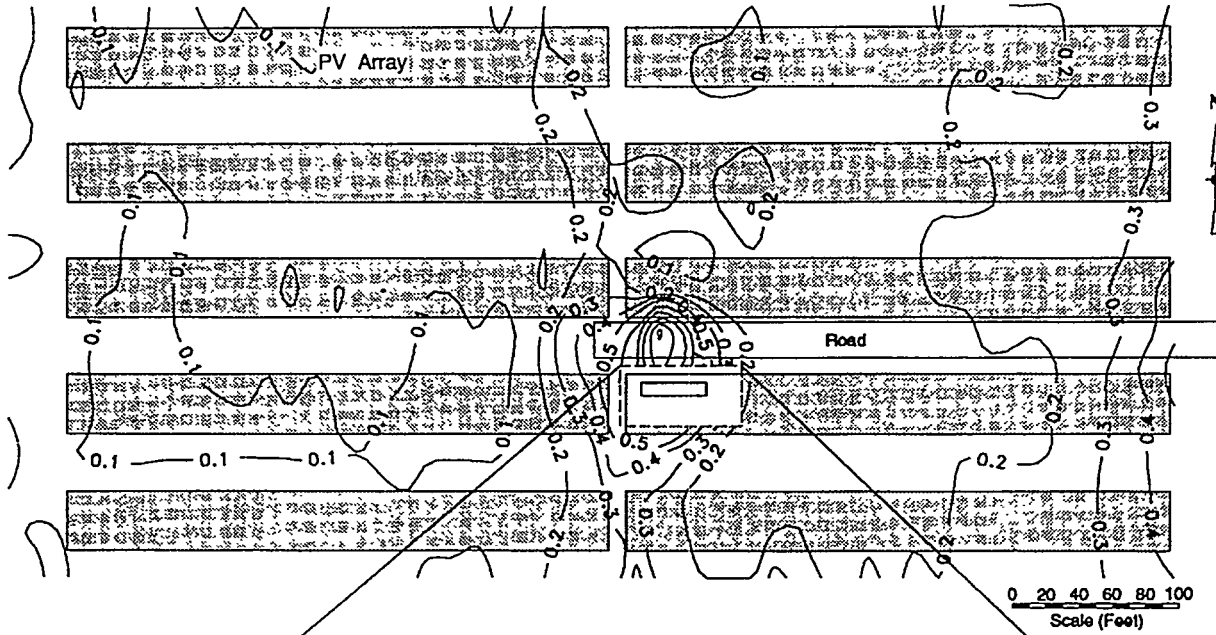

Figure 3-10. Map of profiles taken in the SSI US-1 area, Davis.

March 5, 1993



March 12, 1993

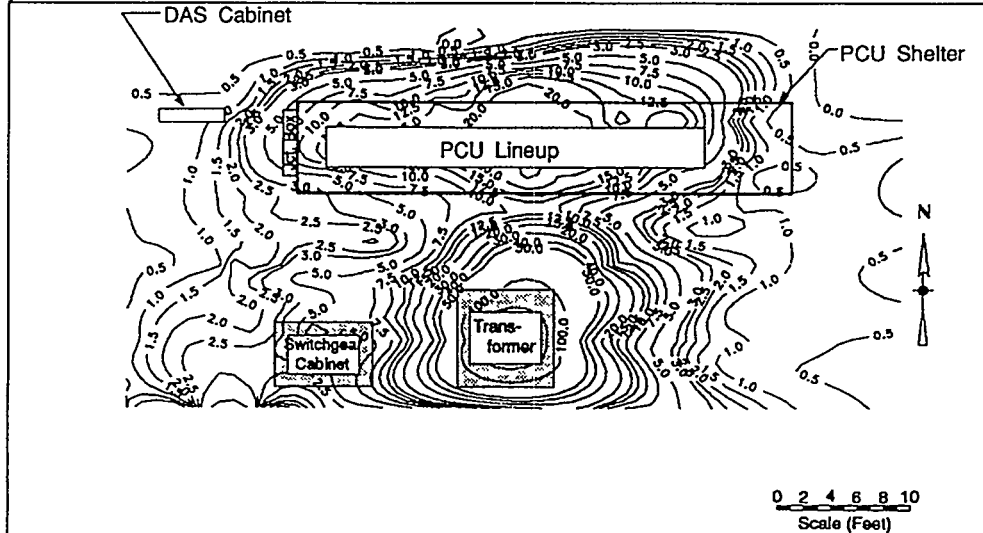

Figure 3-11. Magnetic field contour plot in the APS US-1 area (EMDEX II/LINDA), Davis.

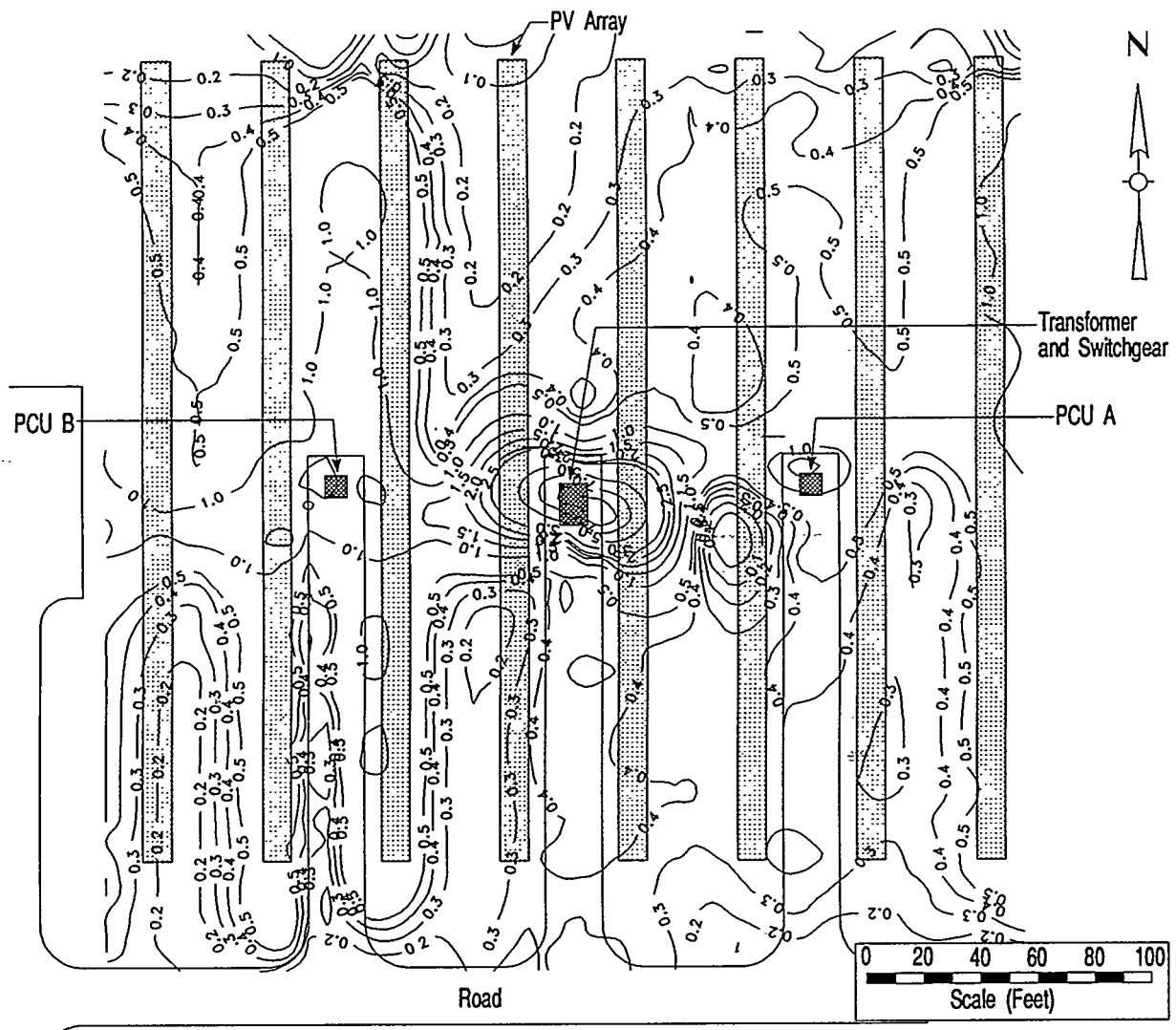
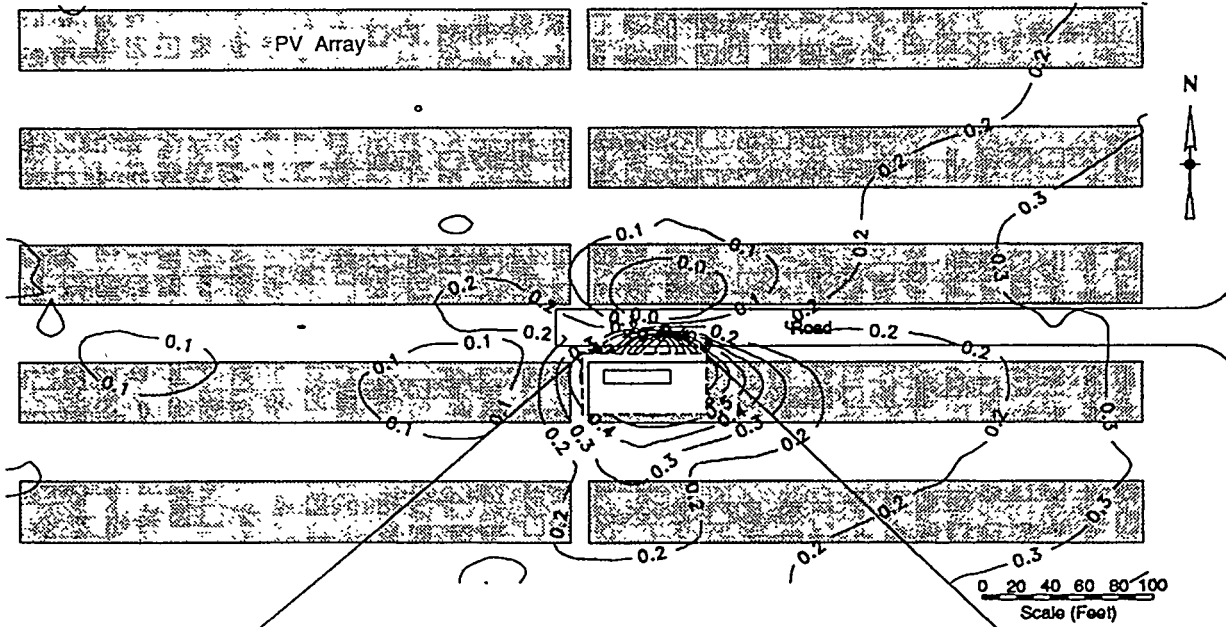

Figure 3-12. Magnetic field contour plot in the SSI US-1 area (EMDEX III/LINDA), Davis.

March 5, 1993



March 12, 1993

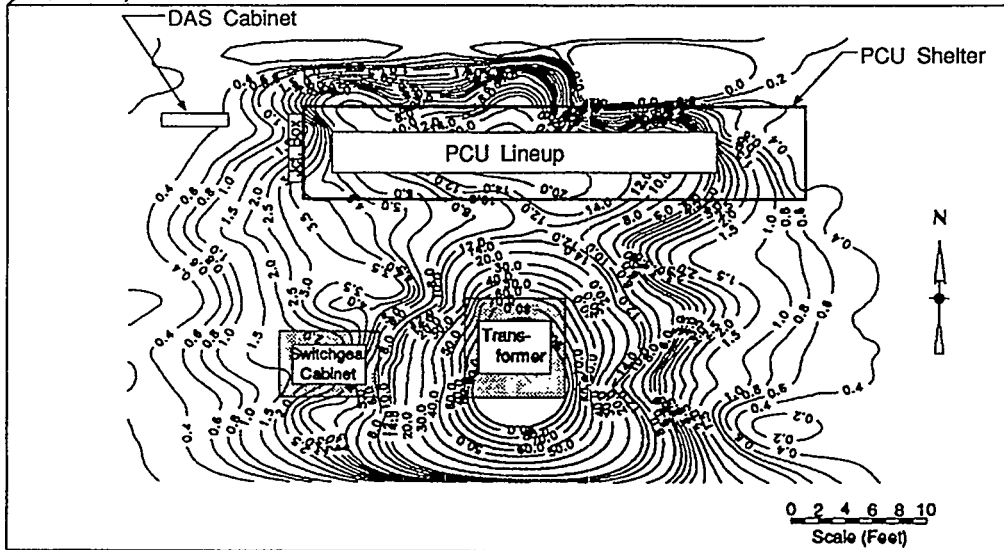

Figure 3-13. Magnetic field contour plot in the APS US-1 area (STAR/VANA), Davis.

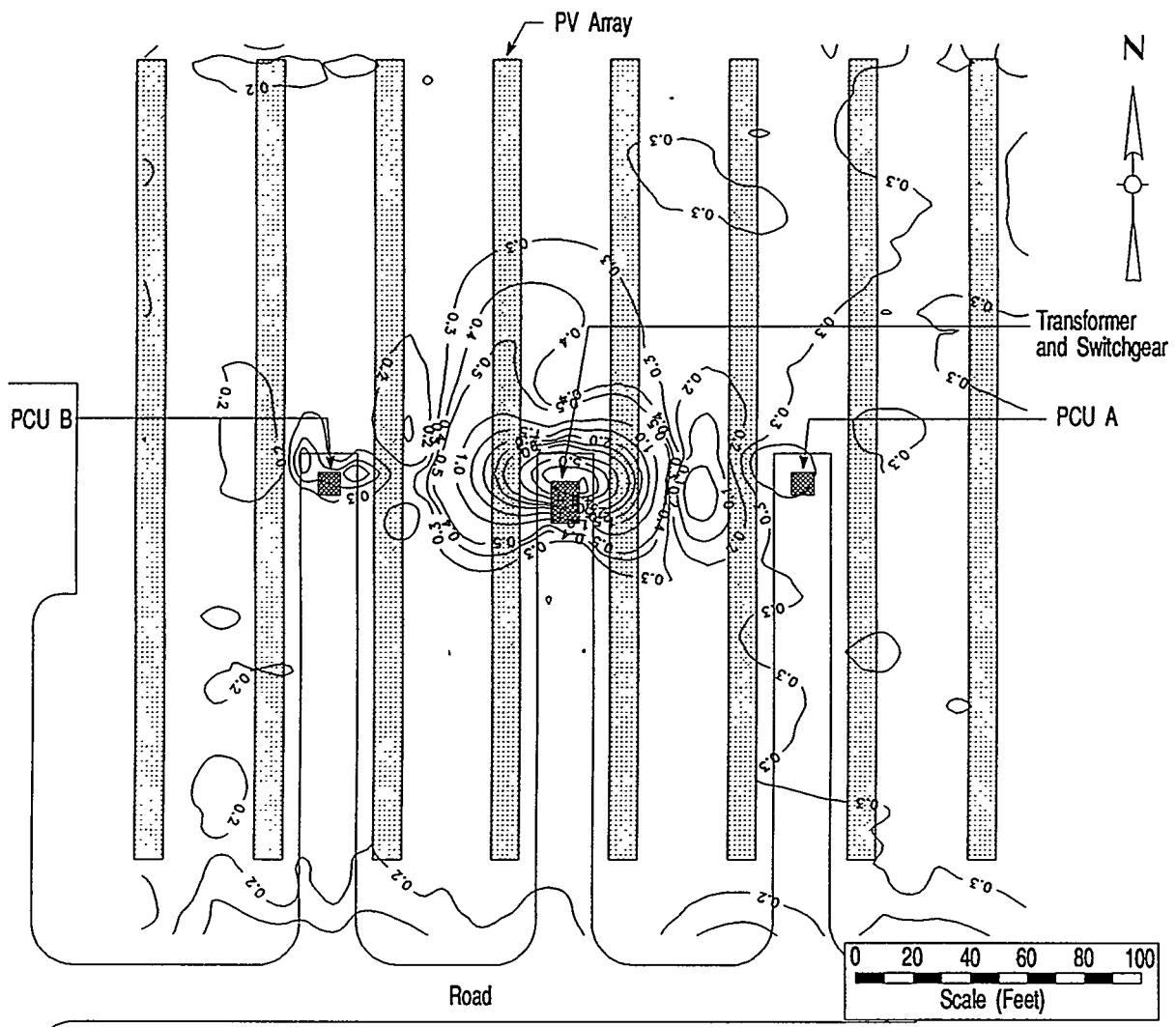
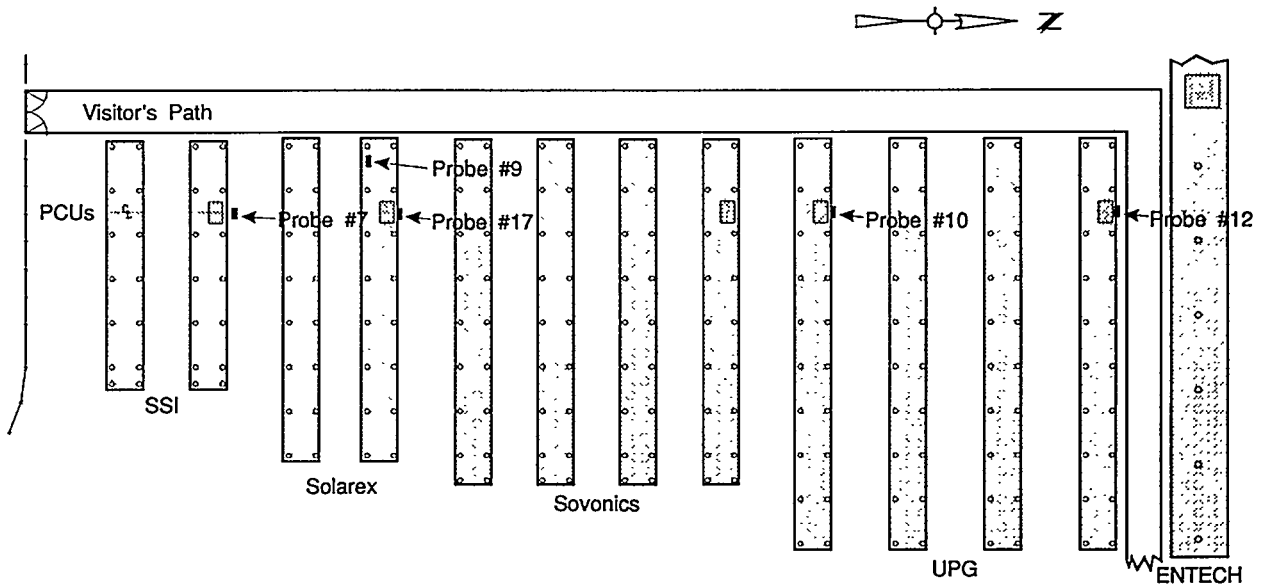

Figure 3-14. Magnetic field contour plot in the SSI US-1 area (STAR/VANA), Davis.



| Probe No. | Measurement Location |
|-----------|--|
| 7 | By SSI PCU, 19" above ground, against PCU face |
| 17 | By Solarex PCU, 19" above ground, against PCU face |
| 9 | 23" from Solarex PCU, 19" above ground |
| 10 | By UPG PCU, 19" above ground, against PCU face |
| 12 | By ENTECH PCU, 19" above ground, against PCU face |

11:55 a.m. to 12:00 p.m.

| Frequency (Hz) | Probe #7 | | Probe #17 | | Probe #9 | | Probe #10 | | Probe #12 | |
|-------------------|---------------|---------|---------------|---------|---------------|---------|---------------|---------|---------------|---------|
| | Field (mG) | % Fund. | Field (mG) | % Fund. | Field (mG) | % Fund. | Field (mG) | % Fund. | Field (mG) | % Fund. |
| 60 | 225.34 | 100.00 | 175.96 | 100.00 | 0.04 | 100.00 | 225.57 | 100.00 | 190.22 | 100.00 |
| 120 | 17.48 | 7.76 | 1.12 | 0.63 | 0.00 | 0.75 | 5.89 | 2.61 | 14.44 | 7.59 |
| 180 | 10.58 | 4.70 | 2.15 | 1.22 | 0.02 | 5.26 | 4.01 | 1.78 | 5.49 | 2.89 |
| 240 | 5.87 | 2.61 | 0.17 | 0.09 | 0.00 | 0.25 | 1.61 | 0.71 | 2.61 | 1.37 |
| 300 | 3.40 | 1.51 | 3.07 | 1.74 | 0.01 | 3.01 | 2.60 | 1.15 | 3.55 | 1.87 |
| 360 | 4.34 | 1.93 | 0.14 | 0.08 | 0.00 | 0.50 | 1.01 | 0.45 | 1.25 | 0.66 |
| 420 | 4.80 | 2.13 | 1.46 | 0.83 | 0.01 | 2.01 | 1.62 | 0.72 | 4.06 | 2.13 |
| 480 | 4.66 | 2.07 | 0.30 | 0.17 | 0.00 | 0.05 | 1.30 | 0.58 | 1.52 | 0.80 |
| 540 | 4.37 | 1.94 | 0.43 | 0.24 | 0.01 | 1.75 | 0.89 | 0.84 | 1.18 | 0.62 |
| 600 | 0.98 | 0.43 | 0.05 | 0.03 | 0.00 | 0.00 | 0.68 | 0.30 | 1.10 | 0.58 |
| 660 | 3.76 | 1.67 | 0.47 | 0.27 | 0.01 | 2.76 | 5.39 | 2.39 | 2.22 | 1.16 |
| 720 | 0.44 | 0.19 | 0.04 | 0.02 | 0.00 | 0.00 | 0.19 | 0.08 | 0.18 | 0.09 |
| 780 | 1.60 | 0.71 | 0.57 | 0.32 | 0.00 | 0.75 | 2.90 | 1.29 | 0.81 | 0.42 |

Figure 3-15. MultiWave frequency analysis of Davis EMT-1, Dataset 1.

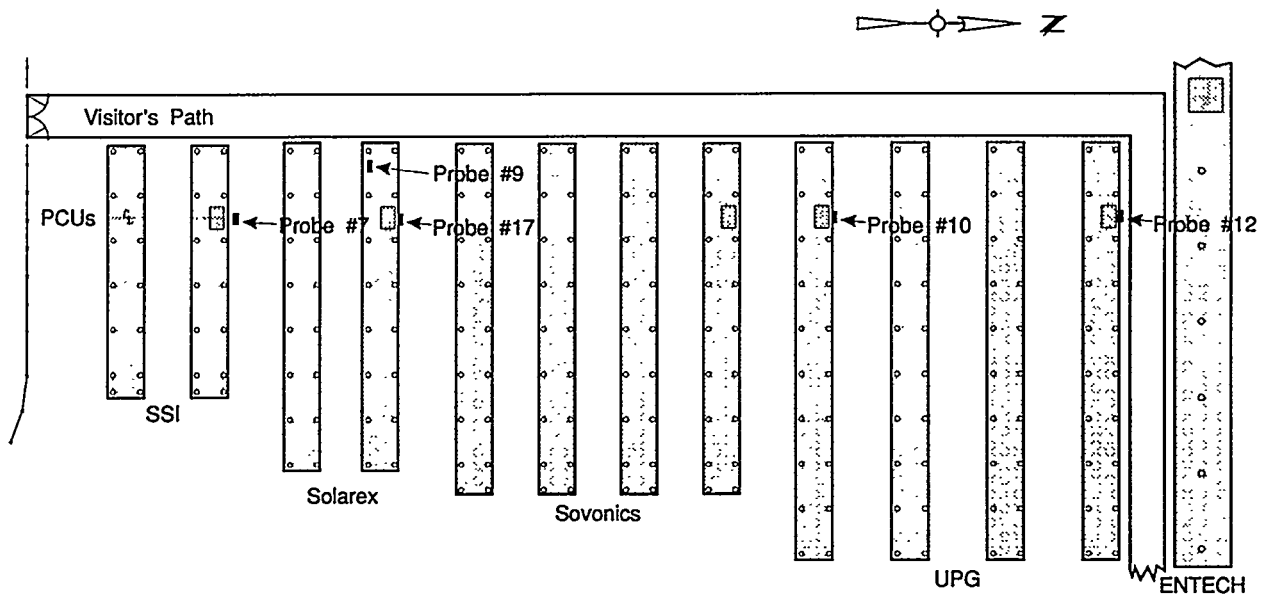

| Probe No. | Measurement Location |
|-----------|--|
| 7 | By SSI PCU, 19" above ground, against PCU face |
| 17 | By Solarex PCU, 19" above ground, against PCU face |
| 9 | 23" from Solarex PCU, 19" above ground |
| 10 | By UPG PCU, 19" above ground, against PCU face |
| 12 | By ENTECH PCU, 19" above ground, against PCU face |

1:50 to 1:55 p.m.

| Frequency (Hz) | Probe #7 | | Probe #17 | | Probe #9 | | Probe #10 | | Probe #12 | |
|-------------------|---------------|---------|---------------|---------|---------------|---------|---------------|---------|---------------|---------|
| | Field (mG) | % Fund. | Field (mG) | % Fund. | Field (mG) | % Fund. | Field (mG) | % Fund. | Field (mG) | % Fund. |
| 60 | 236.24 | 100.00 | 181.26 | 100.00 | 0.43 | 100.00 | 252.88 | 100.00 | 205.04 | 100.00 |
| 120 | 23.63 | 10.00 | 0.86 | 0.47 | 0.00 | 0.93 | 35.44 | 14.01 | 20.92 | 10.20 |
| 180 | 14.33 | 6.06 | 2.38 | 1.31 | 0.02 | 5.61 | 12.06 | 4.77 | 4.86 | 4.13 |
| 240 | 7.51 | 3.18 | 0.09 | 0.05 | 0.00 | 0.70 | 9.56 | 3.78 | 4.09 | 1.99 |
| 300 | 3.72 | 1.58 | 2.97 | 1.64 | 0.01 | 2.57 | 6.24 | 2.47 | 4.76 | 2.32 |
| 360 | 5.89 | 2.49 | 0.09 | 0.05 | 0.01 | 1.17 | 4.92 | 1.95 | 1.82 | 0.89 |
| 420 | 6.28 | 2.66 | 1.30 | 0.72 | 0.01 | 2.57 | 8.71 | 3.44 | 5.28 | 2.57 |
| 480 | 5.96 | 2.52 | 0.30 | 0.17 | 0.01 | 1.87 | 5.44 | 2.15 | 2.46 | 1.20 |
| 540 | 4.93 | 2.09 | 0.39 | 0.22 | 0.01 | 2.10 | 2.64 | 1.04 | 1.98 | 0.96 |
| 600 | 1.19 | 0.50 | 0.05 | 0.03 | 0.00 | 0.23 | 1.06 | 0.42 | 1.90 | 0.93 |
| 660 | 4.43 | 1.87 | 0.98 | 0.54 | 0.02 | 3.50 | 6.20 | 2.45 | 2.81 | 1.37 |
| 720 | 0.55 | 0.23 | 0.03 | 0.02 | 0.00 | 0.00 | 0.90 | 0.36 | 0.41 | 0.20 |
| 780 | 2.14 | 0.91 | 0.28 | 0.15 | 0.00 | 0.93 | 3.76 | 1.48 | 0.93 | 0.45 |

Figure 3-16. MultiWave frequency analysis of Davis EMT-1, Dataset 2.

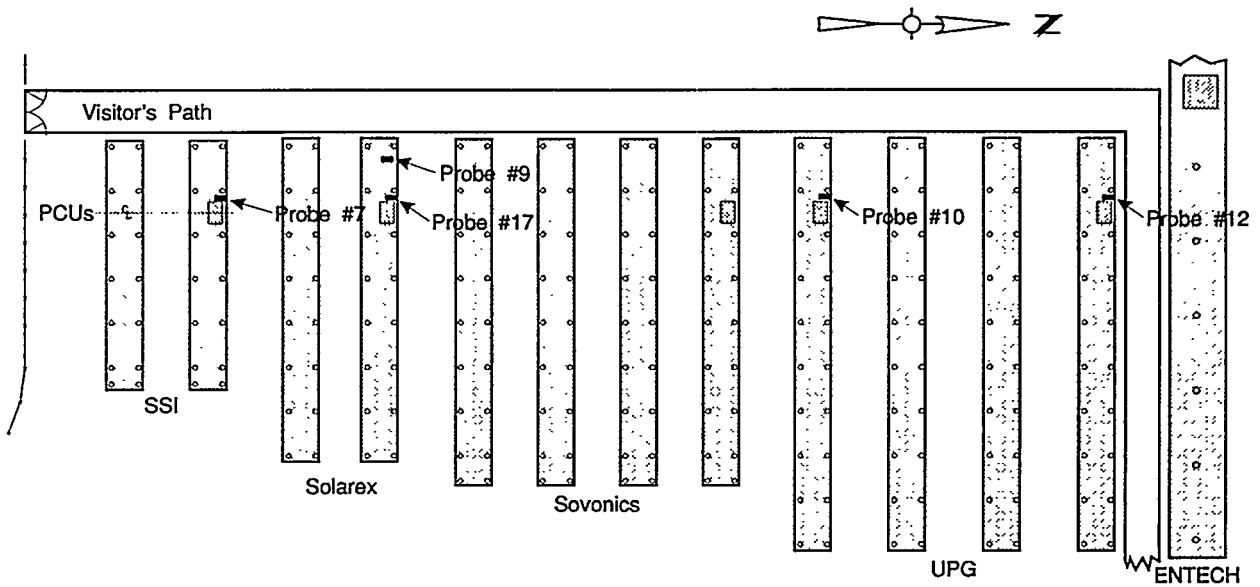

| Probe No. | Measurement Location |
|-----------|--|
| 7 | By SSI PCU, on pad by power conduit |
| 17 | By Solarex PCU, on pad by power conduit |
| 9 | Against Solarex PV panel, 51" above ground |
| 10 | By UPG PCU, on pad by power conduit |
| 12 | By ENTECH PCU, on pad by power conduit |

2:08 to 2:15 p.m.

| Frequency (Hz) | Probe #7 | | Probe #17 | | Probe #9 | | Probe #10 | | Probe #12 | |
|-------------------|---------------|---------|---------------|---------|---------------|---------|---------------|---------|---------------|---------|
| | Field (mG) | % Fund. | Field (mG) | % Fund. | Field (mG) | % Fund. | Field (mG) | % Fund. | Field (mG) | % Fund. |
| 60 | 76.53 | 100.00 | 63.39 | 100.00 | 0.20 | 100.00 | 45.79 | 100.00 | 36.24 | 100.00 |
| 120 | 9.05 | 11.82 | 0.21 | 0.33 | 0.03 | 14.57 | 0.42 | 0.91 | 3.78 | 10.44 |
| 180 | 4.24 | 5.54 | 1.02 | 1.61 | 0.01 | 5.03 | 1.37 | 3.00 | 1.91 | 5.26 |
| 240 | 2.13 | 2.78 | 0.07 | 0.12 | 0.00 | 2.01 | 0.27 | 0.59 | 1.08 | 2.97 |
| 300 | 2.42 | 3.17 | 1.04 | 1.64 | 0.01 | 4.02 | 1.24 | 2.71 | 1.00 | 2.75 |
| 360 | 1.93 | 2.52 | 0.11 | 0.18 | 0.01 | 7.04 | 0.29 | 0.64 | 0.34 | 0.93 |
| 420 | 1.61 | 2.11 | 0.79 | 1.24 | 0.01 | 3.52 | 0.65 | 1.41 | 0.91 | 2.51 |
| 480 | 1.91 | 2.50 | 0.27 | 0.43 | 0.01 | 3.52 | 0.49 | 1.08 | 0.75 | 2.08 |
| 540 | 2.11 | 2.76 | 0.70 | 1.11 | 0.01 | 2.51 | 0.63 | 1.37 | 0.41 | 1.14 |
| 600 | 0.18 | 0.23 | 0.03 | 0.04 | 0.00 | 0.50 | 0.09 | 0.19 | 0.39 | 1.07 |
| 660 | 3.08 | 4.02 | 1.29 | 2.03 | 0.01 | 4.52 | 2.52 | 5.49 | 1.22 | 3.36 |
| 720 | 0.16 | 0.20 | 0.02 | 0.03 | 0.01 | 3.02 | 0.05 | 0.10 | 0.03 | 0.09 |
| 780 | 1.25 | 1.63 | 0.46 | 0.73 | 0.00 | 1.51 | 0.83 | 1.81 | 0.51 | 1.41 |

Figure 3-17. MultiWave frequency analysis of Davis EMT-1, Dataset 3.

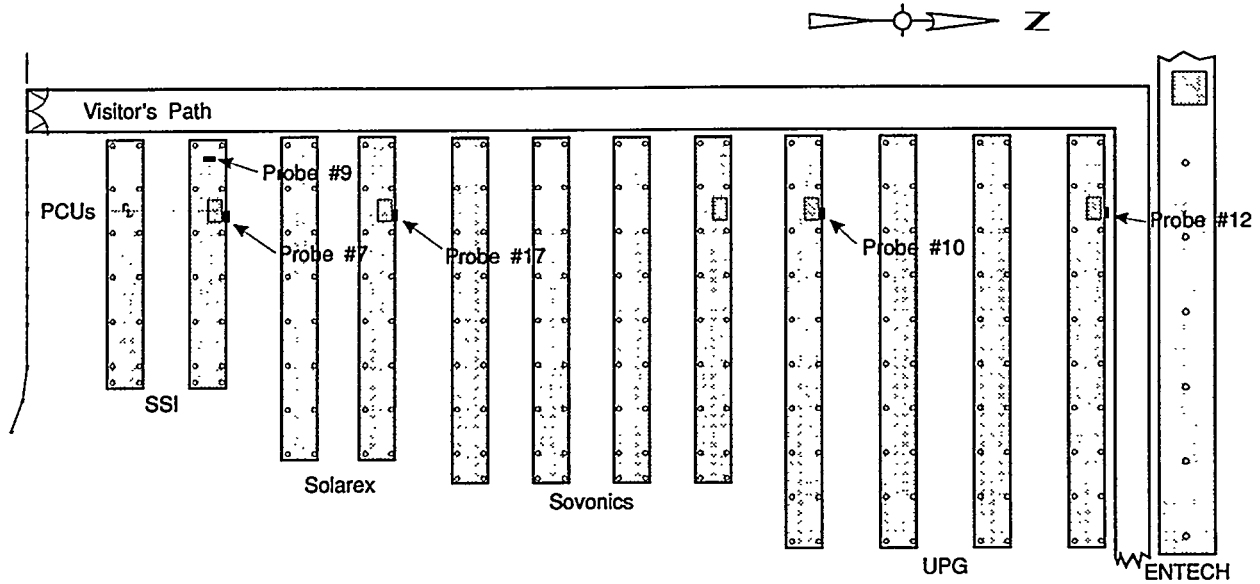

| Probe No. | Measurement Location |
|-----------|---|
| 7 | By SSI PCU, 19" above ground, 16" from RDU |
| 17 | By Solarex PCU, 19" above ground, 16" from RDU |
| 9 | Against SSI PV Panel, 2" from jumper wire, 62" above ground |
| 10 | By UPG PCU, on pad by power conduit |
| 12 | By ENTECH PCU, on pad by power conduit |

2:08 to 2:15 p.m.

| Frequency (Hz) | Probe #7 | | Probe #17 | | Probe #9 | | Probe #10 | | Probe #12 | |
|----------------|------------|---------|------------|---------|------------|---------|------------|---------|------------|---------|
| | Field (mG) | % Fund. | Field (mG) | % Fund. | Field (mG) | % Fund. | Field (mG) | % Fund. | Field (mG) | % Fund. |
| 60 | 13.15 | 100.00 | 9.25 | 100.00 | 0.88 | 100.00 | 10.60 | 100.00 | 19.96 | 100.00 |
| 120 | 2.86 | 21.74 | 0.05 | 0.53 | 0.35 | 39.77 | 0.28 | 2.65 | 0.74 | 3.70 |
| 180 | 1.80 | 13.72 | 0.10 | 1.07 | 0.04 | 4.77 | 0.20 | 1.84 | 0.58 | 2.91 |
| 240 | 1.00 | 7.58 | 0.02 | 0.18 | 0.08 | 8.52 | 0.08 | 0.76 | 0.26 | 1.32 |
| 300 | 0.27 | 2.05 | 0.30 | 3.26 | 0.09 | 10.23 | 0.37 | 3.45 | 0.47 | 2.37 |
| 360 | 0.75 | 5.74 | 0.02 | 0.22 | 0.19 | 21.02 | 0.08 | 0.75 | 0.17 | 0.84 |
| 420 | 0.68 | 5.13 | 0.25 | 2.75 | 0.24 | 27.39 | 0.18 | 1.67 | 0.60 | 3.02 |
| 480 | 0.84 | 6.42 | 0.04 | 0.46 | 0.22 | 25.11 | 0.10 | 0.93 | 0.19 | 0.97 |
| 540 | 0.76 | 5.81 | 0.13 | 1.45 | 0.03 | 3.75 | 0.24 | 2.30 | 0.28 | 1.40 |
| 600 | 0.17 | 1.32 | 0.01 | 0.11 | 0.04 | 3.98 | 0.05 | 0.48 | 0.12 | 0.71 |
| 660 | 0.66 | 5.01 | 0.15 | 1.59 | 0.02 | 1.93 | 0.82 | 7.76 | 0.83 | 4.16 |
| 720 | 0.10 | 0.76 | 0.00 | 0.04 | 0.15 | 16.93 | 0.03 | 0.31 | 0.08 | 0.39 |
| 780 | 0.28 | 2.11 | 0.02 | 0.23 | 0.01 | 1.36 | 0.41 | 3.89 | 0.35 | 1.73 |

Figure 3-18. MultiWave frequency analysis of Davis EMT-1, Dataset 4.

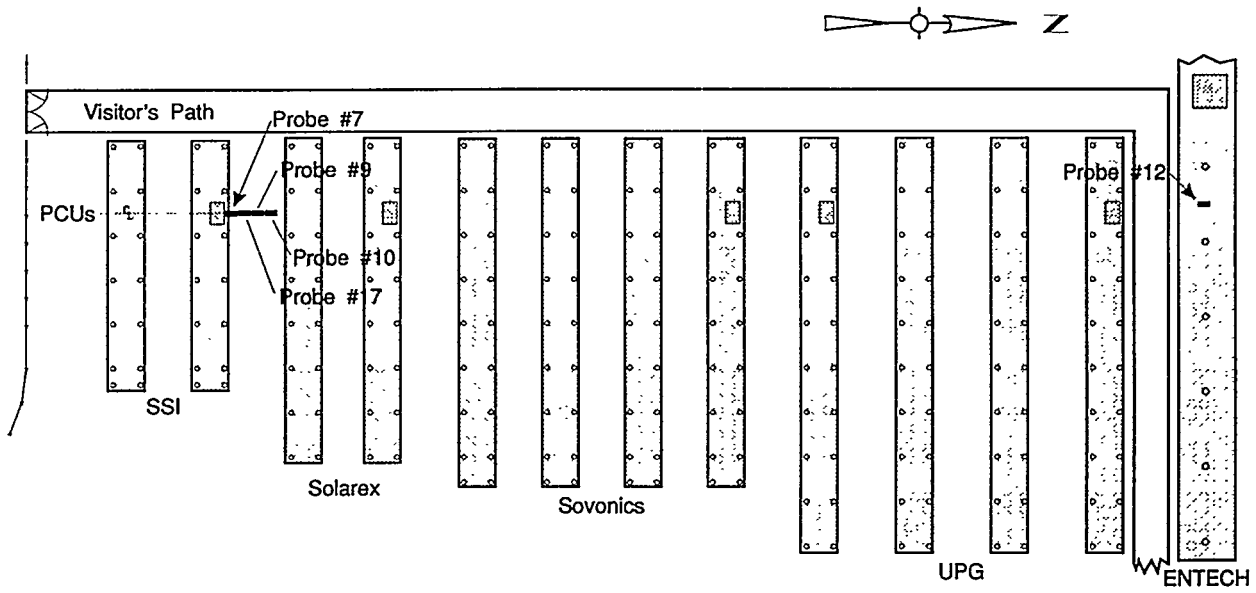

| Probe No. | Measurement Location |
|-----------|---|
| 7 | By SSI PCU, 19" above ground, 1' from face |
| 17 | By SSI PCU, 19" above ground, 2' from face |
| 9 | By SSI PCU, 19" above ground, 3' from face |
| 10 | By SSI PCU, 19" above ground, 4' from face |
| 12 | By ENTECH PV module, under heatfins, 67" above ground |

3:10 to 3:15 p.m.

| Frequency (Hz) | Probe #7 | | Probe #17 | | Probe #9 | | Probe #10 | | Probe #12 | |
|----------------|------------|---------|------------|---------|------------|---------|------------|---------|------------|---------|
| | Field (mG) | % Fund. | Field (mG) | % Fund. | Field (mG) | % Fund. | Field (mG) | % Fund. | Field (mG) | % Fund. |
| 60 | 79.70 | 100.00 | 26.87 | 100.00 | 12.42 | 100.00 | 6.08 | 100.00 | 0.53 | 100.00 |
| 120 | 1.87 | 2.35 | 0.64 | 2.40 | 0.24 | 1.96 | 0.13 | 2.09 | 0.28 | 52.26 |
| 180 | 1.36 | 1.71 | 0.50 | 1.87 | 0.23 | 1.82 | 0.12 | 1.91 | 0.04 | 7.52 |
| 240 | 1.02 | 1.28 | 0.43 | 1.61 | 0.17 | 1.36 | 0.09 | 1.51 | 0.04 | 8.08 |
| 300 | 1.59 | 1.99 | 0.68 | 2.52 | 0.36 | 2.86 | 0.22 | 3.63 | 0.04 | 6.58 |
| 360 | 0.64 | 0.80 | 0.25 | 0.93 | 0.10 | 0.83 | 0.06 | 0.99 | 0.08 | 15.60 |
| 420 | 1.54 | 1.93 | 0.75 | 2.78 | 0.45 | 3.63 | 0.24 | 3.88 | 0.16 | 29.32 |
| 480 | 0.56 | 0.70 | 0.22 | 0.82 | 0.10 | 0.82 | 0.06 | 0.94 | 0.02 | 3.57 |
| 540 | 2.32 | 2.91 | 1.03 | 3.84 | 0.28 | 2.28 | 0.12 | 1.91 | 0.02 | 3.38 |
| 600 | 0.29 | 0.37 | 0.13 | 0.48 | 0.05 | 0.43 | 0.02 | 0.39 | 0.02 | 3.01 |
| 660 | 3.30 | 4.15 | 1.47 | 5.46 | 0.63 | 5.05 | 0.32 | 5.31 | 0.01 | 2.44 |
| 720 | 0.07 | 0.09 | 0.03 | 0.11 | 0.01 | 0.11 | 0.01 | 0.10 | 0.07 | 13.72 |
| 780 | 1.56 | 1.95 | 0.68 | 2.55 | 0.30 | 2.38 | 0.17 | 2.73 | 0.01 | 0.94 |

Figure 3-19. MultiWave frequency analysis of Davis EMT-1, Dataset 5.

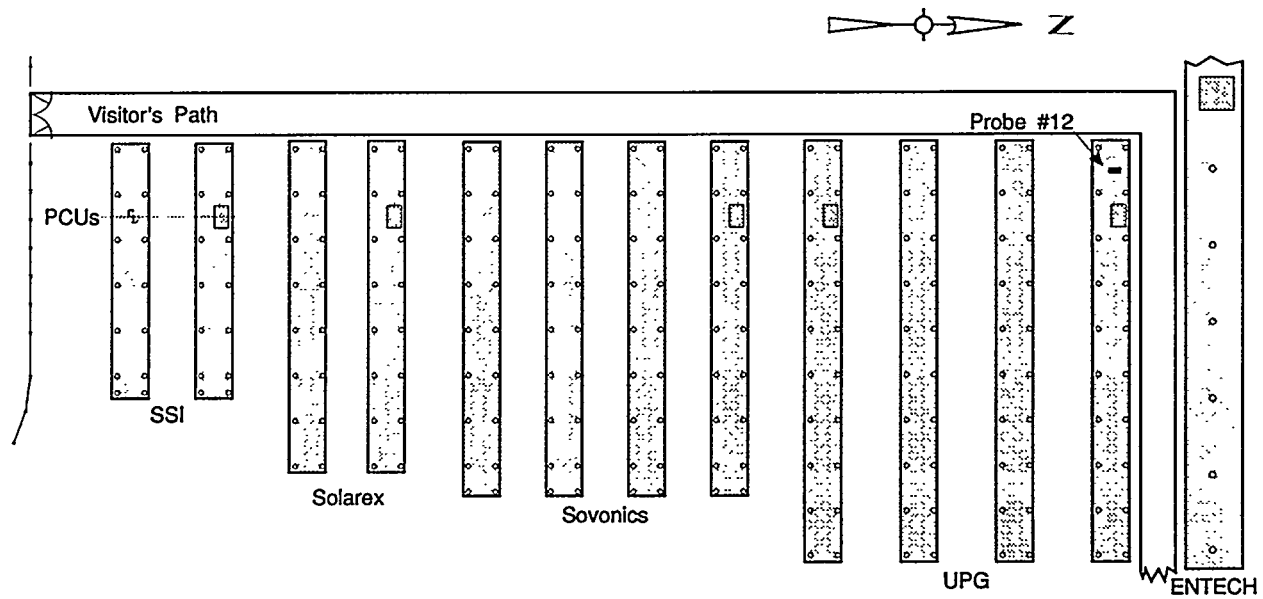

| Probe No. | Measurement Location |
|-----------|-----------------------------------|
| 12 | By UPG PV panel, 76" above ground |

3:31 to 3:36 p.m.

| Frequency (Hz) | Probe #12 | |
|----------------|-----------|--------|
| 60 | 0.53 | 100.00 |
| 120 | 0.10 | 18.08 |
| 180 | 0.04 | 6.59 |
| 240 | 0.01 | 1.51 |
| 300 | 0.03 | 5.46 |
| 360 | 0.05 | 9.42 |
| 420 | 0.02 | 4.52 |
| 480 | 0.05 | 9.60 |
| 540 | 0.02 | 3.01 |
| 600 | 0.01 | 1.32 |
| 660 | 0.04 | 6.78 |
| 720 | 0.03 | 6.40 |
| 780 | 0.02 | 3.20 |

Figure 3-20. MultiWave frequency analysis of Davis EMT-1, Dataset 6.

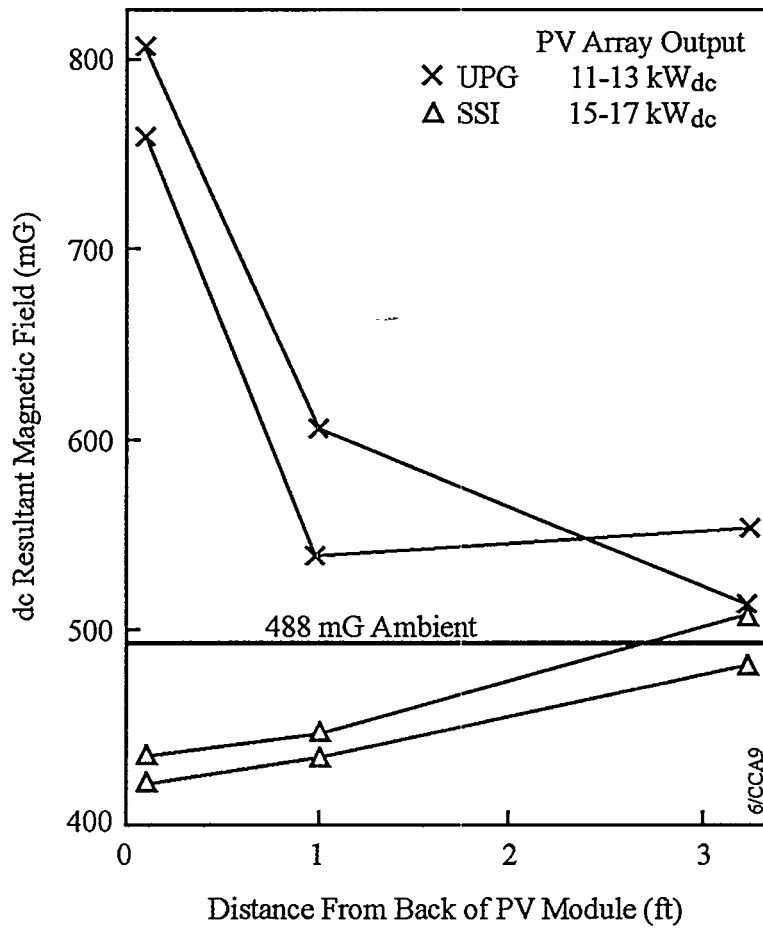

Figure 3-21. DC magnetic fields near PVUSA Davis EMT-1 PV arrays.

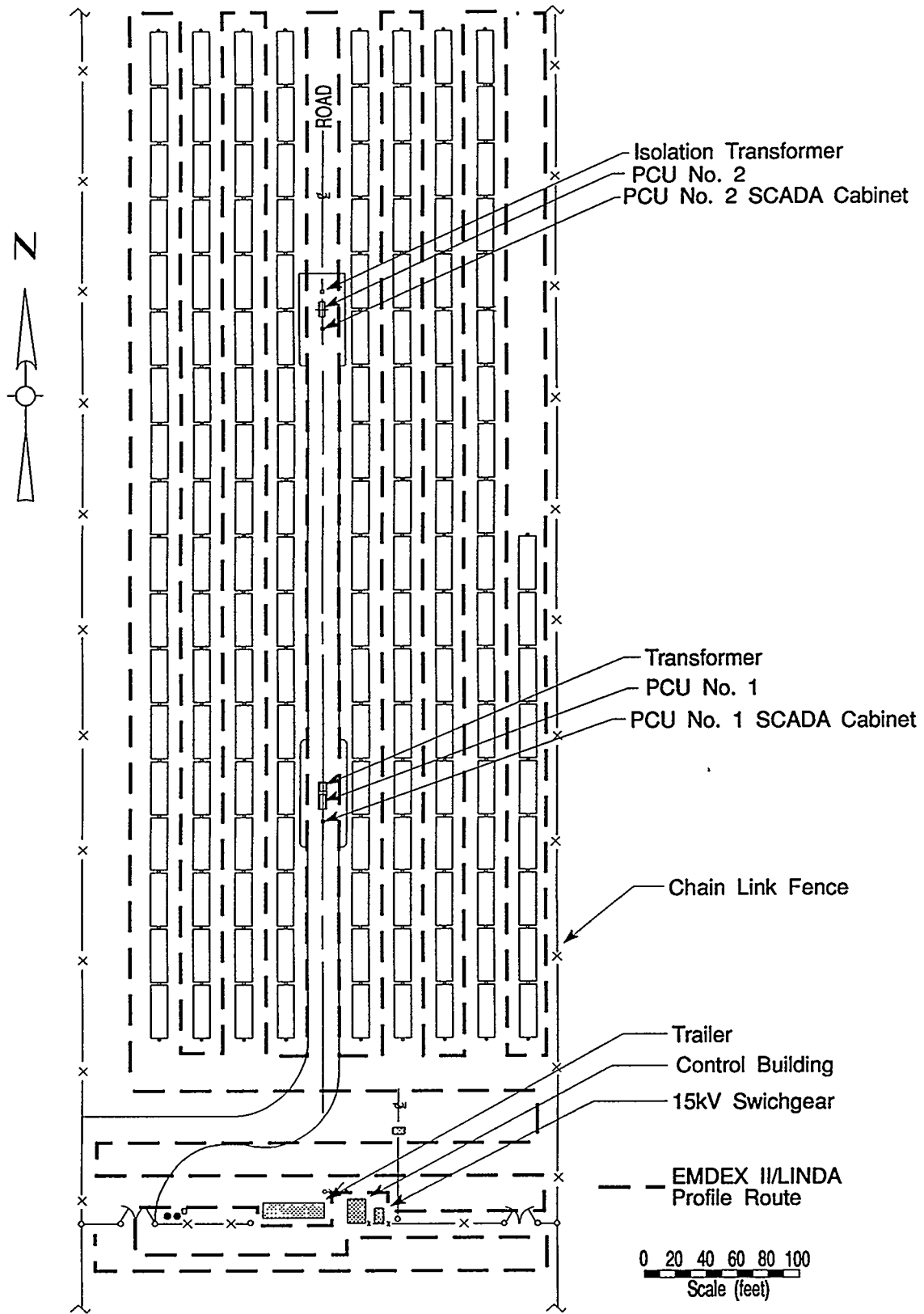

Figure 3-22. General arrangement and profile map at Kerman.

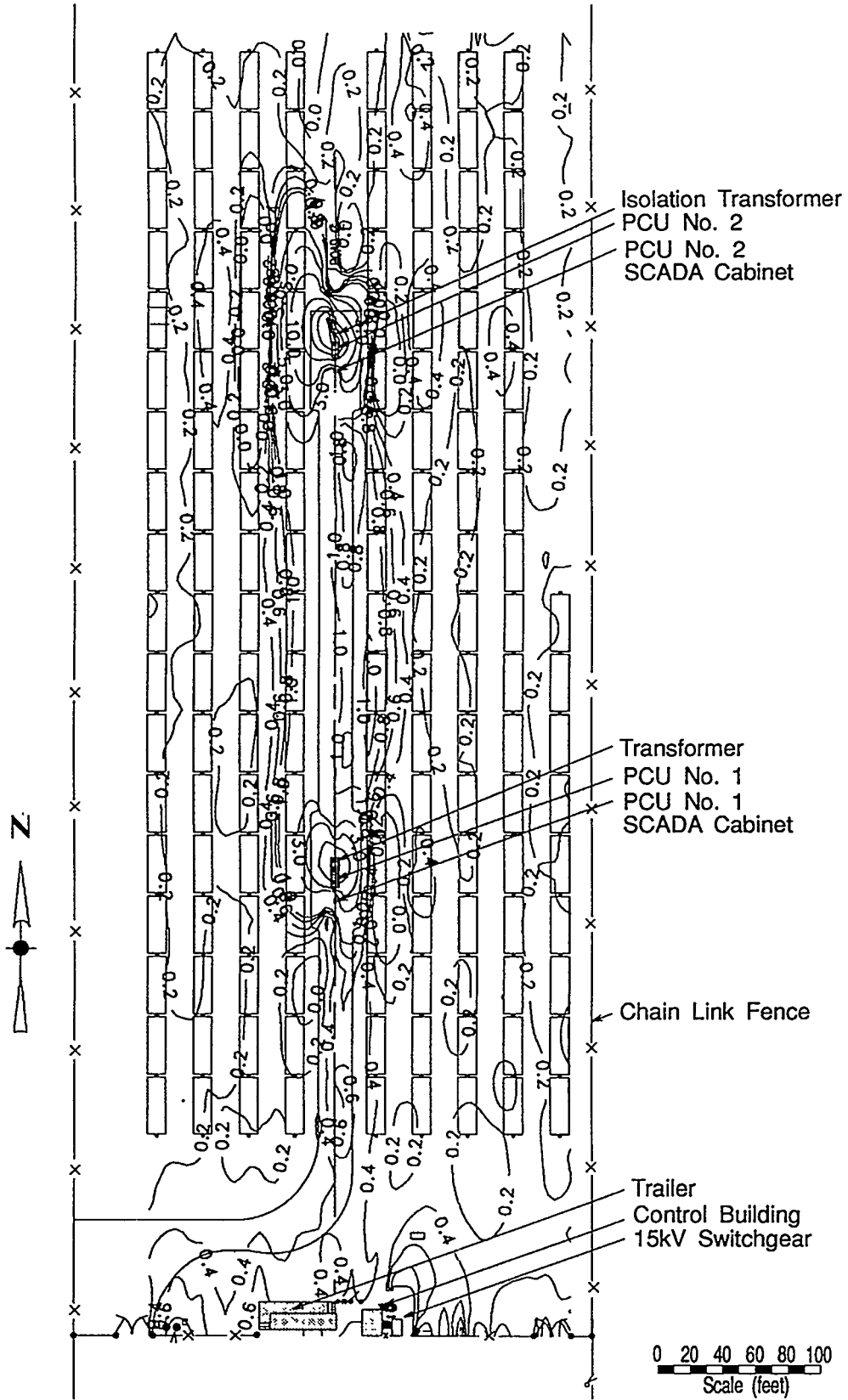

Figure 3-23. Magnetic field contour plot at Kerman.

Section 4

DISCUSSION

Magnetic field intensity depends on the amount of current, the configuration of the current sources, and the direction of the currents. For a given conductor, magnetic field intensity increases with increasing current flow. If two parallel conductors have currents flowing in opposite directions, the magnetic field created by current flowing in one direction may be largely canceled out by the magnetic field created by current flowing in the opposite direction. Magnetic fields may be reduced by using shielding materials or configuring the current flows to maximize field cancellation. However, increases in installed system costs, line losses, and maintenance costs due to system complexity should also be taken into consideration if minimizing PV system EMF is necessary.

DAVIS EMT-1 AREA

Profile plots taken with STAR (Figures 3-5 and 3-6) indicate that the maximum magnetic field levels occur near the PCU stations, with the highest reading near the ENTECH PCU.

The SSI EMT-1 array produced a wide range of significant harmonic magnetic fields (Figure 3-18, Probe #9). Although the fundamental field (60 Hz) is below 1 mG, it produced notable fields in the 2nd, 7th, 8th, 9th, and 12th harmonics (120, 420, 480, 540, and 720 Hz, respectively). The ENTECH array (Figure 3-19, Probe #12) has significant 2nd, 6th, 7th, and 12th harmonics (120, 360, 420, and 720 Hz, respectively). The Solarex and UPG arrays indicate only a significant 2nd harmonic. These harmonic field levels are indicative of the frequency-modulated signals produced by the PCUs.

Figure 4-1 presents 60-Hz magnetic fields measured as close as possible to the back of the EMT-1 PV modules and compares them to magnetic fields near household appliances selected from Gauger (1985). Magnetic fields produced at the back of the PV modules produce lower fields than common household appliances.

PV DC magnetic fields augment (as for UPG) or counteract (as for SSI) the earth's fields, depending on the array design (see Figure 3-21). The metal backing attached to the UPG modules enhances the DC magnetic field. The PV DC field intensities decrease with increasing distance. At about 3 feet from the modules, the DC field approximates the ambient DC magnetic field level.

DAVIS US-1 AREA

High magnetic field sources appear near the APS PCU and transformer areas. In the SSI US-1 region, the higher magnetic sources are near the transformer and switchgear. As shown in Figures 3-11 to 3-14,

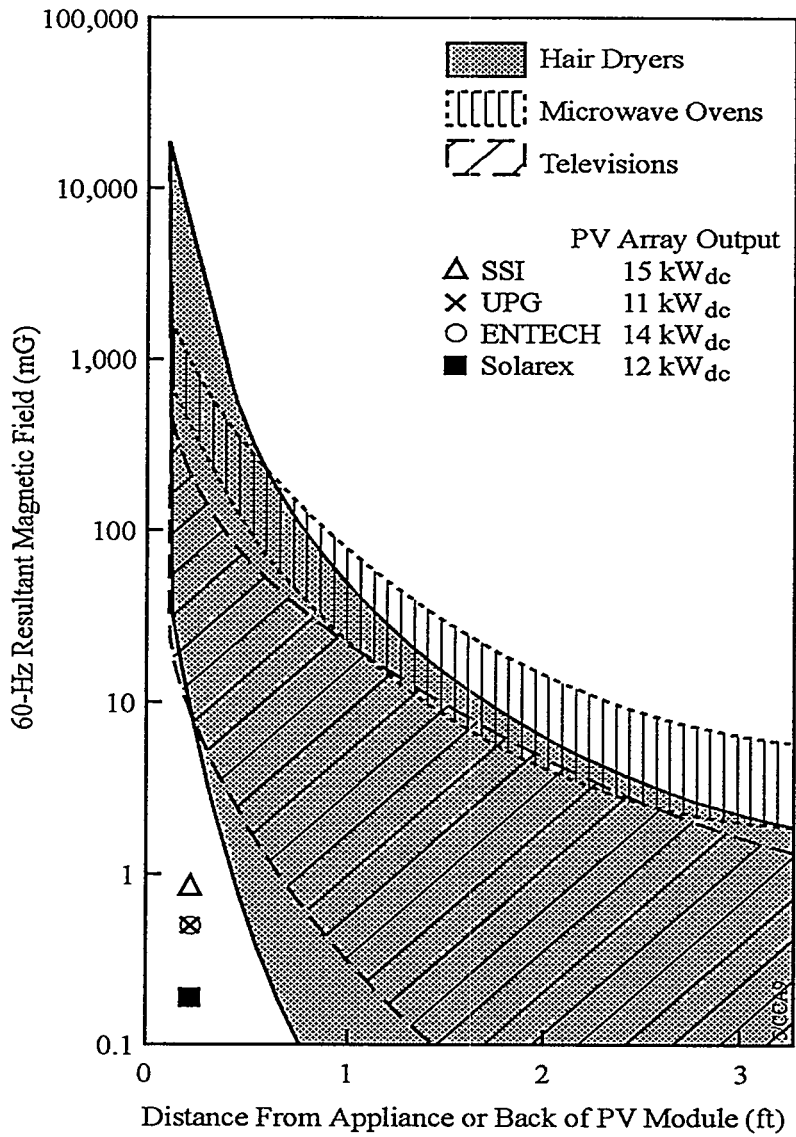

Figure 4-1. Comparison of back-of-module magnetic field measurements.

the STAR/VANA unit measures lower overall fields than the EMDEX II/LINDA unit: the frequency range for STAR/VANA is 60-Hz, whereas it is 40 to 800 Hz for the EMDEX II/LINDA unit. However, the contour lines are similar.

KERMAN

The higher magnetic field sources appear in the vicinity of PCU No. 2 (Figure 3-22). The arrangement is similar to the SSI US-1 system.

Section 5

CONCLUSIONS

The data documented in this report address PG&E's EMF policy and may be helpful to the PV industry in responding to potential public and utility concerns about PV EMF. Although not comprehensive, EMF data taken at PVUSA indicate that 60-Hz magnetic fields (the EMF type of greatest public concern) are significantly less for PV arrays than for household appliances. Therefore, given the present EMF research knowledge, PV array EMF may not merit considerable concern. The PV system components exhibiting significant AC magnetic fields are the transformers and PCUs. However, the AC magnetic fields associated with these components are localized and are not detected at PV system perimeters. Concern about transformer and PCU EMF would apply to several generation and storage technologies.

Section 6

REFERENCES

- Dietrich, F. M., W. E. Feero, D. C. Robertson, and R. M. Sicree. 1992. *Measurement of Power System Magnetic Fields by Waveform Capture*. EPRI Report TR-100061, Electric Power Research Institute, Palo Alto, California.
- Gauger, J. R. 1985. "Household Appliance Magnetic Field Survey." *IEEE Transactions on Power Apparatus and Systems*, Vol. PAS-104.
- Jennings, C., G. Chang, and G. K. Bell. 1993. "PV EMF." Paper presented at the 23rd IEEE Photovoltaic Specialists Conference, Louisville, Kentucky.
- Silva, J. M. 1991. *EMDEX II EPRI Electric and Magnetic Field Digital Exposure System User Manual*.