

DISTRIBUTION SHEET

To	From	Page 1 of 1
Distribution	Fuel Supply Shutdown	Date 5/19/95
Project Title/Work Order		EDT No. 141813
WHC-SD-NR-ISB-001, Rev. 0/Interim Safety Basis for Fuel Supply Shutdown Facility/K32FP		ECN No. N/A

Name	MSIN	Text With All Attach.	Text Only	Attach./Appendix Only	EDT/ECN Only
M. W. Benecke	L6-26		X		
R. L. Besser	H4-65		X		
J. R. Brehm	H4-68		X		
R. J. Cash	R2-78		X		
A. M. Horner (2 copies)	L6-57		X		
L. E. Johnson	H4-68		X		
I. L. Metcalf	L6-26		X		
D. E. Rasmussen	N1-47		X		
A. B. Rau	H4-68		X		
J. A. Remaize	L6-26		X		
M. E. Riste	N1-71		X		
J. M. Steffen	N1-47		X		
Central Files (2 copies)	L8-04		X		
Docket Files (2 copies)	H5-36		X		
OSTI (2 copies)	L8-07		X		

DISCLAIMER

Portions of this document may be illegible in electronic image products. Images are produced from the best available original document.

5

sta. 4
MAY 23 1995

ENGINEERING DATA TRANSMITTAL

Page 1 of 1
1. EDT No. 141813

2. To: (Receiving Organization) Distribution	3. From: (Originating Organization) Project Safety Engineering	4. Related EDT No.: 142430
5. Proj./Prog./Dept./Div.: N Fuels	6. Cog. Engr.: J. R. Brehm, 376-8602, H4-68	7. Purchase Order No.: N/A
8. Originator Remarks: The attached document is distributed for final approval.		9. Equip./Component No.: N/A
11. Receiver Remarks: <i>This document is approved for public release.</i>		10. System/Bldg./Facility: Fuel Supply Shutdown Facility
		12. Major Assm. Dwg. No.: N/A
		13. Permit/Permit Application No.: N/A
		14. Required Response Date: February 28, 1995

15. DATA TRANSMITTED					(F)	(G)	(H)	(I)
(A) Item No.	(B) Document/Drawing No.	(C) Sheet No.	(D) Rev. No.	(E) Title or Description of Data Transmitted	Impact Level	Reason for Transmittal	Originator Disposition	Receiver Disposition
1	WHC-SD-NR-ISB-001	N/A	0	Interim Safety Basis For Fuel Supply Shutdown Facility	SQD	1	1	

16. KEY					
Impact Level (F)		Reason for Transmittal (G)		Disposition (H) & (I)	
1, 2, 3, or 4 (see MRP 5.43)		1. Approval 2. Release 3. Information	4. Review 5. Post-Review 6. Dist. (Receipt Acknow. Required)	1. Approved 2. Approved w/comment 3. Disapproved w/comment	4. Reviewed no/comment 5. Reviewed w/comment 6. Receipt acknowledged

17. SIGNATURE/DISTRIBUTION (See Impact Level for required signatures)											
(G)	(H)	(J) Name (K) Signature (L) Date (M) MSIN				(J) Name (K) Signature (L) Date (M) MSIN				(G)	(H)
Reason	Disp.									Reason	Disp.
1	/	Cog. Eng. J. R. Brehm	<i>J. Brehm</i>	02-27-95	H4-68	SEAC R. J. Cash	<i>R. Cash</i>	3/1/95	S7-15	1	1
1	/	Cog. Mgr. L. E. Johnson	<i>L. E. Johnson</i>	2-27-95	H4-68						
1	/	QA M. E. Riste	<i>M. Riste</i>	2/28/95	N1-71						
1	/	Safety E. J. Krejca	<i>E. Krejca</i>	2/28/95	N1-72						
1	/	Fuel Supply I. L. Metcal	<i>I. Metcal</i>	2/28/95							

18. Signature of EDT Originator <i>J. Brehm</i> Date: 2-27-95	19. Authorized Representative for Receiving Organization <i>L. Johnson</i> Date: 5/16/95	20. Cognizant/Project Engineer's Manager <i>R. Cash</i> Date: 2/27/95	21. DOE APPROVAL (if required) Ltr. No. 9502417 <input checked="" type="checkbox"/> Approved <input type="checkbox"/> Approved w/comments <input type="checkbox"/> Disapproved w/comments
---	--	---	---

BD-7400-172-2 (07/91) GEF097

BD-7400-172-1 (07/91)

RELEASE AUTHORIZATION

Document Number: WHC-SD-NR-ISB-001, Rev. 0

Document Title: INTERIM SAFETY BASIS FOR FUEL SUPPLY SHUTDOWN FACILITY

Release Date: 5/23/95

This document was reviewed following the procedures described in WHC-CM-3-4 and is:

APPROVED FOR PUBLIC RELEASE

WHC Information Release Administration Specialist:

Chris Willingham

C. Willingham

5/23/95

TRADEMARK DISCLAIMER. Reference herein to any specific commercial product, process, or service by trade name, trademark, manufacturer, or otherwise, does not necessarily constitute or imply its endorsement, recommendation, or favoring by the United States Government or any agency thereof or its contractors or subcontractors.

This report has been reproduced from the best available copy. Available in paper copy and microfiche. Printed in the United States of America. Available to the U.S. Department of Energy and its contractors from:

U.S. Department of Energy
Office of Scientific and Technical Information (OSTI)
P.O. Box 62
Oak Ridge, TN 37831
Telephone: (615) 576-8401

Available to the public from:

U.S. Department of Commerce
National Technical Information Service (NTIS)
5285 Port Royal Road
Springfield, VA 22161
Telephone: (703) 487-4650

SUPPORTING DOCUMENT

1. Total Pages 63

2. Title

Interim Safety Basis for Fuel Supply Shutdown Facility

3. Number

WHC-SD-NR-ISB-001

4. Rev No.

0

5. Key Words

Interim Safety Basis Evaluation, Hazard Analysis, N Reactor Fuel Fabricaion and Storage Facility

6. Author

Name: J. R. Brehm, T. L. Deobald, M. W. Benecke, J. A. Remaize

MW Benecke
Signature

Organization/Charge Code 19800/K32FP

7. Abstract

This ISB in conjunction with the new TSRs, will provide the required basis for interim operation or restrictions on interim operations and administrative controls for the Facility until a SAR is prepared in accordance with the new requirements.

It is concluded that the risk associated with the current operational mode of the Facility, uranium closure, clean up, and transition activities required for permanent closure, are within Risk Acceptance Guidelines. The Facility is classified as a Moderate Hazard Facility because of the potential for an unmitigated fire associated with the uranium storage buildings.

DISCLAIMER

This report was prepared as an account of work sponsored by an agency of the United States Government. Neither the United States Government nor any agency thereof, nor any of their employees, makes any warranty, express or implied, or assumes any legal liability or responsibility for the accuracy, completeness, or usefulness of any information, apparatus, product, or process disclosed, or represents that its use would not infringe privately owned rights. Reference herein to any specific commercial product, process, or service by trade name, trademark, manufacturer, or otherwise does not necessarily constitute or imply its endorsement, recommendation, or favoring by the United States Government or any agency thereof. The views and opinions of authors expressed herein do not necessarily state or reflect those of the United States Government or any agency thereof.

8. RELEASE STAMP

OFFICIAL RELEASE	5
BY WHC	
DATE	MAY 23 1995
	<i>Ala. 4</i>

WHC-SD-NR-ISB-001 REV 0

**INTERIM SAFETY BASIS FOR
FUEL SUPPLY SHUTDOWN FACILITY**

WESTINGHOUSE HANFORD COMPANY

April 1995

For the U.S. Department of Energy
Contract DE-AC06-87RL10930

This page intentionally left blank.

CONTENTS

1.0	INTRODUCTION AND SUMMARY	1
1.1	PURPOSE	1
1.2	STATUS OF FACILITY IMPROVEMENTS	1
1.3	SAFETY BASIS DOCUMENTATION UPGRADES	1
1.4	SUMMARY OF MANAGEMENT CONFIGURATION SYSTEMS	3
1.5	SUMMARY OF SAFETY ANALYSES	4
1.6	CONCLUSIONS	4
2.0	SITE, FACILITY, AND ORGANIZATION DESCRIPTION	5
2.1	HANFORD SITE AND 300 AREA DESCRIPTION	5
2.2	FUEL SUPPLY SHUTDOWN FACILITY	9
2.2.1	Background and Facility Description	9
2.2.2	Building Description, Construction, and Status	10
2.2.3	Current and Planned Operational Mode	27
2.2.4	Major Nuclear Facility Processes and Facility Segments	28
2.2.5	Facility Support Systems	28
2.2.6	Radioactive and Hazardous Wastes	29
2.2.7	Fuel Supply Shutdown Facility Organization	32
2.2.8	Principal Interfaces and Support	32
2.2.9	Facility Access Control	32
2.3	FACILITY FIRE PROTECTION	32
2.3.1	Facility Fire Protection	32
2.3.2	Hanford Fire Department	33
2.4	NEARBY FACILITIES AND ACTIVITIES	34
3.0	INTERIM SAFETY BASIS EVALUATION	36
3.1	HAZARD ANALYSIS	36
3.1.1	Hazard Categorization	36
3.1.2	Potential Accident Scenarios	37
3.1.3	Analysis of Significant Accidents/Events	37
3.1.4	Risks	43
3.2	HAZARD CONTROLS	43
3.2.1	Safety Structures, Systems and Components	43
3.2.2	Administrative Controls	44
3.2.3	Institutional Safety Programs	48
3.3	SUMMARY	48
4.0	HANFORD GENERIC AND FACILITY PROGRAMS	49
5.0	REFERENCES	53

LIST OF FIGURES

2.1-1.	Location of the Hanford Site.	6
2.1-2.	Features of the Hanford Site.	7
2.1-3.	Hanford 300 Area Detail.	8
2.2.2-1.	Facility Layout in the 300 Area.	15
2.2.2-2.	Fuel Supply Shutdown Facility Layout	16
2.2.2-3.	Buildings 303-A, 303-B, 303-E, and 303-G: Uranium Billet and Fuel Storage	17
2.2.2-4.	Building 303-F Pump House and 311 Tank Farm	18
2.2.2-5.	Building 303-K/3707-G: Mixed/Radioactive Solid Waste Storage/RCRA Closure	19
2.2.2-6.	Building 303-M: Uranium Oxide Facility	20
2.2.2-7.	Building 304: Waste Concretion	21
2.2.2-8.	Building 313: Manufacturing Support facility	22
2.2.2-9.	Building 333: Manufacturing Facility	23
2.2.2-10.	Building 333: Mezzanines	24
2.2.2-11.	Building 3712: Uranium Finished Fuel and Billet Storage	25
2.2.2-12.	Building 3716: Unfinished Uranium Fuel Storage	26
3.2.1-1.	Billet Storage and Shipment Box	45
3.2.1-2.	Fuel Scrap Storage and Shipment Box	46
3.2.1-3.	Finished Fuel Storage and Shipment Box	47

LIST OF TABLES

1.6-1.	Safety Class Exposure Limits, WHC-CM-1-3, MRP 5.46. (Safety Class 2 Offsite and Safety Class 3 Limits are Implied)	5
2.2.1-1.	Fuel Supply Shutdown Facility Building Identification, Current Function/Activity, and Hazard Category	10
2.2.6-1.	Facility Radiological Dose Rates and Contamination Levels. . .	31
3.1.1-1.	3712 Building Radionuclide Inventory Compared to Category 2 and Modified Category 2 Values	36
4.0-1.	Identification of Institutional Control or Safety Requirement, DOE Orders and Titles, WHC Control Manuals and Fuel Supply Shutdown-Specific Implementing Documentation	50

This page intentionally left blank.

**INTERIM SAFETY BASIS FOR FUEL
SUPPLY SHUTDOWN FACILITY**

1.0 INTRODUCTION AND SUMMARY

1.1 PURPOSE

This document establishes an interim safety basis (ISB) for the Fuel Supply Shutdown Facility (FSS) in accordance with the requirements of the Westinghouse Hanford Company (Westinghouse Hanford) manual WHC-CM-4-46, *Safety Analysis Manual*, Section 8.0, "Interim Safety Basis". Recent U.S. Department of Energy (DOE) Orders, DOE Order 5480.21, *Unreviewed Safety Questions (USQ)*, DOE Order 5480.22, *Technical Safety Requirements (TSR)*, and DOE Order 5480.23, *Nuclear Safety Analysis Reports (SAR)*, impose requirements to upgrade nuclear facility safety documentation.

This ISB and supporting analyses provide the required basis for the transitional activities identified for permanent closure of FSS. Also, the ISB and supporting analyses provide the authorization basis and safety envelope for consideration of USQ issues as defined in DOE Order 5480.21 and WHC-CM-1-3, *Management Requirements and Procedures*, MRP 5.12, "Identification and Resolution of Unreviewed Safety Questions."

1.2 STATUS OF FACILITY IMPROVEMENTS

The facility is currently undergoing transition activities required for permanent closure and transfer to the Decontamination and Decommission Program. In this context, improvements are measured in terms of progress made in implementing activities documented in a shutdown plan (Dawson 1994). The removal of bulk chemical inventories was completed in April 1991, and disposal of the unirradiated uranium inventory is in progress. Transfer of 326 metric tons of uranium (in the form of extrusion billets) to the United Kingdom was completed in December 1992, and activities associated with disposal and/or interim storage of the remaining inventory are continuing. Decontamination and waste disposal activities are also in progress.

1.3 SAFETY BASIS DOCUMENTATION UPGRADES

At the time of facility shutdown, applicable safety bases were limited. This ISB has been prepared to be responsive to the "Implementation Plan for DOE Orders 5480.21, 5480.22, and 5480.23," Reference Letter, J. M. Knoll, Westinghouse Hanford, to R. D. Larson, DOE Richland Field Office (RL), same subject, 9257875, dated October 28, 1992. The following safety analyses have been prepared to support this ISB and, together with this ISB, provide the safety envelope for FSS:

Facility Hazard Analysis (Johnson and Brehm 1994)

A facility hazard analysis has been prepared by a multi-disciplined team including representatives from FSS to identify hazards, energy sources, potential accidents and sequences, targets for potential accident consequences, available mitigating barriers, and qualitative accident severity levels. The most significant accidents are evaluated further in the accident safety analysis.

Accident Safety Analysis and Associated Dose Consequences (Johnson 1994)

Accident safety analysis scenarios have been analyzed based on the significant events identified in the facility hazard analysis (Johnson and Brehm 1994) and the fire hazard analysis (Myott 1994, 1995) using site specific meteorological conditions and analysis methodology. The results are summarized in Section 1.6.

Fire Hazards Analysis (Myott 1994, 1995)

Fire hazards analyses have been prepared that address FSS and associated fire and safety systems, the fire loading and potential fire exposure, fire systems, and Hanford Fire Department response to fires. These establish a basis for the accident safety analysis (Johnson 1994) and the fire criticality probability analysis (Kelly 1995).

Fire Criticality Probability Analysis (Kelly 1995)

This probability analysis shows that no credible accident scenario is postulated that could result in a criticality. Therefore, per DOE 5480.24, Nuclear Criticality Safety, a criticality detection and alarm system is not required.

Criticality Safety Evaluation Report for 300 Area Fissile Material Limits and Fuel Storage Technical Safety Requirements (Schwinkendorf 1995)

Criticality safety support calculations for FSS have been performed to update values currently found in the criticality prevention specifications. In addition, certain accident or upset conditions were analyzed. These scenarios include fire, the bringing together of multiple masses into one neutronically coupled system, mis-stacking, and accidental interspersed moderation.

Hazard Categorization (Brehm 1995)

A hazard categorization has been prepared for FSS in accordance with DOE-STD-1027-92, *Hazard Categorization and Accident Analysis Techniques for Compliance with DOE Order 5480.23, Nuclear Safety Analysis Reports* (DOE 1992d).

The hazard categorization was prepared based on a conservative, credible release fraction (Huang 1995) for FSS as quantified by using the results of the accident analysis (Johnson 1994) and facility-specific threshold quantity (TQ) radionuclide inventories. FSS has been assigned a hazard categorization of Category 3.

Interim Operational Safety Requirements (Besser 1995)

Interim Operational Safety Requirements have been prepared based on this ISB. The current OSRs identified in WHC-CM-5-31, *Operation Safety Requirements Fuel Fabrication Facilities in 300 Area*, associated with former fuel assembly manufacturing will be canceled. The basis for this change is that the current OSRs are no longer applicable for the current and future operational phases.

1.4 SUMMARY OF MANAGEMENT CONFIGURATION SYSTEMS

During shutdown and fuel disposal activities, essential services and buildings will be maintained in a safe and stable environmental condition to protect personnel, the public, and property in accordance with appropriate requirements. Essential systems to be maintained are addressed in the shutdown plan (Dawson 1994).

The following facility specific and site generic configuration management control systems regulate the operation and configuration of FSS:

Interim Operational Safety Requirements (Besser 1995)

The principal FSS administrative controls that are the basis for the safety envelope and associated accident safety analyses and, as such, must be maintained for the validity of the safety envelope are identified in the Interim OSRs (Besser 1995).

Classification of Safety Systems

Accidents with significant dose consequences have been analyzed. Since the maximum releases fall below the Safety Class 1 and 2 lower limits, no Safety Class 1 or 2 structures, systems, or components are required. This Safety Class determination is based on the fire loading of the 3712 Building and the associated worst case fire possible. Refer to Table 1.6.1 for Safety Class categories and associated criteria and calculated radiological consequences and toxicological concentrations for the maximum release.

Westinghouse Hanford Generic Institutional Controls and Safety Programs

The generic institutional controls and safety programs to assure maintenance of FSS in a configuration that supports the defined safety envelope include the following:

- Radiation Protection,
- As Low As Reasonably Achievable (ALARA),
- Occupational Safety,
- Fire Protection,
- Industrial Safety,
- Industrial Hygiene,
- Criticality Safety,
- Training,
- Radioactive Waste Management,
- Occurrence Reporting,

- Quality Assurance,
- Configuration Management,
- Conduct of Operations,
- Emergency Planning, and
- Environmental Protection.

A matrix of the above Institutional Controls or Safety Requirements, DOE Orders and Titles, the Hanford Generic Institutional Controls and Safety Program Controlled Manuals, and FSS-Specific Controls is contained in Table 4.0.1.

Design features that are directed at preventing criticality and reducing dose consequences associated with accidents and that are necessary to be maintained are discussed in Section 3.2.1 of this ISB.

1.5 SUMMARY OF SAFETY ANALYSES

Safety analyses have been performed for FSS to establish a technical justification for the ISB conclusion that FSS does not represent an undue risk to the public, employees, or the environment. The analyses provide a basis for FSS Interim Operational Safety Requirements. This report summarizes and references the several safety analyses that were performed and describes the rationale upon which it was concluded that the current and future FSS cleanup, fuel storage, and fuel handling and packaging activities are within the acceptable risk guidelines.

1.6 CONCLUSIONS

A hazard categorization (Brehm 1995) has been prepared for the facility in accordance with DOE-STD-1027-92 resulting in the assignment of Hazard Category 3 for FSS. Only those buildings that store fuel materials (303A, 303B, 303E, 303G, 3712, and 3716), or are intended to support limited fuel handling or packaging (333), are designated Category 3 buildings. All others are designated radiological buildings.

It is concluded that the risk associated with the current and planned operational mode of FSS (uranium storage, uranium repackaging and shipment, clean up, and transition activities, etc.) are within Risk Acceptance Guidelines per WHC-CM-4-46. The dose and toxicological consequences for a range of credible fires, from a concretion drum fire to a uranium storage building fire, have been analyzed using current Hanford and Westinghouse Hanford accepted methods. The radiological and toxicological consequences for the maximum credible event are less than Guidelines Consequences that would require Engineered Safety Features (Safety Class 1 or 2 items) as shown in Table 1.6-1.

It is also concluded that because of the incredible probability for a nuclear criticality that a Criticality Alarm System (CAS) is not required as allowed by DOE Order 5480.24. The presently installed CAS will continue to be used until current OSRs, WHC-CM-5-31, are canceled.

Table 1.6-1. Safety Class Exposure Limits, WHC-CM-1-3, MRP 5.46. (Safety Class 2 Offsite and Safety Class 3 Limits are Implied).

SAFETY CLASS	RADIOLOGICAL CONSEQUENCES		TOXICOLOGICAL CONCENTRATION	
	Onsite	Offsite	Onsite	Offsite
1		> 500 mrem EDE ^a		> ERPG-2 ^b Be > 25 µg/m ³ U > 0.6 mg/m ³
2	> 5 rem EDE		> ERPG-3 ^c Be > 100 µg/m ³ U > 30 mg/m ³	
3	< 5 rem EDE		≤ ERPG-3 ^c Be ≤ 100 µg/m ³ U ≤ 30 mg/m ³	
Maximum Release (8 hr fire in 3712 Building)	3.9 rem EDE	250 mrem	Be=1.35 µg/m ³ U=3.1 mg/m ³	Be=0.091 µg/m ³ U=0.21 mg/m ³

- a EDE - Effective Dose Equivalent
- b ERPG-2 - Emergency Response Planning Guidelines No. 2
- c ERPG-3 - Emergency Response Planning Guidelines No. 3

2.0 SITE, FACILITY, AND ORGANIZATION DESCRIPTION

2.1 HANFORD SITE AND 300 AREA DESCRIPTION

The DOE Hanford Site lies within the semi-arid Pasco Basin, part of the Columbia Plateau in southeastern Washington State (Figure 2.1-1). The Hanford Site occupies an area of about 1,500 km² (560 mi²) and is about 48 km (30 mi) north to south and 38 km (24 mi) east to west. This land area, with restricted public access, presently provides a buffer for the smaller areas currently used for nuclear materials storage, waste storage, and waste disposal. The Columbia River flows through the northern part of the Hanford Site, and forms part of the eastern boundary as it turns south. The Yakima River runs along part of the southern boundary and joins the Columbia River near the City of Richland. Adjoining lands to the west, north, and east are principally range and agricultural land. The cities of Richland, Kennewick, and Pasco (known as the Tri-Cities) comprise the nearest population center and are located southeast of the Hanford Site.

Figure 2.1-2 shows the facilities on, and the land use of, the Hanford Site. The Hanford Site was initially established in 1943 for production of plutonium by the U.S. Government through the exercise of eminent domain for the Manhattan Project. Current activities on the Hanford Site include lay up of Fast Flux Test Facility (FFTF) reactor, lay up of fuel reprocessing plants, waste management, laboratory operations, ecological studies, and operation of the Washington Public Power Supply System (Supply System) Nuclear Plant No. 2.

Figure 2.1-1. Location of the Hanford Site.

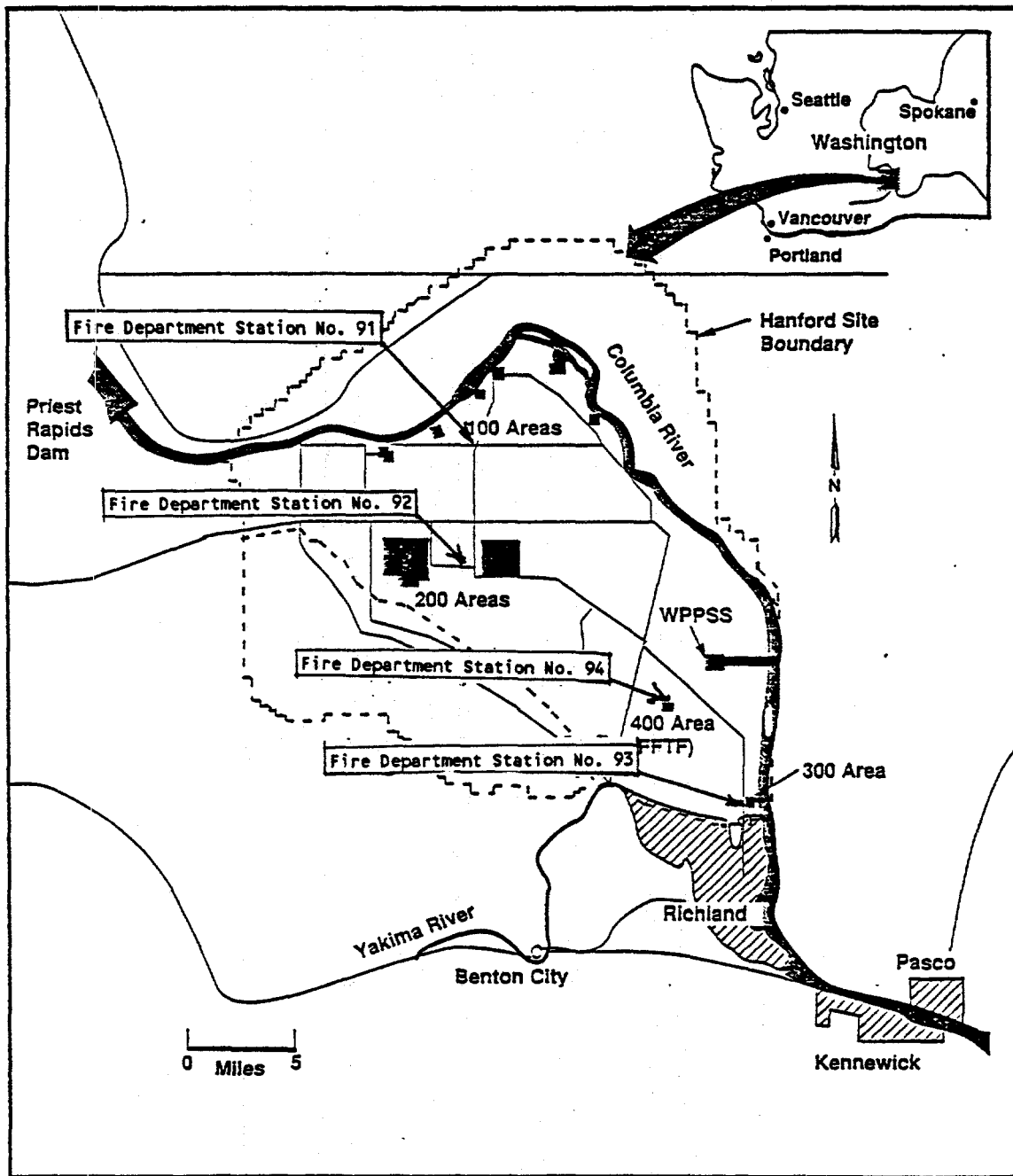

39003074.5

Figure 2.1-2. Features of the Hanford Site.

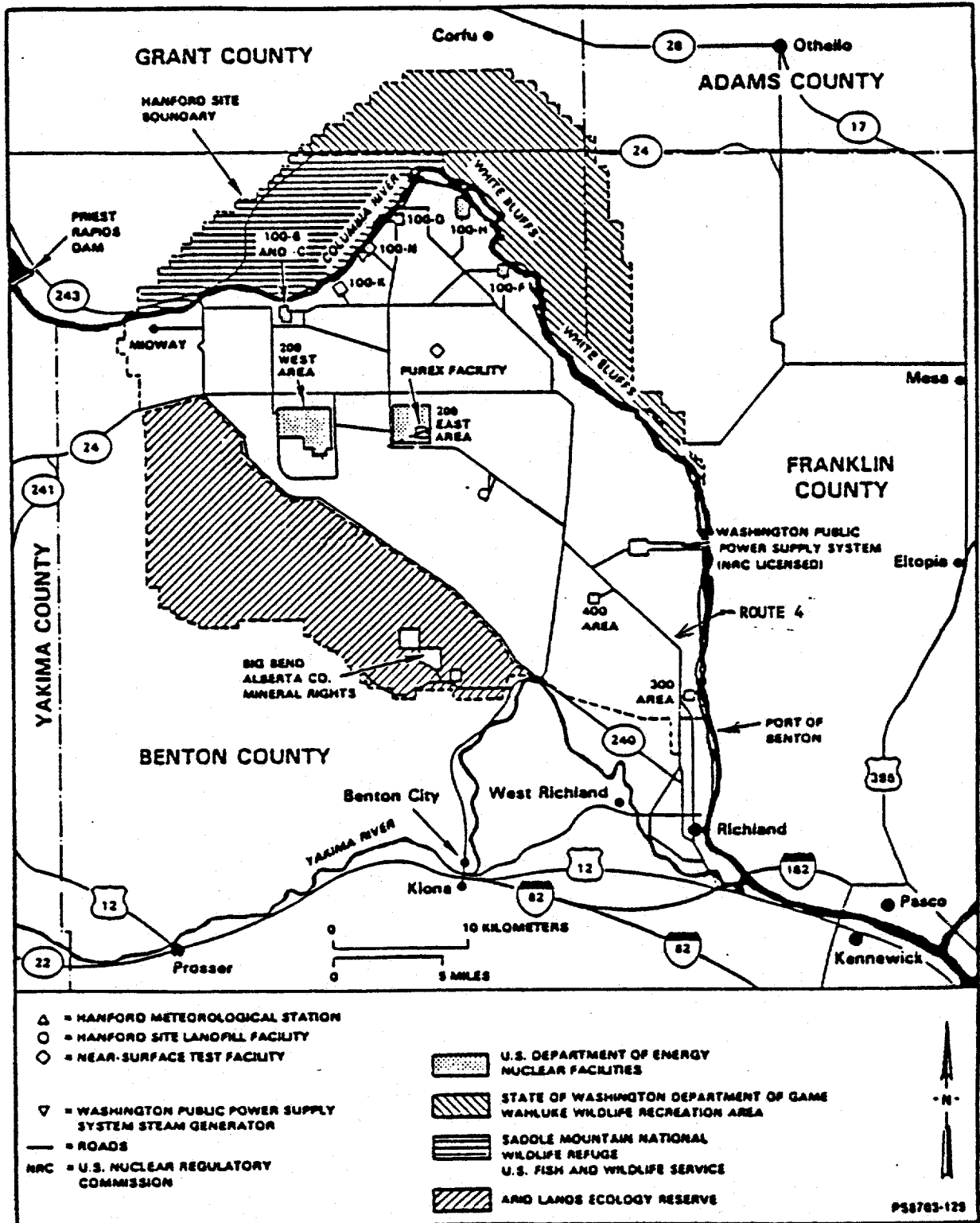
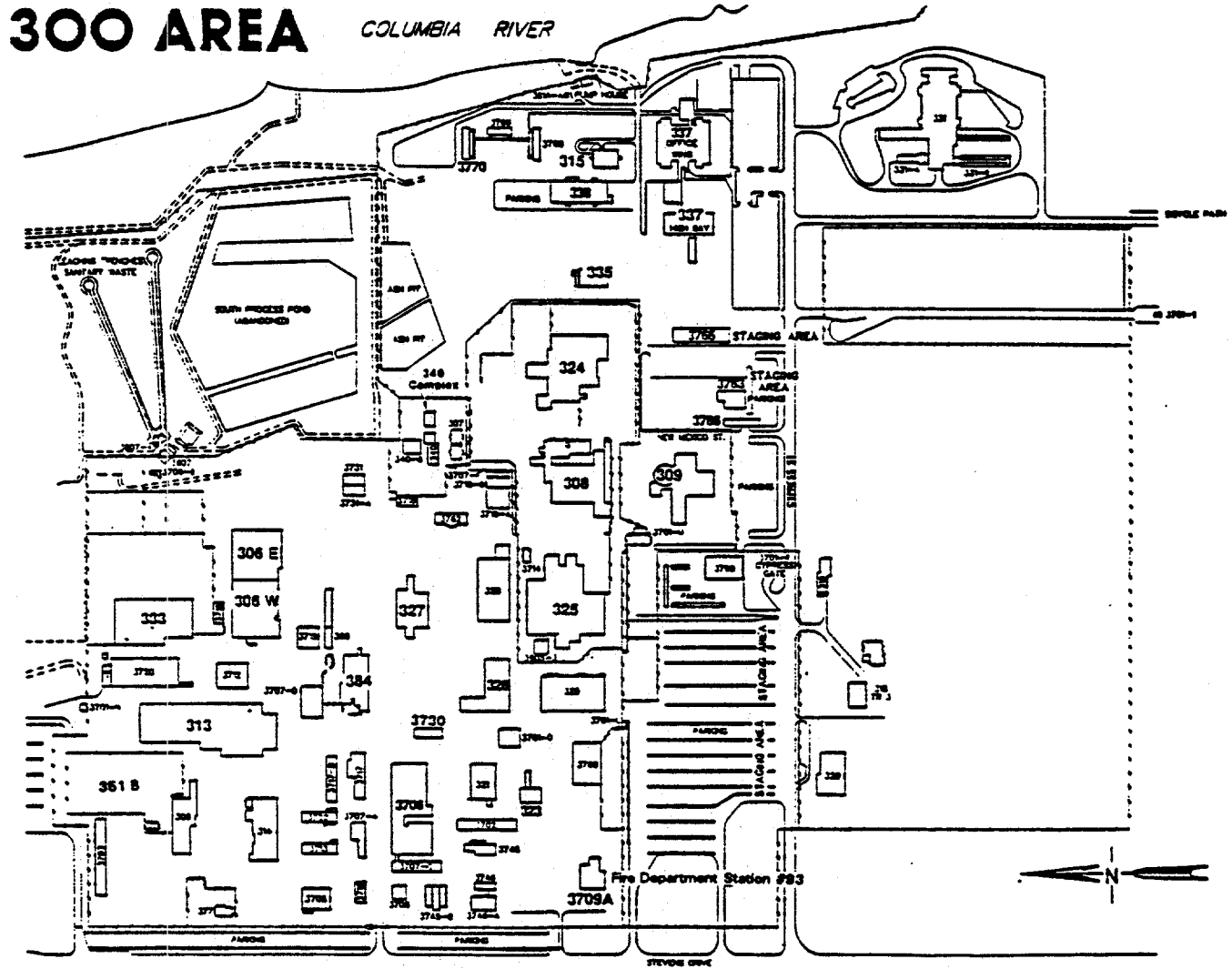

Figure 2.1-3. Hanford 300 Area Detail.



<u>Building</u>	<u>Description</u>	<u>Building</u>	<u>Description</u>
306 East	Fabrication and Testing Lab	327	Post-irradiation Testing Laboratory
306 West	Metal Fabrication Development Bldg	333	N Fuels Manufacturing
308	Fuels Development Laboratory	335	Sodium Testing Facility
309	SP-100 GES	337	High Temperature Sodium Facility
313	Fuels Manufacturing Laboratory	340	Waste Retention & Neutralization
315	Filtered Water Plant	384	Power House
324	Chemical Engineering Laboratory	3709A	Fire Department
325	Radiochemistry Laboratory	351B	Electrical Sub Station

38903039.2

The 300 Area occupies about 1.6 km² (0.6 mi²) of land. See Figure 2.1-3 for the principal 300 Area buildings. The 300 Area is located within the southeast corner of the Hanford Site. It is bounded by the Columbia River on the east and by the Hanford Site Route 4 to the west. The Hanford Site's southern boundary is about 1.7 km (1.1 mi) north of the Richland city limits and about 11 km (6.8 mi) north of the city center. The nearest residence to the 300 Area is about 1.5 km (0.9 mi) to the east, across the Columbia River. A number of irrigated farms are located immediately across the river from the 300 Area. The nearest city water intake is the Richland city pumping station 6 km (3.7 mi) downstream from the 300 Area.

2.2 FUEL SUPPLY SHUTDOWN FACILITY

2.2.1 Background and Facility Description

The facility is managed by the Fuel Supply Shutdown organization reporting to the Fuel Fabrication Facilities Transition Projects (FFFTP). The facility is located in the northeast corner of the 300 area (see Figure 2.2.2-1). The facility includes the following buildings with noncontiguous boundaries: 313, 333, 303-A, 303-B, 303-E, 303-G, 303-K/3707-G, 303-M, 304, 334, 334-A, 3712, 3716, MO-052 (office trailer used by Westinghouse Hanford and contractor personnel), and the Outside Storage and Transfer System including the 311 Tank Farm and the 303-F pump house.

Underlying the area to the east of the 333 Building is an inactive low-level radioactive solid waste burial ground (current Hanford Site waste management identification number 618-1, formerly referred to as 300 Area No. 1 Burial Ground). The burial ground is not addressed by this ISB; the burial ground is a part of the "Comprehensive Environmental Response, Compensation and Liability Act (CERCLA)" (WHC 1989).

The history of the facility began in 1943 when the 313 Building was constructed to house manufacturing equipment for production of fuel for the Hanford single pass reactors. Fuel production began in mid-1944 and continued through the early 1950s. The facility was then expanded to allow for increased fuel production. In the late 1960s, a process, which included nickel plating of the bare uranium cores prior to cladding, was developed and installed. This process continued until 1971, when the six production lines were shut down concurrent with the shutdown of the single pass reactors. Other programs conducted near the 313 Building include support of a tritium production program from 1948 to 1952 and a thorium program in the mid 1960s. For N Reactor fuel fabrication, the 313 Building housed a waste treatment system, administrative offices, and training and warehouse space. This building also housed a complete N Reactor pressure tube fabrication facility consisting of a 4000 ton Sutton extrusion press, draw bench, grinders, autoclaves, inspection equipment, and chemical cleaning equipment. The Hanford Metal Working process equipment has been sold to a commercial company, and the north section of the 313 Building has been leased for three years for the commercial operation of the extrusion equipment.

The 333 Building, constructed in 1958, houses the primary fabrication equipment for manufacturing N Reactor fuel, which began in 1962. From 1965 to 1967, the building was also used to assemble lithium aluminate targets for demonstration of coproduction in the N Reactor. The building contained equipment for all operations from initial component cleaning to finished fuel assembly, inspection, and packaging for shipment. Fabrication activities continued until N Reactor entered the standby phase in 1987, and at that time, the facility also began transition to standby status. Other buildings comprising the facility provide storage space for fuel materials and finished fuel, and contain residual process equipment that supported fuel production. At this time, the Fuel Supply complex is in transition from standby status and undergoing cleanup and shutdown activities required for permanent closure and transfer to decontamination and decommissioning (D&D). The individual buildings are listed in Table 2.2.1-1 with their function/activity and facility classifications.

Table 2.2.1-1. Fuel Supply Shutdown Facility Building Identification, Current Function/Activity, and Hazard Category.

BUILDING	CURRENT FUNCTION/ACTIVITY	HAZARD CATEGORY*
303-A	Fuel Storage	Nuclear Cat 3
303-B	Uranium Billet Storage	Nuclear Cat 3
303-E	Fuel Storage	Nuclear Cat 3
303-F/311-Tank Farm	Pump House/Outside Chemical Storage and Transfer System	Radiological
303-G	Uranium Billet Storage	Nuclear Cat 3
303-K/3707-G	Mixed/Radioactive Solid Waste Storage/ RCRA Closure	Radiological
303-M	Uranium Oxide Facility (Shutdown)	Radiological
304	RCRA Closure	Radiological
313	RCRA Closure	Radiological
333	Cleanup/RCRA Closure	Nuclear Cat 3
334 and Tank Farm	Process Sewer Monitoring	Radiological
334-A	RCRA Closure	Radiological
3712	Finished Fuel & Billet Storage	Nuclear Cat 3
3716	Unfinished Uranium Fuel Storage	Nuclear Cat 3

* Facility Hazard Category (See Section 3.1.1)

2.2.2 Building Description, Construction, and Status

Information on the individual building descriptions and their size, construction, fire protection systems, and status is included below. See Figure 2.2.2-1 and 2.2.2-2 for layout of the buildings with respect to other buildings in the 300 Area. Individual building layouts are shown in figures 2.2.2-3 through 2.2.2-12.

Buildings 303-A, 303-B, 303-E, 303-G Billet/Fuel Storage

Description: The structures are single story, 120.4 m² (1296 ft²), 8.2 m by 14.6 m (27 ft by 48 ft), concrete block and cement construction, three doors, no windows. Roofs are 46 cm (18 in.) precast concrete slabs covered with felt, tar, and gravel. There are four 25 cm (10 in.) diameter holes in the walls at floor level for water drainage. The buildings are unheated. The buildings are equipped with automatic fire detection and sprinkler (dry) systems with freeze protection in the valve rooms.

Status: The buildings are used for fuel and billet storage. 303-A and 303-E contain unirradiated fuel elements (wrapped in plastic) taken from N Reactor which were contaminated with fission and activation products. 303-B and 303-G contain uranium billets. The billets and fuel are stored in wooden boxes. Buildings are kept locked and Tamper Indicating Device (TID) sealed when unoccupied.

Building 303-F Pump House and 311 Outside Chemical Storage and Transfer System

Description: The 303-F Pump House is a 8.2 m x 14.6 m (27 ft x 48 ft) concrete block structure with concrete foundation and floor. The roof is precast concrete slab with tar and gravel surface. The steam formerly used to heat the building has been turned off. There is water (with freeze protection) to the safety shower and eye wash station. There is no fire detection/sprinkler system. The chemical storage and transfer system consists of tanks with catch basins to collect spills, transfer piping in a concrete trench, the 311 tank farm, 303-F pump house, and process sewer lines.

Status: Tank 50 contains liquid waste from contaminated areas. Other tanks are empty. The pump house and storage and transfer system will be used during clean up of acid and caustic waste systems located in 313 Building south.

Building 303-K/3707-G Mixed/Radioactive Solid Waste Storage/Change House and Pad.

Description: 303-K Building is a 8.2 m x 14.6 m (27 ft x 48 ft) building of concrete block and cement construction with concrete foundation and floor, four doors, and no windows. The 3707-G change room is a 4.9 m x 3.7 m (16 ft x 12 ft) metal Butler building with concrete foundation and floor. The roofs are precast concrete covered with felt, tar, and gravel. All drains are blanked off. There is no steam, water, or fire protection for the building.

Status: The 303-K North room is used for waste storage, but is essentially empty and unused. South room is used to store solid nuclear materials (UO₂ and ThO₂) controlled by Westinghouse Hanford Safeguards. Outside fenced concrete pad is used for storage of low level and mixed wastes awaiting disposition. The

RCRA closure plan has been submitted to Washington State Department of Ecology for comment.

Building 303-M Uranium Oxide Facility

Description: The 15.5 m x 10.7 (51 ft x 35 ft) 303-M Building has an attached 4.7 m x 6.1 m (15.5 ft x 20 ft) change room. These precast concrete structures have concrete foundation and floor, and roofs are precast concrete slab covered with felt, tar, and gravel.

Status: The operating area inside the building is radiologically contaminated. Water (including the fire suppression system), steam, electricity, and air have been turned off. The drain in the bermed west side storage-pad has been blanked off to prevent precipitation from entering the process sewer. Building and pad are locked. Closure of this RCRA Part A permitted facility has been deferred to CERCLA. After FSS removes the HEPA filter medium and dust collector medium, the facility will be transferred to D&D for CERCLA cleanup and final disposition.

Building 304 Waste Concretion

Description: The 304 Building is single story, 7.9 m by 14.6 m (26 ft by 48 ft) with a 3.7 m by 4.9 m (12 ft by 16 ft) addition (change room). Construction is steel frame with corrugated steel siding and roof, with concrete foundation and floor. Adjacent is a 6.1 m by 8.2 m (20 ft by 27 ft) fenced concrete pad. There is a fire detection system, but no automatic fire suppression system.

Status: The building and pad have smearable radiological contamination. There is no water to the building, and drains have been blanked off. The building is kept locked. The building is in the final phase of RCRA closure (scheduled for September 1995). After RCRA closure, FSS will complete other work to meet transfer to D&D.

Building 313 Manufacturing Support

Description: The 313 Building is irregular shaped that covers approximately 7,082 M² (76,200 ft²) and includes two types of construction: (1) steel frame with exterior and interior walls of concrete blocks on grade with a precast concrete slab roof with built-up tar and gravel surface, and (2) steel frame with double metal insulated panel exterior wall, light weight metal interior partitions, foundations and floors of concrete or steel decking covering a concrete basement, and a roof of insulated metal covered with tar paper covered with tar and gravel surface.

Only the south end of the building belongs to Fuel Supply Shutdown. The north end is under the control of a private company that is fabricating specialty metal parts. Except for minimal electricity, utilities to the south end of the building have been disconnected, including the fire sprinkler system.

Status: In the south end, the majority of the major fuel fabrication equipment has been removed, and activities are progressing towards RCRA closure followed by building demolition. Anticipated activities required to support closure include: 1) neutralization of cleaning solution, 2) decontamination or stabilization of chemical process tanks and piping, 3) removal of residual hazardous and radiological materials, and 4) final stabilization of remaining constituents prior to building demolition.

Building 333 Manufacturing

Description: The structure, 91.4 m by 42.7 m (300 ft by 140 ft), is steel frame with exterior insulated steel siding. The foundation and ground floor are concrete, and the roof is insulated metal panel covered with felt, tar, and gravel. A mezzanine along the east side accommodates some electrical distribution equipment and a group of fifteen offices. A central mezzanine housed ventilation equipment for the chemical bay and a small mezzanine on the southwest corner accommodates a lunch room. Additional offices are located on mezzanines on the northwest corner and north side of the building. HVAC system for the building consists of a steam heat system and evaporative cooling forced air equipment. The building is equipped with a fire detection wet-pipe sprinkler system. Floor trenches throughout the main building discharge to the process sewer.

Status: A number of areas are radiologically contaminated. Activities are in progress to support RCRA closure and decontamination and stabilization in preparation for turnover for D&D. Some of the offices are in use. There is no storage of nuclear materials except for waste. The facility may potentially be used for repackaging and shipping of the nuclear fuels prior to final disposition.

Building 334-A Waste Acid Storage

Description: The 334-A Building is a 6.1 m x 12.3 m (20 ft x 15 ft) steel frame structure with double insulated steel walls. The foundation and floor are concrete, and the roof is insulated metal panel covered with felt, tar paper, and tar. Within the building is a 3 m (10 ft) deep pit for waste acid tanks and settling tank (empty).

Status: The waste acid collection and storage system is shut down. There is potential for very low-level, radiologically contaminated areas.

Building 334 Process Sewer Monitoring

Description: The 334 Building is a 6.1 m x 4.6 m (20 ft x 15 ft) steel frame structure with double insulated steel walls and concrete foundation and floor. The roof is insulated metal panel covered with felt, tar paper, and tar. The building is heated by an

electric heater. There is no automatic fire alarm/protection system. The building contains pH monitors with chart recorders for monitoring liquid effluent discharges from the 313, 333, and 3720 Buildings [the 3720 Building is managed by Battelle Pacific Northwest Laboratories (PNL)]. It is also used for minor storage.

Status: Active process sewer environmental monitor operation.

Building 3712 Finished Fuel and Billet Storage

Description: The 3712 Building is a one story steel frame structure, 27.4 m x 32.9 m (90 ft by 108 ft), with metal panel siding and roof, with a concrete floor and foundation. It is equipped with an automatic fire alarm and sprinkler (dry) system with freeze protection in the valve room. The steam heated forced air system is inactive. There are no floor drains. The building floor is at or above grade, and the structure is supported approximately 8 in. above the floor on a concrete curb. Water accumulation would naturally be retained by this curb; however, there are two 5 m (16 ft) wide roll-up doors, with 11 cm (4.5 in.) high flaps at the bottom for drainage and two 2 m (8 ft) and two 1 m (3 ft) doors.

Status: The building is used for storage of uranium billets and finished fuel in wooden boxes, uranium scrap and standards, and unfinished fuel pieces. Zirconium-beryllium braze rings, previously stored in the building, have since been transferred for excess and are no longer stored at the FSS. The building is kept locked and TID sealed when unoccupied.

Building 3716 Unfinished Uranium Fuel Storage

Description: The 3716 Building is a single story, 12.2 m by 24.4 m (40 ft x 80 ft) aluminum frame building with corrugated aluminum siding and roof. The building is equipped with an automatic alarm and a sprinkler (dry) system with freeze protection in the valve room. It has a floor trench to the 6-inch diameter process sewer and a flap at the bottom of the south roll-up door for potential water drainage.

Status: The building is used for storage of unfinished fuel pieces capped with plastic caps in wooden boxes. Building is kept locked and TID sealed when unoccupied.

Figure 2.2.2-3. Buildings 303-A, 303-B, 303-E, and 303-G:
Uranium Billet and Fuel Storage

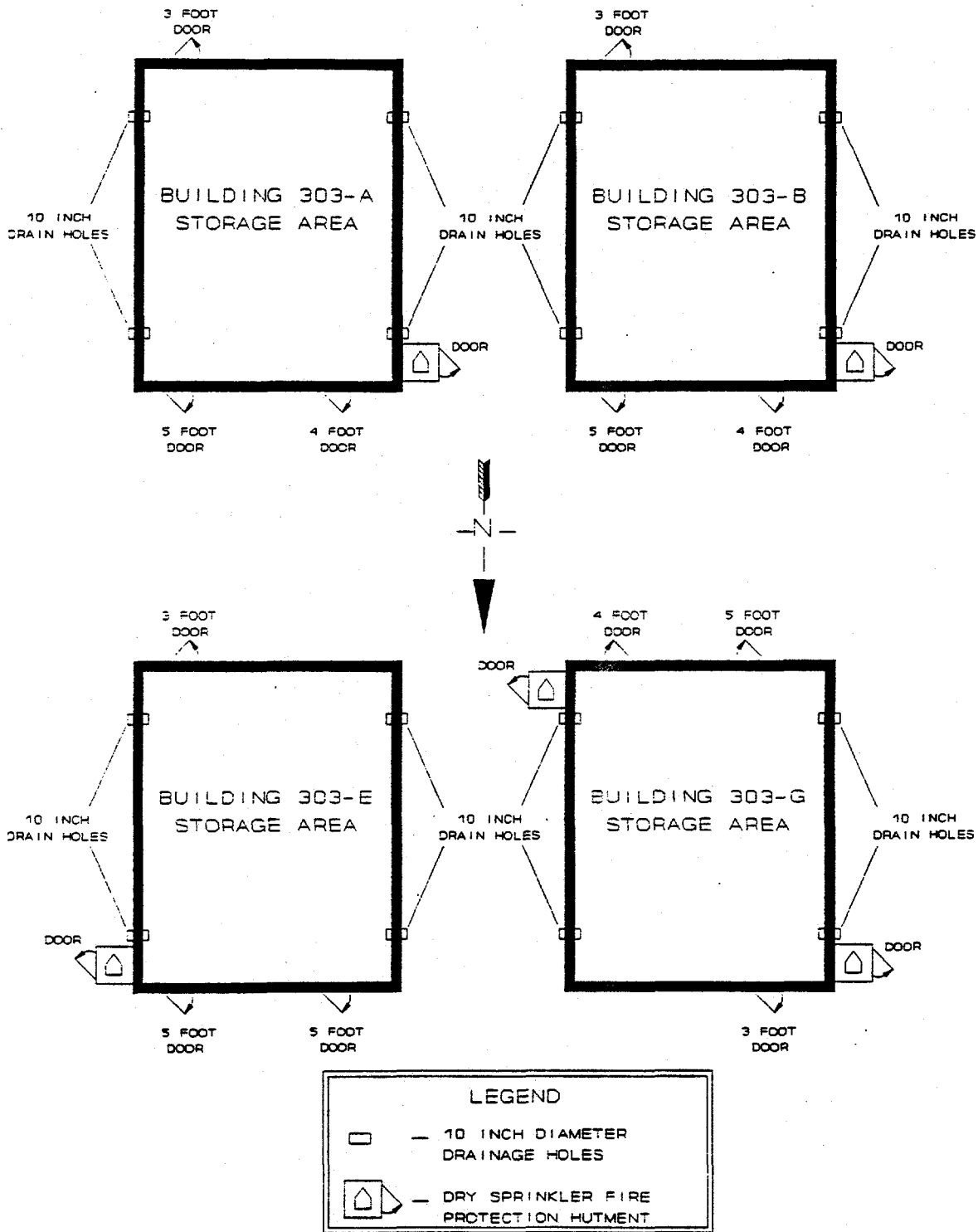

Figure 2.2.2-4. Building 303-F Pump House and 311 Tank Farm.

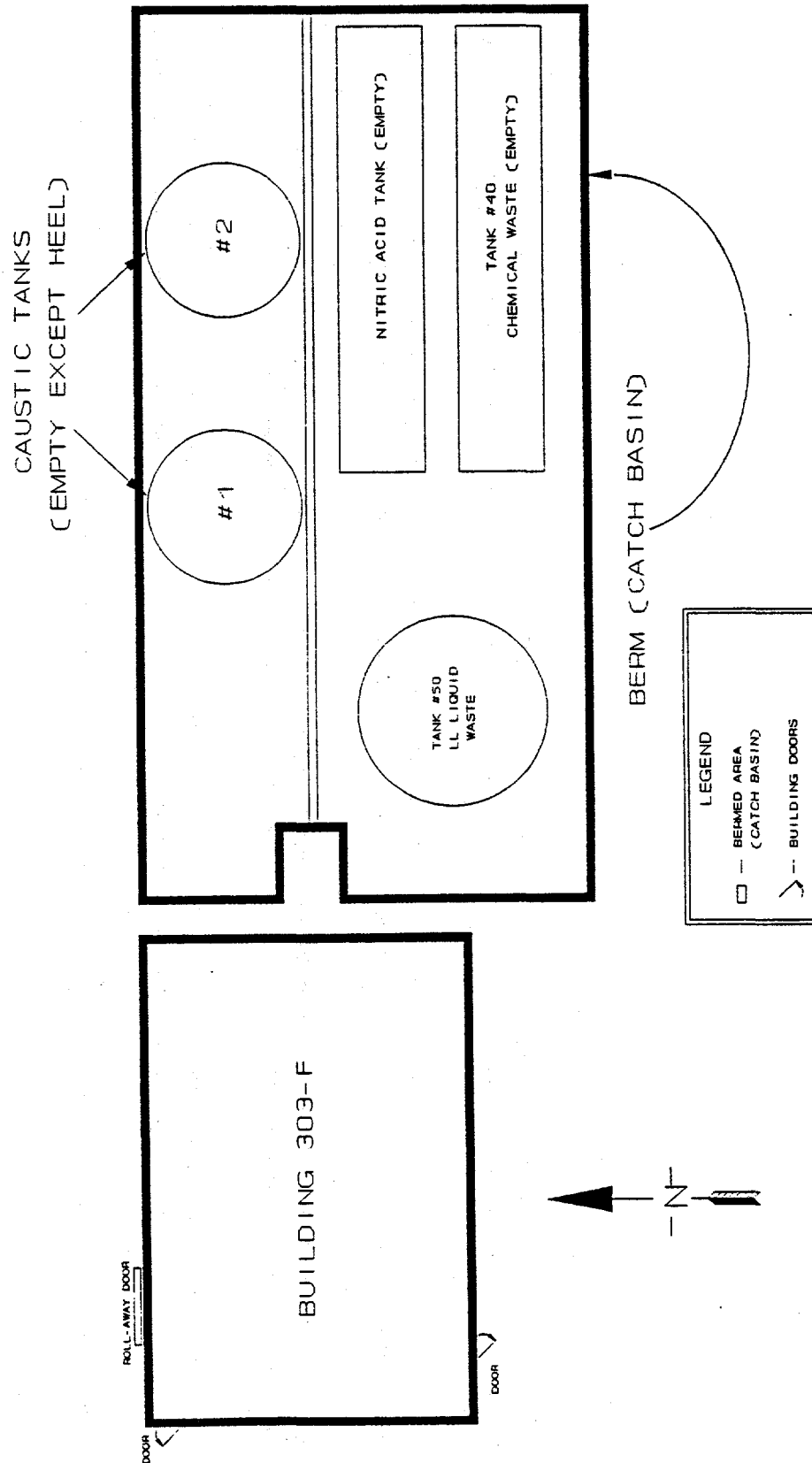

Figure 2.2.2-5. Building 303-K/3707-G: Mixed/Radioactive Solid Waste Storage/RCRA Closure

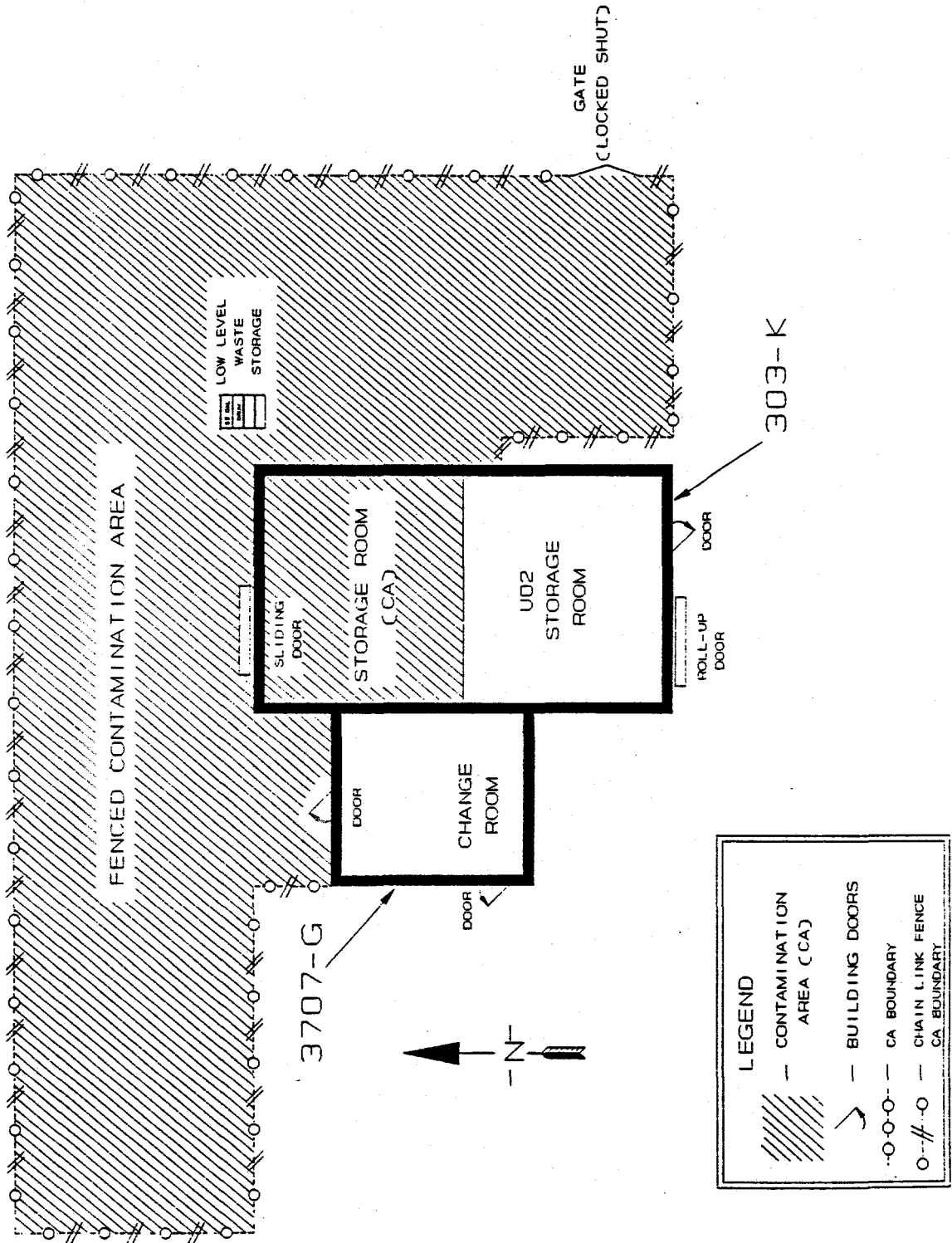

Figure 2.2.2-6. Building 303-M: Uranium Oxide Facility

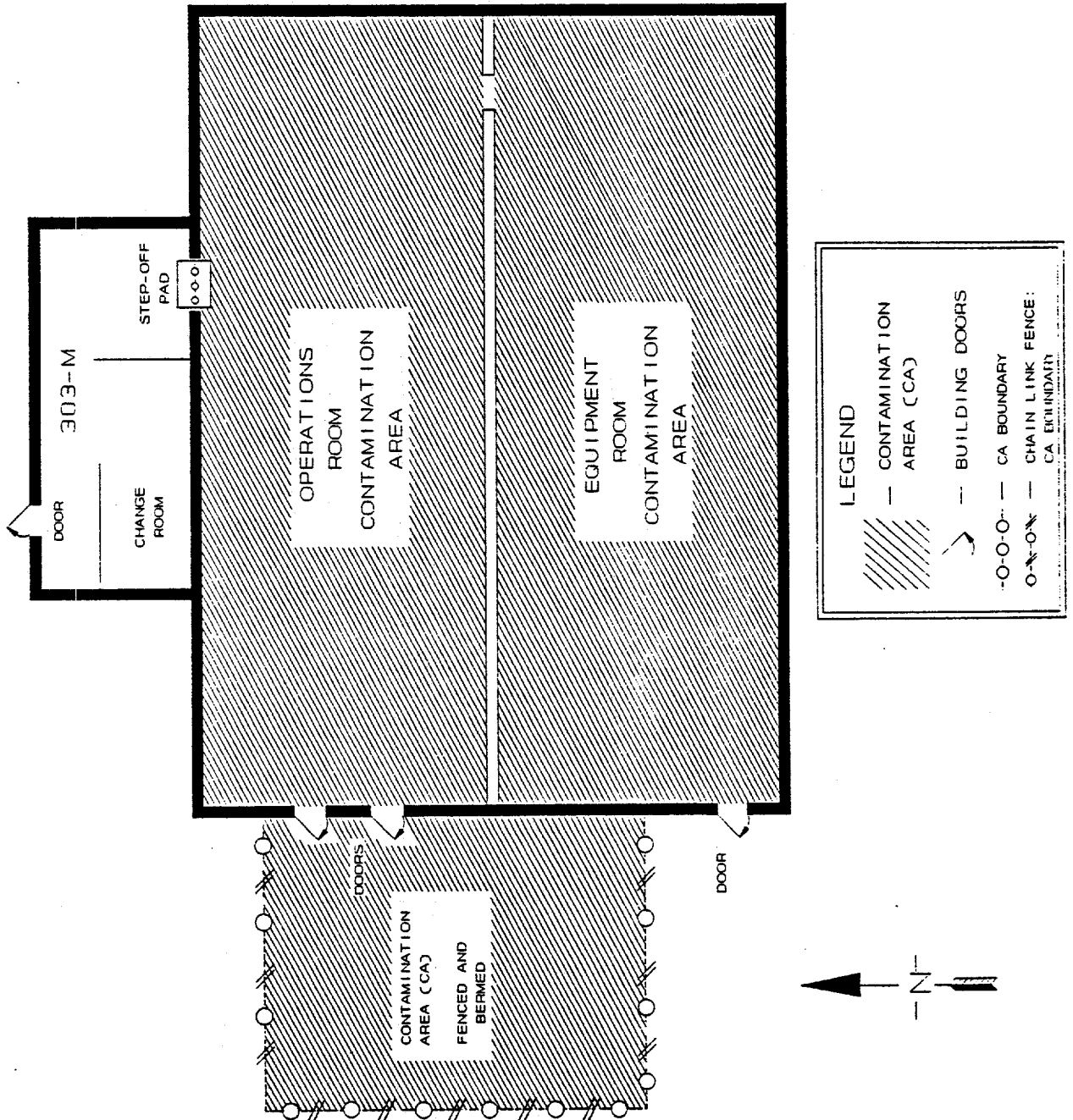

Figure 2.2.2-7. Building 304: Waste Concretion.

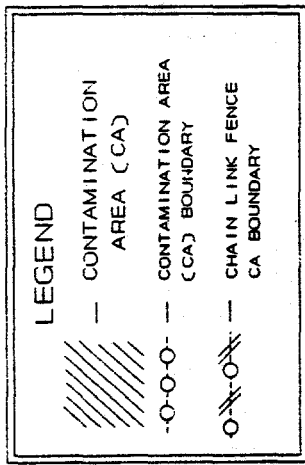
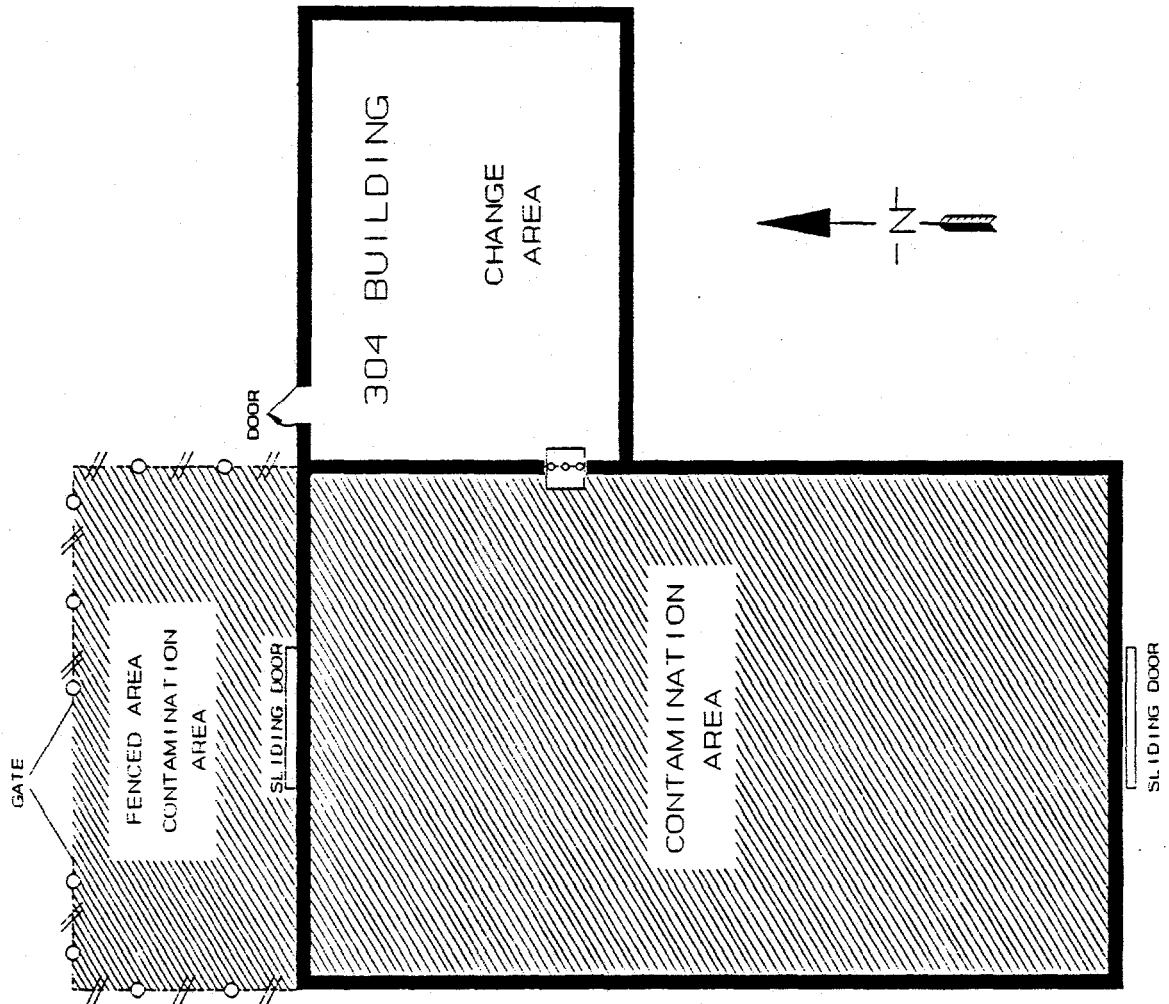

Figure 2.2.2-8. Building 313: Manufacturing Support facility.

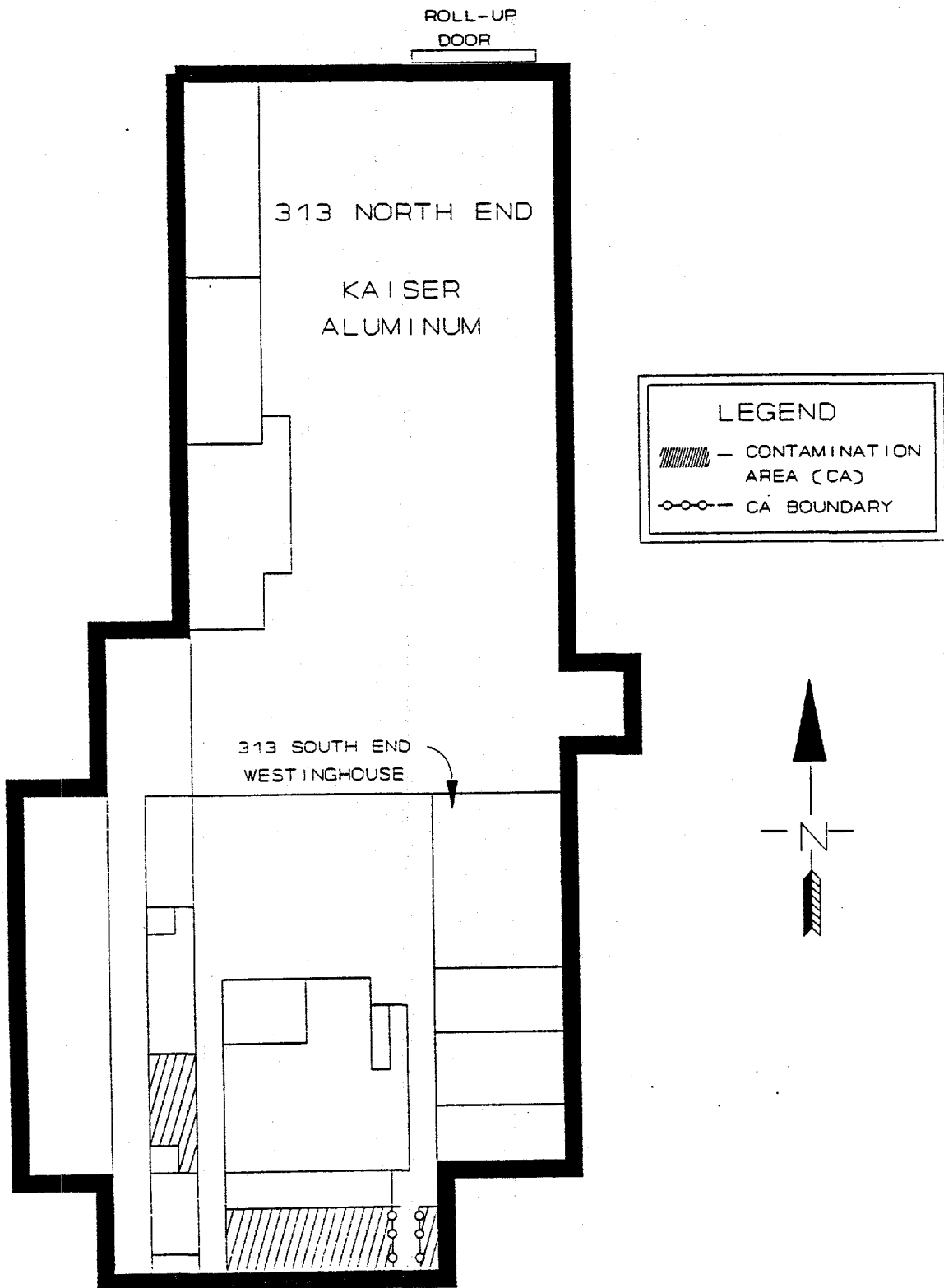

Figure 2.2.2-9. Building 333: Manufacturing Facility.

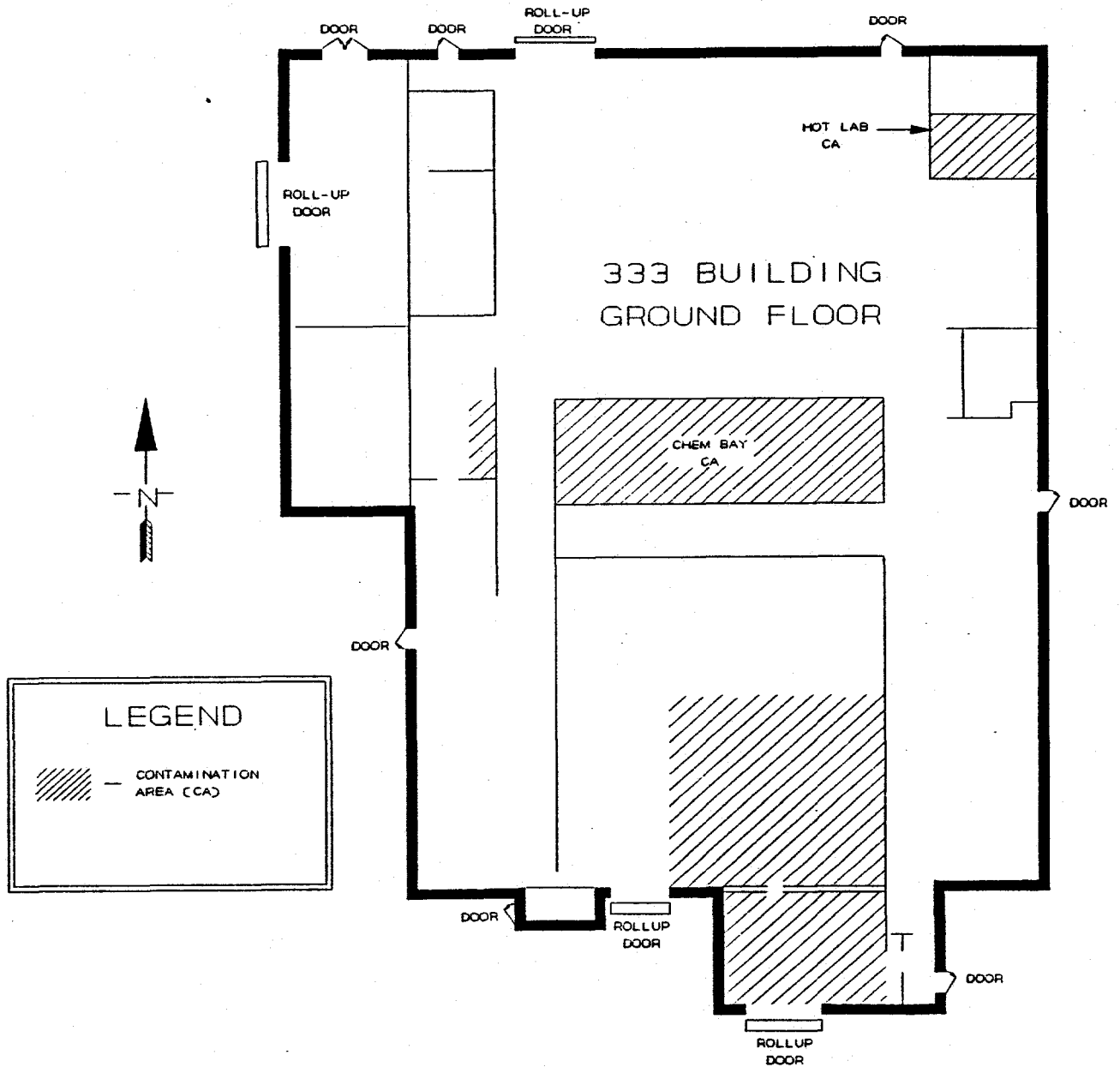

Figure 2.2.2-10. Building 333: Mezzanines.

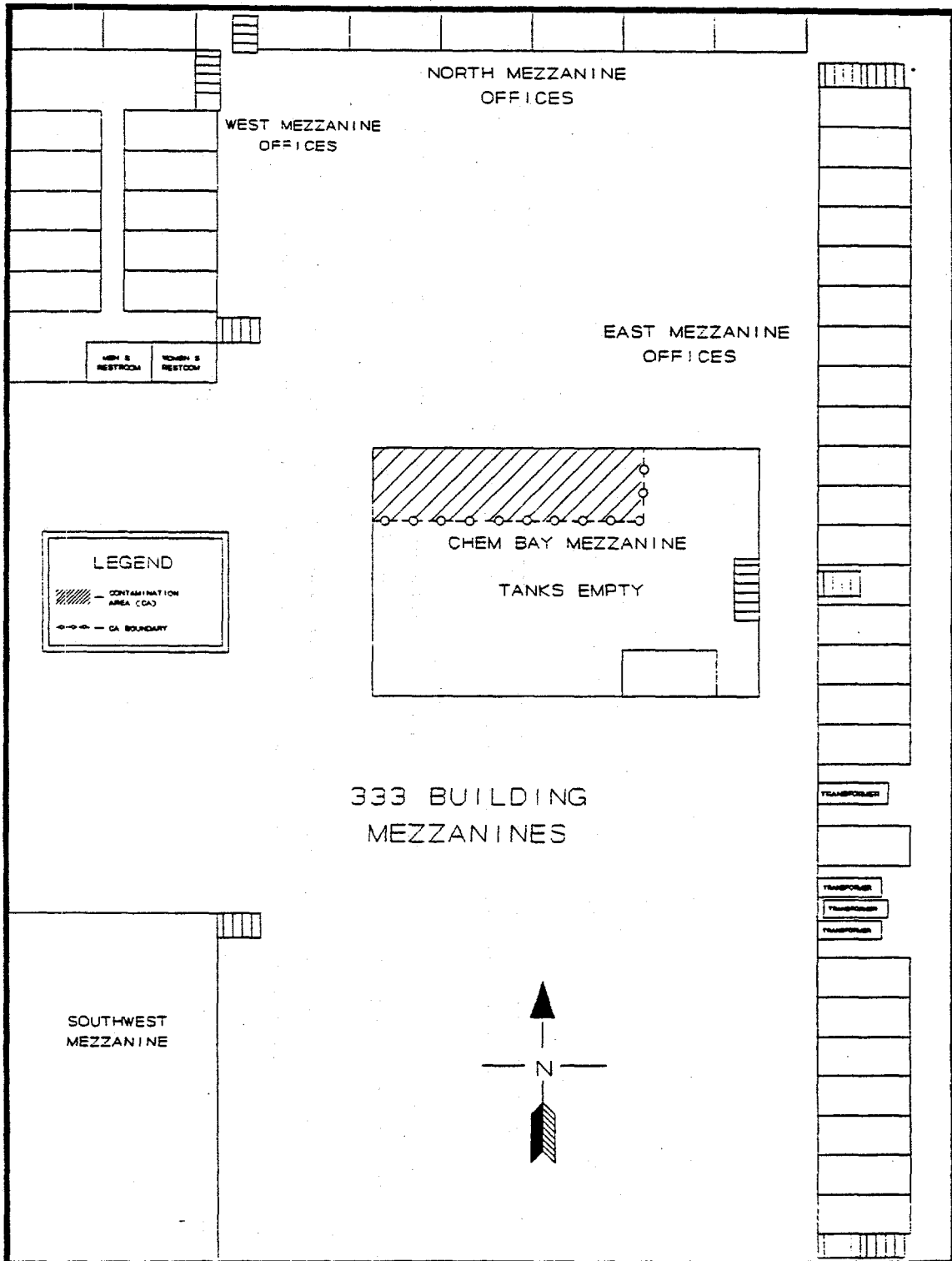

Figure 2.2.2-11. Building 3712: Uranium Finished Fuel and Billet Storage.

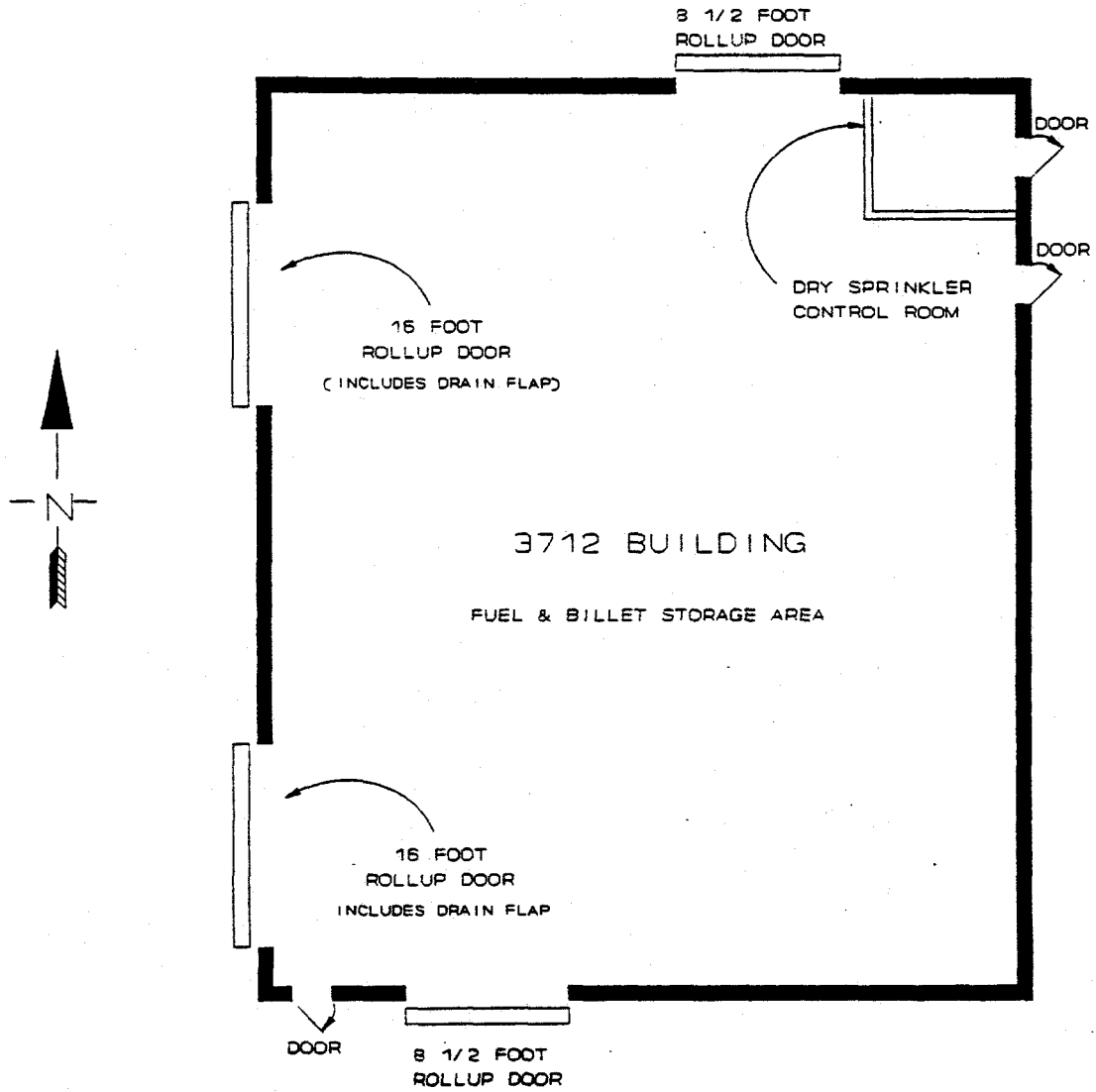
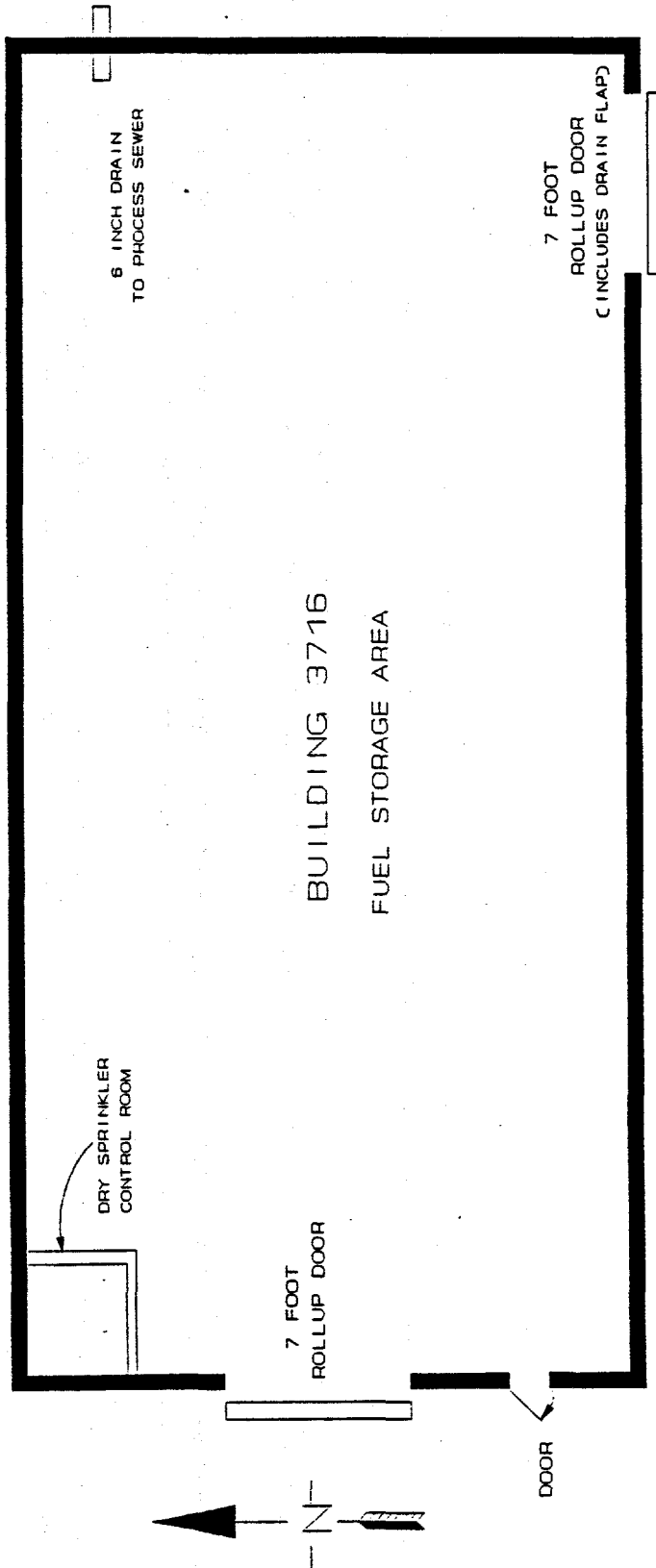

Figure 2.2.2-12. Building 3716: Unfinished Uranium Fuel Storage.



2.2.3 Current and Planned Operational Mode

The transition from standby to the shutdown phase began in March 1992. Three major areas of work are planned for completion by fiscal year (FY) 2002, provided necessary funding is achieved: consolidation of the uranium fuel, completion of work defined in the RCRA Closure Plans, and shutdown and cleanup of the remaining facility for turnover to the D&D organization. The FSS operating staff currently manages these activities and provides surveillance and basic maintenance for the facility. The operations staff is also involved with the disposal of essential materials and waste.

A significant unirradiated uranium inventory, present at the time N Reactor standby was announced, is stored in the facility. A major portion of the 1903 metric tons uranium inventory consists of 0.95 wt% to a maximum of 1.25 wt% ²³⁵U enrichments now packaged in wooden boxes and stored in six buildings. The majority of the uranium is in the form of extrusion billets. Part of the uranium inventory is in the form of fuel elements, some of which were partially fabricated at the time operations ceased. A portion of the fuel had been loaded into N Reactor, but was never irradiated and later returned for storage at the facility. This fuel has low-level fission and activation radionuclide surface contamination. The uranium will require storage at the facility until an alternate storage facility or specific use/user has been identified. The storage buildings will require continuing surveillance, including building and system maintenance, active fire systems, safeguards and security, and regulatory compliance until the uranium has been relocated for alternate storage or use.

Several RCRA Closure Plans have been prepared for several of the non-uranium storage buildings, (DOE-RL 1989, DOE-RL 1990a, DOE-RL 1990b, and DOE-RL 1991). The RCRA closures for these buildings are expected by October 1, 1998 (provided that required funding is available), prior to turnover to the D&D organization. Besides the RCRA closure, the non-uranium storage buildings will require removal of radioactive and hazardous wastes, cleanup and/or stabilization of radioactive/contaminated areas and process equipment, removal of excess materials, and disposition of assets prior to acceptance into the D&D program scheduled for FY 2002 (depending on funding availability).

Removal of bulk chemical inventories was completed in April 1991. The cleanup of uranium residues from fabrication equipment was completed in FY 1994. Cleanup has minimized radiological concerns and eliminated the risk of spontaneous or accidental fires involving residual pyrophoric uranium chips and fines.

The remaining chemicals stored in the facility (February 1994) to support follow on cleanup and shutdown activities are as follows:

Sulfamic acid	313 Bldg South Room	<22.5 kg (50 lbs)
Sodium carbonate	303-F Bldg North Room	<103.5 kg(230 lbs)
Sulfuric Acid, 93 %	333 Storage Shed, north of the 333 Bldg	<110 gal

Neutralized Waste,
pH 11.1, Tank 50

311 Tank Farm

4,200 gal

This ISB will cover the facility throughout the cleanup and shutdown activities, fuel storage operations, and limited fuel handling and packaging for shipment until turnover to the D&D organization. Limited fuel handling and packaging is defined as fuel handling in only quantities less than the minimum hemispherical safe mass quantities (Schwinkendorf 1995). The current CAS will remain operational until the current operational safety requirements (OSRs) are canceled by DOE-RL.

2.2.4 Major Nuclear Facility Processes and Facility Segments

With cleanup and shutdown activities underway, "major processes" no longer applies to existing conditions. Using a graded approach, only systems that provide or support the uranium storage function, which represents the major nuclear safety concerns, are identified and addressed in this ISB. Buildings in which uranium fuel is being stored require periodic surveillance for fire systems, maintenance, safeguards, and regulatory and DOE compliance.

It is anticipated that handling and packaging of uranium fuel for disposal and temporary storage of the packaged material, as in the case of recent billet shipments to the United Kingdom, will also take place in the 333 Building.

2.2.5 Facility Support Systems

2.2.5.1 Heating, Ventilation, and Air Conditioning (HVAC). Conditioning of the 333 Building air is accomplished with conventional steam heat and forced-air evaporative cooling equipment. This ventilation system is not HEPA filtered. The exhaust and HEPA filter systems associated with specific fuel manufacturing processes and equipment that had the potential for generating airborne contamination were shut down and blanked off when processing ceased. No other buildings except trailer MO-52 have an active heating or cooling system.

2.2.5.2 Electrical Power. Offsite power is supplied from the Bonneville Power Administration (BPA) network to the 115-kV/13.8 B3-S4 substation in the 300 Area. The 300 Area 13.8-kV distribution lines supply a variety of office, laboratory, and fabrication facilities in the 300 Area.

Two separate lines run through the 300 Area distribution system to the C-3-3 switching station and then to the facility 13.8-kV/480-V substation. The power is used for residual required functions, i.e., HVAC, lighting, offices, heating of the fire protection valve enclosures, fire protection alarm systems, etc.

There is no requirement for emergency power to the facility; however, some general lighting in the 313 and 333 Buildings is on emergency power.

2.2.5.3 Water Systems. Water for the facility is supplied from the 300 Area water supply system. This distribution network supplies both the sanitary and

fire protection water for the entire 300 Area. It consists of multiple supply pumps, a filter plant, a chlorine addition system, and distribution network. Two head tanks are provided on the network to pressurize the 300 Area system in case the normal supply pumps fail or the back-up engine-driven pumps fail to start. The water supply system is separated into fire protection, sanitary water, and process water systems.

With the fuel fabrication operations shut down, the primary water usage is sanitary and fire protection.

2.2.5.4 Drains, Trenches, and Process Sewer System. Sanitary drains flow to the 300 Area sanitary drain trenches. Floor and trench drains flow to the 300 Area process sewer system trench at the northeast of the 333 Building. The pH of the effluent to this process sewer is monitored by the 334 Building process sewer monitoring instrumentation.

When the Facility Effluent Monitoring Plan (FEMP) (Nickels and Brendel 1991) for the facility was published, the facility fuel fabrication activities were no longer being performed. Routine liquid effluent discharge to the 300 Area process Sewer has been decreasing ever since and is now limited to that required to maintain the pH monitor. However, there is potential for liquids to enter the process sewer from steam condensate, cleaning, and storm water. The facility was reevaluated using the FEMP determination process, and it was determined that no facility-specific FEMP is required (Frazier 1994).

2.2.6 Radioactive and Hazardous Wastes

2.2.6.1 Liquid Wastes. The principal facility liquid waste discharges to the 300 Area Process Sewer are HVAC and sump condensate, controlled and non-controlled precipitation, and fire protection system releases. A complete description of the discharges to the process sewer system is contained in the FEMP (Nickels and Brendel 1991). There are no anticipated radioactive liquid waste discharges.

There are no releases or interconnections to the Westinghouse Hanford 340 Radioactive Liquid Waste System.

The FEMP has been reviewed, since the facility mission has changed from operations to shutdown and no longer releases effluents to the environment. The facility was reevaluated using the FEMP determination process, and it was determined that no FEMP is required (Frazier 1994).

2.2.6.2 Radioactive Gaseous Wastes. The exhaust and HEPA filter systems associated with specific fuel manufacturing processes and equipment that had the potential for generating airborne contamination were shut down and blanked off. With this shut down, there are no anticipated radioactive gaseous waste discharges.

The 304 Concretion Facility that had the potential for generating radioactive airborne emissions completed operations in FY 1994.

2.2.6.3 Radiological Hazardous Waste. Wastes generated from activities associated with the transition from standby to shutdown consist primarily of

cleaning materials and those associated with cleanup of the radiological surface-contaminated and RCRA areas. The hazardous wastes include residual Be and asbestos. The waste management details are described in the *Low Level, Mixed, Hazardous and Nonregulated Waste Certification Plan for Facility Operations/N Reactor Plant/Fuel Supply Facilities* (Weakley 1993). The certification process waste generation criteria include:

- Controls to reduce waste generation
- Establishment of waste minimization programs
- Segregation of low level, mixed, hazardous, and nonregulated waste
- Low level, mixed, hazardous, and nonregulated waste management
- Incorporation of design principles to minimize waste generation
- Waste treatment
- Audits
- Annual update of 30-yr forecast.

Normal radiological dose rates and contamination levels associated with the facility are included in Table 2.2.6-1. These dose rates are from residual fixed and removable residual uranium and uranium compounds resulting from the fuel manufacturing process. Some trenches and drains also contain small residual uranium and various uranium compound contamination.

The facility total dose impact associated with the four facility radiation workers and their two supervisors was less than 0.15 rem for calendar year 1993. Exposures are documented in Facility Radiological Exposure Status Reports. Future facility dose impact is expected to be less because of the change in facility operation mode to primarily fuel storage and associated surveillance. Exposure impact associated with the HPTs that provide radiological services to the facility is not included because they are assigned to a multitude of facilities; the dose impact would be expected to be less than that of the facility radiation workers. The dose impact to other facility and onsite workers is considered inconsequential with respect to natural background levels.

Table 2.2.6-1. Facility Radiological Dose Rates and Contamination Levels.

LOCATION	MAXIMUM DOSE RATE	GENERAL AREA DOSE RATE	FIXED CONTAMINATION LEVELS (MAXIMUM)	REMOVABLE CONTAMINATION LEVELS (MAXIMUM)
303-A*, B, E*, G Fuel Storage	7 mrem/hr	4.5 mrem/hr	<1,000 dpm beta-gamma <20 dpm alpha	Not applicable
303-F/311 Tank Farm	<0.5 mrem/hr	<0.5 mrem/hr	<1,000 dpm beta-gamma <20 dpm alpha	<1,000 dpm beta-gamma <20 dpm alpha
303-K Building and Yard	3 mrem/hr	<0.5 mrem/hr	250,000 dpm beta-gamma 8,500 dpm alpha	2,000 dpm beta-gamma <20 dpm alpha
303-M Building	<0.5 mrem/hr	<0.5 mrem/hr	100,000 dpm beta-gamma 1,400 dpm alpha	100,000 dpm beta-gamma 1,400 dpm alpha
304 Building	2 mrem/hr	<1 mrem/hr	100,000 dpm beta-gamma 1,050 dpm alpha	10,000 dpm beta-gamma 350 dpm alpha
313 Engineering Hot Lab	14 mrem/hr	1 mrem/hr	14 mrad beta-gamma 20,000 dpm alpha	45,000 dpm beta-gamma 3,000 dpm alpha
313 Bermed Area	<0.5 mrem/hr	<0.5 mrem/hr	60,000 dpm beta-gamma 1,400 dpm alpha	2,000 dpm beta-gamma <20 dpm alpha
333 Engineering Hot Lab	0.8 mrem/hr	<0.5 mrem/hr	700,000 dpm beta-gamma 20,000 dpm alpha	100,000 dpm beta-gamma 7,000 dpm alpha
333 South End Saw Area	35 mrem/hr	<0.5 mrem/hr	3 mrad beta-gamma 200,000 dpm alpha	70,000 dpm beta-gamma 11,000 dpm alpha
333 Chem Bay and Mezzanine	1.5 mrem/hr	<0.5 mrem/hr	20,000 dpm beta-gamma 150,000 dpm alpha	15,000 dpm beta-gamma 700 dpm alpha
333 Uranium Billet Cleaning Areas	<0.5 mrem/hr	<0.5 mrem/hr	60,000 dpm beta-gamma 1,400 dpm alpha	1,400 dpm beta-gamma 3,000 dpm alpha
334 Process Sewer Monitoring	Not Applicable	Not Applicable	<1,000 dpm beta-gamma <20 dpm alpha	<1,000 dpm beta-gamma <20 dpm alpha
3712 Billet Storage	5 mrem/hr	1.5 mrem/hr	<1,000 dpm beta-gamma <20 dpm alpha	Not applicable
3716 Billet Storage	9 mrem/hr	3 mrem/hr	<1,000 dpm beta-gamma <20 dpm alpha	Not applicable

* Unirradiated fuel assemblies potentially surface contaminated with activation and fission products.

2.2.7 Fuel Supply Shutdown Facility Organization

The Fuel Supply Shutdown organization is described in WHC-CM-5-35, Fuel Supply Operations Control Manual.

The organization is comprised of management and clerical personnel, cognizant engineers, hazardous waste specialist, and metal operators who are responsible and perform duties required for management, operation, surveillance, maintenance, RCRA, and facility cleanup and shutdown.

2.2.8 Principal Interfaces and Support

Organizations interfacing with and providing support to Fuel Supply include:

- OPS, Central Support Services (maintenance support)
- ESQ, South Area and Support Services Health Physics
- Safety Analysis and Nuclear Engineering, Safety Analysis and Evaluation
- ESQ, Quality Assurance
- ESQ, Safety
- RR, Regulatory Support (environmental assurance).

2.2.9 Facility Access Control

The facility is within the fenced 300 Area where pedestrian gates are unlocked.

The 333 Building is locked except during occupied shifts. Key card control access is utilized during off shifts. Key cards are issued to occupants, service personnel, Hanford Patrol, Fire Department, and other support personnel. All other buildings remain locked unless opened for specific surveillances, maintenance, or cleanup activities.

Tamper-indicating devices (seals) are also used on doors into SNM storage areas: 303-A, 303-B, 303-E, 303-G, 3712, and 3716.

2.3 FACILITY FIRE PROTECTION

2.3.1 Facility Fire Protection

Each of the unheated uranium storage buildings is equipped with an automatic fire alarm and dry sprinkler system with freeze protection in the deluge valve rooms. The sprinkler and alarm systems were installed in the mid 1980s to contemporary standards at the time and are maintained to National Fire Protection Association codes and standards. Sprinkler/alarm systems are also installed in the 333 Building, and fire alarm boxes are located inside and outside the building's rooms, and any operation of these systems annunciates to the Hanford Fire Department Stations. In addition, telephones

are located at locations inside non-fuel storage buildings and are available for contacting the Fire Department via the site 911 emergency notification protocol.

The facility fire protection alarm system is part of the Hanford Fire Department Station No. 2 radio fire alarm reporting system. All the detectors at the facility are in series and tied into the system. Actuation of a trouble alarm will sound in the Hanford Fire Department Station No. 2 Central Dispatch office, alerting people in this continuously manned area of this condition. The Station No. 93 on-shift crew will then be dispatched to investigate and notify Fire System Maintenance and take action to mitigate the concern.

The normal water supply to the facility fire protection systems, both the sprinklers and outside hydrants, is the 300 Area sanitary water system.

Additional information on the sprinkler and alarm system, capacities and response to fires, and associated maintenance and surveillance are contained in the fire hazard analyses (Myott 1994, 1995).

2.3.2 Hanford Fire Department

The Hanford Fire Department consists of four stations:

- Hanford Fire Department Station No. 91 is located central to the 100 Area reactors and is about 53 km (33 mi) away,
- Hanford Fire Department Station No. 92, the 609-A Building, is located central to the 200 Area chemical processing facilities, and is about 35 km (22 mi) away,
- Hanford Fire Department Station No. 93, the 3709-A Building, is located at the southeast corner of the 300 Area and is about 0.4 km (0.25 mi) away, and
- Hanford Fire Department Station No. 94, 4709-A Building, is located at the 400 Area, about 9.6 km (6 miles) away.

The Fire Department Stations and engines are equipped with separate radio systems for communication during emergencies.

Fire fighting personnel periodically inspect and test the fire protection systems and equipment in accordance with WHC-CM-4-41, *Fire Protection Manual*, Section 4.0, "Fire Protection Systems," which addresses inspection, testing, and maintenance.

Further information on the Hanford Fire Department, protection systems, and associated operation, maintenance and surveillance, training requirements, and response times is contained in the fire hazard analyses (Myott 1994, 1995).

2.4 NEARBY FACILITIES AND ACTIVITIES

Following is information on near-by facilities operated by other Westinghouse Hanford organizations and PNL that were considered to have the potential for impacting the facility:

3720 Central Services Laboratory

The 3720 Central Services Laboratory was built in 1959 on the site of the old 3722-A Building, and was used by General Electric, Douglas United Nuclear, and United Nuclear Industries for analytical chemistry work in support of Hanford Works reactors in the 1960s and early 1970s. It is a two-story metal frame structure, 73.2 m by 30.5 m (240 ft by 100 ft), erected on a concrete foundation, footings, and floor slab, with a basement 7.3 m by 33.2 m (24 ft by 109 ft) under the southwest corner. In 1980, a one-story concrete block addition, 14.6 m by 12.2 m (48 ft by 40 ft), was constructed on the north end, giving the structure a total area of nearly 2,323 m² (25,000 ft²). The addition contained general laboratory and office facilities.

The building, now called the Central Services Laboratory, is used by PNL for vitrification and grout developmental experiments, including radioactive laboratory work. The radioactive and other hazardous material content is relatively small, and the facility is classified a fissile exempt facility. The process sewer effluent from the 3720 building is combined with that from the process sewer from the 333 Building before being pH monitored in the 334 Building.

To the south of the 3720 Building is an underground propane tank which has not been used for several years and is not scheduled to be placed back in service.

306 Metal Fabrication Development Building

The initial mission for the 306 Building, also known as the "Met Semi-Works", was to support 313 building operations and to pilot process improvements in single-pass reactor fuel fabrication methods. Later it was expanded to contain the co-extrusion fabrication process for N Reactor fuel elements.

The overall building dimensions are approximately 55 m by 115.8 m x 7.6 m high (180 ft by 380 ft by 25 ft high), with a total area of 7,447 m² (80,160 ft²). The building is two stories high, with no basement, and has a framework of bolted steel.

Throughout the history of the 306 Building, its missions have centered on various alloy and fabrication test and development work. The 306 Building continues to operate today, performing a variety of fabrication tasks under joint Westinghouse Hanford-PNL occupancy.

The 306W (PNL) Building is a fissionable material facility and contains two minimum critical masses of low enriched uranium. Plans are underway to excess this material.

The 306E (Westinghouse Hanford) Building is classified as a limited-control facility for criticality safety.

To the north of the 306W Building and 9 m (30 ft) to the east of the 3716 Building is a 500 gal above-ground propane storage tank (see Figure 2.2.2-2). The tank provides a propane supply to the Battelle PNL 306W Building. The tank has been inspected and appears to be within the standard Department of Transportation requirements for flammable gases. The tank has four inch steel legs and stands on a concrete pad. It is located on the side of the facility where traffic is infrequent; the only identified need for vehicle traffic would be for the purpose of filling the tank. It is anticipated that if the approximately 5/8 inch copper tubing line from the tank were to break, the flow would be adequately restricted so that large amounts of gas would not collect for a major fire or explosion. Flames would be more like a torch out of the tubing. There are no identified ignition sources in the vicinity of the tank; electrical lines in the vicinity are underground. The frequency of fires used in the Accident Analysis (Johnson 1994) and the Fire Criticality Probability Analysis (Kelly 1995) encompasses fires associated with the tank.

313 North Building

The north end of the 313 Building is under the control of a private company (Kaiser Aluminum) that is fabricating specialty metal parts, as was discussed in Section 2.2.2. Although the building occupants are employed by Kaiser Aluminum and are private employees, because they are leasing a DOE facility, they are considered site workers. However, no radiological or hazardous material operations are being performed within the facility. The large metal extrusion press located in the 313 Building is used to extrude metal shapes for commercial use. The fabricator will be extruding ~ 450 kgs (990 lbs) magnesium (Mg) billets. The Mg billets will be in a hard, solid form. Approximately 10 lbs of chips and cuttings will be produced from the sawing operation. The saw cuttings will be vacuum recovered during the cutting operations and deposited in a 55 gallon drum. The drum will comply with Class D fire suppression and all WISHA and Washington State OSHA requirements.

To the north of the building are two 1000 gallon above-ground propane storage tanks which were recently (December 1994) installed to current standards for area heating and also to provide heat for the extrusion press. This is the only major energy source at the facility which could significantly impact the adjacent fuel supply building. An accident analysis was specifically prepared for the propane tanks which is discussed in Section 3.1.3.1.2.

3.0 INTERIM SAFETY BASIS EVALUATION

3.1 HAZARD ANALYSIS

3.1.1 Hazard Categorization

A hazard categorization (Brehm 1995) has been prepared for the facility in accordance with DOE-STD-1027-92 resulting in the assignment of Hazard Category 3 for FSS.

In developing a hazard categorization, the DOE-STD-1027-92 standard allows for either direct use of the inventory values in the standard; or, an alternate method using a credible release fraction of oxidized uranium to modify inventory values identified in the standard and comparing facility-specific radionuclide values to them. The hazard categorization was prepared based on a conservative, credible release fraction ($1.45E-4$) for the facility using facility-specific values for individual radionuclides and comparing them with modified Category 2 values, as identified in Table 3.1.1-1.

The radiological source term used for the hazard categorization was a uranium inventory of 1122 MTU, the maximum quantity of uranium in a single building (3712 Building) available for release. Facility segmentation is permitted by DOE-STD-1027-92, as long as the hazardous material in one segment (or building) could not interact with the hazardous material in other segments (or buildings). Since the heating, ventilation, and air conditioning (HVAC), piping, fire protection (sprinkler), etc., systems are independent among the various fuel storage buildings (i.e., there are no HVAC or process piping systems in these buildings that could allow hazardous material interaction), and there is significant physical separation between the buildings, independence is demonstrated for facility segmentation purposes.

Table 3.1.1-1. 3712 Building Radionuclide Inventory Compared to Category 2 and Modified Category 2 Values.

RADIONUCLIDE	3712 BUILDING INVENTORY (Ci)	CATEGORY 2 VALUES (Ci) ⁽¹⁾	MODIFIED CATEGORY 2 VALUES (Ci) ⁽²⁾
Uranium-234	650.8	2.2 E+02	1.52 E+03
Uranium-235	30.3	2.4 E+02	1.65 E+03
Uranium-236	52.7	5.5 E+01	3.79 E+02
Uranium-238	392.7	2.4 E+02	1.65 E+03
Technetium-99	190.7	3.8 E+06	2.62 E+07

(1) DOE-STD-1027-92

(2) Brehm 1995

As shown in Table 3.1.1-1, the facility radionuclides are below the modified values for a Category 2 facility. Therefore, the facility is assigned a hazard categorization of Nuclear Facility Category 3. Only those

buildings within the facility that store fuel materials or are intended to support limited fuel handling or packaging (333 Building) are designated Category 3 buildings. All others are designated Radiological buildings (see Table 2.2.1-1).

3.1.2 Potential Accident Scenarios

A hazard analysis (Johnson and Brehm, 1994) has been prepared for the facility in compliance with the requirements of WHC-CM-4-46. The hazard analysis process included the formation of a team of knowledgeable Westinghouse Hanford individuals from the facility and the safety analysis organizations. The team systematically reviewed the facility for all energy sources, potential event scenarios, target consequences, and identified the following range of potentially hazardous event scenarios for further analysis of onsite and offsite dose consequences:

1. Ignition of residual uranium/Zircaloy-2 manufacturing chips and fines during facility and equipment cleanout,
2. Leakage or dryout of water in uranium/Zircaloy-2 chips and fines storage drum that exposed the chips and fines to air, resulting in spontaneous combustion,
3. Ignition of HEPA filter containing uranium, Zircaloy-2, and beryllium metals and compounds during filter removal,
4. Ignition of the uranium/Zircaloy-2 chips and fines that have been imbedded in concrete in a storage drum,
5. Seismic or other induced fire in uranium fuel storage building with fire protection system or Hanford Fire Department mitigation,
6. Seismic or other induced fire in uranium fuel storage building without mitigation, and
7. Multiple fuel stacking errors with introduction of optimum moderation.

Since the hazard analysis has been prepared, the first two event scenarios are no longer applicable: ignition of residual uranium/Zircaloy-2 chips and fines, and leakage or dryout of water in uranium/Zircaloy-2 chips and fines storage drums. The non-concreted chips and fines are no longer present at the facility and will not be addressed. Also, an additional event scenario, large propane storage tanks explosion, has been analyzed, and a summary is provided in Section 3.1.3.1 under fire propagation.

3.1.3 Analysis of Significant Accidents/Events

Safety analyses (Johnson 1994) have been performed for the facility to establish a technical justification for the Interim Safety Basis (ISB) conclusion that the facility does not represent an undue risk to the public,

employees, or the environment. In addition, the analysis provides a basis for the Facility Interim OSRs.

The accidents identified in Section 3.1.2 were analyzed (Johnson 1994), and those with the potential for a higher overall risk are listed below and summarized in this section:

- Seismic or other induced fire in uranium fuel storage building with fire protection system or Hanford Fire Department mitigation (Section 3.1.3.1),
- Seismic or other induced fire in uranium fuel storage building without mitigation (Section 3.1.3.1), and
- Multiple fuel stacking errors with introduction of optimum moderation (Section 3.1.3.2).

The additional event identified in Section 3.1.2, large propane storage tank fire, is discussed in Section 3.1.3.1, below, under fire propagation.

The remaining bounded accidents listed below, but no longer applicable to the facility, are discussed in detail in the analysis (Johnson 1994). No further discussion will be made of these bounded accidents in this document.

- Ignition of HEPA filter containing uranium, Zircaloy-2, and beryllium metals and compounds during filter removal,
- Ignition of the uranium/Zircaloy-2 chips and fines that have been imbedded in concrete in a storage drum.

Based on the supporting analyses and the following discussion, it is concluded that storage and handling of uranium in the facility and cleanup and transition activities required for permanent closure and shutdown are well within the WHC-CM-4-46 Risk Acceptance Guidelines.

3.1.3.1 Fire Radiological and Toxicological Analysis.

3.1.3.1.1 3712 Building Fire. Accidents with significant dose consequences are those involving uranium fires or exposure of uranium to fires and the associated uranium oxidation. Both onsite and offsite radiological dose and toxicological consequences were analyzed for several credible fire events, all involving an unmitigated fire (i.e., no fire suppression) in a uranium storage building. The consequences for the maximum credible event, an 8-hour fire, were determined to be 3.9 rem onsite and 250 mrem offsite for radiological consequences, and $Be = 1.35 \mu\text{g}/\text{m}^3$, $U = 3.1 \text{ mg}/\text{m}^3$ onsite and $Be = 0.091 \mu\text{g}/\text{m}^3$, $U = 0.21 \text{ mg}/\text{m}^3$ for offsite toxicological consequences. These radiological and toxicological consequences result in less than Guidelines Consequences that would require Engineered Safety Features as shown in Table 1.6-1.

The bounding fire in the 3712 Building, which formerly contained 1122 MTU, is described in the accident safety analysis (Johnson 1994). This analysis is based on conservative uranium release fractions and assumptions and does not take credit for the uranium oxidation protection that would be

provided by the Zircaloy-2 cladding on the finished fuel assemblies. Nor does it take credit for actuation of the building automatic fire alarm or sprinkler system or prompt fire fighting action by the Hanford Fire Department. The analysis used the combustible loading (wood, cardboard, plastics, etc.) associated with the specific 1122 MTU loading in the building at the time of the survey. The combustible loading provided a basis for calculating a fire load density (Btu/ft²) which established a fire duration and maximum temperature. The fire duration and temperature were then used to establish the fraction of the uranium inventory that was oxidized and subject to release. This quantity yielded the radiological and toxicological dose consequences noted earlier.

Although the 303-B Building has a higher combustible loading than the 3712 Building (357,287 Btu/ft² vs 197,173 Btu/ft²) and a more severe fire is predicted, the release is less because of its lower uranium inventory.

Potentially exceeding the 3.9 Rem (onsite) dose is precluded by maintaining the Criticality Prevention Specifications that limit storage box stacking heights and require storage box access to verify labeling, and by the uranium fuel inventory requirements that also require aisles between storage boxes to allow contents verification. Any modification or reconfiguration with potential to increase the combustible loading density must be evaluated if the uranium inventory is greater than 89.9 MTU to ensure the limits of 5.0 Rem onsite and 0.5 Rem offsite would not be challenged by a basis fire. (89.9 MTU, if completely oxidized, results in the 3.9 Rem dose.) Any additional evaluations are to be performed using the same technical basis used in the original analysis (Johnson 1994) and the results included in the annual update of this ISB.

3.1.3.1.2 Fire Propagation Between Fuel Storage Buildings - Large Propane Storage Tank Fire. A metals fabricator will utilize the large metal extrusion press located in the 313 Building as a private industry venture. Liquefied petroleum gas (LPG) will be used to heat the building and also to provide heat for the extrusion press. A review of the propane tank storage and operations indicated that three propane related events should be evaluated as follows: (1) a Boiling Liquid, Expanding Vapor Explosion (BLEVE), (2) a propane leak and explosion/deflagration in the 313 Building, and (3) uncontrolled venting at a tank resulting in a release of combustible gas (Brehm et al. 1995). An analysis was prepared to assess the impact that the propane tank operation events would have on the 3712 and 3716 fuel storage buildings. The analysis assumed installation of two each, 2000-gallon storage tanks. The contractor actually installed two each, 1000-gallon storage tanks, placed at the north end of the 313 Building, at least 25 feet from the building.

Results of the analyses indicate that the order of consequence for the three events is (1) BLEVE, (2) explosion/deflagration in the 313-North Building, and (3) uncontrolled vent leak.

The potential consequences and/or probability of a BLEVE at a 2000-gallon propane supply tank or a 3000-gallon propane delivery truck tank at the north end of the 313 Building were evaluated as to the potential for either event to initiate a fire in either or both the 3712 or 3716 uranium fuel storage buildings. In evaluating data on BLEVEs published by the National Fire

Protection Association, it was concluded that an intense heat source is necessary to initiate a BLEVE, such as a vehicle fire during filling of the tank. The probability of the initiating event was determined to be $9.75 \text{ E-}08$, which is considered an incredible event. Therefore, the conclusion of the BLEVE analysis is that the risk is within acceptable guidelines identified in WHC-CM-4-46, *Safety Analysis Manual*, Section 7.0, "Risk." Propagation of a fire between two of the fuel storage buildings containing the largest quantities of fuel, a common mode event, is also considered incredible because of the incredible probability of the initiating event.

The second accident evaluated was that of a slow propane leak inside the 313-North Building during a nonoperational period. Results of this analysis indicate that a leak would have to go undetected for at least 10 hours to produce an explosion large enough to heavily damage the 3712 Building, while the 3716 Building would suffer only cosmetic damage. The potential for a fire being initiated in either or both of the buildings as a result of a gas explosion is very small, since the flash would be of short duration.

Evaluation of the third potential event, ignition of a venting liquified petroleum gas storage tank, concluded that there are no hazardous consequences.

Two additional LPG storage tanks have been reviewed: a 500-gallon tank east of the 3716 Building and an underground tank north of the 3712 Building and South of the 3720 Building. Both tanks are owned by PNL. The underground tank has not been in use for several years and is not scheduled to be placed in service. Both tanks are bound by the analyses prepared for the LPG storage tanks to be used by the metal fabricator.

3.1.3.2 Criticality Analysis.

3.1.3.2.1 Criticality Accident Scenarios. All fissionable materials (feed material, i.e., billets, fuel components, fuel assemblies, and scrap) are handled and stored according to Criticality Prevention Specifications (CPS) that ensure at least two unlikely and independent contingencies must occur before criticality is possible. The CPS limits consider the specific enrichment and physical characteristic of each type of fissionable material in the facility. For handling, the quantity of fissionable material is limited to the hemispherical safe mass (i.e., half the minimum mass corresponding to $k_{\text{eff}} = 0.98$). For storage, the CPS limits are based on areal density and potential moderation/reflection under accident conditions.

Use of the hemispherical safe mass limit for handling activities addresses all handling and packaging accident scenarios. The hemispherical safe mass values assume optimum spacing, moderation, and full reflection to obtain true minimum values (Schwinkendorf 1995). These conditions could be achieved by a fire that destroyed the container and resulting flooding from fire suppression efforts. Even under these conditions, the configuration is safe unless it is more than double batched. Because moderation and reflection are necessary to achieve a criticality, no human error or combination of human errors by themselves, i.e., CPS noncompliance, can result in criticality.

Storage of N Reactor fuel and feed materials has been analyzed and found to be subcritical under all credible accident scenarios (Schwinkendorf 1995).

All fuel storage arrays are substantially subcritical if mis-stacked, even double stacked. Similarly, all fuel storage arrays are substantially subcritical if optimally moderated. Combining contingencies of mis-stacking and introduction of optimum moderation still produces configurations with substantial margins of subcriticality.

Criticality is possible only if at least three contingencies are exceeded (Schwinkendorf 1995). Criticality requires the following:

- a) Mis-stacking: The array of fuel storage boxes is significantly mis-stacked, i.e., to where it becomes the equivalent of an infinite array of the incorrect stacking.
- b) Reconfiguration: The array of fuel assemblies within the storage boxes collapses, resulting in a lattice of fuel assemblies that do not touch, but are in a lattice providing optimum spacing. A fire that destroyed the storage boxes could conceivably accomplish this.
- c) Moderation: The collapsed array of fuel assemblies is optimally moderated. Presumably, fire suppression efforts could approximate this condition.
- d) Reflection: The moderated collapsed array is optimally reflected. This could be achieved by water that completely covered the collapsed array. This water could also result from fire suppression efforts. Blockage of the facility drains, allowing sufficient depth to accumulate, represents the third contingency.

The unlikely contingencies are 1) mis-stacking, 2) a fire that consumed the storage containers (collapsing the array) and provided moderation through mitigation efforts, and 3) blocking of the storage building drains that allowed sufficient water accumulation to completely cover the array and provide the necessary reflection.

The Mark IA fuel assembly bare slab height for $k_{eff} = 0.98$, i.e., the value for the collapsed and optimally moderated but unreflected fuel assemblies, is 17.3 inches. The height of the optimally spaced Mark IA slab array resulting from collapsed mis-stacked storage boxes (three high) is 17.5 inches - essentially at the height corresponding to $k_{eff} = 0.98$. (A bare slab height of 18.2 inches corresponds to $k_{eff} = 1$.) For Mark IV fuel assemblies, a bare slab height of 23.4 inches corresponds to $k_{eff} = 0.98$. The height of the optimally spaced Mark IV slab array resulting from collapsing a mis-stacked array (four high for Mark IV) is 23.0 inches. Except for essentially infinite arrays, moderated and reflected configurations of fuel assembly components are less reactive than identical configurations of fuel assemblies. Thus, the accident conditions involving unfinished fuel are bounded by the fuel assembly analyses.

Conservatism in the criticality calculations include:

- a) Mis-stacking must involve many adjacent stacks of storage boxes. Partial mis-stacking, e.g., four out of five, results in an array well within the $k_{eff} = 0.98$ criterion.

- b) No credit is taken for the neutron absorbing characteristics of the storage box metal fasteners and impurities in the wooden storage boxes.

3.1.3.2.2 Criticality Probability. Although Criticality is possible as described above, it is not credible. Probabilities of necessary contingencies are discussed below. Although the focus of the probability analysis is on the storage mode (Kelly 1995), it also applies to the handling mode because criticality is impossible unless mishandling creates an ideal configuration that is subsequently subject to fire, moderation, and reflection.

Mis-stacking

Criticality Prevention Specification limits on fuel storage box stack heights preclude accumulation of sufficient fissionable material that could theoretically become critical following potential subsequent events. (The most reactive Mark IA fuel assemblies are restricted to two-high stacks of storage boxes. Mark IV fuel assembly storage boxes are limited to three-high stacks. One outer fuel element may be substituted in the place of a single fuel assembly. All containers are rigorously labeled.) Many adjacent stacks must be affected to approximate the equivalent of an infinite array. At a minimum, this corresponds to a four-by-four array that would require at least sixteen errors. All fuel movements are supervised; unauthorized fuel movement is prevented by the storage buildings being locked. Periodic inspections of fuel storage facilities are performed to assure compliance with stacking requirements. A probability of $1.0 \text{ E-}4$ is assigned to this contingency, based on rigorous oversight associated with all fuel movements.

Reconfiguration

Removal of the storage boxes and collapse of the fuel assemblies could result only as a consequence of a fire. Facility history review over the last 25 years resulted in an annual fire probability of $1.6 \text{ E-}1$. A seismic induced fire has a smaller probability ($5.5 \text{ E-}6$) because of the combination of the earthquake probability and engineering judgements regarding the probability of consequent fire reaching the fuel storage boxes. Although fuel assembly collapse into a lattice with near optimum separation is improbable, a probability of unity was assumed for that aspect of reconfiguration because of the difficulty of assigning a specific reconfiguration mechanism.

Moderation

Fire mitigation efforts, whether from the automatic dry-pipe fire suppression system or from the Hanford Fire Department, could add sufficient water to moderate the collapsed array. This corresponds to a depth of at least 17.3 inches. A probability of $1.0 \text{ E-}1$ is assigned despite the likely presence of ash and other debris that would interfere with optimum moderation. A slightly higher probability was assigned for moderation resulting from a seismically induced fire ($2.5 \text{ E-}1$) because of the likelihood of the automatic fire suppression system water supply breaching in the vicinity of the fire.

Reflection

Adding additional water is necessary to achieve criticality. Drainage of fire suppression water is assured by multiple built-in floor level drains

and/or flexible baffles at the bottom of large roll-up doors designed to drain that quantity of water that could be released by credible fire suppression efforts. Although drains are regularly inspected to assure availability, probabilities of $1.0 \text{ E-}3$ are assigned for the random fire event and $5.0 \text{ E-}1$ for the seismic induced fire. Probability of drain failure is more likely following a seismic event because of the increased quantity of debris that could interfere.

Overall probability for criticality resulting from a random fire is $1.6 \text{ E-}9$. The corresponding probability for a criticality resulting from a seismic induced fire is $6.9 \text{ E-}11$. Both values are substantially less than $1.0 \text{ E-}6$, which is the threshold for credibility. No other scenario is postulated that could result in criticality. Therefore, per DOE 5480.24, a criticality detection and alarm system (CAS) is not required.

3.1.4 Risks

The consequences of accidents and events summarized in Section 3.1.2 are based on analyses reflecting the current facility configuration and follow-on transition and shutdown activities. The accident dose consequences analysis was made using site specific meteorology, and the current Hanford Environmental Dose Overview Panel (HEDOP) accepted GENII analysis code/version, and the results have been approved by an independent HEDOP reviewer. Criticality calculations have been performed using modern computer codes that comply with Software Quality Assurance (SQA) requirements. Therefore, the consequences of the accidents and events are considered valid. Based on the supporting analyses and the evaluations presented in Section 3.1.3 above, it is concluded that current and future facility operations bound by this ISB are well within the WHC-CM-4-46 Risk Acceptance Guidelines.

3.2 HAZARD CONTROLS

3.2.1 Safety Structures, Systems and Components

3.2.1.1 Safety Class 1 and 2 Structures, Systems, and Components. Accidents with significant dose consequences have been analyzed (Johnson 1994) (see Section 3.1.3). Since the maximum releases (3.9 rem EDE for onsite radiological consequences, and $\text{Be} = 1.35 \mu\text{g}/\text{m}^3$ and $\text{U} = 3.1 \text{ mg}/\text{m}^3$ for onsite toxicological concentrations), fall below the Safety Class 1 and 2 lower limits, no Safety Class 1 or 2 structures, systems, or components are required. This Safety Class determination is based on the fire loading of the 3712 Building and the associated worst case fire possible (8 hr) for the facility. Refer to Table 1.6-1 for Safety Class categories and associated criteria and calculated radiological consequences and toxicological concentrations for the maximum facility release (8-hr fire in 3712 Building).

3.2.1.2 Design Features. Configuration features that are directed at further reducing the probability of a criticality and reducing dose consequences associated with accidents are described below.

Facility Water Drainage (see Figures 2.2.2-3, 2.2.1-11, and 2.2.1-12). The fuel storage buildings contain features that would drain water to the outside ground and prevent accumulation of sufficient water to provide reflection of the reconfigured fuel assemblies resulting from a fire. Because this reflection represents a third contingency necessary for criticality (Schwinkendorf 1995), and the probability of criticality is essentially incredible without taking credit for the drains (Kelly 1995), these configuration features are not considered to be Safety Class 1 or 2 items, but do provide additional contingency.

3.2.1.3 Facility Degradation. The facility structures, systems, and components and, in particular, some of the building roofs, have suffered some degradation. Failure of the structures and components has the potential for changing the fuel spacing, impacting the building drainage ports, and/or failing the fire protection system. The structures and components (e.g., fire protection, electrical, etc.) are not required to be Safety Class 1 or 2 for the following reasons:

- The criticality safety analysis considers optimum moderation (the potential result of structure failure failing the fire protection system causing introduction of water, and plugging the drainage ports preventing escape of the water) and changes in the fuel lattice (the potential result of the structure falling onto the storage boxes),
- The fire criticality probability analysis considers the probability of introduction of water, prevention of escape of the water, and changes in fuel storage geometry with the systems and structures not being Safety Class 1 or 2, and
- The facilities do not have confinement systems. The structures are essentially open to the atmosphere, and their failure would not significantly change the ability to contain releases. The accident safety analysis does not take credit for confinement.

Facility construction and the building layouts are included in Section 2.2.2.

3.2.1.4 Control and/or Mitigation of Structure, System, and Component Deficiencies. This requirement is considered not applicable, since there are no Safety Class 1 or 2 structures.

3.2.2 Administrative Controls

The existing OSRs that were applicable to the operation of the fuel fabrication facility are contained in WHC-CM-5-31. All manufacturing operations have been discontinued, and all uranium fuel materials have been placed in storage with only limited handling permitted. Exhaust systems have been shut down and blanked off. With the change in facility mission, the existing OSRs defined by WHC-CM-5-31 are no longer applicable to the present fuel storage mode and cleanup activities and will be removed with DOE approval.

Figure 3.2.1-2. Fuel Scrap Storage and Shipment Box.

DOT 7A Type A
49CFR 178.350
NLO Family of Banded, Wooden Boxes

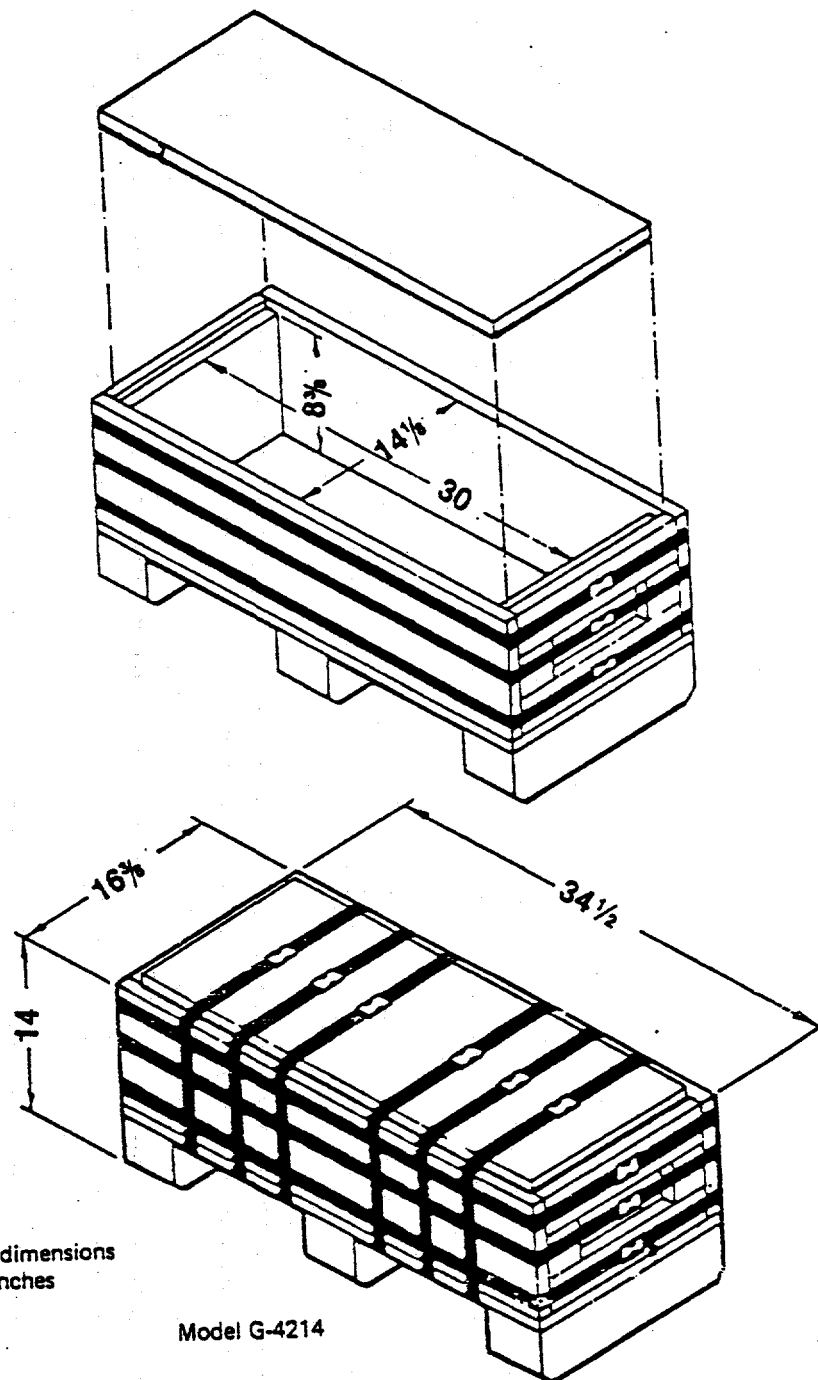
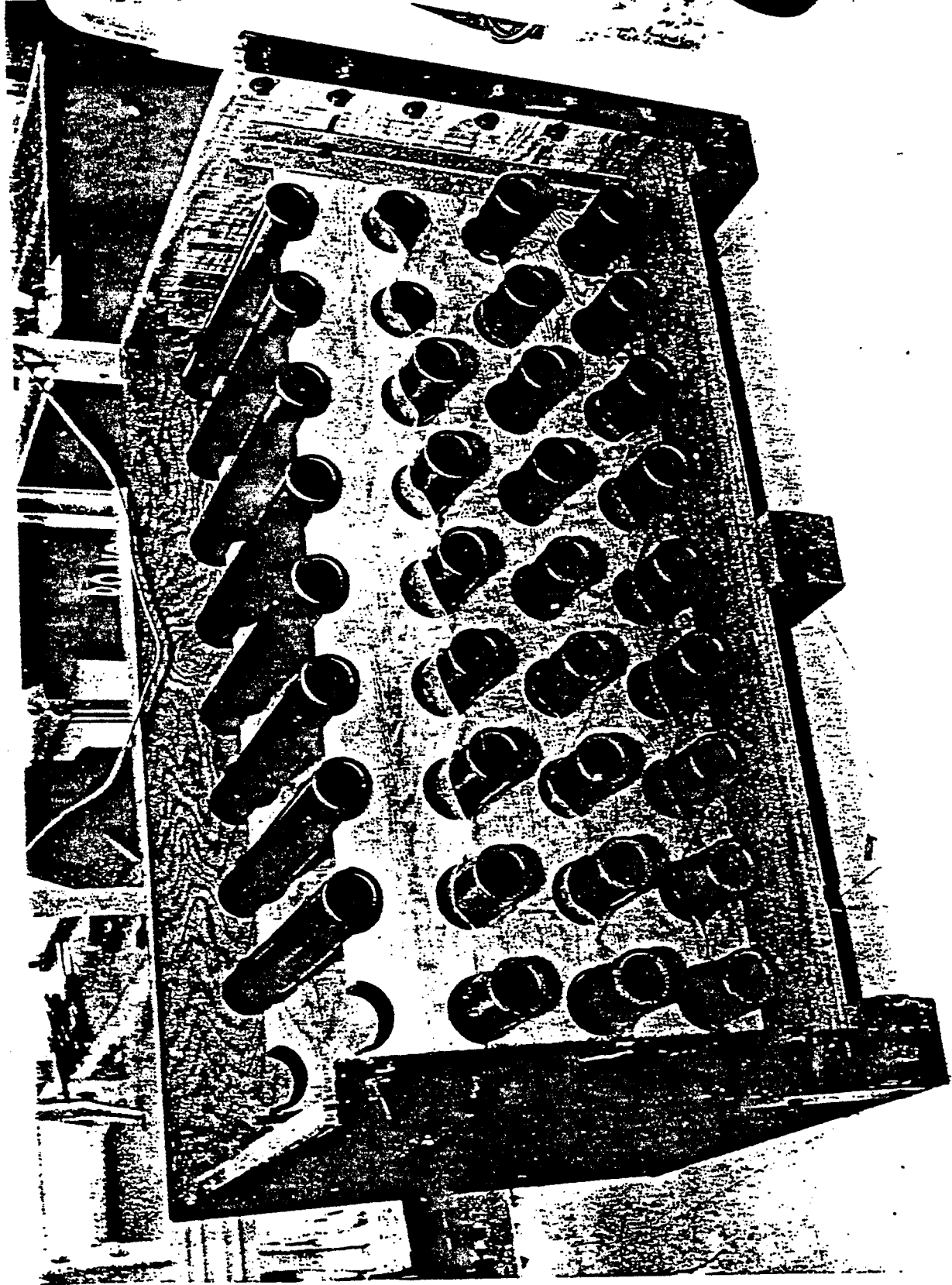

Figure 3.2.1-3. Finished Fuel Storage and Shipment Box.



Upon approval, this ISB defines the safety envelope for the remainder of the facility mission until turnover for D&D.

The new Interim OSRs for Operation for the facility define acceptable conditions, safe boundaries, bases thereof, and management or administrative controls required to ensure safe fuel storage and transition activities of the facility. The scope of the Interim OSRs is limited to maintaining the safety envelope as defined by this ISB.

The format and content of the Interim OSRs are based on DOE Order 5480.22 on TSRs. The Interim OSRs and appendices constitute an agreement or contract between DOE and Westinghouse Hanford regarding the safe operation of the facility. As such, the Interim OSRs cannot be changed without the approval of the DOE Program Secretarial Officer (PSO), or designee. The scope of the Interim OSRs is based on this facility ISB document.

Administrative controls that provide assurance of maintaining the safety envelope are as follows:

- Limiting fuel handling to quantities less than the minimum hemispherical safe mass quantities.
- Maintaining compliance with Criticality Prevention Specifications, including performing periodic surveillance of uranium storage building drain systems.
- Maintaining control of storage building combustible material and uranium inventories.

3.2.3 Institutional Safety Programs

Safety programs are identified in Section 4.0.

3.3 SUMMARY

It is concluded that the risk associated with the current and planned operational mode of the facility, (uranium storage, cleanup, and transition activities, etc.) are within Risk Acceptance Guidelines. The facility is assigned a hazard categorization of Category 3, since the inventory available for release is greater than the facility-specific recalculated Category 3 threshold quantities (TQs), but less than the recalculated Category 2 TQs. The dose and toxicological consequences for a range of credible fires, from a concretion drum fire to a uranium storage building fire, have been analyzed using current Hanford and Westinghouse Hanford accepted methods. The radiological and toxicological consequences for the maximum credible event are less than Guidelines Consequences that would require Engineered Safety Features (Safety Class 1 or 2 items).

It is also concluded that because of the incredible probability for a nuclear criticality, a criticality alarm system (CAS) is not required as allowed by DOE Order 5480.24.

4.0 HANFORD GENERIC AND FACILITY PROGRAMS

The Hanford Generic Institutional Controls and Safety Programs assure operation of the facility in a configuration that supports the defined safety envelope by addressing the following:

- Configuration Management
- Occurrence Reporting
- Criticality Safety

Additional Hanford Generic Institutional Controls and Safety Programs assure maintenance of the facility in a configuration that supports worker safety by addressing the following:

- Radiation Protection
- As Low As Reasonably Achievable (ALARA)
- Occupational Safety
- Fire Protection
- Industrial Safety
- Industrial Hygiene
- Training
- Radioactive Waste Management
- Quality Assurance
- Conduct of Operations
- Emergency Planning
- Environmental Protection

The Hanford Generic Institutional Controls or Safety Requirement, and corresponding DOE Orders and Titles, and the Applicable WHC Controlled Manuals are contained in Table 4.0-1, columns 1, 2, and 3.

The facility-specific safety and control programs are in the process of being developed and are included in WHC-CM-5-35 Fuels Supply Operations Control Manual. The fourth column of Table 4.0-1 contains facility specific procedures and controls issued, planned, or potentially planned that are fully or partially responsive to the institutional control or safety requirement, DOE Order and title, and applicable WHC control manual in the first three columns. The degree of responsiveness is based on facility specific needs.

Table 4.0-1. Identification of Institutional Control or Safety Requirement, DOE Orders and Titles, WHC Control Manuals and Fuel Supply Shutdown-Specific Implementing Documentation.

INSTITUTIONAL CONTROL OR SAFETY REQUIREMENT	DOE ORDER/TITLE	APPLICABLE WHC CONTROL MANUAL	FUEL SUPPLY SHUTDOWN FACILITY-SPECIFIC PROCEDURES
Radiation Protection	<p>5400.5, <u>Radiation Protection of the Public and the Environment</u></p> <p>5484.4, <u>Environmental Protection, Safety, and Health Protection Standards</u></p> <p>10 CFR 835, <u>Occupation Radiation Protection</u></p>	<p>WHC-CM-1-3, <u>Management Requirements and Procedures</u></p> <p>HSRCM-1, <u>Hanford Site Radiological Control Manual</u></p> <p>WHC-CM-4-11, <u>ALARA Program Manual</u></p> <p>WHC-CM-7-5, <u>Environmental Compliance Manual</u></p> <p>HSRCM-1, <u>Hanford Site Radiological Control Manual</u></p> <p>WHC-CM-4-11, <u>ALARA Program</u></p>	<p>The facility operation conforms to the Hanford Site Radiological Control Program manual. Facility-specific Radiation Work Permits (RWP) that conform to the HSRCH requirements are prepared and abided by.</p>
ALARA	<p>5480.11, <u>Radiation Protection for Occupational Workers</u></p>	<p>WHC-CM-4-11, <u>ALARA Program</u></p>	<p>The facility operation conforms to the HSRCH. No additional facility-specific procedures are considered necessary. An ALARA point of contact has been designated.</p>
Occupational Safety	<p>5483.a, <u>Occupational Safety and Health Program for DOE Contractor Employees at Government-owned Contractor-operated Facilities</u></p>	<p>WHC-CM-1-3, <u>Management Requirements and Procedures</u></p> <p>WHC-CM-4-2, <u>Quality Assurance Manual</u></p> <p>WHC-CM-4-3, <u>Industrial Safety Manual</u></p> <p>WHC-CM-4-40, <u>Industrial Hygiene Manual</u></p>	<p>WHC Controlled Manual Programs provide the controls that are conformed to, to assure personnel occupational safety. No additional facility-specific procedures are considered necessary.</p>
Fire Protection	<p>5480.7, <u>Fire Protection</u></p>	<p>WHC-CM-1-3, <u>Management Requirements and Procedures</u></p> <p>WHC-CM-4-41, <u>Fire Protection Manual</u></p>	<p>WHC Controlled Manual Program provides the controls that are conformed to, to assure fire protection. Facility-specific Pre-fire plans have been established and are maintained to aid the Hanford Fire Department.</p>
Industrial Safety	<p>5483.1A, <u>Occupational Safety and Health Program for DOE Contractor Employees at Government-owned Contractor-operated Facilities</u></p>	<p>WHC-CM-1-3, <u>Management Requirements and Procedures</u></p> <p>WHC-CM-4-2, <u>Quality Assurance Manual</u></p> <p>WHC-CM-4-3, <u>Industrial Safety Manual</u></p> <p>WHC-CM-4-40, <u>Industrial Hygiene Manual</u></p>	<p>The WHC Controlled Manual Program provides the controls that are conformed to, to assure personnel industrial safety. The facility-specific procedures WHC-CM-5-35 FUELS SUPPLY OPERATIONS CONTROL MANUAL, Procedure 09-01, Fuel Supply Lock and Tag, has been established and is being implemented.</p>
Industrial Hygiene	<p>5480.10, <u>Contractor Industrial Hygiene Program</u></p>	<p>WHC-CM-1, <u>Company Policies and Charters</u></p> <p>WHC-CM-1-3, <u>Management Requirements and Procedures</u></p> <p>WHC-CM-4-3, <u>Industrial Safety Manual</u></p> <p>WHC-CM-4-40, <u>Industrial Hygiene Manual</u></p>	<p>WHC Controlled Manual Programs provide the controls that are conformed to, to assure personnel occupational safety. No additional facility-specific procedures are considered necessary.</p>

INSTITUTIONAL CONTROL OR SAFETY REQUIREMENT	DOE ORDER/TITLE	APPLICABLE WHC CONTROL MANUAL	FUEL SUPPLY SHUTDOWN FACILITY-SPECIFIC PROCEDURES
Criticality Safety	5480.24, <u>Nuclear Criticality Safety</u>	WHC-CM-4-29, <u>Nuclear Criticality Safety Manual</u>	The WHC Controlled Manual Program provides the controls that are conformed to, to assure criticality safety. Facility-specific controls are embodied in the Criticality Prevention Specifications. A facility-specific Criticality Safety Representative has been designated and trained in accordance with WHC-CM-4-29.
Training	5480.20, <u>Personnel Selection, Qualification, Training, and Staffing Requirements at DOE Reactor and Non-Reactor Nuclear Facilities</u>	WHC-CM-2-15, <u>Training Administration Manual</u>	The WHC Controlled Manual Program provides the controls that are conformed to, to assure overall personnel training. Facility-specific procedure WHC-CM-5-35, Procedure 05-01, Fuel Supply Training Plan, provides for implementation of overall and specific training requirements.
Radioactive Waste Management	5820.2A, <u>Radioactive Waste Management</u>	WHC-CM-1, <u>Company Policies and Charters</u> WHC-CM-1-3, <u>Management Requirements and Procedures</u> WHC-CM-2-14, <u>Hazardous Material Packaging and Shipping</u> WHC-CM-5-16, <u>Solid Waste Management</u> WHC-CM-7-5, <u>Environmental Compliance Manual</u>	WHC Controlled Manual Programs provide the controls that are conformed to, to assure acceptable waste management. Facility-specific controls that are established and implemented include WHC-CM-5-35, Procedure 01-06, Administrative Controls for Hazardous, Mixed and Radiological Wastes and Materials, and WHC-SD-NR-PLN-005, Rev. 1, Low Level, Mixed, Hazardous and Non-regulated Waste Certification Plan for Facility Operations/N Reactor Plant/Fuel Supply Facilities, E. A. Weakley, 1993.
Occurrence Reporting	5000.38, <u>Occurrence Reporting and Processing of Operations Information</u>	WHC-CM-1-3, <u>Management Requirements and Procedures</u> WHC-CM-1-5, <u>Standard Operating Practices</u>	WHC Controlled Manual Programs provide the overall controls that are conformed to, to assure acceptable occurrence reporting. A facility-specific procedure, WHC-CM-5-35, Procedure 06-02, Fuel Supply Occurrence Categorization, Notification and Reporting, has been established and implemented.
Quality Assurance	5700.6C, <u>Quality Assurance</u> 10 CFR 830.120, <u>Quality Assurance Program</u>	WHC-CM-1, <u>Company Policies and Charters</u> WHC-CM-1-3, <u>Management Requirements and Procedures</u> WHC-CM-2-1, <u>Procurement Manual and Procedures</u> WHC-CM-3-5, <u>Document Control and Records Management Manual</u> WHC-CM-4-2, <u>Quality Assurance Manual</u>	WHC Controlled Manual Programs provide the controls that are conformed to, to assure acceptable QA. A facility-specific procedure, WHC-CM-5-35, Procedure 01-03, FS QA Records, and QA surveillances are established and implemented.

INSTITUTIONAL CONTROL OR SAFETY REQUIREMENT	DOE ORDER/TITLE	APPLICABLE WHC CONTROL MANUAL	FUEL SUPPLY SHUTDOWN FACILITY-SPECIFIC PROCEDURES
Configuration Management	<p>4330.48, <u>Maintenance Management Program</u></p> <p>5480.21, <u>Unreviewed Safety Questions</u></p> <p>5480.22, <u>Technical Safety Requirements</u></p> <p>5480.23, <u>Nuclear Safety Analysis Reports</u></p> <p>5480.19, <u>Conduct of Operations Requirements for DOE Facilities</u></p>	<p>WHC-CM-1-3, <u>Management Requirements and Procedures</u></p> <p>WHC-CM-4-46, <u>Safety Analysis Manual</u></p> <p>WHC-CM-6-1, <u>Standard Engineering Practices</u></p> <p>WHC-CM-1-8, <u>Work Management</u></p>	<p>WHC Controlled Manual Programs provide the overall controls that are conformed to, to assure acceptable configuration management. Facility-specific controls that are being established and implemented include WHC-CM-5-35, Procedure 02-01, Fuel Supply Job Control System, and the Interim OSRs (Besser 1995).</p>
Conduct of Operations	<p>5500.28, <u>Emergency Categories, Classes, and Notification and Reporting Requirements</u></p> <p>5500.3A, <u>Planning and Preparedness for Operational Emergencies</u></p>	<p>WHC-CM-1, <u>Company Policies and Charters</u></p> <p>WHC-CM-1-5, <u>Standard Operating Practices</u></p>	<p>A facility-specific graded approach to conduct of operation has been developed and agreed to between WHC and DOE-RL, and is being implemented: Correspondence No. 9361085, CONDUCT OF OPERATIONS GRADED APPROACH APPLICABILITY MATRIX FOR FMEF/308 BUILDING/300 AREA FUEL SUPPLY, J. M. Steffen to J. E. Mecca, December 30, 1993.</p>
Emergency Planning	<p>5400.1, <u>General Environmental Protection Program</u></p> <p>5400.5, <u>Radiation Protection of the Public and the Environment</u></p> <p>5480.4, <u>Environmental Protection, Safety, and Health Protection Standards</u></p> <p>5484.1, <u>Environmental Protection, Safety, and Health Protection Information Reporting Requirements</u></p>	<p>WHC-CM-1, <u>Company Policies and Charters</u></p> <p>WHC-CM-1-3, <u>Management Requirements and Procedures</u></p> <p>WHC-CM-4-1, <u>Emergency Plan</u></p> <p>WHC-CM-4-43, <u>Emergency Management Procedures</u></p> <p>WHC-CM-4-44, <u>Emergency Preparedness Administration</u></p>	<p>The WHC Controlled Manual Programs provide the overall controls that are conformed to, to assure acceptable emergency planning. The facility-specific emergency plan that has been established and is being implemented is WHC-IP-0263-333, Building Emergency Plan for Fuel Supply Facilities.</p>
Environmental Protection	<p>WHC-CM-1, <u>Company Policies and Charters</u></p> <p>WHC-CM-1-3, <u>Management Requirements and Procedures</u></p> <p>WHC-CM-4-2, <u>Quality Assurance Manual</u></p> <p>WHC-CM-4-3, <u>Industrial Safety Manual</u></p> <p>WHC-CM-4-40, <u>Industrial Hygiene Manual</u></p> <p>WHC-CM-7-5, <u>Environmental Compliance Manual</u></p>	<p>WHC Controlled Manual Programs provide the controls that are conformed to, to assure acceptable environmental protection. The facility-specific Facility Effluent Monitoring Plan (FEMP) has been re-evaluated and a FEMP is no longer required. Based on the new FEMP determination, the facility does not require environmental monitoring.</p>	

* Facility-specific procedures 05-01, Fuel Supply Training Plan, and Procedure 01-06, Administrative Controls for Hazardous, Mixed and Radiological Wastes and Materials, will be in place by August 1, 1995. Until the procedure upgrade has been completed, Operations are in accordance with the WHC Generic controls as considered necessary.

5.0 REFERENCES

- DOE, 1991, *Unreviewed Safety Questions*, DOE Order 5480.21, U.S. Department of Energy, Washington, D.C.
- DOE, 1992a, *Technical Safety Requirements*, DOE Order 5480.22, U.S. Department of Energy, Washington, D.C.
- DOE, 1992b, *Nuclear Safety Analysis Reports*, DOE Order 5480.23, U.S. Department of Energy, Washington, D.C.
- DOE, 1992c, *Nuclear Criticality Safety*, DOE Order 5480.24, U.S. Department of Energy, Washington, D.C.
- DOE, 1992d, *Hazard Categorization and Accident Analysis Techniques for Compliance with DOE Order 5480.23, Nuclear Safety Analysis Reports* DOE-STD-1027-92, U.S. Department of Energy, Washington, D.C.
- DOE-RL, 1989, *300 Area Solvent Interim Status Closure Plan*, DOE/RL 88-08, Rev 2, U.S. Department of Energy Richland Field Office, Richland, Washington.
- DOE-RL, 1991, *304 Concretion Facility Closure Plan*, DOE/RL-90-03, U.S. Department of Energy Richland Field Office, Richland, Washington.
- DOE-RL, 1990a, *303-K Radioactive Mixed Waste Storage Facility Closure Plan*, DOE/RL-90-04, Rev 1, U.S. Department of Energy Richland Field Office, Richland, Washington.
- DOE-RL, 1990b, *The 300 Area Waste Acid Treatment System Closure Plan*, DOE/RL-90-11, Rev 0, U.S. Department of Energy Richland Field Office, Richland, Washington.
- NUREG/CR-1278-F, *Handbook of Human Reliability Analysis with Emphasis on Nuclear power Plant Applications (Final Report)*, August 1983, Sandia National Laboratories, Albuquerque, New Mexico.
- WHC-CM-1-3, *Management Requirements and Procedures*, MRP 5.12, "Identification and Resolution of Unreviewed Safety Questions," MRP 5.46, "Safety Classification of Systems, Components, and Structures," Westinghouse Hanford Company, Richland, Washington.
- WHC-CM-1-5, *Standard Operating Practices*, Westinghouse Hanford Company, Richland, Washington.
- WHC-CM-1-8, *Work Management*, Westinghouse Hanford Company, Richland, Washington.
- WHC-CM-2-1, *Procurement Manual and Procedures*, Westinghouse Hanford Company, Richland, Washington.
- WHC-CM-2-14, *Hazardous Material Packaging and Shipping*, Westinghouse Hanford Company, Richland, Washington.

- WHC-CM-2-15, *Training Administration Manual*, Westinghouse Hanford Company, Richland, Washington.
- WHC-CM-3-5, *Document Control and Record Management Manual*, Westinghouse Hanford Company, Richland, Washington.
- WHC-CM-4-2, *Quality Assurance Manual*, Westinghouse Hanford Company, Richland, Washington.
- WHC-CM-4-3, *Industrial Safety Manual*, Westinghouse Hanford Company, Richland, Washington.
- WHC-CM-4-29, *Nuclear Criticality Safety Manual*, Westinghouse Hanford Company, Richland, Washington.
- WHC-CM-4-40, *Industrial Hygiene Manual*, Westinghouse Hanford Company, Richland, Washington.
- WHC-CM-4-41, *Fire Protection Manual*, Section 4.0, "Fire Protection Systems," Westinghouse Hanford Company, Richland, Washington.
- WHC-CM-4-43, *Emergency Management Procedures*, Westinghouse Hanford Company, Richland, Washington.
- WHC-CM-4-44, *Emergency Preparedness Administration*, Westinghouse Hanford Company, Richland, Washington.
- WHC-CM-4-46, *Safety Analysis Manual*, Westinghouse Hanford Company, Richland, Washington.
- WHC-CM-5-16, *Solid Waste Management*, Westinghouse Hanford Company, Richland, Washington.
- WHC-CM-5-31, 1988, *Operations Safety Requirements Fuels 300 Area*, Westinghouse Hanford Company, Richland, Washington.
- WHC-CM-5-35, *Fuels Supply Operations Control Manual*, Westinghouse Hanford Company, Richland, Washington.
- WHC-CM-6-1, *Standard Engineering Practices*, Westinghouse Hanford Company, Richland, Washington.
- WHC-CM-7-5, *Environmental Compliance*, Westinghouse Hanford Company, Richland, Washington.
- WHC-EP-0216, 1989, *Preliminary Operable Units Designation Project*, Westinghouse Hanford Company, Richland, Washington.
- Besser, R. L., 1995, *Fuel Supply Shutdown Facility Interim Operational Safety Requirements*, WHC-SD-NR-TSR-001, Rev. 0, Westinghouse Hanford Company, Richland, Washington (pending approval).

- Brehm, J. R., 1995, *Facility Hazard Categorization for Fuel Supply Shutdown Facility*, WHC-SD-NR-HC-006, Rev. 0, Westinghouse Hanford Company, Richland, Washington (pending approval).
- Brehm, J. R., L. F. Wojdac, and B. E. Hey, 1995, *Risk Assessment for 313 Building Propane Tank Storage and Operation*, WHC-SD-FL-RA-001, Rev. 1, Westinghouse Hanford Company, Richland, Washington (pending approval).
- Dawson, S. A., 1994, *Fuel Supply Facilities Shutdown Plan*, WHC-SD-FL-SSP-002, Rev. 0, Westinghouse Hanford Company, Richland, Washington.
- Frazier, T. P., 1994, *Facility Effluent Monitoring Plan Determinations for the 300 Area Facilities*, WHC-EP-0441, Westinghouse Hanford Company, Richland, Washington.
- Huang, C. H., 1995, *Hazard Classification for 300 Area N Reactor Fuel Fabrication and Storage Facility*, WHC-SD-NR-HC-004, Rev. 0, Westinghouse Hanford Company, Richland, Washington.
- Johnson, D. J., and J. R. Brehm, 1994, *Hazard Analysis for 300 Area N Reactor Fuel Fabrication and Storage Facility*, WHC-SD-NR-PHA-002, Rev. 0, Westinghouse Hanford Company, Richland, Washington.
- Johnson, D. J., 1994, *Accident Safety Analysis for 300 Area N Reactor Fuel Fabrication and Storage Facility*, WHC-SD-NR-RA-003, Rev. 0, Westinghouse Hanford Company, Richland, Washington.
- Kelly, J. E., 1995, *Fire Criticality Probability Analysis for 300 Area N Reactor Fuel Fabrication and Storage Facility*, WHC-SD-NR-TI-051, Rev. 1, Westinghouse Hanford Company, Richland, Washington.
- Myott, C. F., 1994, *Fire Hazards Analysis for 300 Area N Reactor Fuel Fabrication and Storage Facility*, WHC-SD-NR-FHA-001, Rev. 0, Westinghouse Hanford Company, Richland, Washington.
- Myott, C. F., 1995, *Fire Hazards Analysis for 300 Area N Reactor Fuel Fabrication and Storage Facility, Part 2*, WHC-SD-HT-FHA-001, Rev. 0, Westinghouse Hanford Company, Richland, Washington.
- Nickels, J. M., and D. F. Brendel, 1991, *Facility Effluent Monitoring Plan for the 300 Area Fuel Fabrication Facility*, WHC-EP-0509, Westinghouse Hanford Company, Richland, Washington.
- Schwinkendorf, K. N., 1995, *Criticality Safety Evaluation Report for 300 Area N Reactor Fuel Fabrication and Storage Facility*, WHC-SD-NR-CSER-010, Rev. 1, Westinghouse Hanford Company, Richland, Washington (pending approval).
- Weakley, E. A. 1993, *Low Level, Mixed, Hazardous and Nonregulated Waste Certification Plan for Facility Operations/N Reactor Plant/Fuel Supply Facilities*, WHC-SD-NR-PLN-005, Rev. 1, Westinghouse Hanford Company, Richland, Washington.

This page intentionally left blank.