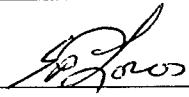
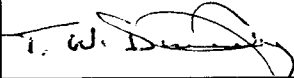

**OFFICE OF CIVILIAN RADIOACTIVE WASTE MANAGEMENT
SYSTEM DESCRIPTION DOCUMENT COVER SHEET**

1. QA: QA
Page: 1 of 72

2. SDD Title
Defense High Level Waste Disposal Container System Description Document

3. Document Identifier (Including Rev. No. and Change No., if applicable)
SDD-DDC-SE-000001 Rev 01 ICN 01

	Printed Name	Signature	Date
4. System Engineer	N. E. Pettit		7/13/01
5. Checker	E. F. Loros		7/13/01
6. Responsible Manager	T. W. Doering		7-13-01

7. Remarks:

This document may be affected by technical product input information that requires confirmation. Any changes to the document that may occur as a result of completing the confirmation activities will be reflected in subsequent revisions. The status of the technical product input information quality may be confirmed by review of the Document Input Reference System (DIRS) database.

The following TBDs/TBVs are contained in this document:

TBD-234; TBD-235; TBD-276

TBV-094; TBV-096; TBV-245; TBV-248; TBV-264; TBV-327; TBV-455; TBV-1246; TBV-4743

**OFFICE OF CIVILIAN RADIOACTIVE WASTE MANAGEMENT
SYSTEM DESCRIPTION DOCUMENT REVISION HISTORY**

1. SDD Title Defense High Level Waste Disposal Container System Description Document	
2. Document Identifier (Including Rev. No. and Change No., if applicable) SDD-DDC-SE-000001 Rev 01 ICN 01	
3. Revision	4. Description of Revision
00	<p>Initial Issue</p> <p>This document is a complete revision of the superseded BBA000000-01717-1705-00002. The document incorporates changes to the "Monitored Geologic Repository Requirements Document," including switching traceability to the "Revised Interim Guidance Pending Issuance of New U.S. Nuclear Regulatory Commission (NRC) Regulations (Revision 01, July 22, 1999), for Yucca Mountain, Nevada." This revision incorporates the "Classification of the MGR Defense High-Level Waste Disposal Container System." This revision incorporates the revision to the "MGR Compliance Program Guidance Package for the Defense High-Level Waste (DHLW) Disposal Container." Changes have been included for the system to comply with management direction put into effect via the "Monitored Geologic Repository Project Description Document."</p>
01	<p>Issued</p> <p>This is a complete revision. Deleted Criteria 1.2.1.5, 1.2.1.7, 1.2.4.1 and 1.2.4.2 and Sections 1.4.1 and 1.4.2 as they were deemed unnecessary by management decision. Added Section 2 (Design Description) to support Site Recommendation. Revised Criteria 1.2.2.1.5, 1.2.2.1.7, 1.2.2.1.12, and 1.2.2.1.13 as a result of updated design information. Added Criteria 1.2.1.22, 1.2.1.23, 1.2.1.24, and 1.2.2.1.14 as a result of new design information. Revised format to eliminate two-volume configuration in conformance with the revised development plan.</p>
01 ICN 01	<p>Added Criterion 1.2.1.7 and revised Criterion 1.2.3.1 to support the Flexible Operations Concept of the MGR. Revised the Quality Assurance statement to include the relevant Technical Work Plan. Updated references "Monitored Geologic Repository Project Description Document" to Rev 02 ICN 02, "Waste Package Design Sensitivity Report" to Rev 01, and "Technical Reports" to Rev 02. Changes made to this document as part of this ICN are indicated by a change bar in the right margin.</p>

DISCLAIMER

This report was prepared as an account of work sponsored by an agency of the United States Government. Neither the United States Government nor any agency thereof, nor any of their employees, nor any of their contractors, subcontractors or their employees, makes any warranty, express or implied, or assumes any legal liability or responsibility for the accuracy, completeness, or any third party's use or the results of such use of any information, apparatus, product, or process disclosed, or represents that its use would not infringe privately owned rights. Reference herein to any specific commercial product, process, or service by trade name, trademark, manufacturer, or otherwise, does not necessarily constitute or imply its endorsement, recommendation, or favoring by the United States Government or any agency thereof or its contractors or subcontractors. The views and opinions of authors expressed herein do not necessarily state or reflect those of the United States Government or any agency thereof.

CONTENTS

	Page
SUMMARY.....	6
QUALITY ASSURANCE.....	7
1. SYSTEM FUNCTIONS AND DESIGN CRITERIA.....	8
1.1 SYSTEM FUNCTIONS.....	8
1.2 SYSTEM DESIGN CRITERIA.....	9
1.3 SUBSYSTEM DESIGN CRITERIA.....	19
1.4 CONFORMANCE VERIFICATION.....	19
2. DESIGN DESCRIPTION.....	20
2.1 SYSTEM DESIGN SUMMARY.....	20
2.2 DESIGN ASSUMPTIONS.....	21
2.3 DETAILED DESIGN DESCRIPTION.....	22
2.4 COMPONENT DESCRIPTION.....	25
2.5 CRITERIA COMPLIANCE.....	28
3. SYSTEM OPERATIONS.....	39
4. SYSTEM MAINTENANCE.....	40
APPENDIX A CRITERION BASIS STATEMENTS.....	41
APPENDIX B ARCHITECTURE AND CLASSIFICATION.....	63
APPENDIX C ACRONYMS, SYMBOLS, AND UNITS.....	64
APPENDIX D FUTURE REVISION RECOMMENDATIONS AND ISSUES.....	66
APPENDIX E REFERENCES.....	68

TABLES

	Page
1. HLW Canisters.....	10
2. DOE SNF Categories.....	10
3. Categorization for Criticality, Structural, and Thermal Analyses.....	11
4. Categorization for Total System Performance Assessment.....	11
5. DOE SNF Canisters.....	12
6. Emplacement Drift External Environment.....	17
7. Induced/Handling External Environment.....	18
8. 5-DHLW/DOE SNF Short Disposal Container Dimensions.....	22
9. 5-DHLW/DOE SNF Fuel Characteristics.....	25
10. 5-DHLW/DOE SNF Short Disposal Container Components.....	25
11. 5-DHLW/DOE SNF Short Lids.....	26
12. 5-DHLW/DOE SNF Short Disposal Container Trunnion Collar Sleeves.....	26
13. Variation of Stress from Internal Pressure with Temperature.....	35
14. Applicability of “1995 ASME Boiler and Pressure Vessel Code”.....	37
15. System Architecture and Quality Assurance Classification.....	63

FIGURES

	Page
1. 5-DHLW/DOE SNF Short Disposal Container Configuration.....	23
2. Closure Welds Configuration.....	24
3. Trunnion Collar Configuration.....	27

SUMMARY

The Defense High Level Waste Disposal Container System supports the confinement and isolation of waste within the Engineered Barrier System of the Monitored Geologic Repository (MGR). Disposal containers are loaded and sealed in the surface waste handling facilities, transferred to the underground through the accesses using a rail mounted transporter, and emplaced in emplacement drifts. The defense high level waste (HLW) disposal container provides long-term confinement of the commercial HLW and defense HLW (including immobilized plutonium waste forms [IPWF]) placed within disposable canisters, and withstands the loading, transfer, emplacement, and retrieval loads and environments. U.S. Department of Energy (DOE)-owned spent nuclear fuel (SNF) in disposable canisters may also be placed in a defense HLW disposal container along with commercial HLW waste forms, which is known as "co-disposal."

The Defense High Level Waste Disposal Container System provides containment of waste for a designated period of time, and limits radionuclide release. The disposal container/waste package maintains the waste in a designated configuration, withstands maximum handling and rockfall loads, limits the individual canister temperatures after emplacement, resists corrosion in the expected handling and repository environments, and provides containment of waste in the event of an accident.

Defense HLW disposal containers for HLW disposal will hold up to five HLW canisters. Defense HLW disposal containers for co-disposal will hold up to five HLW canisters arranged in a ring and one DOE SNF canister inserted in the center and/or one or more DOE SNF canisters displacing a HLW canister in the ring. Defense HLW disposal containers also will hold two Multi-Canister Overpacks (MCOs) and two HLW canisters in one disposal container. The disposal container will include outer and inner cylinders, outer and inner cylinder lids, and may include a canister guide. An exterior label will provide a means by which to identify the disposal container and its contents.

Different materials will be selected for the disposal container inner and outer cylinders. The two metal cylinders, in combination with the Emplacement Drift System, drip shield, and natural barrier, will support the design philosophy of defense-in-depth. The use of materials with different properties prevents a single mode failure from breaching the waste package. The inner cylinder and inner cylinder lids will be constructed of stainless steel and the outer cylinder and outer cylinder lids will be a barrier made of high-nickel alloy.

The defense HLW disposal container interfaces with the emplacement drift environment and the internal waste by transferring heat from the canisters to the external environment and by protecting the canisters and their contents from damage/degradation by the external environment. The disposal container also interfaces with the canisters by limiting access of moderator and oxidizing agents to the waste. A loaded and sealed disposal container (waste package) interfaces with the Emplacement Drift System's emplacement drift waste package supports upon which the waste packages are placed. The disposal container interfaces with the Canister Transfer System, Waste Emplacement/Retrieval System, Disposal Container Handling System, and Waste Package Remediation System during loading, handling, transfer, emplacement, and retrieval of the disposal container/waste package.

QUALITY ASSURANCE

The quality assurance (QA) program applies to the development of this document. The activity evaluation for work package number 11612125N4, included in "Technical Work Plan for: Waste Package Design Description for SR" (p. 36), has determined the development of this document is subject to "Quality Assurance Requirements and Description" requirements. Electronic management of data is also controlled in accordance with "Technical Work Plan for: Waste Package Design Description for SR." This document was developed in accordance with AP-3.11Q, "Technical Reports."

1. SYSTEM FUNCTIONS AND DESIGN CRITERIA

The functions and design criteria for the Defense High Level Waste Disposal Container System are identified in the following sections. Throughout this document the term “disposal container” is used to indicate the Defense High Level Waste Disposal Container System. The system architecture and classification are provided in Appendix B.

The term “disposal container” means the container cylinders and any integral structures (spacers, lifting features, absorbent materials, etc.). The term “waste package” means a disposal container that is loaded with a waste form, sealed by the designed methods, and is tested and accepted.

To address the term “breach” in a quantified manner, threshold limits for failure per American Society of Mechanical Engineers (ASME) code are to be used. Throughout this document when the term “breach” is referred to in a function or criterion, the following apply: During normal handling operations, breach has occurred, analytically, when Subsection NB 3200 limits of stress intensity for the stress categories are exceeded. (A later code edition acceptable to the U.S. Nuclear Regulatory Commission and the U.S. Department of Energy may be used in the final design.) For “Level D” (design basis event) conditions, breach has occurred, analytically, when 0.9 of the ultimate tensile strength is exceeded through the outer barrier thickness.

1.1 SYSTEM FUNCTIONS

- 1.1.1 The disposal container/waste package contains canistered HLW and canistered DOE SNF within its boundary until it is breached.
- 1.1.2 The waste package restricts the transport of radionuclides to the outside of the waste package boundary after it is breached.
- 1.1.3 The disposal container/waste package provides criticality control during loading and after it is loaded with waste.
- 1.1.4 The waste package accommodates the thermal loading strategy for the repository.
- 1.1.5 The disposal container/waste package provides identification of individual disposal containers and their contents.
- 1.1.6 The disposal container/waste package provides safety for personnel, equipment, and the environment.
- 1.1.7 The disposal container/waste package prevents adverse reactions involving the waste form.
- 1.1.8 The disposal container/waste package withstands loading, handling, sealing, transfer, emplacement, and retrieval loads.
- 1.1.9 The waste package withstands the emplacement drift environment for the period of interest.
- 1.1.10 The disposal container/waste package provides conditions needed to maintain the physical and chemical stability of the waste form.

- 1.1.11 The waste package minimizes mobilization of radionuclides.
- 1.1.12 The waste package allows heat transfer between the waste form canister and the environment external to the waste package.
- 1.1.13 The disposal container/waste package accommodates handling, sealing, loading, emplacement, and retrieval operations.
- 1.1.14 The disposal container/waste package outer surface facilitates decontamination.

1.2 **SYSTEM DESIGN CRITERIA**

This section presents the design criteria for the system. Each criterion in this section has a corresponding Criterion Basis Statement in Appendix A that describes the need for the criterion as well as a basis for the performance parameters imposed by the criterion. Each criterion in this section also contains bracketed traces indicating traceability, as applicable, to the functions (F) in Section 1.1, the "Monitored Geologic Repository Requirements Document" (MGR RD), and "Revised Interim Guidance Pending Issuance of New U.S. Nuclear Regulatory Commission (NRC) Regulations (Revision 01, July 22, 1999), for Yucca Mountain, Nevada." In anticipation of the interim guidance being promulgated as a Code of Federal Regulations, it will be referred to as "10 CFR 63" in this system description document. For the applicable version of the codes, standards, and regulatory documents imposed on the design of this system, refer to Appendix E.

1.2.1 **System Performance Criteria**

- 1.2.1.1 The disposal container shall accommodate the HLW canisters identified in Table 1. Table 1 also identifies nominal parameters (size, weight, and materials) that may be used in design (TBV-264). (TBV-455 is also placed on this criterion because that TBV is placed on the reference document, in accordance with "Deficiency Report VAMO-98-D-132.")

Table 1. HLW Canisters

Canister Producer	Nominal Outside Diameter	Nominal Overall Height	Individual Canister Weight	Canister Material
Hanford Site (Short)*	61 cm (24 in.) (TBV-264)	300 cm (118 in.) (TBV-264)	2,150 kg (4,740 lb) (TBV-264)	304L Stainless Steel (TBV-264)
Hanford Site (Long)*	61 cm (24 in.) (TBV-264)	457.2 cm (180 in.) (TBV-264)	4,200 kg (9,259 lb) (TBV-264)	304L Stainless Steel (TBV-264)
Idaho National Engineering and Environmental Laboratory	61 cm (24 in.) (TBV-264)	300 cm (118 in.) (TBV-264)	2,325 kg (5,126 lb) (TBV-264)	304L Stainless Steel (TBV-264)
Savannah River Site**	61 cm (24 in.)	300 cm (118 in.)	2,182 kg (4,810 lb)	304L Stainless Steel
West Valley Demonstration Project	61 cm (24 in.)	300 cm (118 in.)	2,152 kg (4,744 lb)	304L Stainless Steel

* There is no clear indication from Hanford on which canister will actually be produced.

** 17 MT of IPWF is included in Savannah River Site canisters.

Note: For definition of acronyms, symbols and units, see Appendix C.

[F 1.1.1][MGR RD 3.2.A]

1.2.1.2

The disposal container shall accommodate DOE SNF identified in Table 2. (TBV-327) Table 3 lists further groupings from Table 2 used in criticality, structural, and thermal analyses. Table 4 lists further groupings from Table 2 used in Total System Performance Assessment (TSPA). The DOE SNF will arrive at the MGR in disposable canisters of the sizes and weights identified in Table 5.

Table 2. DOE SNF Categories

DOE SNF Category	Compound (Cladding Material)
U-Metal (LEU) (TBV)	Uranium Metal (Zircaloy)
U-Metal (LEU) (TBV)	Uranium Metal (Aluminum)
U-Zr (HEU) (TBV)	Uranium Alloy (Zircaloy)
U-Mo (HEU) (TBV)	Uranium Alloy (Zircaloy)
U-Oxide (HEU) (TBV)	Uranium Oxide (Zircaloy)
U-Oxide (MEU) (TBV)	Uranium Oxide (Zircaloy)
U-Oxide (LEU) (TBV)	Uranium Oxide (Zircaloy)
U-Oxide (HEU) (TBV)	Uranium Oxide (Stainless Steel)
U-Oxide (MEU) (TBV)	Uranium Oxide (Stainless Steel)
U-Oxide (LEU) (TBV)	Uranium Oxide (Stainless Steel)
U-Oxide (HEU) (TBV)	Uranium Oxide (Failed or Declad)
U-Oxide (MEU) (TBV)	Uranium Oxide (Failed or Declad)
U-Oxide (LEU) (TBV)	Uranium Oxide (Failed or Declad)
U-Oxide (HEU) (TBV)	Uranium Oxide (Aluminum)
U-Oxide (MEU) (TBV)	Uranium Oxide (Aluminum)
U-Al or U-Alx (HEU) (TBV)	Uranium Alloy (Aluminum)
U-Al or U-Alx (MEU) (TBV)	Uranium Alloy (Aluminum)
U-Si (HEU, MEU) (TBV)	Uranium Alloy (Aluminum)
U/Th Carbide (HEU) (TBV)	Thorium/Uranium Carbide (Graphite)
U or U/Pu Carbide (MEU) (TBV)	Uranium or Plutonium/Uranium Carbide
MOX (HEU) (TBV)	Plutonium/Uranium Oxide (Zircaloy)
MOX (HEU) (TBV)	Plutonium/Uranium Oxide (Stainless Steel)
MOX (MEU & LEU) (TBV)	Plutonium/Uranium Oxide (Various materials)

Defense High Level Waste Disposal Container System Description Document

Table 2. DOE SNF Categories (Continued)

DOE SNF Category	Compound (Cladding Material)
U/Th Oxide (HEU) (TBV)	Thorium/Uranium Oxide (Zircaloy)
U/Th Oxide (HEU) (TBV)	Thorium/Uranium Oxide (Stainless Steel)
U-Zr-Hx (HEU) (TBV)	Uranium-Zirconium Hydride (Stainless Steel/Incoloy)
U-Zr-Hx (MEU) (TBV)	Uranium-Zirconium Hydride (Stainless Steel/Incoloy)
U-Zr-Hx (MEU) (TBV)	Uranium-Zirconium Hydride (Aluminum)
U-Zr-Hx (HEU) (TBV)	Uranium-Zirconium Hydride (Declad)
Misc. SNF (HEU, MEU & LEU) (TBV)	(Various)

Table 3. Categorization for Criticality, Structural, and Thermal Analyses

DOE SNF Category	Compound (Cladding Material)
N-Reactor SNF	Uranium Metal (Zircaloy)
MOX (HEU, MEU, LEU)	Plutonium/Uranium Oxide (Zircaloy, SS)
U-Al	Uranium as metal oxide nitride silicate mixed alloyed with aluminum
U-Zr & U-Mo (HEU)	Uranium Alloy (Zircaloy)
U Oxide (HEU)	Uranium Oxide (Aluminum, Zircaloy, SS, Failed, or Declad)
U Oxide (MEU)	Uranium Oxide (Aluminum, Zircaloy, SS, Failed, or Declad)
U-Zr-Hx SNF (HEU, MEU)	Uranium-Zirconium Hydride (SS/Incoloy, Aluminum, Declad)
Th/U Oxide (HEU)	Thorium/Uranium Oxide (SS, Zircaloy)
U-Si Fuels (MEU)	Uranium Alloy (Aluminum)
Th/Pu/U Carbide (HEU, MEU)	Uranium or Plutonium/Uranium Carbide (Non-graphite), Thorium/Uranium Carbide (Graphite)
U Oxide (LEU)	Uranium Oxide (Zircaloy, SS, Failed, or Declad)

Table 4. Categorization for Total System Performance Assessment

DOE SNF Category	Compound (Cladding Material)
U-Metal Fuels	Uranium Metal (Zircaloy, Aluminum)
U-Zr Fuels	Uranium Alloy (Zircaloy)
U-Mo Fuels	Uranium Alloy (Zircaloy)
U-Oxide Intact Fuels	Uranium Oxide (Zircaloy, SS)
U-Oxide Failed/Declad Fuels	Uranium Oxide (Failed/ Declad, Aluminum)
U-Al or U-Alx Fuels	Uranium Alloy (Aluminum)
U-Si Fuels	Uranium Alloy (Aluminum)
U/Th Carbide Hi-integrity	Thorium/Uranium Carbide (Graphite)
U/Th Carbide Low-integrity	Thorium/Uranium Carbide (Graphite)
U or U/Pu Carbide Non-Graphite	Uranium or Plutonium/Uranium Carbide (Non-graphite)
MOX Fuels	Plutonium/Uranium Oxide (Zircaloy, SS, Misc. Clad)
U/Th Oxide Fuels	Thorium/Uranium Oxide (Zircaloy, SS)
U-Zr-Hx Fuels	Uranium-Zirconium Hydride (SS/Incoloy, Aluminum, Declad)
Miscellaneous SNF	Misc./Unknown Fuels (Misc., Declad)

Table 5. DOE SNF Canisters

Canister Type	Nominal Diameter	Maximum Length	Maximum Weight *
NSNFP 18 in. x 10 ft	457 mm (18 in.)	3,000 mm (118.11 in.)	2,270 kg (5,005 lb)
NSNFP 18 in. x 15 ft	457 mm (18 in.)	4,570 mm (179.92 in.)	2,721 kg (6,000 lb)
NSNFP 24 in. x 10 ft	610 mm (24 in.)	3,000 mm (118.11 in.)	4,080 kg (8,996 lb)
NSNFP 24 in. x 15 ft	610 mm (24 in.)	4,570 mm (179.92 in.)	4,535 kg (10,000 lb)
MCO 25 in. x 14 ft	642.87 mm (25.31 in.)	4,230.75 mm (166.565 in.)	8,746.4 kg (19,242 lb)

* Canister plus contents

Note: For definition of acronyms, symbols and units, see Appendix C.

[F 1.1.1][MGR RD 3.2.A]

- 1.2.1.3** The disposal container/waste package shall be designed, in conjunction with the Emplacement Drift System and the natural barrier, such that the expected annual dose to the average member of the critical group shall not exceed 25 mrem total effective dose equivalent at any time during the first 10,000 years after permanent closure, as a result of radioactive materials released from the geologic repository.

[F 1.1.1, 1.1.9][MGR RD 3.1.C][10 CFR 63.113(b)]

- 1.2.1.4** The disposal container shall consist of two cylinders; an inner cylinder that is stainless steel (alloy 316 NG) with a nominal thickness of 5 cm, and an outer cylinder that is alloy 22 material with a nominal thickness of 2 cm.

[F 1.1.1, 1.1.2][MGR RD 3.1.C][10 CFR 63.113(a)]

- 1.2.1.5** Reserved

- 1.2.1.6** The waste package shall maintain the temperature of HLW glass below 400 degrees C (752 degrees F) under normal conditions, and below 460 degrees C (860 degrees F) (TBV-245) for short-term exposure to fire, as specified by Criterion 1.2.2.1.11.

[F 1.1.10, 1.1.11, 1.1.12][MGR RD 3.1.C]
 [10 CFR 63.111(a)(2), 63.111(b)(2), 63.112(e)(8), 63.113(b)]

- 1.2.1.7** The waste package, including any internal structures, shall be designed to include sufficient shielding to protect the waste package materials (in the as-emplaced condition) from radiation enhanced corrosion.

[F 1.1.1, 1.1.2]

- 1.2.1.8** The disposal container/waste package shall prevent the breach of the waste form canister during normal handling operations.

[F 1.1.10][MGR RD 3.1.C][10 CFR 63.111(a)(2)]

- 1.2.1.9** The disposal container/waste package shall be designed to support/allow retrieval up to 300 years after the start of emplacement operations.
- [F 1.1.8, 1.1.13][MGR RD 3.1.C, 3.2.H][10 CFR 63.111(e)(1)]
- 1.2.1.10** Combined concentrations of O₂, H₂, H₂O, CO₂, and CO within a waste package shall not exceed 0.25 percent of internal volume (TBV-094) prior to waste package breach.
- [F 1.1.7, 1.1.10, 1.1.11][MGR RD 3.1.C][10 CFR 63.111(e)(1), 63.113(b)]
- 1.2.1.11** The disposal container/waste package, excluding the labels, shall have an external surface finish Roughness Average of 250 μin (6.35 μm) or less.
- [F 1.1.14][MGR RD 3.1.C][10 CFR 63.112(e)(2)]
- 1.2.1.12** The disposal container/waste package shall have all external surfaces (surfaces exposed to the external environment after closing and sealing a disposal container) accessible for visual inspection and decontamination (e.g., no blind holes).
- [F 1.1.14][MGR RD 3.1.C][10 CFR 63.112(e)(2)]
- 1.2.1.13** The disposal container/waste package shall have a label (or other means of identification) with a unique waste package identifier.
- [F 1.1.5][MGR RD 3.1.B, 3.1.C, 3.3.K][10 CFR 63.112(e)(2), 63.78]
- 1.2.1.14** All labels (or other means of identification) applied to the waste package shall not impair the integrity of the waste package.
- [F 1.1.1, 1.1.5][MGR RD 3.1.C][10 CFR 63.113(b)]
- 1.2.1.15** All information contained on all labels (or other means of identification) applied to the disposal container shall be legible or read by remote means until permanent closure of the repository.
- [F 1.1.5][MGR RD 3.1.C, 3.1.D, 3.3.K][10 CFR 63.112(e)(2), 63.78]
- 1.2.1.16** Lifting features of the disposal container/waste package shall be designed for three times the maximum weight of the loaded and sealed disposal container without generating a combined shear stress or maximum tensile stress in excess of the corresponding minimum tensile yield strength of the materials of construction.
- [F 1.1.8, 1.1.13][MGR RD 3.1.C, 3.1.G][10 CFR 63.111(a)(2), 63.111(b)(2), 63.112(e)(2), 63.112(e)(8)]

- 1.2.1.17** Lifting features of the disposal container/waste package shall be designed for five times the weight of the loaded disposal container without exceeding the ultimate tensile strength of the materials.
- [F 1.1.8, 1.1.13][MGR RD 3.1.C, 3.1.G][10 CFR 63.111(a)(2), 63.111(b)(2), 63.112(e)(2), 63.112(e)(8)]
- 1.2.1.18** The waste package shall be designed to withstand transfer, emplacement, and retrieval operations without breaching.
- [F 1.1.8, 1.1.13][MGR RD 3.1.C][10 CFR 63.111(a)(2)]
- 1.2.1.19** The disposal container/waste package shall be constructed of non-combustible and heat resistant materials only.
- [F 1.1.7, 1.1.10][MGR RD 3.1.C][10 CFR 63.111(a)(2), 63.111(b)(2), 63.112(e)(8)]
- 1.2.1.20** Disposal container/waste package materials shall exclude the use of explosive or pyrophoric materials.
- [F 1.1.2, 1.1.11][MGR RD 3.1.C][10 CFR 63.111(a)(2), 63.111(b)(2), 63.112(e)(8)]
- 1.2.1.21** Disposal container/waste package materials shall exclude the use of free liquids.
- [F 1.1.7, 1.1.10]
- 1.2.1.22** Manufacturing residual tensile stresses shall be maintained below 10 percent of yield strength of the outer barrier material for a depth of (TBD-235) from the outer surface.
- [F 1.1.2, 1.1.6]
- 1.2.1.23** Static loads in the outer barrier shall not produce tensile stresses above 10 percent of yield strength of the outer barrier material at the interface with the emplacement pallet.
- [F 1.1.2, 1.1.6]
- 1.2.1.24** Tensile stresses in the outer barrier shall be maintained below yield strength of the outer barrier material during a seismic event.
- [F 1.1.2, 1.1.6]

1.2.2 Safety Criteria

1.2.2.1 Nuclear Safety Criteria

1.2.2.1.1 During the preclosure period, the waste package shall be designed to withstand (while in a horizontal orientation) a 6 MT (13,230 lb) (TBV-245) rock falling 3.3 m (10.8 ft) (TBV-245) onto the side of the waste package without breaching. (TBV-245)

[F 1.1.1, 1.1.2, 1.1.6][MGR RD 3.1.C, 3.1.G][10 CFR 63.111(a)(2), 63.111(b)(2), 63.112(e)(8)]

1.2.2.1.2 During the preclosure period, the disposal container/waste package shall be designed to withstand (while in a vertical orientation) a 2.3 MT (5,100 lb) (TBV-245) spherical object falling 2 m (6.6 ft) (TBV-245) onto the end of the disposal container without breaching. (TBV-245)

[F 1.1.1, 1.1.2, 1.1.6][MGR RD 3.1.C, 3.1.G][10 CFR 63.111(a)(2), 63.111(b)(2), 63.112(e)(8)]

1.2.2.1.3 During the preclosure period, the disposal container/waste package, shall be designed to withstand (while in a vertical orientation) a drop from a height of 2 m (6.6 ft) (TBV-245) onto a flat, unyielding surface without breaching. (TBV-245)

[F 1.1.1, 1.1.2, 1.1.6][MGR RD 3.1.C, 3.1.G][10 CFR 63.111(a)(2), 63.111(b)(2), 63.112(e)(8)]

1.2.2.1.4 During the preclosure period, the disposal container/waste package, shall be designed to withstand (while in a horizontal orientation) a drop from a height of 2.4 m (7.9 ft) (TBV-245) onto a flat, unyielding surface without breaching. (TBV-245)

[F 1.1.1, 1.1.2, 1.1.6][MGR RD 3.1.C, 3.1.G][10 CFR 63.111(a)(2), 63.111(b)(2), 63.112(e)(8)]

1.2.2.1.5 During the preclosure period, the waste package shall be designed to withstand (while in a horizontal orientation) the stress resulting from a drop of the waste package with the emplacement pallet from a height of (TBD-235) onto an essentially unyielding surface without breaching by puncture. (TBV-245)

[F 1.1.1, 1.1.2, 1.1.6][MGR RD 3.1.C, 3.1.G][10 CFR 63.111(a)(2), 63.111(b)(2), 63.112(e)(8)]

1.2.2.1.6 During the preclosure period, the waste package shall be designed to withstand a tip over from a vertical position with slap down onto a flat, unyielding surface without breaching. (TBV-245)

[F 1.1.1, 1.1.2, 1.1.6][MGR RD 3.1.C, 3.1.G][10 CFR 63.111(a)(2), 63.111(b)(2), 63.112(e)(8)]

1.2.2.1.7 The waste package shall be designed to withstand a Frequency Category 2 Design Basis Earthquake during the preclosure period (TBV-1246). Both vibratory ground motion and fault displacement of the Frequency Category 2 Design Basis Earthquakes must be considered, taking credit as appropriate for interfacing systems that alter or mitigate the effect of the design basis earthquake on the waste package. (TBV-245)

[F 1.1.1, 1.1.6, 1.1.9][MGR RD 3.1.C, 3.1.G][10 CFR 63.111(a)(2), 63.111(b)(2), 63.112(e)(8)]

1.2.2.1.8 During the preclosure period, the waste package shall be designed to withstand the impact of a 0.5 kg (1.1 lb) (TBV-245) missile (modeled as a 1 cm diameter, 5 cm long valve stem) travelling at 5.7 m per second (18.7 ft/sec) (TBV-245) without breaching. (TBV-245)

[F 1.1.1, 1.1.2, 1.1.6][MGR RD 3.1.C, 3.1.G][10 CFR 63.111(a)(2), 63.111(b)(2), 63.112(e)(8)]

1.2.2.1.9 During the preclosure period, the waste package shall be designed to withstand, without breaching, the maximum impact resulting from a transporter runaway, derailment, and impact at a speed of 63 km/hr (39 mi/hr) (TBV-245), taking credit, as appropriate, for interfacing systems that prevent or mitigate the impact on the waste package. (TBV-245)

[F 1.1.1, 1.1.2, 1.1.6][MGR RD 3.1.C, 3.1.G][10 CFR 63.111(a)(2), 63.111(b)(2), 63.112(e)(8)]

1.2.2.1.10 During the preclosure period, the waste package shall be designed to withstand a maximum internal pressure of (TBD-235) without breaching. (TBV-245)

[F 1.1.1, 1.1.2, 1.1.6][MGR RD 3.1.C, 3.1.G][10 CFR 63.111(a)(2), 63.111(b)(2), 63.112(e)(8)]

1.2.2.1.11 The waste package/disposal container shall be designed to withstand the hypothetical fire criteria defined in 10 CFR 71 ("Packaging and Transportation of Radioactive Materials"), Section 73(c)(4). (TBV-245)

[F 1.1.1, 1.1.2, 1.1.6][MGR RD 3.1.C, 3.1.G][10 CFR 63.111(a)(2), 63.111(b)(2), 63.112(e)(8)]

1.2.2.1.12 During the preclosure period, the disposal container/waste package shall be designed such that the effective multiplication factor (k_{eff}) is less than or equal to 0.95 under assumed accident conditions considering allowance for the bias in the method of calculation and the uncertainty in the experiments used to validate the method of calculation. (TBV-245)

[F 1.1.3][MGR RD 3.1.C, 3.1.G][10 CFR 63.111(a)(2), 63.111(b)(2), 63.112(e)(6), 63.112(e)(8)]

1.2.2.1.13 During the postclosure period the waste package shall be designed such that the total frequency of criticality occurrence is less than 1 in 10,000 years for all waste packages. (TBV-096)

[F 1.1.3][MGR RD 3.1.C][10 CFR 63.113(b)]

1.2.2.1.14 During the postclosure period, any increase in radionuclide inventory due to a single criticality event from fissionable material emplaced in the waste package shall be less than 10 percent of the total radionuclide inventory available for release and transport for all waste packages to the accessible environment.

[F 1.1.3][MGR RD 3.1.C][10 CFR 63.113(b)]

1.2.2.2 Non-nuclear Safety Criteria

Non-nuclear safety criteria for this system will be identified in a later revision, as necessary.

1.2.3 System Environment Criteria

1.2.3.1 The waste package shall meet all performance requirements during and after exposure to the emplacement drift external environments identified in Table 6 (TBV-4743) (TBD-234) and the induced/handling environments identified in Table 7 (TBD-276).

Table 6. Emplacement Drift External Environment

Environment	Range	Duration/Frequency of Occurrence
Microbe Influx	0-10 ¹⁴ microbes/yr/m of drift (TBV-4743)	10,000 yr
pH	7 - 11	10,000 yr
Colloid Concentration	8x10 ⁻⁶ - 6x10 ⁻⁵ mg/ml (TBV-4743)	10,000 yr
Temperature	TBD-234	TBD-234
Humidity	0 - 95%	10,000 yr
Radiation	TBD-234	TBD-234
Water Seepage	4.6 mm/yr 12.2 mm/yr 17.8 mm/yr	To year 2,600 From year 2,600 to year 3,000 From year 3,000 to year 12,000
TBD-234	TBD-234	TBD-234

Table 7. Induced/Handling External Environment

Environment	Range	Duration/Frequency of Occurrence
Vibration	TBD-276	TBD-276
Shock	TBD-276	TBD-276
Acceleration	TBD-276	TBD-276
TBD-276	TBD-276	TBD-276

Note: For definition of acronyms, symbols and units, see Appendix C.

[F 1.1.9][MGR RD 3.1.C, 3.4.2.C][10 CFR 63.113(b)]

1.2.4 System Interfacing Criteria

1.2.4.1 Waste package design shall reduce the dose rate at all external surfaces of a waste package to 1,450 (TBV-248) rem/hr or less. This criterion identifies a disposal container interface with the Disposal Container Handling System, the Waste Emplacement/Retrieval System, and the Performance Confirmation Emplacement Drift Monitoring System.

[F 1.1.6, 1.1.13][MGR RD 3.1.B, 3.1.G]

1.2.4.2 The waste package shall be designed to have a maximum thermal output of 11.8 kW.

[F 1.1.4]

1.2.4.3 The system shall be designed to accommodate 640 MTU of commercial HLW, 4,027 MTU of defense HLW, and, in combination with DOE SNF disposal containers, not more than 2,437 MTU of DOE SNF. This criterion identifies the primary disposal container interface with the DOE Spent Nuclear Fuel Disposal Container System.

[F 1.1.1][MGR RD 3.1.A, 3.2.A, 3.2.B]

1.2.4.4 The disposal container shall be designed to be loaded and sealed in a vertical orientation. This criterion identifies the primary disposal container interface with the Canister Transfer System and the Disposal Container Handling System.

[F 1.1.13]

1.2.4.5 The disposal container/waste package shall be designed to be handled in both horizontal and vertical orientations. This criterion identifies the primary disposal container interface with the Disposal Container Handling System, and Waste Emplacement/Retrieval System.

[F 1.1.13]

1.2.4.6 The disposal container/waste package shall be designed to support required welding times. This criterion identifies a primary disposal container interface with the Disposal Container Handling System.

[F 1.1.13]

1.2.5 Operational Criteria

Operational criteria for this system will be identified in a later revision, if necessary.

1.2.6 Codes and Standards Criteria

1.2.6.1 The disposal container shall be designed in accordance with applicable sections of "1995 ASME Boiler and Pressure Vessel Code" (Section III, Division 1, Subsection NG-1995).

[MGR RD 3.3.A]

1.2.6.2 The disposal container shall be designed in accordance with applicable sections of "1995 ASME Boiler and Pressure Vessel Code" (Section III, Division 1, Subsection NB-1995).

[MGR RD 3.3.A]

1.2.6.3 The disposal container shall be designed in accordance with applicable sections of "Nuclear Criticality Control of Special Actinide Elements" (ANSI/ANS-8.15-1981).

[MGR RD 3.3.A]

1.2.6.4 The disposal container shall be designed in accordance with applicable sections of "Nuclear Criticality Safety in Operations with Fissionable Materials Outside Reactors" (ANSI/ANS-8.1-1998).

[MGR RD 3.3.A]

1.2.6.5 The disposal container shall be designed in accordance with applicable sections of "Criteria for Nuclear Criticality Safety Controls in Operations with Shielding and Confinement" (ANSI/ANS-8.10-1983).

[MGR RD 3.3.A]

1.2.6.6 The disposal container shall be designed in accordance with applicable sections of "Criticality Safety Criteria for the Handling, Storage, and Transportation of LWR Fuel Outside Reactors" (ANSI/ANS-8.17-1984).

[MGR RD 3.3.A]

1.3 SUBSYSTEM DESIGN CRITERIA

Subsystem design criteria for this system will be identified in a later revision, if necessary.

1.4 CONFORMANCE VERIFICATION

This section will be provided in a future revision.

2. DESIGN DESCRIPTION

Section 2 of this SDD summarizes information that is contained in other references. By assembling system specific information contained elsewhere (i.e., analyses, technical reports, etc.), Section 2 provides insight into the current state of the design of this system. However, due to the nature of design development, the information contained in this section will continue to change as the design matures.

2.1 SYSTEM DESIGN SUMMARY

The DHLW disposal containers are designed to accept canistered defense and canistered commercial HLW. Canisters of DOE-managed spent nuclear fuel may also be placed in a DHLW disposal container along with the HLW forms. The designs developed for the DHLW disposal container system consist of a 5-DHLW/DOE SNF short disposal container design, a 5-DHLW/DOE SNF long disposal container design, and a 2-MCO/2-DHLW SNF disposal container design (reference "Design Analysis for the Defense High-Level Waste Disposal Container," Section 6.1). This section describes only the design of the 5-DHLW/DOE SNF short disposal container (see note below).

The 5-DHLW/DOE SNF short disposal container consists of two right-circular cylinders, hereafter called shells. It is comprised of two shells, an inner shell of stainless steel that provides structural support and an outer shell of high-nickel alloy that provides a corrosion-resistant barrier. The inner structural shell is inserted inside the outer corrosion-resistant shell. There are two lower lids that are welded to the shells at the time of fabrication. There are three upper lids that are welded in place after the disposal containers are loaded with the appropriate waste forms (reference "Design Analysis for the Defense High-Level Waste Disposal Container," Section 6).

NOTE: For Site Recommendation, a set of the detailed designs has been explicitly evaluated to ensure design criteria are met. Through a sensitivity analysis, it was decided which disposal container design best represents the array of design configurations and waste forms. The analysis also considered which of the design criteria would be satisfied by those representative designs. The analysis resulted in the selection of four disposal container designs (reference "Waste Package Design Sensitivity Report," Section 5) as adequate to jointly demonstrate compliance with design criteria for Site Recommendation:

- 21-PWR Absorber Plate
- 44-BWR
- 5-defense high-level waste (DHLW)/U.S Department of Energy (DOE) SNF short
- naval SNF long.

For criteria that apply to multiple designs, a decision may be made to evaluate just one of the four designs to demonstrate the methodology (reference "Waste Package Design Sensitivity Report," Section 6). The design and design criteria selected for Site Recommendation are provided in Section 2.5. More complete design information will be provided for all waste package designs as a part of the licensing process.

2.2 DESIGN ASSUMPTIONS

2.2.1 Structural

The waste package internal pressure as a result of the fuel rod rupture design event in a 21-PWR waste package was assumed to evaluate the gas pressure at constant density for several temperature values in the 5-DHLW/DOE SNF short disposal container design (reference "Design Analysis for the Defense High-Level Waste Disposal Container," Section 5.1). It should be noted that the DHLW/DOE SNF waste packages contain canistered waste forms and therefore, there are no bare fuel rods inside these waste packages under normal conditions. This assumption has been used to obtain the results shown in Section 2.5.2.10.

2.2.2 Thermal

The calculation "Thermal Evaluation of the TRIGA Codisposal Waste Package" considered the Viability Assessment (VA) design for the disposal container. It is assumed that its results can be used to demonstrate waste package compliance with Criterion 1.2.1.6.

Also, the boundary temperature history for a DHLW/Training Research Isotopes-General Atomics (TRIGA) SNF codisposal waste package was assumed to be bounded by the boundary temperature history for the average-heat 44-BWR waste package (reference "Thermal Evaluation of the TRIGA Codisposal Waste Package," Assumption 3.26).

2.2.3 Shielding

The gamma and neutron source terms of the DWPF Design-Basis Glass at one day after pouring were assumed for the Savannah River Site (SRS) DHLW glass canisters (reference "Dose Rate Calculation for the DHLW/DOE SNF Codisposal Waste Package," p. 12). This assumption has been used to evaluate an upper limit for the waste-package surface dose rates, which is shown in Section 2.5.4.1, below.

2.2.4 Criticality

The calculation "TRIGA Fuel Phase I and II Criticality Calculation" considered the VA design for the disposal container. It is assumed that its results do not change with the disposal container design for Site Recommendation. The fuel

was assumed to be fresh (non-irradiated), and no credit was taken for the fuel burnup or for the erbium burnable absorber (reference "TRIGA Fuel Phase I and II Criticality Calculation," Assumptions 3.2 and 3.3).

2.3 DETAILED DESIGN DESCRIPTION

The 5-DHLW/DOE SNF short disposal container accommodates 5 DHLW glass canisters and one DOE SNF canister (reference "Design Analysis for the Defense High-Level Waste Disposal Container," Section 6.1). The 5-DHLW/DOE SNF short disposal container can also accommodate 5 canisters containing immobilized plutonium within the DHLW glass canister.

The 5-DHLW/DOE SNF short disposal containers are essentially right-circular cylinders, hereafter called shells. The inner shell is a 50-mm thick cylinder of stainless steel SA-240 S31600, which provides structural support. The outer shell is comprised of 25 mm of low-carbon nickel-molybdenum-chromium alloy SB-575 N06022 (Alloy 22), and serves as a corrosion resistant material. There are two lower lids that are welded to the shells at the time of fabrication. There are three upper lids that are welded in place after the waste packages are loaded with the appropriate waste forms. Figure 1 is a view of the 5-DHLW/DOE SNF short disposal container configuration. Figure 2 is a view of the upper lids closure welds. The dimensions for the 5-DHLW/DOE SNF short disposal container are provided in Table 8.

Table 8. 5-DHLW/DOE SNF Short Disposal Container Dimensions

Barrier Outer Diameter	2.030 m
Actual Outer Diameter	2.110 m
Outer Length	3.590 m
Empty Mass	23,360 kg
Loaded Mass	38,130 kg

(Reference: "Design Analysis for the Defense High-Level Waste Disposal Container," Attachment III)

The waste package cavity allows a uniform emplacement of five DHLW glass canisters surrounding an 18 in. diameter DOE standardized SNF canister. The DHLW and DOE SNF characteristics are provided in Table 9.

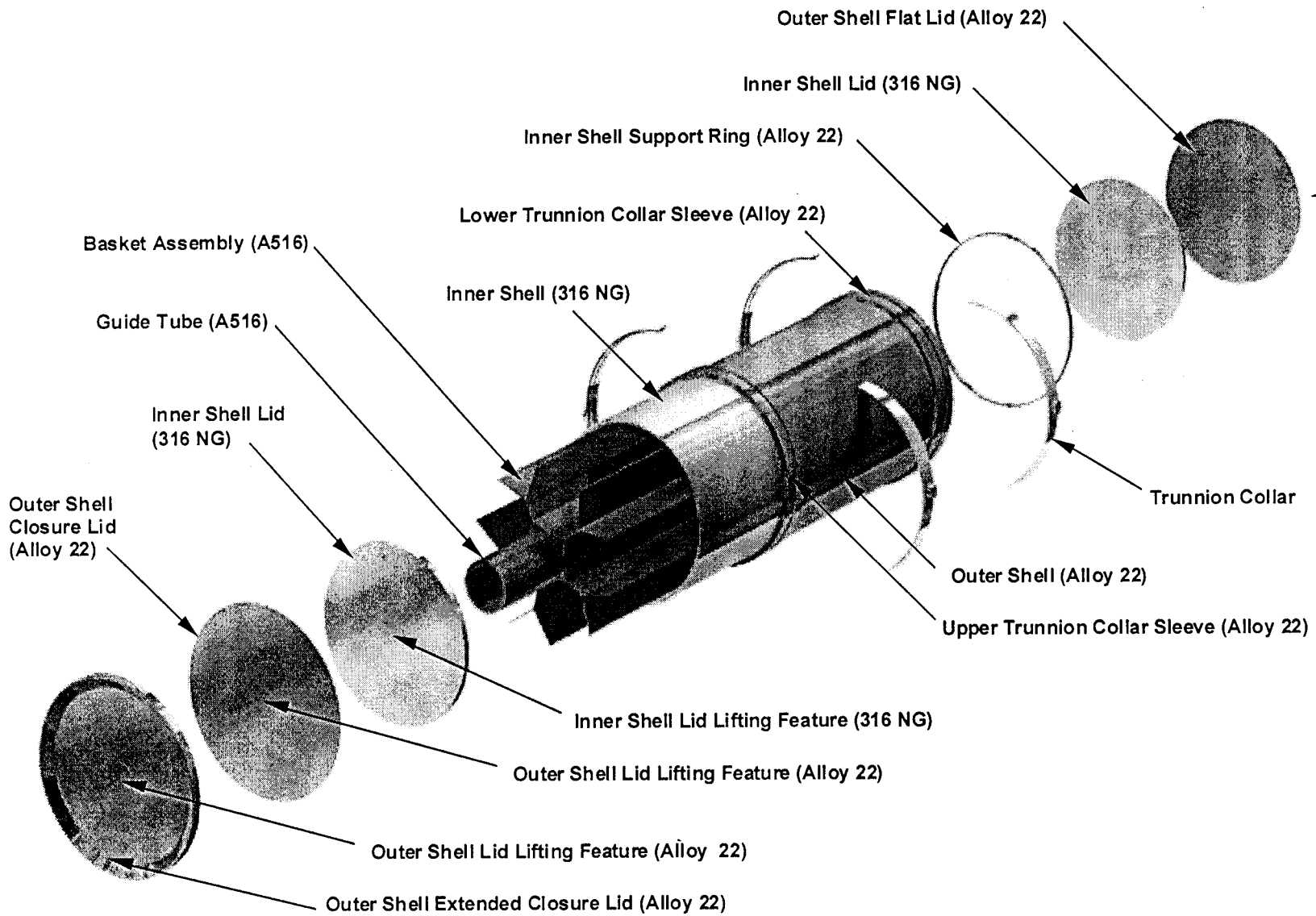

Figure 1. 5-DHLW/DOE SNF Short Disposal Container Configuration

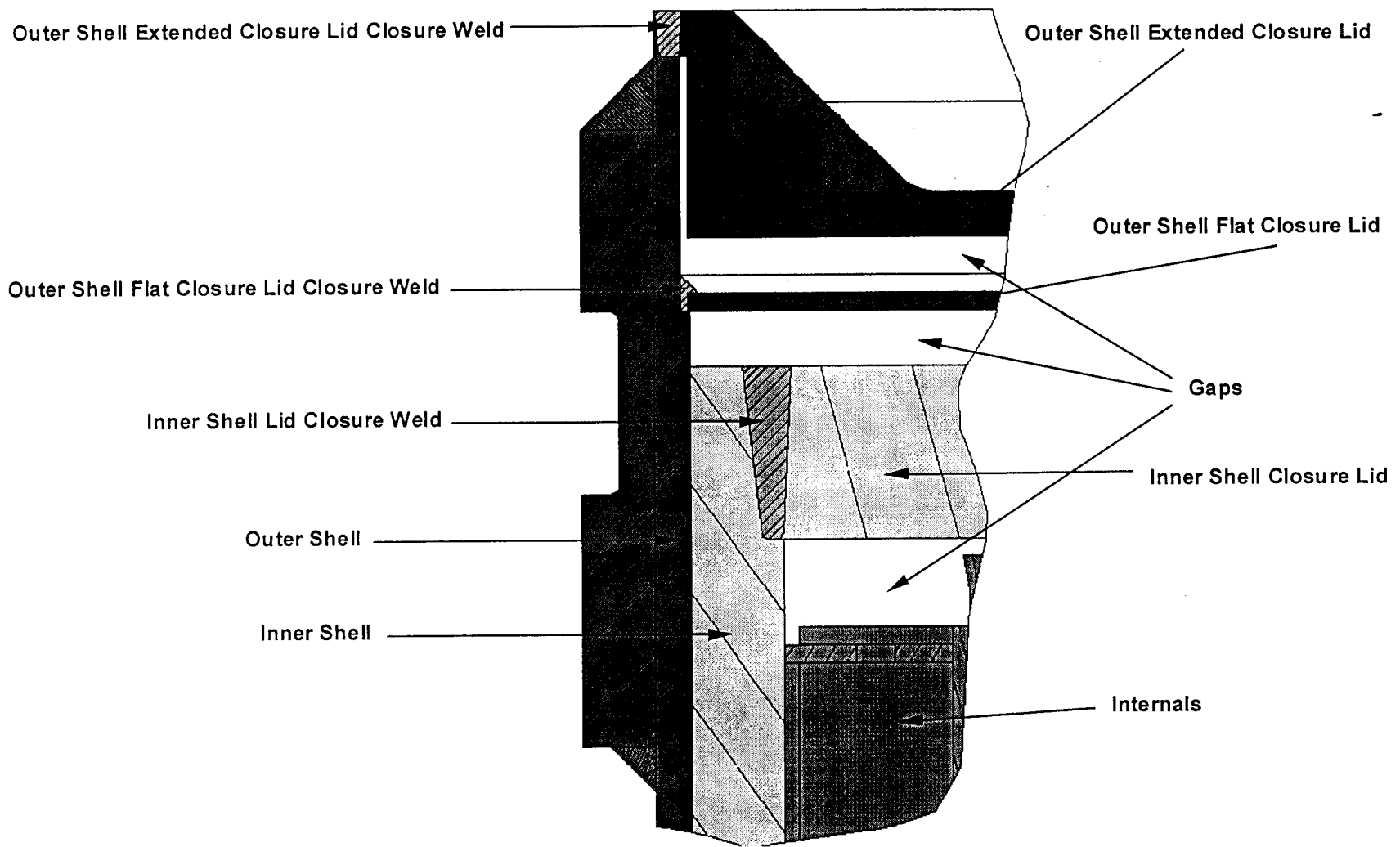

Figure 2. Closure Welds Configuration

Table 9. 5-DHLW/DOE SNF Fuel Characteristics

Characteristic	DHLW (Short)	DOE SNF 18" (Short)
Canister Nominal Outer Diameter (Note 1)	610 mm	457 mm
Canister Maximum External Length	3,000 mm (Note 1)	3,000 mm (Note 2)
Canister Maximum Mass (Notes 1 and 2)	2,182 kg (Note 1)	2,270 kg (Note 2)
Maximum Canister Heat Generation Rate at the year of shipment (Note 1)	752 W (Note 1)	Not Available
Number of Canisters	7,647 (Notes 4 and 5)	1,570 (Notes 3 and 6)

- Note 1: Reference: "Design Analysis for the Defense High-Level Waste Disposal Container," pp. 13 and 14
- Note 2: Reference: "Preliminary Design Specification for Department of Energy Standardized Spent Nuclear Fuel Canisters," Table 3.1 and p. 6
- Note 3: Reference: "DOE Spent Nuclear Fuel Information in Support of TSPA-SR," p. 45
- Note 4: Reference: "Waste Package Design Sensitivity Report," Table A-2
- Note 5: This number includes the 635 canisters containing immobilized plutonium
- Note 6: The remaining 40 DOE SNF 18" will be placed in 5-DHLW/DOE SNF-long waste packages

2.4 COMPONENT DESCRIPTION

2.4.1 Internal Support Structure

A 31.75-mm thick carbon steel support tube, with a nominal outer diameter of 565 mm, separates the DOE SNF canister from the DHLW glass canisters and reduces the deformation of the DOE SNF canister components during design basis events. The support tube is connected to the inside shell of the waste package by a web-like structure of carbon steel basket plates to support five DHLW glass canisters. The support tube and the plates are 3,030-mm long (reference "Design Analysis for the Defense High-Level Waste Disposal Container," Attachment III). Materials of construction and dimensions are provided in Table 10 for the internal support structure.

Table 10. 5-DHLW/DOE SNF Short Disposal Container Components

Component Name	Material	Thickness	Length	Quantity
Divider Plate	SA-516 K02700	12.7 mm	3,030 mm	5
Inner Bracket	SA-516 K02700	25.4 mm	3,030 mm	5
Outer Bracket	SA-516 K02700	12.7 mm	3,030 mm	5
Support Tube	SA-516 K02700	31.75 mm	3,030 mm	1

(Reference: "Design Analysis for the Defense High-Level Waste Disposal Container," Attachment III)

2.4.2 Lids

The disposal container contains two lower lids that are welded to the shells at the time of fabrication. This allows the disposal container to be loaded and sealed in a vertical orientation. The three upper lids will be welded in place after loading

the disposal container with the appropriate waste forms. Lid materials and dimensions are provided in the Table 11.

Table 11. 5-DHLW/DOE SNF Short Lids

Lid	Material	Thickness
Extended Outer Shell Lid Base (Top)	SB-575 N06022	25 mm
Outer Shell Flat Closure Lid (Top)	SB-575 N06022	10 mm
Inner Shell Lid (Top)	SA-240 S31600	80 mm
Inner Shell Lid (Bottom)	SA-240 S31600	80 mm
Outer Shell Flat Bottom Lid (Bottom)	SB-575 N06022	25 mm

(Reference: "Design Analysis for the Defense High-Level Waste Disposal Container," Attachment III)

2.4.3 Lifting Features

The disposal containers are designed to accept trunnion rings (see Figure 3). The use of trunnion rings permits attachments of fixtures that may be used for both vertical and horizontal handling of the waste package, as well as attitudes between vertical and horizontal. The trunnion rings are removed after the waste package is placed on the emplacement pallet; therefore, the use of trunnion rings does not create a site for crevice corrosion cracking. Further, trunnion rings are attached to a corresponding built-up area on the waste package and will not induce stresses that might exacerbate corrosion of the outer barrier. Materials of construction and dimensions for the trunnions are provided in Table 12.

Table 12. 5-DHLW/DOE SNF Short Disposal Container Trunnion Collar Sleeves

Component Name	Material	Thickness	Length	Quantity
Upper Trunnion Collar Sleeve	SB-575 N06022	40 mm	340 mm	1
Lower Trunnion Collar Sleeve	SB-575 N06022	40 mm	345 mm	1

(Reference: "Design Analysis for the Defense High-Level Waste Disposal Container," Attachment III)

2.4.4 Fill Gas

Fill gas is used to provide an inert atmosphere within the waste package and to facilitate heat conduction from the waste form to the containment barriers. The fill gas can be a significant conductor of heat from the fuel to the basket, therefore thermal performance was one of the most important criteria in choosing a gas. The fill gas should not degrade other components of the waste package, so compatibility with other materials was another important criterion. Based on a review of data on thermal conductivity, and the fact that helium is chemically inert, it was chosen over other candidate gases (reference "Waste Package Neutron Absorber, Thermal Shunt, and Fill Gas Selection Report," Sections 3.3.1 through 3.3.3). The waste package will be filled with helium to approximately one atmosphere of pressure.

Waste Package Configuration Before Trunnion Collar Emplacement

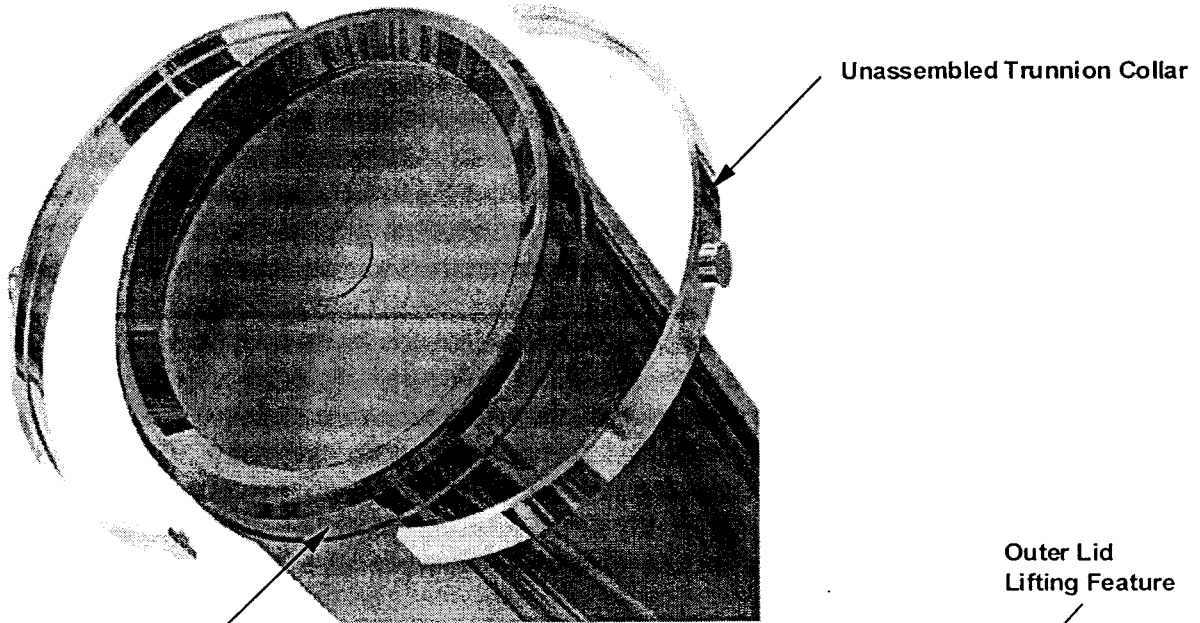

Trunnion Collar Sleeve

Unassembled Trunnion Collar

Outer Lid
Lifting Feature

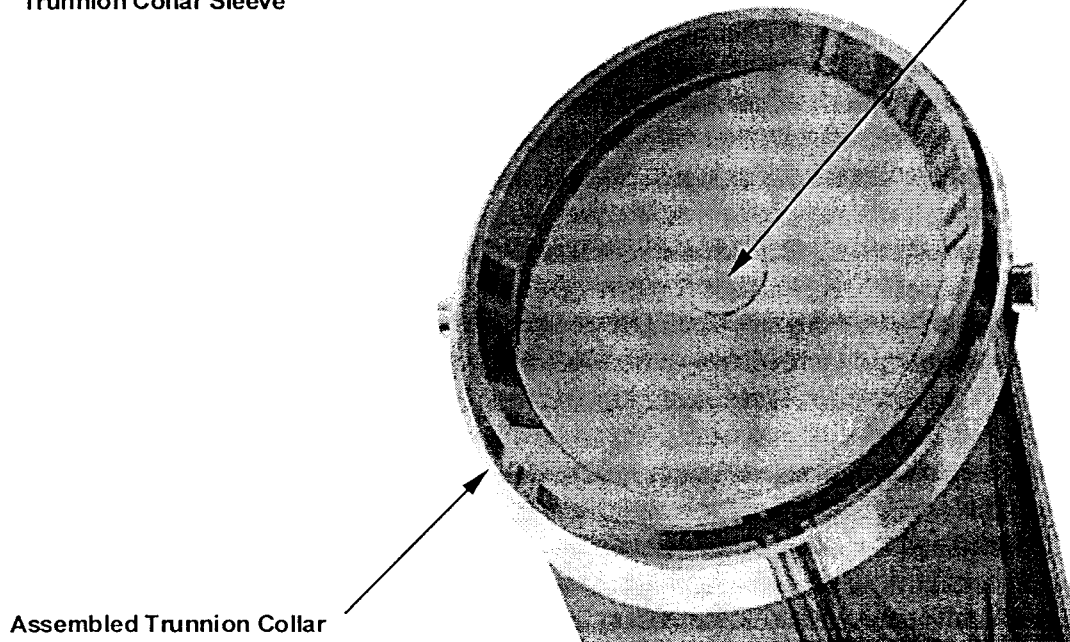

Assembled Trunnion Collar

Waste Package Configuration After Trunnion Collar Emplacement

Figure 3. Trunnion Collar Configuration

2.5 CRITERIA COMPLIANCE

This section contains the demonstration that the Site Recommendation waste package design satisfies the selected SDD criteria. It is limited to SDD criteria that were selected for the 5-DHLW/DOE SNF short design by the “Waste Package Design Sensitivity Report” (Section 5). The remaining SDD criteria are either demonstrated by the other waste package designs and therefore addressed in the Naval SDD or the uncanistered fuel (UCF) SDD or will not be demonstrated until License Application (reference “Waste Package Design Sensitivity Report,” Table 2).

2.5.1 System Performance Criteria

2.5.1.1 Accommodation of HLW Canisters (Criterion 1.2.1.1)

It may be demonstrated by inspection of the sketches contained in “Design Analysis for the Defense High-Level Waste Disposal Container” (Section 4.1.2 and Attachment III) that short canisters of HLW can be accommodated in the 5-DHLW/DOE SNF Short (reference “Design Analysis for the Defense High-Level Waste Disposal Container,” Section 6.3).

2.5.1.2 Accommodation of DOE SNF Canisters (Criterion 1.2.1.2)

It may be demonstrated by inspection of the sketches contained in “Design Analysis for the Defense High-Level Waste Disposal Container” (Section 4.1.3 and Attachment I) that short canisters of DOE SNF can be accommodated in the 5-DHLW/DOE SNF Short (reference “Design Analysis for the Defense High-Level Waste Disposal Container,” Section 6.3).

2.5.1.3 Limiting Total Effective Dose (Criterion 1.2.1.3)

Satisfaction of this criterion will be demonstrated in a report to be prepared by the Performance Assessment Organization (reference “Design Analysis for the Defense High-Level Waste Disposal Container,” Table 15).

2.5.1.4 Thickness and Composition of Cylinders (Criterion 1.2.1.4)

Due to the requirement for preclosure rock fall, the design engineers have specified an outer cylinder thickness of 25 mm. The 25-mm thickness exceeds the 20-mm requirement. The material callout on the sketches in “Design Analysis for the Defense High-Level Waste Disposal Container” (Attachment III) specify the use of SB-575 N06022, which is the ASME equivalent of Alloy 22.

Criterion 1.2.1.4 requires the inner cylinder be constructed of approximately 50-mm thick 316L stainless steel. The material callout on the sketches in “Design Analysis for the Defense High-Level Waste Disposal Container” (Attachment III) specifies the use of SA-240 S31600, which is equivalent to ASTM SS-316NG

(nuclear grade) (reference “Design Analysis for the Defense High-Level Waste Disposal Container,” Section 6.3).

2.5.1.5 Reserved

2.5.1.6 DHLW Canister Temperature (Criterion 1.2.1.6)

Evaluations to calculate peak temperatures at the center of the SRS DHLW glass canister and the DOE SNF canister were performed for a period of 50 years after waste package emplacement. A maximum peak value of 214.5 degrees C occurs in the glass at 20 years after emplacement under normal conditions, which is below the 400 degrees C threshold (reference “Design Analysis for the Defense High-Level Waste Disposal Container,” Section 6.3).

Compliance with the 460 degrees C limit for short-term exposure to fire will not be demonstrated for Site Recommendation.

2.5.1.7 Reserved

2.5.1.8 Prevent Breach of the Waste Form Canister (Criterion 1.2.1.8)

This design criterion will not be addressed for Site Recommendation (reference “Design Analysis for the Defense High-Level Waste Disposal Container,” Table 15).

2.5.1.9 Retrieval Contingency Period (Criterion 1.2.1.9)

The waste package must be designed to allow retrieval up to 300 years after emplacement. The naval long SNF waste package is the heaviest waste package for the purposes of retrieval. Therefore, the naval SNF disposal container design addresses this criterion. Compliance with this criterion is shown in “Design Analysis for the Naval SNF Waste Package,” Section 6.3.1.5.

2.5.1.10 Concentration of Chemically Reactive Gases (Criterion 1.2.1.10)

This design criterion will not be addressed for Site Recommendation (reference “Design Analysis for the Defense High-Level Waste Disposal Container,” Table 15).

2.5.1.11 External Surface Finish (Criterion 1.2.1.11)

This design criterion will not be addressed for Site Recommendation (reference “Design Analysis for the Defense High-Level Waste Disposal Container,” Table 15).

2.5.1.12 Inspectability of Waste Packages (Criterion 1.2.1.12)

It may be demonstrated by inspection of the sketches in “Design Analysis for the Defense High-Level Waste Disposal Container” (Attachment III) that all surfaces are accessible for visual inspection and decontamination (reference “Design Analysis for the Defense High-Level Waste Disposal Container,” Section 6.3).

2.5.1.13 Unique Label/Identification (Criterion 1.2.1.13)

This design criterion will not be addressed for Site Recommendation (reference “Design Analysis for the Defense High-Level Waste Disposal Container,” Table 15).

2.5.1.14 Label Does Not Impair Integrity (Criterion 1.2.1.14)

This design criterion will not be addressed for Site Recommendation (reference “Design Analysis for the Defense High-Level Waste Disposal Container,” Table 15).

2.5.1.15 Legible Labels (Criterion 1.2.1.15)

This design criterion will not be addressed for Site Recommendation (reference “Design Analysis for the Defense High-Level Waste Disposal Container,” Table 15).

2.5.1.16 Capacity of Lifting Devices – Tensile Yield Strength (Criterion 1.2.1.16)

A maximum expected stress of 9.1 MPa is generated in the upper trunnion collar sleeve during waste package horizontal and vertical normal lifting operations. Criterion 1.2.1.16 requires waste package lifting features that allow three times the maximum weight of the loaded and sealed disposal container without generating a combined shear stress or maximum tensile stress in excess of the corresponding minimum tensile yield strength of the materials of construction (Alloy 22).

Considering that the yield strength of the material is not exceeded, i.e., deformation remains in the elastic region of the stress-strain curve, a maximum stress of 27.3 MPa would be generated in the upper trunnion collar sleeve by increasing the loaded waste package weight three times. This value is well below the tensile yield strength of Alloy 22 (310 MPa). It should be noted that the maximum expected stress in the upper trunnion collar is about 30 times lower than the tensile yield strength of Alloy 22 (310 MPa), which allows larger stress design safety factors.

The large margin of safety indicates that the waste package lifting features may withstand dynamic loads, reducing the probability of the occurrence of a design-basis event. This demonstrates the design compliance with Criterion 1.2.1.16

(reference “Design Analysis for the Defense High-Level Waste Disposal Container,” Section 6.3).

2.5.1.17 Capacity of Lifting Devices – Ultimate Tensile Strength (Criterion 1.2.1.17)

A maximum expected stress of 9.1 MPa is generated in the upper trunnion collar sleeve during horizontal and vertical lifting of the waste package. Criterion 1.2.1.17 requires waste package lifting features that allow five times the maximum weight of the loaded and sealed disposal container without exceeding the ultimate tensile strength of the materials of construction (Alloy 22).

Considering that the yield strength of the material is not exceeded, i.e., deformation remains in the elastic region of the stress-strain curve, a maximum stress of 45.5 MPa would be generated in the upper trunnion collar sleeve by increasing the loaded waste package weight five times. This value is well below the ultimate tensile strength of Alloy 22 (690 MPa). It should be noted that the maximum expected stress in the upper trunnion collar is about 60 times lower than the tensile yield strength of Alloy 22 (310 MPa), which allows larger stress design safety factors.

The large margin of safety indicates that the waste package lifting features may withstand dynamic loads, reducing the probability of the occurrence of a design-basis event. This demonstrates the design compliance with Criterion 1.2.1.17. (reference “Design Analysis for the Defense High-Level Waste Disposal Container,” Section 6.3).

2.5.1.18 Withstand Handling Environments (Criterion 1.2.1.18)

The calculation entitled “Waste Package Lifting Calculation” demonstrates the ability to safely lift and handle the waste package in both horizontal and vertical orientations using the trunnion rings attached at the upper and lower regions of the waste package. These trunnion rings are removed after the waste package is placed on the emplacement pallet; therefore, the use of such rings does not create a site for cracking due to crevice corrosion. Further, the trunnion rings are attached to a corresponding built-up area on the waste package and will not induce stresses that might exacerbate corrosion of the outer shell. This demonstrates compliance with Criterion 1.2.1.18 (reference “Design Analysis for the Defense High-Level Waste Disposal Container,” Section 6.3).

2.5.1.19 Use of Non-combustible and Heat Resistant Materials (Criterion 1.2.1.19)

It may be demonstrated by inspection of the sketches in “Design Analysis for the Defense High-Level Waste Disposal Container” (Attachment III) that the material call-outs for all components of the waste package are metallic and, hence, non-combustible. Similarly, the metals selected, which are not necessarily refractory, are resistant to heat. In addition, the waste form canisters and their internal components must conform to the “Waste Acceptance System Requirements Document” (Section 4.2.2), which requires the waste form to be rendered non-

combustible (reference “Design Analysis for the Defense High-Level Waste Disposal Container,” Section 6.3).

2.5.1.20 Exclusion of Explosive or Pyrophoric Materials (Criterion 1.2.1.20)

It may be demonstrated by inspection of the sketches in “Design Analysis for the Defense High-Level Waste Disposal Container” (Attachment III) that the material call-outs for all components of the waste package exclude explosive and pyrophoric materials. In addition, the waste form canisters and their internal components must conform to the “Waste Acceptance System Requirements Document” (Section 4.2.2), which precludes the use of these materials (reference “Design Analysis for the Defense High-Level Waste Disposal Container,” Section 6.3).

2.5.1.21 Exclusion of Free Liquids (Criterion 1.2.1.21)

It may be demonstrated by inspection of the sketches in “Design Analysis for the Defense High-Level Waste Disposal Container” (Attachment III) that the material call-outs for all components of the waste package exclude the use of free liquids. In addition, the waste form canisters and their internal components must conform to the “Waste Acceptance System Requirements Document” (Section 4.2.2), which precludes the use of these materials (reference “Design Analysis for the Defense High-Level Waste Disposal Container,” Section 6.3).

2.5.1.22 Manufacturing Residual Tensile Stresses of the Outer Barrier (Criterion 1.2.1.22)

Tensile stresses are highest in the welds of the disposal container. The tensile stresses in the closure weld were examined in the calculation entitled “Residual Stress Minimization of Waste Packages from Induction Annealing.” This calculation looked at five different weld designs to determine which offered the best induction annealing stress relief. Design #5 outperformed the others with a calculated residual stress field after the annealing process that was 5.8 mm in depth. As a result, design #5 was chosen as the closure weld design. The calculation demonstrates the method that will be used to show compliance with Criterion 1.2.1.22.

2.5.1.23 Static Loads in the Outer Barrier at the Interface with the Emplacement Pallet (Criterion 1.2.1.23)

The calculation “Tensile Stresses Developing in an Outer Shell of a Waste Package Mounted on an Emplacement Pallet” demonstrates that the maximum stress intensities in the waste package outer barrier Alloy 22 are 17 MPa (tangential) and 7 MPa (axial). These stress intensities are less than 10 percent of the yield strength (310 MPa) of Alloy 22. The criterion is satisfied.

2.5.1.24 Tensile Stresses in the Outer Barrier during a Seismic Event (Criterion 1.2.1.24)

Calculation in progress to demonstrate compliance of a preclosure seismic event. Postclosure seismic events will not be demonstrated for SR.

2.5.2 Safety Criteria

2.5.2.1 Preclosure Rock Fall Without Breach (Criterion 1.2.2.1.1)

The 21-PWR Absorber Plate disposal container design is the representative waste package for preclosure rockfall. It is the most common package and hence, the most likely to suffer a rock fall event. Therefore, the uncanistered SNF disposal container design addresses this criterion rather than this document (reference "Design Analysis for the Defense High-Level Waste Disposal Container," Table 15).

2.5.2.2 Preclosure Impact on the End of the Waste Package Without Breach (Criterion 1.2.2.1.2)

This design criterion will not be addressed for Site Recommendation (reference "Design Analysis for the Defense High-Level Waste Disposal Container," Table 15).

2.5.2.3 Preclosure Vertical Drop Without Breach (Criterion 1.2.2.1.3)

The naval SNF long disposal container is the heaviest design and has the highest internal load; therefore, it will have the highest stresses in the lids during a vertical drop. Therefore, the naval SNF disposal container design addresses this criterion rather than this document (reference "Design Analysis for the Defense High-Level Waste Disposal Container," Table 15).

2.5.2.4 Preclosure Horizontal Drop Without Breach (Criterion 1.2.2.1.4)

The Naval SNF Disposal Container System is being evaluated for this criterion (reference "Design Analysis for the Defense High-Level Waste Disposal Container," Table 15).

2.5.2.5 Horizontal Drop (Criterion 1.2.2.1.5)

The 44-BWR, which is part of the Uncanistered SNF Disposal Container System, is being evaluated for this criterion (reference "Design Analysis for the Defense High-Level Waste Disposal Container," Table 15).

2.5.2.6 Preclosure Tip Over and Slap Down Without Breach (Criterion 1.2.2.1.6)

The 21-PWR Absorber Plate disposal container design, which is part of the Uncanistered SNF Disposal Container System, is the representative waste

package for the pre-closure tip over and slap down evaluation. It is the most common waste package and hence, the most likely to suffer a tip over and slap down design basis event. Therefore, the 21-PWR Absorber Plate disposal container design rather than the DHLW waste package will be evaluated for Site Recommendation (reference "Design Analysis for the Defense High-Level Waste Disposal Container," Table 15).

2.5.2.7 Withstand a Design Basis Earthquake (Criterion 1.2.2.1.7)

This design criterion will not be addressed for Site Recommendation (reference "Design Analysis for the Defense High-Level Waste Disposal Container," Table 15).

2.5.2.8 Sustain Preclosure Missile Impact Without Breach (Criterion 1.2.2.1.8)

The criterion to withstand a 0.5-kg missile impact (1 cm in diameter) travelling at 5.7 m/sec has been demonstrated by the 5-DHLW/DOE SNF short design. A missile with a velocity of 5.7 m/sec has 1.7 percent of the necessary impact velocity to compromise the waste package integrity (reference "Design Analysis for the Defense High-Level Waste Disposal Container," Section 6.3).

2.5.2.9 Transporter Runaway (Criterion 1.2.2.1.9)

This design criterion will not be addressed for Site Recommendation (reference "Design Analysis for the Defense High-Level Waste Disposal Container," Table 15).

2.5.2.10 Sustain Maximum Internal Pressure Limit (Criterion 1.2.2.1.10)

This calculation uses a closed-form solution to the problem of cylindrical shell subject to internal pressure load to determine the maximum stresses in the junction. The inner lid is assumed to fail before the outer lid; therefore, no structural credit is taken for the outer lid. Evaluations are performed over uniform waste package temperature ranging from 20 degrees C to 600 degrees C. The peak stresses (membrane and bending) at the junction of the shell and the lid are compared to the ultimate tensile stress.

The internal pressure of a 21-PWR Absorber Plate waste package was assumed inside the codisposal waste package. The internal pressures, peak stresses (membrane and bending) at the junction of the shell and lid, and the "1995 ASME Boiler and Pressure Vessel Code" requirements on membrane and bending stresses for different temperatures are presented in Table 13. The resulting stresses for the waste package inner shell are less than 90 percent of the ultimate tensile strength of the stainless steel (SA-240 S31600; 316NG); therefore, the waste package will not breach as a result of pressurization and the criterion is met. (reference "Design Analysis for the Defense High-Level Waste Disposal Container," Section 6.2.2).

Table 13. Variation of Stress from Internal Pressure with Temperature

Temperature	S_{m+b} ^a	$0.9 \cdot S_u$
20°C	130 MPa	465 MPa
200°C	211 MPa	446 MPa
400°C	298 MPa	443 MPa
600°C	384 MPa	370 MPa

^a Membrane stress plus bending stress.

2.5.2.11 Hypothetical Fire (Criterion 1.2.2.1.11)

This design criterion will not be addressed for Site Recommendation (reference “Design Analysis for the Defense High-Level Waste Disposal Container,” Table 15).

2.5.2.12 Preclosure Criticality (Criterion 1.2.2.1.12)

The highest k_{eff} for the system occurs for the most reactive fuel and the optimum moderation. Therefore, the criticality calculations consider various TRIGA fuel types and several water densities. Analyses of intact fuel rods indicated that 4-rod cluster type rods, Fuel Life Improvement Program (FLIP), standard streamline type rods, and FLIP-LEU-I are below criticality. The maximum k_{eff} is 0.793 for the TRIGA-SS FLIP and FLIP in a 4-rod cluster type rods in a waste package flooded with water at 1-gram/cm³ density (reference “Design Analysis for the Defense High-Level Waste Disposal Container,” Section 6.2.5.2).

2.5.2.13 Postclosure Criticality (Criterion 1.2.2.1.13)

The 21 PWR Absorber Plate waste package has a higher probability for releasing radionuclides to the environment. Therefore, the 21-PWR rather than the DHLW waste package will be evaluated for Site Recommendation (reference “Design Analysis for the Defense High-Level Waste Disposal Container,” Table 15).

2.5.2.14 Postclosure Radionuclide Inventory (Criterion 1.2.2.1.14)

This design criterion will not be addressed for Site Recommendation.

2.5.3 System Environment Criteria

2.5.3.1 Emplacement Drift Environment (Criterion 1.2.3.1)

This design criterion will not be addressed for Site Recommendation (reference “Design Analysis for the Defense High-Level Waste Disposal Container,” Table 15).

2.5.4 System Interfacing Criteria

2.5.4.1 Limitation of Waste Package Surface Radiation Dose Rate (Criterion 1.2.4.1)

The second-level confidence interval for the estimate of the maximum dose rates on the external surfaces of the 5-DHLW/TRIGA SNF short waste package is 105 rem/hr. Criterion 1.2.4.1 specifies the maximum dose rate as 1,450 rem/hr. Compliance with this criterion has been demonstrated (reference "Design Analysis for the Defense High-Level Waste Disposal Container," Section 6.3).

2.5.4.2 Maximum Thermal Output of Waste Package (Criterion 1.2.4.2)

The maximum thermal output of the 5-DHLW-DOE SNF short waste package is 9.16 kW, which is below the 11.8 kW limit and in compliance with this criterion (reference "Design Analysis for the Defense High-Level Waste Disposal Container," Section 6.3).

2.5.4.3 Limitation on the Quantity of the Waste Form (Criterion 1.2.4.3)

The full inventory of the DOE SNF, DHLW, HLW, and immobilized plutonium in disposable canisters will be accommodated by 1,530-5-DHLW/DOE SNF-short waste packages, 2,821-5-DHLW/DOE SNF-long waste packages, and 199-2-MCO/2-DHLW waste packages (reference "Design Analysis for the Defense High-Level Waste Disposal Container," Section 6.3).

2.5.4.4 Vertical Loading and Sealing of Waste Packages (Criterion 1.2.4.4)

It may be demonstrated by inspection of the sketch in the "Design Analysis for the Defense High-Level Waste Disposal Container" (Attachment I) that the waste package may be loaded in a vertical attitude (reference "Design Analysis for the Defense High-Level Waste Disposal Container," Section 6.3).

2.5.4.5 Allow Horizontal and Vertical Handling of the Waste Package (Criterion 1.2.4.5)

The calculation entitled "Waste Package Lifting Calculation" demonstrates the ability to safely lift and handle the waste package in both horizontal and vertical orientations using the trunnion rings attached at the upper and lower regions of the waste package (reference "Design Analysis for the Defense High-Level Waste Disposal Container," Section 6.3).

2.5.4.6 Welding Times (Criterion 1.2.4.6)

This design criterion will not be addressed for Site Recommendation (reference "Design Analysis for the Defense High-Level Waste Disposal Container," Table 15).

2.5.5 Codes and Standards Criteria

2.5.5.1 “1995 ASME Boiler and Pressure Vessel Code” (Section III, Div. 1, Sub-section NG-1995) (Criterion 1.2.6.1)

There are no codes or standards that apply directly to the design of disposal containers; however, the “1995 ASME Boiler and Pressure Vessel Code” has been chosen as a guide for setting stress limits for the waste package components. Applications of subsections of Section III of the “1995 ASME Boiler and Pressure Vessel Code” are shown in Table 14 (reference “Design Analysis for the Defense High-Level Waste Disposal Container,” Section 4.3).

Table 14. Applicability of “1995 ASME Boiler and Pressure Vessel Code”

Analysis Type	Component	Section III, Subsection Applied	Service Limits [a]
Static	Barriers	Subsection NB	Level A
	Basket	Subsection NG	Level A
Seismic	Barriers	Subsection NB, Appendix F	Level D
	Basket	Subsection NG, Appendix F	Level D
Rockfall, Internal Pressure, Missile Impact	Barriers	Subsection NB, Appendix F	Level D

[a] Level A Service Limits are for normal operation; Level D Service Limits are for off-normal conditions.

As may be seen from Table 14, Subsection NG is used for operations consistent with normal activities with the Level A Service Limits. From the code, the limitation on membrane and bending stresses at Level A are:

$$P_m + P_b = 1.5 \cdot S_m$$

Here, P_m is the membrane stress, P_b is the bending stress and S_m is the design stress for the material. For design purposes, the design stress is assumed to be 2/3 of the yield stress; therefore, the allowable total stress - including both membrane and bending - is equal to the yield stress (reference “Design Analysis for the Defense High-Level Waste Disposal Container,” Section 4.3).

2.5.5.2 “1995 ASME Boiler and Pressure Vessel Code” (Section III, Div. 1, Sub-section NB-1995) (Criterion 1.2.6.2)

For Level D Service Limits, Sub-section NB of the “1995 ASME Boiler and Pressure Vessel Code” are used, as shown in Table 14. From the code, the limitation on membrane and bending stresses at Level D are:

$$P_m + P_b < 0.9 \cdot S_u$$

Here, S_u is the ultimate tensile strength of the material (reference “Design Analysis for the Defense High-Level Waste Disposal Container,” Section 4.3).

2.5.5.3 “Nuclear Criticality Control of Special Actinide Elements” (ANSI/ANS-8.15-1981) (Criterion 1.2.6.3)

ANSI/ANS-8.15-1981 is specifically cited in the “Disposal Criticality Analysis Methodology Topical Report” (Section 2.3.2) as a governing requirements document. Since this document defines the methodology used for all criticality evaluations, this standard has been applied to all criticality results cited in this document (reference “Design Analysis for the Defense High-Level Waste Disposal Container,” Section 4.3.2).

2.5.5.4 “Nuclear Criticality Safety in Operations with Fissionable Materials Outside Reactors” (ANSI/ANS-8.1-1998) (Criterion 1.2.6.4)

ANSI/ANS-8.1-1983 is specifically cited in the “Disposal Criticality Analysis Methodology Topical Report” (Section 2.3.2) as a governing requirements document. Since this document defines the methodology used for all criticality evaluations, this standard has been applied to all criticality results cited in this document (reference “Design Analysis for the Defense High-Level Waste Disposal Container,” Section 4.3.2).

2.5.5.5 “Criteria for Nuclear Criticality Safety Controls in Operations with Shielding and Confinement” (ANSI/ANS-8.10-1983) (Criterion 1.2.6.5)

ANSI/ANS-8.10-1983 is specifically cited in the “Disposal Criticality Analysis Methodology Topical Report” (Section 2.3.2) as a governing requirements document. Since this document defines the methodology used for all criticality evaluations, this standard has been applied to all criticality results cited in this document (reference “Design Analysis for the Defense High-Level Waste Disposal Container,” Section 4.3.2).

2.5.5.6 “Criticality Safety Criteria for the Handling, Storage, and Transportation of LWR Fuel Outside Reactors” (ANSI/ANS-8.17-1984) (Criterion 1.2.6.6)

ANSI/ANS-8.17-1984 is specifically cited in the “Disposal Criticality Analysis Methodology Topical Report” (Section 2.3.2) as a governing requirements document. Since this document defines the methodology used for all criticality evaluations, this standard has been applied to all criticality results cited in this document (reference “Design Analysis for the Defense High-Level Waste Disposal Container,” Section 4.3.2).

3. SYSTEM OPERATIONS

This section will be completed in a later revision.

4. SYSTEM MAINTENANCE

This section will be completed in a later revision.

APPENDIX A CRITERION BASIS STATEMENTS

This section presents the criterion basis statements for criteria in Section 1.2. Descriptions of the traces to “Monitored Geologic Repository Requirements Document” (MGR RD) and “Revised Interim Guidance Pending Issuance of New U.S. Nuclear Regulatory Commission (NRC) Regulations (Revision 01, July 22, 1999), for Yucca Mountain, Nevada” are shown as applicable. In anticipation of the interim guidance being promulgated as a Code of Federal Regulations, it will be referred to as “10 CFR 63” in this system description document.

1.2.1.1 Criterion Basis Statement

I. Criterion Need Basis

This requirement, in conjunction with Criterion 1.2.1.2, establishes the types of high-level waste (HLW) that the suite of defense HLW disposal containers must be designed to contain. This requirement only identifies the type of canisters to be used in design. Additional information is provided (size, weight, and material) that may be used in design.

This criterion provides a lower level decomposition of MGR RD 3.2.A by specifying the waste forms that will make up the 640 MTU of commercial HLW and 4,027 MTU of defense HLW to be disposed of at the Monitored Geologic Repository (MGR). The commercial HLW is produced by West Valley Demonstration Project, and the defense HLW is produced by Hanford, Savannah River Site, and Idaho National Engineering and Environmental Laboratory.

II. Criterion Performance Parameter Basis

Hanford long canister overall height and weight are from “Incorporating Hanford 15 Foot (4.5 Meter) Canister Into Civilian Radioactive Waste Management System (CRWMS) Baseline.”

Remaining information is obtained from “Characteristics of Potential Repository Wastes” (Volume 1, Table 3.1.1, Figure 3.2.1, Figure 3.3.1, and Figure 3.4.2) (TBV-455). This information includes the Hanford Site long canister outside diameter, neck outside diameter, and canister material, because these are not expected to change from the short canister design, as noted in “Incorporating Hanford 15 Foot (4.5 Meter) Canister Into Civilian Radioactive Waste Management System (CRWMS) Baseline”: “The specifications for the 4.5 m canistered waste form are expected to remain the same in all areas except those associated with the increased canister length, weight, heat generation, and fill height.”

1.2.1.2 Criterion Basis Statement

I. Criterion Need Basis

This requirement, in conjunction with Criterion 1.2.1.1, establishes the types of waste (U.S. Department of Energy [DOE] Spent Nuclear Fuel [SNF]) that the suite of defense

HLW disposal containers must be designed to contain. Co-disposal of DOE SNF and HLW in the defense HLW disposal container is assumed in “Waste Quantity, Mix and Throughput Study Report” (Section 5.4.2).

This criterion provides a lower level decomposition of MGR RD 3.2 A by specifying the waste forms that will make up part of the 2,437 MTU of DOE SNF to be disposed of at the MGR.

II. Criterion Performance Parameter Basis

The DOE SNF categories are identified in “DOE Spent Nuclear Fuel Grouping in Support of Criticality, DBE, TSPA-LA” (Figure 2, Table 1, and Section 6.6).

The DOE SNF canister characteristics are obtained from “U.S. Department of Energy Spent Nuclear Fuel to the Monitored Geologic Repository for Mechanical and Envelope Interfaces,” Volume 1 of “Integrated Interface Control Document” (Figures B-5, B-6, B-10, and B-11), and from “N Reactor (U-metal) Fuel Characteristics for Disposal Criticality Analysis” (Figure 4-1 and Table 4-1).

1.2.1.3 Criterion Basis Statement

I. Criterion Need Basis

This criterion is needed to define the overall level of performance of the repository to which this system will contribute. This criterion supports MGR RD 3.1.C and 10 CFR 63.113(b).

II. Criterion Performance Parameter Basis

The performance parameters are taken from 10 CFR 63.113(b).

1.2.1.4 Criterion Basis Statement

I. Criterion Need Basis

This criterion is required for the system to comply with management direction put into effect via the “Monitored Geologic Repository Project Description Document,” which places constraints on the materials of construction and the nominal material thickness of each of two concentric cylinders that make up the disposal container. This criterion supports MGR RD 3.1.C. This criterion is also a consideration of 10 CFR 63.113(a), which requires the MGR include multiple barriers, including an engineered barrier system.

II. Criterion Performance Parameter Basis

The material and nominal thickness parameters are obtained from the “Monitored Geologic Repository Project Description Document” (Section 5.2.12).

1.2.1.6 Criterion Basis Statement

I. Criterion Need Basis

This requirement is intended to ensure that the glass transition temperature is not exceeded, in which case the glass waste could go through a change of phase from a glass to a crystalline structure. Variations in condition of the borosilicate glass affect the projected durability of vitrified HLW, and can increase the potential for unacceptable radionuclide release rates in some fraction of the inventory. This criterion supports MGR RD 3.1.C. This criterion is needed to ensure the expected annual dose to the critical group during the first 10,000 years after permanent closure does not exceed 25 mrem, as required by 10 CFR 63.113(b).

This criterion is also needed in consideration of 10 CFR 63.111(a)(2), 10 CFR 63.111(b)(2), and 10 CFR 63.112(e)(8) to ensure the disposal container system performs its intended safety function assuming the occurrence of a design basis event.

This criterion is supported by Guidance Statements 6.7g2, 6.12g1, 6.12g3, and 6.13g1 contained in the "MGR Compliance Program Guidance Package for the Defense High-Level Waste (DHLW) Disposal Container."

II. Criterion Performance Parameter Basis

The temperature value for normal conditions is taken from the "Waste Acceptance System Requirements Document," Section 4.2.3.1.G.1. The temperature value for short-term exposure to fire is derived by rounding down the glass transition temperature provided by the "Waste Acceptance System Requirements Document" (p. A-3).

1.2.1.7 Criterion Basis Statement

I. Criterion Need Basis

This criterion is required for the system to comply with management direction put into effect via the "Monitored Geologic Repository Project Description Document" (Section 5.2.23).

II. Criterion Performance Parameter Basis

N/A

1.2.1.8 Criterion Basis Statement

I. Criterion Need Basis

This requirement is a consideration of MGR RD 3.1.C and 10 CFR 63.111(a)(2) to protect against radiation exposure and release of radioactive materials during normal handling operations.

This criterion is supported by Guidance Statements 6.12g1, 6.12g3, and 6.13g1 contained in the “MGR Compliance Program Guidance Package for the Defense High-Level Waste (DHLW) Disposal Container.”

II. Criterion Performance Parameter Basis

N/A

1.2.1.9 Criterion Basis Statement

I. Criterion Need Basis

This criterion supports MGR RD 3.1.C. This requirement contributes to the ability to retrieve waste packages as required by 10 CFR 63.111(e)(1). This requirement dictates a time period in which the disposal containers must be capable of being moved after emplacement.

This criterion is supported by Guidance Statements 6.12g1 and 6.13g1 contained in the “MGR Compliance Program Guidance Package for the Defense High-Level Waste (DHLW) Disposal Container.”

II. Criterion Performance Parameter Basis

The 300-year time period is taken from MGR RD 3.2.H, which requires the MGR to support a deferral of closure for up to 300 years.

1.2.1.10 Criterion Basis Statement

I. Criterion Need Basis

This requirement is intended to preserve the waste form condition and configuration. Breach of the canisters due to oxidation/corrosion would remove the canister walls as barriers to radionuclide releases and therefore remove their contribution to overall repository performance. This criterion supports MGR RD 3.1.C. This criterion is a consideration of the waste retrievability requirement of 10 CFR 63.111(e)(1). In addition, the possibility of a breach of the disposal container due to gas generation is reduced, in consideration of 10 CFR 63.113(b).

A non-oxidizing environment is desirable to prevent early corrosion of the waste form canisters prior to waste package breach and provides defense-in-depth. It is therefore reasonable to be applied to the Defense High Level Waste disposal container design.

II. Criterion Performance Parameter Basis

The performance parameters used in this criterion are taken from the criterion analysis provided in the “Uncanistered Spent Nuclear Fuel Disposal Container System Description Document” (Appendix A, Criterion Basis Statement 1.2.1.9), which derives non-oxidizing environment characteristics. That criterion analysis derives the non-

oxidizing environment characteristics based on the emplacement of uncanistered SNF disposal containers containing commercial SNF.

An analysis to determine appropriate concentration limits for waste packages containing defense HLW, commercial HLW, and DOE SNF has not yet been performed. However, concentration limits used for uncanistered SNF disposal containers, which are to be verified, provide reasonable bases for the defense HLW disposal container.

1.2.1.11 Criterion Basis Statement

I. Criterion Need Basis

This requirement supports decontamination of the disposal container/waste package. By limiting surface roughness of the disposal container, the decontamination process will not be impeded. This requirement is derived from the "Mined Geologic Disposal System Functional Analysis Document," function 1.4.3.2.2.4.5, and "Design Criteria for an Independent Spent Fuel Storage Installation (Dry Type)" (ANSI/ANS-57.9-1992), Section 6.2.2.1.2(5).

This criterion supports MGR RD 3.1.C. Limiting surface roughness may also reduce the time required to perform work in the vicinity of radioactive materials, which is required by 10 CFR 63.112(e)(2).

This criterion is supported by Guidance Statement 7.1g1 contained in the "MGR Compliance Program Guidance Package for the Defense High-Level Waste (DHLW) Disposal Container."

II. Criterion Performance Parameter Basis

A published reference for the recommended surface finish of tools, equipment, casks, containers etc., which may become radioactively contaminated does not exist; therefore, the following rule of thumb based on both Commercial Nuclear and Nuclear Navy experience will be used as the basis for selecting the surface finishes. (Note: The highest number has the roughest finish.)

250 μ in: Use in applications where the item is not expected/designed to become radioactively contaminated. However, if exposed to radioactive contamination, this finish can still be decontaminated.

125 μ in: Use in applications where the item is more likely to become radioactively contaminated than the 250 case, but still not routinely exposed to contamination.

63 μ in: Use in applications where the item is expected to be routinely exposed to radioactive contamination.

The 250 μ in value is selected for the disposal container because the container is not expected to become contaminated due to waste handling operations. In addition, the

postclosure performance of one finish over another is not a distinguishing factor for long term performance in the models used for TSPA.

1.2.1.12 Criterion Basis Statement

I. Criterion Need Basis

This requirement guides disposal container design away from a design that would be difficult to decontaminate by precluding undesirable external geometries (e.g., blind holes). This requirement is intended to be assessed against the as-designed disposal container, without regard to actual disposal container use, which would preclude surface visibility (e.g., waste package emplacement on pedestals would preclude visibility of the pedestal to disposal container contact points).

Also, this criterion supports MGR RD 3.1.C. Accessibility of the waste package surface to visual inspection may reduce the time required to perform work in the vicinity of radioactive materials, which is required by 10 CFR 63.112(e)(2).

II. Criterion Performance Parameter Basis

N/A

1.2.1.13 Criterion Basis Statement

I. Criterion Need Basis

This criterion supports the tracking of all waste packages as required by MGR RD 3.1.C, MGR RD 3.3.K, and 10 CFR 63.78. This criterion also supports the MGR RD 3.1.B requirement to implement the applicable provisions of “Standards for Protection Against Radiation” (10 CFR 20). Also, identification of waste package contents may reduce the time required to perform work in the vicinity of radioactive materials, which is required by 10 CFR 63.112(e)(2).

Waste packages located in surface and subsurface facilities of the MGR are “accessible only to individuals authorized to ... work in the vicinity of the containers...” and are located in storage vaults or hot cells. Therefore, labeling of waste packages is subject to the exemptions provided by 10 CFR 20.1905(e).

II. Criterion Performance Parameter Basis

N/A

1.2.1.14 Criterion Basis Statement**I. Criterion Need Basis**

This criterion supports MGR RD 3.1.C. Label material and method of attachment to the waste package must be considered so that the waste package will not be impaired in its ability to limit the dose rate specified in 10 CFR 63.113(b).

II. Criterion Performance Parameter Basis

N/A

1.2.1.15 Criterion Basis Statement**I. Criterion Need Basis**

This requirement establishes the length of time that the labels must be legible. This requirement supports MGR RD 3.1.C and is a decomposition of 10 CFR 63.112(e)(2) in that legibility by remote means may reduce the time required to perform work in the vicinity of radioactive materials. Labels are needed to support the tracking of all waste packages as required by MGR RD 3.3.K and 10 CFR 63.78. This criterion also supports the MGR RD 3.1.D requirement to implement the applicable provisions of "Physical Protection of Plants and Materials" (10 CFR 73), Section 45(d)(1)(iii).

II. Criterion Performance Parameter Basis

N/A

1.2.1.16 Criterion Basis Statement**I. Criterion Need Basis**

This criterion supports MGR RD 3.1.C and 3.1.G. This criterion requires that the disposal container/waste package lifting features be designed to withstand handling loads and is needed to reduce the probability of the occurrence of a design basis event in consideration of 10 CFR 63.111(a)(2), 10 CFR 63.111(b)(2), and 10 CFR 63.112(e)(8). Reducing the probability of a design basis event may also reduce the time required to perform work in the vicinity of radioactive materials, which is a consideration of 10 CFR 63.112(e)(2).

II. Criterion Performance Parameter Basis

The factors-of-safety are obtained from Section 4.2.1.1 of "American National Standard for Radioactive Materials - Special Lifting Devices for Shipping Containers Weighing 10000 Pounds (4500 kg) or More" (ANSI N14.6-1993). The scope of ANSI N14.6-1993 encompasses special lifting devices and those features of the attachment members of the containers that affect the function and safety of the lift. The Yucca Mountain Project may develop (for use in its disposal container designs) different values based on loading

conditions that are representative of repository operations, if they are justified. A technical report would provide the supporting technical justification for the project-specific values along with a rationale for not using ANSI N14.6-1993. The stress design factors specified in ANSI N14.6-1993 will be used in the disposal container designs unless project-specific values are required.

1.2.1.17 Criterion Basis Statement

I. Criterion Need Basis

This criterion supports MGR RD 3.1.C and 3.1.G. This criterion requires that the disposal container/waste package lifting features be designed to withstand handling loads and is needed to reduce the probability of the occurrence of a design basis event in consideration of 10 CFR 63.111(a)(2), 10 CFR 63.111(b)(2), and 10 CFR 63.112(e)(8). Reducing the probability of a design basis event may also reduce the time required to perform work in the vicinity of radioactive materials, which is a consideration of 10 CFR 63.112(e)(2).

II. Criterion Performance Parameter Basis

The factors-of-safety are obtained from Section 4.2.1.1 of “American National Standard for Radioactive Materials - Special Lifting Devices for Shipping Containers Weighing 10000 Pounds (4500 kg) or More” (ANSI N14.6-1993). The scope of ANSI N14.6-1993 encompasses special lifting devices and those features of the attachment members of the containers that affect the function and safety of the lift. The Yucca Mountain Project may develop (for use in its disposal container designs) different values based on loading conditions that are representative of repository operations, if they are justified. A technical report would provide the supporting technical justification for the project-specific values along with a rationale for not using ANSI N14.6-1993. The stress design factors specified in ANSI N14.6-1993 will be used in the disposal container designs unless project-specific values are required.

1.2.1.18 Criterion Basis Statement

I. Criterion Need Basis

This criterion supports MGR RD 3.1.C. This criterion is needed for the disposal container/waste package to comply with 10 CFR 63.111(a)(2), which requires the disposal container system perform its intended safety function during normal operations.

This criterion is supported by Guidance Statements 6.12g3 and 6.13g1 contained in the “MGR Compliance Program Guidance Package for the Defense High-Level Waste (DHLW) Disposal Container.” The Guidance Statements require the disposal container be designed considering normal loading conditions.

II. Criterion Performance Parameter Basis

N/A

1.2.1.19 Criterion Basis Statement

I. Criterion Need Basis

This criterion is needed in consideration of thermal loads and fire hazards in support of MGR RD 3.1.C, 10 CFR 63.111(a)(2), 10 CFR 63.111(b)(2), and 10 CFR 63.112(e)(8), which require the disposal container system perform its intended safety function assuming the occurrence of design basis events.

II. Criterion Performance Parameter Basis

N/A

1.2.1.20 Criterion Basis Statement

I. Criterion Need Basis

This criterion is needed in consideration of fire hazards (pyrophoric materials), explosion hazards (explosive materials), and thermal loads (conditions resulting in the ignition of a pyrophoric material and the results of an explosion or fire). This criterion supports MGR RD 3.1.C, 10 CFR 63.111(a)(2), 10 CFR 63.111(b)(2), and 10 CFR 63.112(e)(8), which require the disposal container system perform its intended safety function assuming the occurrence of design basis events.

II. Criterion Performance Parameter Basis

N/A

1.2.1.21 Criterion Basis Statement

I. Criterion Need Basis

This criterion is needed to support the functions of the waste package to prevent adverse reactions involving the waste form and to provide conditions needed to maintain the physical and chemical stability of the waste form.

II. Criterion Performance Parameter Basis

N/A

1.2.1.22 Criterion Basis Statement

I. Criterion Need Basis

This criterion is needed to ensure residual stresses do not initiate stress corrosion cracking in the waste package.

II. Criterion Performance Parameter Basis

The stress limit of 10 percent of the outer material yield strength is provided in “Waste Package Degradation Process Model Report,” Section 3.1.9.4.

1.2.1.23 Criterion Basis Statement

I. Criterion Need Basis

This criterion is needed to ensure static loads do not initiate stress corrosion cracking in the waste package.

II. Criterion Performance Parameter Basis

The stress limit of 10 percent of the outer material yield strength is provided in “Waste Package Degradation Process Model Report,” Section 3.1.9.4.

1.2.1.24 Criterion Basis Statement

I. Criterion Need Basis

This criterion is needed to ensure seismic loads do not result in permanent strains that could initiate stress corrosion cracking in the waste package. Maintaining stresses below yield stress ensures that permanent strains are not induced.

II. Criterion Performance Parameter Basis

N/A

1.2.2.1.1 Criterion Basis Statement

I. Criterion Need Basis

This criterion supports MGR RD 3.1.C and 3.1.G. This criterion is needed in consideration of 10 CFR 63.111(a)(2), 10 CFR 63.111(b)(2), and 10 CFR 63.112(e)(8) and to ensure the disposal container system performs its intended safety function assuming the occurrence of a design basis event. The general wording for this requirement is taken from “Nuclear Safety Criteria for Disposal Container System Description Documents” (Attachment 1, p. 1) (Input Transmittal RSO-RSO-99333.Tb).

This criterion is supported by Guidance Statements 6.12g1, 6.12g3, and 6.13g1 contained in the “MGR Compliance Program Guidance Package for the Defense High-Level Waste (DHLW) Disposal Container.”

II. Criterion Performance Parameter Basis

The event parameters are taken from “Preclosure Design Basis Events Related to Waste Packages” (Section 7.2.1).

1.2.2.1.2 Criterion Basis Statement

I. Criterion Need Basis

This criterion supports MGR RD 3.1.C and 3.1.G. This criterion is needed in consideration of 10 CFR 63.111(a)(2), 10 CFR 63.111(b)(2), and 10 CFR 63.112(e)(8) and to ensure the disposal container system performs its intended safety function assuming the occurrence of a design basis event. The general wording for this requirement is taken from “Nuclear Safety Criteria for Disposal Container System Description Documents” (Attachment 1, p. 1) (Input Transmittal RSO-RSO-99333.Tb).

This criterion is supported by Guidance Statements 6.12g1, 6.12g3, and 6.13g1 contained in the “MGR Compliance Program Guidance Package for the Defense High-Level Waste (DHLW) Disposal Container.”

II. Criterion Performance Parameter Basis

The event parameters are taken from “Nuclear Safety Criteria for Disposal Container System Description Documents” (Attachment 1, p. 1) (Input Transmittal RSO-RSO-99333.Tb).

1.2.2.1.3 Criterion Basis Statement

I. Criterion Need Basis

This criterion supports MGR RD 3.1.C and 3.1.G. This criterion is needed in consideration of 10 CFR 63.111(a)(2), 10 CFR 63.111(b)(2), and 10 CFR 63.112(e)(8) and to ensure the disposal container system performs its intended safety function assuming the occurrence of a design basis event. The general wording for this requirement is taken from “Nuclear Safety Criteria for Disposal Container System Description Documents” (Attachment 1, p. 1) (Input Transmittal RSO-RSO-99333.Tb).

This criterion is supported by Guidance Statements 6.7g1, 6.12g1, 6.12g3, and 6.13g1 contained in the “MGR Compliance Program Guidance Package for the Defense High-Level Waste (DHLW) Disposal Container.”

II. Criterion Performance Parameter Basis

The event parameters are taken from “Nuclear Safety Criteria for Disposal Container System Description Documents” (Attachment 1, p. 1) (Input Transmittal RSO-RSO-99333.Tb).

1.2.2.1.4 Criterion Basis Statement

I. Criterion Need Basis

This criterion supports MGR RD 3.1.C and 3.1.G. This criterion is needed in consideration of 10 CFR 63.111(a)(2), 10 CFR 63.111(b)(2), and 10 CFR 63.112(e)(8)

and to ensure the disposal container system performs its intended safety function assuming the occurrence of a design basis event. The general wording for this requirement is taken from “Nuclear Safety Criteria for Disposal Container System Description Documents” (Attachment 1, p. 1) (Input Transmittal RSO-RSO-99333.Tb).

This criterion is supported by Guidance Statements 6.7g1, 6.12g1, 6.12g3, and 6.13g1 contained in the “MGR Compliance Program Guidance Package for the Defense High-Level Waste (DHLW) Disposal Container.”

II. Criterion Performance Parameter Basis

The event parameters are taken from “Nuclear Safety Criteria for Disposal Container System Description Documents” (Attachment 1, p. 1) (Input Transmittal RSO-RSO-99333.Tb).

1.2.2.1.5 Criterion Basis Statement

I. Criterion Need Basis

This criterion supports MGR RD 3.1.C and 3.1.G. This criterion is needed in consideration of 10 CFR 63.111(a)(2), 10 CFR 63.111(b)(2), and 10 CFR 63.112(e)(8) and to ensure the disposal container system performs its intended safety function assuming the occurrence of a design basis event. The general wording for this requirement is taken from “Nuclear Safety Criteria for Disposal Container System Description Documents” (Attachment 1, p. 1) (Input Transmittal RSO-RSO-99333.Tb).

This criterion is supported by Guidance Statements 6.7g1, 6.12g1, 6.12g3, and 6.13g1 contained in the “MGR Compliance Program Guidance Package for the Defense High-Level Waste (DHLW) Disposal Container.”

II. Criterion Performance Parameter Basis

The drop height is to be determined.

1.2.2.1.6 Criterion Basis Statement

I. Criterion Need Basis

This criterion supports MGR RD 3.1.C and 3.1.G. This criterion is needed in consideration of 10 CFR 63.111(a)(2), 10 CFR 63.111(b)(2), and 10 CFR 63.112(e)(8) and to ensure the disposal container system performs its intended safety function assuming the occurrence of a design basis event. The general wording for this requirement is taken from “Nuclear Safety Criteria for Disposal Container System Description Documents” (Attachment 1, p. 1) (Input Transmittal RSO-RSO-99333.Tb).

This criterion is supported by Guidance Statements 6.12g1, 6.12g3, and 6.13g1 contained in the “MGR Compliance Program Guidance Package for the Defense High-Level Waste (DHLW) Disposal Container.”

II. Criterion Performance Parameter Basis

The event parameters are taken from “Nuclear Safety Criteria for Disposal Container System Description Documents” (Attachment 1, p. 1) (Input Transmittal RSO-RSO-99333.Tb).

1.2.2.1.7 Criterion Basis Statement

I. Criterion Need Basis

This criterion supports MGR RD 3.1.C and 3.1.G. This criterion is needed in consideration of 10 CFR 63.111(a)(2), 10 CFR 63.111(b)(2), and 10 CFR 63.112(e)(8) and to ensure the disposal container system performs its intended safety function assuming the occurrence of a design basis event. The general wording for this requirement is taken from “Nuclear Safety Criteria for Disposal Container System Description Documents” (Attachment 1, p. 1) (Input Transmittal RSO-RSO-99333.Tb).

This criterion is supported by Guidance Statements 6.12g1, 6.12g3, and 6.13g1 contained in the “MGR Compliance Program Guidance Package for the Defense High-Level Waste (DHLW) Disposal Container.”

II. Criterion Performance Parameter Basis

The event parameters are taken from “Nuclear Safety Criteria for Disposal Container System Description Documents” (Attachment 1, p. 1) (Input Transmittal RSO-RSO-99333.Tb).

1.2.2.1.8 Criterion Basis Statement

I. Criterion Need Basis

This criterion supports MGR RD 3.1.C and 3.1.G. This criterion is needed in consideration of 10 CFR 63.111(a)(2), 10 CFR 63.111(b)(2), and 10 CFR 63.112(e)(8) and to ensure the disposal container system performs its intended safety function assuming the occurrence of a design basis event. The general wording for this requirement is taken from “Nuclear Safety Criteria for Disposal Container System Description Documents” (Attachment 1, p. 2) (Input Transmittal RSO-RSO-99333.Tb).

This criterion is supported by Guidance Statements 6.12g1, 6.12g3, and 6.13g1 contained in the “MGR Compliance Program Guidance Package for the Defense High-Level Waste (DHLW) Disposal Container.”

II. Criterion Performance Parameter Basis

The event parameters are taken from “Nuclear Safety Criteria for Disposal Container System Description Documents” (Attachment 1, p. 2) (Input Transmittal RSO-RSO-99333.Tb).

1.2.2.1.9 Criterion Basis Statement**I. Criterion Need Basis**

This criterion supports MGR RD 3.1.C and 3.1.G. This criterion is needed in consideration of 10 CFR 63.111(a)(2), 10 CFR 63.111(b)(2), and 10 CFR 63.112(e)(8) and to ensure the disposal container system performs its intended safety function assuming the occurrence of a design basis event. The general wording for this requirement is taken from “Nuclear Safety Criteria for Disposal Container System Description Documents” (Attachment 1, p. 2) (Input Transmittal RSO-RSO-99333.Tb).

This criterion is supported by Guidance Statements 6.12g1, 6.12g3, and 6.13g1 contained in the “MGR Compliance Program Guidance Package for the Defense High-Level Waste (DHLW) Disposal Container.”

II. Criterion Performance Parameter Basis

The event parameters are taken from “Nuclear Safety Criteria for Disposal Container System Description Documents” (Attachment 1, p. 2) (Input Transmittal RSO-RSO-99333.Tb).

1.2.2.1.10 Criterion Basis Statement**I. Criterion Need Basis**

This criterion supports MGR RD 3.1.C and 3.1.G. This criterion is needed in consideration of 10 CFR 63.111(a)(2), 10 CFR 63.111(b)(2), and 10 CFR 63.112(e)(8) and to ensure the disposal container system performs its intended safety function assuming the occurrence of a design basis event. The general wording for this requirement is taken from “Nuclear Safety Criteria for Disposal Container System Description Documents” (Attachment 1, p. 2) (Input Transmittal RSO-RSO-99333.Tb).

This criterion is supported by Guidance Statements 6.12g1, 6.12g3, and 6.13g1 contained in the “MGR Compliance Program Guidance Package for the Defense High-Level Waste (DHLW) Disposal Container.”

II. Criterion Performance Parameter Basis

The event parameters have not been determined.

1.2.2.1.11 Criterion Basis Statement**I. Criterion Need Basis**

This criterion supports MGR RD 3.1.C and 3.1.G. This criterion is needed in consideration of 10 CFR 63.111(a)(2), 10 CFR 63.111(b)(2), and 10 CFR 63.112(e)(8) and to ensure the disposal container system performs its intended safety function assuming the occurrence of a design basis event. This criterion is in consideration of a

fire event that is defined in “Packaging and Transportation of Radioactive Materials” (10 CFR 71), Section 73(c)(4).

Until a comprehensive analysis of fire hazards at the MGR is performed and establishes the credibility and/or magnitude of a design basis fire for the waste package, the hypothetical fire criteria for transportation casks, from 10 CFR 71.73(c)(4), is assumed. Therefore, this criterion remains to be verified.

The fire event is defined as exposure of the waste package fully engulfed in an average flame temperature of at least 800 degrees C (1,475 degrees F) for a period of 30 minutes, with an average emissivity coefficient of at least 0.9. For purposes of calculation, the surface absorptivity shall be either that value which the waste package may be expected to possess if exposed to the fire specified or 0.8, whichever is greater, and the convective coefficient shall be that value which may be demonstrated to exist if the waste package were exposed to the fire specified.

The general wording for this requirement is taken from “Nuclear Safety Criteria for Disposal Container System Description Documents” (Attachment 1, p. 2) (Input Transmittal RSO-RSO-99333.Tb).

This criterion is supported by Guidance Statements 6.7g2, 6.12g1, 6.12g3, and 6.13g1 contained in the “MGR Compliance Program Guidance Package for the Defense High-Level Waste (DHLW) Disposal Container.”

II. Criterion Performance Parameter Basis

The criterion is taken from “Nuclear Safety Criteria for Disposal Container System Description Documents” (Attachment 1, p. 2) (Input Transmittal RSO-RSO-99333.Tb).

1.2.2.1.12 Criterion Basis Statement

I. Criterion Need Basis

This criterion supports MGR RD 3.1.C and 3.1.G. This requirement applies the criticality requirement from 10 CFR 63.112(e)(6) to the disposal container/waste package design during the preclosure period.

The general wording for this requirement is modified from “Nuclear Safety Criteria for Disposal Container System Description Documents” (Attachment 1, p. 2) (Input Transmittal RSO-RSO-99333.Tb). The reference provides input regarding Design Basis Events, therefore this requirement partially supports 10 CFR 63.111(a)(2), 10 CFR 63.111(b)(2), and 10 CFR 63.112(e)(8).

This criterion is supported by Guidance Statements 6.12g1 and 6.13g1 contained in the “MGR Compliance Program Guidance Package for the Defense High-Level Waste (DHLW) Disposal Container.”

II. Criterion Performance Parameter Basis

The performance parameter for this requirement is taken from “Guidance on the Regulatory Requirements for Criticality Analysis of Fuel Storage at Light-Water Reactor Power Plants” (p. 5).

During the preclosure period, the disposal container/waste package shall be designed such that nuclear criticality shall not be possible unless two unlikely, independent, and concurrent or sequential changes have occurred in the conditions essential to nuclear criticality safety. Conformance to the parameter basis must be met assuming occurrence of design basis events, including those with the potential to flood the disposal container prior to its sealing. Allowance for the bias in the method of calculation and the uncertainty in the experiments used to validate the method of calculation for the calculated effective multiplication factor shall be justified in addition to conformance to the parameter basis.

1.2.2.1.13 Criterion Basis Statement

I. Criterion Need Basis

This criterion supports MGR RD 3.1.C. This criterion is a design screening component of the postclosure criticality methodology needed to ensure the expected annual dose to the critical group during the first 10,000 years after permanent closure does not exceed 25 mrem, as required by 10 CFR 63.113(b).

II. Criterion Performance Parameter Basis

The total frequency is to be measured as the sum of all of the frequencies of criticality from all waste forms and waste package designs. This total frequency is representative of the entire potential repository. Prior to License Application, conformance to the parameter basis may be established from the combination of all of the frequencies of the individual configurations which have been established to date, representative of the entire contents of the repository of the waste forms evaluated. This is established as the evaluation of all waste package and waste form configurations, which may be potentially critical, will not be completed until License Application.

This criterion, in combination with Criterion 1.2.2.1.14, is designed to ensure that criticality occurrences in the repository will not impact the TSPA assessment of expected annual dose to the critical group during the first 10,000 years after permanent closure. The establishment of the specific parameter is such that intermediate criticality risk is less than the uncertainty in the TSPA calculation of expected annual dose to the critical group. The intermediate criticality risk is defined as the sum of the products of frequency of criticality occurrence (for a single SNF waste package, as a function of time), multiplied by the radionuclide inventory (measured in curies) due to that criticality, divided by the radionuclide inventory of a single waste package, with the integral taken over the entire timeframe considered for repository performance evaluation. Both the radionuclide inventory and the increment due to criticality shall be evaluated at 1,000 years following the criticality shutdown.

1.2.2.1.14 Criterion Basis Statement

I. Criterion Need Basis

This criterion is needed to comply with MGR RD 3.1.C. The criterion is a design screening component of the postclosure disposal criticality methodology needed to ensure the expected annual dose to the critical group during the first 10,000 years after permanent closure does not exceed 25 mrem, as required by 10 CFR 63.113(b).

II. Criterion Performance Parameter Basis

The radionuclide inventory increase from a single criticality shall be determined at 1,000 years following the end of the criticality by comparing the radionuclide increment due to the criticality (at that time) divided by the total radionuclide inventory available for release and transport to the accessible environment (at that time). Available release is defined as radionuclide inventory from waste packages that have breached barriers and waste forms that have degraded sufficiently to expose the radionuclides to dissolving water.

This criterion, in combination with Criterion 1.2.2.1.13, is designed to ensure that criticality occurrences in the repository will not impact the TSPA assessment of expected annual dose to the critical group during the first 10,000 years after permanent closure. The establishment of the specific parameter, 10 percent inventory increase, is such that intermediate criticality risk is less than the uncertainty in the TSPA calculation of expected annual dose to the critical group, where intermediate criticality risk is defined in Criterion Basis Statement 1.2.2.1.13.

1.2.3.1 Criterion Basis Statement

I. Criterion Need Basis

This requirement defines the external (outside the waste package) environment for which the disposal container should be designed. This criterion supports MGR RD 3.1.C. 10 CFR 63.113(b) is traced because this requirement considers the waste package influenced emplacement drift environment and its impact on the capability of the disposal container system to limit the expected annual dose to the average member of the critical group to 25 mrem at any time during the first 10,000 years after permanent closure of the repository.

Also, in consideration of MGR RD 3.4.2.C, this criterion defines the induced handling environment (credible loads) the disposal container/waste package must withstand.

II. Criterion Performance Parameter Basis

The microbe influx, colloid concentration, temperature, and radiation parameters are taken from "Performance Allocation Study Preliminary Results" (Table 4), which is the attachment to the input transmittal entitled "Manager System Requirements/System Description Documents." The pH, humidity, and water seepage parameters are taken

from the “Monitored Geologic Repository Project Description Document” (Sections 5.2.25, 5.2.26, and 5.2.28). The induced handling environments are to be determined.

1.2.4.1 Criterion Basis Statement

I. Criterion Need Basis

This criterion supports MGR RD 3.1.B and 3.1.G. This requirement is needed as an interface between the waste package and the Waste Emplacement/Retrieval System to allow adequate waste package transporter shielding design for an acceptable dose rate at the external surfaces of the transporter (in support of “Standards for Protection Against Radiation” [10 CFR 20], Subparts A, B, and C). This requirement is not intended to yield disposal container design features that are added solely for the purpose of shielding (unshielded waste packages are recommended in the “Waste Package Size Study Report,” p. 6-5), but is intended to establish the expected maximum dose rate the Waste Emplacement/Retrieval System will be designed to reduce.

This criterion is supported by Guidance Statements 6.12g1 and 6.13g1 contained in the “MGR Compliance Program Guidance Package for the Defense High-Level Waste (DHLW) Disposal Container.”

II. Criterion Performance Parameter Basis

The maximum dose rate is taken from “Design Analysis for UCF Waste Packages,” Section 6.2.3.1. The resultant value is conservatively rounded up to the nearest 10 rem/hr.

1.2.4.2 Criterion Basis Statement

I. Criterion Need Basis

This criterion is required for the system to comply with management direction put into effect via the “Monitored Geologic Repository Project Description Document,” which places a constraint on the maximum heat output of individual waste packages. This criterion is also required to allow the design of the transporter used in the Waste Emplacement/Retrieval System. A maximum heat load criterion provides a bounding heat load that must be sustained by the transporter during emplacement operations.

II. Criterion Performance Parameter Basis

The maximum thermal output limit is obtained from the “Monitored Geologic Repository Project Description Document” (Section 5.2.13).

1.2.4.3 Criterion Basis Statement**I. Criterion Need Basis**

This requirement is needed to comply with MGR RD 3.1.A, 3.2.A, and 3.2.B. This criterion defines the split of DOE SNF disposed of in the Defense High Level Waste Disposal Container and the DOE SNF disposal container. This requirement also establishes the limits for disposal of commercial HLW and defense HLW within the Defense High Level Waste Disposal Container. Co-disposal of DOE SNF and high-level waste in the Defense High Level Waste Disposal Container is assumed in “Waste Quantity, Mix and Throughput Study Report” (Section 5.4.2).

II. Criterion Performance Parameter Basis

The total quantities of commercial HLW and defense HLW (640 MTU and 4,027 MTU, respectively) were taken from MGR RD 3.2.A. The maximum amount of DOE-owned SNF available to be disposed of at the MGR (2,437 MTU) is taken from MGR RD 3.2.B. The split of DOE SNF between the defense HLW disposal container and the DOE SNF disposal container has yet to be determined.

1.2.4.4 Criterion Basis Statement**I. Criterion Need Basis**

This criterion is needed to align the disposal container/waste package design with surface repository disposal container/waste package handling operations.

II. Criterion Performance Parameter Basis

N/A

1.2.4.5 Criterion Basis Statement**I. Criterion Need Basis**

This criterion is needed to align the disposal container/waste package design with surface repository disposal container/waste package handling operations.

II. Criterion Performance Parameter Basis

N/A

1.2.4.6 Criterion Basis Statement**I. Criterion Need Basis**

This criterion is needed to ensure the disposal container design accommodates welding and sealing equipment used by the Disposal Container Handling System and facilitates optimum welding times.

II. Criterion Performance Parameter Basis

N/A

1.2.6.1 Criterion Basis Statement**I. Criterion Need Basis**

In support of MGR RD 3.3.A, the “1995 ASME Boiler and Pressure Vessel Code” (Section III, Division 1, Subsection NG-1995) provides nuclear industry specific codes, standards and conformity assessment programs. American Society of Mechanical Engineers (ASME) codes and standards are internationally recognized for the design, manufacturing and installation of mechanical devices. Requirements set forth in “Domestic Licensing of Production and Utilization Facilities” (10 CFR 50), Section 55 are specific in the use of ASME Boiler and Pressure Codes as “quality standards commensurate with the importance of the safety function to be performed” (10 CFR 50.55(a)(1)).

II. Criterion Performance Parameter Basis

N/A

1.2.6.2 Criterion Basis Statement**I. Criterion Need Basis**

In support of MGR RD 3.3.A, the “1995 ASME Boiler and Pressure Vessel Code” (Section III, Division 1, Subsection NB-1995) provides nuclear industry specific codes, standards and conformity assessment programs. ASME codes and standards are internationally recognized for the design, manufacturing and installation of mechanical devices. Requirements set forth in “Domestic Licensing of Production and Utilization Facilities” (10 CFR 50), Section 55 are specific in the use of ASME Boiler and Pressure Codes as “quality standards commensurate with the importance of the safety function to be performed” (10 CFR 50.55(a)(1)).

II. Criterion Performance Parameter Basis

N/A

1.2.6.3 Criterion Basis Statement**I. Criterion Need Basis**

The criterion supports MGR RD 3.3.A. "Nuclear Criticality Control of Special Actinide Elements" (ANSI/ANS-8.15-1981) is cited as an industry standard used in the development of the "Disposal Criticality Analysis Methodology Topical Report."

II. Criterion Performance Parameter Basis

N/A

1.2.6.4 Criterion Basis Statement**I. Criterion Need Basis**

The criterion supports MGR RD 3.3.A. "Nuclear Criticality Safety in Operations with Fissionable Materials Outside Reactors" (ANSI/ANS-8.1-1998) is cited as an industry standard used in the development of the "Disposal Criticality Analysis Methodology Topical Report."

II. Criterion Performance Parameter Basis

N/A

1.2.6.5 Criterion Basis Statement**I. Criterion Need Basis**

The criterion supports MGR RD 3.3.A. "Criteria for Nuclear Criticality Safety Controls in Operations with Shielding and Confinement" (ANSI/ANS-8.10-1983) is cited as an industry standard used in the development of the "Disposal Criticality Analysis Methodology Topical Report."

II. Criterion Performance Parameter Basis

N/A

1.2.6.6 Criterion Basis Statement**I. Criterion Need Basis**

The criterion supports MGR RD 3.3.A. "Criticality Safety Criteria for the Handling, Storage, and Transportation of LWR Fuel Outside Reactors" (ANSI/ANS-8.17-1984) is cited as an industry standard used in the development of the "Disposal Criticality Analysis Methodology Topical Report."

II. Criterion Performance Parameter Basis

N/A

APPENDIX B ARCHITECTURE AND CLASSIFICATION

The system architecture and QA classification are identified in Table 15. The QA classifications are established in Table 1 of "Classification of the MGR Defense High-Level Waste Disposal Container System," which defines the overall system as QL-1. The next level of system architecture and assumed QA classification are identified in Table 15.

Table 15. System Architecture and Quality Assurance Classification

System Architecture	QL-1	QL-2	QL-3	CQ
Defense High Level Waste Disposal Container System	X			
5-DHLW/DOE SNF Short Disposal Container	X			
5-DHLW/DOE SNF Long Disposal Container	X			
2-MCO/2-DHLW SNF Disposal Container	X			

Note: For definition of acronyms, symbols and units, see Appendix C

APPENDIX C ACRONYMS, SYMBOLS, AND UNITS**C.1 ACRONYMS**

This section provides a listing of acronyms used in this document.

ASME	American Society of Mechanical Engineers
ASTM	American Society for Testing and Materials
BWR	boiling-water reactor
CRWMS	Civilian Radioactive Waste Management System
CQ	conventional quality
DHLW	defense high-level waste
DOE	U. S. Department of Energy
DWPF	Defense Waste Processing Facility
F	function
FFTF	Fast Flux Test Facility
FLIP	Fuel Life Improvement Program
HEU	high enriched uranium
HLW	high-level waste
IPWF	immobilized plutonium waste form
LA	License Application
LEU	low enriched uranium
MCO	Multi-Canister Overpack
MEU	medium enriched uranium
MGDS	Mined Geologic Disposal System
MGR	Monitored Geologic Repository
MGR RD	Monitored Geologic Repository Requirements Document
MOX	mixed oxide fuel
M&O	Management and Operating Contractor
NRC	U.S. Nuclear Regulatory Commission
NSNFP	National Spent Nuclear Fuel Program
PWR	pressurized-water reactor
QA	quality assurance
QL	quality level
SDD	system description document
SNF	spent nuclear fuel
SR	Site Recommendation
SRS	Savannah River Site
SS	stainless steel
TBD	to be determined
TBV	to be verified
TRIGA	Training Research Isotope-General Atomics
TSPA	Total System Performance Assessment
TSPA-SR	Total System Performance Assessment Report for Site Recommendation
UCF	uncanistered fuel
VA	Viability Assessment

C.2 SYMBOLS AND UNITS

This section provides a listing of symbols and units used in this document.

C	Celsius
°C	degrees Celsius
CO ₂	carbon dioxide
CO	carbon monoxide
F	Fahrenheit
g	acceleration due to gravity
H ₂	hydrogen
H ₂ O	water
O ₂	oxygen
cm	centimeter
cm ³	cubic centimeter
ft	feet
hr	hour
Hz	Hertz
in.	inch
kg	kilogram
km	kilometer
kW	kilowatt
k _{eff}	effective multiplication factor
lb	pound
m	meter
mg	milligram
mi	mile
ml	milliliter
mm	millimeter
MPa	megaPascals
mrem	one thousandth of a rem
MT	metric ton
MTU	metric tons uranium
P _b	bending stress
P _m	membrane stress
pH	hydrogen ion concentration potential
rem	Roentgen equivalent man
sec	second
S _m	design stress
S _{m+b}	membrane stress plus bending stress
S _u	ultimate tensile strength
yr	year
μin	microinch
μm	micrometer

APPENDIX D FUTURE REVISION RECOMMENDATIONS AND ISSUES

This appendix identifies issues and actions that require further evaluation. The disposition of these issues and actions could alter the functions and design criteria that are allocated to this system in future revisions to this document. However, the issues and actions identified in this appendix do not require TBDs or TBVs beyond those already identified.

D.1 Issue 1—Label Legibility

Future criteria must consider observation by both human and electronic means.

D.2 Issue 2— Disposal Container Lid Matching

The need for unique identification of the fabricated disposal container to a set of matched inner and outer lids needs to be investigated. If disposal containers will be matched to their lids, an identification system between the disposal container and its lids will be needed. The design criteria for such an identification will then need to be identified.

D.3 Issue 3— Handling Interface

The handling interface with the Disposal Container Handling System needs to be identified for empty disposal container handling, loaded disposal container handling, and lid handling.

D.4 Issue 4— Welding and Inspection Interface

The welding and inspection interface with the Disposal Container Handling System needs to be identified for inner and outer lid welding operations.

D.5 Issue 5— Inerting Interface and Operational Requirements

The filling of the container with an inert gas needs to be identified as an interface with the Disposal Container Handling System. Applicable disposal container requirements need to be determined.

D.6 Issue 6— Metric vs. Standard Units

Consistent display of both metric and standard units should be incorporated into criteria. Conversion leads to inconsistencies in the number of significant digits, accuracy, and summed values.

D.7 Issue 7— Identification as Disposal Container or Waste Package

A consistent method of identification of the waste form container as a “disposal container” or a “waste package” needs to be determined.

D.8 Issue 8— Disposal Container Materials of Construction

Criterion 1.2.1.4, which is a design constraint imposed by the “Monitored Geologic Repository Project Description Document,” will be moved to the Design Description section (Section 2) of this document in the next revision.

D.9 Issue 9— Waste Package Performance

Performance allocations for the waste packages to meet overall regulatory requirements need to be determined.

D.10 Issue 10— Waste Package Postclosure Criticality Requirements

Postclosure criticality requirements will be determined for a future revision.

APPENDIX E REFERENCES

This section provides a listing of references used in this SDD. References list the Accession number or Technical Information Catalog number at the end of the reference, where applicable.

“1995 ASME Boiler and Pressure Vessel Code.” The American Society of Mechanical Engineers. July 1, 1995. New York, New York: The American Society of Mechanical Engineers. TIC: 245287.

“American National Standard for Radioactive Materials - Special Lifting Devices for Shipping Containers Weighing 10000 Pounds (4500 kg) or More.” American National Standards Institute. ANSI N14.6-1993. 1993. New York, New York: American National Standards Institute. TIC: 236261.

“Characteristics of Potential Repository Wastes.” Oak Ridge National Laboratory. DOE/RW-0184-R1. Volume 1. July 1992. Washington, D.C.: U.S. Department of Energy, Office of Civilian Radioactive Waste Management. ACC: HQO.19920827.0001.

“Classification of the MGR Defense High-Level Waste Disposal Container System.” CRWMS M&O. ANL-DDC-SE-000001, Rev. 00. August 31, 1999. Las Vegas, Nevada: CRWMS M&O. ACC: MOL.19990928.0142.

“Criteria for Nuclear Criticality Safety Controls in Operations with Shielding and Confinement.” American Nuclear Society. ANSI/ANS-8.10-1983. 1983. La Grange Park, Illinois: American Nuclear Society. TIC: 205015.

“Criticality Safety Criteria for the Handling, Storage, and Transportation of LWR Fuel Outside Reactors.” American Nuclear Society. ANSI/ANS-8.17-1984. 1984. La Grange Park, Illinois: American Nuclear Society. TIC: 231625.

“Deficiency Report VAMO-98-D-132.” McCoy, J.K.; Wagner, L.W.; Clark, R.W.; Blaylock, J.; Hampton, C. September 25, 1998. Washington, D.C.: U.S. Department of Energy, Office of Civilian Radioactive Waste Management. ACC: MOL.19991029.0063.

“Design Analysis for the Defense High-Level Waste Disposal Container.” CRWMS M&O. ANL-DDC-ME-000001, Rev. 00. June 2000. Las Vegas, Nevada: CRWMS M&O. ACC: MOL.20000627.0254.

“Design Analysis for the Naval SNF Waste Package.” CRWMS M&O. ANL-VDC-ME-000001, Rev. 00. June 2000. Las Vegas, Nevada: CRWMS M&O. ACC: MOL.20000615.0029.

“Design Analysis for UCF Waste Packages.” CRWMS M&O. ANL-UDC-MD-000001, Rev. 00. May 2000. Las Vegas, Nevada: CRWMS M&O. ACC: MOL.20000526.0336.

“Design Criteria for an Independent Spent Fuel Storage Installation (Dry Type).” American Nuclear Society. ANSI/ANS-57.9-1992. 1992. La Grange Park, Illinois: American Nuclear Society. TIC: 3043.

“Disposal Criticality Analysis Methodology Topical Report.” Yucca Mountain Site Characterization Office. YMP/TR-004Q, Rev. 0. November 1998. Las Vegas, Nevada: Yucca Mountain Site Characterization Office. ACC: MOL.19990210.0236.

“DOE Spent Nuclear Fuel Grouping in Support of Criticality, DBE, TSPA-LA.” U.S. Department of Energy. DOE/SNF/REP-046, Rev. 0. May 2000. Idaho Falls, Idaho: U.S. Department of Energy, Idaho Operations Office. TIC: 248046.

“DOE Spent Nuclear Fuel Information in Support of TSPA-SR.” U.S. Department of Energy. DOE/SNF/REP-0047, Rev 0. 1999. Washington, D.C.: U.S. Department of Energy. TIC: 245482.

“Domestic Licensing of Production and Utilization Facilities.” Nuclear Regulatory Commission. 10 CFR 50. 1999. Washington, D.C.: U.S. Government Printing Office. Readily Available.

“Dose Rate Calculation for the DHLW/DOE SNF Codisposal Waste Package.” CRWMS M&O. CAL-DDC-NU-000001, Rev. 00. February 2000. Las Vegas, Nevada: CRWMS M&O. ACC: MOL.20000223.0505.

“Guidance on the Regulatory Requirements for Criticality Analysis of Fuel Storage at Light-Water Reactor Power Plants.” Memorandum from L. Kopp (NRC) to T. Collins (NRC), August 19, 1998, with attachment. Washington, D.C. ACC: HQO.19990520.0004.

“Incorporating Hanford 15 Foot (4.5 Meter) Canister Into Civilian Radioactive Waste Management System (CRWMS) Baseline.” Memorandum from W.J. Taylor to J. Williams. April 2, 1997. Richland, Washington: U. S. Department of Energy, Richland Operations Office. ACC: HQP.19970609.0014.

“Manager System Requirements/System Description Documents.” CRWMS M&O. RSO-RSO-99311.T. October 15, 1999. Las Vegas, Nevada: CRWMS M&O. ACC: MOL.19991019.0380.

“MGR Compliance Program Guidance Package for the Defense High-Level Waste (DHLW) Disposal Container.” CRWMS M&O. BBA000000-01717-5600-00002, Rev. 01, ICN 01. October 22, 1999. Las Vegas, Nevada: CRWMS M&O. ACC: MOL.19991105.0234.

“Mined Geologic Disposal System Functional Analysis Document.” CRWMS M&O. B00000000-01717-1708-00006, Rev. 01. September 26, 1996. Las Vegas, Nevada: CRWMS M&O. ACC: MOL.19970124.0397.

“Monitored Geologic Repository Project Description Document.” Bechtel SAIC Company. TDR-MGR-SE-000004, Rev. 02 ICN 02. June 2001. Las Vegas, Nevada: Bechtel SAIC Company. ACC: MOL.20010628.0224.

“Monitored Geologic Repository Requirements Document.” Yucca Mountain Site Characterization Office. YMP/CM-0025, Rev. 3, DCN 02. May 2000. Las Vegas, Nevada: Yucca Mountain Site Characterization Office. Submit to RPC. URN-376.

“N Reactor (U-metal) Fuel Characteristics for Disposal Criticality Analysis.” U.S. Department of Energy. DOE/SNF/REP-056, Rev. 0. May 2000. Idaho Falls, Idaho: Bechtel BWXT Idaho, LLC. TIC: 247956.

“Nuclear Criticality Control of Special Actinide Elements.” American Nuclear Society. ANSI/ANS-8.15-1981. 1981. La Grange Park, Illinois: American Nuclear Society. TIC: 231624.

“Nuclear Criticality Safety in Operations with Fissionable Materials Outside Reactors.” American Nuclear Society. ANSI/ANS-8.1-1998. 1998. La Grange Park, Illinois: American Nuclear Society. TIC: 242363.

“Nuclear Safety Criteria for Disposal Container System Description Documents.” CRWMS M&O. RSO-RSO-99333.Tb. July 19, 2000. Las Vegas, Nevada: CRWMS M&O. ACC: MOL.20000721.0001.

“Packaging and Transportation of Radioactive Material.” Nuclear Regulatory Commission. 10 CFR 71. Washington, D.C.: U.S. Government Printing Office. Readily Available.

“Physical Protection of Plants and Materials.” Nuclear Regulatory Commission. 10 CFR 73. Washington, D.C.: U.S. Government Printing Office. Readily Available.

“Preclosure Design Basis Events Related to Waste Packages.” CRWMS M&O. ANL-MGR-MD-000012, Rev 00. May 2000. Las Vegas, Nevada: CRWMS M&O. Submit to RPC URN-0396.

“Preliminary Design Specification for Department of Energy Standardized Spent Nuclear Fuel Canisters.” Volume I, Design Specification. U.S. Department of Energy. DOE/SNF/REP-011, Rev. 3. 1999. Washington, D.C.: U.S. Department of Energy, Office of Spent Fuel Management and Special Projects. TIC: 246602.

“Quality Assurance Requirements and Description.” U.S. Department of Energy. DOE/RW-0333P, Rev. 10. April 2000. Washington, D.C.: U.S. Department of Energy, Office of Civilian Radioactive Waste Management. ACC: MOL.20000427.0422.

“Residual Stress Minimization of Waste Packages from Induction Annealing.” CRWMS M&O. CAL-UDC-ME-000004, Rev. 00. February 2000. Las Vegas, Nevada: CRWMS M&O. ACC: MOL.20000221.0713.

“Revised Interim Guidance Pending Issuance of New U.S. Nuclear Regulatory Commission (NRC) Regulations (Revision 01, July 22, 1999), for Yucca Mountain, Nevada.” U.S. Department of Energy. OL&RC:SB-1714. September 3, 1999. North Las Vegas, Nevada: U.S. Department of Energy, Office of Civilian Radioactive Waste Management, Yucca Mountain Site Characterization Office. ACC: MOL.19990910.0079.

“Standards for Protection Against Radiation.” Nuclear Regulatory Commission. 10 CFR 20. 1999. Washington, D.C.: U.S. Government Printing Office. Readily Available.

“Technical Reports.” U.S. Department of Energy, Office of Civilian Radioactive Waste Management. AP-3.11Q, Rev. 2. April 3, 2001. Las Vegas, Nevada: U.S. Department of Energy, Office of Civilian Radioactive Waste Management. ACC: MOL.20010405.0010.

“Technical Work Plan for: Waste Package Design Description for SR.” Bechtel SAIC Company. TWP-EBS-MD-000003 REV 01. Las Vegas, Nevada: Bechtel SAIC Company. ACC: MOL.20010629.0074.

“Tensile Stresses Developing in an Outer Shell of a Waste Package Mounted on an Emplacement Pallet.” CRWMS M&O. CAL-EBS-ME-000004, Rev. 00. January 2000. Las Vegas, Nevada: CRWMS M&O. ACC: MOL.20000207.0715.

“Thermal Evaluation of the TRIGA Codisposal Waste Package.” CRWMS M&O. BBAA00000-01717-0210-00022, Rev. 00. July 1999. Las Vegas, Nevada: CRWMS M&O. ACC: MOL.19990712.0195.

“TRIGA Fuel Phase I and II Criticality Calculation.” CRWMS M&O. CAL-MGR-NU-000001, Rev. 00. November 1999. Las Vegas, Nevada: CRWMS M&O. ACC: MOL.19991209.0195.

“Uncanistered Spent Nuclear Fuel Disposal Container System Description Document.” CRWMS M&O. SDD-UDC-SE-000001, Rev. 00. November 30, 1999. Las Vegas, Nevada: CRWMS M&O. ACC: MOL.19991217.0512.

“U.S. Department of Energy Spent Nuclear Fuel to the Monitored Geologic Repository for Mechanical and Envelope Interfaces.” Volume 1 of “Integrated Interface Control Document.” U.S. Department of Energy. DOE/RW-0511, Rev. 0. March 1999. Las Vegas, Nevada: U.S. Department of Energy, Office of Civilian Radioactive Waste Management. ACC: MOL.19990428.0236.

“Waste Acceptance System Requirements Document.” DOE/RW-0351, Rev. 03. April 1999. Washington, D.C.: U.S. Department of Energy, Office of Civilian Radioactive Waste Management. ACC: HQO.19990226.0001.

“Waste Package Design Sensitivity Report.” Bechtel SAIC Company. TDR-EBS-MD-000008, Rev. 01. March 2001. Las Vegas, Nevada: Bechtel SAIC Company. ACC: MOL.20010313.0506.

“Waste Package Lifting Calculation.” CRWMS M&O. CAL-EBS-ME-000007, Rev. 01. May 2000. Las Vegas, Nevada: CRWMS M&O. ACC: MOL.20000524.0429.

“Waste Package Degradation Process Model Report.” CRWMS M&O. TDR-WIS-MD-000002, Rev. 00 ICN 01. June 2000. Las Vegas, Nevada: CRWMS M&O. ACC: MOL.20000717.0005.

“Waste Package Neutron Absorber, Thermal Shunt, and Fill Gas Selection Report.” CRWMS M&O. B00000000-01717-2200-00227, Rev. 00. January 2000. Las Vegas, Nevada: CRWMS M&O. ACC: MOL.20000209.0301.

“Waste Package Size Study Report.” CRWMS M&O. B00000000-01717-5705-00079, Rev. 01. July 20, 1998. Las Vegas, Nevada: CRWMS M&O. ACC: MOL.19981020.0108.

“Waste Quantity, Mix and Throughput Study Report.” CRWMS M&O. B00000000-01717-5705-00059, Rev. 01. August 15, 1997. Las Vegas, Nevada: CRWMS M&O. ACC: MOL.19971210.0628.