

AN INVESTIGATION OF THE MECHANISM OF IGA/SCC OF ALLOY 600
IN CORROSION ACCELERATING HEATED CREVICE ENVIRONMENTS

NUCLEAR ENERGY RESEARCH INITIATIVE (NERI) PROGRAM
DE-FG03-99SF21921

TECHNICAL PROGRESS REPORT

Principal Investigator:
Dr. Jesse Lumsden
Rockwell Science Center
1049 Camino dos Rios
Thousand Oaks, CA 91360
E Mail: jblumsden@rsc.rockwell.com

This program focuses on understanding mechanisms causing corrosion damage to steam generator tubes in a pressurized water reactor (PWR). The crevice formed by the tube/tube support plate (T/TSP) intersection in a PWR steam generator is a concentration site for nonvolatile impurities (referred to as hideout) in the steam generator water. The restricted mass transport in the small crevice volume prevents the species, which concentrate during the generation of steam, from quickly dispersing into the bulk water. The concentrated solutions in crevices have been a contributing cause of several forms of corrosion of steam generator tubes including intergranular attack/stress corrosion cracking (IGA/SCC), pitting, and wastage.

The present strategy for mitigating IGA/SCC aims at controlling the crevice chemistry. This is based on the assumption that crack initiation and propagation rates depend on pH and the electrochemical potential (ECP). Laboratory data, using static autoclaves, show that IGA/SCC crack growth rates reach a minimum at pH's between 5 and 9 under electrochemically reducing conditions. Some plants are injecting Na and Cl ions into the feedwater to adjust the crevice pH. There are several uncertainties in this approach. Since measurements of crevice chemistry and electrochemical potential (ECP) cannot be made in an operating steam generator, estimates are made using computer codes based on

DISCLAIMER

This report was prepared as an account of work sponsored by an agency of the United States Government. Neither the United States Government nor any agency thereof, nor any of their employees, make any warranty, express or implied, or assumes any legal liability or responsibility for the accuracy, completeness, or usefulness of any information, apparatus, product, or process disclosed, or represents that its use would not infringe privately owned rights. Reference herein to any specific commercial product, process, or service by trade name, trademark, manufacturer, or otherwise does not necessarily constitute or imply its endorsement, recommendation, or favoring by the United States Government or any agency thereof. The views and opinions of authors expressed herein do not necessarily state or reflect those of the United States Government or any agency thereof.

DISCLAIMER

Portions of this document may be illegible in electronic image products. Images are produced from the best available original document.

hypothesized processes believed to occur in crevices. Moreover, laboratory IGA/SCC data were obtained in static autoclaves using simulated crevice solutions. The IGA/SCC mechanism may be different under heat flux conditions, during which steam is being generated. Crevice chemistries are complex and pH may not be the important factor or the only important factor.

The objective of this program is to develop an understanding of the corrosion accelerating mechanisms, particularly IGA/SCC, in steam generator crevices. The important variables will be identified, including the relationship between bulk water chemistry and corrosion accelerating chemistries in a crevice. The approach will use an instrumented heated crevice, which is a replica of a PWR steam generator tube/TSP crevice. With the system operating at simulated steam generator thermal conditions, measurements can be made of the chemical, electrochemical, and thermal conditions in the crevice. Damage to the tube due to IGA/SCC and other corrosion processes will be monitored using electrochemical noise. Task 1: Modification of Heated Crevice for SCC and Electrochemical Noise Measurements.

1. Task Status.

The engineering drawings of the tube design were completed. Figure 1 is the drawing for the heated crevice showing the complete autoclave - tube assembly. The design allows the Alloy 600 steam generator tube to be pressurized to 2700 psi while at simulated PWR steam generator conditions. The tube is heated electrically by an internal cartridge heater. Eight thermocouples are brazed on the ID of the tube at different elevations within the crevice. The whole assembly is electrically isolated from a Alloy 600 ring forming a crevice 2.5 cm long and having a 0.3 mm gap. A drawing of the tube is shown in Figure 2, which indicates the high pressure fitting for pressurizing the tube, the feed throughs for the thermocouple leads and the flange for attaching the tube assembly to the autoclave. A prototype of the tube is nearing completion for testing. When the design is validated construction will begin on the entire heated crevice system.

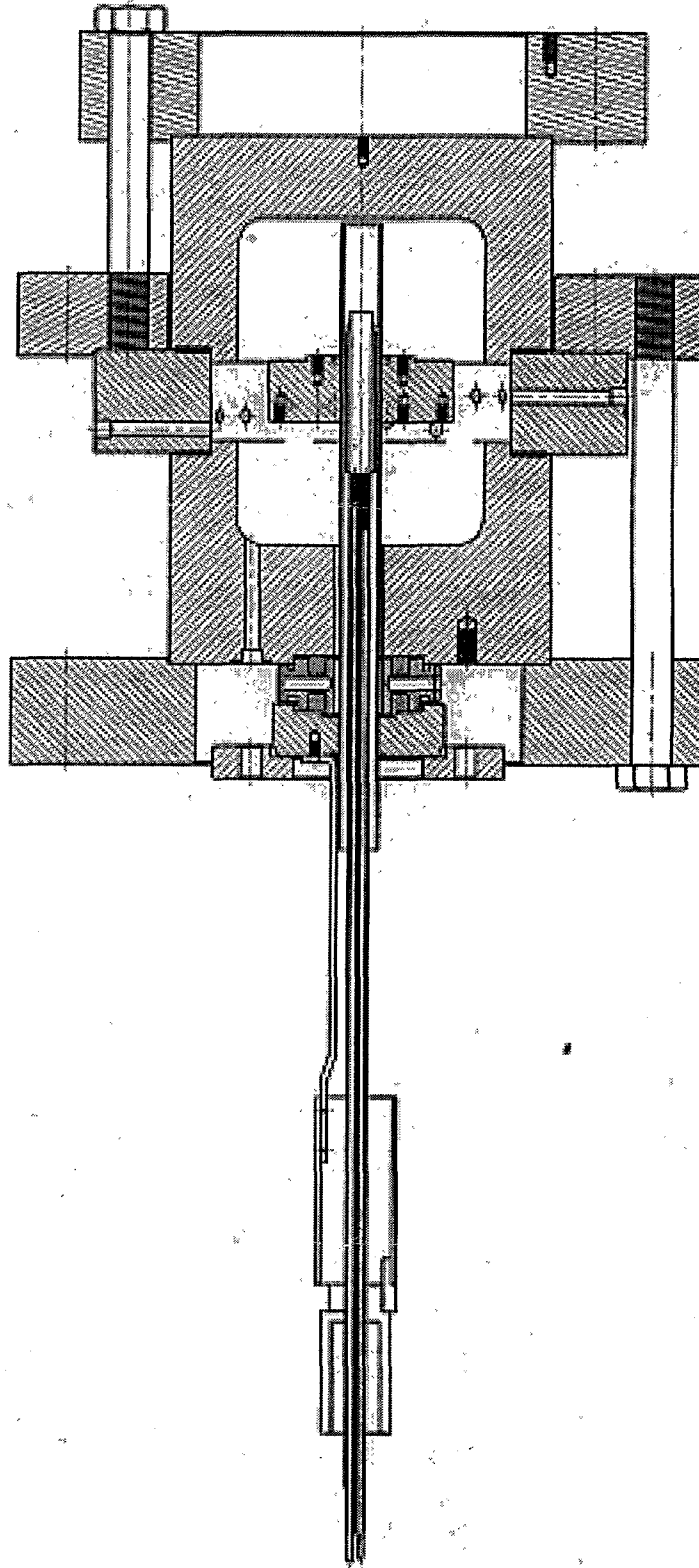

Figure 1. The drawing of the heated crevice assembly.

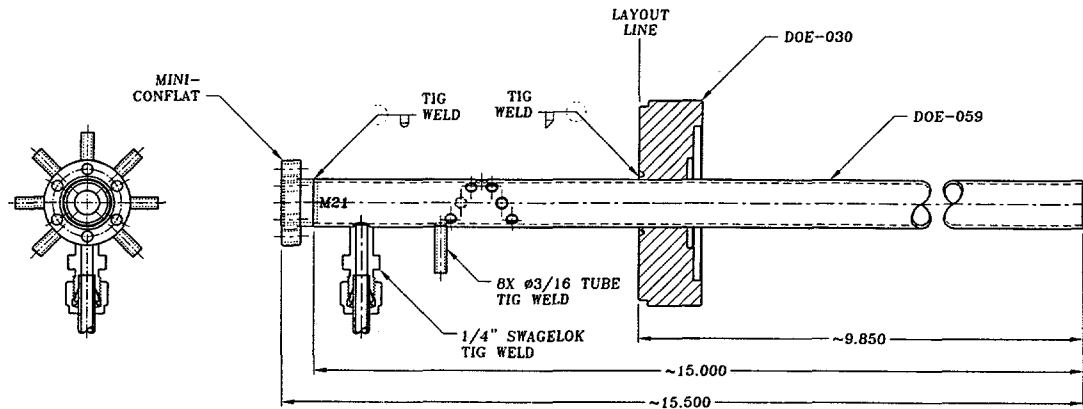

Figure 2. The Drawing the Alloy 600 tube the high pressure fitting and the thermocouple feed throughs.

2. Issues/Concerns.

None

Task 2: Evaluation of Electrochemical Noise

1. Task Status.

The hardware and software for electrochemical noise measurements has been tested successfully for a simple corroding system at room temperature. Further testing can be performed at the completion of Task 1.

2. Issues/concerns

None

**An Investigation of the Mechanism of IGA/SCC of Alloy 600 in Corrosion
Accelerating Heated Crevice Environments
DE-FG03-99SF21921**

5. SPECIAL INSTRUCTIONS :

1. The attached Report Distribution List specifies the various reports/plans required, the address codes to which they must be delivered, and the total number of copies required. The list of address codes shows both the actual mailing address and the number of copies to be delivered to each addressee.
2. Technical Progress Reports shall provide a narrative summary of items of interest and shall incorporate a marked up version of the milestone deliverable plan, and a listing of tasks/milestones with the planned due date and actual completion date. See the attached example for format.
3. The Topical Reports and due dates are as follows:
 - A. Topical report on results for Modification of Heated Crevice: due 9/30/00.
 - B. Progress Report on Phase 1 Activities: due 9/30/00.
 - C. Topical report on results for Baseline SCC Measurements: due 9/30/01.
 - D. Progress Report for Phase 2 Activities: due 9/30/01.
 - E. Topical report on results for Evaluation of Electrochemical Noise: due 9/30/02.
 - F. Topical report on results for Effects of pH: due 9/30/02.
 - G. Topical report on results for Complex Environments: due 9/30/02.
 - H. Topical report on results for Model Calculations: due 9/30/02.
 - I. Final Technical Report: due 9/30/02
4. All technical reports must be submitted as instructed and accompanied by two copies of DOE F241.1 "Announcement of U.S. Department of Energy (DOE) Scientific and Technical Information (STI)".

REPORTING REQUIREMENTS CHECKLIST

**An Investigation of the Mechanism of IGA/SCC of Alloy of 600 Corrosion
Accelerating Heated Crevice Environments
DE-FG03-99SF21921**

5. SPECIAL INSTRUCTIONS (continued)

Reports Distribution Checklist:

<u>Report/Plan</u>	<u>No. of Copies</u>	<u>Address</u>
1. Federal Assistance Milestone Plan	1, 1, 1	A, B, C
2. Financial Status Report (SF-269 or 269A)	1	A
3. Notice of Energy R & D Project	1, 1	A, D
4. Technical Progress Report	1, 1, 1, 1	A, B, C, D
5. Topical Report	1, 1, 1, 1	A, B, C, D
6. Final Technical Report	1, 1, 1, 1	A, B, C, D

**An Investigation of the Mechanism of IGA/SCC of Alloy 600 in Corrosion
Accelerating Heated Crevice Environments
DE-FG03-99SF21921**

5. SPECIAL INSTRUCTIONS (continued)

Reports Distribution Checklist:

<u>Report/Plan</u>	<u>No. of Copies</u>	<u>Address</u>
1. Federal Assistance Milestone Plan	1,1,1	A,B,C
2. Financial Status Report (SF-269 or 269A)	1	A
3. Notice of Energy R&D Project	1,1	A,D
4. Technical Progress Report	1,1,1,1	A,B,C,D
5. Topical Report	1,1,1,1	A,B,C,D
6. Final Technical Report	1,1,1,1	A,B,C,D

A.

**An Investigation of the Mechanism of IGA/SCC of Alloy 600 in Corrosion
Accelerating Heated Crevice Environments
DE-FG03-99SF21921**

5. SPECIAL INSTRUCTIONS (continued)

List of Addresses

- A. U. S. Department of Energy
Oakland Operations Office
1301 Clay Street
Oakland, CA 94612
Attn:

- B. U. S. Department of Energy
Oakland Operations Office
1301 Clay Street
Oakland, CA 94612
Attn: Salma El-Safwany, NSPD

- C. U. S. Department of Energy
19901 Germantown Rd.
Germantown, MD 20874
Attn: Frank Ross, NE-20

- D. U.S. Department of Energy
Office of Scientific and Technical Information
Technical Information Center.
P.O. Box 62
Oak Ridge, TN 37831