



STANFORD RESEARCH INSTITUTE
Menlo Park, California 94025 · U.S.A.

ERDA 76-129/4

May 1977

**SYNTHETIC LIQUID FUELS DEVELOPMENT:
ASSESSMENT OF CRITICAL FACTORS**

**VOLUME IV ENERGY/ECONOMIC COMPARISON
OF COAL-BASED AUTOMOTIVE
ENERGY SUPPLY SYSTEMS**

By: ROBERT V. STEELE, KISHANDUTT J. SHARMA, and
EDWARD M. DICKSON

Prepared for:

TRANSPORTATION ENERGY CONSERVATION DIVISION
OFFICE OF CONSERVATION
U.S. ENERGY RESEARCH AND DEVELOPMENT ADMINISTRATION
WASHINGTON, D.C. 20545

SRI Project EGU-4810

CENTER FOR RESOURCE AND ENVIRONMENTAL SYSTEMS STUDIES

Report No. 15

NOTICE

This report was prepared as an account of work sponsored by the United States Government. Neither the United States nor the United States Energy Research and Development Administration, nor any of their employees, nor any of their contractors, subcontractors, or their employees, makes any warranty, express or implied, or assumes any legal liability or responsibility for the accuracy, completeness or usefulness of any information, apparatus, product or process disclosed, or represents that its use would not infringe privately owned rights.

MASTER

DISTRIBUTION OF THIS DOCUMENT IS UNLIMITED

SM

DISCLAIMER

This report was prepared as an account of work sponsored by an agency of the United States Government. Neither the United States Government nor any agency thereof, nor any of their employees, makes any warranty, express or implied, or assumes any legal liability or responsibility for the accuracy, completeness, or usefulness of any information, apparatus, product, or process disclosed, or represents that its use would not infringe privately owned rights. Reference herein to any specific commercial product, process, or service by trade name, trademark, manufacturer, or otherwise does not necessarily constitute or imply its endorsement, recommendation, or favoring by the United States Government or any agency thereof. The views and opinions of authors expressed herein do not necessarily state or reflect those of the United States Government or any agency thereof.

DISCLAIMER

Portions of this document may be illegible in electronic image products. Images are produced from the best available original document.

SYNTHETIC LIQUID FUELS DEVELOPMENT
ASSESSMENT OF CRITICAL FACTORS — VOLUME IV

ENERGY/ECONOMIC COMPARISON
OF COAL-BASED AUTOMOTIVE
ENERGY SUPPLY SYSTEMS

EXECUTIVE SUMMARY

Is energy analysis needed to select energy supply choices that conserve resources?

As the nation strives to reduce its dependence on foreign petroleum sources, technologies for converting coal and oil shale to liquid and gaseous fuels become increasingly important. These new synfuel systems must be analyzed for their economic and technical feasibility, environmental impact, and socioeconomic effects. But an additional factor — the analysis of energy resources required to produce and deliver useful forms of energy — may also prove important because the nation must choose judiciously among alternative supply options to conserve resources.

Traditional economists say “No.” Energy analysts say “Yes.”

The relative merits of energy analysis versus traditional economic analysis have been debated at length in recent years. Some economists assert that energy analysis adds no new information to that already contained in economic analysis. Some energy analysts, on the other hand, claim that the explicit consideration of energy flows is necessary for a complete understanding of the implications of energy supply and use. Furthermore, these energy analysts argue that the market has not been able to serve its appropriate role as an allocator of energy resources because of government regulation and the influence of the OPEC cartel. Therefore, so the argument goes, energy analysis provides a valuable service in illuminating the effect that the many energy supply and conservation choices facing the nation will have on energy resource consumption.

One way to find out is to compare the two approaches

The objective of the study reported here was to compare the choices that result from a traditional economic analysis of energy supply systems with those obtained from an energy analysis to see if similar or divergent options emerge. This issue has particular significance to those who must make decisions in the field of energy conservation because it is desirable that those options that are the most energy conservative also be low cost. Energy conservative but high cost options present difficult tradeoffs.

Six coal-based automotive energy forms were analyzed for cost and energy consumption.

Our comparison of options was focused on energy supply systems that could provide automotive energy. Six coal-based energy forms (Figure I) — gasoline refined from synthetic crude oil (syncrude), methanol, gasoline produced by Fischer-Tropsch synthesis, liquid hydrogen, liquid methane, and electricity — were analyzed in terms of cost and energy consumption.

The six were:

- Syncrude/gasoline**
- Methanol**
- Fischer-Tropsch gasoline**
- Liquid hydrogen**
- Liquid methane**
- Electricity**

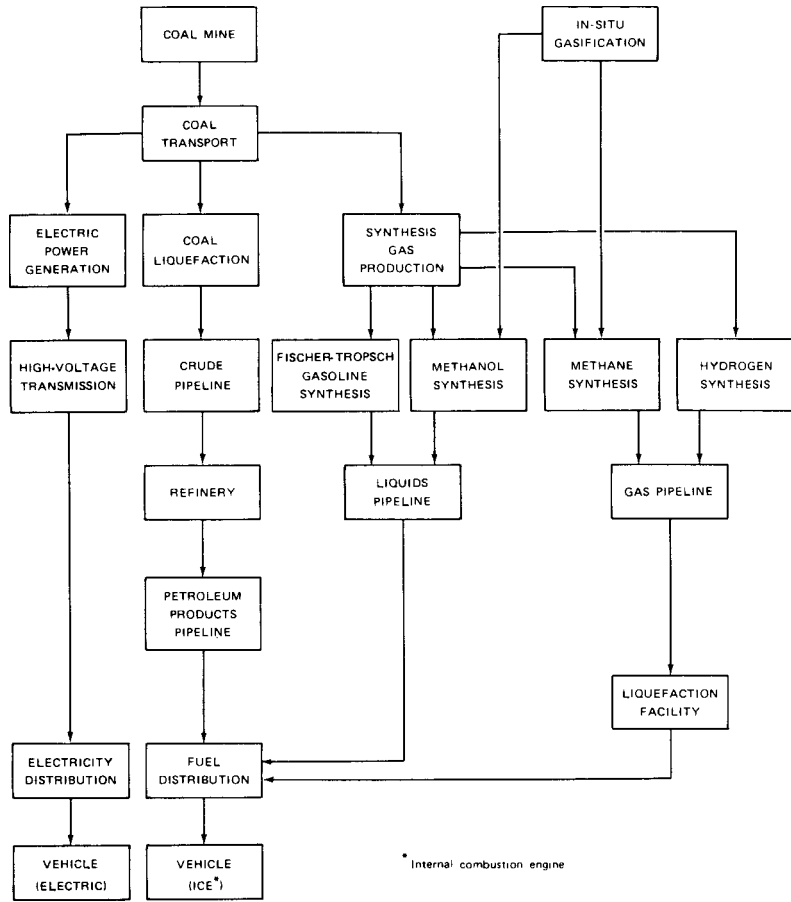

I COAL-BASED AUTOMOTIVE ENERGY SUPPLY SYSTEMS

Using only coal-based energy forms promoted consistency in the comparison of options. The five synthetic liquid fuels could be used in conventional or modified internal combustion engines, while electricity was assumed for use in powering electric cars that employ an advanced battery such as lithium-sulfur. Included in the energy supply systems were coal mining, coal transport, coal conversion, product transport, refining (for syncrude only), and product distribution.

A range of costs for each energy supply system was determined

The cost analysis was based on the Coal Resource Depletion Model presented in a related study.* The output of this model provides coal conversion costs for plants in various regions of the country. Additional costs are assigned to product transport and distribution for all possible market areas for each conversion plant location. Thus, a range of costs representing the effects of varying coal types, conversion plant locations, and market locations was determined for each energy supply option. The percentage differences between minimum and maximum costs of delivered energy for the six options, as influenced by the factors cited above, are as follows: syncrude/gasoline, 24%; Fischer-Tropsch gasoline, 9%; methanol, 10%; liquid hydrogen, 16%; liquid methane, 14%; and electricity, 43%.

*E. M. Dickson, et al., "Synthetic Liquid Fuels Development: Assessment of Critical Factors — Volume III, Regionalized Industry, Social Impact, Coal Resource Depletion," Division of Transportation Energy Conservation, U.S. Energy Research and Development Administration, ERDA 76-129/3 (1977).

Results showed that syn-crude/gasoline is the cheapest option

But, for propelling an automobile, electricity is cheapest

Energy consumed to produce each energy form was then calculated

Results showed that Fischer-Tropsch gasoline consumes the most energy, with electricity next highest, and syn-crude/gasoline the lowest

But, again, electricity is lowest in energy use when automotive efficiency is considered

High-cost automotive energy system components are also high energy users

The results of the cost analysis showed that syncrude/gasoline is the least costly option, followed by methanol, methane, Fischer-Tropsch gasoline, hydrogen, and electricity. In addition, the costs of methane and methanol produced through in-situ gasification of coal were analyzed and found to be lower than all options except syncrude/gasoline.

When the efficiency of converting various fuels to motive power in an automobile is considered, the relative cost picture changes. Using nominal internal combustion engine efficiencies (subcompact car) for the five liquid fuels, and the electricity consumption for an advanced electric car, we found that electricity is the lowest cost option on a cents per mile basis, followed by syncrude/gasoline, methanol, methane, hydrogen, and Fischer-Tropsch gasoline.*

Energy consumption of the six energy supply systems was analyzed in a manner analogous to the cost analysis. Energy accounting techniques described in our previous work† were used to assign an ancillary energy requirement to each component in the energy supply systems. The energy "cost" of each component was then computed as the sum of the ancillary energy requirement and the energy loss from each component, as determined by its overall energy efficiency. Using the same model approach employed in the cost calculations, the component energy consumption figures were added to obtain the total energy consumed in delivering 10^6 Btu of each energy form. As in the cost calculations, the variations in energy consumption among coal types, conversion plant locations, and market locations were determined.

The results of the energy analysis showed that the energy consumed (converted to waste heat or nonfuel products) in delivering 10^6 Btu of automotive fuel or electricity can range from a low of 0.8×10^6 Btu for syncrude/gasoline to a high of 2.5×10^6 Btu for Fischer-Tropsch gasoline. Between these two extremes lie methane, methanol, hydrogen, and electricity — in order of increasing energy consumption. Methane and methanol derived from in-situ gasification of coal are slightly higher than syncrude/gasoline.

As in the cost analysis, the consideration of automotive energy efficiency results in a different picture for the relative attractiveness of each option in terms of energy consumption. Due to the high expected efficiency of advanced batteries, the electricity option has the lowest total energy requirement — 5000 Btu/mi. Fischer-Tropsch gasoline has by far the highest at 14,300 Btu/mi. Methanol, methane, and hydrogen are in the 9000 to 10,000 Btu/mi range, while syncrude/gasoline is 7500 Btu/mi — 50% higher than electricity.

In comparing the cost and energy consumption figures for the various automotive energy options, certain parallels are evident. Those system components that have the highest costs also require high

*To account for changes resulting from rapidly escalating costs, as well as errors due to the speculative nature of many of the cost estimates, a sensitivity analysis is given for each energy supply option (Appendix C).

†E. M. Dickson, et al., "Synthetic Liquid Fuels Development: Assessment of Critical Factors," U.S. Energy Research and Development Administration, ERDA 76-129/2 (1976).

levels of energy consumption. This is generally due to the severity of the processing conditions required to convert one energy form (e.g., coal) to another (e.g., methanol). These conditions require the use of capital-intensive equipment as well as the consumption of large amounts of energy. For some components that have relatively high costs but low energy requirements (e.g., fuel distribution), the costs are due to the many handling and transfer requirements, which are often labor-intensive and can also involve expensive equipment. However, such handling and transfer steps do not consume large amounts of energy.

These results are peculiar to capital- and energy-intensive systems

Overall, the capital- and energy-intensive energy conversion processes dominate the systems examined. Consequently, a comparison of cost with energy consumption for all of the energy forms considered showed a definite trend — increasing costs imply increasing energy consumption (Figure II).

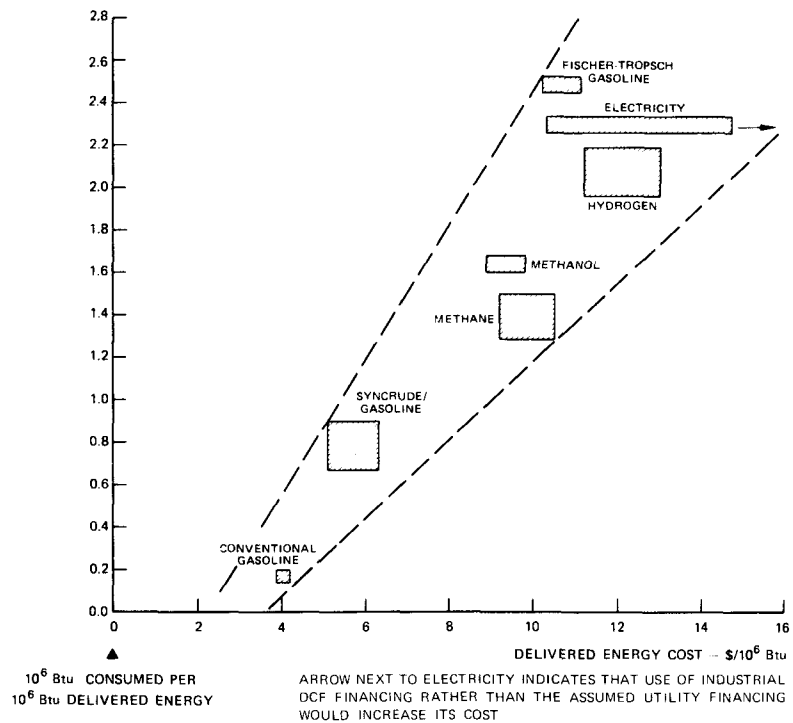

II ENERGY CONSUMPTION VS COST FOR AUTOMOTIVE ENERGY SUPPLY SYSTEMS

Thus, decision makers concerned with promoting energy conservative supply options can feel confident that they are also promoting the least costly energy conversion options.

Less energy- and capital-intensive energy supply systems may show a different trend

However, we caution against extrapolating these results to other systems because systems that do not have the same kinds of capital- and energy-intensive components as those considered here may exhibit different trends.

PREFACE

The analysis reported in this volume is a continuation of an SRI study concerned with the impacts that would attend the deployment of a large-scale synthetic fuels industry. The study was begun under the sponsorship of the Environmental Protection Agency and continued under the sponsorship of the Energy Research and Development Administration.* Throughout, the lead project officer, first at EPA, then at ERDA, has been Mr. F. Jerome Hinkle. The SRI project leader has been Dr. Edward M. Dickson.

The study team responsible for this volume consisted of Drs. Robert V. Steele and Kishandutt J. Sharma.

*The first two volumes in this series were originally published by EPA under the title "Impacts of Synthetic Liquid Fuel Development--Automotive Market," (EPA-600/7-76-004 a,b). ERDA reissued the same report under the title, "Synthetic Liquid Fuels Development: Assessment of Critical Factors," (ERDA 76-129/1 and 76-129/2).

CONTENTS

EXECUTIVE SUMMARY	i
PREFACE	v
LIST OF ILLUSTRATIONS	xi
LIST OF TABLES	xiii
1 INTRODUCTION	1- 1
A. The Concept of Energy Analysis	1- 1
B. Comparisons with Economic Analysis	1- 2
C. The Utility of Energy Analysis	1- 3
References	1- 5
2 OBJECTIVES OF THE STUDY	2- 1
A. Examination of Coal-Based Systems	2- 1
B. Limitations of Idealized Systems	2- 1
3 ECONOMIC ANALYSIS	3- 1
A. Objectives and Background	3- 1
B. Major Assumptions and Their Implications	3- 2
1. Costs Derived from the Coal Depletion Model	3- 2
2. Advanced Technology and Its Costs	3- 2
3. Variations in Location	3- 4
4. Use of Historical Costs	3- 4
5. Vehicle Efficiencies	3- 4
C. Approach	3- 5
1. Component Cost Computation	3- 5
2. Computer Program	3- 8
D. COMPUTATIONAL RESULTS	3- 8
1. Comparison of the Options	3- 9
2. Impact of Changing Vehicle Efficiencies	3-11
3. Costs of In-Situ Gasification Options	3-11
E. Sensitivity to the Regional Differences	3-13
F. Sensitivity to the Variations in Cost Parameters	3-15
References	3-18

4	ENERGY ANALYSIS	4- 1
	A. Methodology	4- 1
	1. Process Analysis	4- 1
	2. Input-Output Analysis	4- 3
	3. Odum's Approach	4- 4
	4. Net Energy Analysis--A Practical Approach	4- 6
	B. Calculations on System Components	4- 7
	C. Total System Energy Requirements	4- 9
	D. Results	4-10
	1. Total Energy Consumption	4-10
	2. Automotive Efficiency Effects	4-17
	References	4-20
5	COMPARISON OF ENERGY AND ECONOMIC RESULTS	5- 1
	A. Summary of Results	5- 1
	B. Comparison of Costs and Energy Consumption	5-11
	C. Conclusions	5-13
APPENDIX A--AN ALTERNATIVE ENERGY CONSUMPTION ANALYSIS		
	OF SYNTHETIC LIQUID FUELS	A- 1
	A. Introduction	A- 1
	B. Energy Flows in the U.S. Petroleum System--1973	A- 2
	C. Use of Energy Resources in Synthetic Liquid Fuel Production	A- 4
	D. Incremental Transportation Energy Requirements for Use of Synthetic Fuels	A- 6
	E. Conclusions	A-11
	References	A-13
APPENDIX B--ENERGY AND ECONOMIC EVALUATION OF ELECTRIC		
	VEHICLES AND SYNFUEL-POWERED VEHICLES	B- 1
	A. Costs of Automotive Transportation	B- 1
	1. Life Cycle Costs of Alternatives	B- 1
	2. Analysis of Cost Inputs	B- 5
	B. Energy Efficiency	B- 7
	1. Method of Calculating Energy Resource Consumption	B- 7
	2. Comparison of Alternatives	B- 8
	References	B-14

APPENDIX C--SENSITIVITIES OF DELIVERED AUTOMOTIVE ENERGY COSTS TO CHANGES IN THE COSTS OF SYSTEM COMPONENTS	C- 1
APPENDIX D--CALCULATIONS OF ENERGY REQUIREMENTS FOR COMPONENTS OF AUTOMOTIVE ENERGY SUPPLY SYSTEMS	D- 1
References	D-12

ILLUSTRATIONS

2-1	Coal-Based Automotive Energy Supply Systems	2- 2
3-1	Components of the Syncrude/Gasoline System	3- 3
3-2	Flow Chart for Automotive Energy Cost Calculations	3- 6
3-3	Comparison of Automotive Energy Costs	3-10
3-4	Variation of Automotive Energy Cost with Vehicle Propulsion Energy Requirements	3-12
3-5	Comparison of Delivered Methane and Methanol Costs Using In Situ and Above-Ground Coal Gasification	3-14
3-6	Summary of Sensitivity Analysis	3-17
4-1a	Energy Consumption by Synthetic Fuel Systems	4-11
4-1b	Energy Consumption by Synthetic Fuel Systems	4-12
4-1c	Energy Consumption by Synthetic Fuel Systems	4-13
4-2	Energy Consumption by Automotive Energy Supply Systems	4-16
4-3	Total Energy Requirements for Automotive Transportation	4-18
5-1	Energy-Economic Comparison: Syncrude/Gasoline	5- 2
5-2	Energy-Economic Comparison: Fischer-Tropsch Gasoline	5- 3
5-3	Energy-Economic Comparison: Methanol	5- 4
5-4	Energy-Economic Comparison: Methane	5- 5
5-5	Energy-Economic Comparison: Hydrogen	5- 6
5-6	Energy-Economic Comparison: Electricity	5- 7
5-7	Energy-Economic Comparison: In Situ Methane	5- 8
5-8	Energy-Economic Comparison: In Situ Methanol	5- 9
5-9	Energy Consumption vs. Cost for Automotive Energy Supply Systems	5-12
A-1	Energy Flows in the U.S. Petroleum Supply System in 1973	A- 3
B-1	Energy Consumption of Coal-To-Synfuel Vehicle System	B- 9
B-2	Energy Consumption of Coal-To-Electric Vehicle System	B-10
B-3	Total Energy Comparison of Electric and Synthetic Fuel-Powered Vehicles	B-12

C-1	Cost Sensitivity: Syncrude Plant in Beaumont, Texas Using Appalachian Underground Coal	C-2
C-2	Cost Sensitivity: Methane Plant in New Orleans, Louisiana Using Illinois Surface Coal	C-4
C-3	Cost Sensitivity: Methanol Plant in Galveston, Texas Using Appalachian Surface Coal	C-5
C-4	Cost Sensitivity: Fischer-Tropsch Gasoline Plant in Galveston, Texas Using Appalachian Surface Coal	C-6
C-5	Cost Sensitivity: Hydrogen Plant in Galveston, Texas Using Appalachian Surface Coal	C-7
C-6	Cost Sensitivity: Coal Fired Power Plant in Boston, Massachusetts Using Appalachian Surface Coal	C-9

TABLES

3-1	Cost Sensitivity to Regional Differences	3-16
4-1	Energy Requirements for Coal-To-Automotive Fuels System Components	4- 8
4-2	Conversion Plant Locations and Coal Sources for the Minimum and Maximum Energy Consumption Cases	4-14
A-1	Total Consumption of Energy Required to Provide Fuel for One Vehicle-Mile of Automotive Transportation in 1973	A- 5
A-2	Total Energy Resource Commitment Required to Produce 1 Btu of Synthetic Liquid Fuel	A- 7
A-3a	Incremental Energy Required to Replace a Fraction, F, of Automotive Fuel Demand with Synthetic Liquids Derived from Coal and Oil Shale--Base Year 1973	A- 9
A-3b	Incremental Energy Required to Replace a Fraction, F, of Automotive Fuel Demand with Synthetic Liquids Derived from Coal and Oil Shale--Base Year 1973	A-10
B-1	Operating Costs for Synthetic-Fueled Subcompact Car	B- 2
B-2	Operating Costs for Electric Car with Advanced Battery	B- 3
B-3	Comparison of Automobile Transportation Costs	B- 4
B-4	Contributors to Synfuel and Electric Energy Costs	B- 6

Chapter 1

INTRODUCTION

A. The Concept of Energy Analysis

As the nation strives to reduce its dependence on foreign petroleum sources, technologies for converting coal and oil shale to liquid and gaseous fuels become increasingly important. Our study in Volume II of this series, "Synthetic Liquid Fuels Development: Assessment of Critical Factors,"¹ was addressed to policy makers investigating alternative pathways to synthetic fuel (synfuel) development. The study detailed the anticipated impacts of the new, large-scale industry required for such development.

These new synfuel systems must be examined for multiple factors: economic and technical feasibility, environmental impact, socioeconomic effect, and capital availability. But it is an additional factor--these systems' effective use of energy resources--that primarily concerns us here. The analytical tool that we have found useful for determining the energy resources required to produce and deliver a given quantity of synfuel is energy analysis, sometimes called net energy analysis or energy accounting.

Energy analysis applied to the production of fuels determines the yield of useful energy of any energy-conversion process after extraction, processing, transportation, and distribution of the final product have taken place. The "energy cost" derived by this analysis represents the total energy that must be consumed to deliver a unit of energy product such as gasoline. Thus, energy analysis accounts for all energy flows in a single resource-to-fuel system. It also allows the comparison of different energy systems that provide the same end-use to determine their relative energy resource intensities.

B. Comparisons with Economic Analysis

Many economists assert that explicit consideration of energy inputs into energy supply systems does not appreciably enhance traditional economic analysis. This would indeed be the case if energy prices reflected the true costs, including environmental and social costs, of producing and delivering energy. Such energy pricing, coupled with a free market, could then provide optimal allocation of energy resources.

In practice, such conditions do not hold. The government regulates domestic energy markets, and the OPEC cartel arbitrarily maintains the petroleum prices that influence those markets. Thus, real-world energy prices are determined by other factors than those that would yield optimal allocation of resources.

Economic analysis must recognize the role of energy consumption because the price of raw energy, working through a feedback mechanism, is a primary force in driving inflation. As raw energy prices increase, the cost of delivered energy in the form of fuels and electricity increases. As a result, the costs of goods and services, which are all energy-dependent to some extent, increase, in turn raising the cost of refining petroleum, mining coal, exploring for new energy deposits, and similar activities. This cost rise increases delivered energy prices, and the cycle continues.

Thus, the cost of fuels is doubly sensitive to the price of raw energy, both through use of the resources themselves and through the further use of energy in processing. For example, it may be calculated that at 1975 prices, about 20% of the cost of converting western subbituminous coal to synthetic crude oil (syncrude)--assuming the technology were available--would be due to the cost of raw energy--coal, crude oil and gas, and hydro and nuclear power. Of this 20%, feed coal for the liquefaction process comprises two-thirds of the cost; the other one-third is due to the direct and indirect consumption of energy required to run the process. In other words, coal liquefaction requires 530,000 Btu of raw energy to produce one dollar worth of product (1975 costs). This may be compared with the 40,000 Btu consumed per dollar of output

for U.S. industry as a whole and the 370,000 Btu per dollar of output (gasoline) for petroleum refining.

What must be concluded, therefore, is that energy analysis is a useful descriptive tool to complement economic analysis. The physical analysis of energy flows brings to light energy policy implications that may be buried in economic analysis. For example, energy analysis indicates that a national strategy to replace all imported crude oil with syncrude derived from coal would require (assuming imports at today's levels) the additional yearly production of 540 million tons of coal, 0.25 trillion ft³ of natural gas, and 13 billion kWh of electricity from hydro and nuclear power. The economic impacts of such a policy would also be enormous, of course, but perhaps no more so than the other impacts of producing these additional domestic resources.

Energy analysis indicates where increases in raw energy prices will have the greatest impact in the economy and indicates steps that industry can take to keep costs down as energy price increases. Of course, we do not argue that analysis of energy flows is the single, sufficient factor. Depending on the situation, analysis of other material flows could provide equally useful insights. However, recent abrupt increases in world energy prices and domestic supply constraints have made energy the focus of such analysis.

C. The Utility of Energy Analysis

Can energy analysis be used prescriptively in energy policy making? Or is it merely a useful descriptive tool to supplement economic analysis? In some cases the answer to the first question is clearly "yes." The simplest example would be an energy conservation program designed to save energy through the installation of insulation and double-glazed windows. Energy analysis could determine whether energy consumed in manufacturing insulation materials was greater or less than the potential energy savings to be derived over a designated time. When energy conservation is the goal, such a policy would be useless--regardless of economic costs or benefits--if there were no net savings of energy.

In many areas, however, energy analysis is open to question, and its utility in policy decisions has yet to be determined. Given these considerations, we have concluded that it seems best applied to energy conservation. Energy analysis applied to various resources, conversion technologies, distribution systems, and end-uses can clearly indicate options that conserve the nation's resources. These options will be strongly influenced by government policies toward research and development and energy prices (tax incentives or penalties, loan guarantees, depletion allowances, and so on). If the government decides that the development of certain options is in the national interest, then it may attempt to influence the market to enhance that development. Thus, because conservation of domestic energy resources has become a national goal, energy analysis can be important in guiding policy formulation.

However, conservation policy is not made in isolation, and energy price will ultimately determine the acceptability of any energy supply option. Thus, questions arise whether energy and economic analyses will support one another or will they reach divergent conclusions about the attractiveness of various options. It is desirable, for example, to attain the most energy-conservative options at low cost. This makes the decision-maker's task easier: Difficult tradeoffs are avoided. If the opposite is true, with costly implementation required for energy-conservative supply options, the question of tradeoffs must be addressed. Ultimately, a compromise will assign appropriate weights to the desirability of achieving conservation goals and the necessity of supplying energy at acceptable prices.

REFERENCES FOR CHAPTER 1

1. E. M. Dickson, et al, "Synthetic Liquid Fuels Development: Assessment of Critical Factors," U.S. Energy Research and Development Administration, ERDA 76-129/2 (1976).

Chapter 2

OBJECTIVES OF THE STUDY

A. Examination of Coal-Based Systems

To examine the relationship between energy consumption and monetary costs associated with different energy systems, we will analyze a number of coal-based systems potentially useful for supplying automotive propulsion. We include the coal-electricity-electric vehicle system, even though it represents a markedly different automotive technology. The other systems considered are compatible with conventional (albeit modified) automobiles that use internal combustion engines. We have structured our analysis for parallel calculations of energy consumption and money costs of delivered automotive energy.

All the systems analyzed represent technologies proposed as alternatives for supplying automotive energy within the 1985-2000 time frame. These systems (shown in Figure 2-1) include:

- Coal-fired electric power; electric vehicles.
- Coal liquefaction; refining to gasoline and distillates.
- Coal gasification/Fischer-Tropsch gasoline synthesis.
- Coal gasification/methanol synthesis.
- Coal gasification/methane synthesis.
- Coal gasification/conversion to hydrogen.
- In-situ coal gasification/methanol synthesis.
- In-situ coal gasification/methane synthesis.

The energy systems we consider also include transportation of coal and transportation and distribution of its conversion products.

B. Limitations of Idealized Systems

These systems are idealized and have been constructed to examine energy/economic tradeoffs. In practice, the production and distribution

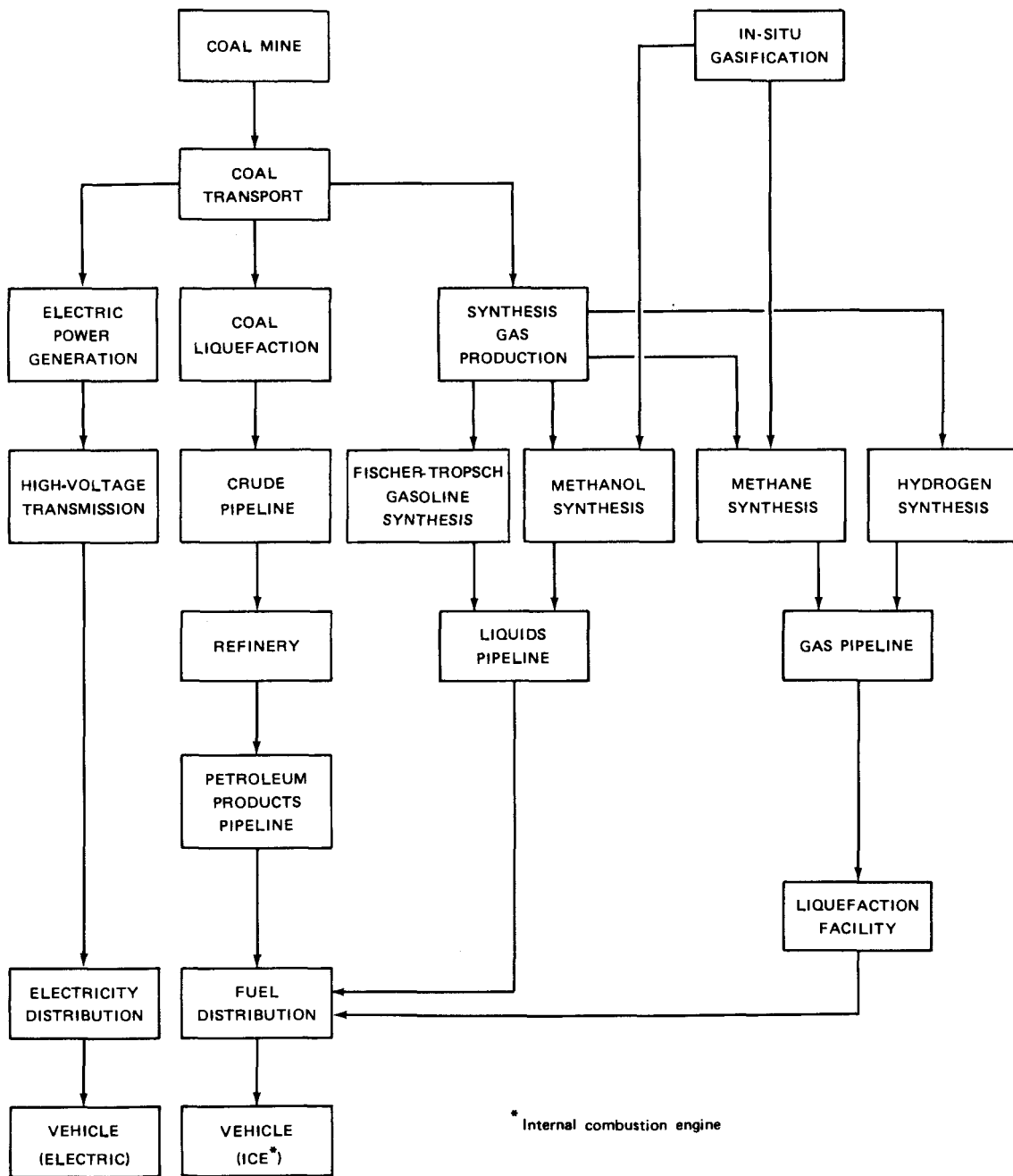

FIGURE 2-1. COAL-BASED AUTOMOTIVE ENERGY SUPPLY SYSTEMS

of synfuels would be considerably more complex than the subsequent analysis indicates. For example, syncrude produced from coal will probably be pipelined to refineries to be blended with natural crudes for refining into numerous products. Thus, the consumer will not pay the full price appropriate to a pure syncrude case; rather, he will pay an average price that accounts for the blending of the more expensive syncrude with the less expensive natural crude.

For electricity, the situation is the same. The utility will not distinguish among different electricity sources when billing its customers. The consumer will be billed at a rate that represents overall cost of producing electricity, rather than just the costs to build and operate a new coal-fired power plant. In contrast, however, a consumer would more than likely pay the full costs of delivering new fuels such as hydrogen or methanol if he chose to purchase them.

Thus, the analysis in the following sections considers only the marginal, or incremental, energy or money costs of adding new units of production to the automotive fuel supply system. To ascertain the weighted impact of such new units on average costs throughout the system, one would need to know the fraction of total automotive fuel supply made up by synfuels. Appendix A illustrates how the weighted energy impacts may be determined for syncrudes from coal and oil shale, and methanol from coal.

Note that the energy and money costs of producing vehicles that will use the synfuels (or electricity) are not considered. For this analysis, we assume that these costs are the same for all types of vehicles. This assumption represents a zeroth-order approximation. It is likely that the costs of a hydrogen-powered vehicle will differ from those of a gasoline-powered vehicle, which will differ from those of an electric vehicle, and so on. However, for many new vehicles, the engine/fuel storage combinations are still speculative and their costs are unknown. In addition, external factors such as pollution control regulations will play an important role. A hydrogen-powered vehicle, for example, would not require the use of a catalytic converter. This would help to offset the expense of a cryogenic fuel storage system. To illustrate the effect of vehicle costs, Appendix B summarizes the findings of an analysis of (1) vehicles powered by gasoline derived from synfuels and (2) electric vehicles.

The energy and money costs of producing the vehicles are considered explicitly.

We emphasize that the analyses that follow are not intended to be sufficient for choosing one system over another. Furthermore, the cost figures used in the economic analysis, which are derived from estimates published in publically available literature, are illustrative rather than definitive. The calculated costs of delivered fuels are indicative only of general cost trends and are not as accurate as more detailed engineering/economic analysis.

Chapter 3

ECONOMIC ANALYSIS

A. Objectives and Background

The analysis here is primarily concerned with developing information that can provide an economic perspective for the information generated by the energy analysis that follows in Chapter 4. This will enable the comparison of dollar costs with energy costs that are associated with the various technologies needed to produce automotive fuel.

A secondary purpose is determining total cost sensitivity to changing values assigned to factors dependent on the location of various energy facilities, as well as to significant cost-determining variables.

The analysis may also shed some light on policy-making aspects related to the development of alternative automotive fuels. In particular, the analysis will examine the relative merits of substitutes for the conventional petroleum system supplying automotive fuel; and the implications of uncertainties in cost-determining variables.

The considerations that follow underlie this study's economic analysis. Consistency between the economic and the energy analyses is essential. Therefore, identical energy supply systems with the same components--location of coal mines, conversions plants, and the markets for fuels and electricity--are analyzed for the two cases. Consistency among data (e.g., capital costs of gasification, liquefaction, and coal-fired power plants) is also important. We have attempted to ensure that costs are based on reasonable and consistent assumptions about financing, coal characteristics, and like factors. In the case of financing coal conversion facilities, for example (with the exception of electricity generation), we have assumed 100% equity financing and a 15% rate of return on capital based on the discounted cash flow (DCF) method in all cases.

Figure 3-1 shows the major components of the system that supplies gasoline produced from coal-based syncrude. Here, the cost of gasoline depends upon the costs of extracting, transporting, and converting coal; transporting and refining syncrude; and transporting, distributing, and marketing the gasoline. Each component cost depends on the values assigned to a number of cost-determining variables. For example, the coal extraction cost depends on such variables as the mining method used, coal-bed seam and thickness, and coal mine location. Consequently, we have to determine changes in gasoline cost that result from changes in the values of the cost-determining variables.*

B. Major Assumptions and Their Implications

The assumptions that have shaped our study and their implications are discussed below.

1. Costs Derived from the Coal Depletion Model

To make this study consistent with the synfuel impact assessments in Volumes II and III of this series, we use the results generated by the Coal Depletion Model in Volume III to estimate the following costs: coal extraction, coal transportation, and coal conversion.

However, actual costs could differ. To offset this difference, we include a sensitivity analysis to help determine the impact of cost changes on the total cost of synfuel supply.

2. Advanced Technology and Its Costs

Our cost estimates correspond to 1975 estimates of the most advanced technology and its costs. We have not allowed for additional

* Our analysis reflects current knowledge about the technologies needed to produce automotive fuel. Given the pace of synfuel research, our cost estimates may rapidly become obsolete. However, we are more interested in allowing the decision maker to weigh the relative merits of the various options than in generating precise numbers.

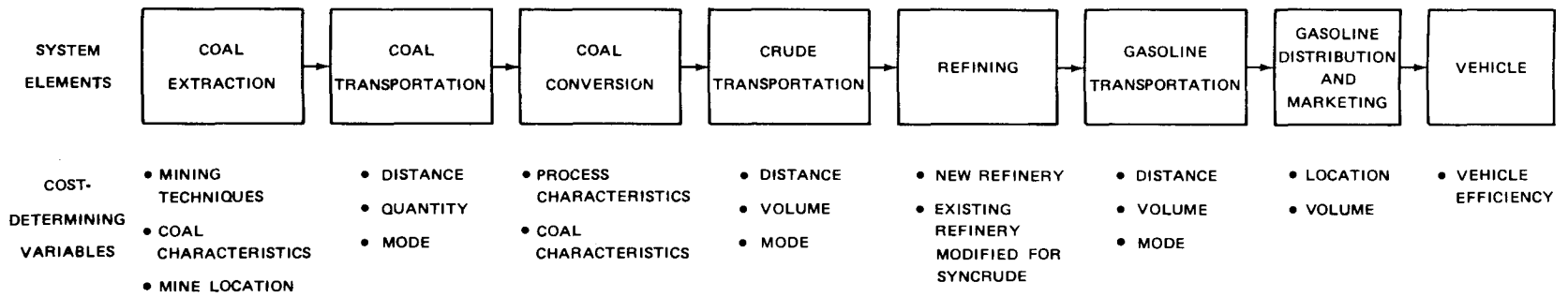

FIGURE 3-1. COMPONENTS OF THE SYNCRUDE/GASOLINE SYSTEM

economies-of-scale considerations, the "learning curve" phenomenon, or subsequent cost escalation.

However, the costs used here are likely to be lower than current estimates and the state of the art of technology is unlikely to be static. Both of these implications can be explored through sensitivity analysis.

3. Variations in Locations

The locations of coal mines, coal conversion plants, refineries, coal-fired power plants, and the markets for fuel and electricity can produce significant variations in the total cost of delivering fuel products to an automobile. Thus, we assume aggregate regionalization schemes and locate refineries in the seven regions that constitute the five Petroleum Allocation Districts (PADs), with PADs 4 and 5 each divided into two subregions.*

However, further division of these regions could improve the cost estimates. Nonetheless, we use the Federal Energy Administration (FEA) regionalization schemes for simplicity. To minimize data collection, we generally use publicly available data.

4. Use of Historical Costs

The cost estimates for transporting crude oil and petroleum products, distributing and marketing gasoline, and transmitting and distributing electricity are based on historical data to 1974. We have inflated these costs to 1975 dollars using appropriate indices.

However, actual costs could differ from these assumed costs. Again, we employ sensitivity analysis to determine the impact on total cost of delivering gasoline or electricity to the automobile if the costs should differ from those in the analysis.

5. Vehicle Efficiencies

We assume that vehicles operating on different fuels will have different efficiencies. For example, vehicles using conventional internal

*This scheme was first used by FEA in the Project Independence Report.¹

combustion engines are assumed to be less efficient than electric automobiles.

Therefore, costs expressed in cents/mi exhibit different trends than those expressed in units such as $\$/10^6$ Btu. Assumed efficiencies may not carry over to the real world. Thus, we have analyzed variations in the cost of transportation resulting from different efficiencies.

C. Approach

We develop means to ascertain the total cost of delivering automotive fuel in terms of the component costs for alternative pathways for using coal in automotive transportation (see Figure 2-1). The final cost of delivered energy is calculated by a "value added" approach. The cost of each component is referred to the quantity of energy delivered so that the total cost may be evaluated by a simple summation.

Figure 3-2 is a flow chart that depicts the components of total cost for the alternatives in this study. Because a comprehensive analysis of locational impacts on cost would be inordinately time consuming, we determine the range over which the costs could vary. For example, the cost for a given transportation mode of transporting crude from a syncrude production facility to a refinery depends on the location of the two facilities. The cost can be precisely determined in a number of ways; they range from detailed engineering/economic analysis to optimization model use. Our approach is to first locate the syncrude production facility in 1 of the 14 crude supply regions, and then determine the cost by considering all possible paths to refineries in various PADs. This procedure yields a range of values for transporting crude; the range is determined by the number of possible supply-demand pairs considered. The maximum, minimum, and average values are then identified from this range of values.

1. Component Cost Computation

The following components of the total cost were obtained from the Coal Depletion Model: coal extraction costs, coal transportation

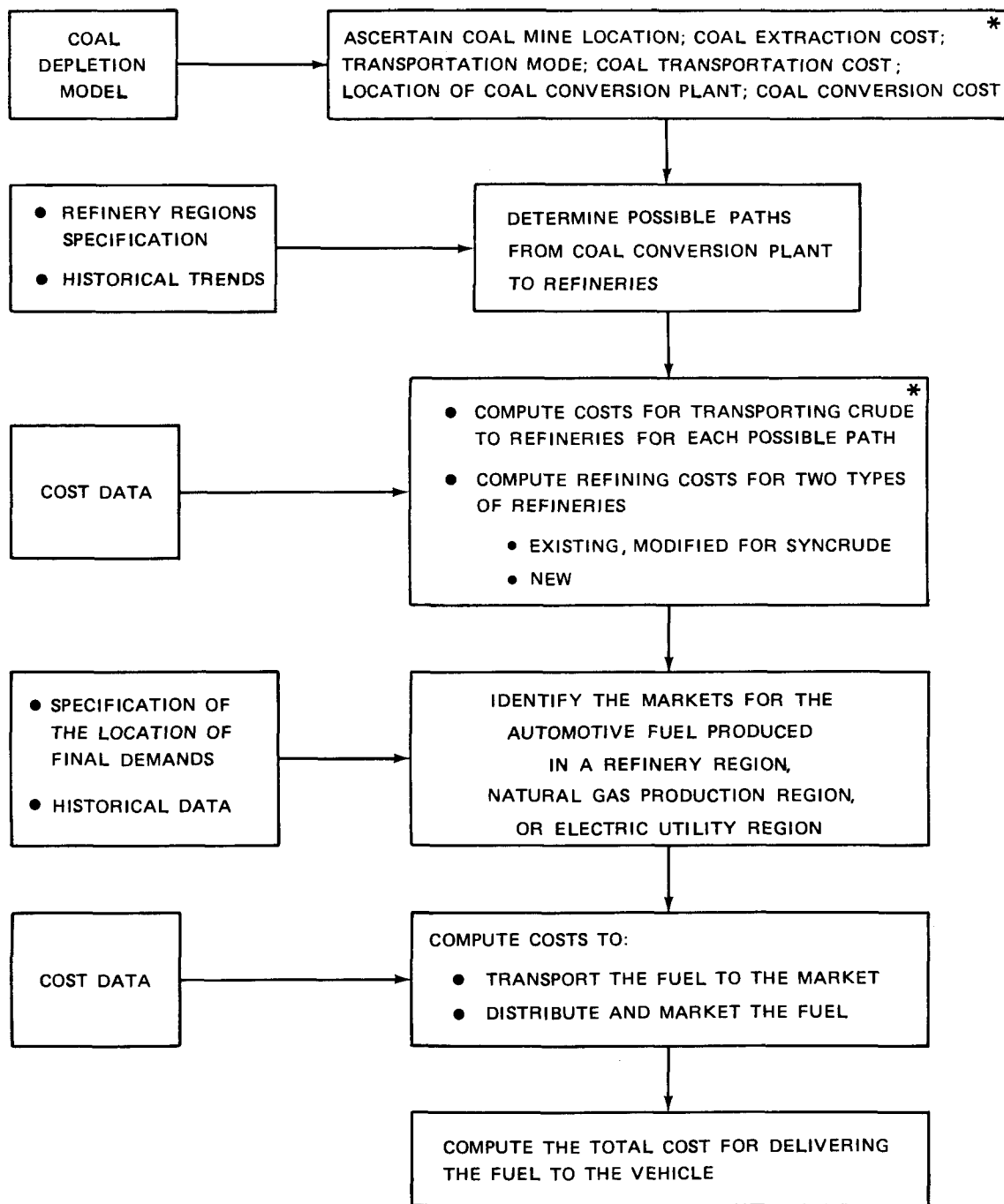

* These computations are made only if the coal conversion plant produces syncrude

FIGURE 3-2. FLOW CHART FOR AUTOMOTIVE ENERGY COST CALCULATIONS

costs, and coal conversion costs for syncrude, methane, and electricity. The locations of the coal conversion plants were also supplied by this model and were based on the Dispersed Scenario for 1990. Coal conversion costs not contained in the Coal Depletion Model--hydrogen, methanol, and Fischer-Tropsch gasoline--were obtained from the literature and are employed in the same way as the model outputs. Sources for these cost estimates are referenced in Appendix D. Using these component costs, the method of calculating the overall cost is discussed below.

The cost of transporting syncrude to a refinery is determined by first translating the location of coal conversion plants into one of the FEA's crude oil supply regions. Using historical information, the possible pathways to the refinery regions from this supply region are determined. The refinery regions correspond to the FEA's refinery regions.¹ The transportation costs from the supply region to the refinery region were obtained from published sources, particularly FEA and the Department of Transportation (DOT).² These figures represent distances and volumes involved, and correlate well with other sources such as American Petroleum Institute (API) data.³

The costs of refining the syncrude are obtained for two cases: an existing refinery, modified to handle crude; and a new refinery. The cost data were obtained from previous SRI work⁴ and work done by Exxon⁵, and updated to 1975 costs.

The cost of transporting fuel from the refinery to the market (or the fuel from coal conversion plant, to the market, when refining is not involved) can be calculated if the locations of the supply source and the demand center are known. For the demand side, the Bureau of Census regions are used. For the supply side, the modified PADs are used for locating refineries, as well as conversion plants that produce synthetic gasoline or methanol. For methane and hydrogen, natural gas-producing regions used in the FEA Project Independence Report are used.¹ For electricity, FEA electric utility regions are used. With the location of supply and demand centers known, the transportation costs are determined from published data, principally from FEA¹, DOT², Federal Power Commission (FPC)⁶ and API.³

For each demand center, the distribution and marketing costs are obtained from FEA statistics for gasoline⁷, from FPC publications concerning electricity⁶, and from Exxon for remaining fuels⁵. These data seem representative when compared with other sources such as Energy Prices 1960-73 by Foster Associates⁸. For fuels such as methanol and hydrogen, the data allow for handling such fuels⁵. For methane and hydrogen, the cost of liquefaction is also included⁵.

2. Computer Program

Our approach uses a computer program to determine the component costs for each alternative system shown in Figure 2-1. The program computes the delivered energy costs for each pathway. It also prints the minimum, maximum, and average delivered energy costs for coal conversion originating in each crude production, gas production, refinery, or electric utility region where the Coal Depletion Model has located a facility.

Program inputs are the type of fuel and the location of the coal conversion plant. The data on possible pathways from supply to demand centers, as well as the costs of conversion, transportation, and distribution, are stored in the program. Program outputs are the cost of each component (e.g., refining) and the total cost of delivering energy to the automobile.

D. Computational Results

The results obtained from the computational approach are described in the following three subsections. To simplify comparisons, only the maximum and minimum costs for all possible pathways are shown for each option. The costs derived by our computations correspond only to the fuel portion of the total cost of an automobile. The data accuracy, especially the production costs of synfuels, is mixed. Therefore, the interfuel comparison is not exact and should be considered only in relative terms. Because the estimates of production costs of synfuels undergo rapid revisions as costs escalate, a relative comparison is more significant. (This assumes, of course, that the cost revisions for all

synthetic fuels occur in the same direction.)

1. Comparison of the Options

The comparison of the six options above is shown in Figure 3-3 in units of $\$/10^6$ Btu (delivered to the vehicle) as well as in units of cents/mi. The translation of $\$/10^6$ Btu into cents/mi requires assumptions about efficiency of vehicles with internal combustion engines that operate with different fuels and vehicles powered by electricity. The following automotive efficiencies are assumed⁹:

Gasoline	- 4200 Btu/mi [*]
Methanol	- 3430 Btu/mi
Methane	- 3860 Btu/mi
Hydrogen	- 3190 Btu/mi
Electricity	- 1540 Btu/mi [†]

In Figure 3-3, the various options are compared with a gasoline derived from natural crude and costing 50 cents/gal, excluding taxes. The comparison shows that, in terms of $\$/10^6$ Btu, syncrude/gasoline is the least costly option, whereas electricity is the most costly option.

Between syncrude and electricity, the option range is as follows (in order of increasing costs): syncrude, methanol, methane, Fischer-Tropsch gasoline, and hydrogen. In relative terms, the hydrogen option costs twice as much as syncrude/gasoline, which in turn is about 1.5 times as expensive as the natural crude/gasoline option. However, the differences between options vary considerably. For example, the difference between hydrogen and electricity is about 5%, between methanol and Fischer-Tropsch gasoline about 14%, and between hydrogen and methane options about 23%. Considering the uncertainties in the estimates of various component costs, and in production costs in particular, these differences should be interpreted cautiously. The syncrude/gasoline option, however, does appear to be superior, on a $\$/10^6$ Btu basis, to any other option.

* For this analysis, the base case gasoline-powered automobile is a subcompact with fuel economy of 30 mpg.

† 0.45 kWh/mi, corresponding to an electric car powered by an advanced battery (e.g., lithium-sulfur)¹⁰.

3-10

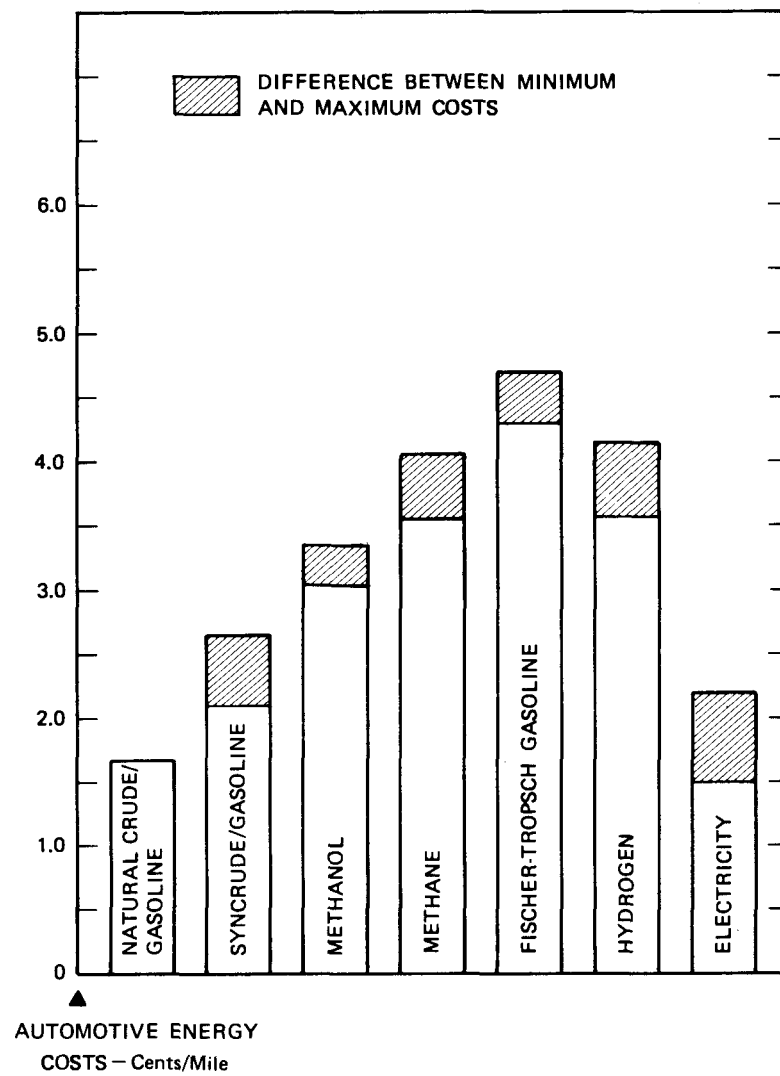
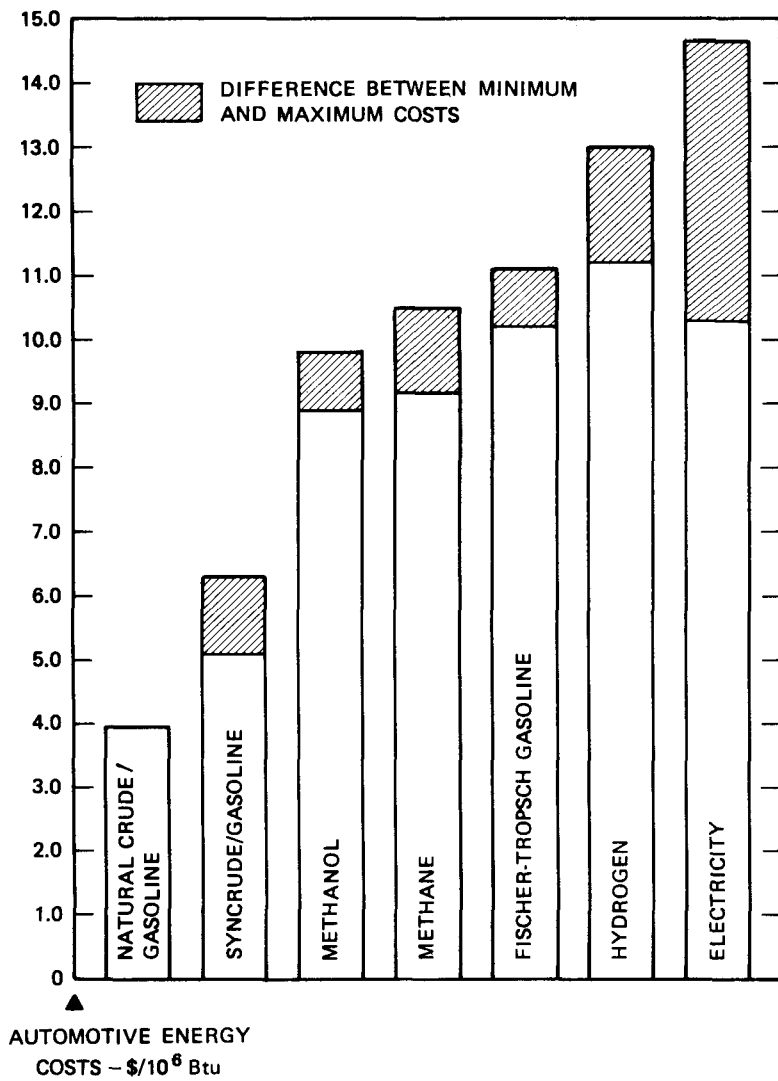

FIGURE 3-3. COMPARISON OF AUTOMOTIVE ENERGY COSTS

2. Impact of Changing Vehicle Efficiencies

If the vehicle efficiencies (in Btu/mi) are considered, the comparisons are different. The electricity option becomes the least-cost option, primarily because of the assumed high efficiency of the electric vehicle (see Figure 3-3). Differences among other synfuels are not so pronounced, with the exception of syncrude/gasoline. All the synfuel options are still more costly than the natural crude gasoline option.

Of course, the validity of the assumed vehicle efficiencies can be questioned. Figure 3-4 shows the sensitivity of the cost to the changes in the values assumed for vehicle efficiency, using average costs to compute the straight line slopes and vertical bars to represent the minimum/maximum variations.

Three groupings with considerable differences can be observed. These are, in order of increasing costs: electricity and syncrude/gasoline; methanol, methane, and hydrogen; and Fischer-Tropsch gasoline. The differences between these groups are significant.

If other options are to match the cents/mi cost of electric vehicles, the relevant engine efficiencies must increase by the following factors: syncrude/gasoline--1.27; methanol--1.68; methane--1.99; Fischer-Tropsch gasoline--2.33; and hydrogen--1.99.

These figures must be cautiously interpreted, however, because other costs of the electric option (i.e., costs of producing an electric vehicle and of overcoming institutional inertia) may outweigh its fuel cost advantages. Nevertheless, Figure 3-4 does show that the electric vehicle option greatly improves its standing in respect to the synfuel options if the proper vehicle efficiencies are taken into account. Also, if the efficiencies of vehicles running on fuels other than gasoline are significantly lower than those in Figure 3-4, the gap between syncrude/gasoline and these options widens even further.

3. Costs of In-situ Gasification Options

In-situ costs were calculated for two cases: methane and methanol. The costs were computed by the same procedure as that used for

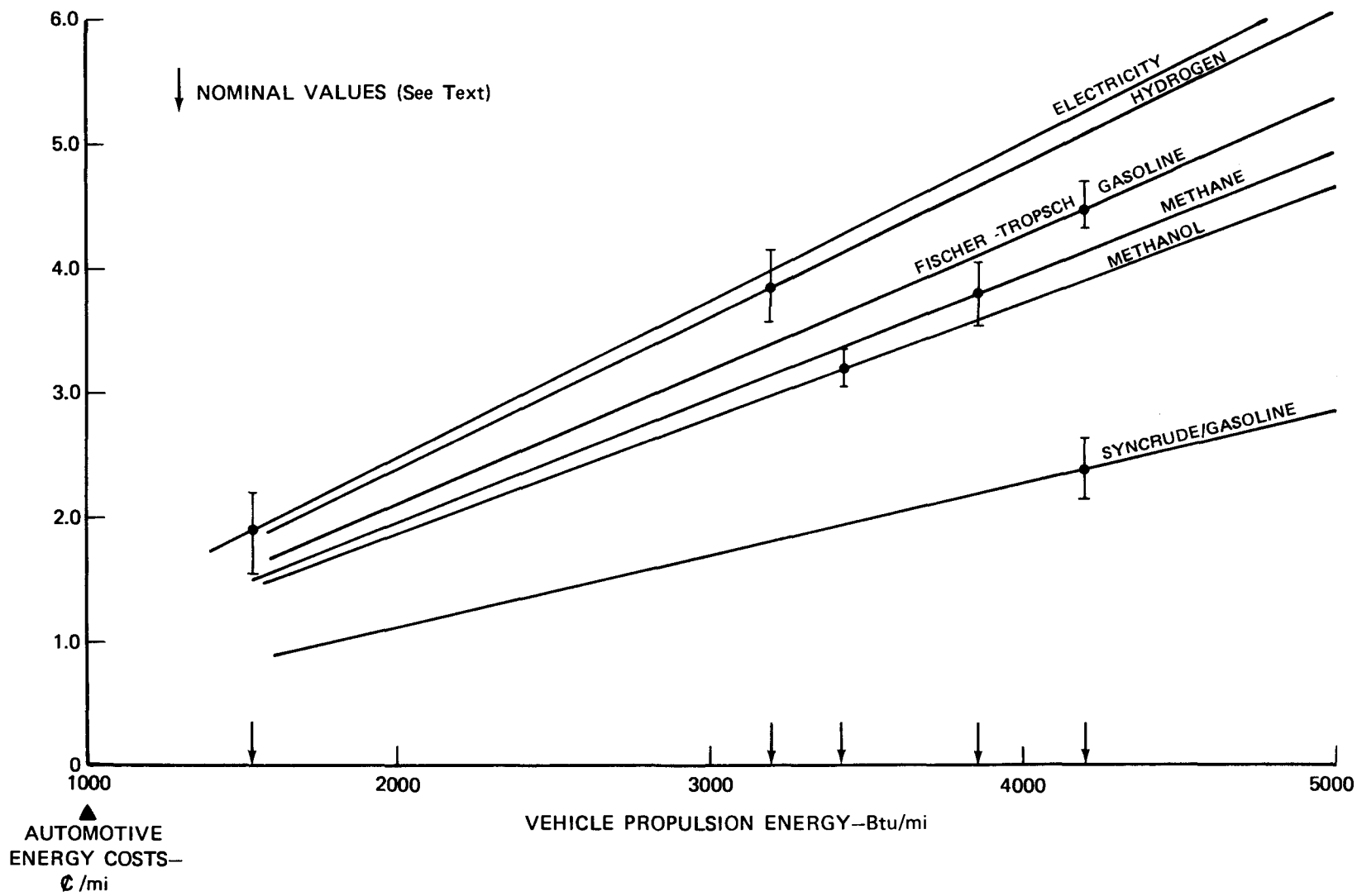

FIGURE 3-4. VARIATION OF AUTOMOTIVE ENERGY COST WITH VEHICLE PROPULSION ENERGY REQUIREMENTS

the conventional mining cases. The costs for in-situ gasification were obtained from the Coal Depletion Model, and the costs of methanation and methanol synthesis were obtained from publications cited in Appendix D. The costs for fuel transportation and distribution are identical to the case where the fuels are derived using conventional mining technologies.

The minimum and maximum costs for the two cases is shown in Figure 3-5. Comparison with the conventional mining case indicates significantly lower costs for the in-situ option. If the vehicle efficiencies are considered, both options are comparable to the syncrude/gasoline option.

The sensitivity analysis indicates that the total cost for the case of methane is quite sensitive to the changes in cost estimates for liquefaction and product distribution and moderately sensitive to other parameters. For the case of methanol, the total cost is quite sensitive to coal conversion and product distribution costs and least sensitive to changes in methanol transportation costs. The variations in total costs due to regional differences are smaller than those for the conventional mining case, mostly because only one region--Wyoming--was considered for in-situ conversion, and the only variation in delivered fuel cost is due to the variation in transportation distances for methanol and methane.

E. Sensitivity to the Regional Differences

The differences between the minimum and maximum values for automotive energy costs displayed in Figure 3-3 are contributed by regional variations resulting from: (a) coal conversion plant location, (b) refinery location for syncrude, and (c) market location. The differences resulting from the location of coal conversion plants are directly reflected in the coal extraction cost, coal transportation cost, cost of transporting synthetic crude to a refinery, and the cost of transporting methane, methanol, hydrogen, and electricity to market. The refinery location causes differing costs of transporting gasoline to the market. Market locations affect the cost of distributing and marketing the final product.

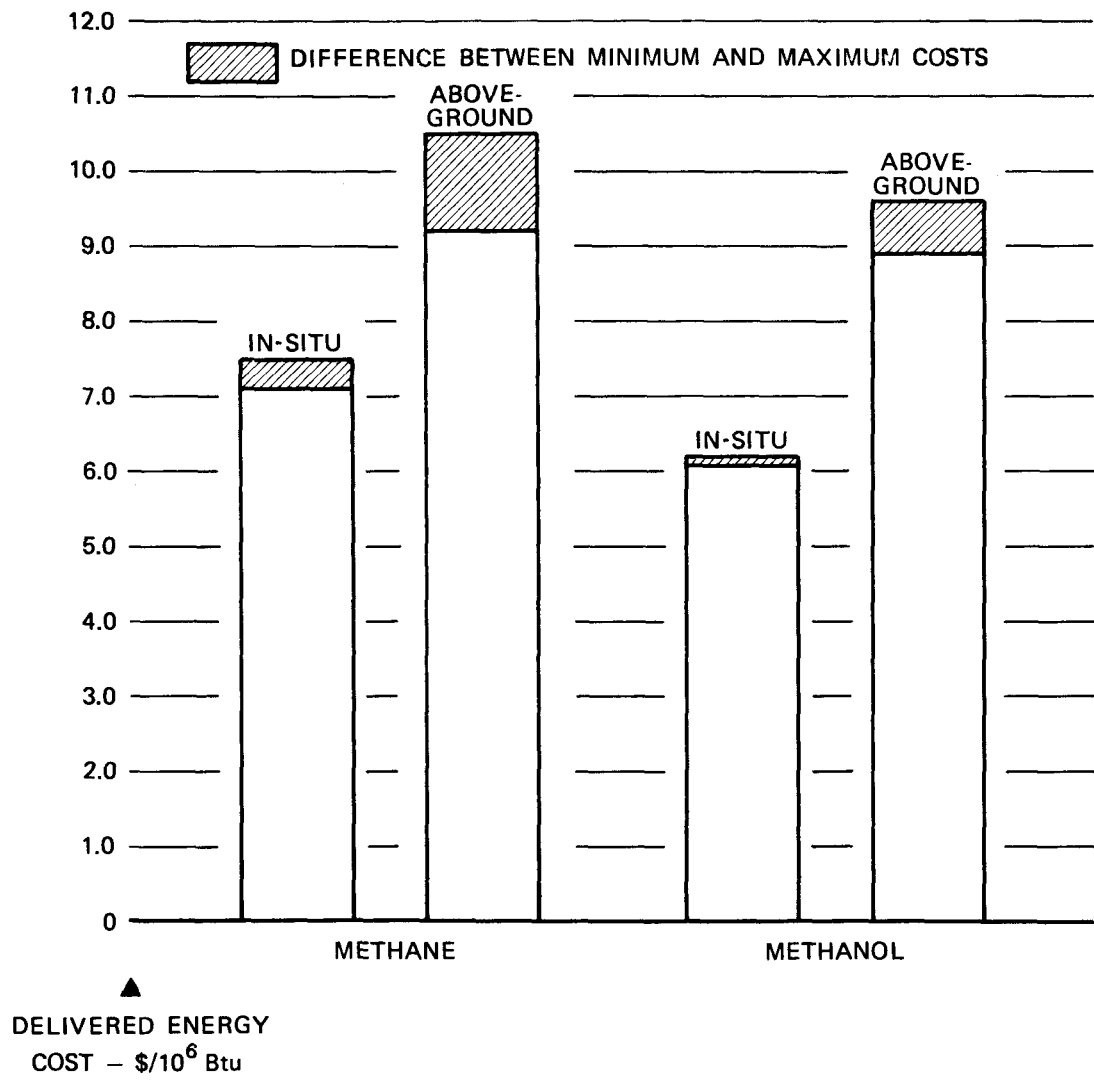

FIGURE 3-5. COMPARISON OF DELIVERED METHANE AND METHANOL COSTS USING IN-SITU AND ABOVE-GROUND COAL GASIFICATION

Table 3-1 summarizes the regional differences that produce minimum and maximum costs.* As indicated, a coal conversion plant near a coal mine is usually the least-cost option, primarily because coal transportation cost usually exceeds the cost of transporting the final product either from the refinery or from the coal conversion plant. In addition, regional variations in distribution costs are less than variations in coal transportation costs.

F. Sensitivity to the Variations in Cost Parameters

As noted earlier, the sensitivity analysis considers the impact on total cost of the changes in cost of the following factors: coal extraction, coal transportation, coal conversion, refining, product transportation, and product distribution. The details of this analysis can be found in Appendix C.

The results of sensitivity analysis are summarized in Figure 3-6. Note that the greatest improvement in the estimates of delivered fuel costs can be gained by better costs estimates for coal conversion, product liquefaction, and product distribution. Changes in coal extraction and transportation cost produce only modest changes in the total cost when compared with the cost of coal conversion, product liquefaction and product distribution. The total cost shows little sensitivity to changes in cost of transporting the product. The sensitivity to changes in the refining cost of syncrude is also significant.

*The information in this table must be cautiously used. For example, it is unwise to generalize that minemouth is the best option. First, limitation in networks carrying the fuel from the coal conversion plant to a refinery or to markets of final demand must be analyzed. The analysis must also consider the location of existing refining centers.

Table 3-1
COST SENSITIVITY TO REGIONAL DIFFERENCES

	<u>Cost</u> <u>(\$/10⁶ Btu)</u>	<u>Percentage</u> <u>Difference</u>	<u>Coal Conversion</u> <u>Plant Location</u>	<u>Coal Type</u>	<u>Refinery Location</u> <u>(PAD Districts</u> <u>as modified by FEA)</u>	<u>Market/Final Demand</u> <u>Location</u> <u>(Census Region)</u>
1. <u>Syncrude/</u> <u>Gasoline</u>						
maximum	6.30		Beaumont, TX	Appalachian Underground	PAD 2A, 2B, or 3	New England/Middle Atlantic
minimum	5.10	24%	Billings, MT	Montana Surface	PAD-4	Mountain/West North Central
2. <u>Methane</u>						
maximum	10.50	14%	New Orleans, LA	Illinois surface	NA	New England/Middle Atlantic
minimum	9.20		Gillette, WY	Wyoming surface	NA	Mountain
3. <u>Methanol</u>						
maximum	9.80	10%	Galveston, TX	Appalachian Surface	NA	New England/Middle Atlantic
minimum	8.90		Billings, MO	Montana Surface	NA	Mountain/West North Central
4. <u>Fischer-Tropsch</u> <u>Gasoline</u>						
maximum	11.10	9%	Galveston, TX	Appalachian Surface	NA	New England/Middle Atlantic
minimum	10.20		Billings, MT	Montana Surface	NA	Mountain/West North Central
5. <u>Hydrogen</u>						
maximum	13.00	16%	Galveston, TX	Appalachian Surface	NA	New England/Middle Atlantic
minimum	11.20		Chicago, IL	Illinois Surface	NA	East North Central
6. <u>Electricity</u>						
maximum	14.70	43%	Boston, MA	Appalachian Surface	NA	New England/Middle Atlantic
minimum	10.30		Charleston, SC	Appalachian Surface	NA	South Atlantic

	SYNCRUDE/ GASOLINE	FISCHER-TROPSCH GASOLINE	METHANOL	METHANE	HYDROGEN	ELECTRICITY
COAL EXTRACTION	△	△	△	△	○	○
COAL TRANSPORTATION	△	△	△	△	○	○
COAL CONVERSION	□	□	□	□	□	□
CRUDE TRANSPORTATION	○	NA	NA	NA	NA	NA
REFINING	□	NA	NA	NA	NA	NA
PRODUCT TRANSPORTATION	○	○	○	△	○	NA
PRODUCT LIQUEFACTION	NA	NA	NA	□	□	NA
PRODUCT DISTRIBUTION	□	△	□	□	□	NA
ELECTRIC TRANSMISSION AND DISTRIBUTION	NA	NA	NA	NA	NA	□

- LEAST SENSITIVE
 △ MODERATELY SENSITIVE
 □ MOST SENSITIVE
 NA NOT APPLICABLE

FIGURE 3-6. SUMMARY OF SENSITIVITY ANALYSES

REFERENCES FOR CHAPTER 3

1. "Project Independence Blueprint, Final Task Force Report - Transportation," Vols. I and II, Federal Energy Administration (November 1974).
2. "Energy Statistics: A Supplement to the Summary of National Transportation Statistics," Department of Transportation, DOT-TSC-OST-73-34 (September 1973).
3. "Annual Statistics" (1973) and Petroleum Facts and Figures (1971), American Petroleum Institute.
4. R. L. Goen, et al, "Synthetic Petroleum for Department of Defense Use," Stanford Research Institute (November 1974).
5. F. H. Kant, et al, "Feasibility Study of Alternative Fuels for Automotive Transportation," Vols. II and III, Exxon Research and Engineering Co., U.S. Environmental Protection Agency EPA-460/3-74-009c (June 1974).
6. "National Power Survey," Vol. I, Federal Power Commission (1970), and "Electric Power Survey," Annual Report, Edison Electric Institute (1975).
7. "Basic Energy Data and Glossary of Terms," U.S. House of Representatives, Committee on Interstate and Foreign Commerce, 94th Congress (1975).
8. Energy Prices 1960-73, Foster Associates, Inc. (Ballinger Publishing Co., Cambridge, 1974).
9. E. M. Dickson, et al, The Hydrogen Energy Economy: A Realistic Appraisal of Prospects and Impacts (Praeger Publishers Inc., New York, 1977).
10. E. E. Hughes, et al, "Long Term Alternatives for Automotive Propulsion-Synthetic Fuel Versus Battery/Electric System," Stanford Research Institute (August 1976).

Chapter 4

ENERGY ANALYSIS

A. Methodology

Since the concept of net energy began to receive widespread attention several years ago, articles and reports have explored applications of the concept and have made numerical calculations for a variety of energy systems. In addition, workshops have been held to clarify the meaning of energy analysis and to produce a definitive methodology.

In spite of this activity, those involved in energy analysis still do not agree about its definition or its usefulness. In the area of methodology, however, it is generally recognized that several legitimate approaches exist, each of which has its advantages as well as its drawbacks. Three of the most useful approaches are discussed below.

1. Process Analysis

This is undoubtedly the most intellectually straightforward of all the approaches applied to energy analysis.¹ It was devised to determine the total energy consumed in producing such products as automobiles and containers, but it can be applied to fuel production just as readily. It thermodynamically analyzes each process in the chain of activities that are required to produce and deliver a given amount of product (e.g., 1 ton of aluminum). This procedure can be characterized as a vertical analysis because it follows the flow of materials from the basic resources through the processing steps required to deliver a product, explicitly evaluating the energy consumption at each stage. When materials other than those in the main process stream are consumed or added to the process, the energy consumed in producing these materials is evaluated as another source of energy use.

Ultimately, the direct energy consumption associated with each stage of manufacturing is added to indirect energy consumption to yield the total energy required to deliver a unit of the product. Typically, the total energy requirement of the manufacturing and distribution processes is broken down diagrammatically so that the major areas of energy consumption may be clearly discerned.

If the goal of the calculation is a net energy analysis of an energy conversion technology, the procedure differs only in that the unit quantity of the end product (typically a fuel or electricity) is expressed in appropriate energy units, such as Btu.

The process analysis approach is attractive because it clearly displays the energy contribution of each step in the sequence of steps that leads to the production of the final product. The detailed data sources that support the calculation of energy consumption in each step can be given in footnotes, allowing the reader to verify the numerical values in the analysis independently. Furthermore, technological advances or alternative processes that change the efficiency or energy consumption of any step can be easily incorporated in the analysis.

The major disadvantage of process analysis is that the calculation of second- or third-order contributions to energy consumption (e.g., the energy consumed in producing mining equipment used in mining iron ore that is used to produce steel for power plants) becomes tedious. And considerable branching quickly occurs one or two levels away from the main process sequence. Thus, a simple rule of thumb is that second- or higher-order contributions should be abandoned once numerical contributions become the same order as the range of error in the calculations for the main process sequence. Nevertheless, substantial effort can be expended in discovering which higher-order contributions are significant and which are not. The technique that follows provides an alternative, concise mathematical means of accounting for such higher-order effects.

2. Input-Output Analysis

The use of input-output analysis to describe the flows of goods and services in the U.S. economy has been a powerful tool of economic theory since it was introduced in the 1930s. It has been only recently, however, that this approach has been extended to include flows of energy, primarily by Robert Herendeen and Clark Bullard of the University of Illinois.²

To formulate an input-output description of the economy, all business activities contributing to the nation's GNP are grouped into sectors; each sector represents activities of a particular type (e.g., coal mining, canned sea foods, cigarettes, and textile goods). Currently, the largest number of sectors used is 368. The transactions measured in dollars' worth of sales per year between each sector and all other sectors are tabulated and displayed as a matrix of 368 rows and 368 columns. In addition, the sales of each sector to final demand (personal consumption, government purchases, purchases of capital goods, and the like) are tabulated.

The extension of this economic input-output formulation to energy input-output requires additional data on the direct consumption of energy by each of the 368 economic sectors. In other words, each sector's actual purchases of coal, petroleum products, natural gas, and electricity must be determined. (Crude oil and gas are purchased only by the refined petroleum products and gas utilities sectors.) Once these data have been incorporated with the dollar flow input-output structure of the economy, a computer can calculate the total direct and indirect energy consumption embodied in a dollar's worth of goods or services purchased from any sector. If, for example, an automobile is purchased from the motor vehicles and parts sector for \$4,000, the total energy consumed in the production of that automobile can be determined. This total energy consumption includes both the energy consumed directly by the motor vehicles and parts sector as well as the energy consumed by all the sectors that supplied it, all the sectors that supplied these sectors, and so on. In other words, the flows of energy in the production of any goods or service and traced back automatically through all

other sectors of the economy to determine the total consumption of resource energy required to deliver the goods or service. For five energy sectors--coal mining; crude oil and gas production; petroleum refining; gas utilities; and electric utilities--the energy requirements are expressed in energy consumed per Btu of output. This constitutes, in effect, a net energy calculation for each of these sectors.

A net energy analysis of new energy technologies, such as oil shale or solar energy using the input-output method depends on the ability to disaggregate the capital and operating costs associated with the technology into specific economic sectors. Purchases from these sectors are then converted into energy flows as outlined above, and the total energy required to produce a given amount of a product can be calculated. This calculation assumes a small contribution from the new technology to the overall energy budget of the United States. Thus, feedback loops--the flow of energy from the output of the technology through other sectors and back to that technology as indirect energy consumption--can be ignored. These feedback effects, however, cannot be ignored in a mature industry such as petroleum refining.

The main disadvantage of input-output analysis is that even at the level of disaggregation of 368 sectors, each sector may contain a wide variety of activities. The energy required to produce a dollar's worth of output in one industry may be quite different from that required in another industry, even though both industries are classified in the same sector. As a result this analysis may lead to significant errors in some calculations. Nevertheless, input-output analysis remains a powerful technique for tracing flows of energy through the U.S. economy.

3. Odum's Approach

A key feature of the school of thought evolved by Howard Odum and his students, and now receiving widespread attention, resides in the explicit consideration of natural energy flows as they affect man.³ Odum was among the first to point out that many of man's activities are "subsidized" by nature in the form of "free" services that are lost when natural ecosystems are disrupted. Often, these lost services can be replaced

only through man-made technologies that require large subsidies of materials and fossil energy. Thus, the energy subsidies in natural systems that may be disrupted or destroyed by implementation of an energy technology must be explicitly evaluated as an energy cost.

Oil shale will serve as an illustration in the hypothetical case that follows. Oil shale retorting and upgrading would require large amounts of water from the upper Colorado River. This water is relatively pure. If unused, it dilutes the water of the lower Colorado, which is contaminated with dissolved salts. Removal of upper Colorado water thus increases the salinity of the lower Colorado, which is used to irrigate crop lands. If this water becomes too saline for irrigation, desalination plants have to be built. Construction and operation of these plants require materials and energy. Thus, a natural subsidy will have been destroyed, and the energy equivalent of the service might logically be charged against the energy output of the oil shale industry, as well as against other energy industries using upper Colorado water.

Although the concept of natural energy subsidies has received wide acceptance among energy analysts, another feature of Odum's approach has remained controversial: energy quality. The quality of a particular fuel or energy form has been traditionally defined by the thermodynamic quantity known as "availability." The availability of an energy form is defined as its ability to do work, expressed in precise mathematical terms. Odum, however, has gone beyond thermodynamic definitions of quality to include the ways in which conversion of one energy form to another results in the "concentration" of useful energy. For example, Odum considers that fossil fuels are 2000 times more concentrated than sunlight. (Sunlight must be fixed photosynthetically by plants which, decaying over millions of years, are converted to oil or coal.) And Odum considers that electricity is about 3.5 times more concentrated than fossil fuels. (Note that these conversion factors appear to depend on the energy conversion pathways chosen for analysis.)

Because Odum's energy quality ideas have so little relation to thermodynamic concepts, this divergence must be resolved before his techniques find widespread acceptance among energy analysts. In spite of

this, and other areas of lesser controversy such as evaluating the labor contribution to energy inputs, most aspects of Odum's approach to net energy analysis substantially agree with the methods of other practitioners.

4. Net Energy Analysis--A Practical Approach

Each approach to net energy analysis described thus far has advantages and disadvantages. In many applications, a practical, reasonably accurate approach that minimizes the disadvantages of each of the methods is sought. In practice, this approach tends to combine aspects of process analysis, input-output analysis, and the Odum approach.

A net energy analysis of a specific technology usually begins with the process analysis approach. Flows of energy associated with the technology are quantified from available engineering design studies or other data. Energy flows may take the form of product output, thermodynamic conversion losses, physical losses, electricity consumption, and the like. In addition, when practicable, process analyses are conducted to determine indirect energy consumption in the form of materials use.

In many instances, however, materials consumption data for construction and operation of the technology are unavailable. In this case, estimates of the dollar costs of these activities are used in conjunction with input-output tables to estimate indirect energy consumption.

Finally, when technology interacts significantly with natural systems, Odum's approach can be used to evaluate lost natural energy subsidies. In many cases, these losses are small compared with the output of the energy technology in question.

All calculations carried out in this chapter use the approach outlined above. A detailed discussion of the calculation methods for surface coal mining, coal liquefaction, coal-to-methanol conversion, and oil shale retorting and upgrading are in Chapter 5 of Volume II of this series.⁴

B. Calculations on System Components

To carry out calculations for the systems described in Chapter 1 of this volume substantial data are required not only for the energy conversion technologies but also for mining, transportation, and distribution components. The data required include information on capital and operating costs, material inputs, process variables, fuel consumption, and the like. Generally, these data are in the literature on various energy conversion technologies and other components of the energy supply system. And, in fact, we have relied on this literature in carrying out our calculations. However, this literature should be approached with caution. Many process parameters for advanced technologies are still speculative. In other, better-known areas such as transportation many conflicting data exist. Thus, care must be taken before selecting data for direct use in the energy analysis. In some cases, the data must be modified because they do not completely account for all relevant energy inputs.

As in the work on net energy analysis in Volume II, all energy inputs into the system are referenced to primary energy resources--coal, crude oil, and gas, as well as to nuclear and hydro power. This determines the total quantity of energy resources required to deliver a unit of product. Theoretically, energy inputs can be broken down into each type of resource. However, this level of detail was not considered necessary for the analysis here. (For an example of the results of the entire procedure, see Appendix A.)

These techniques and qualifications have been applied to the energy systems described in Chapter 1. The computations of energy inputs into each component of the systems are presented in Appendix D.

Table 4-1 summarizes the energy requirements for the systems components analyzed in Appendix D. The tabulations are used in calculating the total system energy requirements for each automotive fuel in a manner parallel to fuel costs calculated in the previous section. Like the cost analyses, these figures are meant to be illustrative, rather than definitive, and are based on specific technologies. Advances in technology

Table 4-1

ENERGY REQUIREMENTS FOR COAL-TO-AUTOMOTIVE
FUELS SYSTEM COMPONENTS

Component	Energy Efficiency	Ancillary Energy (Btu/10 ⁶ Btu output)
Coal mine		
Surface	1.0	$2.8 \times 10^5/\text{HV}^*$
Underground	1.0	$3.4 \times 10^5/\text{HV}$
Coal transport		
Truck	1.0	$(2000/\text{HV}) \times L^\dagger$
Unit train	1.0	$(490/\text{HV}) \times L$
Slurry pipeline	1.0	$(760/\text{HV}) \times L$
Barge	1.0	$(300/\text{HV}) \times L$
Coal conversion		
Syncrude (bituminous coal)	0.68	2.7×10^4
Syncrude (subbituminous coal)	0.63	2.7×10^4
Methane	0.56	2.7×10^4
Methanol	0.40	4.0×10^4
Fischer-Tropsch gasoline	0.30	4.9×10^4
Hydrogen	0.59	3.7×10^4
Electricity	0.35	6.3×10^4
In-situ methane	0.76	2.3×10^5
In-situ methanol	0.65	4.6×10^5
Product transport		
Crude pipeline	1.0	48 x L
Methane pipeline	$1.0 - 3.6 \times 10^{-5}L$	4 x L
Hydrogen pipeline (gas)	$1.0 - 5.2 \times 10^{-5}L$	5 x L
Methanol pipeline	1.0	30 x L
Petroleum products pipeline	1.0	15 x L
Electricity transmission and distribution	0.91	$12 \times L + 0.1 \times 10^4$
Refinery	0.96	6.2×10^4
Methane liquefaction	0.83	0.6×10^4
Hydrogen liquefaction	1.0	1.1×10^6
Automotive fuel distribution		
Gasoline distribution	1.0	0.5×10^4
Methanol distribution	1.0	0.7×10^4
Liquid hydrogen distribution	0.98	1.0×10^4
Liquid methane distribution	0.99	1.0×10^4

*HV = coal heating value in 10⁶ Btu/ton.

† = transport distance in miles.

or consideration of other fuel production possibilities (e.g., coproduction of methanol and methane) could alter the numbers in Table 4-1. However, this set of numbers, tied as closely as possible to the system components on which the cost calculations are based, will serve to illustrate the characteristics of the systems under consideration.

C. Total System Energy Requirements

The calculations of energy consumption for the production and delivery of automotive fuels is analogous to the calculation of costs. That is, the ancillary energy use by each system component is obtained from Table 4-1, and divided by the product of the energy efficiencies of all the downstream components to obtain the energy use for 10^6 Btu of delivered fuel. The total system energy consumption is then the sum of the individual components, plus the energy lost from system components with conversion efficiencies less than 1.0. This sum represents the total resource energy that must be consumed to produce and deliver 10^6 Btu of automotive fuel. Mathematically, this quantity can be expressed as follows:

$$E_{\text{tot}} = 10^6 \left(\frac{1}{\prod_{i=1}^n \epsilon_i} - 1 \right) + \sum_{i=1}^n \left(\frac{E_i}{\prod_{j=1}^{i-1} \epsilon_j} \right) ; \quad (1)$$

where E_{tot} is the total energy consumed by a system for 10^6 Btu of delivered energy; n is the number of system components; ϵ_i is the efficiency of component i ; E_i is the ancillary energy requirement per 10^6 Btu output of component i ; and the symbols π and Σ have their usual meanings for multiplication and summation. In evaluating the second term the last system component--fuel distribution--is labeled $i = 1$, and the first component--coal mining--is labeled $i = n$.

The calculation of the total energy consumption for each system is carried out by the same procedure described in Chapter 3 for carrying out cost calculations. The procedure has been modified to replace all dollar costs with the ancillary energy requirements, E_i . The calculation of

total energy consumption for each system is then carried out as was the cost calculation, except that the first term in Equation (1) was also computed and added.

As was done in the dollar cost calculations, the program printed the maximum, minimum, and average energy consumption for specific pathways for coal conversion occurring in each crude production, gas production, refinery, or electric utility region.

D. Results

1. Total Energy Consumption

The results of the energy cost calculations are displayed in Figures 4-1a through 4-1c. Only the maximum and minimum energy consumption are displayed out of all the possibilities for each system. It is not necessary to display the results of all calculations because the results of interest are the sensitivities of the total system energy costs to the variations in each component. These are clearly indicated by the range of energy consumption displayed for each component, in relation to the range in total energy consumption displayed for each system.

The range of energy consumption for each component does not represent the absolute maximum and minimum consumption used in the calculations. Rather, it represents the range for the components of those system pathways for which the sum of the component energy requirements was a maximum or minimum for a particular fuel. For transportation energy consumption, however, the figures tend to represent the maximum and minimum values for transportation components. These components tend to have the most pronounced effect on the variation in total energy consumption.

Figures 4-1a through 4-1c show the flows of energy through the systems and the ancillary energy inputs required to deliver 10^6 Btu of automotive fuel or electricity. For both the ancillary inputs and the direct energy flows, two numbers are associated with each system component. The first number corresponds to the pathway with the minimum total energy consumption, and the second number corresponds to the

SYNCRUDE/GASOLINE

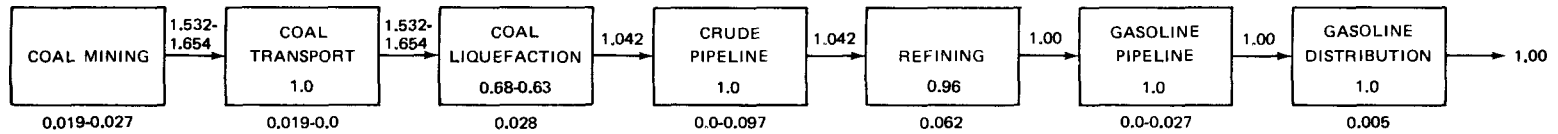

MIN MAX
 TOTAL ANCILLARY ENERGY: 0.133 - 0.246
 SYSTEM LOSSES: 0.532 - 0.654
 TOTAL ENERGY CONSUMPTION: 0.665 - 0.899

FISCHER-TROPSCH GASOLINE

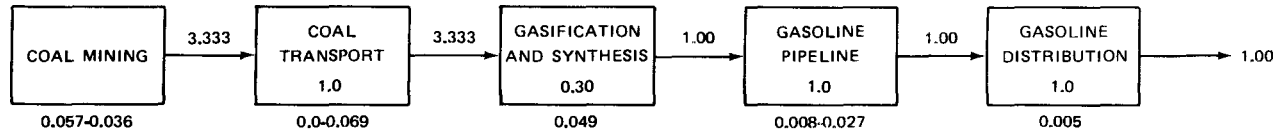

MIN MAX
 TOTAL ANCILLARY ENERGY: 0.119 - 0.186
 SYSTEM LOSSES: 2.333
 TOTAL ENERGY CONSUMPTION: 2.45 - 2.52

METHANOL

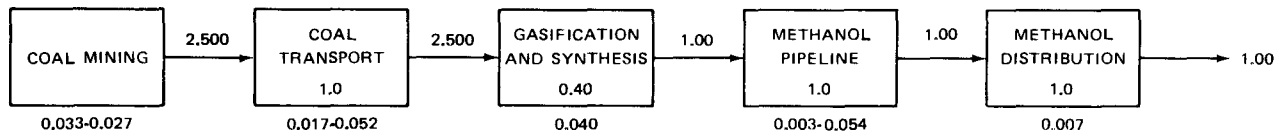

MIN MAX
 TOTAL ANCILLARY ENERGY: 0.100 - 0.180
 SYSTEM LOSSES: 1.500
 TOTAL ENERGY CONSUMPTION: 1.60 - 1.68

4-11

FIGURE 4-1a. ENERGY CONSUMPTION BY SYNTHETIC FUEL SYSTEMS

NUMBERS ABOVE THE ARROWS ARE ENERGY FLOWS; NUMBERS BELOW THE BOXES ARE ANCILLARY ENERGY REQUIREMENTS; ALL THESE NUMBERS ARE IN UNITS OF 10^6 Btu. NUMBERS WITHIN THE BOXES ARE EFFICIENCIES OF SYSTEM ELEMENTS.

METHANE

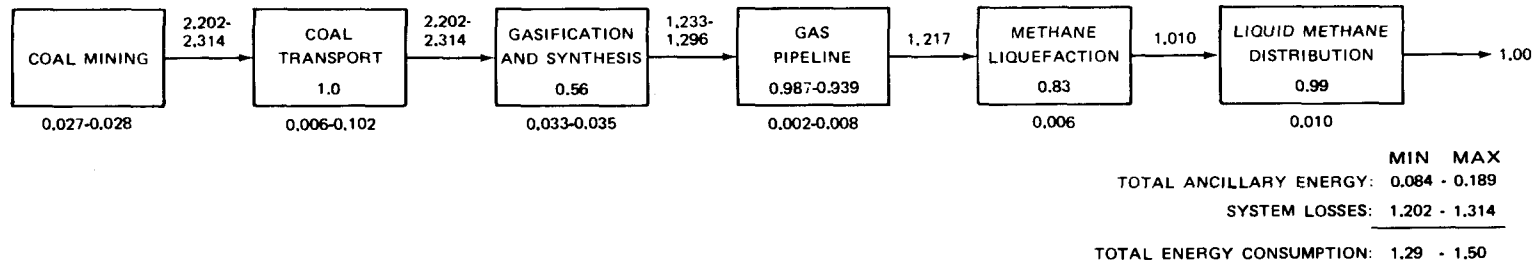

HYDROGEN

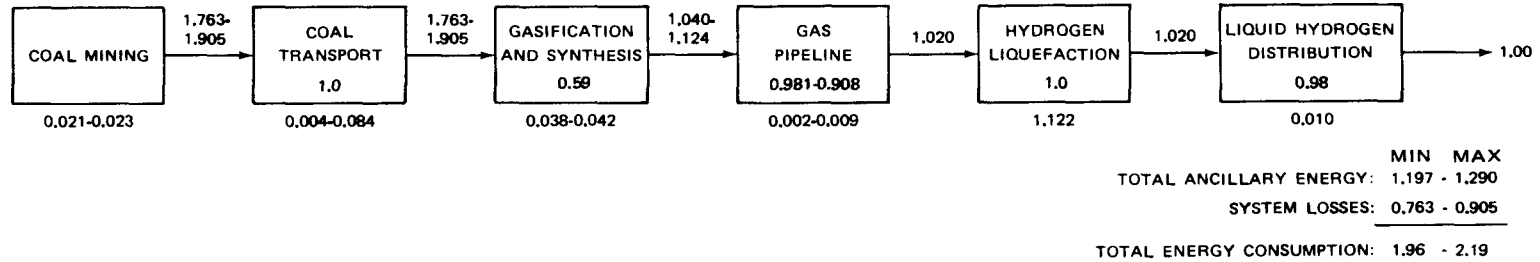

ELECTRICITY

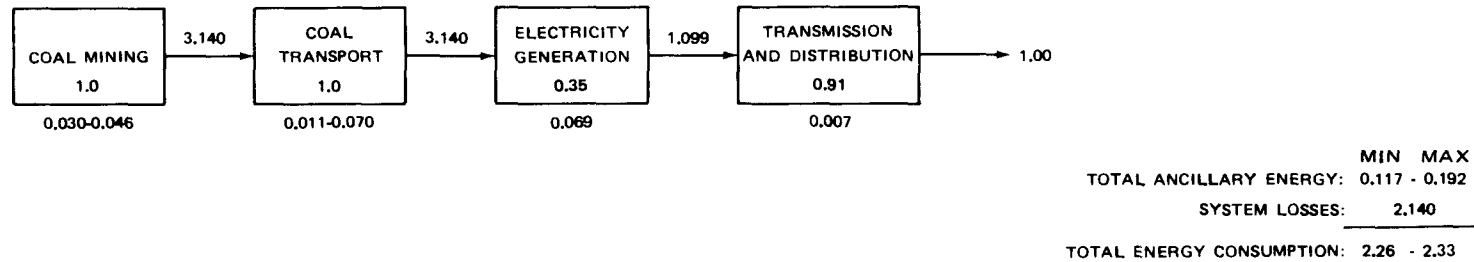
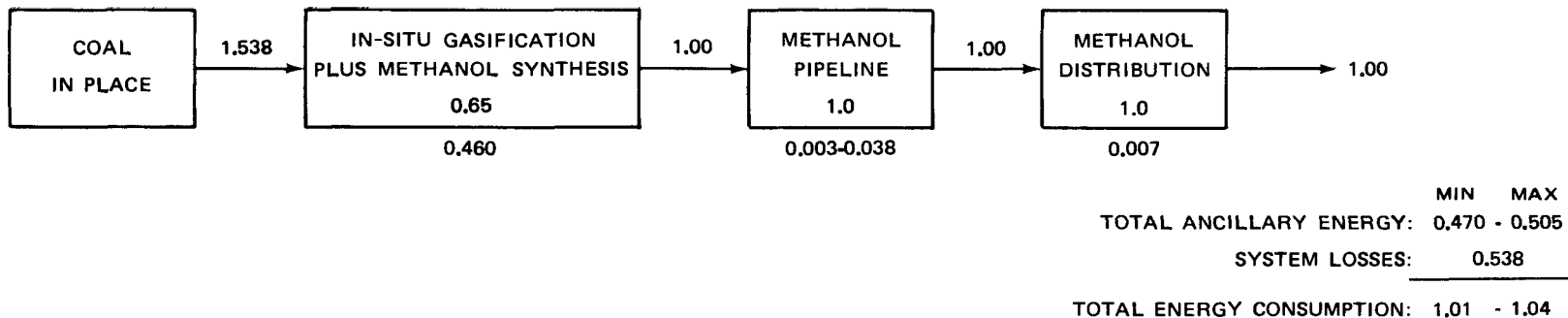

FIGURE 4-1b. ENERGY CONSUMPTION BY SYNTHETIC FUEL SYSTEMS

NUMBERS ABOVE THE ARROWS ARE ENERGY FLOWS; NUMBERS BELOW THE BOXES ARE ANCILLARY ENERGY REQUIREMENTS; ALL THESE NUMBERS ARE IN UNITS OF 10^6 Btu. NUMBERS WITHIN THE BOXES ARE EFFICIENCIES OF SYSTEM ELEMENTS.

IN SITU METHANOL



IN SITU METHANE

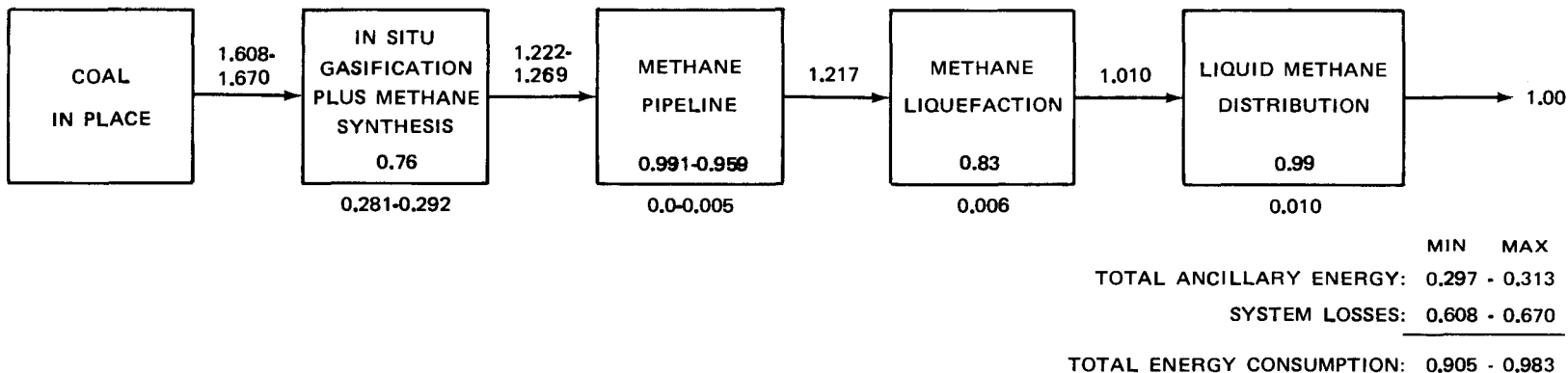

4-13

FIGURE 4-1c. ENERGY CONSUMPTION BY SYNTHETIC FUEL SYSTEMS
 NUMBERS ABOVE THE ARROWS ARE ENERGY FLOWS; NUMBERS
 BELOW THE BOXES ARE ANCILLARY ENERGY REQUIREMENTS;
 ALL THESE NUMBERS ARE IN UNITS OF 10^6 Btu. NUMBERS
 WITHIN THE BOXES ARE EFFICIENCIES OF SYSTEM ELEMENTS.

maximum. The number within each box represents the energy efficiency of that system component.

For each system, the total energy consumption is given as the sum of the total ancillary energy requirement and the total system loss for the minimum and maximum cases.

The locations of the conversion facilities and the sources of coal for the minimum and maximum energy consumption cases are shown in Table 4-2.

Table 4-2

CONVERSION PLANT LOCATIONS AND COAL SOURCES FOR
THE MINIMUM AND MAXIMUM ENERGY CONSUMPTION CASES

		<u>Plant Location</u>	<u>Coal Source</u>
Syncrude/ gasoline	Minimum	Virginia	Appalachian underground
	Maximum	Montana	Montana surface
Fischer-Tropsch gasoline	Minimum	Montana	Montana surface
	Maximum	Texas	Appalachian surface
Methanol	Minimum	Pennsylvania	Appalachian surface
	Maximum	Texas	Appalachian surface
Methane	Minimum	Illinois	Illinois surface
	Maximum	Louisiana	Illinois surface
Hydrogen	Minimum	Alabama	Appalachian surface
	Maximum	Louisiana	Illinois surface
Electricity	Minimum	Ohio	Appalachian surface
	Maximum	Minnesota	Wyoming surface

It is clear from the energy flows shown in Figures 4-1a through 4-1c that the coal conversion components represent the largest portion of overall energy consumption, ranging from 40 to 97% of the total. The exception is the hydrogen system; hydrogen liquefaction consumes more than 50% of the total, compared with 38% for coal conversion.

The contribution of coal and products transportation to the system totals varies; it ranges from less than 1% to nearly 15%.

This range indicates the influence of the varying locations in the calculations.

The sensitivity of total energy consumption to coal mining is low, as expected; coal mining energy requirements contribute 1 to 2% of the total.

Secondary conversions such as refining and liquefaction of gases can contribute significantly to total energy consumption. They represent about 15% of the total for syncrude/gasoline and methane.

The contribution of fuel distribution is uniformly small.

Figure 4-2 summarizes the energy consumption for each system and shows the variation in total energy consumption between the minimum and maximum cases. For purposes of comparison, a comparable figure is shown for the conventional domestic petroleum case. The conventional petroleum result is based on national statistics and therefore does not display a minimum/maximum variation. It is clear from Figure 4-2 that any coal-based automotive fuel option will consume considerably more resource energy than the conventional petroleum system. Coal will constitute much of the additional fuel consumed. Compared with petroleum, coal is an abundant resource. However, the large increase in energy consumption over the conventional petroleum case indicates the greatly expanded energy resource production, conversion, and transportation activities that must accompany any conversion from a petroleum-based to a coal-based transportation system.

Note that although the in-situ methane and methanol options appear attractive in relation to most others, the coal-resource base suitable for these technologies tends to differ considerably from that of the others. This is especially true of western coal, whose many deep thick seams are not suitable for recovery by conventional mining methods. However, should in-situ gasification prove successful, it may be attractive economically and energetically to provide fuels through application of this technology to seams normally accessible to conventional underground mining. This would eliminate all mining and a portion of the above-ground conversion facilities. Typically, many factors would

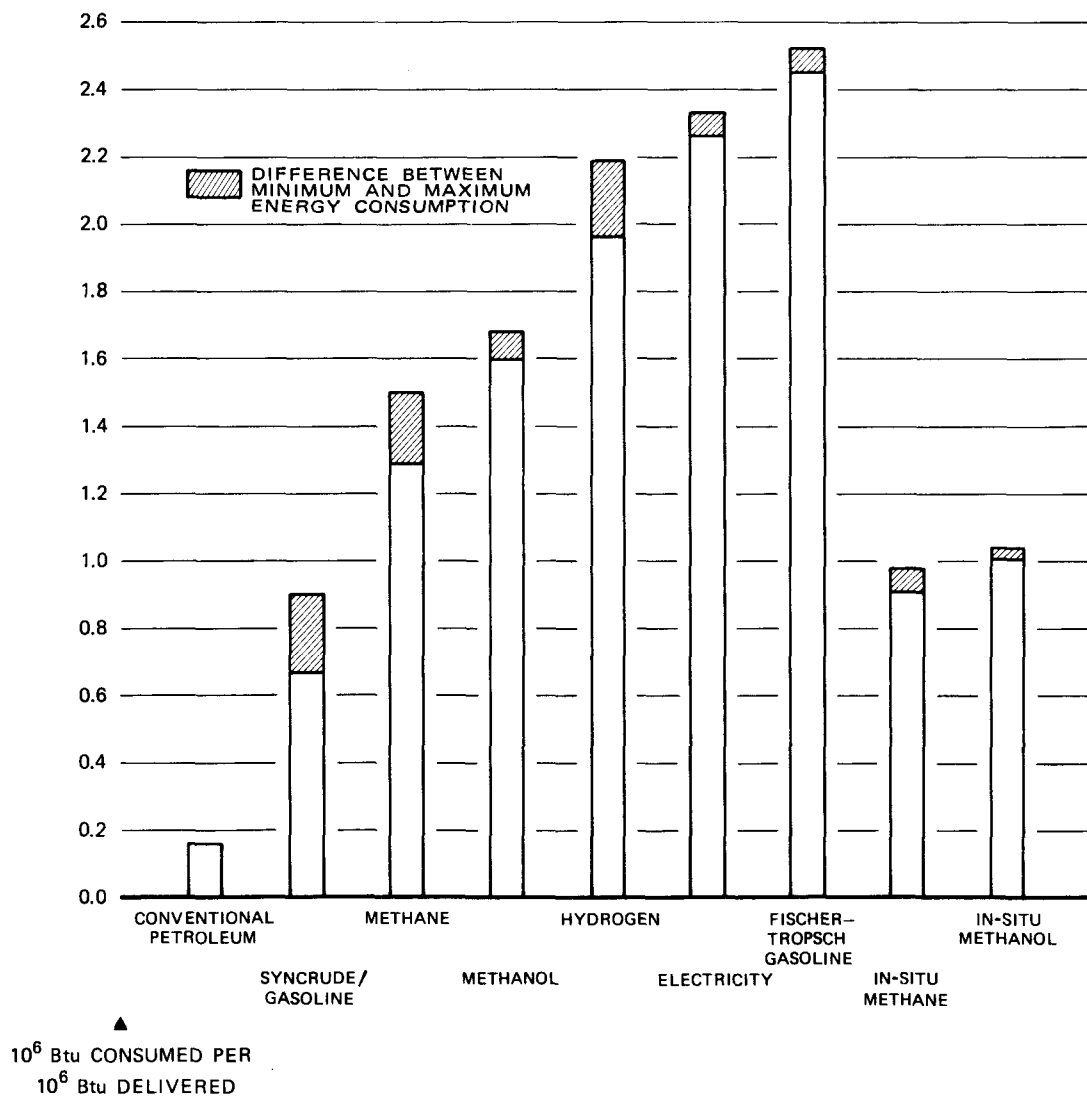

FIGURE 4-2. ENERGY CONSUMPTION BY AUTOMOTIVE ENERGY SUPPLY SYSTEMS

influence this choice, including site-related factors, environmental considerations, type of fuel desired, and the like.

2. Automotive Efficiency Effects

Because the primary function of the energy systems under consideration is to fuel automobiles, the total energy consumption must be expressed in terms of the specific end-use. In this case, the appropriate parameter is vehicle-miles of transportation. As discussed in Chapter 3, the efficiency of fuel use may vary considerably from one vehicle to the next, resulting in relative energy consumption figures considerably different from those shown in Figure 4-2.

In Figure 4-3, the vehicle energy efficiencies presented in Chapter 3 have been used to calculate the total energy required to provide one vehicle-mile of transportation, as a function of vehicle energy consumption. The total energy requirement equals the energy consumed by the vehicle, plus the energy consumed in producing and delivering this energy. As in Chapter 3, the reference case is a conventional subcompact automobile achieving a fuel economy of 30 mpg (gasoline) and meeting pollution control requirements.

The straight line plots in Figure 4-3 are based on the average total energy consumption for each fuel type. Where these lines intersect with the vehicle propulsion energy requirements, a vertical line indicates the range of total energy requirements corresponding to the minimum and maximum energy consumption shown in Figure 4-2.

As Figure 4-3 indicates, the syncrude/gasoline-powered vehicle loses its energy advantage when compared with an advanced battery-powered electric car on a Btu/mi basis. The total energy requirement for the electric car is about two-thirds that of the conventional automobile. On the other hand, among the synthetic fuel options, syncrude/gasoline is energetically superior, even allowing for considerable engine efficiency improvements for hydrogen, methane, and methanol-powered vehicles. Energetically, Fischer-Tropsch gasoline is the worst option.

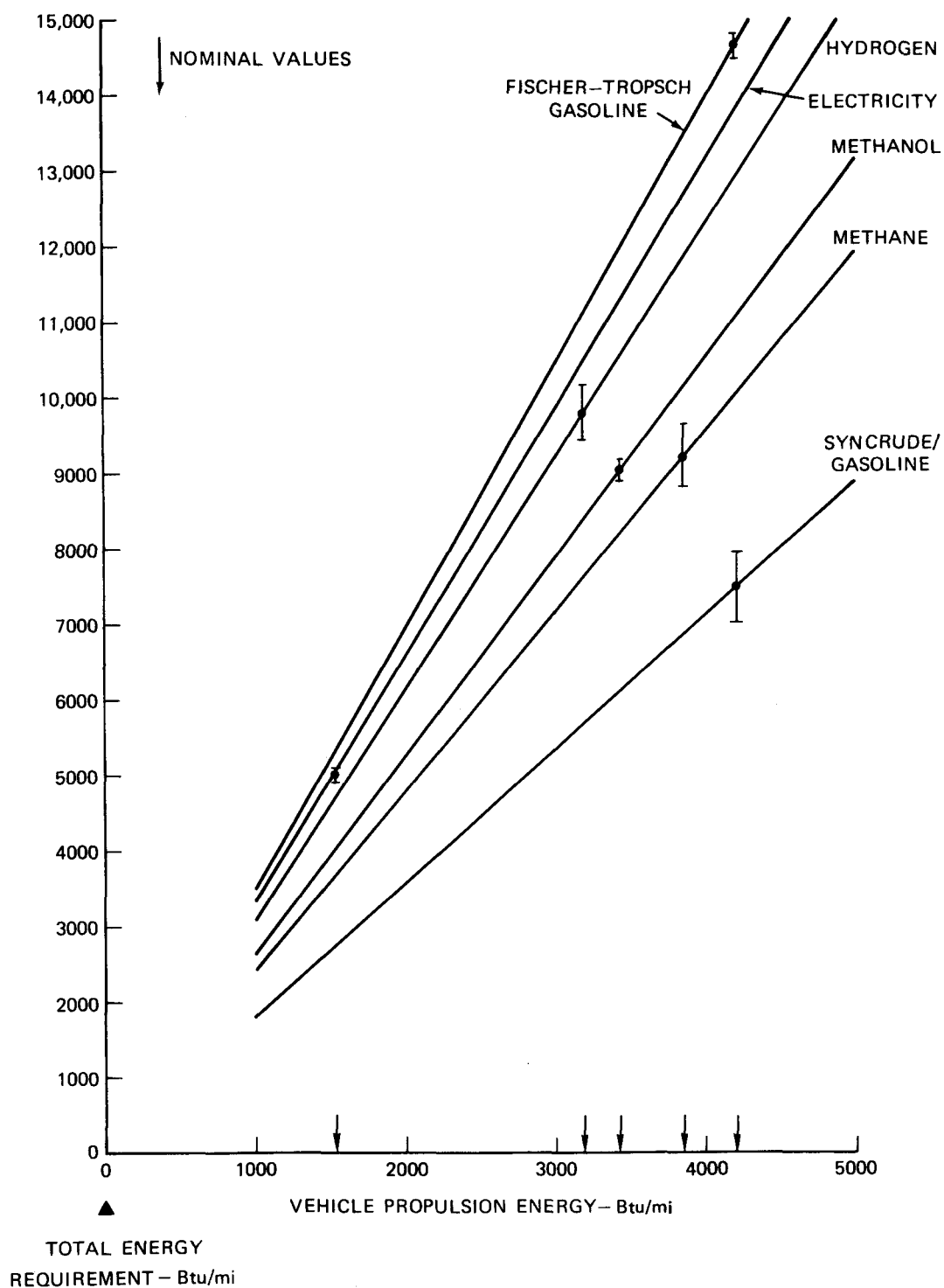

FIGURE 4-3. TOTAL ENERGY REQUIREMENTS FOR AUTOMOTIVE TRANSPORTATION

The hydrogen, methane, and methanol options fall within a narrow range of total energy consumption (9,000 to 10,000 Btu/mi) and must be considered essentially equivalent. For these options to be energetically competitive with syncrude gasoline, engine efficiency improvements on the order of 25% beyond the efficiencies shown in Figure 4-3 would be required.

Although not shown in Figure 4-3, the in-situ methane and methanol options would have total energy requirements in the range of the syncrude/gasoline option.

REFERENCES FOR CHAPTER 4

1. For more detailed discussion of this method see "Report of the NSF-Stanford Workshop on Net Energy Analysis," The Institute for Energy Studies, Stanford University, and TRW Systems Group (December 1975).
2. R. A. Herendeen and C. W. Bullard, "Energy Costs of Goods and Services, 1963 and 1967," University of Illinois Center for Advanced Computation Document No. 140 (November 1974).
3. For an exposition of the Odum approach, see M. W. Gilliland, "Energy Analysis and Public Policy," Science, 189, 1051 (1975).
4. E. M. Dickson, et al., "Synthetic Liquid Fuels Development: Assessment of Critical Factors," U.S. Energy Research and Development Administration, ERDA 76-129/2 (1976).

Chapter 5

COMPARISON OF ENERGY AND ECONOMIC RESULTS

A. Summary of Results

To facilitate comparisons of the fuel costs and energy consumption calculated in the two previous chapters, the results of the eight systems analyzed have been displayed in parallel in Figures 5-1 to 5-8. The dollar costs at the left of each figure are shown on a "value added" basis. The cost of each system component is referred to the unit (10^6 Btu) of delivered energy. When there is a range of costs, the number on the left refers to the minimum (total) cost case, as determined by the computer model calculations, and the number on the right refers to the maximum (total) cost case. The component costs are added to give the total minimum and maximum automotive energy costs shown on the bottom line.

On the right of the figures, the results of the calculations of energy consumption are shown. These numbers are analogous to the dollar cost figures in terms of the maximum and minimum cases, and in terms of the additive nature of the component energy consumption values. Unlike Figures 4-1a through 4-1c, however, in which direct energy flows and ancillary energy consumption were displayed independently, only the total energy consumption at each stage is displayed in Figures 5-1 through 5-8. The total energy consumption equals the ancillary energy consumption, plus the energy conversion loss for that component. Both figures are referred to 10^6 Btu of delivered automotive fuel.

Note that the system pathways for which energy consumption figures are shown are not necessarily the same as those for which dollar costs are shown. In general, the pathways resulting in minimum or maximum cost have differed from those that lead to minimum or maximum energy consumption.

ECONOMIC (\$/10 ⁶ Btu FUEL)			ENERGY (10 ⁶ Btu/10 ⁶ Btu FUEL)	
MINIMUM	MAXIMUM		MINIMUM	MAXIMUM
0.47	0.69	COAL MINING	0.019	0.027
0.00	0.52	COAL TRANSPORT	0.019	0.000
	2.71	COAL LIQUEFACTION	0.518	0.640
0.01	0.06	SYNCRUDE PIPELINE	0.000	0.097
0.97	1.04	REFINERY		0.104
0.00	0.17	GASOLINE PIPELINE	0.000	0.027
0.97	1.08	GASOLINE DISTRIBUTION		0.005
TOTAL:			TOTAL:	
5.10	6.30	1.00 × 10 ⁶ Btu	0.67	0.90

FIGURE 5-1. ENERGY-ECONOMIC COMPARISON: SYNCRUDE/GASOLINE

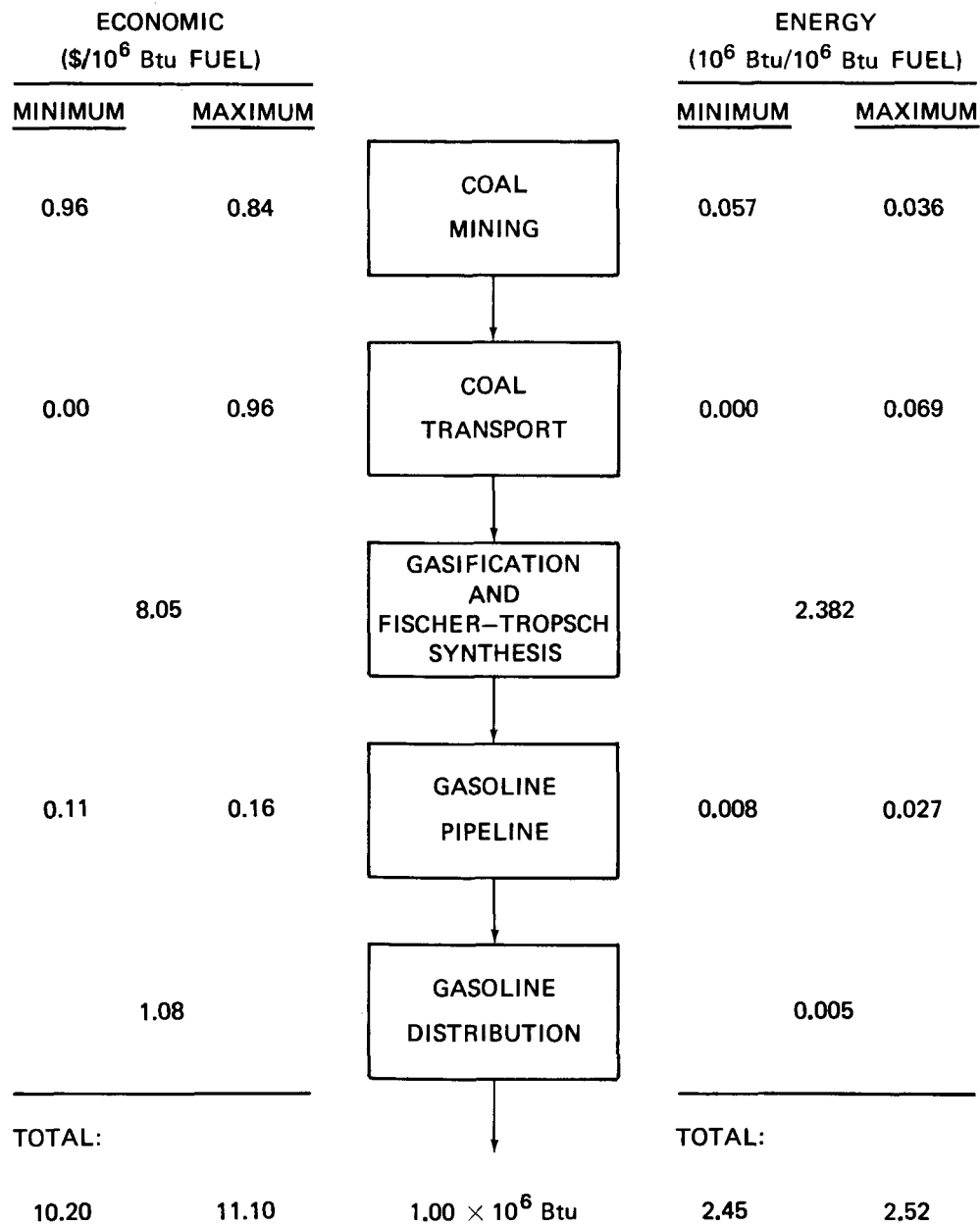

FIGURE 5-2. ENERGY-ECONOMIC COMPARISON: FISCHER-TROPSCH GASOLINE

ECONOMIC (\$/10 ⁶ Btu FUEL)			ENERGY (10 ⁶ Btu/10 ⁶ Btu FUEL)	
<u>MINIMUM</u>	<u>MAXIMUM</u>		<u>MINIMUM</u>	<u>MAXIMUM</u>
0.72	0.63	COAL MINING	0.033	0.027
0.00	0.72	COAL TRANSPORT	0.017	0.052
	6.00	GASIFICATION AND METHANOL SYNTHESIS		1.540
0.14	0.37	METHANOL PIPELINE	0.003	0.054
	2.03	METHANOL DISTRIBUTION		0.007
<hr/>			<hr/>	
TOTAL:			TOTAL:	
8.90	9.80	1.00 × 10 ⁶ Btu	1.60	1.68

FIGURE 5-3. ENERGY-ECONOMIC COMPARISON: METHANOL

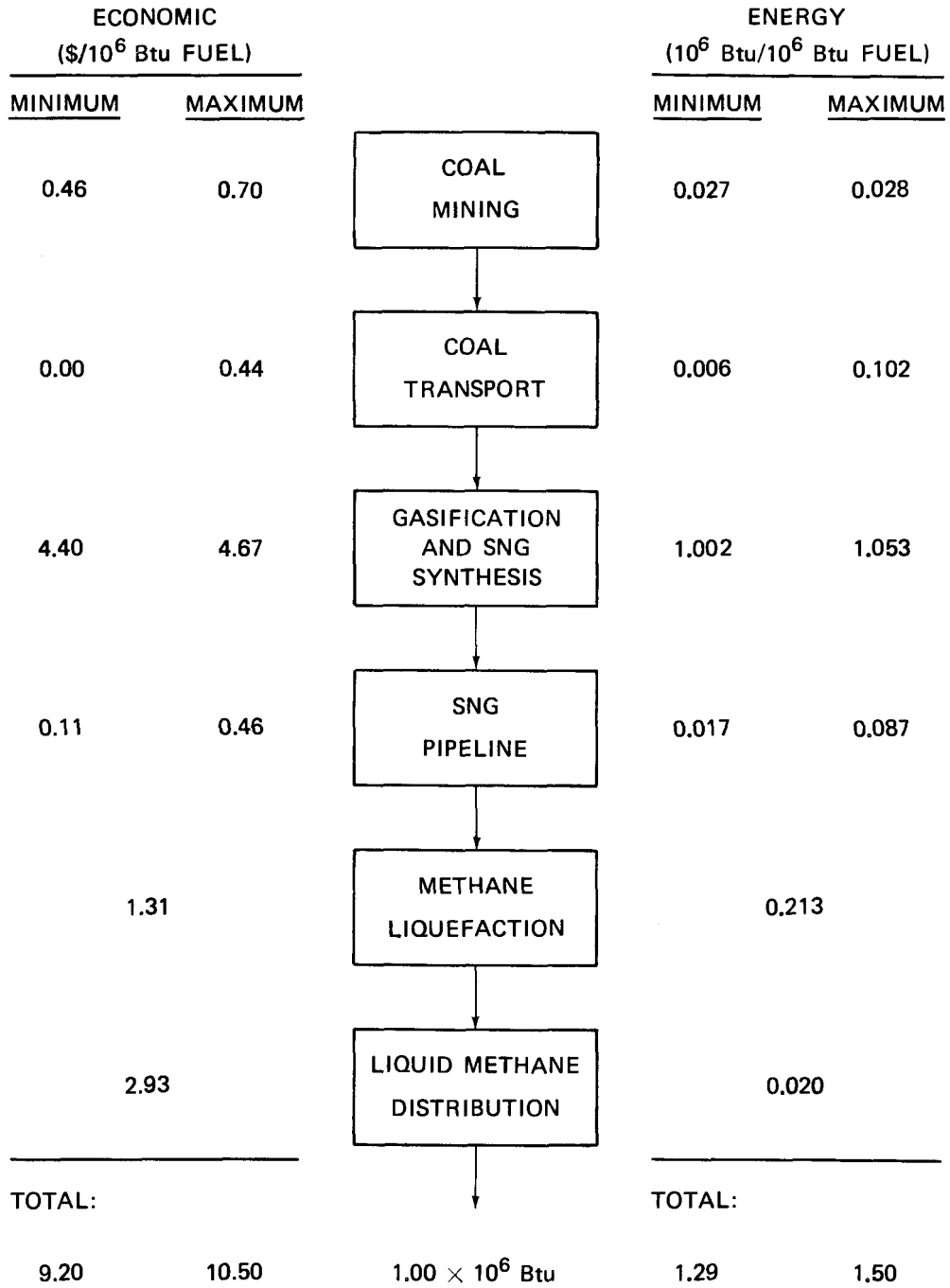

FIGURE 5-4. ENERGY-ECONOMIC COMPARISON: METHANE

ECONOMIC (\$/10 ⁶ Btu FUEL)			ENERGY (10 ⁶ Btu/10 ⁶ Btu FUEL)	
<u>MINIMUM</u>	<u>MAXIMUM</u>		<u>MINIMUM</u>	<u>MAXIMUM</u>
0.51	0.49	COAL MINING	0.021	0.023
0.20	0.55	COAL TRANSPORT	0.004	0.084
3.27	3.56	GASIFICATION AND HYDROGEN SYNTHESIS	0.761	0.822
0.13	0.97	HYDROGEN PIPELINE	0.022	0.112
	2.76	HYDROGEN LIQUEFACTION		1.122
4.34	4.70	LIQUID HYDROGEN DISTRIBUTION		0.030
<hr/>			<hr/>	
TOTAL:			TOTAL :	
11.20	13.00	1.00 × 10 ⁶ Btu	1.96	2.19

FIGURE 5-5. ENERGY-ECONOMIC COMPARISON: HYDROGEN

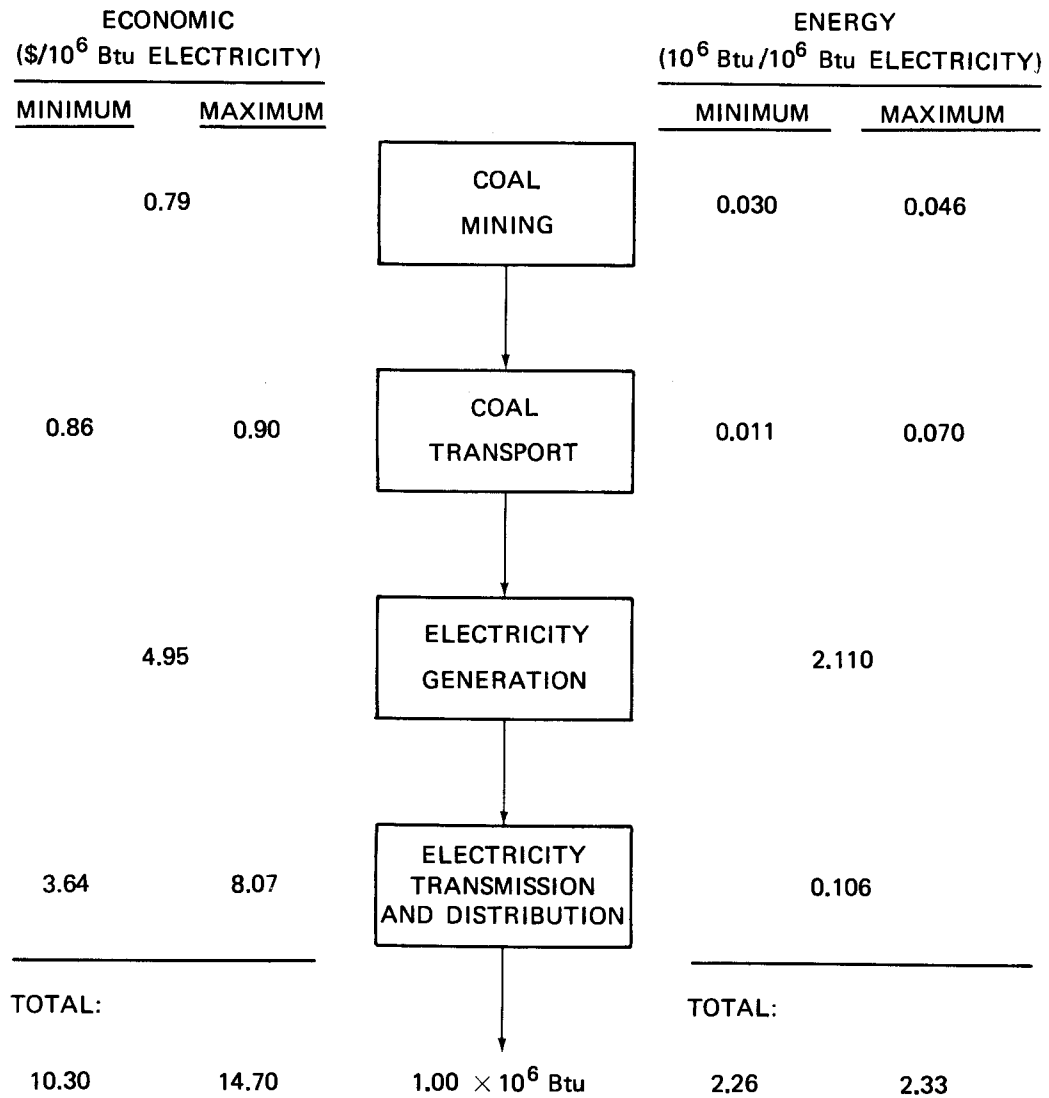

FIGURE 5-6. ENERGY-ECONOMIC COMPARISON: ELECTRICITY

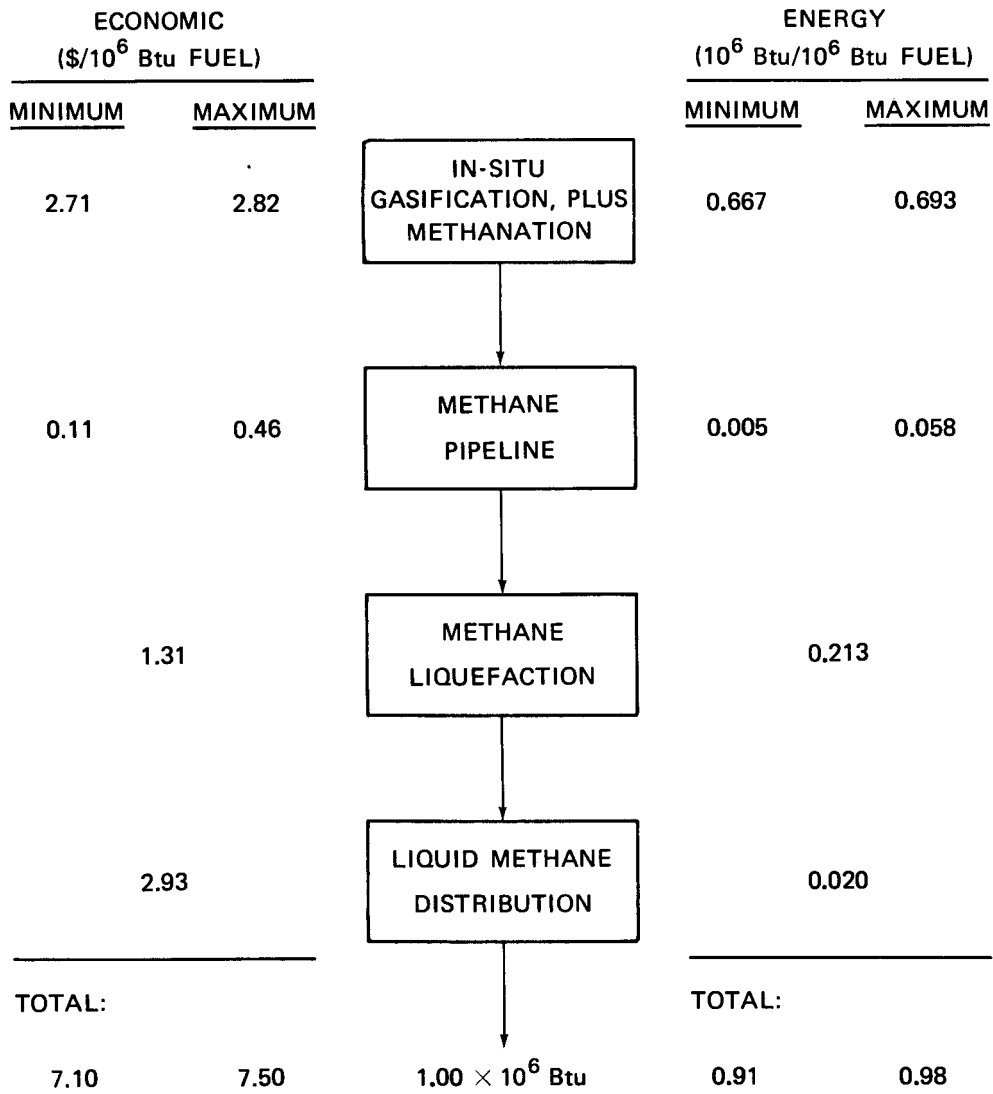

FIGURE 5-7. ENERGY-ECONOMIC COMPARISON: IN-SITU METHANE

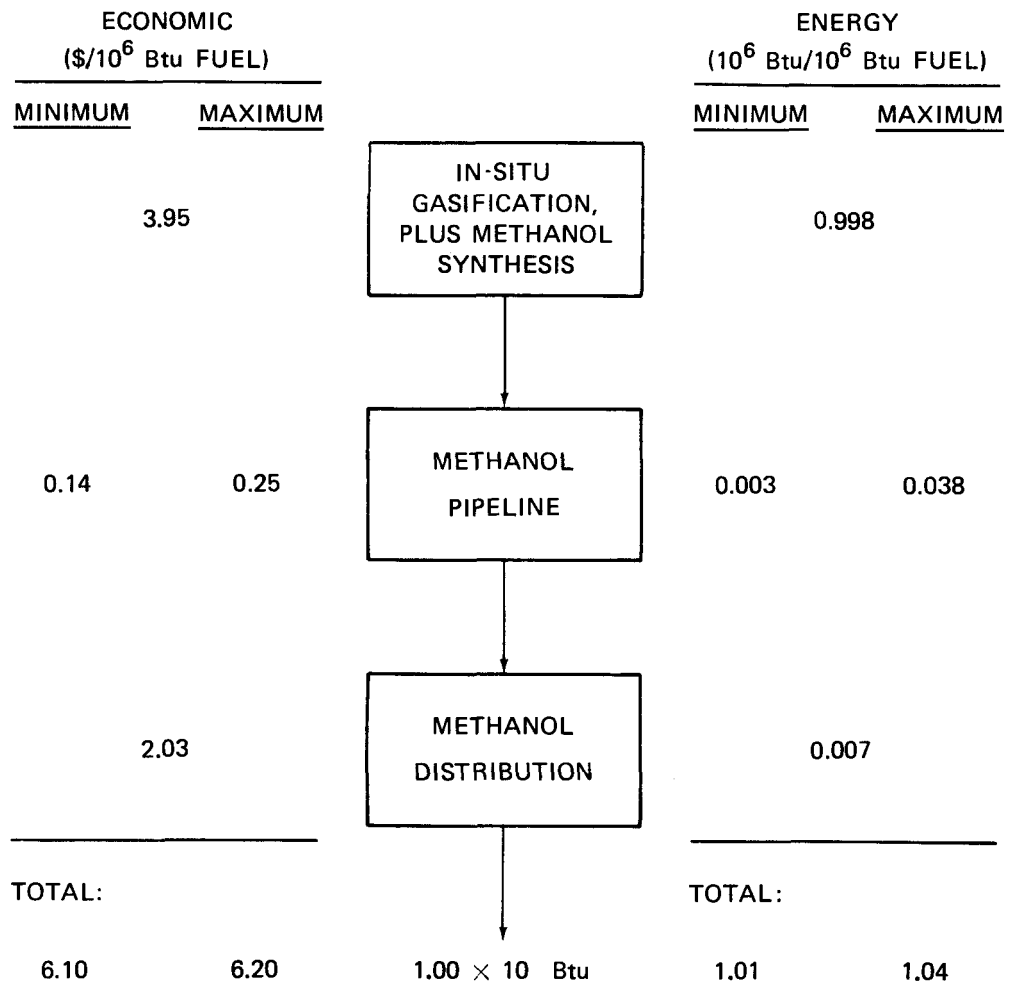

FIGURE 5-8. ENERGY-ECONOMIC COMPARISON: IN-SITU METHANOL

Examination of Figures 5-1 through 5-8 reveals interesting parallels between the consumption of energy by various system components and the corresponding costs associated with those components. In general, the most energy-consumptive system components are those that are also the most costly. For example, in the syncrude/gasoline system, two components--coal liquefaction and refining--contribute 60 to 72% of the delivered fuel cost; in terms of total energy consumption, these same components contribute 83 to 93%. Similar conclusions hold true for the other systems. The major exceptions are the fuel distribution components for which the costs are enormously out of proportion to the energy consumption.

Components that consume large amounts of energy do so because the energy form undergoes severe chemical or physical transformation as in gasifying coal, refining crude petroleum, or liquefying gaseous hydrogen. In terms of costs, these processes require large amounts of sophisticated equipment with high capital and operating costs. It is not surprising, therefore, that those system components that are the costliest also tend to consume the most energy.

For the exceptional case of fuel distribution, the high cost results from the large degree of handling required. The total costs include bulk fuel storage and transfer, delivery by truck, and dispensing the fuel at filling stations, as well as associated marketing costs such as advertising. Many of these activities are labor-intensive, and often expensive equipment is involved (such as that required for handling liquid methane or hydrogen). However, extreme physical or chemical transformations that require the expenditure of large quantities of energy are never involved.

Looking at other system components reveals similar trends. Coal mining, for example, a much more labor-intensive activity than coal conversion, contributes about 5 to 10% to the total cost, whereas the corresponding energy consumption figures are 1 to 3%. However, in this and other cases (with the exception of distribution) when cost and energy consumption are out of proportion to one another, the overall contributions

tend to be modest. The overwhelming tendency is for the overall system cost and energy consumption to go hand-in-hand.

B. Comparison of Costs and Energy Consumption

The preceding statement can be tested by plotting energy consumption versus cost for each energy system under consideration. Figure 5-9 displays such a plot. As a comparison case, the conventional gasoline-from-crude petroleum system is included. The coal-to-electricity system is shown with an arrow pointing to the right to indicate that this system is the only one not based on private Discounted Cash Flow (DCF) financing. Rather, it is based on utility economics, for which the recovery rate of capital is considerably less than for privately financed systems, based on about a 15% DCF rate of return. It would be fairly straightforward to calculate the electrical generation cost, based on private DCF financing, because the capital and operating costs have been specified. However, the costs of electricity transmission and distribution were taken from published information that did not break down specific capital and operating costs by region. However, based on the capital-intensive nature of both the generation and distribution portions of the system, the electricity costs shown in Figure 5-9 can be conservatively estimated to increase by at least 50% if private DCF financing were applied.

Results pictured in Figure 5-9 reinforce the notion that energy consumption tends to follow cost for synthetic automotive fuel systems. Although the variation of energy consumption with cost is not precisely a monotonically increasing function, the trend is certainly evident. When deviations from the trend (e.g., electricity and hydrogen) occur, it is generally because these systems have high-cost components--primarily distribution--that are significantly out of proportion in regard to the energy consumed. These high-cost components result from the special handling requirements of the energy form.

It would be tempting to apply the inferences present in Figure 5-9 to all types of energy systems. Such application would be futile, however, because the energy systems examined here have unique characteristics:

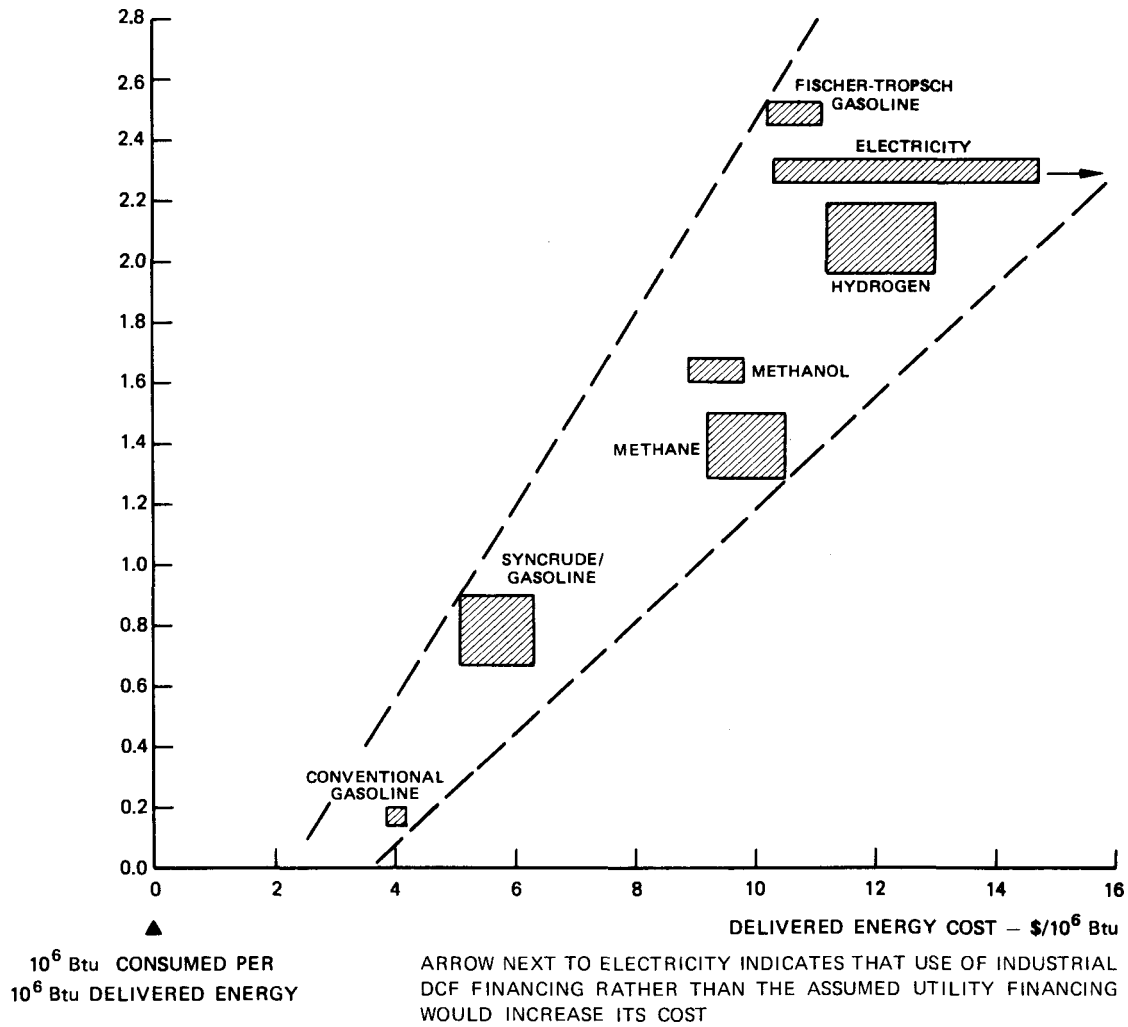

FIGURE 5-9. ENERGY CONSUMPTION VS. COST FOR AUTOMOTIVE ENERGY SUPPLY SYSTEMS

ARROW NEXT TO ELECTRICITY INDICATES THAT USE OF INDUSTRIAL DCF FINANCING RATHER THAN THE ASSUMED UTILITY FINANCING WOULD INCREASE ITS COST

Specifically, they are both capital-intensive and energy-intensive; these two characteristics derive from the severe chemical and physical processing required to convert coal into a clean, storable, high-density energy form suitable for automotive use. Other systems more heavily dependent on other types of inputs--labor, nonenergy resources, and the like--may follow totally different patterns of cost and energy consumption. Possibly, they may follow no general pattern at all. Thus, extrapolation of the trends observed in Figure 5-9 to other types of systems without careful analysis could be misleading.

C. Conclusions

The analysis in this study has pointed out the trends in costs and energy consumption for several coal-based automotive energy alternatives. The many possible variations in coal conversion sites, and in transportation and distribution pathways have been considered. The varying efficiencies with which automobiles use the energy forms have been shown to be important in judging the relative costs and energy requirements for automotive transportation.

If we were to choose the single most attractive option, the syncrude/gasoline option would rank first as the energy supply of choice for conventional automobiles. If the successful development of advanced batteries for electric cars is assumed, the electricity option appears even more attractive. However, such a choice can never be so simple, and a host of other considerations such as automobile performance, automobile cost, refueling capability, and the like, must be brought to bear before actually choosing between one automotive option and another.

We reemphasize that narrow considerations of cost and energy consumption can never be the sole basis for public and private decisions regarding future energy systems. However, for transportation decision-makers who attempt to weigh these two parameters, among others, it appears that a decision based on low cost will tend to be an energy-conservative decision as well. Thus, a transportation decision-maker concerned primarily with energy conservation need not worry that the systems he tends

to promote will be significantly more costly than others that consume more energy--at least for the capital- and energy-intensive systems considered here. Of course, systems that depend considerably less on capital and energy will have to be considered as separate instances.

APPENDICES

Appendix A

AN ALTERNATIVE APPROACH TO ENERGY ANALYSIS FOR SYNTHETIC LIQUID FUELS

A. Introduction

The calculation of energy resource consumption by energy conversion processes has usually been carried out by considering these processes in isolation from the existing energy supply network. The impacts of new processes on the energy flows through this network are never explicitly accounted for. It is possible, however, to make such an accounting by establishing the energy flows through the conventional system in the absence of the new processes, and then considering these processes as perturbations to the conventional system. The result of the calculations is an indication of the changes in energy resource consumption that would take place if a given fraction of the conventional energy supply were replaced by fuels derived from the new processes.

In the case of synthetic liquid fuels, the conventional supply system is the production and import of crude petroleum and subsequent refining into products and distribution of these products. The production of syn-fuels will induce changes in energy consumption in all these areas. The most likely result is that synfuels will replace imported petroleum, since this course of action has been expressed as a national goal.

In the cases in which some of the synfuels can be used more efficiently in a particular end-use application, this effect can be explicitly accounted for in the calculation of incremental energy resource consumption.

B. Energy Flows in the U.S. Petroleum System--1973

To provide a reference case with which to compare the production of synfuels, we have derived energy flows through the U.S. petroleum supply system in 1973. These energy flows, both direct and indirect, account for all the energy required to deliver refined petroleum products to the U.S. economy. The major sources of data are the Mineral Industry Surveys of the Bureau of Mines,¹ DOD transportation and energy statistics,² and a recent net energy study by Development Sciences, Inc.³

The flows of energy associated with this system are displayed in Figure A-1 in units of trillion Btu per year. In this figure, rectangles represent activities within the system, such as petroleum refining, and triangles represent the input of energy resources other than petroleum--coal, natural gas, and the fossil fuel equivalent of hydro and nuclear power. Horizontal arrows represent energy flows through the system, and vertical arrows represent direct and indirect inputs of energy required to operate and maintain the system. The feedback arrow issuing from the "Product Distribution" box represents the consumption of petroleum products by the various activities within the system.

We have divided the output of products from the system into "Automotive Fuels" and "Other Products" because further analysis will concentrate on automotive fuel demand as the specific end-use of interest. In 1973, the net automotive fuel demand of cars, trucks, and buses was 12,650 trillion Btu of gasoline and 950 trillion Btu of diesel fuel. Taken together, these quantities provided 1.30 trillion vehicle-miles of transportation (VMT). These figures are exclusive of the automotive fuels consumed within the petroleum supply system itself.

The energy flows in Figure A-1 are aggregated to a high degree, and have been averaged over different types of crude oil production, different modes of petroleum transport, and the like. They are based, however, on much more detailed data, which can only be summarized here.

The dashed portions of Figure A-1 indicate how liquid synfuels would be introduced into the conventional petroleum system. Syncrudes derived from coal and oil shale would be shipped to refineries for refining into

A-3

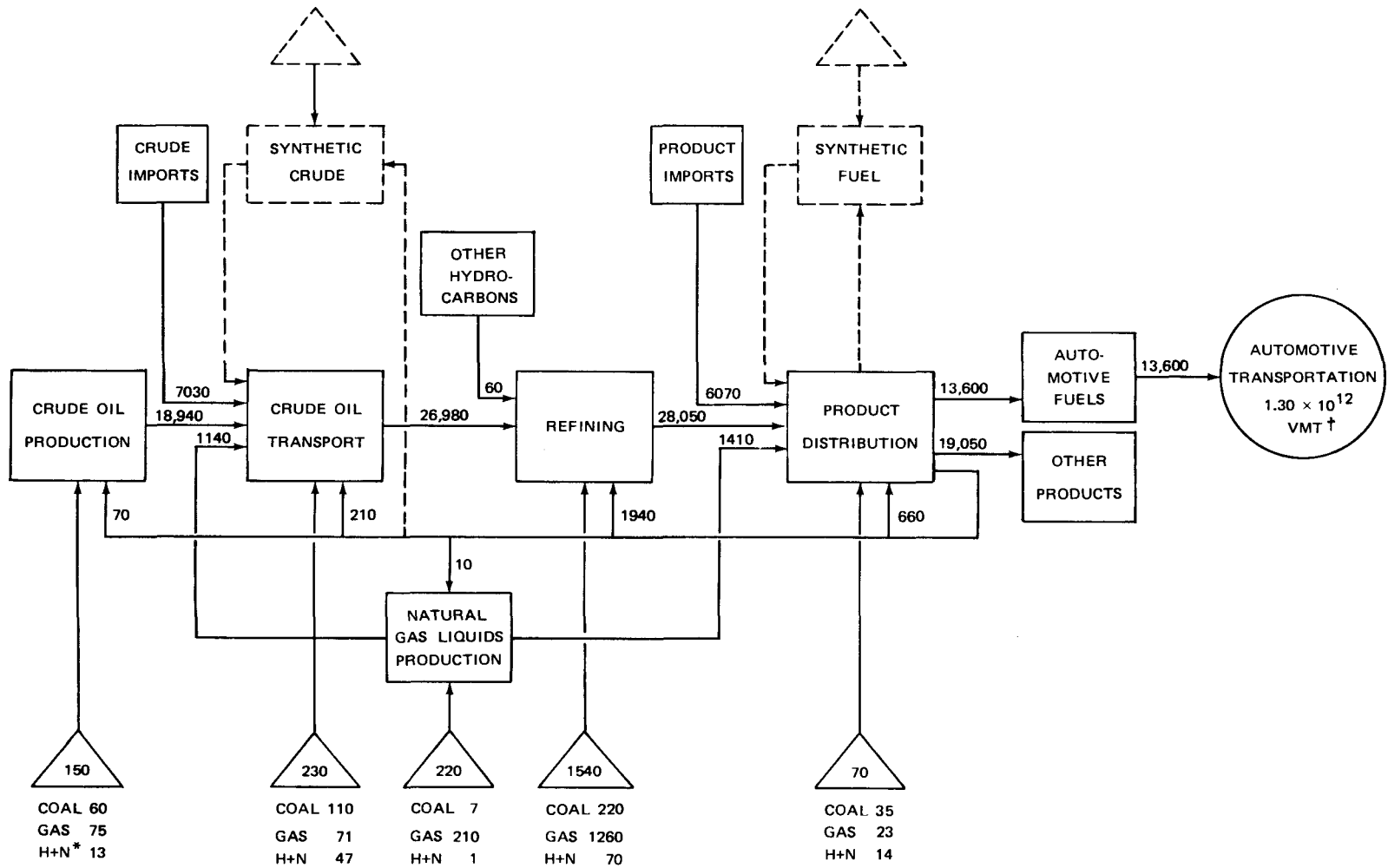

* H + N = HYDRO AND NUCLEAR POWER

† VEHICLE MILES TRAVELED

FIGURE A-1. ENERGY FLOWS IN THE U.S. PETROLEUM SUPPLY SYSTEM IN 1973 (10^{12} Btu/Yr)

various product slates. Fuels that can be used directly without refining, such as methanol derived from coal, would be introduced directly into the product distribution system. In both cases, any direct or indirect consumption of energy resources, including petroleum, would be accounted for.

Looking at only the automotive fuels component of the petroleum product slate, we can trace through the system the contributions of the various energy sources to the production of automotive fuels. To facilitate later comparisons of different synfuels with different end-use efficiencies, automotive energy consumption can be expressed as Btu/VMT. The figures for automotive energy consumption in 1973 are shown in Table A-1. Of the total of 12,020 Btu/VMT, 10,460 went directly into the fuel tanks of cars, trucks, and buses. The difference, 1560 Btu, was consumed in the production, transport, and refining of petroleum. About 52% of this indirect energy consumption was supplied by resources other than petroleum. Of the total energy consumed, 27% was supplied by imports.

C. Use of Energy Resources in Synthetic Liquid Fuel Production

To understand the changes in energy consumption that the introduction of liquid synfuels into the U.S. petroleum supply system would involve, we must first calculate the energy requirements for each synfuel technology of interest. The appropriate methods of energy accounting by which this energy consumption is computed have been described in Chapter 5 of Volume II of this series. Basically, direct fuel consumption data are obtained from engineering process analysis, whereas indirect energy consumption data are derived from cost estimates for plant construction and operation by using the energy input-output tables of Herendeen and Bullard.⁴

Energy consumption calculations have been carried out on the following technologies, based on engineering data supplied in the references noted: liquefaction of Powder River coal and Illinois coal via the H-coal process;⁵ TOSCO II oil shale retorting;⁶ Paraho oil shale retorting;⁷ Garrett modified in-situ oil shale retorting;⁸ methanol from coal via Lurgi gasification of New Mexico coal;⁹ methanol from coal via Koppers-Totzek gasification of Illinois coal;¹⁰ and methanol from coal via the Lawrence Livermore Laboratory (LLL) process for in-situ gasification of Powder River coal.¹¹

Table A-1

TOTAL CONSUMPTION OF ENERGY REQUIRED TO PROVIDE FUEL
FOR ONE VEHICLE-MILE OF AUTOMOTIVE TRANSPORTATION IN 1973

<u>Energy Source</u>	<u>Btu</u>
Domestic Crude and NGL [*]	7,960
Imported Crude	2,680
Imported Petroleum Products	570
Coal	160
Natural Gas	600
Hydro and Nuclear	<u>50</u>
Total	12,020
Direct Fuel Consumption	10,460

^{*}NGL = Natural Gas Liquids

The results of the calculations for each technology are presented in Table A-2, which shows the quantity of each type of energy resource required to produce 1 Btu of liquid synfuel. The numbers include mining of the coal or oil shale, and upgrading of the raw shale oil. The coal conversion facilities are assumed to be located at the minemouth. Energy consumption for transporting the product from the plant has not been included. Note that totals in the last column are not net energy ratios but simply ratios of total energy "in" to energy "out." (We present the results in this way to avoid the confusion that often arises when net energy ratios are presented.)

There are several reasons for the variations of energy requirements among technologies producing the same product. For oil shale, much of the variation is due to the different grades of shale assumed for each technology. For methanol, the in-situ process consumes considerably less coal as fuel than above ground gasification, even though the original fuel requirement contained in the LLL¹¹ estimate was too low and was doubled for this calculation. In addition, the estimates of the efficiency of in-situ gasification may be somewhat optimistic.

D. Incremental Transportation Energy Requirements for Use of Synthetic Fuels

Although the numbers in Table A-2 may be of some use in themselves, they do not readily indicate how consumption of energy resources would change if synfuels were introduced into the U.S. petroleum supply system. Using the scheme shown in Figure A-1 along with the energy requirements in Table A-2 we can calculate the changes in energy consumption induced by synfuel production. The major assumptions that have been made for this calculation are:

- Automotive transportation demand (total VMT) remains constant, as does the demand for other petroleum products
- The production of syncrude displaces imported crude oil
- The production of methanol displaces gasoline derived from imported crude oil, ultimately displacing imported crude.

Table A-2

TOTAL ENERGY RESOURCE COMMITMENT
REQUIRED TO PRODUCE 1 BTU OF SYNTHETIC
LIQUID FUEL

Technology	Energy Resource (Btu)				Total
	Coal	Crude Oil and Gas	Hydro and Nuclear	Oil Shale	
Syncrude from coal					
H-Coal process					
Powder River Coal	1.586	0.056	0.018	NA*	1.66
Illinois Coal	1.475	0.051	0.016	NA	1.54
Syncrude from Oil Shale					
Tosco II (35 gal/ton)	0.052	0.048	0.020	1.309	1.43
Paraho (28 gal/ton)	0.008	0.014	0.001	1.440	1.46
Modified in-situ (20 gal/ton)	0.007	0.014	0.001	1.728	1.75
Methanol from coal					
Lurgi gasification					
New Mexico Coal	2.467	0.042	0.007	NA	2.52
Koppers-Totzek Gasification					
Illinois Coal	2.581	0.051	0.007	NA	2.64
LLL In-Situ Gasification					
Powder River Coal	1.970	0.035	0.003	NA	2.01

*NA = not applicable

A parameter must also be chosen to indicate the degree increased synfuel supply replaces fuels derived from conventional sources--imports in this case. Because the end-use here is automotive transportation, the most useful parameter is the fraction of automotive transportation provided by methanol or by gasoline and diesel fuel derived from syncrude. The results of the calculation can then be expressed as the incremental consumption of each type of energy resource required to replace a fraction, F , of automotive fuel demand by synfuels. The incremental energy requirements are expressed as coefficients of the fraction F , and are expressed in Btu/VMT. The coefficients contain all positive or negative changes in energy consumption that would occur in the petroleum supply system, relative to the base year, with the introduction of synfuels. These include changes in the amount of imported crude oil, changes in crude oil transportation energy requirements, and so forth. Thus, to obtain the total energy requirements for a given value of F , the coefficients are multiplied by F and added to the base case energy requirements.

Tables A-3a and A-3b display the incremental energy requirement coefficients for each energy resource, for the eight technologies under consideration, along with the total incremental energy requirement coefficients. In addition, the total requirement for the use of domestic resources to supply automotive transportation via synfuels is tabulated.

In Table A-3b, the calculations for methanol assume that methanol can be burned in a properly designed internal combustion engine with an efficiency 1.33 times that of gasoline. This figure reflects quantitatively a recent assessment of methanol-fueled engines by LLL.¹² (In other words, 0.75 Btu of methanol can substitute for 1 Btu of gasoline.)

By assigning a specific value to F , we can visualize the additional demands on domestic resources required by reducing dependence of automotive transportation on imported petroleum through the use of synfuels. For example, using a value of $F = 0.1$ (10 percent of automotive fuel demand supplied by synfuels), the total energy consumption per vehicle-mile of transportation would increase by 4 to 8 percent; the consumption of domestic

Table A-3a

INCREMENTAL ENERGY REQUIRED TO REPLACE A FRACTION, F, OF AUTOMOTIVE
 FUEL DEMAND WITH SYNTHETIC LIQUIDS DERIVED FROM COAL AND OIL SHALE--BASE YEAR 1973
 (Units: Btu/VMT)

Energy Source	Synchrude					
	Base Case	Oil Shale (Tosco II)	Oil Shale (Paraho)	Oil Shale (In-Situ)	Powder River Coal (H-Coal)	Illinois Coal (H-Coal)
Domestic Crude and NGL**	7,960	0	0	0	0	0
Imported Crude	2,680	-10,620F [†]	-10,800F	-10,800F	-10,570F	-10,600F
Imported Petroleum Products	570	0	0	0	0	0
Coal	160	+ 610F	+ 130F	+ 120F	+17,390F	+16,150F
Oil Shale	0	+14,290F	+15,730F	+18,900F	0	0
Natural Gas	600	+ 330F	+ 130F	+ 130F	+ 380F	+ 360F
Hydro and Nuclear	50	+ 240F	+ 30F	+ 30F	+ 220F	+ 180F
Total	12,020	+ 4,850F	+ 5,210F	+ 8,350F	+ 7,410F	+ 6,090F
Total Domestic Resources	8,770	+15,470F	+16,010F	+19,140F	+17,980F	+16,690F

* VMT = Vehicle Mile of Transportation

** NGL = Natural Gas Liquids

[†] F = Fraction of automotive demand replaced by synfuel

Table A-3b

INCREMENTAL ENERGY REQUIRED TO REPLACE A FRACTION, F, OF AUTOMOTIVE
 FUEL DEMAND WITH SYNTHETIC LIQUIDS DERIVED FROM COAL AND OIL SHALE--BASE YEAR 1973
 (Units:Btu/VMT*)

Energy Source	Methanol		
	New Mexico Coal (Lurgi)	Illinois Coal (Koppers-Totzek)	Powder River Coal (In-situ)
Domestic crude and NGL**	0	0	0
Imported crude	-10,740F [†]	-10,700F	-10,790F
Imported petroleum products	0	0	0
Coal	+19,480F	+20,140F	+15,350F
Oil shale	0	0	0
Natural gas	- 350F	- 320F	- 370F
Hydro and nuclear	+ 20F	+ 20F	- 10F
Total	+ 8,680F	+ 9,140F	+ 4,180F
Total domestic resources	+19,420F	+19,840F	+14,970F

* VMT = vehicle mile of transportation

** NGL = natural gas liquids

[†]F = fraction of automotive demand replaced by synfuel

energy resources would increase by 17 to 23 percent.*

E. Conclusions

The calculation of incremental resource energy requirements summarized in Tables 3a and 3b indicates that recovery of the higher grades of oil shale results in the lowest consumption of domestic energy resources of all the synfuel options. The conversion of coal to syncrude is second lowest, and the conversion of coal to methanol is the highest (with the exception of in-situ recovery), even when increased end-use efficiency is taken into account. The production of methanol from coal gasified in-situ compares quite favorably with other options. However, this process is still in the conceptual stage, and much experimental work is needed before actual operating efficiencies are known. If the favorable conversion and end-use efficiencies in Table 3a can be achieved, then the methanol route may prove attractive for coal reserves that are not efficiently recoverable by mining.

The efficiency of using in-situ recovery of lower grade oil shale resources is not as attractive as that of other syncrude options. However, the advantages of recovering a large part of the oil shale resource not otherwise recoverable should be a major consideration.

One should not imagine that these calculations are sufficient to determine the most attractive alternative for providing automotive fuels. Each option will have its own set of economic costs, environmental impacts and technical problems that will contribute to its ultimate acceptability. However, the calculations do provide an assessment of the ways in which domestic energy resource production will be affected if any of the options is pursued. This assessment is realistic in the sense that it recognizes the prior existence of a large-scale petroleum supply network with which synfuel production must interface.

* Note that the use of methanol as an automotive fuel would actually decrease the consumption of natural gas, due primarily to the decrease in refinery fuel consumption.

The method of analysis applied in this Appendix can also be applied to the calculation of economic costs and environmental impacts associated with synfuel production. Such analysis could lead to a more comprehensive assessment of the relative attractiveness of these technologies.

REFERENCES FOR APPENDIX A

1. "Crude Petroleum, Petroleum Products and Natural Gas Liquids: 1973," U.S. Bureau of Mines, Mineral Industry Surveys Annual Petroleum Statement (1975).
2. "Summary of National Transportation Statistics," U.S. Department of Transportation, Report DOT-TSC-OST-74-8, and Energy Statistics, Report DOT-TSC-OST-74-12 (1974).
3. A. J. Frabetti et al., "A Study to Develop Energy Estimates of Merit for Selected Fuel Technologies," Development Sciences, Inc. (1975).
4. R. A. Herendeen and C. W. Bullard, "Energy Cost of Goods and Services, 1963 and 1967," University of Illinois Center for Advanced Computation Document 140 (1974).
5. R. L. Goen et al., "Synthetic Petroleum for Department of Defense Use," Stanford Research Institute (1974).
6. "An Environmental Impact Analysis for a Shale Oil Complex at Parachute Creek, Colorado," Colony Development Operation (1974).
7. S. K. Kunchal, "Energy Requirements in an Oil Shale Industry: Based on Paraho's Direct Combustion Retorting Process," Quarterly of the Colorado School of Mines: Proceedings of the Eighth Oil Shale Symposium, 70(3), 21 (July 19, 1975).
8. C. Y. Cha and D. E. Garrett, "Energy Efficiency of the Garrett In-Situ Oil Shale Process," Quarterly of the Colorado School of Mines: Proceedings of the Eighth Oil Shale Symposium 70(3), 31 (July 1975).
9. F. K. Chan, "A SASOL Type Process for Gasoline, Methanol, SNG, and Low-Btu Gas from Coal," U.S. Environmental Protection Agency Report EPA-650/2-74-072 (1974).
10. J. Pangborn et al., "Alternative Fuels for Automotive Transportation," U.S. Environmental Protection Agency, EPA-460/3-74-012c (1974).
11. A. Pasternak, "Methyl Alcohol Production by In-Situ Coal Gasification," Lawrence Livermore Laboratory, UCRL-51600 (1974).
12. H. C. Vantine et al., "The Methanol Engine: A Transportation Strategy for the Post-Petroleum Era," Lawrence Livermore Laboratory, UCIR-961 (1975).

Appendix B

ENERGY AND ECONOMIC EVALUATION OF ELECTRIC VEHICLES AND SYN-FUEL-POWERED VEHICLES*

A. Costs of Automotive Transportation

Table B-1 presents the 1975 costs of the synfuel system (syncrude/gasoline) as they appear to the consumer of the product--the owner and operator of the automobile. Table B-2 presents similar data for the electric automobile. If the synfuel car achieves a 30 miles per gallon (mi/gal) fuel economy, the two cases show essentially the same cost, slightly less than 9 cents per mile, for the purchase and operation of the automobile. Other costs not included in Tables B-1 and B-2 add 3 or 4 cents per mile to the total. These are charges for taxes, registration, and insurance, taken to be the same for the synfuel and electric automobiles.

1. Life Cycle Costs of Alternatives

Table B-3 compares the two cases showing only the complete life cycle (10 years and 100,000 miles) costs of those items that can contribute to a significant difference between total costs of operating the synfuel and electric cars. The assumption that \$500 can be saved on the engine-drive train subsystem [i.e., \$400 for the electric versus \$900 for the internal combustion engine (ICE) with emission controls], represents an optimistic view of electric car costs. Still, the price of \$5200 for the electric car is characteristic of an intermediate or full-sized car, not the subcompact, in today's market. The 30 mi/gal fuel economy for the ICE is optimistic for a uniform charge Otto cycle engine meeting the statutory emission standards. At 25 mi/gal the fuel

* Excerpted from: E. E. Hughes, et al., "Long Term Alternatives for Automotive Propulsion--Synthetic Fuel Versus Battery Electric System," Stanford Research Institute (August 1976).

Table B-1

OPERATING COSTS FOR SYNTHETIC FUELED SUBCOMPACT CAR

	Years 1-3 (39,000 miles)	Years 4-10 (61,000 miles)	Total 100,000 miles
Depreciation	\$1,250	\$2,050	\$3,300
Repairs and maintenance	420	1,900	2,320
Tires	50	280	330
Accessories	10	50	60
Gasoline*	975	1,525	2,500
Oil	<u>50</u>	<u>110</u>	<u>160</u>
Total costs	\$2,750	\$5,950	\$8,700
Cost per mile	0.071	0.097	0.087

* Assuming 30 mi/gal and \$0.75/gal. At 25 mi/gal the figures would be:

Gasoline	1,170	1,830	3,000
Total	2,965	6,255	9,200
Cost per mile	0.075	0.101	0.092

Note: Totals may not add because of rounding.

Sources: 1975 Pinto Blue Book Price: \$3,300, 2500 lb.
Federal Highway Administration, "Cost of Operating an Automobile" (April 1974).

1974 prices adjusted by appropriate price indices.

Table B-2

OPERATING COSTS FOR ELECTRIC CAR WITH ADVANCED BATTERY*

	<u>Years 1-3</u> <u>(39,000 miles)</u>	<u>Years 4-10</u> <u>(61,000 miles)</u>	<u>Total</u> <u>100,000 miles</u>
Depreciation			
Vehicle	\$1,090	\$1,710	\$2,800
Battery	900	1,500	2,400
Repairs and maintenance	250	750	1,000
Tires	70	350	420
Accessories and oil	15	60	75
Electricity	<u>700</u>	<u>1,100</u>	<u>1,800</u>
Total costs	\$3,025	\$5,470	\$8,500
Cost per mile	0.078	0.090	0.085

* Assumptions:

Vehicle - 1975 Pinto less \$200 for pollution control devices, and \$300 savings on rest of engine and power train.

Battery - 40 kWh capacity costing \$60/kWh and having a lifetime of 1000 cycles or 10 years. Weighs 570 lbs.
No salvage value is assumed.

Repairs and maintenance - Estimate compiled from several sources.

Tires - Costs for seven new regular tires and four snow tires over 10 years.

Accessories and oil - Estimate based on Federal Highway Administration data.

Electricity - Total usage 0.45 kWh/mi at cost of \$0.04/kWh (1.8¢/mile).

Note: Totals may not add because of rounding.

Table B-3

COMPARISON OF AUTOMOBILE TRANSPORTATION COSTS

Cost Element	Total Cost (Over 10 Years and 100,000 miles)	
	Synfuel	Electric
Automobile		
Battery	\$ 0	\$2400
Engine and drive train	900	400
Vehicle body	<u>2400</u>	<u>2400</u>
Total Automobile	\$3300	\$5200
Financing charges*	880	1390
Fuel or electricity	2500 [†]	1800 [‡]
Repairs and maintenance	<u>2300</u>	<u>1000</u>
Total [§]	\$8980	\$9390

* Approximate costs for 5-year loan on 80 percent of total automobile cost at 12 percent interest rate.

[†] Assuming 30 mi/gal and \$0.75/gal.

[‡] Assuming 0.45 kWh/mi and \$0.04/kWh.

[§] Other costs are approximately 4¢/mi for each vehicle.

cost would be \$3000 over the 10 years, and the bottom line would read \$9400 instead of \$8900. The electric car has been credited with substantial (factor of 2) savings over the synfuel ICE on maintenance and repair costs. Uncertainties in any of the four basic cost terms listed--automobile, financing, energy, and repairs and maintenance--are large enough to cause one or the other alternative to have a slight advantage at the bottom line of Table B-3. The most significant uncertainty is

the initial cost of the electric automobile.

2. Analysis of Cost Inputs

The sensitivity of the cost picture of Table B-3 to the results of energy R&D programs can be illuminated by specifying the terms that have contributed to the battery and energy costs in the table. The \$2400 battery cost is based on a 40-kWh lithium-sulfur battery sold to the consumer at \$60/kWh after being manufactured at a cost of about \$30/kWh. The battery lifetime of 1000 deep discharge cycles is sufficient to last the full 10 years at 10,000 miles per year. A five-year lifetime for a battery costing the same amount to manufacture would mean a doubling of the amortization and financing costs of the battery to \$5950 (\$4800 for amortization plus \$1150 for financing), thereby contributing 6¢/mi rather than 3¢ per mi to the total operating costs of about 13¢/mi (allowing 4¢/mi for costs not included in Table B-3). The costs in Table B-3 are based on a battery characterized as \$6/kWh-year and result in a 3¢/mi transportation cost. Other cost-life combinations can be scaled accordingly.

The coal liquefaction plant is the major contributor to the \$0.75/gal gasoline cost used in Table B-3. To compare the contributors to this gasoline price with the contributors to the energy price of the electric alternative, the dollar flow, or value-added, along both energy supply routes is shown in Table B-4. The coal price used in the table (\$10/ton) includes delivery and could be set at other values, ranging from as low as \$5/ton to as high as \$20/ton. At a price of \$15/ton the coal and nuclear generating costs would both be about 2¢/kWh.

From the cost figures presented in Table B-4 it is apparent that the energy advantage of the electric alternative, which is demonstrated in Part B of this Appendix, does not translate into an economic advantage because the cost of coal contributes less than one-fifth of the cost of the energy delivered to the automobile. When the influence of the cost of coal is further diluted by considering the other factors contributing to total transportation costs, it becomes apparent that extremely large increases in the cost of coal would be required to

Table B-4

CONTRIBUTORS TO SYNFUEL AND ELECTRIC ENERGY COSTS

Part I

DOLLAR FLOW FOR SYNTHETIC FUEL SYSTEM

<u>System Component</u>	<u>Cumulative Value Added</u>		<u>Value Added in Dollars per 10⁶ Btu of Delivered Energy</u>
	<u>Price in Units Characteristic of Component</u>	<u>Dollars per 10⁶ Btu</u>	
Coal (mine plus transport)	\$10/ton	\$0.63	\$0.89
Liquefaction plant	\$18/barrel	3.10	2.54
Refinery	\$0.60/gal	4.75	1.33
Transportation and distribution system	\$0.75/gal	5.95	<u>1.19</u>
Total (price used in Table B-3)	\$0.75/gal		\$5.95

Part II

DOLLAR FLOW FOR ELECTRIC ENERGY SYSTEM

<u>System Component</u>	<u>Cumulative Value Added</u>		<u>Value Added in Dollars per 10⁶ Btu of Delivered Energy</u>
	<u>Price in Units Characteristic of Component</u>	<u>Dollars per 10⁶ Btu</u>	
Fuel			
Coal (mine plus transport)	\$10/ton	\$0.63	\$1.98
Uranium (entire cycle)	\$65/lb (3.5 mills/kWh)	0.32	1.17
Power generation			
Coal-fired plant	16 mills/kWh	4.70	3.33
Nuclear plant	19 mills/kWh	5.55	5.10
Transmission and distribution	4¢/kWh	11.70	<u>5.43</u>
Total (price used in Table B-3)	4¢/kWh		\$11.70 (nuclear) \$10.70 (coal)

change the energy advantage of the electric alternative into a significant economic advantage.

B. Energy Efficiency

To compare the energy resource utilization efficiency of the synfuel and electric alternatives, we have attempted to place the systems supporting these two transportation modes on common ground. In the systems chosen for analysis, the primary resource is subbituminous coal surface mined in the Powder River Basin of Wyoming. The coal is assumed to be converted to electricity or synthetic crude oil near the minemouth. The electricity or syncrude is then transported 1000 miles (corresponding roughly to Chicago or St. Louis) by high voltage power line or pipeline. The electricity is distributed to homes or businesses, where it is used to charge vehicles utilizing lithium-sulfur batteries. The syncrude is refined to gasoline and other products, and the gasoline is distributed to filling stations for use in conventional automobiles. In both cases, the end use is assumed to be 1 million vehicles operating for one year over an average distance of 10,000 miles, a total of 10 billion VMT.

The gasoline required for propulsion of the conventional vehicles could be provided by refining the syncrude from a coal liquefaction plant of about 50,000-B/D capacity, assuming a typical refinery gasoline output of 50%. In the case of electric vehicles, the required electricity could be produced by a 750 MW power plant operating at 70% of capacity.

1. Method of Calculating Energy Resource Consumption

The calculation of the energy resource consumption efficiency of automobile transportation proceeds in a manner similar to that used in the calculation of the net energy yields of synthetic liquid fuel technologies in Reference 1. In that study, the appropriate figure of merit was the "net energy ratio," which is defined as the ratio of the energy content of the product of an energy conversion process to the sum of the energy inputs for constructing, operating, and maintaining the conversion facilities, and including the energy lost during the conversion process. These energy inputs are expressed in the form of resource energy, that is,

the energy content of the resources in the ground required to supply the fuels or electricity consumed in construction, operation, and so forth.

In the case of the two automotive energy alternatives, the appropriate figure of merit will be Btu per vehicle-mile of transportation (Btu/VMT). To account for all the resource energy required to deliver transportation, the energy content of the primary coal resource will be summed with the energy content of additional coal, crude oil, wellhead natural gas, and nuclear and hydropower equivalents required to construct and operate the conversion plants, refineries, transmission lines, automobiles, and so forth, that make up the coal-to-transportation systems.

2. Comparison of Alternatives

The total energy requirements for the synfuel system and the electric system, respectively, are shown in Figures B-1 and B-2. The numbers beneath each box (representing system components) show the direct flow of energy through the system in 10^{12} Btu/yr. The numbers in the triangles show the additional resource energy requirements for construction, maintenance, and operation of the system components. The total energy consumption per VMT is calculated by adding the energy content of the original coal resource (E_{coal}) that was processed through the system to provide motive power to the sum of all the additional energy inputs (E_i) and dividing by the total vehicle-miles traveled. As shown in the two figures, the total resource energy requirement for the electric vehicle, 7360 Btu/mi, is about 23% less than the synfuel vehicle requirement, 9540 Btu/mi. These values are based on propulsion energy requirements of 0.033 gal/mi (30 mi/gal) and 0.45 kWh/mi for the synfuel-powered and battery-powered vehicles, respectively.

To obtain the results in Figures B-1 and B-2, other components of the coal-to-vehicle transportation system were analyzed in a manner similar to that used in Reference 1 for coal liquefaction. Published information on the efficiency, costs, or materials requirements were used for calculations of the energy inputs and outputs of the pipeline², refinery³, and distribution³ components of the synfuel system, and the electric generation⁴, transmission⁴, and distribution⁵ components of the

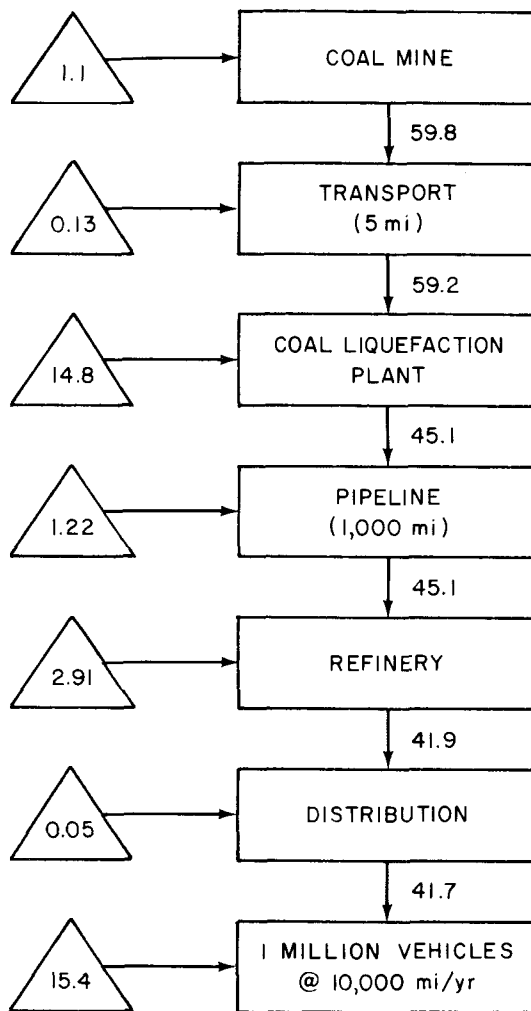

$$\text{OVERALL VEHICLE ENERGY EFFICIENCY} = \frac{E_{\text{coal}} + \sum E_j}{10^{10} \text{ vehicle-mi}} = \frac{(59.8 + 35.6) \times 10^{12}}{10^{10}} = 9540 \text{ Btu/mi}$$

Note: All energy values are in 10^{12} Btu/yr
 E_j refers to energy inputs in triangles.

Rectangles represent system components. Triangles represent energy requirements for construction, operation, and maintenance of components. Vertical arrows represent flows of energy through the system, while horizontal arrows represent external energy inputs.

FIGURE B-1. ENERGY CONSUMPTION OF COAL-TO-SYNFUEL VEHICLE SYSTEM

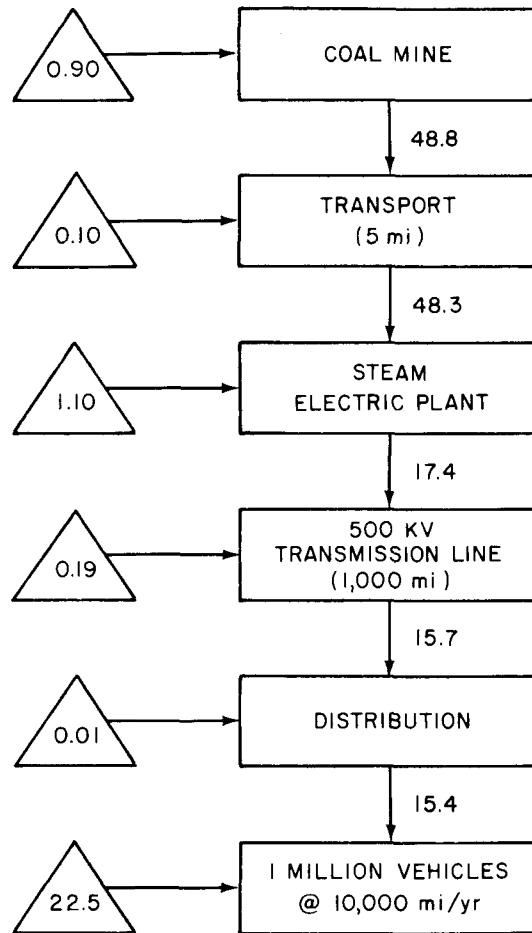

$$\text{OVERALL VEHICLE ENERGY EFFICIENCY} = \frac{E_{\text{coal}} + \sum E_i}{10^{10} \text{ vehicle-mi}} = \frac{(48.8 + 24.8) \times 10^{12}}{10^{10}} = 7360 \text{ Btu/mi}$$

Note: All energy values are in 10^{12} Btu/yr
 E_i refers to energy inputs in triangles.

Rectangles represent system components. Triangles represent energy requirements for construction, operation, and maintenance of components. Vertical arrows represent flows of energy through the system, while horizontal arrows represent external energy inputs.

FIGURE B-2. ENERGY CONSUMPTION OF COAL-TO-ELECTRIC VEHICLE SYSTEM

electric system. An important component of the energy use is that required for the production and maintenance of the automobile. The energy requirements for manufacture of conventional automobiles has been calculated by Berry and Fels.⁶ Their number has been used directly, except that the energy requirement for the vehicle considered in this report has been scaled by the ratio of the weight of the vehicle considered here (2000 lb) to the vehicle weight they used (3500 lb). Energy requirements for vehicle maintenance, oil, tires, and so forth were taken from Reference 7.

The calculation of the manufacturing energy requirements of the battery powered vehicle is more difficult. Basically, we have assumed that the conventional vehicle is modified by removing the engine and drive train and adding the 570-lb lithium-sulfur battery, electric motor, and controllers. The quantities of materials removed from the conventional vehicle and added for the electric vehicle (with the exception of the battery) were obtained from Reference 8. Energy requirements for these materials are readily calculated. The most difficult, and least certain calculation of energy requirements is for the lithium-sulfur battery. This is because the lithium-sulfur battery represents an area of advance technology that is currently only in the R&D stage. In Reference 9, however, the materials requirements and approximate expected costs (in late 1973 dollars) for a production model lithium-sulfur battery were estimated. Using these figures, an energy requirement of 80 million Btu was estimated for the manufacture of a 570-lb lithium-sulfur battery. This figure represents approximately one-half of the total energy estimated for production of the electric car (155 million Btu). The battery estimate is expected to have large error limits, on the order of $\pm 50\%$. The maintenance and tire replacement energy requirements were assumed to be the same as for the conventional vehicle. The engine oil requirement was omitted.

Figure B-3 shows the parametric variation of total resource energy requirements with propulsion energy requirements. This figure displays the sensitivity of total energy consumption to attainment of the vehicle design goals. The sensitivity of the electric vehicle total energy requirement to propulsion energy requirement is about 73% greater

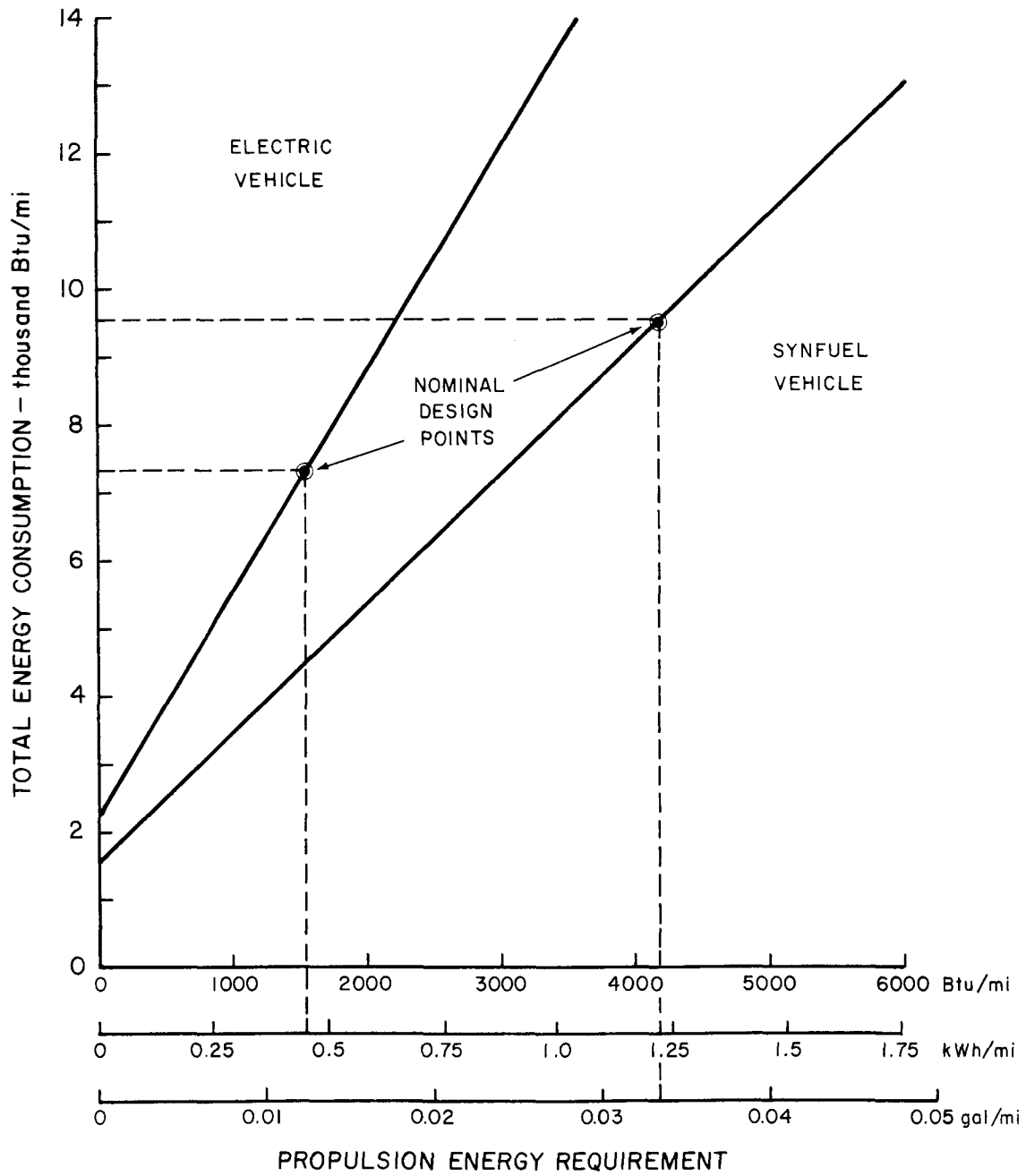

FIGURE B-3. TOTAL ENERGY COMPARISON OF ELECTRIC- AND SYNTHETIC FUEL-POWERED VEHICLES

than for the synfuel vehicle, primarily because of the inefficient coal-to-electricity conversion step.

Changes in design goals could have significant effects on the relative resource energy consumption of the two systems. For example, a conventional vehicle achieving an average 40 mi/gal fuel economy would consume about the same resource energy as an electric vehicle requiring 0.50 kWh/mi. These figures represent a substantial improvement over current conventional vehicle capabilities and a relatively small slippage in battery design goals.

The achievement of the 0.45 kWh/mi design goal for electric cars will mean a significant improvement in overall energy consumption compared with synthetic fuel-powered vehicles attaining an average fuel economy of 30 mi/gal. The battery-powered vehicle will consume 23% less resource energy per mile. If one considers only the direct coal input into electric power plants or liquefaction plants for the purpose of vehicle propulsion, the energy consumption is less by 18% for the electric vehicle.

REFERENCES FOR
APPENDIX B

1. E. M. Dickson et al., "Impacts of Synthetic Liquid Fuels Development: Assessment of Critical Factors," U.S. Energy Research and Development Administration, ERDA 76-129/2 (1976).
2. U.S. Department of the Army, Corps of Engineers, "Report on Gulf Coast Deep Water Port Facilities--Texas, Louisiana, Mississippi, Alabama and Florida (June 1973).
3. Hittman Associates, Inc., "Environmental Impacts, Efficiency and Costs of Energy Supply and End Use," Vol. 1, Report No. HIT-56 (November 1974).
4. Westinghouse Environmental Systems, "Colstrip Generation and Transmission Project: Applicant's Environmental Analysis" (November 1973).
5. Westinghouse Electric Corporation, "Electrical Transmission and Distribution Reference Book" (East Pittsburgh, Pennsylvania, 1950).
6. R. S. Berry and M. F. Fels, "The Production and Consumption of Automobiles," Report to the Illinois Institute of Environmental Quality (July 1972).
7. E. Hirst, "How Much Overall Energy Does the Automobile Require?," Automotive Engineering, 80 (July 1972).
8. W. F. Hamilton, Impact of Future Use of Electric Cars in the Los Angeles Region: Volume I--Executive Summary and Technical Report, Volume II--Task Reports on Electric Car Characteristics and Baseline Projections, Volume III--Task Reports on Impact and Usage Analyses, prepared for U.S. Environmental Protection Agency, Contract No. 68-01-2103, EPA-460/3-74-020-a,b,c, General Research Corporation, Santa Barbara, California (October 1974).

Appendix C

SENSITIVITIES OF DELIVERED AUTOMOTIVE ENERGY COSTS TO CHANGES IN THE COSTS OF SYSTEM COMPONENTS

Figures C-1 to C-6 show the sensitivity of the total energy cost to the changes in the value used for various cost components. These displays also indicate the degree to which the total cost is sensitive to the changes in component costs. Using the information presented in these displays, we can determine the impact of uncertainty in the cost estimate for each component on the total cost. Additionally, the displays reveal when improved information will produce greater payoffs. For example, Figure C-1 indicates that the total cost of supplying gasoline derived from syncrude is most sensitive to the estimates of coal conversion cost, followed by cost for product distribution, refining, coal extraction, coal transportation, product transportation, and crude transportation. Therefore, additional resources expended to improve the cost estimates for coal conversion and product distribution will be more worthwhile than attempting to improve the information on the costs to transport crude petroleum.

Comments about the sensitivity of the total cost of supplying automobile fuel from each option with reference to each figure follow. These comments, as well as the figures, correspond to the maximum cost pathway for each option.

Syncrude--Figure C-1

The total cost is most sensitive to the estimate of cost for coal conversion. In fact, the sensitivity to the coal conversion cost is more than twice that of all other components put together. The total cost is not so sensitive to coal transportation as it is generally thought to be.

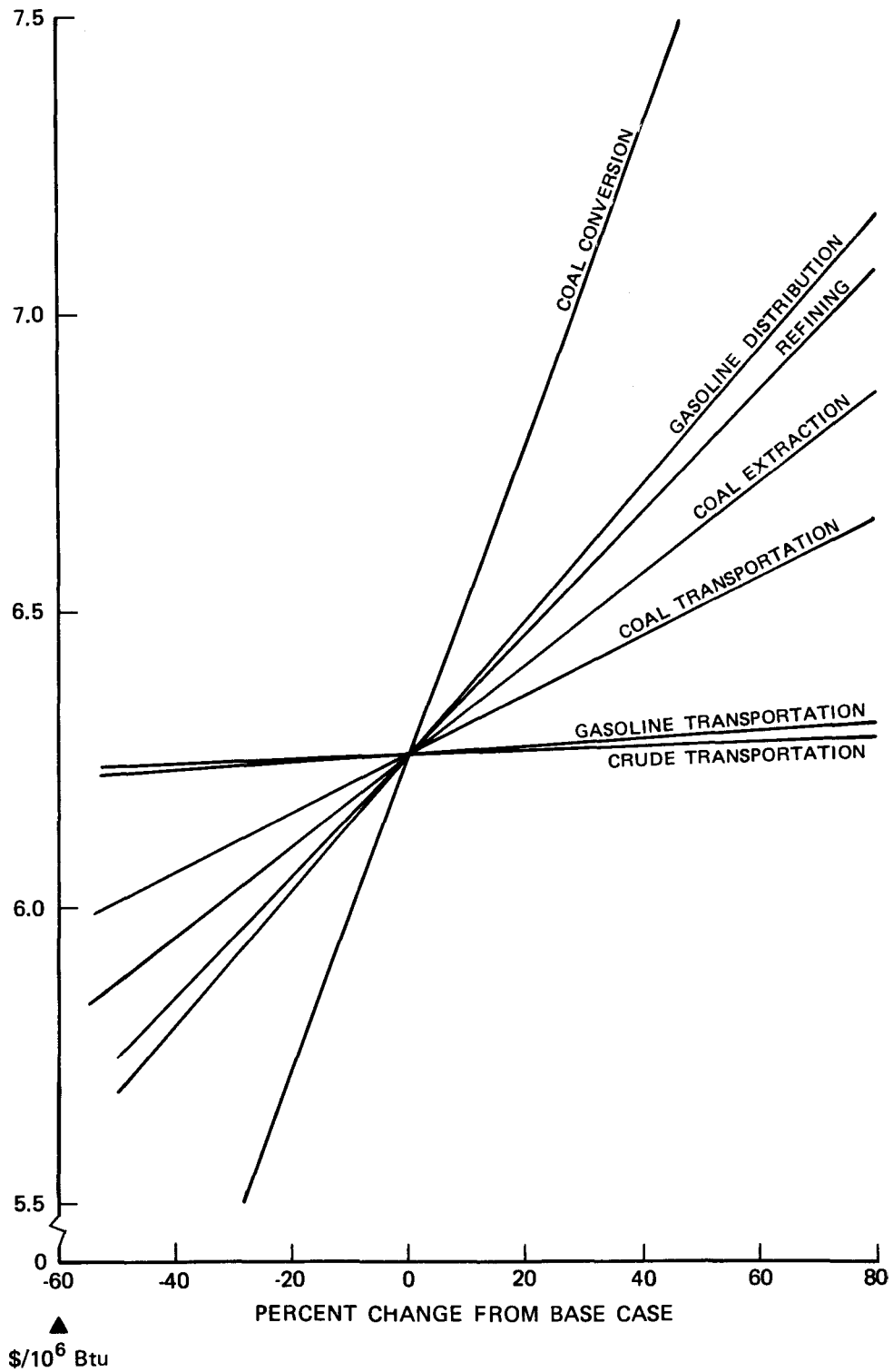

FIGURE C-1. COST SENSITIVITY: SYNCRUDE PLANT IN BEAUMONT, TEXAS USING APPALACHIAN UNDERGROUND COAL

Methane--Figure C-2

The total cost is most sensitive to the changes in the cost of coal conversion, followed by product distribution, methane liquefaction, coal extraction, coal transportation, and product transportation. However, differences in the sensitivity to the changes in coal conversion cost and other component costs are not so great as for syncrude.

Much can be gained by improving the estimate for coal conversion, methane liquefaction, and liquefied methane distribution.

Methanol--Figure C-3

The total cost is most sensitive to the variation in coal conversion cost, followed by costs of product distribution, coal extraction and transportation, and product transportation. In fact, the sensitivity to change in coal conversion cost is more than twice that of all other components combined.

Fischer-Tropsch Gasoline--Figure C-4

The total cost is most sensitive to cost of coal conversion, followed by product distribution, coal transportation, coal extraction, and product transportation. Again, the sensitivity to changes in coal conversion cost predominate, but the differences in sensitivity among changes in coal extraction, coal transportation, and product distribution are not significant.

Hydrogen--Figure C-5

The total cost is almost equally sensitive to the changes in costs for liquefaction, liquefied product distribution, and coal conversion. The total cost is practically insensitive to changes in cost for coal transportation and extraction.

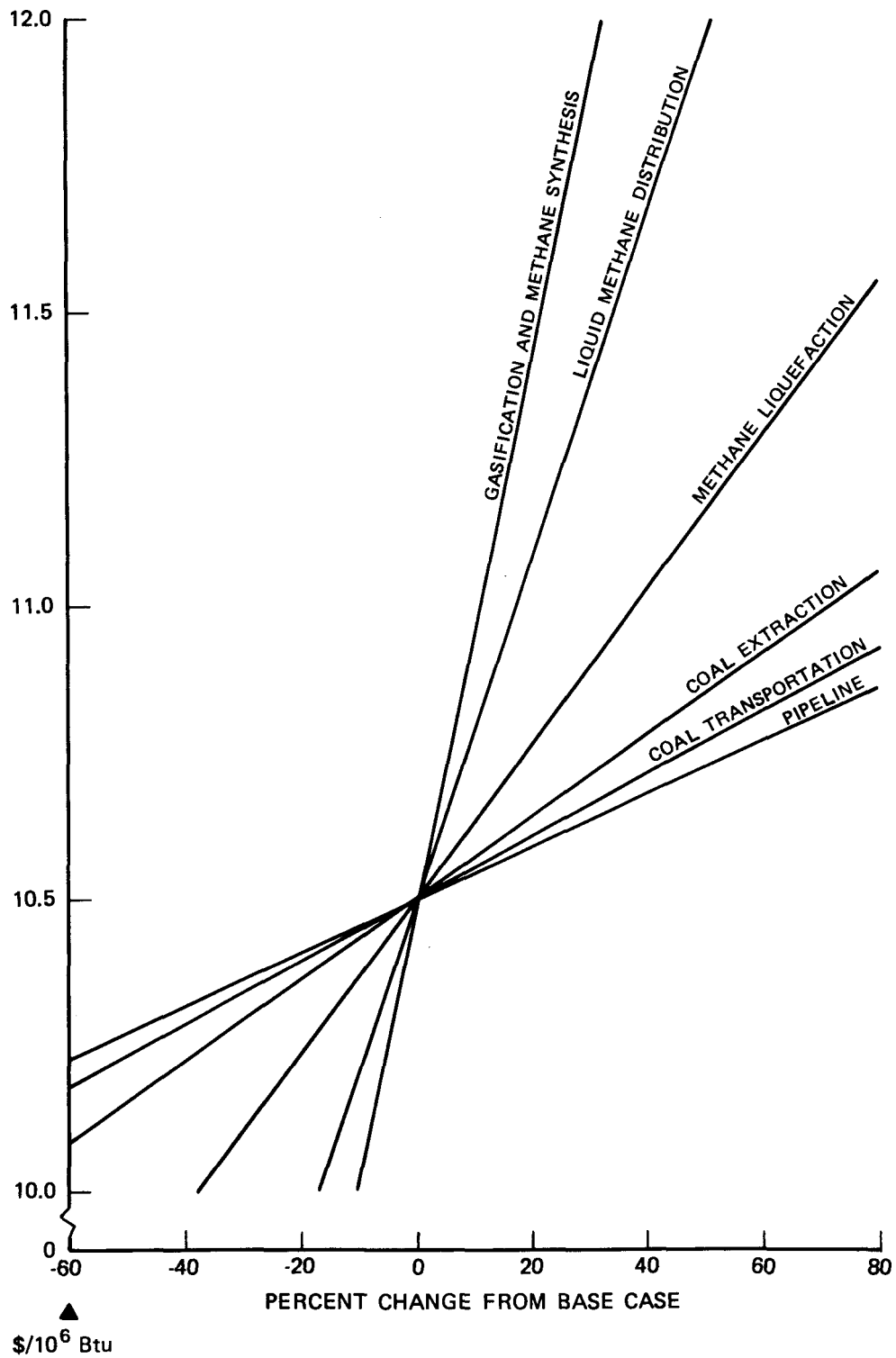

FIGURE C-2. COST SENSITIVITY: METHANE PLANT IN NEW ORLEANS, LOUISIANA USING ILLINOIS SURFACE COAL

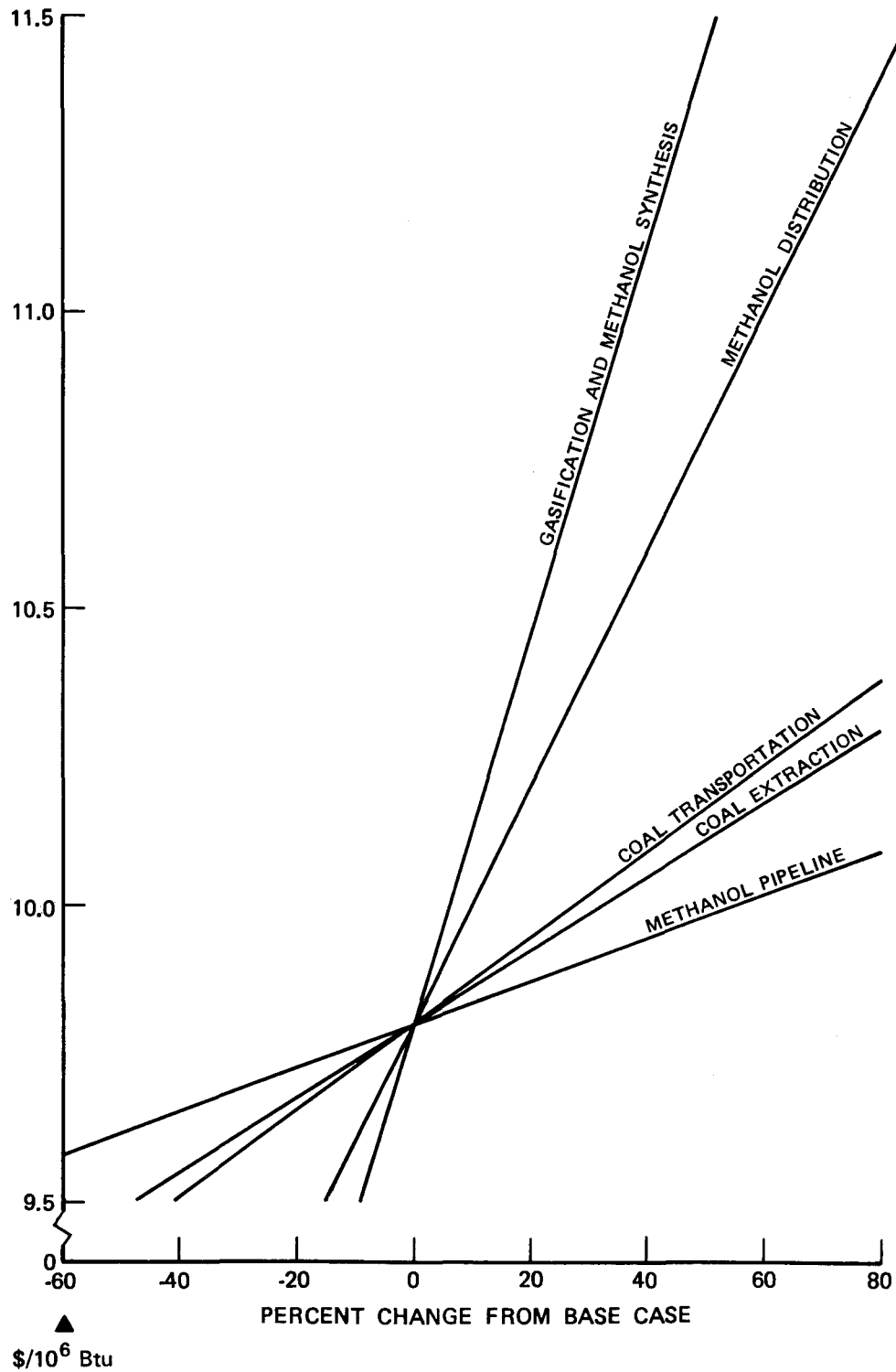

FIGURE C-3. COST SENSITIVITY: METHANOL PLANT IN GALVESTON, TEXAS USING APPALACHIAN SURFACE COAL

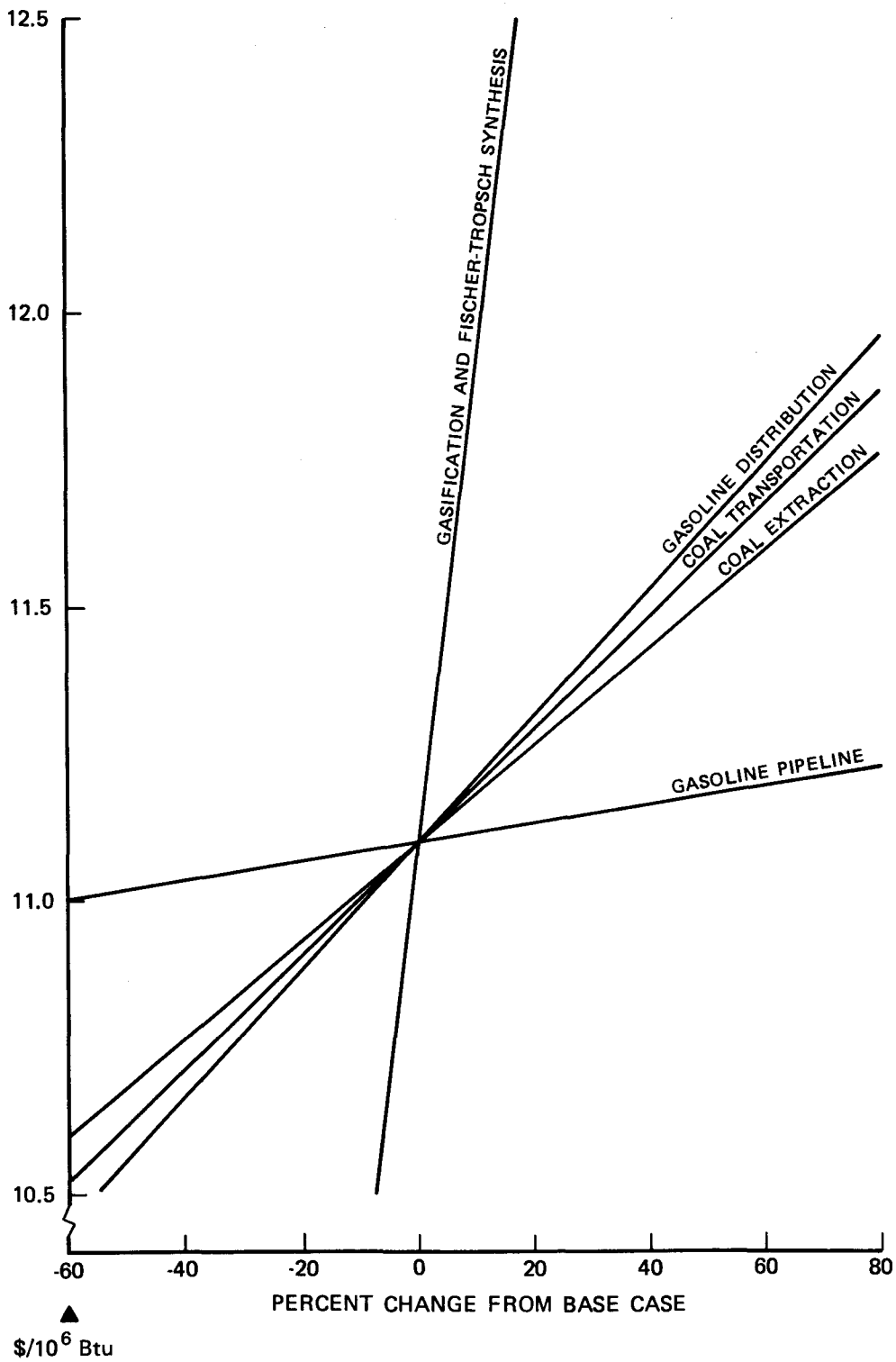

FIGURE C-4. COST SENSITIVITY: FISCHER-TROPSCH GASOLINE PLANT IN GALVESTON, TEXAS USING APPALACHIAN SURFACE COAL

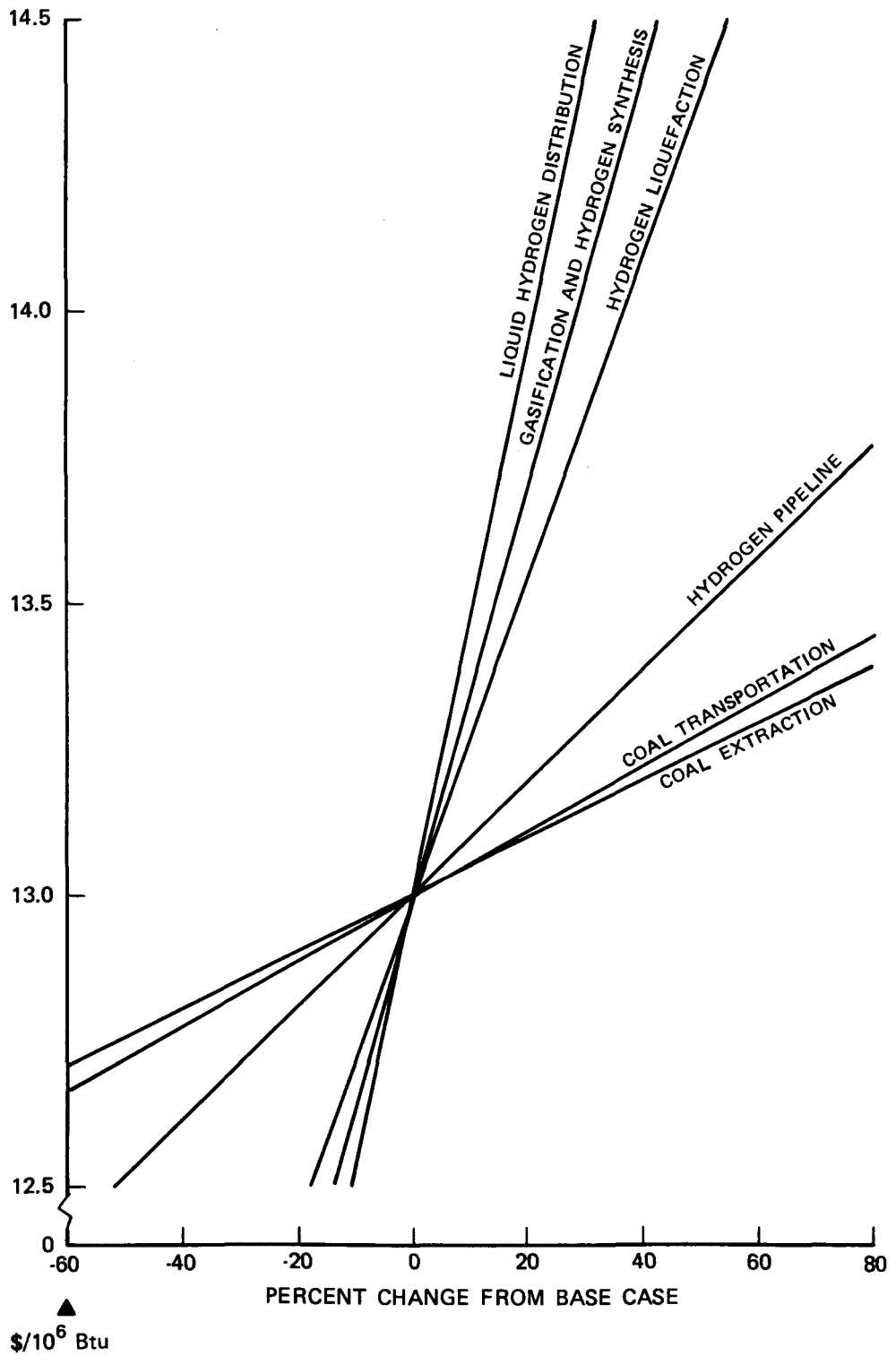

FIGURE C-5. COST SENSITIVITY: HYDROGEN PLANT IN GALVESTON, TEXAS USING APPALACHIAN SURFACE COAL

Electricity--Figure C-6

The total cost is most sensitive to changes in costs of transmission and distribution, followed by generation cost, and coal transportation and coal extraction costs.

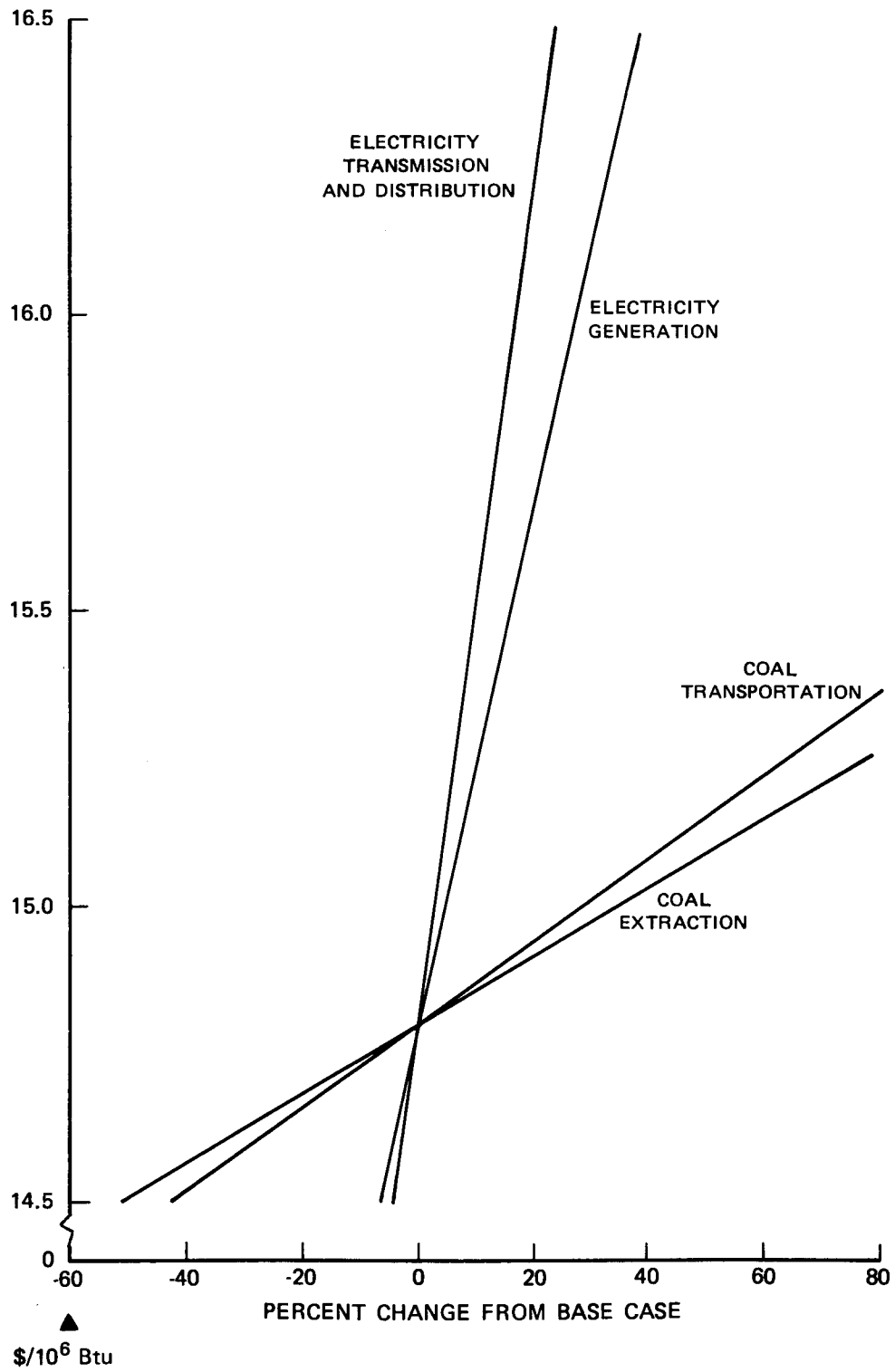

FIGURE C-6. COST SENSITIVITY: COAL FIRED POWER PLANT IN BOSTON, MASSACHUSETTS USING APPALACHIAN SURFACE COAL

Appendix D

CALCULATIONS OF ENERGY REQUIREMENTS FOR COMPONENTS OF AUTOMOTIVE ENERGY SUPPLY SYSTEMS

Coal Mining

In Chapter 5 of Volume II of this series, it was determined that for a western surface mine of moderate stripping ratio, the primary energy resource input requirement is about 1.6×10^{12} Btu for a 5×10^6 ton/yr coal mine.¹ Therefore, the energy input per 10^6 Btu of coal recovered is 3.2×10^5 Btu/HV, where HV is the heating value of the coal in 10^6 Btu/ton. Development Sciences, Inc., has calculated an energy input requirement of 1.6×10^{12} Btu for a 6.7×10^6 ton/yr surface mine,² or 2.4×10^5 Btu/HV per 10^6 Btu of coal. Although there are wide differences among various surface mines, including stripping ratios, ease of reclamation, and the like, we use an average figure of 2.8×10^5 Btu/HV per 10^6 Btu of coal mined.

For underground mining, Development Sciences, Inc., has calculated a figure of 1.7×10^{12} Btu energy input for a 5×10^6 ton/yr underground mine employing conventional room and pillar mining to recover coal from a 6-ft seam.² This figure translates to 3.4×10^5 Btu/HV per 10^6 Btu of coal mined.

Coal Transport

The four coal transportation modes considered are truck, unit train, slurry pipeline, and barge. The last three modes would be employed in long-distance coal transport, whereas trucks would only be used when the conversion facility is within a few miles of the mine.

Fuel consumption for trucks varies widely, depending on the size of the truck, distance traveled, road conditions, and similar considerations. For large trucks, we have assumed a generally accepted total energy input

of 2000 Btu/ton-mi. Thus, the energy consumed in a hauling application is $(2000 \times L/HV)$ Btu per 10^6 Btu hauled, where L is the haul distance in miles.

For unit trains, many conflicting data exist. However, three analyses which were carefully carried out yielded figures of 430, 340, and 290 Btu/ton-mi of diesel fuel consumption for long-distance unit trains.^{2,3,4} Because we have no firm basis for choosing one over the other, we use an average of 385 Btu/ton-mi. Converting this figure to primary resource consumption and adding 30 Btu/ton-mi for train construction and maintenance, as well as track maintenance, the total is 490 Btu/ton-mi.²

The energy inputs for a coal slurry pipeline are based on an analysis of the proposed 1000-mi Wyoming-Arkansas pipeline, which would have a capacity of 25×10^6 ton/yr. The electric pumps and coal slurring equipment would consume 0.054 kWh/ton-mi.^{3,5} Converting this to primary resource consumption gives 680 Btu/ton-mi. The construction and maintenance of the pipeline add another 75 Btu/ton-mi, for a total of 760 Btu/ton-mi.

Energy inputs for coal barges are based on a diesel fuel consumption of 220 Btu/ton-mi.⁶ Converting to primary resource energy and adding barge construction and maintenance result in a total of about 300 Btu/ton-mi.

Coal Conversion

For our analyses, the energy consumption by coal conversion technologies may be expressed by two quantities: the efficiency of the process, and the direct and indirect ancillary energy required to construct and operate the conversion facility. The process energy efficiency is not simply the thermal efficiency of the coal-to-product conversion. Rather, it is a total energy efficiency, defined as the heat content of the product divided by the heat content of all the coal used in the facility, including that burned to provide steam and heat. This definition is arbitrary because the coal used as plant fuel could be just as easily included in the ancillary energy requirement. However, this definition is consistent with our cost analysis, which uses total energy

efficiency to determine the contribution of coal cost to the total conversion cost. When the engineering analysis of a particular technology assumes the purchase of electricity for plant operation, the coal required to produce this electricity has been assigned to the energy input requirements, based on a coal-to-electricity thermal efficiency of 35%.

Coal liquefaction using the H-coal process and coal-to-methanol conversion using Lurgi gasification have been analyzed in Volume II. For coal liquefaction, the overall coal-to-syncrude efficiency is 0.63 for western subbituminous coal, and 0.68 for eastern bituminous coal. In both cases, the indirect ancillary energy requirement is 2.7×10^4 Btu per 10^6 Btu of product.

For methanol production using subbituminous coal, the overall energy efficiency is 0.41, including by-product naphtha in the output. The indirect ancillary energy requirement is 3.5×10^4 Btu per 10^6 Btu of product. An engineering analysis of methanol production from Illinois bituminous coal using a Koppers-Totzek gasifier has been carried out.⁷ Based on this analysis, the overall energy efficiency is calculated to be 0.40, and the indirect ancillary energy requirement is 4.5×10^4 Btu per 10^6 Btu of product.

We have derived energy requirements for converting coal to SNG from data published on the planned construction of two SNG plants in New Mexico.^{8,9} The plant designs are based on the use of Lurgi gasification technology. The resulting energy conversion efficiency is about 0.56. A published engineering cost analysis has been used to derive an indirect energy requirement of 2.7×10^4 Btu per 10^6 Btu of SNG produced.¹⁰ There are no equivalent analyses for the gasification of eastern bituminous coal. However, estimates of energy efficiency for more advanced gasifiers are suitable for eastern coal. These efficiencies range from around 55 to 62%.¹¹ However, in the absence of more substantial data, the energy requirements for eastern bituminous coal gasification are assumed to be the same as those for western subbituminous.

The use of advanced gasification technology on different processing schemes, such as the regasification of byproduct tars and oils, could

increase the overall efficiency from both eastern and western coal. However, the figure presented here will be retained since it is consistent with the cost estimates discussed in Chapter 3.

The production of hydrogen from coal is a simpler operation than the production of SNG. Because the products of coal gasification are primarily CO and H₂, the only major remaining steps are the further reaction of CO with the steam to produce H₂ and CO₂, followed by the removal of CO₂ and other impurities. The overall efficiency for coal-to-hydrogen conversion is 0.59,¹² assuming the use of low-pressure, high-temperature gasifiers that minimize methane production. The other indirect energy requirements amount to 3.7×10^4 Btu per 10^6 Btu of hydrogen produced.¹³

Coal gasification, followed by Fischer-Tropsch synthesis to produce gasoline and chemical by-products, is inefficient. Under optimum conditions, the processing of gasifier by-products--tar, tar oil, and naphtha--produce additional gasoline; the overall efficiency for producing motor fuels, including a small amount of diesel fuel, is about 0.30.¹⁰ Due to the high capital and operating costs for this process, the indirect energy requirement is correspondingly high in relation to other conversion technologies-- 4.9×10^4 Btu per 10^6 Btu of motor fuel.

Using coal-fired boilers and steam turbines to generate electricity is a well-established technology for which it is relatively easy to estimate energy consumption figures. The thermal efficiency for such plants can approach 40%. However, due to the power requirements for ancillary equipment such as stack gas scrubbers, the net efficiency can be as much as 10% lower. We have used a conservative estimate of 0.35 net efficiency for a modern base load steam electric plant. This figure applies to both low-sulfur, low-heating value western coal and to high-sulfur, high-heating value eastern coal.¹⁴ The larger coal-handling requirements in the former case tend to balance out the stack gas scrubbing requirements in the latter case as they affect net efficiency. The indirect energy requirement per 10^6 Btu of electricity generated is 6.3×10^4 Btu.¹⁴

In-Situ Gasification

The gasification of coal in place by injection of steam and oxygen is known as in-situ gasification. This process has the potential for substantially reducing both the costs and environmental impacts of producing clean fuels from coal. The expenses and impacts of coal mining are eliminated, as is the requirement for highly capital-intensive above-ground gasification equipment. After synthesis gas has been produced, however, it must be brought to the surface for purification and subsequent production of methane, methanol, or other products with conventional equipment.

The Lawrence Livermore Laboratory (LLL) has performed conceptual engineering and cost analyses of producing methane^{15,16} and methanol¹⁷ by in-situ gasification of deep, thick western coal seams. They consider this method a promising alternative to the mining of these seams, for which there is as yet no suitable technology. Because little development has been carried out on the LLL in-situ method, the quantitative aspects of the technology must be considered speculative.

In the LLL analysis of producing SNG (or methane) by in-situ gasification, the overall coal-to-methane efficiency of the process is 0.76. This figure excludes the mined coal required to produce steam and power. Because of the different nature of this coal source, its energy value is added to the indirect ancillary energy requirement of 4.1×10^4 Btu for a total ancillary energy requirement of 2.3×10^5 Btu per 10^6 Btu of methane product.*

*The additional coal requirement specified in Reference 15 was derived from a coal requirement for steam and power for an aboveground Lurgi gasification plant that was one-third too low. Therefore, the coal requirement was increased by 50% for this analysis. The methanol coal requirement in Reference 17 was also too low and was ratioed to the methane coal requirements by the ratio of ancillary coal requirements for aboveground conversion plants.

For methanol, the overall efficiency of converting in-situ coal to the final product is 0.65. The ancillary energy requirement, including additional coal to produce steam and power, is 4.6×10^5 Btu per 10^6 Btu of methanol.

The efficiencies quoted above are based on the coal actually affected by gasification. They do not include the coal that must be left in place to form barriers between the underground gasification chambers. The inability to recover this coal is analogous to conventional underground mining in which some coal is left in place to support the mine roof.

Product Transportation

All liquid and gaseous fuels discussed in this section can be transported via pipeline. Indeed, pipelines are currently the most common form of shipment for crude oil, petroleum products, and natural gas. Methanol, which has about the same density as gasoline, could easily be shipped through existing pipelines. Hydrogen could be shipped through natural gas pipelines, although some modifications would be required, and the operating conditions would be different.

The calculation of energy requirements for crude oil pipelines is based on national statistics that indicate that the average pipeline diameter is about 18 in.¹⁸ The average motive power requirement is 154 hp/mi for this size pipeline.¹⁹ Nationally, about 76% of pipeline pumping requirements are met by electric motors, 16% by diesel-powered motors, and 8% by gas-driven motors.¹⁸ Assuming an electric motor power efficiency of 80%, and an energy consumption for gas- and diesel-powered engines of 9250 Btu/hp-hr,² the total resource energy requirement is 1720 Btu/ton-mi, or $48 \text{ Btu}/10^6 \text{ Btu-mi}$. The latter figure includes $1.2 \text{ Btu}/10^6 \text{ Btu-mi}$ for pipeline construction and maintenance.² Crude oil is assumed to have a density of 7.5 lb/gal, which corresponds to a light (bottoms-free) syncrude oil.

The pipeline transport of refined products such as gasoline requires about 60 hp/mi, for an 18-in. pipeline.¹⁹ If the total resource energy requirement is calculated like that for crude pipelines results, a figure of 540 Btu/ton-mi, or 15 Btu/10⁶ Btu-mi for gasoline, including pipeline construction and maintenance, results. For a methanol pipeline, it is assumed that the energy requirements per ton-mile are the same as for gasoline. However, because methanol has approximately half the energy content as a comparable unit weight of gasoline, the resulting energy consumption is approximately 30 Btu/10⁶ Btu-mi.

For natural gas pipelines, compressors use some of the gas as fuel. Thus, transportation energy consumption can be expressed as a transmission efficiency dependent on the pipeline length. For typical gas pipelines with diameters of 30 to 36 in. the transmission energy requirement is about 36 Btu/10⁶ Btu-mi, assuming a compressor efficiency of 9250 Btu/hp-hr.² Thus, the gas pipeline transmission efficiency may be expressed as $1.0 - 3.6 \times 10^{-5}$ L. The ancillary energy requirement for gas pipelines (construction plus maintenance) is about 4 Btu/10⁶ Btu-mi.²

For a hydrogen pipeline operating at the same pressure as a natural gas pipeline but otherwise optimized to carry hydrogen, a 25% increase in diameter and a 43% increase in compressor power are required to deliver the same amount of energy.²⁰ The resulting fuel requirement is 52 Btu/10⁶ Btu-mi. Assuming that hydrogen is used as the compressor fuel, the effective pipeline efficiency is $1.0 - 5.2 \times 10^{-5}$ L. The construction and maintenance energy requirement is about 5 Btu/10⁶ Btu-mi.

The transmission and distribution of electricity have an average efficiency of 0.91, based on national statistics.²¹ Because regional data were not available, this figure was used in all calculations. The construction and maintenance requirements for a high-voltage transmission line loaded at 1000 MW is approximately 12 Btu/10⁶ Btu-mi.¹⁴ The average transmission distance is assumed to be 500 mi.

Refineries

To calculate refinery energy consumption, we can use either data from the analysis of individual refineries or nationwide refinery statistics. Considerable variation from one refinery to the next occurs, and modifications in refinery operations required for refining syncrude would vary considerably depending on the type of crude the refinery accepts, the usual product slate of the refinery, and so forth. Therefore, to average such variations, we use nationwide refinery statistics available in the U.S. Bureau of Mines Mineral Industry Survey's Annual [1973] Petroleum Statement.²² In addition, the indirect energy requirements for refinery construction and operation have been calculated by Development Sciences, Inc.²

In 1973, 4.58 billion barrels of crude petroleum (including a small amount of imported unfinished oils) were refined in the U.S. The refining of this petroleum, plus the blending of 308 million barrels of natural gas liquids and other hydrocarbons such as tetraethyl lead, produced 5.06 billion barrels of refined products. The typical, slight volume expansion that occurred was due to processes such as hydrotreating in which heavy oils were converted to lower density products.

Of the 5.06 billion barrels produced, 488 million barrels consisting mainly of fuel oil and refinery gases, were consumed as fuel in refinery operations. In addition, 1.11 trillion cubic feet of natural gas, 41 million barrels of liquefied petroleum gases (LPG), 7.9 million tons of coal, 80 billion kWh of electricity, and 41 billion lb of steam were purchased for refinery operations. Assigning the heating values to crude oil and products specified in the Bureau of Mines Annual Petroleum Statement and adding the indirect energy requirements calculated by Development Sciences, Inc., we arrive at the following figures: On the basis of crude oil refined to products (blending of natural gas liquids is not included), the energy efficiency of refining is 0.96, and the external requirement is 6.2×10^4 Btu per 10^6 Btu of products. This latter figure is based on net yield of products, and does not include those products consumed as refinery fuel in the denominator. (See Appendix A for a more detailed accounting.)

Approximately half of the product yield from crude refining is gasoline or diesel fuel used in automotive transportation. For the calculations in this Appendix, we assume that the energy consumed in refining is attributable to all products equally and is apportioned according to their relative energy contents. Although, this is undoubtedly not the case in actual refining operations, the calculation of energy consumption based on each type of product produced would be an extremely complicated task, and the results would be sensitive to individual refinery and crude oil parameters. Thus, the figures derived from aggregate refinery statistics appear to be the most reasonable for our purposes.

Methane and Hydrogen Liquefaction

To use methane or hydrogen as automotive fuels requires storage of these chemicals within the vehicle in a way which minimizes weight and volume requirements. The storage of gases in high-pressure cylinders--the method employed in many industrial applications--is generally unsuitable for automotive applications because of the excessive weight and volume of the cylinders. The major alternative is the storage of methane or hydrogen as a liquid in a cryogenic vessel, although metal hydride storage of hydrogen has also been considered. When stored as a liquid, methane has a somewhat higher energy content per unit weight than gasoline, and hydrogen has 3 times the energy content. However, the volumetric requirements for storage of these fuels would be considerably greater than that for gasoline on an energy equivalent basis--5.5 times greater for liquid methane and 3.5 times greater for hydrogen.

To liquefy methane and hydrogen for automotive fuel exacts a considerable energy penalty. For storage as a liquid, methane requires a temperature of 112K (-259°F), whereas hydrogen must be cooled to 20K (-423°F). To produce liquefied natural gas (LNG) from gas at pipeline pressure requires an amount of fuel equal to about 17% of the gas input.¹¹ Because the gas itself is typically used as a fuel in such liquefaction plants, this energy requirement affects the liquefaction efficiency, which is thus 0.83 because other losses are negligible. The indirect

energy requirements for plant construction and operation, plus a small electricity requirement, amount to 0.6×10^4 Btu per 10^6 Btu of liquefied methane.²³

For hydrogen, the liquefaction energy requirement is much higher because of the greater refrigeration requirement. The energy input required for hydrogen liquefaction is about 30% of the energy content of the hydrogen itself.²⁴ This figure varies with plant capacity, but it would be typical for the medium-size plants that would supply automobile filling stations. Typically, electricity supplies the energy for hydrogen liquefaction facilities. Referring the electricity consumption to fossil fuel requirements results in an overall consumption of resource energy of 1.1×10^6 Btu per 10^6 Btu of hydrogen liquefied. Indirect energy requirements are on the order of 1% of the hydrogen energy content and thus do not add appreciable amounts to the previous figure. The energy efficiency of liquefaction is essentially 1.0 because hydrogen boil-off is captured and reliquefied.

Fuel Distribution

The calculation of energy consumption for distributing fuels to their final use point is made difficult by the lack of data and the many variations in fuel distribution networks. In any case, requirements for this part of the system are likely to be small.

A calculation of fuel consumption for gasoline tank trucks delivering fuel in the Denver metropolitan area indicates that, on the average, 0.2×10^4 Btu of diesel fuel is consumed for every 10^6 Btu of gasoline delivered.⁴ This is equivalent to 0.24×10^4 Btu of resource energy. If the indirect-energy consumption in the fuel distribution system (including bulk storage facilities, tank trucks, and filling stations) is at most no greater than the direct fuel requirement, we may assume an upper limit of 0.5×10^4 Btu of energy consumed per 10^6 Btu of fuel delivered. Although some small losses take place in the system, we assume that the energy efficiency is essentially 1.0.

For methanol distribution, we assume twice the direct fuel requirement because of the low energy density of methanol. Thus, 0.7×10^4 Btu is consumed per 10^6 Btu of methanol delivered.

For liquid methane and hydrogen distribution, the energy requirements are somewhat greater because of the necessity of cryogenic storage facilities and tank trucks. In addition, boil-off from storage vessels results in greater energy losses. Storage of hydrogen in large cryogenic vessels suitable for filling stations (50,000 - 100,000 gal) results in boil-off losses on the order of 0.1% per day.¹² If an average storage time of 1 week and additional losses of 1% due to transfer and transportation are assumed, an energy efficiency of 0.98 seems reasonable. We assume a distribution efficiency of 0.99 for liquid methane because its boiling point is higher and its boil-off rate less.

We arbitrarily assume that the indirect energy requirements for liquid methane and hydrogen are about twice those for gasoline-- 1.0×10^4 Btu per 10^6 Btu delivered.

For electricity distribution, the main energy losses are in the step-down transformers that reduce the high line voltage used in long-distance transmission to the 110 V used in homes and businesses. These losses are included in the transmission and distribution efficiency of 0.91 discussed above. The indirect energy requirements are expected to be small--on the order of 0.1×10^4 Btu per 10^6 Btu delivered.

REFERENCES FOR APPENDIX D

1. E. M. Dickson, et al., "Synthetic Liquid Fuels Development: Assessment of Critical Factors," U.S. Energy Research and Development Administration Report ERDA 76-129/2.
2. A. J. Frabetti, et al., "A Study to Develop Energy Estimates of Merit for Selected Fuel Technologies," Development Sciences, Inc. (September 1975).
3. M. Rieber, et al., "The Coal Future: Economic and Technological Analysis of Initiatives and Innovations to Secure Fuel Supply Independence," Appendix F, University of Illinois Center for Advanced Computation Document No. 163 (May 1975).
4. "Net Energy Analysis: An Energy Balance Study of Fossil Fuel Resources," The Colorado Energy Research Institute (April 1976).
5. T. C. Aude, et al., "Slurry Pipeline Systems: Trends, Design Methods, Guidelines," Chemical Engineering, p. 74 (June 28, 1971).
6. J. K. Hogle, et al., "Manpower, Materials, and Capital Costs for Energy-Related Facilities," Bechtel Corporation (April 1976).
7. J. Pangborn and J. Gillis, "Alternative Fuels for Automotive Transportation--A Feasibility Study," Vol. III, Institute of Gas Technology, Environmental Protection Agency, EPA-460/3-74-012-C (July 1974).
8. "Western Gasification Company Coal Gasification Project and Expansion of Navajo Mine by Utah International, Inc., New Mexico," Final Environmental Statement, U.S. Department of the Interior (January 1976).
9. "El Paso Coal Gasification Project, New Mexico--Draft Environmental Statement," U.S. Department of the Interior (July 1974).
10. F. K. Chan, "A SASOL Type Process for Gasoline, Methanol, SNG and Low Btu Gas from Coal," M. W. Kellogg Company, Environmental Protection Agency, EPA-650/2-74-072 (July 1974).
11. "Environmental Impacts, Efficiency and Cost of Energy Supply and End Use," Vol. II, Hittman Associates, Inc. (November 1974).
12. E. M. Dickson, et al., The Hydrogen Energy Economy: A Realistic Appraisal of Prospects and Impacts (Praeger Publishers Inc., New York, 1977).
13. F. H. Kant, et al., "Feasibility Study of Alternative Fuels for Automotive Transportation," Exxon Research and Engineering Co., Environmental Protection Agency, EPA-460/3-74-001-b (June 1974).

14. E. E. Hughes, et al., "Long Term Energy Alternatives for Automotive Propulsion--Synthetic Fuel Versus Battery/Electric System," Stanford Research Institute (August 1976).
15. D. R. Stephens, "Revised Cost Estimate for the LLL In-Situ Coal Gasification Concept," Lawrence Livermore Laboratory Report UCRL-51578 (May 1974).
16. C. R. Adelman, et al., "The LLL In-Situ Coal Gasification Research Program in Perspective--A Joint GR & DC/LLL Report," Lawrence Livermore Laboratory and Gulf Research and Development Co., TID-26825 (June 1975).
17. A. Pasternak, "Methyl Alcohol Production by In-Situ Coal Gasification," Lawrence Livermore Laboratory Report UCRL-51600 (August 1974).
18. "Environmental Considerations in Future Energy Growth," Battelle Columbus Laboratories (April 1973).
19. "Report on Gulf Coast Deep Water Port Facilities--Texas, Louisiana, Mississippi, Alabama and Florida," U.S. Department of the Army, Corps of Engineers (June 1973).
20. R. A. Reynolds and W. L. Slager, "Pipeline Transportation of Hydrogen," in Hydrogen Energy, T. N. Veziroglu, ed. (Plenum Press, New York, 1975).
21. "Energy Alternatives: A Comparative Analysis," The Science and Public Policy Program, University of Oklahoma (May 1975).
22. Crude Petroleum, Petroleum Products, and Natural Gas Liquids: 1973," U.S. Bureau of Mines Mineral Industry Surveys--Annual Petroleum Statement (February 1975).
23. "The Supply-Technical Advisory Task Force--Liquified Natural Gas (LNG)," Federal Power Commission (March 1973).
24. W. R. Parrish and R. O. Voth, "Cost and Availability of Hydrogen," in "Selected Topics on Hydrogen Fuel," J. Hord, ed., National Bureau of Standards Report NBSIR 75-802 (January 1975).