

Colon

T
SIEX :

A CORRELATED CODE FOR THE
PREDICTION OF LIQUID METAL
FAST BREEDER REACTOR (LMFBR)
FUEL THERMAL PERFORMANCE

BY

D. S. Dutt and R. B. Baker *EA*

NOTICE

This report was prepared as an account of work sponsored by the United States Government. Neither the United States nor the United States Energy Research and Development Administration, nor any of their employees, nor any of their contractors, subcontractors, or their employees, makes any warranty, express or implied, or assumes any legal liability or responsibility for the accuracy, completeness or usefulness of any information, apparatus, product or process disclosed, or represents that its use would not infringe privately owned rights.

MASTER

NOTICE

PORTIONS OF THIS REPORT ARE ILLEGIBLE. It
has been reproduced from the best available
copy to permit the broadest possible avail-
ability.

Hanford Engineering Development Laboratory

Operated by the Westinghouse Hanford Company	A Subsidiary of Westinghouse Electric Corporation	for the United States Energy Research and Development Administration Contract No. EY-76-C-14-2170
--	---	--

~~DISTRIBUTION OF THIS DOCUMENT IS LIMITED~~
~~No Automatic Distribution of~~
Refer all requests to *HEDL EA*

DISTRIBUTION OF THIS DOCUMENT IS UNLIMITED

DISCLAIMER

This report was prepared as an account of work sponsored by an agency of the United States Government. Neither the United States Government nor any agency Thereof, nor any of their employees, makes any warranty, express or implied, or assumes any legal liability or responsibility for the accuracy, completeness, or usefulness of any information, apparatus, product, or process disclosed, or represents that its use would not infringe privately owned rights. Reference herein to any specific commercial product, process, or service by trade name, trademark, manufacturer, or otherwise does not necessarily constitute or imply its endorsement, recommendation, or favoring by the United States Government or any agency thereof. The views and opinions of authors expressed herein do not necessarily state or reflect those of the United States Government or any agency thereof.

DISCLAIMER

Portions of this document may be illegible in electronic image products. Images are produced from the best available original document.

Operated by
Westinghouse
Hanford Company
for the USAEC

A subsidiary of
Westinghouse Electric
Corporation

Contract number
AT(45-1)2170

P. O. Box 1970
Richland, WA 99352

Hanford Engineering Development Laboratory

INFORMATION CONCERNING USE OF THIS DOCUMENT

CONTROLLED DISTRIBUTION DOCUMENT

This is a working document required for internal HEDL laboratory use and program distribution in order to perform, direct or integrate the work of the LMFBF/FFTF program. Distribution is limited to HEDL, AEC, and AEC contractors who require the document in order to perform work required by HEDL. Its contents should not be published, further disseminated, or used for other purposes until approval for such release or use has been secured from HEDL Records Accountability.

PATENT STATUS

This document copy, since it is transmitted in advance of patent clearance, is made available in confidence solely for use in performance of work under contracts with the U.S. Atomic Energy Commission. This document is not to be published nor its contents otherwise disseminated or used for purposes other than specified above before patent approval for such release or use has been secured, upon request, from the RL Patent Attorney, Richland Operations Office, U.S. Atomic Energy Commission, Richland, Washington 99352.

NOTICE

This document was prepared as an account of work sponsored by the United States Government. Neither the United States nor the United States Atomic Energy Commission, nor any of their employees, nor any of their contractors, subcontractors, or their employees, makes any warranty, express or implied, or assumes any legal liability or responsibility for the accuracy, completeness or usefulness of any information, apparatus, product or process disclosed, or represents that its use would not infringe privately owned rights.

PRELIMINARY DOCUMENT

This document contains information of a preliminary nature prepared in the course of work under Atomic Energy Commission Contract AT(451)2170. This information is subject to correction or modification upon the collection and evaluation of additional data.

DISTRIBUTION OF THIS DOCUMENT IS UNLIMITED

SIEX

A CORRELATED CODE FOR THE PREDICTION OF
LIQUID METAL FAST BREEDER REACTOR (LMFBR) FUEL
THERMAL PERFORMANCE

D. S. Dutt and R. B. Baker

ABSTRACT

The SIEX computer program is a steady state heat transfer code developed to provide thermal performance calculations for a mixed-oxide fuel element in a fast neutron environment. Fuel restructuring, fuel-cladding heat conduction and fission gas release are modeled to provide assessment of the temperatures. Modeling emphasis has been placed on correlations to measurable quantities from EBR-II irradiation tests and the inclusion of these correlations in a physically based computational scheme.

SIEX is completely modular in construction allowing the user options for material properties and correlated models. Required code input is limited to geometric and environmental parameters, with a "consistent" set of material properties and correlated models provided by the code. The development of physically based correlations to model certain of the phenomena has resulted in a computer program which provides reliable estimates of thermal performance characteristics, yet requires a small amount of core storage and computer running time.

CONTENTS

	<u>PAGE</u>
ACKNOWLEDGEMENT	v
I. INTRODUCTION	1
II. CODE DESCRIPTION	3
III. INPUT/OUTPUT	5
AXIAL POWER, FLUX AND NEUTRON ENERGY PROFILES	9
MODEL INPUT OPTIONS	9
MATERIALS PROPERTIES OPTIONS	10
CARD INPUT	11
PARAMATER INPUT	11
SIEX OUTPUT	11
IV. MATHEMATICAL MODELS	27
FSINTR: FUEL TEMPERATURE CALCULATIONS	27
ROUTINES ASSOCIATED WITH THE FUEL THERMAL CONDUCTIVITY	31
CSINTR: CLADDING TEMPERATURE CALCULATIONS	32
CDELD: COMPUTATION OF DIMENSIGNAL CHANGES OF THE CLADDING MATERIAL	33
FDELD: COMPUTATION OF FUEL DIMENSIONAL CHANGES	36
PPRES: COMPUTATION OF PLENUM PRESSURE	37
V. CORRELATED MODELS	38
FSWEL: RESIDUAL GAP CORRELATION	41
HGAP: FUEL-CLADDING CONDUCTANCE	43
RADIANT HEAT TRANSFER	47
HEAT TRANSFER ACROSS A GAS FILLED EFFECTIVE GAP	47

CONTENTS (cont'd)

	<u>PAGE</u>
SOLID TO SOLID HEAT TRANSFER COMPONENT	48
GAS CONDUCTIVITY	49
ACCOMMODATION COEFFICIENT	49
CALCULATION OF INTERFACE PRESSURE	50
FUEL TO CLADDING HEAT TRANSFER CORRELATION	53
STRUCT: FUEL MICROSTRUCTURE (RESTRUCTING) CORRELATION	54
FISGAS: FISSION GAS RELEASE CORRELATION	57
VI. REFERENCES	66
APPENDIX	
A - GLOSSARY	69
B - MATERIAL PROPERTIES AND CORRELATION COEFFICIENT VALUES	77
C - COMPUTER CODE LISTING	82

FIGURES

<u>Figure No.</u>		<u>Page</u>
1.	SIEX Fuel Pin Geometry	4
2.	Primary Routine Call Sequence of SIEX	7
3.	SIEX Flow Chart	8
4.	SIEX Input Deck Set-up	12
5.	Fuel and Cladding Heat Transfer Geometry	28
6.	FSINTR Flow Chart	30
7.	CSINTR Flow Chart	34
8.	Data Field for Postirradiation Fuel-Cladding Gap Correlation	39
9.	Data Interaction and Usage for SIEX Correlations	40
10.	Postirradiation Gap Measurement	42
11.	Postirradiation Diametral Fuel-Cladding Gap Correlation	44
12.	Fuel-Cladding Postirradiation Gap Model	45
13.	Fuel-Cladding Heat Transfer Schematic	46
14.	Elastic Fuel-Cladding Mechanical Interaction Schematic	51
15.	SIEX Predicted Linear Heat Rate to Incipient Melt	55
16.	HGAP Flow Chart	56
17.	Equiaxed Grain Growth Correlation	58
18.	Columnar Grain Growth Correlation	59
19.	STRUCT Flow Chart	60
20.	Fission Gas Release Correlation	63
21.	Fission Gas Release Vs. Burnup	64
22.	FISGAS Flow Chart	65

TABLES

<u>Table</u>		<u>Page</u>
I.	Primary Routines In SIEX	6
II.	Description of SIEX INPUT	13
III.	SIEX Output	20
	B.1 Material Property and Correlation Coefficient Values	77
	B.2 Gas Conductivities	81

ACKNOWLEDGMENTS

A code strongly based on data is, of necessity, a result of the efforts of many disciplines and personnel. The authors wish to acknowledge the contribution of the Component Testing Section at HEDL who designed and executed the EBR-II tests and directed the postirradiation examinations from which the data were extracted. Their cooperation and assistance in data interpretation were necessary in all phases of the SIEX development. D. R. Wilson, R. J. Jackson, C. M. Cox, and R. D. Leggett were instrumental in the model development and checkout. Many of their ideas and procedures have been incorporated into SIEX.

I. INTRODUCTION

This documentation describes the SIEX computer program which is a fast running, steady state thermal performance code used to calculate coolant, cladding and fuel temperatures throughout the history of a fuel element. SIEX was developed by the Hanford Engineering Development Laboratory (HEDL) for performance analysis of mixed-oxide fuel pins irradiated under steady state fast flux conditions. Although versions of SIEX have existed at HEDL* since 1968, this is the first effort to place the current techniques used by the code at the disposal of a larger group of users.

It is necessary to have a method to accurately assess the thermal performance of a mixed-oxide fuel pin in a fast neutron environment. The resulting thermal analyses are the basis for:

- . subsequent steady state or transient stress analysis.
- . prediction of steady state or transient failure modes and times.
- . safety related accident analyses.

A code with short running times and relatively small storage requirements is needed in order to be routinely used as a test design/analysis tool or to define initial conditions for a more detailed subsequent analysis.

SIEX is constructed of a series of moduls with a single set of dimensional units used throughout to provide flexibility in model usage and ease of upgrading as models developed from future tests are finalized. Radial steady state heat transfer can be computed for 21 axial segments. The code computes all major quantities which affect the thermal performance (restructuring, fission gas generation and release, etc.) Code running times are typically two to five seconds per case on the Control Data Corporation CYBER-74. The running time is dependent on the output refinement required by the user. The amount of core storage required is 50K octal (20K decimal) of 60 bit CYBER words. No peripheral storage is required, subject to the input/output devices selected by the user.

The documentation is also in modular form so that an update or modifica-

*Prior to 1970, the Pacific Northwest Laboratory, operated by Battelle Mem. Inst.

tion to any of the correlated (and if necessary, mathematical) models can be made without disturbing the rest of the document. The first section is a user's manual which describes the input/output subroutines and user options. Directions for the code usage in its present form and sample cases are given at the end of this section. The second and third sections, respectively, provide flow charts and descriptions or brief derivations of the mathematical and correlated models. Much of the code checkout and confirmation is contained in the last section where the correlations to observations are presented.

II. CODE DESCRIPTION

SIEX is a computer code which calculates the thermal performance characteristics and dimensional changes (swelling and thermal expansion) of mixed oxide fuel pins in a fast neutron environment. SIEX is comprised of a series of subroutines which model certain fast reactor fuels phenomena and is correlated to a significant amount of EBR-II irradiation test data. Program development and numerical techniques have been carried out in a way which provides a code with short running times and modular independence of models. The code satisfies the need for a data analysis and design tool in the LMFBF program.

The fuel pin is geometrically modeled as shown in Figure 1. The fuel column is divided axially into a user specified number of segments with equal height (equal fuel volume). One dimensional radial heat transfer is assumed at the axial center of each of these segments. The heat generated in each segment and released fission gas is accumulated over the segments for calculation of coolant temperatures and plenum pressure. For each segment, the following calculations are performed:

- . Coolant temperature
- . Cladding surface temperatures
- . Fuel-cladding heat transfer coefficient
- . Fuel temperatures
- . Fuel restructuring radii
- . Fuel and cladding displacements due to swelling and thermal expansion
- . Fission gas generated and released.

The number of time (burnup) increments is left to the discretion of the code user. For each time increment, the fission gas release is updated, the plenum pressure is computed, and the fuel temperatures are adjusted to account for the changing gap conductance. SIEX results are independent of the step size.

The SIEX code consists of a "driving" routine, input/output routines, mathematical models, and physically-based correlated models. The mathematical models are heat transfer, gas pressure and, to a certain extent, dimensional

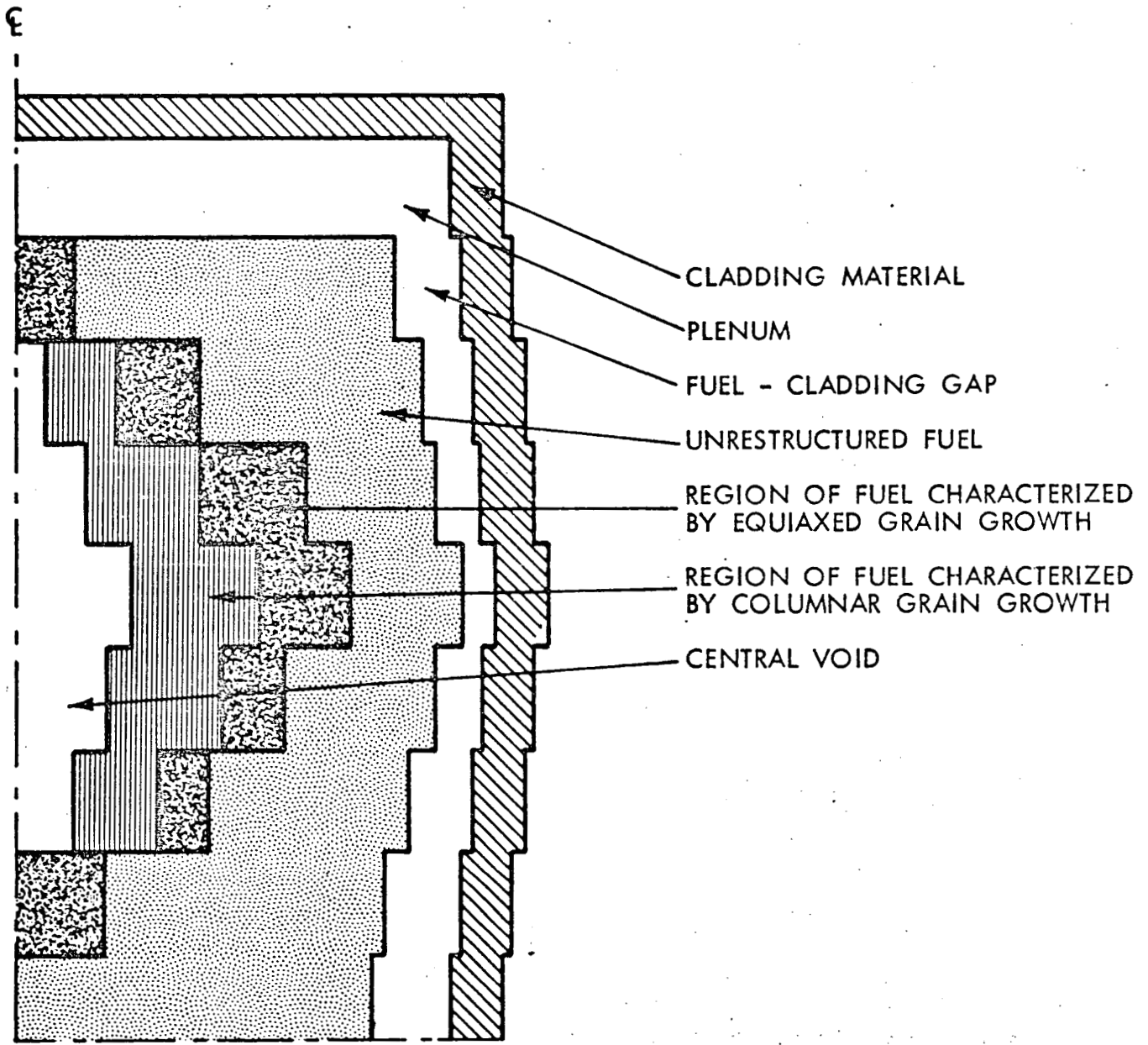

HEDL 7412-23.2

FIGURE 1. SIEX Fuel Pin Geometry.

changes of the fuel and cladding. A brief explanation or derivation of these models is included in this document for completeness. For the correlated models (gas release, restructuring, etc.), a summary is made of the data used in the correlation, a rationale for the models, and a model description. In most cases, these models can be updated or entirely replaced with little effect on the rest of the code mechanics. All internal coding is in cgs units. "Convenience unit" conversions are handled in the input and output subroutines.

The primary routines are listed in Table 1 along with a description of their usage. In those cases where auxiliary routines are used, they are listed. Figure 2 is a diagram of the routine call sequence. Figure 3 is a SIEX flow chart.

III. INPUT/OUTPUT

The Input/Output routines are a compromise between user convenience and code flexibility. "Overrides" to data values programmed into the code provide for new or extended applications of the code which necessitate modification. The first portion deals with those assumptions which may be considered input, but are programmed into SIEX for its use as an EBR-II test design/analysis code and an FFTF fuel pin performance analysis tool. The card input procedure will then be discussed with attention given to the options provided to the user.

TABLE I
PRIMARY ROUTINES IN SIEX

<u>ROUTINE NAME</u>	<u>DESCRIPTION</u>	<u>ROUTINES CALLED</u>
<u>MAIN SIEX</u>		
<u>Physical Models</u>		
FSINTR	Computes the radial temperature distribution across the fuel pellet using a two zone heat transfer model. The integral kdt is computed by the function S, and fuel-cladding heat transfer coefficients have been computed by HGAP.	STRUCT, S, T RFIND
CSINTR	Computes the coolant axial temperature rise and the temperatures of the inner and outer cladding surfaces.	SINPUT
CDELD	Computes the cladding geometry during irradiation, considering deformations due to swelling and thermal expansion.	
FDELD	Computes the fuel outer radius due to fuel thermal expansion and correlated permanent deformations as computed by FSWEL.	FSWEL
PPRES	Computes the plenum pressure based on the perfect gas law.	
<u>Correlated Models</u>		
HGAP	Computes fuel-cladding gap conductance based on a modified Ross-Stout model.	FSINTR, CONMIX, FDELD, PPRS, FISSGAS
FISSGAS	Computes fission gas generated and released.	
STRUCT	Computes the restructuring radii of the fuel.	S, T, RFIND
FSWEL	Computes the permanent fuel deformations	
<u>Input-Output</u>		
INPUT	Reads input in "engineering" units converts to cgs.	SPAGE, FISSGAS, FDELD
OUTPUT	Converts cgs units to "engineering" units and prints selected output tables.	SPAGE

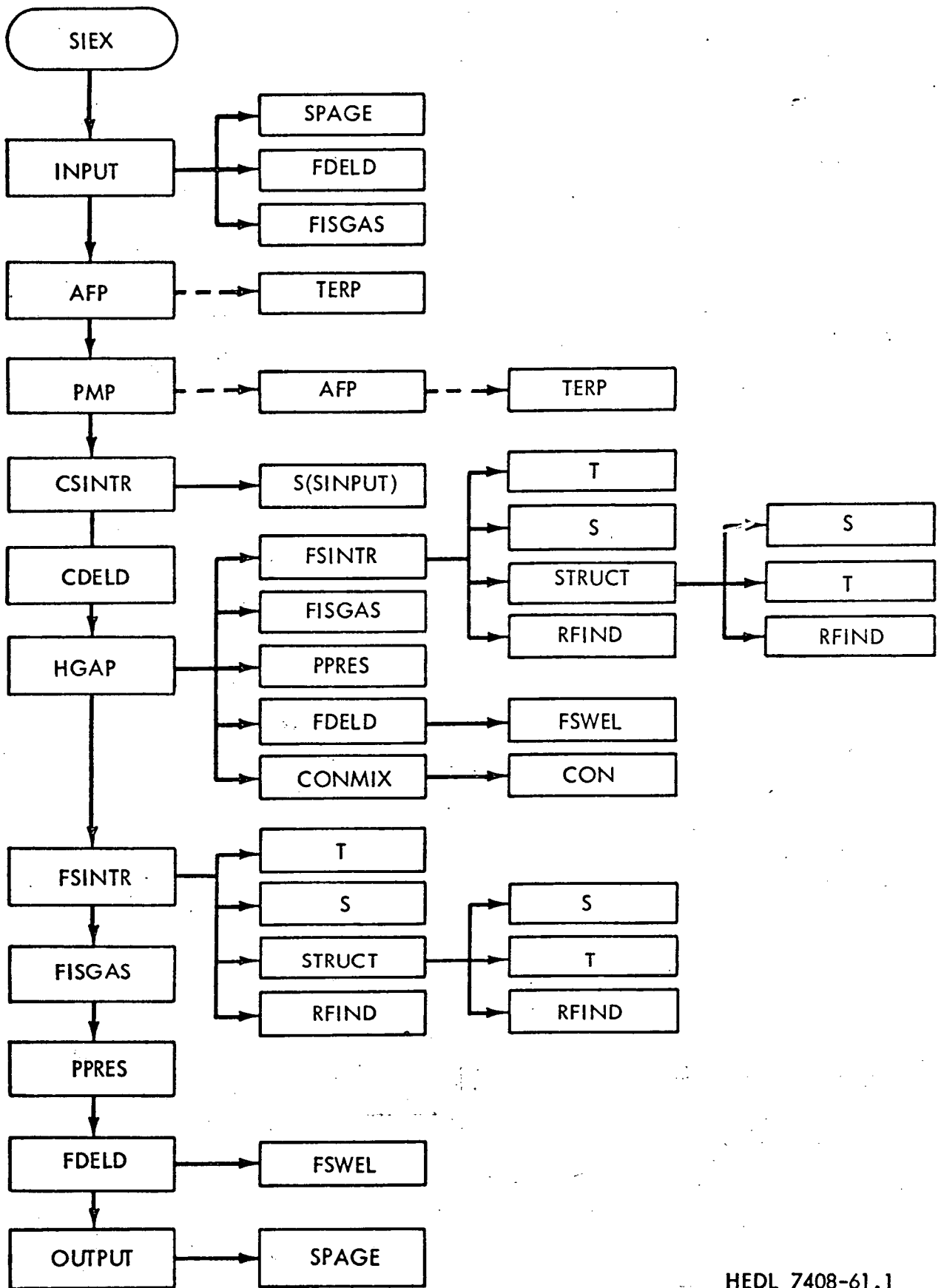

HEDL 7408-61.1

FIGURE 2. Primary Routine Call Sequence of SIEX.

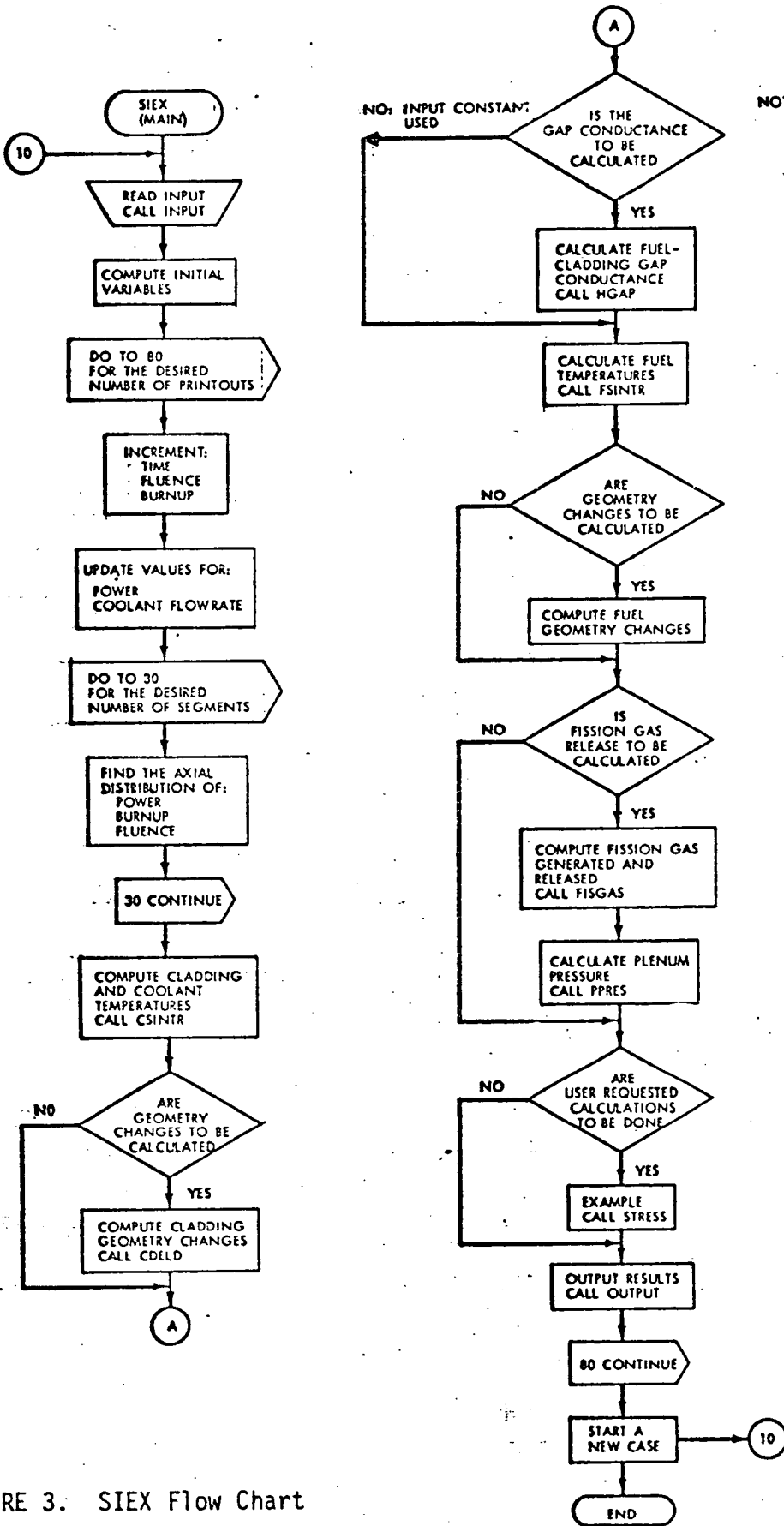

NOTE: IF DIAMETER CHANGES, OR FISSION GAS CALCULATIONS ARE NOT REQUIRED, THE GAP CONDUCTANCE CALCULATIONS WILL NOT BE DONE

FIGURE 3. SIEX Flow Chart

VALUES WHICH CAN BE SUPPLIED BY THE CODE

Axial Power, Flux and Neutron Energy Profiles

The axial flux profile is supplied by the function AFP, the power profile by PMP, the average neutron energy by EBR, and the ratio of flux greater than 0.1 MeV to total neutron flux by FTX. In the cases of AFP and PMP, the profiles are normalized to the peak values. FTX and EBR return the actual values. Four options are available to the user:

1. Axial power and flux profiles are identical "chopped" cosine curves with an extrapolation distance, E, specified by the user (Reference 1). The average neutron energy and the ratio of flux greater than 0.1 MeV to the total neutron flux are assigned the values consistent with EBR-II Operation.

2. The values for the power and flux profiles are interpolated from a user-supplied table of data and assumed to have the same shape. The data table is programmed into the code as a data statement in BLKDAT. As in the first case, the average neutron energy and ratio of flux greater than 0.1 MeV to total flux are assigned constant values.

3. The user may specify a functional form to be evaluated for each of the functions. Examples of quadratics, which were obtained by analyzing certain EBR-II gamma scan data, are presently programmed. No significance should be attached to these correlations which serve as examples only.

4. All four values may be interpolated from tables of values supplied by the user through input. This will be explained in the section on card input.

Model Input Options

1. Fission gas release can be evaluated either by the fission gas release model discussed in Section III or a three region model in which the fraction released for each region is supplied by the user. The three regions of the user-supplied gas release fraction are assumed to be the fuel region characterized by columnar grain growth, the fuel region characterized by equiaxed grain growth, and the unstructured fuel region. The fractional release for the user supplied case is assumed to be independent of burnup or in-reactor time.

2. The temperatures, in degrees Centigrade, which are used to predict the observed radial extent of columnar and equiaxed grain growth, may be taken as those presented in Section III or user-supplied values.

3. The fuel-cladding gap conductance model discussed in Section III may be replaced by a user-supplied constant.

In all of the above cases, the models were developed on a systematic basis, a user "override" should be used only after consideration of its effect on the other models, e.g., an "override" of the gas release model may be useful in determining maxima for pressure and temperatures, but an override on restructuring may give erroneous results for gas release and gap conductance.

Material Properties Options

Values for the material properties used in SIEX have been coded into the BLKDAT routine. However, these may be changed by the user through card input.

Those material properties which may be changed by the user are:

1. Cladding thermal expansion coefficient: The SIEX code assumes that the mean coefficient of thermal expansion is $\alpha^C = \alpha_0^C + \alpha_T^C \times T$, where T is temperature in $^{\circ}\text{C}$ and α^C is the coefficient of thermal expansion, $\text{cm}/\text{cm}^{\circ}\text{C}$.

2. Young's modulus of the cladding: SIEX assumes $E^C = E_0^C + E_T^C \times T$, where T is temperature in $^{\circ}\text{C}$, and E^C is Young's modulus in dynes/cm^2 .

3. Poisson's ratio for the cladding which is a constant.

4. Cladding thermal conductivity: This may be input as a constant as described in card input section. If no input is encountered, SIEX assumes a temperature dependent conductivity of $K^C = K_0^C + K_T^C \times T$, where K^C is in $\text{watts}/\text{cm}^{\circ}\text{C}$ and T is in $^{\circ}\text{C}$. A single iteration of the temperature dependence is programmed into the evaluation of the conductivity equation, i.e.,

$$K^C = K_0^C + K_T^C \left[T_0^C + \frac{.5t \times q_l}{2\pi(r_0^C - 0.5t)(K_0^C + K_T^C \times T_0^C)} \right]$$

where $\frac{.5t \times q_l}{2\pi(r_0^C - 0.5t)(K_0^C + K_T^C \times T_0^C)}$ is, of course, a temperature correction

to the initial estimate of the cladding temperature, T_0^C . T_0^C is the cladding surface temperature, q_c heat rate, r_0^C cladding radius, and t is the cladding thickness.

The fuel properties for thermal expansion and Young's modulus are of the form

$$\alpha^f = \alpha_0^f + \alpha_T^f \times T, \text{ cm/cm} - ^\circ\text{C}$$

$$E^f = E_0^f + E_T^f \times T, \text{ dynes/cm}^2,$$

respectively, where T is temperature $^\circ\text{C}$. No "override" options are provided via input but these values may be changed by changing the block data routine.

Card Input

Card input is by NAMELIST input. Though this does not conform to ANSI standard, its user convenience is justification for its use. NAMELIST input is free field, non-formatted,* and does not require that all variables be input when multiple cases are run. For parametric studies, only a title card and the variables of interest need to be input. The NAMELIST variable is IPT. A typical input deck with a series of cases would be set up as shown in Figure 4. Table II is a listing of the NAMELIST variables (and code variables), units, and a description of each.

Parameter Input

Values for parameters in correlated models and coefficients for material properties are transferred to the code through labeled common. These values are placed in memory in the block data routine BLKDAT by means of data statements. This centralization of code parameters eliminates the need to change entire blocks of code when changing values for the model. The routine itself is well "commented" to assist in making any desired changes.

OUTPUT

SIEX output is structured to produce a series of "tables" dealing with a particular model or calculational procedure. Explanation of the output is accomplished by example. Table III is the computer-generated output for the first deck listed in Figure 4 of the input description.

* The sequence or position of the variables in Figure 4 is not important.

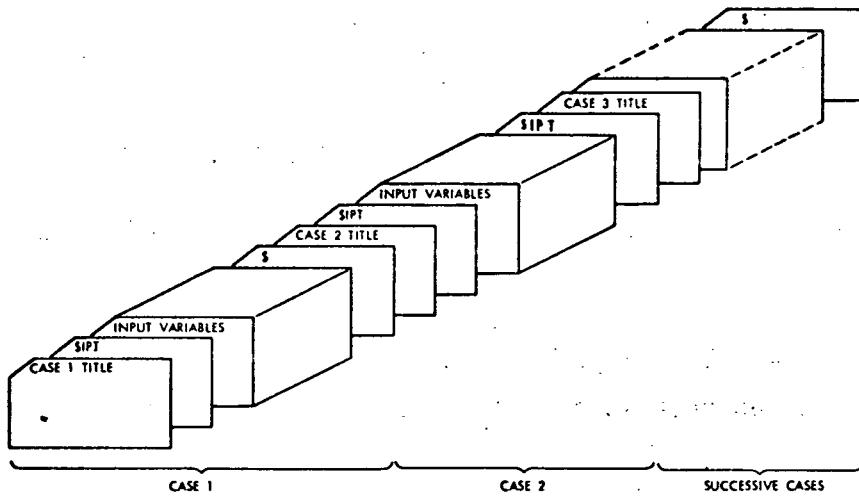

SIEX TEST CASE NO. 1 - ALL DEFAULT USER OPTIONS

SIPT FLEN = 13.52, E	= 0.00, FD	= 0.1935, VOID	= 0.000,
DP = 0.2300, CT	= 0.0153, PM	= 12.160, CMF	= 779.8,
HF = 30000, HG	= 1700, TI	= 700.0, TB	= 0.,
TEMP2 = 0., DENLO	= .9086, DENHI	= 9800, TD	= 11.96,
SEGNUM = 10., PBU	= 2214., EFPD	= 0., STEPS	= 0.,
Z1 = 1., Z2	= 1.23	= -1., CCPGM	= 0.02,
PPM = 15.00, EPL	= 11.15, XEFIL	= 11.500, KRFIL	= 0.00,
TMSWC = 2., EXTERP	= 35.0, ITAB1	= 1, ITAB2	= 1,
ITAB3 = 1, ITAB4	= 1, PFLUX	= 2.0 E15,	
\$			

SIEX TEST CASE NO. 2 - READ AXIAL PROFILES AND TIME STEP CONTROLS

SIPT E = -11., STEPS = -2.,
 THINCR (1) = 5.04, 5.60,
 PRATIO (1) = 1., .90,
 CRATIO (1) = 1., .90,
 READX (1) = 0, 0.1, 0.2, 0.3, 0.4, 0.5, 0.6, 0.7, 0.8, 0.9, 1.0,
 READPF (1) = .781, .857, .924, .970, .997, .995, .970, .923, .860, .788, .751,
 READP (1) = .781, .857, .924, .970, .997, .995, .970, .923, .860, .788, .751,
 READER (1) = 11*.85,
 READTF (1) = 11*.85,
 \$

SIEX TEST CASE NO. 3 - OVER RIDE THE PROGRAMMED MATERIAL PROPERTIES

SIPT CK = 11.4, CP = 0.305, ALPHA0=9.10E-6, ALPHAS=1.25E-9,
 YMO0=2.15E7, YMODS=0.0, PNM=3,
 \$

NECL 7409-81.1

FIGURE 4. SIEX Input Deck Set-Up.

TABLE II
DESCRIPTION OF SIEX INPUT

Input Parameter Name	Definition of Parameter	Input Units
FLEN	Active fuel column length	inches
E	The value of E provides the axial flux and power profiles as follows: $E > 0$ (E is the extrapolation distance for a "chopped" cosine curve) $E = 0$ (Interpolate from internally supplied data tables) $0 > E \geq -1$ (Evaluate user-supplied functions) $E < -1$ (Interpolate from a user supplied table which is read from input, $ E $ values are expected)	inches
FD	Fuel diameter	inches
VOID	Fuel (fabricated) central annulus diameter	inches
DP	Cladding outer diameter	inches
CT	Cladding wall thickness	inches
PM	Maximum pin heat rate	kW/ft
CMF	Coolant mass flow rate	lb/hr
CP	Coolant specific heat (If no namelist input is supplied, the SIEX supplied value of CP is used)	Btu/lb-°F
HF	Cladding-to-coolant heat transfer coefficient	Btu/ft ² -°F-hr

TABLE II (Continued)
DESCRIPTION OF SIEX INPUT

Input Parameter Name	Definition of Parameter	Input Units
HG	Fuel-to-cladding heat transfer coefficient (also used as an initial estimate for subsequent gap conductance calculations)	Btu/ft ² - °F-hr
CK	Cladding thermal conductivity CK > 0 (the value of CK is used independent of temperature) CK ≤ 0 (the SIEX programmed temperature-dependent conductivity is used)	Btu/ft-hr-°F
TI	Inlet coolant temperature	°F
TB	Temperature to use for the prediction of the columnar grain growth radius TB > 0 (the value of TB is used in making the prediction of the columnar grain growth radius) TB ≤ 0 (the SIEX programmed value is used to predict the columnar grain growth radius)	°C
TEMP2	Temperature to use for the prediction of the equiaxed grain growth radius TEMP2 > 0 (the value of TEMP2 is used to predict the equiaxed grain growth radius) TEMP2 ≤ 0 (the SIEX programmed value is used to predict the equiaxed grain growth radius)	°C
DENLO	Fraction of theoretical density of the fabricated fuel	
DENHI	Fraction of theoretical density of the fuel in the columnar grain growth region	

TABLE II (Continued)

Input Parameter Name	Definition of Parameter	Input Units
TD	Fuel theoretical density	gm/cc
DISH	Fraction of the fuel volume (pellet or total column volume) which is occupied by voidage due to fabricated end dishes in the fuel pellets.	fraction
Pu	Fraction of the metal in the fuel which is Pu ²³⁹ or Pu ²⁴¹ .	fraction
U ²³⁵	Fraction of the metal in the fuel which is U ²³⁵ .	fraction
SEGNUM	Number of axial segments desired. An additional node at the top of the fuel pin is added by SIEX (maximum value for SEGNUM is 21)	
PBU	Peak burnup to be achieved (needs to be specified if EFPD, below, is zero, otherwise is overridden by computed burnup)	Mwd/MTM
EFPD	Final time, effective full power days EFPD > 0 (EFPD, calculated fuel weight, and PM are used to compute burnup) EFPD = 0 (burnup, calculated fuel weight, and PM are used to compute EFPD)	EFPD
STEPS	Output burnup and time increments as follows: STEPS < 0 The STEPS values for time increments at which output is desired will come from input values (may be unequal). See TIINCR STEPS = 0 (output peak burnup results only) STEPS = 1 (output zero and peak burnup results) STEPS > 1 (output results at zero burnup, peak burnup, and at each PBU/STEPS interval)	

TABLE II (Continued)

Input Parameter Name	Definition of Parameter	Input Units
	This STEPS logic pertains to EFPD in the same manner as it does to PBU if EFPD is used for time dependency.	
Z1	Fraction of fission gas release from fuel columnar region	fraction
Z2	Fraction of fission gas release from fuel equiaxed region	fraction
Z3	Fraction of fission gas release from unstructured region	fraction
	Z3 < 0 (calculate using fission gas release model)	
CCPGM	Sorbed gas from fabrication per gram of fuel exclusive of water vapor	cc(STP)/gm oxide
FN	Fraction of sorbed gas which is not Helium or Hydrogen. This gas is assumed to have the thermal conductivity of nitrogen.	fraction
PPM	Parts per million water vapor in the fabricated fuel	ppm
EPL	Effective plenum length	inches
XEFIL	Percent xenon tag in the fill gas	percent
KRFIL	Percent krypton tag in the fill gas	percent
ALPHA0	The coefficient of cladding thermal expansion (α^C) is assumed to be linear with temperature (T) increase. In the expression $\alpha^C = \alpha_0^C + \alpha_T^C$, ALPHA0 is the intercept, α_0^C . (If no namelist input is supplied, the SIEX value of ALPHA0 is used)	in/in-°F
ALPHAS	In the expression above, ALPHAS is the slope, α_T^C . (If no namelist input is supplied, the SIEX value of ALPHAS is used)	in/in-°F ²
YMOD0	Young's modulus (E) is also assumed to be linear with temperature (T) increase. In the expression $E^C = E_0^C + E_T^C$, YMOD0 is the intercept, E_0^C . (If no namelist input is supplied, the SIEX value of YMOD0 is used)	lb/in ²

TABLE II (Continued)

Input Parameter Name	Definition of Parameter	Input Units
YMODS	In the expression above, YMODS is the slope, E_c . (If no namelist input is supplied, the SIEX value of YMODS is used)	lb/in ² -°F
PNU	Cladding Poisson's ratio (If no namelist input is supplied, the SIEX value of PNU is used.)	
PFLUX	Peak flux (neutrons with energy < 0.1 MeV).	N/cm ² -sec
TMSWC	Switch for desired cladding swelling model as follows: <p style="margin-left: 40px;">TMSWC = 1.0 (304 annealed ss)</p> <p style="margin-left: 40px;">TMSWC = 2.0 (306 annealed ss)</p> <p style="margin-left: 40px;">TMSWC = 3.0 (316 20% cold worked ss)</p>	
EXTERP	External pressure	psig
ITAB1	Fission gas release and plenum pressure option: <p style="margin-left: 40px;">ITAB1 = 0 (no calculations and no output)</p> <p style="margin-left: 40px;">ITAB1 = 1 (calculations and output results)</p>	*
ITAB2	Fuel and cladding diameter increase option: <p style="margin-left: 40px;">ITAB2 = 0 (no calculations and no output)</p> <p style="margin-left: 40px;">ITAB2 = 1 (calculations and output results)</p>	*
ITAB3	Fuel-cladding heat transfer coefficients calculation option: <p style="margin-left: 40px;">ITAB3 = 0 (use input HG as a constant)</p> <p style="margin-left: 40px;">ITAB3 = 1 (calculation of the gap coefficient)</p>	*

* ITAB1 through ITAB4 are the only namelist input variables which are FORTRAN integers.

TABLE II. (Continued)

Input Parameter Name	Definition of Parameter	Input Units
ITAB4	Cladding elastic stress option: ITAB4 = 0 (no calculations - no output) ITAB4 = 1 (calculations and output results)	*
TIINCR	If STEPS is less than zero, the time increments at which output and calculations are desired. STEPS values are required. (10 maximum)	
PRATIO	The ratio of power to the input peak power (PM) during the corresponding time increment of above (10 maximum.) At time zero PM is used.	
CRATIO	The ratio of the coolant mass flow rate to the input value (CMF) during the corresponding time increment of above (10 maximum). At time zero CMF is used.	
READX	If $E < -1$, the positions along the length of the pin at which power, flux, average neutron energy and ratio of flux > 0.1 MeV to total flux are to be read to form tables for interpolation. Values of READX are to be normalized to FLEN. E values of READX are required.	
READFP	Axial flux profile (relative to PFLUX) corresponding to the locations in READX. E values of READFP are required.	
READP	Axial power profile (Relative to PM) corresponding to the locations in READX. E values of READP are required.	
READEB	Axial distribution of average neutron energy corresponding to locations in READX. E values of READEB are required.	MeV
READTF	Axial distribution of the ratio of neutrons with energy greater than 0.1 MeV to the total neutron flux. E values of READTF are required.	

The descriptions of the different parts of Table III are:

Part 1 is a listing of all input variables along with a description of each variable and its units. If the user provides either the axial profiles or the time increment controls, additional output listing the input quantities will be added to Part 1. An example of this additional output can be obtained from the second example listed in the input description.

Part 2 is a listing of the predicted coolant temperature, cladding and fuel boundary temperatures, power, and gap conductance for all axial nodes. The variables listed here are produced by the routines CSINTR, FSINTR, and HGAP.

Part 3 is a listing of the predicted fuel microstructure, melting location (if one exists), and the temperatures at which the fuel restructuring is evaluated for each axial location. The variables listed in Part 3 are produced by the routines STRUCT and FSINTR.

Part 4 is the fuel radial temperature distribution for each axial position. These temperatures are computed in the routine FSINTR.

Part 5 deals with the gaseous fission products and gas components used in computing the plenum pressure and fuel-cladding heat transfer coefficient. An axial and radial distribution of fission gas generated, released, and retained is provided. A summary of the origin of the gas components in the plenum (and fuel-cladding gap) as well as the plenum pressure is given. The variables are computed in FISGAS and PPRES.

Part 6 provides the predicted fuel and cladding dimensional changes at all axial positions. Fuel permanent deformations, cladding swelling, and fuel outer postirradiation radius, may be obtained from the columns labeled "cladding swelling %" and "fuel-cladding cold gap." All other values in this part are in the "hot" condition, that is, they include the calculated thermal expansion. The values in this part are computed in CDELD and FDELD.

Part 7 is an example of the method used to generate output required by the user. Part 7 is a calculation of thermal and pressure (combined) cladding stresses using thick-walled stress equations. These are computed by the routine STRESS.

Table III
SIEX OUTPUT

SIEX -- REF MEDL-TME 74-55

SIEX TEST CASE NO.1 -- ALL DEFAULT USER OPTIONS
----- SIEX ANALYSIS -----

DATE 03/12/75

INPUT PARAMETERS USED FOR THIS ANALYSIS

DESCRIPTION	NAME	VALUE	
ACTIVE FUEL COLUMN LENGTH	FLEN	1.3520E+01	IN
EXTRAPOLATION DISTANCE	E	0.	IN
FUEL DIAMETER	FD	1.9350E-01	IN
FUEL CENTRAL ANNULUS DIAMETER	VOID	0.	IN
PIN DIAMETER	DP	2.3000E-01	IN
CLADDING THICKNESS	CT	1.5300E-02	IN
MAXIMUM PIN HEATING RATE	PH	1.2160E+01	KW/FT
COOLANT MASS FLOW RATE	CHF	7.7980E+02	LB/MR
COOLANT SPECIFIC HEAT	CP	3.0506E-01	BTU/LB-DEG F
FILM COEFFICIENT	HF	3.0000E+04	BTU/FT**2-DEG F-MR
GAP COEFFICIENT	HG	1.7000E+03	BTU/FT**2-DEG F-MR
CLADDING CONDUCTIVITY	CK	0.	BTU/FT-DEG F-MR
INLET COOLANT TEMPERATURE	TI	7.0000E+02	DEG F
TEMP. AT COLUMNAR (SINTERING) BOUNDARY	TB	0.	DEG C
TEMP. AT EQUIAXED GRAIN BOUNDARY	TEMP2	0.	DEG C
FRACTION OF THEORETICAL DENSITY-UNSIPTRO	DENLO	9.0260E-01	
FRACTION OF THEORETICAL DENSITY-SINTERED	DENHI	9.8000E-01	
FUEL THEORETICAL DENSITY	TD	1.1960E+01	GM/CC
FRACTION OF FUEL VOLUME OCCUPIED BY DISH	DISH	1.0000E-02	
FRACTION OF METAL WHICH IS PU239 + PU241	PU	2.5000E-01	
FRACTION OF METAL WHICH IS URANIUM 235	U235	0.	
NUMBER OF AXIAL SEGMENTS	SEGNM	1.0000E+01	
PEAK BURN UP	PBU	2.2140E+03	MWD/MTM
OPERATING TIME-EFFECTIVE FULL POWER DAYS	EPFD	0.	DAYS
NUMBER OF CALCULATIONS/PRINTOUTS	STEPS	0.	
FISSION GAS RELEASE - COLUMNAR ZONE	Z1	1.0000E+00	FRACTION
FISSION GAS RELEASE - EQUIAXED ZONE	Z2	1.0000E+00	FRACTION
FISSION GAS RELEASE - UNRESTRUCTURED ZONE	Z3	-1.0000E+00	FRACTION
SURRED GAS PER GRAM OF FUEL	CCPGM	2.0000E-02	CC/GM
FRACTION OF SCORDED GAS WHICH IS NITROGEN	FN	1.0000E-01	
PARTS PER MILLION WATER VAPOR	PPM	1.5000E+01	
EFFECTIVE PLENUM LENGTH	EPL	1.1150E+01	IN
PERCENT OF XENON IN THE FILL GAS	XFIL	1.1300E+01	
PERCENT OF KRYPTON IN THE FILL GAS	KFIL	0.	
COEF LINEAR EXPANSION - INTERCEPT	ALPHA0	9.0000E-06	IN/IN-DEG F
COEF LINEAR EXPANSION - SLOPE	ALPHA5	1.1700E-09	IN/IN-(DEG F)**2
YOUNGS MODULUS - INTERCEPT	YMOD0	3.0800E+07	LR/IN**2
YOUNGS MODULUS - SLOPE	YMOD5	-7.3470E+03	LB/IN**2-DEG F
POISSONS RATIO	PRU	3.0000E-01	
PEAK FLUX (ENERGY > .1 MEV)	PFLUX	2.0000E+15	NEUT/CM**2-SEC
MATERIAL(1=ANNEALED TYPE 304 SS 2=ANNEALED-TYPE 316 SS 3=20% CW TYPE 316 SS)	TMS=C	2.0000E+00	
EXTERNAL PRESSURE	EXTERP	3.5000E+01	PSIG
FISSION GAS RELEASE/PLENUM PRESS. OPTION	ITAB1	1.0000E+00	1=CALC 0=BYPASS
PIN DELTA D/D OPTION	ITAB2	1.0000E+00	1=CALC 0=BYPASS
HOT GAP COEFFICIENT OPTION	ITAB3	1.0000E+00	1=CALC 0=ENG FROM ABOVE IS USED
ELASTIC STRESS OPTION	ITAB4	1.0000E+00	1=CALC 0=BYPASS

** INPUT OPTIONS OR CODE SUPPLIED VALUES CAN BE USED. SEE THE USERS MANUAL IN MEDL-TME 74-55.

Table III (Cont'd)

SIEX OUTPUT

TIME 9.55 PEAK BURN UP 2218. SIEX TEST CASE NO.1 -- ALL DEFAULT USER OPTIONS PAGE 2

AXIAL SEGMENT NUMBER	DIST FROM BOTTOM OF FUEL, IN	COOLANT TEMP, DEG F	CLAD OD TEMP, DEG F	CLAD ID TEMP, DEG F	FUEL OUTER SURF TEMP, DEG F	RESTRUC FUEL INNER SURFACE TEMP, DEG F	SEGMENT POWER, KW/FT	FUEL-CLAD GAP COEF, BTU/FT**2-HR-F
1	.676	708.	727.	799.	1556.	3461.	9.96	860.
2	2.028	725.	745.	823.	1529.	3537.	10.82	1002.
3	3.380	743.	765.	847.	1509.	3595.	11.56	1150.
4	4.732	762.	785.	869.	1485.	3633.	12.01	1275.
5	6.084	781.	804.	889.	1492.	3655.	12.16	1320.
6	7.436	801.	824.	907.	1520.	3665.	12.00	1279.
7	8.788	820.	842.	921.	1569.	3658.	11.53	1164.
8	10.140	838.	859.	933.	1622.	3632.	10.87	1031.
9	11.492	855.	874.	943.	1674.	3582.	10.06	899.
10	12.844	871.	888.	951.	1712.	3520.	9.27	797.
TOP	13.520	878.	895.	957.			9.13	

Table III (Cont'd)

SIEX OUTPUT

TIME 9.55 PEAK BURN UP 2214. SIEX TEST CASE NO.1 -- ALL DEFAULT USER OPTIONS

PAGE 3

AXIAL SEGMENT NUMBER	DIST FROM BOTOM OF FUEL, IN	FUEL EQUIAXED ZONE RADIUS, INCHES	EQUIAXED TEMP, DEG C	FUEL COLUMNAR ZONE RADIUS, INCHES	COLUMNAR TEMP, DEG C	RADIUS OF MELTED FUEL, INCHES	FUEL CENTRAL VOID RADIUS INCHES
1	.676	.0675	1570.	.0588	1726.	0.0000	.0159
2	2.028	.0711	1570.	.0644	1712.	0.0000	.0174
3	3.380	.0736	1570.	.0680	1700.	0.0000	.0184
4	4.732	.0750	1570.	.0700	1693.	0.0000	.0189
5	6.084	.0757	1570.	.0709	1701.	0.0000	.0191
6	7.436	.0758	1570.	.0709	1693.	0.0000	.0191
7	8.788	.0752	1570.	.0697	1701.	0.0000	.0188
8	10.140	.0740	1570.	.0676	1711.	0.0000	.0182
9	11.492	.0718	1570.	.0639	1724.	0.0000	.0173
10	12.844	.0690	1570.	.0592	1737.	0.0000	.0160

Table III (Cont'd)

SIEX OUTPUT

TIME	9.55	PEAK	BURN UP	2214.	SIEX TEST CASE NO.1 -- ALL DEFAULT USER OPTIONS							PAGE 4
		.097	.087	.077	.068	RADIUS (INCHES)		.039	.029	.019	.010	
		1.000	.810	.640	.490	(RADIUS/OUTER RADIUS)**2		.160	.090	.040	.010	
SEC	INCH					TEMPERATURE (FAHRENHEIT)						
1	.676	1556.	1914.	2260.	2606.	2908.	3119.	3283.	3397.	3456.	3461.	
2	2.028	1529.	1916.	2303.	2674.	2968.	3192.	3365.	3481.	3536.	3537.	
3	3.380	1500.	1910.	2325.	2722.	3008.	3245.	3425.	3544.	3595.	3595.	
4	4.732	1485.	1910.	2342.	2740.	3016.	3280.	3464.	3585.	3633.	3633.	
5	6.084	1492.	1923.	2362.	2758.	3058.	3303.	3488.	3609.	3655.	3655.	
6	7.436	1520.	1951.	2387.	2780.	3074.	3318.	3501.	3621.	3665.	3665.	
7	8.788	1569.	1990.	2411.	2799.	3085.	3319.	3495.	3612.	3658.	3658.	
8	10.140	1622.	2026.	2426.	2805.	3078.	3301.	3470.	3583.	3631.	3632.	
9	11.492	1674.	2053.	2424.	2774.	3051.	3260.	3420.	3529.	3580.	3582.	
10	12.844	1712.	2064.	2405.	2726.	3000.	3204.	3354.	3461.	3516.	3520.	

Table III (Cont'd)

SIEX OUTPUT

TIME 9.55 PEAK BURN UP 2214. SIEX TEST CASE NO.1 -- ALL DEFAULT USER OPTIONS

PAGE 5

AXIAL SEGMENT NUMBER	DIST FROM BOT FUEL INCH	GENERATED FISSION GAS CC AT STP	- - VOLUME COLUMNAR ZONE	OF FISSION EQUIAXED ZONE	GAS RELEASED (CC) - - UNREST. ZONE	TOTAL	RETAINED FISSION GAS CC/GM OXIDE
1	.676	.27	.03	.01	0.00	.04	.033
2	2.028	.30	.04	.01	0.00	.05	.035
3	3.380	.32	.05	.01	0.00	.06	.037
4	4.732	.33	.06	.01	0.00	.07	.038
5	6.084	.33	.06	.01	0.00	.07	.038
6	7.436	.33	.06	.01	0.00	.07	.037
7	8.788	.32	.05	.01	0.00	.06	.036
8	10.140	.30	.05	.01	0.00	.06	.034
9	11.492	.28	.04	.01	0.00	.05	.032
10	12.844	.25	.03	.01	0.00	.04	.031

PERCENT FISSION GAS RELEASED 18.77
 VOLUME OF RELEASED FISSION GAS .57 (CC AT STP)
 VOLUME OF SORBED GAS 1.40 (CC AT STP)
 VOLUME OF WATER VAPOR 1.96 (CC AT STP)
 EFFECTIVE PLENUM VOLUME 5.71 (CC AT 20 DEG C)
 VOLUME OF FILL GAS 5.32 (CC AT STP)
 PLENUM PRESSURE 50. (PSIG)
 EXTERNAL PRESSURE 35. (PSIG)
 MOLES OF HELIUM 2.11E-04
 MOLES OF ZENON 4.97E-05
 MOLES OF KRYPTON 2.46E-06
 MOLES OF NITROGEN 6.26E-06
 MOLES OF ARGON 6.26E-07

Table III (Cont'd)

SIEX OUTPUT

TIME 9.55 PEAK BURN UP 2214. SIEX TEST CASE NO.1 -- ALL DEFAULT USER OPTIONS

PAGE 6

AXIAL SEMENT NUMBER	FLUENCE NEUT/CM**2	CLADDING SWELLING, % PERCENT	CLAD OUTER RADIUS, HOT INCH	FUEL OUTER RADIUS, HOT INCH	CLAD INNER RADIUS, HOT INCH	FUEL-CLAD HOT GAP INCH	FUEL-CLAD COLD GAP INCH
1	1.351E+21	4.437E-04	.1158	.0995	.1004	.00089	.00171
2	1.468E+21	4.893E-04	.1158	.0997	.1004	.00069	.00152
3	1.569E+21	4.925E-04	.1158	.0999	.1004	.00053	.00136
4	1.630E+21	4.322E-04	.1159	.1000	.1005	.00043	.00126
5	1.650E+21	3.281E-04	.1159	.1001	.1005	.00041	.00123
6	1.628E+21	2.203E-04	.1159	.1000	.1005	.00045	.00126
7	1.564E+21	1.373E-04	.1159	.1000	.1005	.00056	.00137
8	1.475E+21	8.389E-05	.1160	.0998	.1005	.00071	.00151
9	1.364E+21	5.151E-05	.1160	.0996	.1005	.00091	.00169
10	1.257E+21	3.266E-05	.1160	.0994	.1006	.00112	.00185
11	1.239E+21	2.769E-05	.1160				

Table III (Cont'd)

SIEX OUTPUT

TIME 9.55 PEAK BURN UP 2214. SIEX TEST CASE NO.1 -- ALL DEFAULT USER OPTIONS PAGE 7

SEG	--- INSIDE STRESS ---			--- OUTSIDE STRESS ---		
	TANGENTIAL	AXIAL	EFFECTIVE	TANGENTIAL	AXIAL	EFFECTIVE
1	-14557.	-14618.	14537.	13288.	13242.	13300.
2	-15673.	-15734.	15653.	14292.	14246.	14304.
3	-16586.	-16647.	16566.	15113.	15067.	15125.
4	-17067.	-17128.	17048.	15546.	15500.	15558.
5	-17116.	-17177.	17097.	15590.	15544.	15602.
6	-16749.	-16810.	16730.	15261.	15215.	15273.
7	-15963.	-16024.	15943.	14554.	14508.	14566.
8	-14947.	-15008.	14928.	13641.	13595.	13653.
9	-13740.	-13801.	13721.	12554.	12509.	12567.
10	-12587.	-12648.	12567.	11515.	11469.	11527.
11	-12365.	-12426.	12346.	11316.	11270.	11328.

IV. MATHEMATICAL MODELS

FSINTR: FUEL TEMPERATURE CALCULATIONS

The FSINTR subroutine computes the steady state radial temperature distribution of the fuel material of a cylindrical fuel rod. The method uses the integral of the thermal conductivity. This allows for temperature-dependent thermal conductivity and densification (conductivity and fuel geometry changes). The theoretical basis has been documented in Reference 2, and is reviewed here for completeness. Also presented is the currently used fuel thermal conductivity equation and the method used to incorporate it into the code.

The temperature, T , within the fuel is assumed to be described by the steady state heat conduction equation

$$\nabla \cdot (k\nabla T) = -q$$

k = conductivity (temperature dependent)

q = the volumetric heat generation rate.

In cylindrical coordinates for axial symmetry and long cylinders (no axial heat transfer), this becomes

$$\left[\frac{1}{r} \frac{\partial}{\partial r} (rk \frac{\partial T}{\partial r}) \right] = -q(r) \quad (1)$$

Let r_0 and r_m be defined as in Figure 5, multiply (1) by r and integrate from r_m to some radius r . We then have

$$rk \frac{\partial T}{\partial r} = - \int_{r_m}^r \zeta q(\zeta) d\zeta \quad (2)$$

Dividing (2) by r and integrating from r to r_0 we have

$$\int_T^{T_0} k dt = - \int_r^{r_0} \frac{1}{\xi} \int_{\xi_m}^{\xi} \zeta q(\zeta) d\zeta d\xi \quad (3)$$

If we can assume $q(\zeta)$ is a constant within an annular ring, we can perform the integration in (3) and obtain the following:

FIGURE 5
FUEL AND CLADDING HEAT TRANSFER GEOMETRY

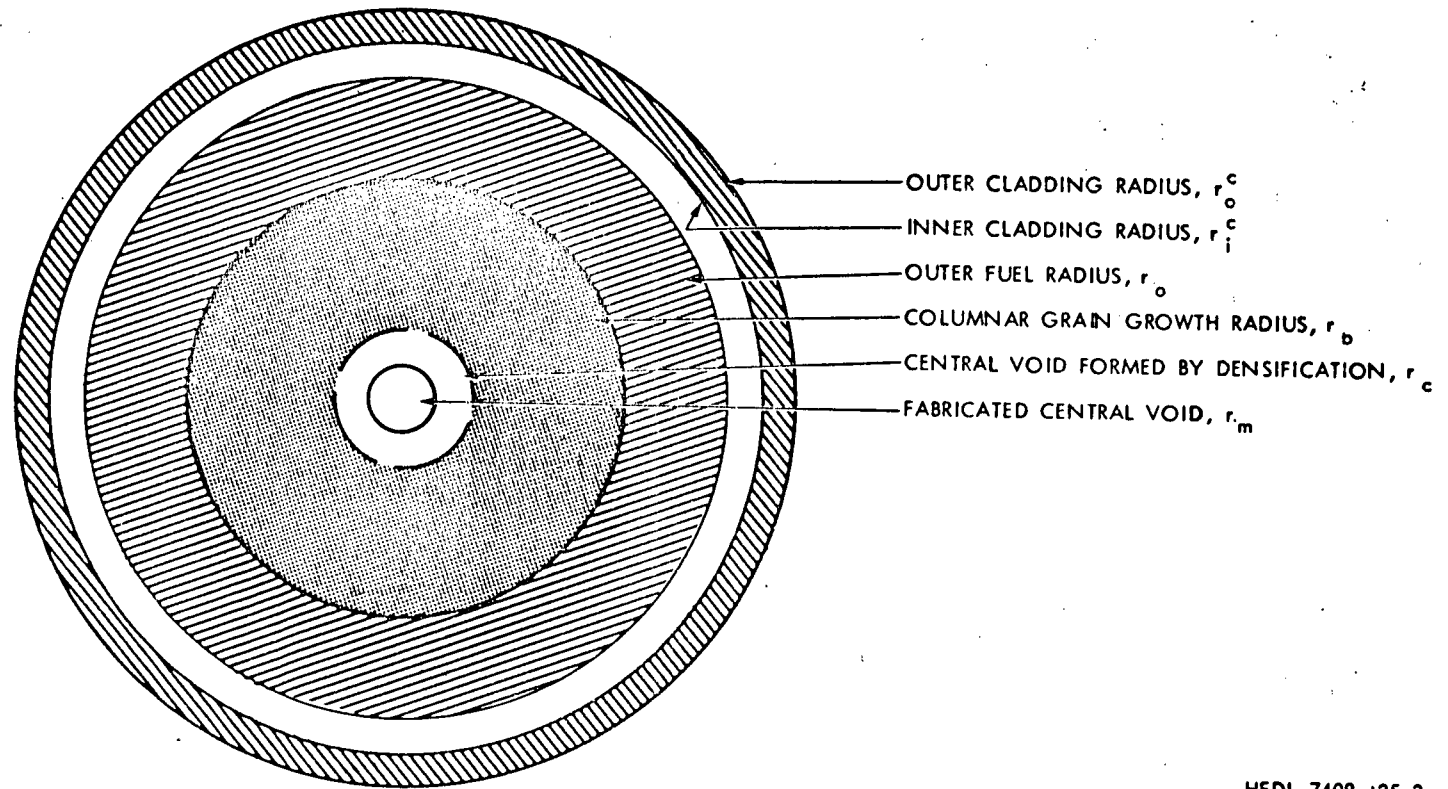

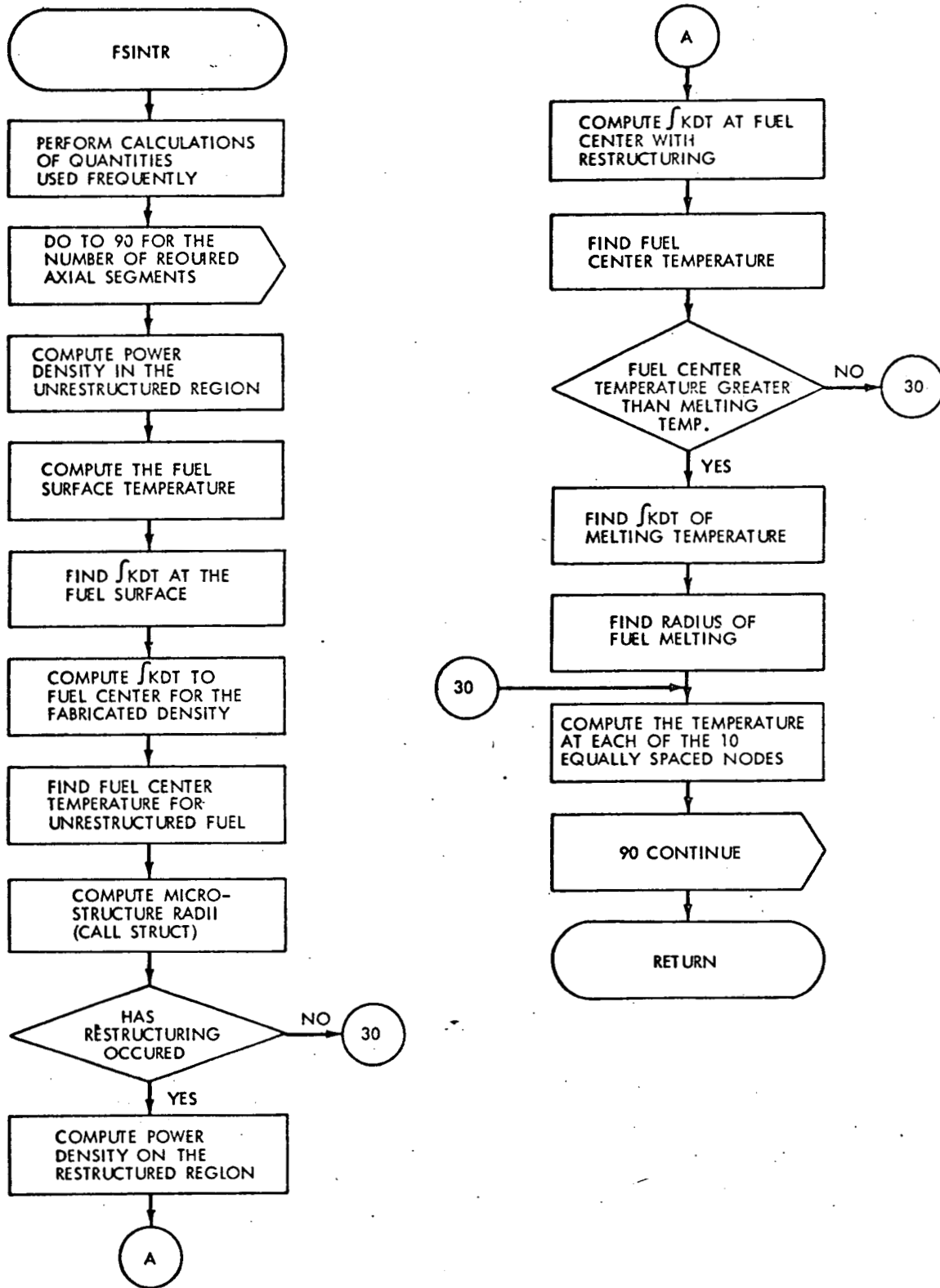

Figure 6. FSINTR Flow Chart

Routines Associated with the Fuel Thermal Conductivity.

No flow charts are provided for these routines because of their simplicity.

S: Evaluation of the integral of the fuel thermal conductivity.

The thermal conductivity equation is of the form:

$$K^f = K^D \left[\frac{1}{K_1^f + K_2^f \times T} + K_3^f \times T^3 \right]$$

where K^f = thermal conductivity, w/cm-°K

$$K^D = K_p^f \times P \times (1. + (1. + 10. \times (1-P)) \times (1-P))^{-1}$$

T = temperature, °K

P = fraction of theoretical density

$K_p^f, K_1^f, K_2^f, K_3^f$ are coefficients in the equation.

The SIEX program requires that this be integrated with respect to T, resulting in:

$$\int K^f dT = K^D \times \left[\ln \left(\frac{K_1^f + K_2^f \times T}{K_2^f} \right) + .25 K_3^f \times T^4 \right] \quad (6)$$

This function, S, is programmed to evaluate Equation (6). A call to SINPUT calculates the density dependent coefficients. These then are used to compute a table of values for $\int k dt$ at every 200°C for use in the table interpolation routine to be described in the next section.

T: Routine to find a value of temperature given a value for $\int k dt$.

The routine uses simple linear interpolation between values of T and $\int k dt$ at intervals of 200°C. A routine to numerically find the inverse of Equation (6) could be provided if the increased accuracy is desired.

RFIND: Routine to find a radius corresponding to a given temperature.

In order to find restructuring and melt radii, it is necessary to find the inverse of Equation (5), i.e., given T, S_0 , q, find a value of r. The numerical solution is simply the Newton-Raphson method (reference 3). To put Equation (5) in the proper form, we evaluate $\int k dt$ at the desired temperature to obtain the quantity S_T . We then have

$$4(S_T - S_0)/q = r_0^2 - r^2 - 2r_m^2 \ln(r_0/r). \quad (7)$$

Define $\tau = r_0^2 - 4(S_T - S_0)/q$,

then (7) reduces to

$$0 = r^2 + 2 r_m^2 \ln(r_0/r) - \tau \quad (8)$$

which can be solved for r numerically.

CSINTR: Computes coolant temperature and cladding temperature distributions.

The increase in coolant temperature along the pin is computed by adding the heat deposited in the coolant at each axial node. The amount of heat passing into the coolant from each axial segment is:

$$q_l \times h$$

where $q_l = q \pi (r_0^2 - r_m^2)$ the linear heat rate at the pin surface evaluated at the center of each element

h = the element length,

thus causing a change in temperature given by:

$$\Delta T_c = q_l h / (C_p \times M_F) \quad (9)$$

where C_p = the heat capacity

M_F = the coolant mass flow rate.

Each of these temperature increases are accumulated over the length of the fuel pin. The SIEX code considers the mass flow rate* as uniform around and along the pin.

The temperature increase across the thin film of coolant immediately adjacent to the cladding is simply given by applying the definition of a heat transfer coefficient, i.e.,

$$\Delta T = \frac{q_l}{AH}$$

where H = the film coefficient

A = the surface area per unit length;

or, to compute the outer cladding temperature

$$T_0^c = T_c + \frac{q_l}{2\pi r_0^c H} \quad (10)$$

*Mass flow rates for EBR-II subassemblies are obtained from COBRA analyses.

where T_0^C = the outer cladding temperature

T_c = the coolant temperature

r_0^C = the outer cladding radius.

The cladding temperature distribution is calculated using Equation (1) with q set equal to zero; viz.,

$$\frac{1}{r} \frac{\partial}{\partial r} (rk \frac{\partial T}{\partial r}) = 0$$

or

$$\frac{\partial}{\partial r} (r\bar{Q}) = 0$$

where $\bar{Q} = -k \frac{\partial T}{\partial r}$ is the heat flux vector.

Integrating from r_0^C to r , we have

$$-k \frac{\partial T}{\partial r} = \frac{r_0^C \bar{Q}_0}{r}$$

Integrating again, we obtain

$$T = T_0^C + \frac{r_0^C \bar{Q}_0}{k} \ln (r/r_0^C) \quad (11)$$

SIEX uses this equation to compute the inner cladding surface temperature when:

T_0^C , k , r_0^C , and q_l (the linear heat rate) are given. Now $\bar{Q}_0 = q_l / 2\pi r_0^C$, so that the SIEX application of (11) is

$$T_i^C = T_0^C + \frac{q_l}{2\pi k} \ln (r_i^C / r_0^C)$$

Figure 7 shows the CSINTR logical flow.

CDELD: Computation of Dimensional Changes of the Cladding Material.

The thermal expansion of the cladding is computed from an input linear function of temperature; that is, the change in the radius of the cladding is given by:

$$\Delta L/L = (\alpha_0^C + \alpha_T^C) (T - T_R)$$

FIGURE 7
CSINTR FLOW CHART

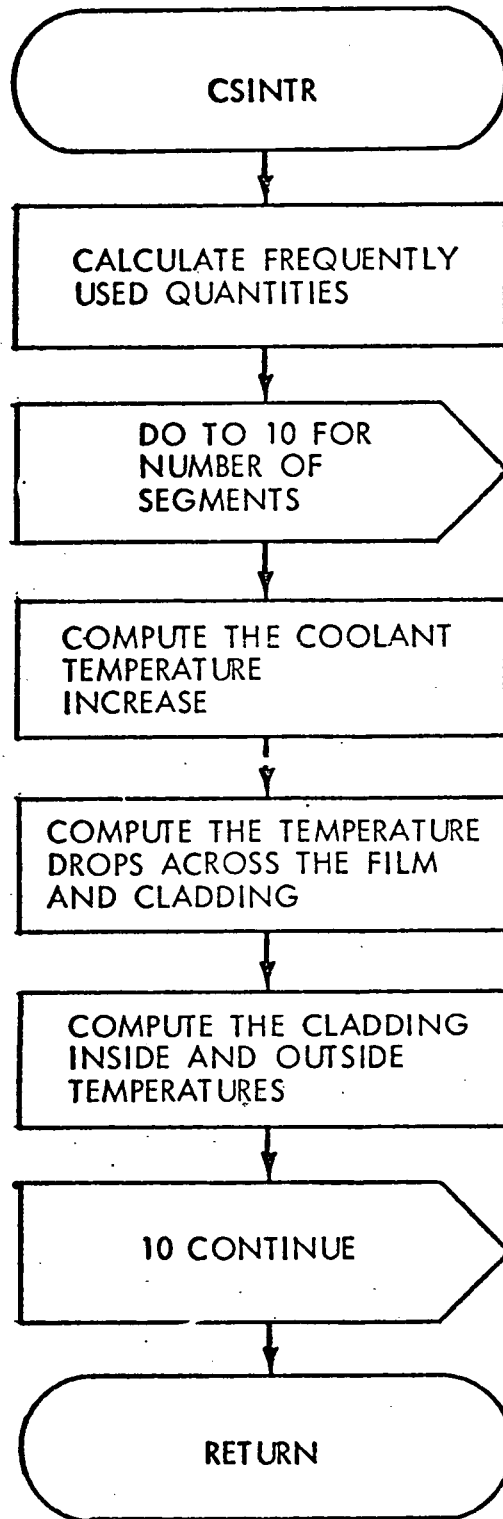

where α_0^C and α_T^C are input quantities, T_R is room temperature, T is the average cladding temperature, and $\Delta L/L$ is the fraction of length change.

Three functions are currently programmed into the code to compute the cladding swelling, depending on cladding material type. For annealed stainless steel Type 304 (Reference 4),

$$\% \Delta V / V_C = A(\phi t)^m + B$$

where $A = 2.65 \times 10^{-8} \alpha^3 - 1.54 \times 10^{-5} \alpha^2 + 2.24 \times 10^{-3}$

$$B = \frac{0.2[1 - \exp(-1.12 \phi t)]}{[1. + \exp(0.1 \times (T - 480.))]}$$

$$m = 0.872 + 2.98 \times 10^{-3} T$$

$$\alpha = T - 348$$

T = Temperature, °C

ϕt = Fluence, neutrons/cm² $\times 10^{-22}$ ($E > 0.1$ MeV)

$\% \Delta V / V_C$ = % swelling.

For annealed stainless steel Type 316 (Reference 4),

$$\% \Delta V / V_C = f(T) \{ \phi t \}^{N(T)}$$

where $f(T) = \{ \exp(C) / (1. + \exp(C)) \} \left\{ \frac{0.02}{(1. + \exp(A))} + \frac{0.06}{(1. + \exp(B))} \right\}$

$$N(T) = \{ 2. + 3. \exp(D) \} / \{ 1. + \exp(D) \}$$

$$A = 0.05 (T - 600)$$

$$B = 0.06 (T - 460)$$

$$C = 0.09 (T - 340)$$

$$D = 0.05 (T - 475)$$

$\% \Delta V / V_C$ = % swelling

T = Temperature, °K

ϕt = Fluence, neutrons/cm² $\times 10^{-22}$ ($E > 0.1$ MeV)

And for 20% cold-worked stainless steel Type 316

$$\% \Delta V / V_c = f(T) \{ \phi t \} N(T)$$

$$\text{where } f(T) = \left\{ \frac{\exp(C)}{1. + \exp(C)} \right\} \left\{ \frac{.0022}{(1. + \exp(A))} + \frac{.006}{(1. + \exp(B))} \right\}$$

$$N(T) = \left\{ \frac{2. + 3. \exp(D)}{1. + \exp(D)} \right\}$$

$$A = 0.05 (T - 600)$$

$$B = 0.06 (T - 460)$$

$$C = 0.09 (T - 340)$$

$$D = 0.05 (T - 475)$$

$$\% \Delta V / V_c = \% \text{ swelling}$$

$$T = \text{Temperature, } ^\circ\text{K}$$

$$\phi t = \text{Fluence, neutrons/cm}^2 \times 10^{-22} \text{ (E > 0.1 MeV).}$$

The cladding radius is then computed by

$$r'_c = r_o^c \times (1. + \Delta L/L) \times (1. + \Delta V/3V)$$

where r_o^c is the fabricated dimension.

FDELD: Computation of Fuel Dimensional Changes

The fuel thermal expansion is computed by finding the volumetric average radial displacement. At each node, the displacement is computed using the coefficient of thermal expansion given by:

$$\alpha^f = \alpha_o^f + \alpha_T^f \times T$$

where α^f = Coefficient of thermal expansion, cm/cm- $^\circ\text{C}$

$$T = \text{Temperature, } ^\circ\text{C.}$$

The volumetric average thermal expansion is then computed by

$$\begin{aligned} \overline{\Delta D/D} &= \frac{\int_0^{r_o} \Delta D/D \cdot r dr}{\int_0^{r_o} r dr} \\ &= \frac{\int_{r_c}^{r_o} \alpha^f T \cdot r dr}{\int_{r_c}^{r_o} r dr} = \frac{\int_{r_c}^{r_o} \alpha^f T \cdot r dr}{1/2(r_o^2 - r_c^2)} \end{aligned} \quad (13)$$

The integration in (13) is performed numerically by using the trapezoidal rule.

The fuel swelling, ΔD_S , is supplied by the empirical routine FSWEL which will be discussed in Section III. The fuel radius at operating conditions is then computed by using:

$$r'_f = (r_o + \Delta D_S) \times (1. + \overline{\Delta D/D}) \quad (14)$$

where r'_f is the "hot" fuel radius.

PPRES: Computation of Plenum Pressure.

The source of gases which can contribute to a rise in plenum pressure are assumed to be:

- fill gas brought to operating conditions, V_f^*
- sorbed gases in the fuel, V_s
- water vapor in the fuel, V_w
- released fission product gases, V_r

The pressure is then computed by:

$$P_p = (V_f + V_s + V_w + V_r) \times T_c \times P_{atm} / (273 \times V). \quad (15)$$

where T_c = The coolant outlet temperature, °K

P_{atm} = One atmosphere of pressure

V = The effective plenum volume.

The effective plenum volume, sorbed gas, and water vapor are input quantities. The volume of released gaseous fission products is supplied from the FISGAS routine which contains a correlated fission gas release model.

* This volume is computed from the "Effective Plenum Length" and taken to be at 1 atm at 20°C.

V. CORRELATED MODELS

This section describes those portions of SIEX which are correlations to data obtained from Hanford Engineering Development Laboratory (HEDL) fuel pins irradiated in EBR-II. The power-burnup range is shown in Figure 8. The data set contains a wide range of fuel densities, three types of cladding material (annealed 304 SS, annealed 316 SS, and 20% CW 316 SS), and two fuel fabrication methods (pressed and preslugged).

The measurements of concern are:

- . Postirradiation fuel-cladding gap
- . Fuel columnar grain growth radius
- . Fuel equiaxed grain growth radius
- . Fission gas present in the plenum region
- . Axial location of incipient melting (P-19), See reference 5

Figure 9 shows the interaction of these measured quantities and the models to be developed. Each of the correlations will be discussed individually and in some detail, but physically the interaction of correlations and the sequence of the correlations are important. Data are transferred to the right and upward to complete a correlation. Once a model has been developed and correlated, it is used in subsequent model development replacing the data from which it was derived. To ensure a consistent data set, only data from fuel pins for which ¹⁴⁸Nd burnup analysis was available were used. The time average power for each pin was then calculated* in a consistent manner and adjusted to the energy assumed deposited in the fuel element.**

* For EBR-II pins the following constants were used:

	Average Fission Cross-Section (Reference 35)	Nd-148 Fission Yields (Reference 36)	Total Energy Per Fission Deposited in the Reactor (Reference 37)
U-235	1.36 barns	1.75%	203 MeV
U-238	0.0855	1.93	201
Pu-239	1.64	1.71	211

**Based on Reference 33, it was assumed the energy deposited in an element was 9.2 MeV/fission less than the total energy deposited in the reactor core, blanket, and reflector.

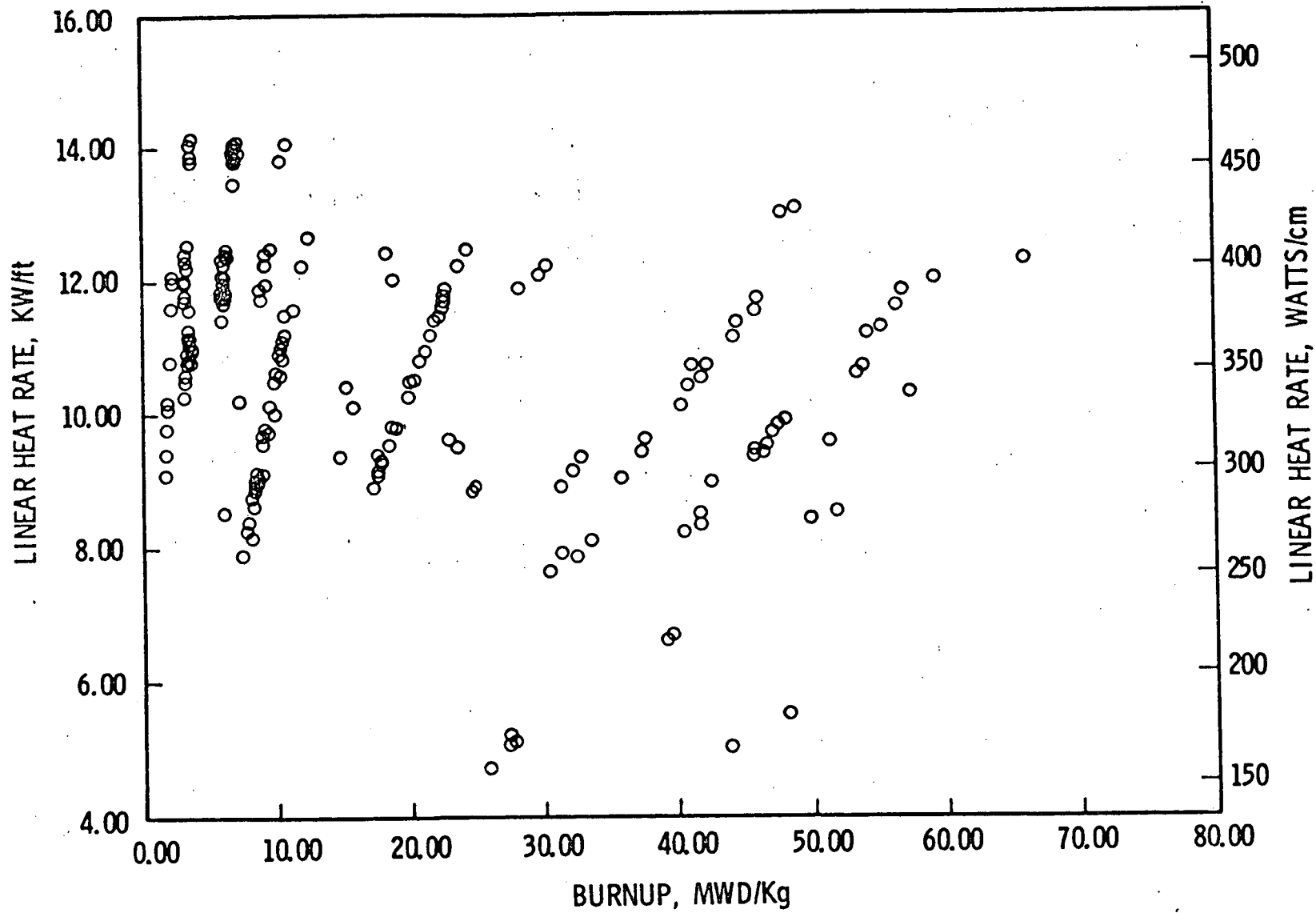
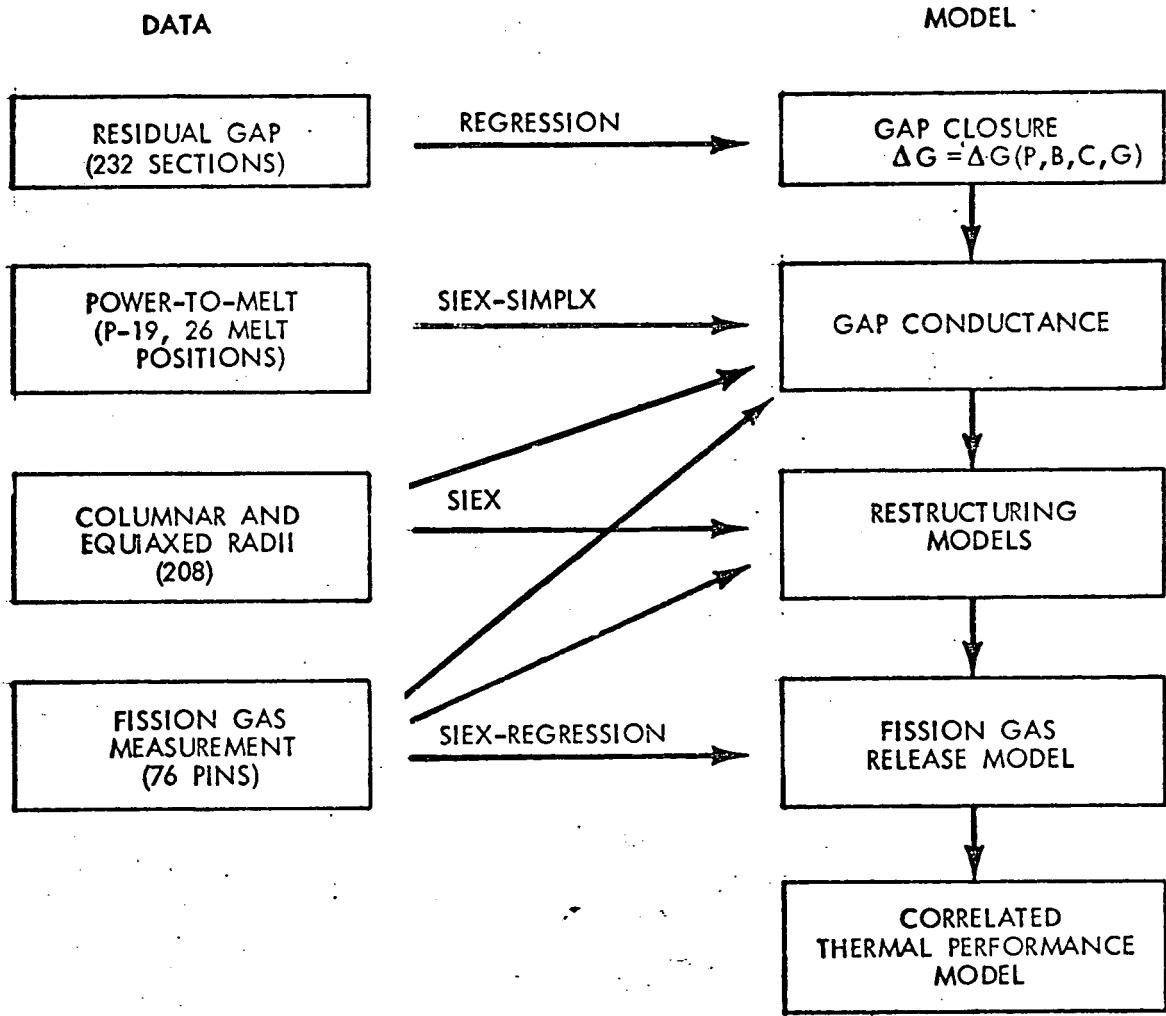

FIGURE 8. DATA FIELD FOR POSTIRRADIATION FUEL-CLADDING GAP CORRELATION



HEDL 7408-83.1

FIGURE 9. DATA INTERACTION AND USAGE FOR SIEX CORRELATIONS

FSWEL: Residual Gap Correlation

It is necessary to predict the fuel-cladding hot gap in order to accurately predict the fuel-cladding heat transfer coefficient. It is assumed that the postirradiation fuel-cladding gap (as measured from postirradiation metallography) along with the differential thermal expansion can be used for calculating the hot fuel-cladding gap during the irradiation of a mixed-oxide fuel pin. A similar analysis is presented in Reference 6.

Detailed analysis of the fuel deformation mechanisms can be accomplished with the LIFE (Reference 7) and PECT codes. In these cases, running times are long because a small time step is required to solve the rate equations. In keeping with the philosophy of SIEX being a faster running code, a correlation to postirradiation gap data is used.

The data for postirradiation fuel-cladding gap were measured from 75X photomosaics of transverse fuel pin cross-sections, in the as-polished condition. Measurements were taken at four equally spaced angles, as shown in Figure 10. These four measurements were then averaged to provide an effective postirradiation diametral fuel-cladding gap.

The correlation was developed by regression analysis of 232 averaged residual gap measurements using the computer code REEP. (Reference 8). The model is assumed to be dependent on local linear heat rate, local burnup, fabricated gap, and the number of reactor cycles. The correlation is of the form

$$G' = G \left\{ 1 - [\alpha(1 - \exp(-G_3 \times C)) + G_4(1 - \exp(-G_5 \times q_l \times B)) + (G_6 - \alpha)(1 - \exp(-G_7 \times B))] \right\} \quad (16)$$

Where

- G' = The "cold" postirradiation diametral gap, cm
- G = Fabricated fuel-cladding gap, cm
- α = $G_1 \times q_l \times (q_l - G_2)$
- q_l = Local linear heat rate, kW/ft
- B = Local burnup, MWd/kg
- C = Number of full power reactor cycles
- G_1 through G_7 are fitting coefficients

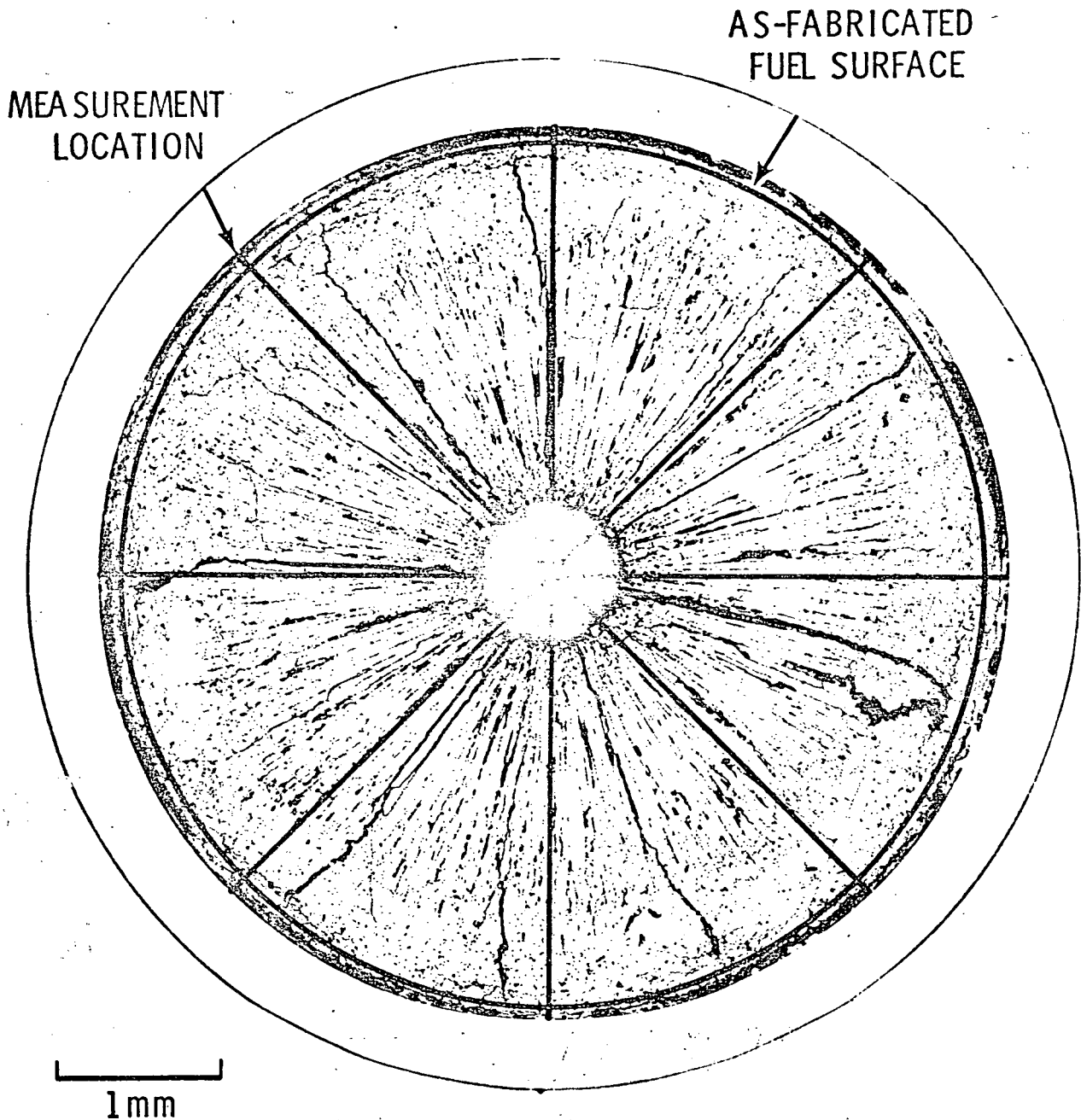

LINEAR HEAT RATING	≈	12.2 kw/ft
BURNUP	≈	57 MWd/kg
FABRICATED GAP	=	5.7 mils
POST IRRADIATION GAP	=	4.2 mils

FIGURE 10. POST IRRADIATION GAP MEASUREMENT

The quality of fit to data is shown in Figure 11, along with the approximate variance of the data (root mean squared deviation). Other parameters which might influence the residual gap observed in a fuel pin were investigated, namely cladding material, fuel geometry, pellet fabrication method, and pin diameter. In each of the above cases, no significant contribution of the variable to residual gap could be found.

Figure 12 demonstrates the model behavior under certain hypothetical conditions. Three power levels for a 6 mil diametral gap pin were used to evaluate equation (16) as a function of burnup and the number of cycles. The cyclic behavior and indeed the majority of the gap closure, occurs during the early operating life of the fuel element. Although the imposed cyclic behavior of one cycle every MWd/kg is arbitrary, it is typical of conditions experienced by the fuel elements in the data set.

HGAP: Fuel-Cladding Gap Conductance

The SIEX gap conductance is a simplification of the Ross-Stoute gap conductance model similar to those models presented in References 9 and 10. Certain procedures of the model have been simplified for efficiency and because there is a lack of precise input values for some of the constants. The gap conductance model has three identified parameters which have been adjusted by calibrating to postirradiation observation of fuel pin performance, namely observations of melt locations in the P-19 experiment (Reference 5).

The model considers three components contributing to the heat transfer across the fuel-to-cladding gap. When the fuel and cladding are not in contact, the mechanisms are radiant heat transfer and heat conduction through the gas in the fuel-cladding gap. If the fuel and cladding come into contact, the third component, solid-solid conduction at points along the fuel-cladding interface is used. In this case, there is still heat transfer through "pockets" of gas trapped between the points of contact. Schematic representations of the geometry in these two cases are shown in Figure 13.

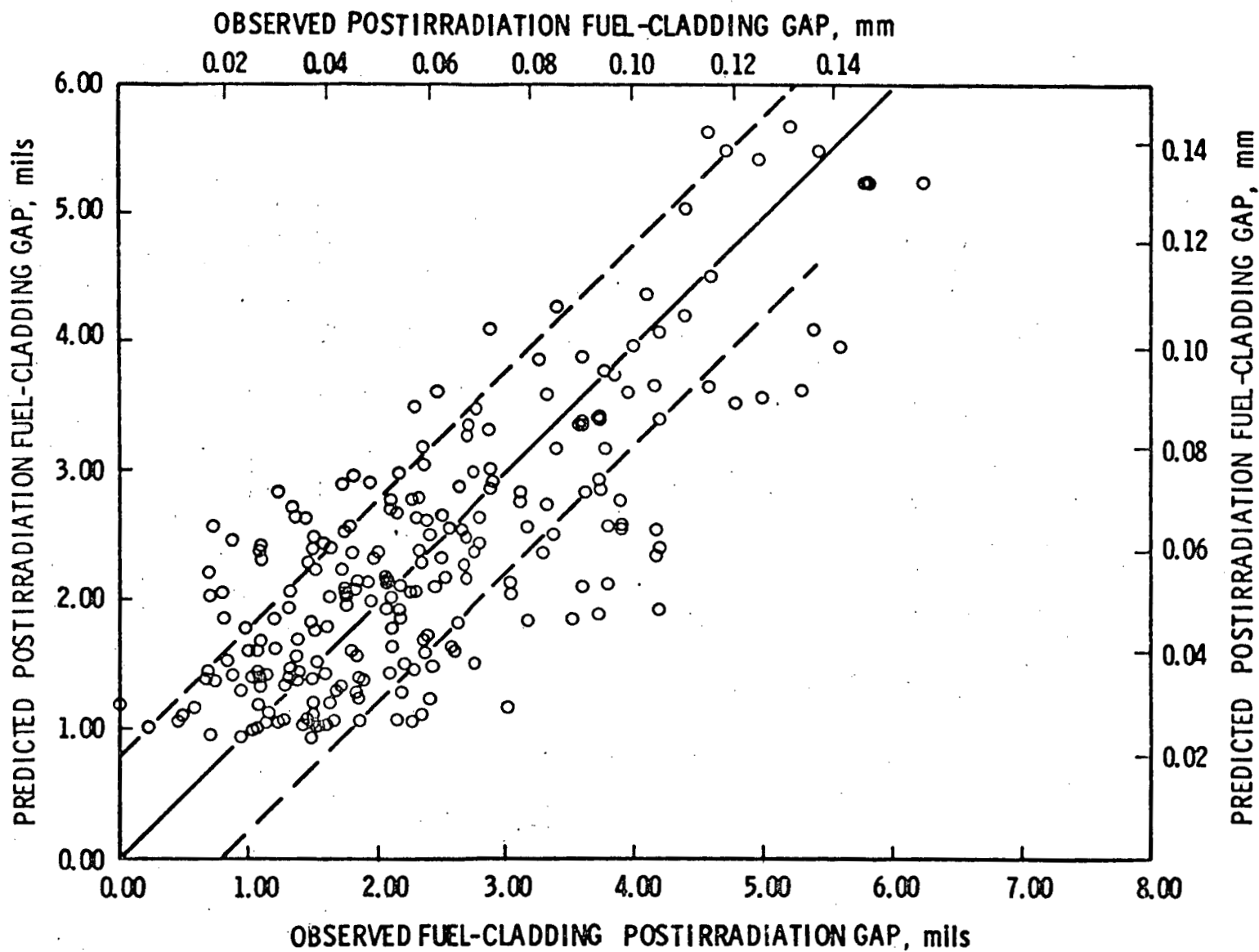

FIGURE 11. POSTIRRADIATION DIAMETRAL FUEL-CLADDING GAP CORRELATION

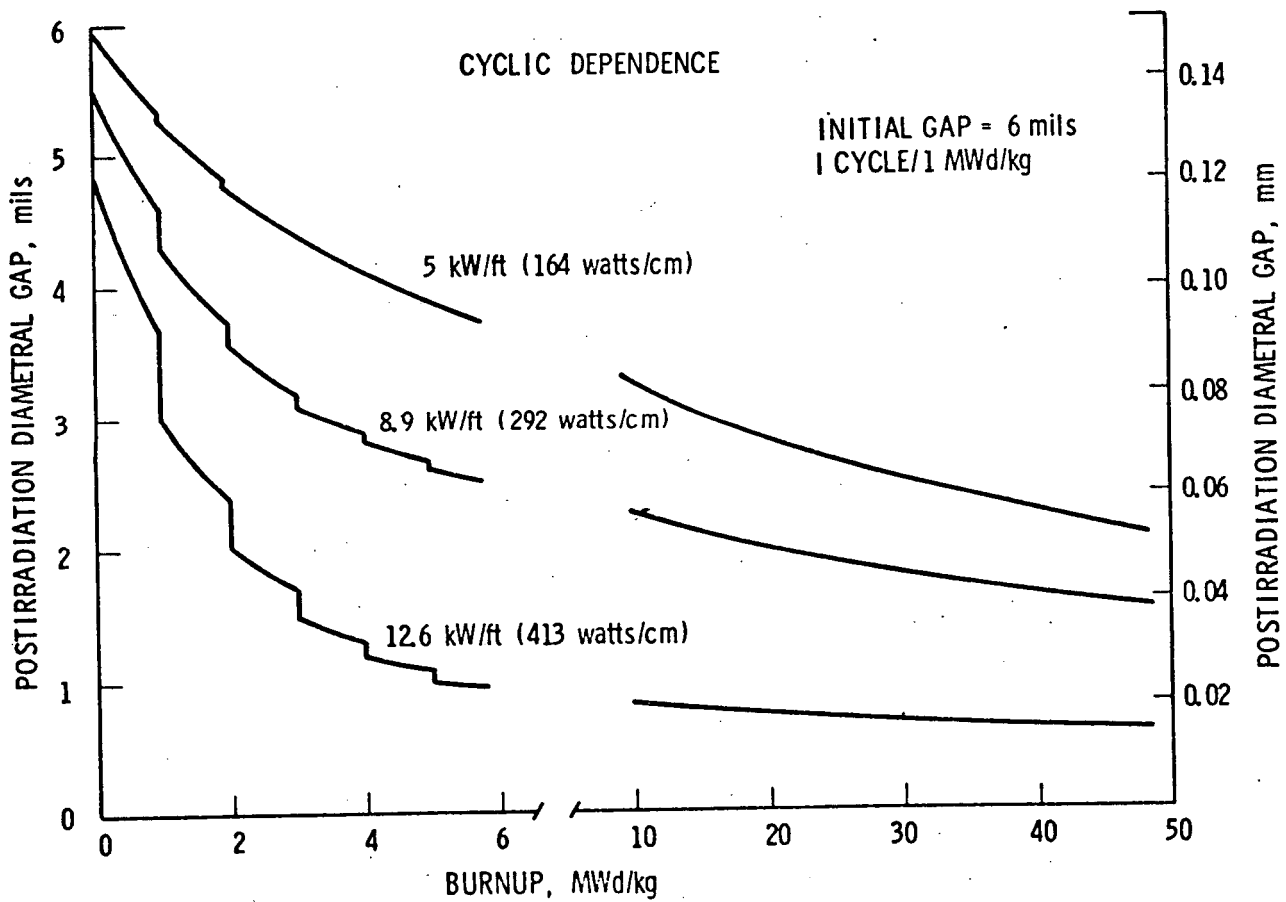
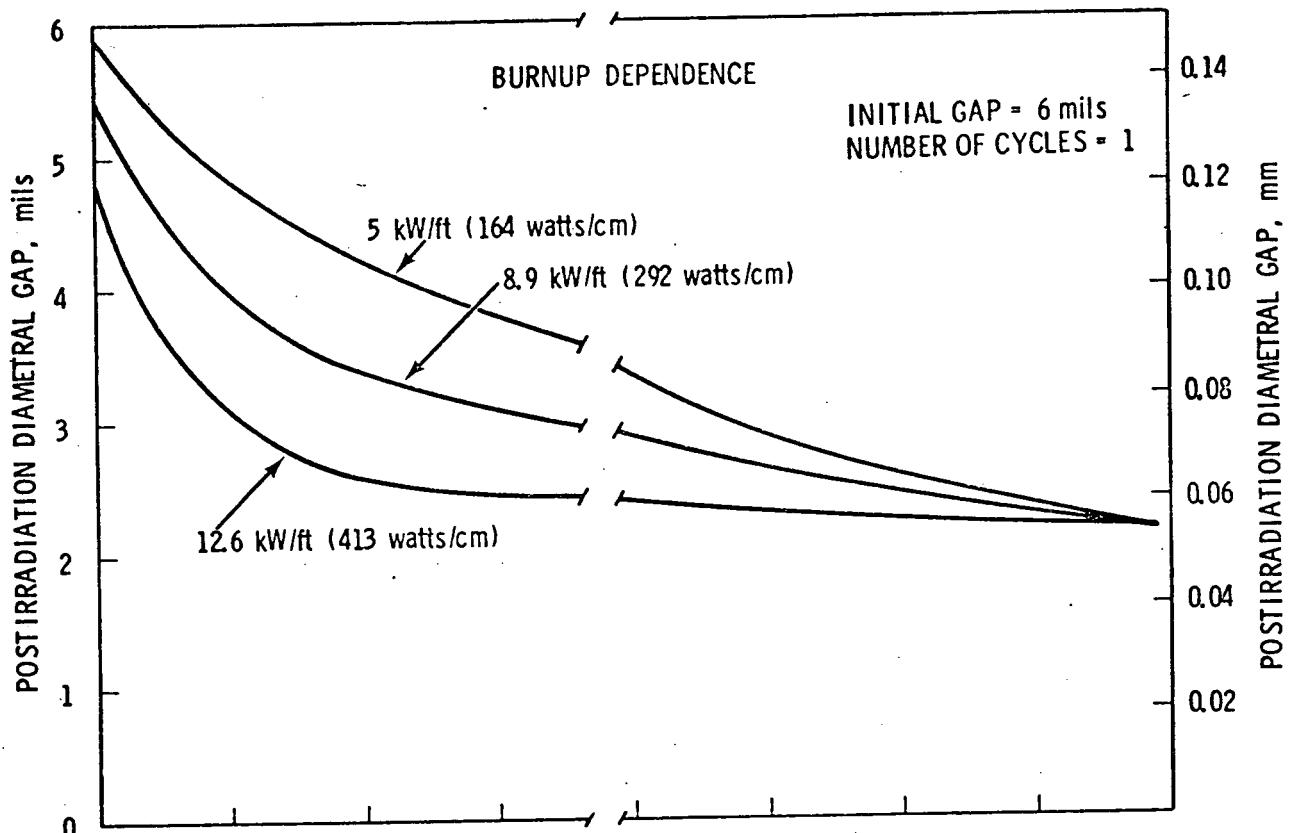
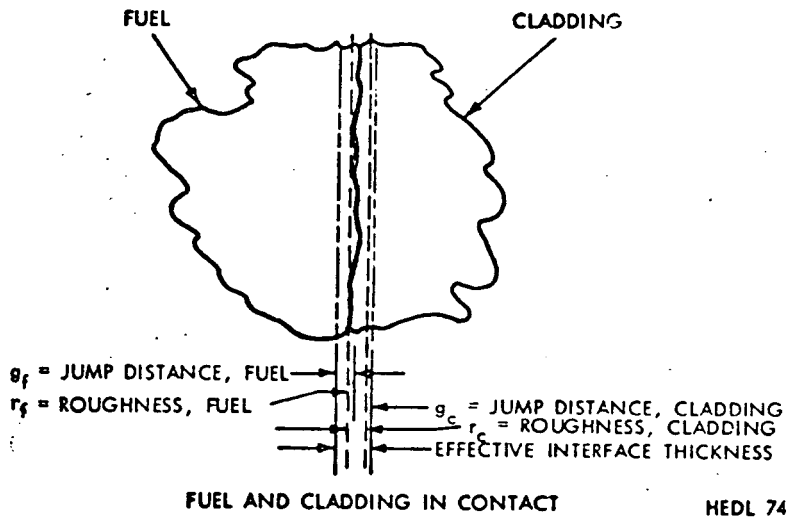
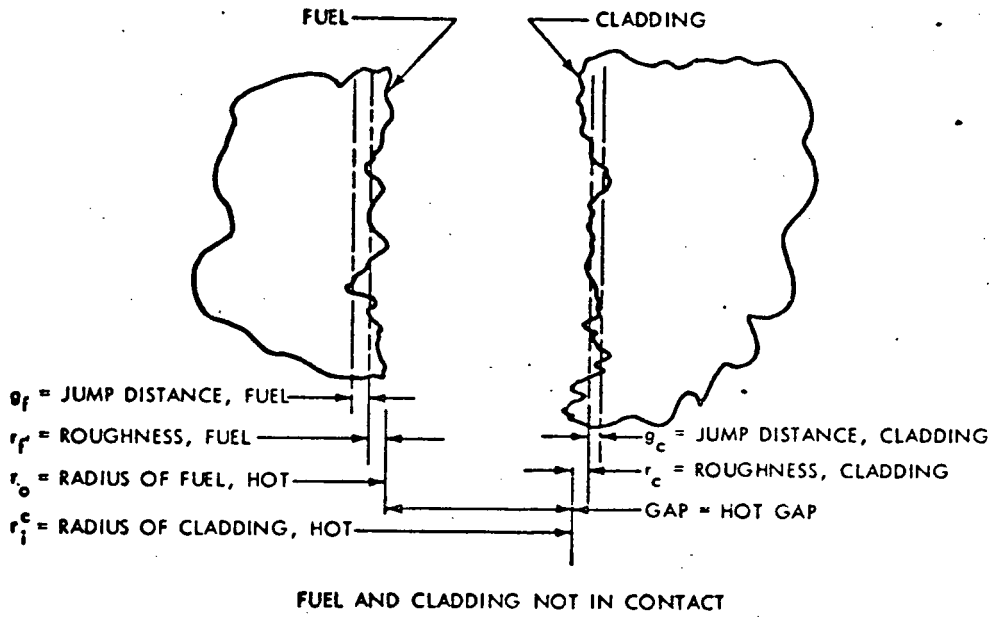

FIGURE 12. FUEL-CLADDING POSTIRRADIATION GAP MODEL



HEDL 7408-125.1

FIGURE 13. FUEL-CLADDING HEAT TRANSFER SCHEMATIC

Radiant Heat Transfer

The radiant heat transfer relationship for two concentric cylinders can be written as: (Reference 11)

$$q_l/A_f = \sigma \left[\frac{1}{\epsilon_f} + \frac{A_f/A_c}{\left(\frac{1}{\epsilon_c} - 1 \right)} \right]^{-1} [T_f^4 - (T_i^c)^4] \quad (17)$$

where T_f and T_i^c are the fuel and cladding temperatures ($^{\circ}\text{K}$), A_f and A_c the heat transfer areas per unit length, ϵ_f and ϵ_c their respective emissivities, and σ the Stefan Boltzman constant. If the gap coefficient is defined as:

$$H_r = \frac{q_l/A_f}{T_f - T_i^c}$$

and is substituted into equation (17), the following expression is obtained:

$$H_r = \sigma \left[\frac{1}{\epsilon_f} + \frac{A_f/A_c}{\left(\frac{1}{\epsilon_c} - 1 \right)} \right]^{-1} [T_f^2 + (T_i^c)^2] [T_f + T_i^c]. \quad (18)$$

Heat Transfer Across a Gas Filled Effective Gap

The gas gap conductance of Ross and Stoute (Reference 12) is given by:

$$H_{\text{gas}} = \frac{k_m}{C(r_f + r_c) + (g_f + g_c) + \text{GAP}} \quad (19)$$

where k_m = the conductivity of the gas mixture in the fuel-cladding gap
 GAP = fuel-cladding hot gap

g_f, g_c = the temperature jump distances to be described below
 $C(r_f + r_c)$ = a term dealing with the fuel and cladding surface roughness
 C = a fitting parameter.

The temperature jump distances, g_f and g_c , represent temperature increases at the fuel and cladding surfaces as a result of incomplete energy interchanges between the surfaces and the gas (Reference 13) and can be written as:

$$g' = \frac{2 - a}{a} (2\pi R_m T)^{1/2} \frac{k_m}{(\gamma + 1) C_v P_p}$$

where a = accomodation coefficient reflecting the extent of energy transfer

R_m = the gas constant for the mixture

P_p = the gas pressure of the gap

γ = ratio of C_p/C_v

T = temperature at the fuel surface for g_f or at the cladding surface for g_c

C_v = specific heat at constant volume for the mixture.

g' is to be evaluated at both the fuel and cladding surfaces to produce $g_f + g_c$.

This expression was simplified by combining terms and making assumptions about the behavior of the variables. Factoring and combining terms, we obtain:

$$g_f + g_c = \frac{2-a}{a} \frac{\sqrt{2\pi R_m}}{(1+\gamma) C_v P_p} \left(k_m^f \sqrt{T_f} + k_m^c \sqrt{T_i^c} \right)$$

If it is assumed that the last term can be replaced by: $2\bar{k}_m \sqrt{\bar{T}}$ where

$\bar{T} = .5(T_f + T_i^c)$ and \bar{k}_m is k_m evaluated at \bar{T} , the expression reduces to:

$$g_f + g_c = 2 \frac{2-a}{a} \frac{\sqrt{2\pi R_m}}{1 + \gamma C_v P_p} \bar{k}_m \sqrt{\bar{T}}$$

We now substitute the following known values and approximations:

$$2\pi = 6.2832$$

$$(1 + \gamma) = 1.659$$

$$R_m = 8.308/\bar{W}$$

$$C_v = 2.988/\bar{W}$$

\bar{W} is the atomic weight of the mixture

The following expression is obtained

$$g = (g_f + g_c) = 1373 \left(\frac{2-a}{a} \right) \left(\frac{\bar{k}_m \sqrt{\bar{T} \bar{W}}}{P_p} \right), \text{ cm} \quad (20)$$

Solid to Solid Heat Transfer Component

Ross and Stoute (Reference 12) have suggested that the solid to solid heat transfer coefficient be written as:

$$H_s = K_s P / (A_o \times r^{1/2} H), \text{ W/cm}^2 - ^\circ\text{C}$$

where $K_s = 2K^c \times K^f / (K^c + K^f)$, the effective solid conductance, $\text{W/cm} - ^\circ\text{C}$

$$r = \left(\frac{r_c^2 + r_f^2}{2} \right)^{1/2}, \text{ the root mean squared roughness, cm}$$

P = the interfacial pressure, dynes/cm²

H = the Meyer hardness, dynes/cm²

A₀ = a constant used in fitting, cm^{1/2}

Simplification of this expression was accomplished by substituting into the expression the values for the roughness term and Brinell hardness* (Reference 14), which was assumed to be proportional to the yield strength, to obtain:

$$H_s = A \times K_s \times P/Y \quad (21)$$

where Y is the cladding yield strength and A is a parameter to be determined by data correlation and includes the yield strength at room temperature, A₀, r^{1/2}, and the Brinell hardness.

Gas Conductivity

The fuel-cladding gas gap is assumed to be filled with a mixture comprised of helium, nitrogen, argon, xenon, and krypton. Data for gas component conductivities are analysed using standard regression techniques to obtain a quadratic of the form $k_i = A_i + B_i T + C_i T^2$, where T is in °C. The coefficients thus derived are given in Appendix B. From these component conductivities a gas mixture conductivity is computed using Brokaw's law: (Reference 15)

$$k_m = .5 \left(\sum x_i k_i + \frac{1}{\sum x_i / k_i} \right)$$

where x_i is the molar fraction of the ith component.

Accommodation Coefficient

An expression relating the accommodation coefficient to the atomic weight of a gas was derived by regression techniques to the values presented in Reference 16. The expression is of the form:

$$a = A_1 \exp (-[\ln(\bar{W}) - A_2]^2 / A_3)$$

The accommodation coefficient is then based on the average molecular weight of the mixture, \bar{W} , which was discussed previously and A₁, A₂ and A₃ which are fitting coefficients.

* Because of lack of Meyer hardness data this is taken to be the Brinell hardness

Calculation of Interface Pressure

The interface pressure calculation is computed as if only elastic deformation occurs. If, as is shown in Figure 14, the fuel outer radius exceeds the cladding inner radius by Δr , it is assumed that the cladding and fuel deform elastically by this amount. For the derivation of the interface pressure the following symbols are defined:

$\sigma_r^c, \sigma_\theta^c$ = cladding radial and hoop stresses at r_{fc}

$\sigma_r^f, \sigma_\theta^f$ = fuel radial and hoop stresses at r_{fc}

$\epsilon_r^c, \epsilon_\theta^c$ = cladding radial and hoop strains at r_{fc}

$\epsilon_r^f, \epsilon_\theta^f$ = fuel radial and hoop strains at r_{fc}

E^f, E^c = fuel and cladding Young's Moduli

ν^f, ν^c = fuel and cladding Poisson's ratios

P_p = plenum pressure

P_e = external cladding pressure

P = interface pressure

r_{fc} = fuel-cladding interface radius

r_f = fuel inner radius

r_c = cladding outer radius

Δr = fuel-cladding interference.

For the radial stress relationships we have from Reference 17.

$$\sigma_r^c = \frac{E^c}{1 - (\nu^c)^2} \{ \epsilon_r^c + \nu^c \epsilon_\theta^c \} = -P \text{ at } r_{fc} \quad (1p)$$

$$\sigma_r^f = \frac{E^f}{1 - (\nu^f)^2} \{ \epsilon_r^f + \nu^f \epsilon_\theta^f \} = -P \text{ at } r_{fc} \quad (2p)$$

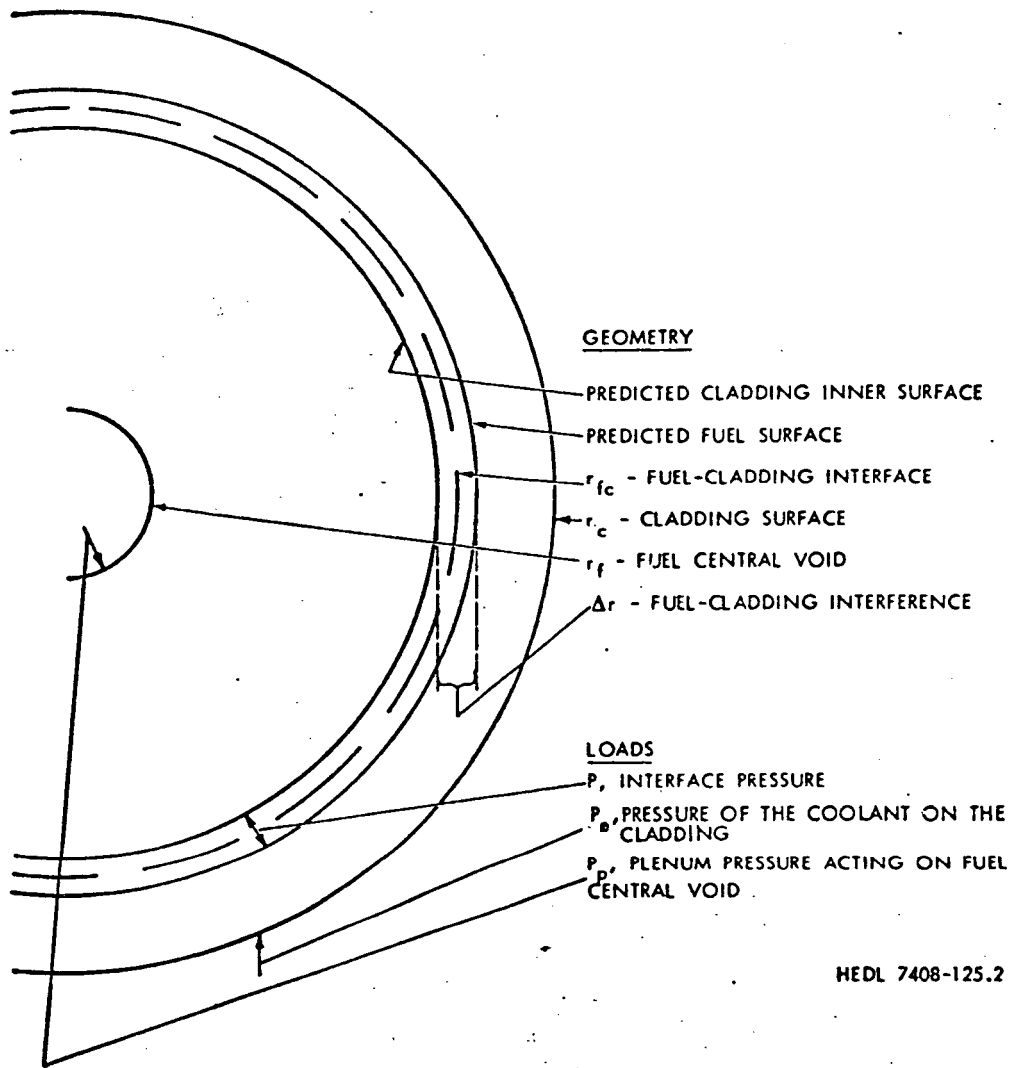

FIGURE 14. ELASTIC FUEL-CLADDING MECHANICAL INTERACTION SCHEMATIC

For the hoop stress relationships

$$\sigma_{\theta}^c = \frac{E^c}{1 - (\nu^c)^2} \{ \epsilon_{\theta}^c + \nu^c \epsilon_r^c \} = \frac{P(r_c^2 + r_{fc}^2)}{(r_c^2 - r_{fc}^2)} + \frac{2P_e r_c^2}{(r_c^2 - r_{fc}^2)} \quad (3p)$$

$$\sigma_{\theta}^f = \frac{E^f}{1 - (\nu^f)^2} \{ \epsilon_{\theta}^f + \nu^f \epsilon_r^f \} = -P \left(\frac{r_{fc}^2 + r_f^2}{r_{fc}^2 - r_f^2} \right) + \frac{2P_p r_f^2}{r_{fc}^2 - r_f^2} \quad (4p)$$

$$\epsilon_{\theta}^c - \epsilon_{\theta}^f = \Delta r / r \quad (5p)$$

Solving (3p) for ϵ_r^c

$$\epsilon_r^c = \frac{P(r_c^2 + r_{fc}^2)(1 + (\nu^c)^2)}{(r_c^2 - r_{fc}^2) \nu^c E^c} - \epsilon_{\theta}^c / \nu^c + \frac{2P_e r_c^2 (1 + (\nu^c)^2)}{(r_c^2 - r_{fc}^2) \nu^c E^c} \quad (6p)$$

Solving (4p) for ϵ_r^f

$$\epsilon_r^f = \frac{-P(1 + (\nu^f)^2)(r_{fc}^2 + r_f^2)}{\nu^f E^f (r_{fc}^2 - r_f^2)} - \epsilon_{\theta}^f / \nu^f + \frac{2P_p r_f^2 (1 + (\nu^f)^2)}{(r_{fc}^2 - r_f^2) \nu^f E^f} \quad (7p)$$

Substituting (6p) and (7p) in (1p) and (2p), we have

$$-P = \frac{P(r_c^2 + r_{fc}^2)}{\nu^c (r_c^2 - r_{fc}^2)} - \frac{E^c}{1 - (\nu^c)^2} \left(\frac{E^c}{\nu^c} - \nu^c \epsilon_{\theta}^c \right) + \frac{2P_e r_c^2}{(r_c^2 - r_{fc}^2) \nu^c}$$

or

$$-P = \frac{P(r_c^2 + r_{fc}^2)}{\nu^c (r_c^2 - r_{fc}^2)} - \frac{E^c}{\nu^c} \epsilon_{\theta}^c + \frac{2P_e r_c^2}{(r_c^2 - r_{fc}^2) \nu^c}$$

and

$$-P = \frac{-P(r_{fc}^2 + r_f^2)}{\nu^f (r_{fc}^2 - r_f^2)} - \frac{E^f}{\nu^f} \epsilon_{\theta}^f + \frac{2P_p r_f^2}{(r_{fc}^2 - r_f^2) \nu^f}$$

The preceding equations can be written as

$$\epsilon_{\theta}^c = \left\{ \nu^c + \frac{(r_c^2 + r_{fc}^2)}{(r_c^2 - r_{fc}^2)} \right\} P/E^c + \left\{ \frac{2P_e r_c^2}{(r_c^2 - r_{fc}^2)} \right\} /E^c \quad (8p)$$

and

$$\epsilon_{\theta}^f = \left\{ \nu^f - \frac{(r_{fc}^2 + r_f^2)}{(r_{fc}^2 - r_f^2)} \right\} P/E^f + \left\{ \frac{2P_p r_f^2}{(r_{fc}^2 - r_f^2)} \right\} /E^f \quad (9p)$$

Subtracting (9p) from (8p)

$$\begin{aligned} \epsilon_{\theta}^c - \epsilon_{\theta}^f &= \left[\nu^c + \frac{r_c^2 + r_{fc}^2}{r_c^2 - r_{fc}^2} + \left\{ \frac{(r_{fc}^2 + r_f^2)}{r_{fc}^2 - r_f^2} - \nu^f \right\} E^c/E^f \right] P/E^c \\ &+ \left[\frac{2P_e r_c^2}{r_c^2 - r_{fc}^2} + \left(\frac{2P_p r_f^2}{r_{fc}^2 - r_f^2} \right) \frac{E^c}{E^f} \right] /E^c \end{aligned}$$

or solving for P and substituting (5p)

$$\begin{aligned} P &= \left\{ \frac{\Delta r}{r} E^c + 2 \left[\frac{P_e r_c^2}{r_c^2 - r_{fc}^2} + \frac{P_p r_f^2}{r_{fc}^2 - r_f^2} \left(\frac{E^c}{E^f} \right) \right] \right\} \left\{ \nu^c + \frac{r_c^2 + r_{fc}^2}{r_c^2 - r_{fc}^2} \right. \\ &\left. + \left(\frac{r_{fc}^2 + r_f^2}{r_{fc}^2 - r_f^2} - \nu^f \right) \left(\frac{E^c}{E^f} \right) \right\}^{-1} \quad (10p) \end{aligned}$$

The thermal stress contribution has been neglected for these calculations because for extended steady state operation it can be shown that it relaxes to nearly zero due to creep mechanisms.

The pressure calculated by (10p) is limited to the pressure which would cause cladding yield.

Fuel to Cladding Heat Transfer Correlation

The gap conductance calculation was correlated, Figure 15, to data obtained from the P-19 power-to-melt test (Reference 5). The test was designed to provide data necessary to define operating (power) limits for startup conditions. The data provides a well defined indication of fuel temperature (melt location) under

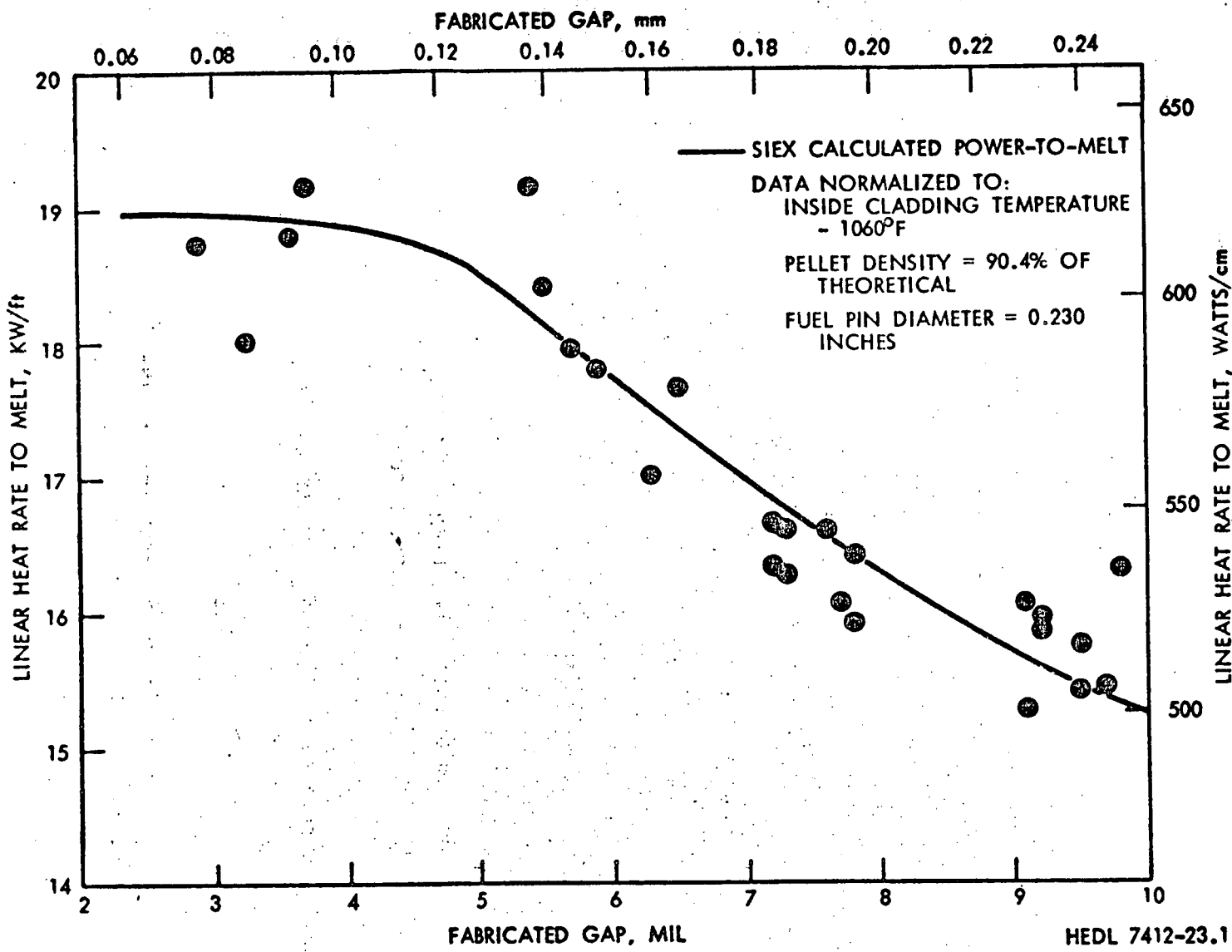

FIGURE 15. SIEX PREDICTED LINEAR HEAT RATE TO INCIPIENT MELT

conditions of well characterized fuel parameters for various fabricated gap widths. Because of the test design, the data represent early-in-life operating history of a fuel pin, thus eliminating major uncertainties in many of the variables (fuel-cladding gap gas composition, hot gap width, burnup effects on fuel conductivity, etc.). This is suggested as the best possible data set to be used for normalizing fuel pin thermal performance to pins under actual irradiation conditions.

The correlation coefficients A and C (a function of interface pressure) in equations 21 and 19 were adjusted to obtain a "best" fit to the data obtained using a Simplex technique to adjust parameters.

The correlation to well defined data, along with postirradiation gap data and a quasi theoretical model for gap conductance, is used to provide estimates of gap conductance throughout the life of the fuel pin.

Figure 16 shows the HGAP flow chart.

STRUCT: Fuel Microstructure (Restructuring) Correlation

Calculation of fuel microstructure characteristics traditionally has proceeded using two different methods. One is a phenomenological approach in which pore migration and coalescence is accounted for. A version of this method has been programmed into the LIFE code (Reference 7). Another method is to find a temperature at which the microstructure stabilizes to a clearly identifiable characteristic. This is sometimes referred to as a grain growth temperature. Such a temperature may be time-dependent, as was reported by Christensen (Reference 18) or a constant. The grain growth method was selected for use in SIEX for two reasons: first, knowing the locations of the grain boundaries and their densities is sufficient to permit calculation of fuel temperature distribution; second, the phenomenological method requires much longer computer times. This is because the calculations must be performed repeatedly at relatively small time intervals to assure that a balance is accurately kept as pores and gas bubbles move across boundaries.

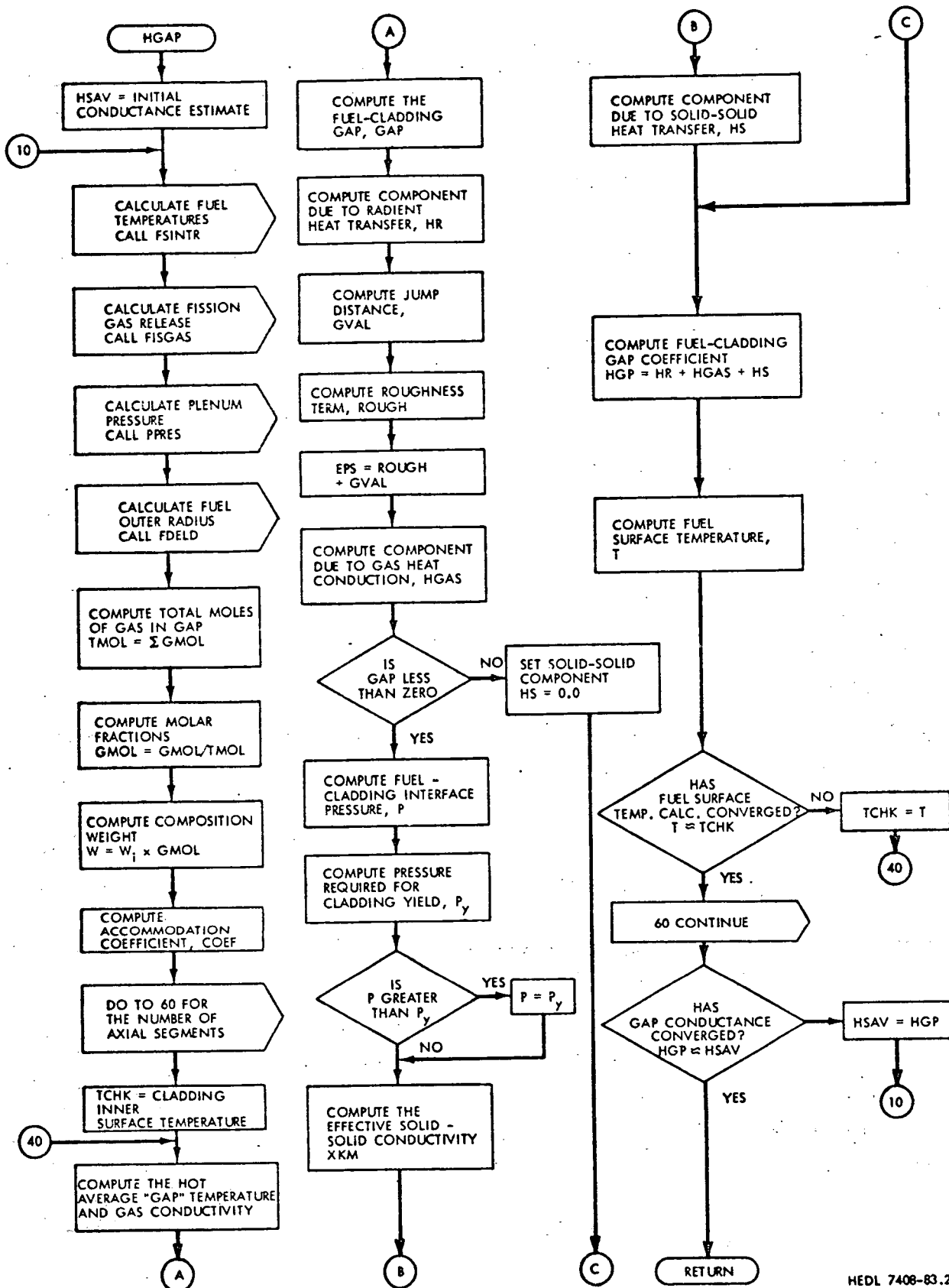

HEDL 7408-83.2

FIGURE 16. HGAP FLOW CHART

The measurements of fuel microstructure, columnar and equiaxed grain growth radii, were taken from photomosaics at the time the previously mentioned "residual gaps" were measured. The columnar grain growth radius was taken to be the extent of observed lenticular voids and columnar (radial elongation) grains. The equiaxed grain growth radius was identified as the region (extent) where equiaxed grains (non-elongated) did not appear to be separated from each other by gas on the grain boundaries.

Temperatures at which columnar and equiaxed grain growth were observed, were calculated for the measured restructuring radii at several burnup levels. In all cases, the maximum temperature occurred on startup (arbitrary burnup of 60 MWd/MTM). Analysis of the data did not show a time dependence of the temperatures used for the prediction of fuel microstructure. A simple statistical analysis of the data was then performed resulting in a gradient dependent function for the "columnar grain growth" and a constant for the "equiaxed grain growth" temperature.

Figures 17 and 18 show the "quality of fit" of the SIEX prediction of the extents of columnar and equiaxed grain growth.

A flow chart of the STRUCT routine is given in Figure 19. In operation, STRUCT predicts fuel microstructure radii at startup. For each succeeding time step the predicted fuel microstructure is compared with the beginning of life microstructure, and the larger of the two is used. Checks to save computation time are incorporated, i.e., if no restructuring had previously been predicted, the comparison would not be executed.

FISGAS: Fission Gas Release Correlation

The SIEX fission gas release model is similar to that presented in Reference 19. A report describing a model closely resembling that in SIEX has recently been published, see Reference 20.

The mechanisms of fission gas release are bubble migration to the central void and diffusion in the high fuel temperature regions, and release through grain boundaries in medium and lower temperature zones. The model assumptions for this analysis are:

- In the fuel region characterized by grain growth, very little

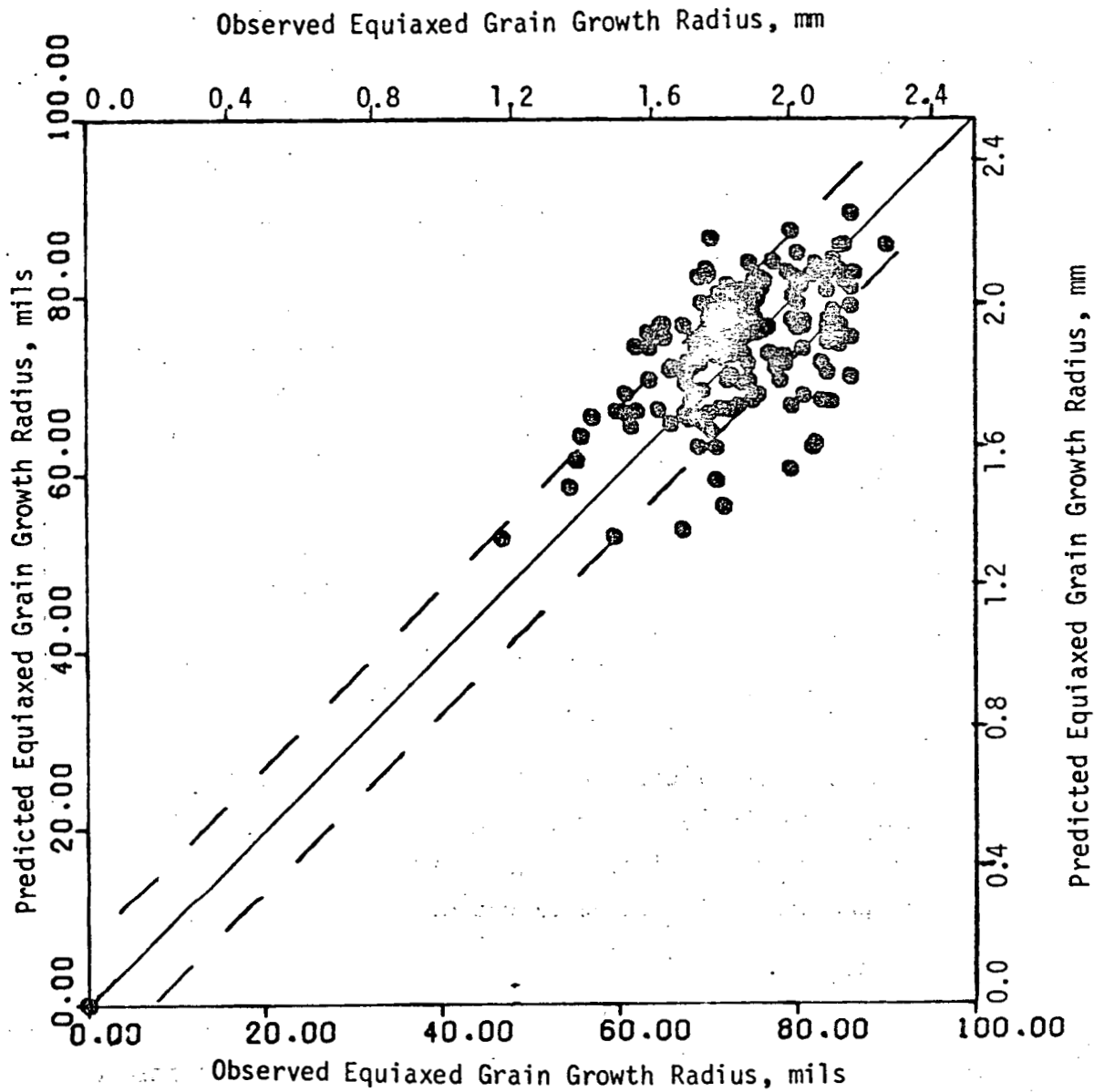

HEDL 7411-28.38

FIGURE 17. EQUIAXED GRAIN GROWTH CORRELATION

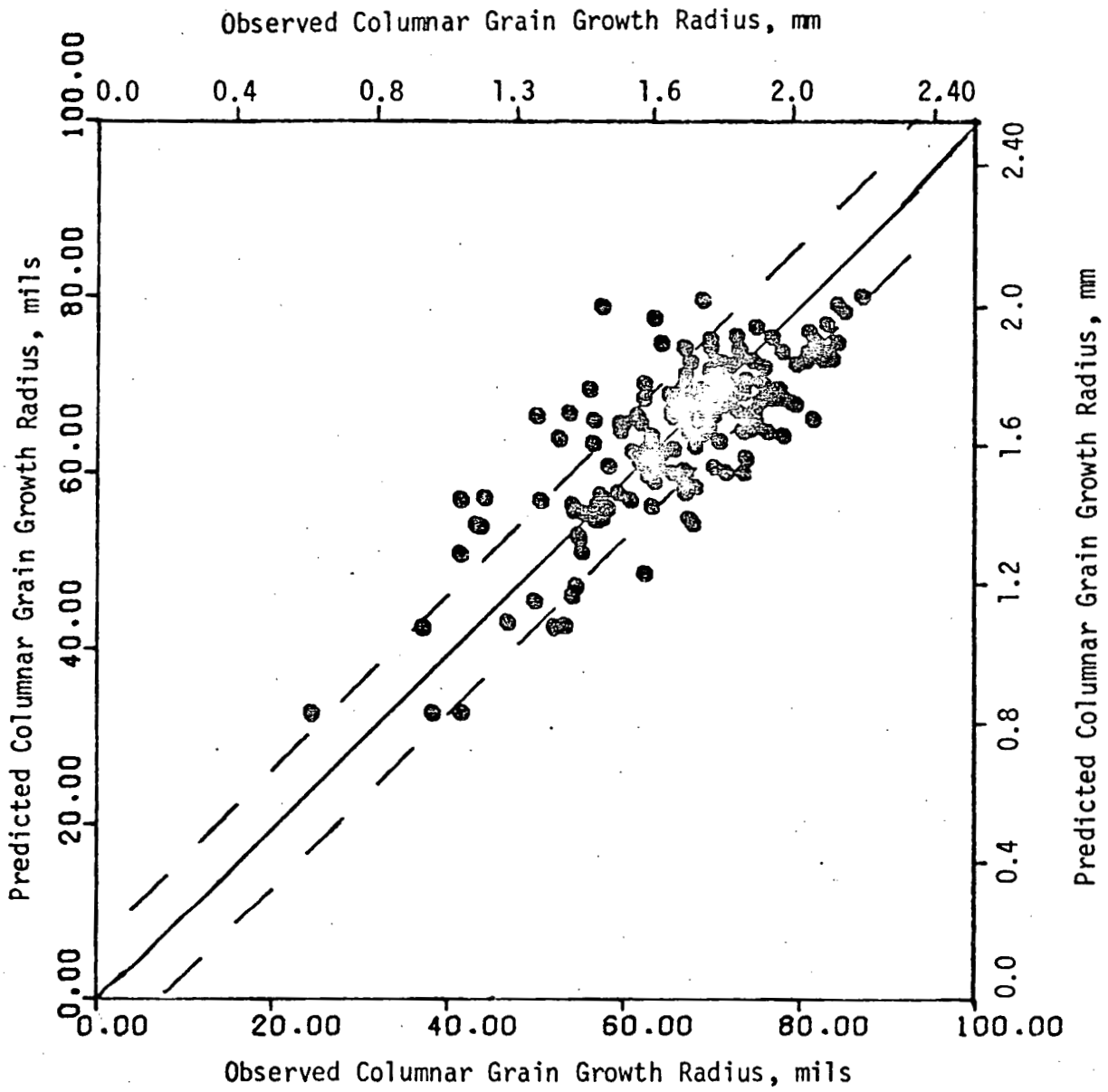

HEDL 7411-28.39

FIGURE 18. COLUMNAR GRAIN GROWTH CORRELATION

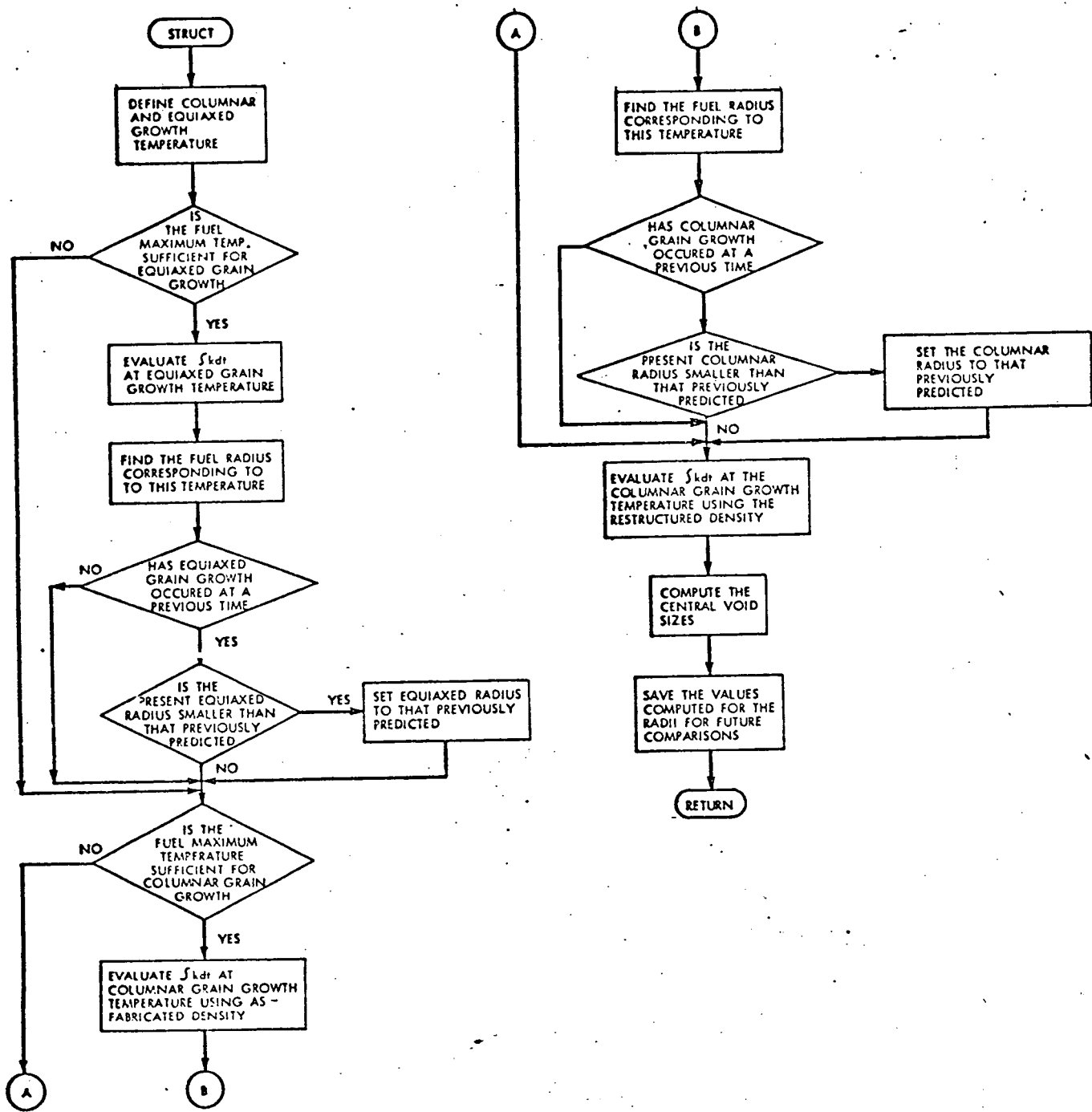

HEDL 7408-83.3

FIGURE 19. STRUCT FLOW CHART

of the generated fission gas can be retained because of high temperature and temperature gradients, and consequently there is rapid diffusion and release of the gases.

- In the unrestructured region, a considerable amount of the generated gaseous fission products is retained. Release is controlled by a combination of thermal and irradiation-induced diffusion processes.
- The fraction of generated gas which is released is then governed by the equation

$$F = F_r A_r + F_u A_u,$$

where F is the total fraction released, F 's and A 's are respectively the release fractions and areas of the restructured and unrestructured regions.

When applying this model, the A 's and F 's are evaluated at each axial node in order to account for axial profiles. Various functional forms of F were investigated during the data analysis.

The data for fission gas release were obtained from fuel elements irradiated in the EBR-II. The total gas recovered from each pin was measured and the percent fission gas identified by mass spectrometry. In all cases a ^{148}Nd chemical analysis was available to determine the fuel element burnup.

The data analysis was done using the regression analysis code REEP, and resulted in the following expressions for the fractional releases from each of the zones:

$$F_r = F_1 + (1 - F_1) \times (1 - F_2 (1 - \exp(-B/F_3))/B)$$

$$F_u = 0, B < F_5$$

$$= 1 - F_4 (1 - \exp(-(B - F_5)/F_5)) \exp(-F_6 \times q_l)/B \times F'(B), B \geq F_5$$

where

B = the local burnup, MWd/kg

q_l = the local linear heat rate, W/cm

$$F'(B) = 1 \quad B > F_7$$

$$= F_8 (B - F_7), \quad B < F_7$$

The FISGAS routine evaluates the area present in each of the three critical regions, the amount of fission gas generated, and also the fraction of fission gas released according to the previous model, at a user specified number of axial segments. The volume of gas released from each segment is then computed, either from input fractional releases or the correlated model. The volume of gas released from each segment is then accumulated over the length of the fuel pin to determine the total volume of gas released to plenum area. This value is then used to compute a "pin" fraction release. A flow chart for FISGAS is shown in Figure 22.

The SIEX predicted fraction release and measured release fractions are plotted in Figure 20 to demonstrate the quality of fit. Figure 21 is an evaluation of the release rate at three different power levels for a fuel pin similar to that of the input example of Section I as a function of burnup. The latter plot demonstrates the burnup behavior of the gas release model and predicted plenum pressures.

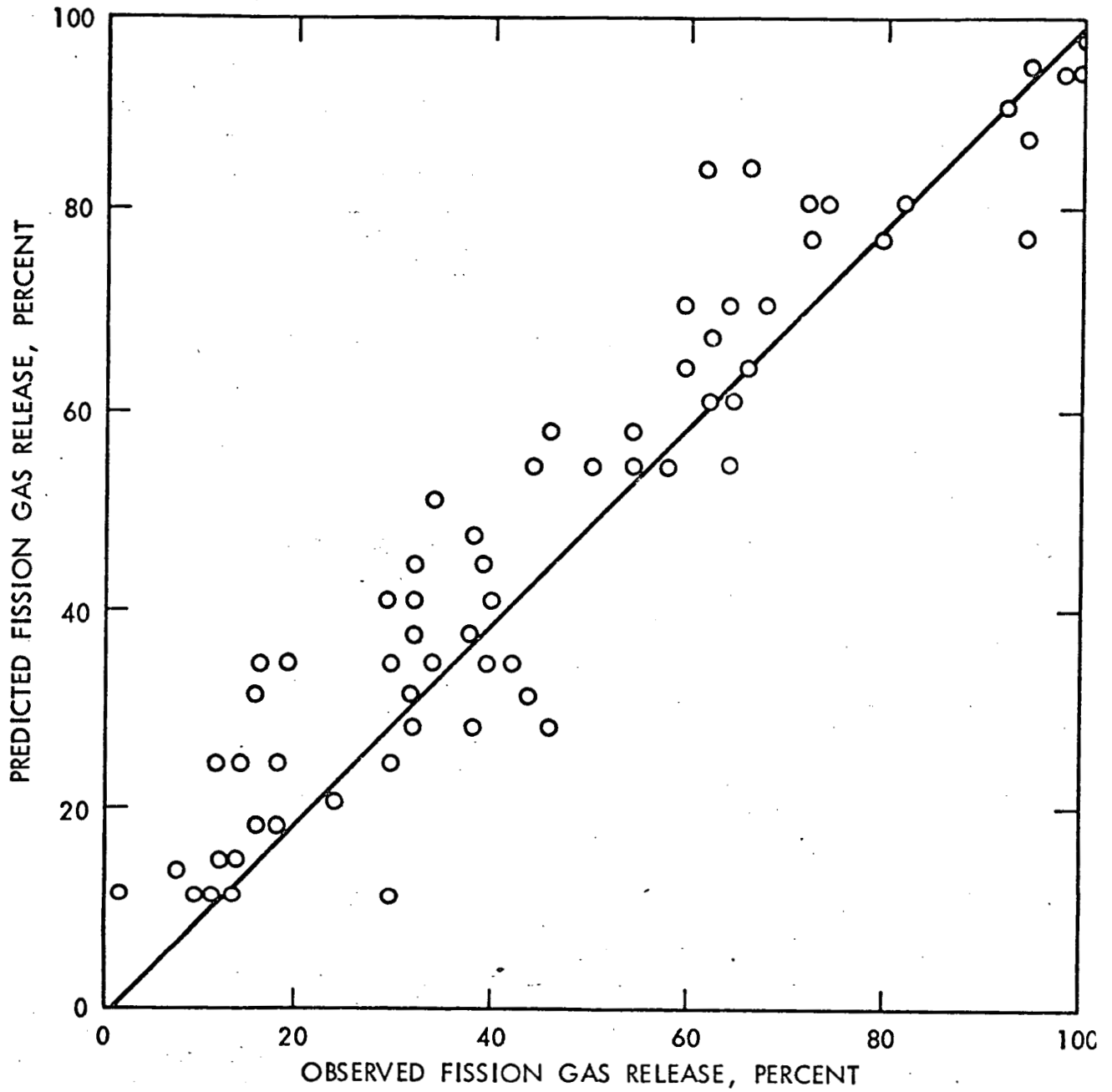

HEDL 7503-148

FIGURE 20. FISSION GAS RELEASE CORRELATION

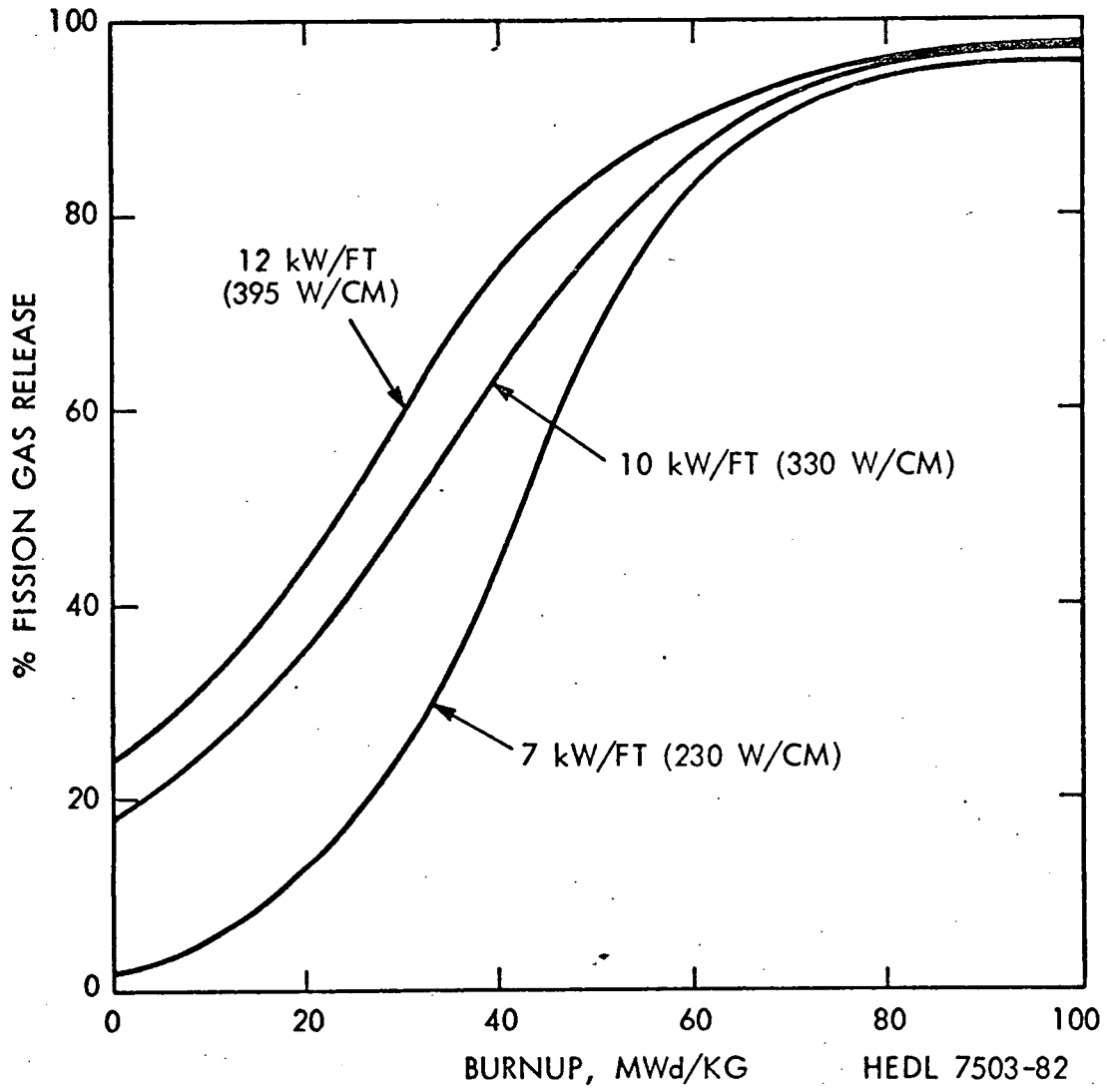

FIGURE 21. FISSION GAS RELEASE VS. BURNUP

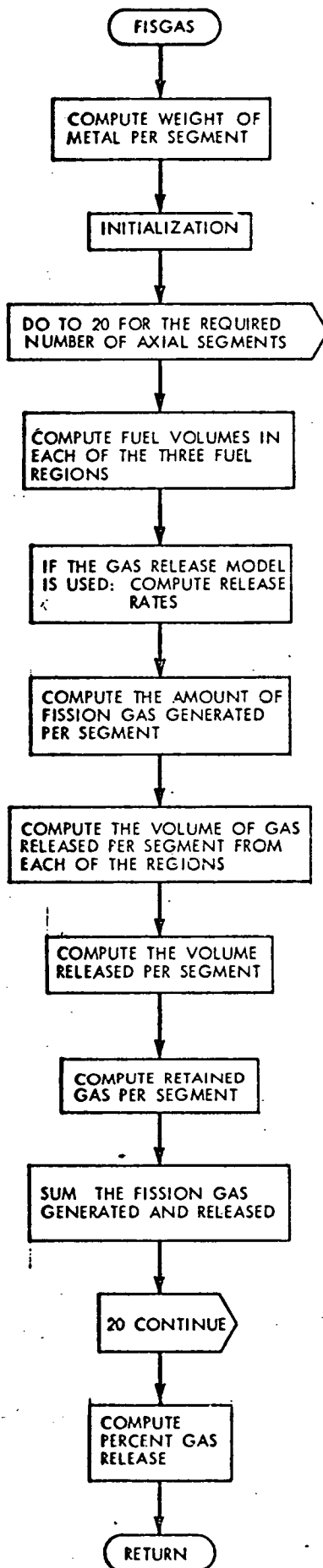

FIGURE 22. FISGAS FLOW

VI. REFERENCES

1. S. Glasstone and A. Sesonske, "Nuclear Reactor Engineering", Van Nostrand Reinhold Co., New York, 1967.
2. K. R. Merx and G. L. Fox, "SINTER - A Program for Calculating Radial Temperature Distributions in Oxide Fuel Pins Undergoing Sintering," BNWL - 1241, UC-80, January, 1970.
3. J. B. Scarborough, "Numerical Mathematical Analysis," John Hopkins Press, Baltimore, Md., 1966.
4. J. F. Bates and J. L. Straalsund, "A Compilation of Data and Empirical Representations of Irradiation Induced Swelling of Solution Treated Types 304 and 316 Stainless Steel," HEDL, Richland, Wa., HEDL-TME 71-139, September, 1971.
5. R. D. Leggett, R. B. Baker, E. O. Ballard, G. R. Horn, D. S. Dutt, "Linear Heat Rating for Incipient Fuel Melting in UO_2 - PuO_2 Fuel," Trans. Amer. Nucl. Soc., Volume 15, No. 2, p. 752, 1972.
6. D. S. Dutt, R. B. Baker, S. A. Chastain, "Modeling of the Fuel-Cladding Postirradiation Gap in Mixed Oxide Fuel Pins," Trans. Amer. Nuc. Soc., Volume 17, No. 2, p. 1975, 1973.
7. V. F. Jankus and R. W. Weeks, "LIFE-II - A Computer Analysis of Fast-Reactor Fuel-Element Behavior as a Function of Reactor Operating History," First International Conference on Structural Mechanics in Reactor Technology, Berlin, Germany, September 20-24, 1971.
8. David F. Shanno, "REEP-Nonlinear Estimation Package," IBM Share Program Library, January 27, 1967.
9. C. M. Cox, F. J. Homan, R. L. Diamond, "LMFBR Fuel Cycle Progress Report," ORNL-TM-3759, February, 1972.
10. G. R. Horn and F. E. Panisko, "Users' Guide for GAPCON: A Computer Program to Predict Fuel-to-Cladding Heat Transfer Coefficients in Oxide Fuel Pins," HEDL-TME 72-128, September, 1972.
11. E. R. G. Echert, "Heat and Mass Transfer," McGraw Hill, New York, 1959.
12. A. M. Ross and R. L. Stoute, "Heat Transfer Coefficient Between UO_2 and Zircolloy 2," AECL-1552, June 1962.
13. E. H. Kennard, "Kinetic Theory of Gases," McGraw Hill, New York, p. 311, 1938.
14. "Handbook of Chemistry and Physics," 43rd Edition, Chemical Rubber Publishing Company, Cleveland, Ohio, p. 2167 (1961).
15. R. S. Brokaw, "Estimating Thermal Conductivities for Non-Polar Mixtures: Simple Empirical Method," Ind. Eng. Chem 47 (11), pp. 2398-2400, 1955.

16. R. Godesar, "COMETHE-II - A Computer Code for Predicting the Mechanical and Thermal Behavior of a Fuel Pin," Nuclear App. and Tech., Volume 9, p. 205, August, 1970.
17. Charles O. Harris, "Introduction to Stress Analysis," MacMillian Company, New York, 1963.
18. J. A. Christensen, "Columnar Grain Growth in Oxide Fuels," Trans. Amer. Nucl. Soc., Vol. 15, No. 1, June, 1972.
19. D. S. Dutt, D. C. Bullington, R. B. Baker, L. A. Pember, "A Correlated Fission Gas Release Model for Fast Reactor Fuels," Trans. Amer. Nucl. Soc., Vol. 15, No. 1, June, 1972.
20. K. Ehrlich, et. al, "UO₂PuO₂ Fuel Pin Irradiation in Trefoil Insert DFR-304 Evaluation of the Investigation Results on Irradiated Fuel Rods," EURFNR-1151, January, 1974.
21. Fast Flux Test Facility Material Design Data, BNWL-891 (Section A1-301.1), October, 1968.
22. Ibid. (Section A3-205.1)
23. Ibid. (Section A 205.5)
24. Ibid. (Section A3-301.2)
25. M. M. Paxton, "Mechanical Properties of Prototype FTR Cladding-20% C.W. 316 Stainless Steel Tubing," (App. A & B), HEDL-TME 71-59 Hanford Eng. Develop. Lab., Richland, Washington, April, 1971.
26. "Handbook of Chemistry and Physics." 43rd Edition, Chemical Rubber Publishing Company, Cleveland, Ohio, 1961. P. 3041.
27. J. B. Conway, R. M. Fincel, Jr., and R. A. Hein, "The Thermal Expansion and Heat Capacity of UO₂ to 2000°C," Trans. Amer. Nucl. Soc., Vol. 6, p. 153, 1963.
28. E. Duncome, J. E. Meyer and W. A. Coffman, "Comparisons with Experiment of Calculated Dimensional Changes and Failure Analysis of Irradiated Bulk Oxide Test Rods using the CYGRO-1 Computer Program," WARD-TM-583, 1966.
29. F. E. Bard, B. C. Gneiting, and C. M. Cox, "A Thermoelastic Material Properties Correlation for Uranium/Plutonium Mixed Oxides," HEDL-TME 74-12 Hanford Engineering Development Laboratory, Richland, .., Washington, Feb., 1974.
30. J. Belle, "Uranium Dioxide: Properties and Nuclear Applications," Naval Reactors, Division of Reactor Development, USAEC, U.S. Government Printing Office, 1961.

31. ENDF/B Nuclear and Cross Section Files, Version 4, Available From Brookhaven National Laboratory.
32. A. C. Rapiet, T. M. Jones, and J. E. McIntosh, "The Thermal Conductance of UO_2 /Stainless Steel Interfaces," Int. J. Heat and Mass Transfer 6, pp. 397-416. 1963.
33. J. H. Kittel, "Guide for Irradiation Experiments in EBR-II," Revision 4, Argonne National Laboratory, Argonne, Illinois, February, 1971.
34. P. E. Liley, "The Thermal Conductivity of 46 Gases at Atmosphere" Pressure, Proc. Fourth p. on Thermophysical Properties, College Park, MD., April, 1968, J. R. Mozynski Ed. ASME, 345 E. 47th Street.
35. K. A. Varteressian and Leslie Burris, "Fission-Product Spectra from Fast and Thermal Fission of ^{235}U and ^{239}Pu ," ANL-7678, March, 1970.
36. HEDL Fast Reactor Materials Dosimetry Center, 1972.
37. J. Jedruch and R. J. Nodvik, "Experimentally Determined Burnup and Spent Fuel Composition of Yankee Core I.," Westinghouse Electric Corporation, Pittsburgh, Pa., Atomic Power Division, July, 1965, Table 7.4, p. 62, WCAP 6071.

APPENDIX A GLOSSARY

Symbol	FORTRAN Equivalent	Description	Code Units	Input/Output
α^C		Cladding mean coefficient of thermal expansion ($\alpha^C = \alpha_0^C + \alpha_T^C$)	cm/cm-°C	in/in-°F
α_0^C	ALPHA0	Intercept in the linear equation for the mean coefficient of thermal expansion	cm/cm-°C	in/in-°F
α_T^C	ALPHAS	Slope in the linear equation for the mean coefficient of thermal expansion	cm/cm-°C ²	in/in-°F ²
B		Local Burnup	Mwd/kg	MWd/kg
	BU(I)	Burnup in an axial segment	MWd/MTM	MWd/MTM
	BUI(I)	Burnup increment in an axial segment	MWd/MTM	MWd/MTM
	CCPGM	Sorbed gas in fabricated fuel	cc/gm of oxide	cm/gm of oxide
T_i^C	CLIDT(I)	Cladding inner surface temp.	°C	°F
T_o^C	CLODT(I)	Cladding outer surface temp.	°C	°F
a	COEF	Accommodation Coefficient	--	--
K^C	CK	Cladding conductivity	W/cm-°C	Btu/hr-ft-°F
M_F	CMF	Coolant mass flow rate	gm/sec	lb/hr
G'	COLDGP(I)	Fuel-cladding radial gap (postirradiation)	cm	inches
	CRATIO(L)	User Specified coolant mass flow rate ratio (for unequal time steps)	--	--
t	CT	Cladding wall thickness	cm	inches
k_i	CON	Conductivity of gas components	W/cm-°C	Btu/hr-ft-°F

GLOSSARY (Continued)

Symbol	FORTTRAN Equivalent	Description	Code Units	Input/Output Units
C_p	CP	Coolant specific heat	W-sec/ gm-°C	Btu/lb-°F
C	CY	Number of reactor cycles	--	--
	DENHI	Fraction of theoretical density of the columnar grain growth region	--	--
	DENLO	Fraction of theoretical density of the as-fabricated fuel	--	--
$\% \Delta V/V_c$	DELTAD(I)	Cladding irradiation induced swelling	percent	percent
	DISH	Fraction of the fuel column volume occupied by the dished ends of the pellets.	--	--
r'_F	DFSWEL(I)	"Hot" fuel radius	cm	inches
	DP	Cladding outer diameter	cm	inches
r'_C	DPSWEL(I)	"Hot" outer cladding radius	cm	inches
	E	Extrapolation distance for axial power profile	cm	inches
E_C		Cladding Young's modulus, $E_C = E_0 + E_T$	dynes/cm ²	lb/in ²
E_f		Fuel Young's modulus	dynes/cm ²	lb/in ²
	EPL	Effective plenum length	cm	inches
	EFPD	Equivalent Full Power Days	EFPD	EFPD
V	EPV	"Effective" plenum volume	cc	cc
P_e	EXTERP	External cladding pressure	dynes/cm ²	lb/in ²
	FD	Fuel pellet diameter	cm	inches
	FLEN	Active fuel column length	cm	in
ϕt	FLUENCE (I)	Fluence at each axial node (Energy > .1 MeV)	Neutrons/ cm ²	Neutrons/cm ²

GLOSSARY (Continued)

Symbol	FORTTRAN Equivalent	Description	Code Units	Input/Output Units
	FLUNCI(I)	Fluence at each axial node (Energy > .1 MeV)	Neutrons/cm ²	Neutrons/cm ²
	FN	Fraction of the sorbed gas which is not helium or hydrogen. This gas is assumed to have the physical characteristics of the nitrogen.	--	--
G		Fabricated fuel cladding gap	cm	inches
X _i	GMOL(K)	Moles of each gas component present in the fuel-cladding gap	Moles or molar fraction	Moles
g	GVAL	"Jump" distances for calculation of fuel to cladding heat transfer coefficient	cm	inches
H	HF	Cladding to coolant heat transfer coefficient	W/cm ² -°C	Btu/hr-ft ² -°F
	HG	Constant fuel to cladding heat transfer coefficient (input)	W/cm ² -°C	Btu/hr-ft ² -°F
H _{gas}	HGAS	Component of fuel to cladding heat transfer coefficient due to conductance across the gap	W/cm ² -°C	Btu/hr-ft ² -°F
h	HIGHT	Fuel segment length	cm	inches
	HGP(I)	Calculated fuel to cladding heat transfer coefficient	W/cm ² -°C	Btu/hr-ft ² -°F
C	HG1	Gap conductance correlation coefficient	--	--
	HG2	Gap conductance correlation coefficient	--	--
A	HG3	Gap conductance correlation coefficient	--	--
H _s	HS	Component of fuel to cladding heat transfer coefficient due to radiant heat transfer	W/cm ² -°C	Btu/hr-ft ² -°F
H _r	HR	Component of fuel to cladding heat transfer coefficient due to solid to solid heat transfer	W/cm ² -°C	Btu/hr-ft ² -°F

GLOSSARY (Continued)

Symbol	FORTTRAN Equivalent	Description	Code Units	Input/Output Units
	ITAB1	Output option selector for fission gas release calculation output	--	--
	ITAB2	Output option selector for geometry changes	--	--
	ITAB3	Output option selector for gap conductance calculation	--	--
	ITAB4	Output option selector for cladding elastic stress option	--	--
k^f		Fuel thermal conductivity	W/cm-°C	Btu/hr-ft-°F
	KRFIL	Percent of Krypton in the fill gas	--	--
q_l	P(I)	Linear heat rate	W/cm	kW/ft
	PBU	Peak fuel burnup	MWd/MTM	MWd/MTM
	PFLUX	Peak (axial) neutron flux (greater than 0.1 MeV)	Neutrons/cm ² -sec	Neutrons/cm ² sec
P	PGAP	Fuel-cladding interface pressure	dynes/cm ²	lb/in. ²
	PGR	Percent fission gas release	Percent	Percent
P_p	PLENP	Plenum pressure-fuel void pressure	dynes/cm ²	lb/in. ²
	PM	Peak linear heat rate Linear heat	W/cm	kW/ft
ν^c	PNU	Cladding Poisson's ratio	--	--
ν_f		Fuel Poisson's ratio	--	--
	PPM	Fuel water vapor content	ppm	ppm
	PRATIO(K)	Power ratio applying to a time interval	--	--

GLOSSARY (Continued)

Symbol	FORTTRAN Equivalent	Description	Code Units	Input/Output Units
q	PTERM	Volumetric heat generation rate of the undensified fuel	W/cm ³	Btu/ft ³ -hr
	PU	Fraction of the metal in the fuel which is either ²³⁹ Pu or ²⁴¹ Pu	--	--
r	R(L)	Radius of fuel nodes (10) for temperature calculations	cm	inches
r _b	RBX(I)	Columnar grain growth radius	cm	inches
r _c	RCX(I)	Central void radius (restructured)	cm	inches
	RETFG(I)	Fission gas retained in the fuel	cc/gm of oxide	cc/gm of oxide
r _e	REX(I)	Equiaxed grain growth radius	cm	inches
r _o ^c		Cladding outer radius	cm	inches
r _i ^c	RIDP	Cladding inner radius	cm	inches
	RISWEL(I)	"Hot" inner cladding radius	cm	inches
r _m	RM	Fabricated central void radius	cm	inches
	RMELT(I)	Fuel melt extent (radial)	cm	inches
r _o	RO	Outer fuel radius	cm	inches
	RT(J,I)	Radial and axial fuel temperature distribution	°C	°F
S(r)	S	Integral Kdt evaluated at radius r	W/cm	Btu/hr-ft
	SEGNUM	Number of axial segments	--	--
	STEPS	Number of time intervals at which calculations/output is desired	--	--
	TB	Columnar grain growth temperature if constant value is used (Input)	°C	°C

GLOSSARY (Continued)

Symbol	FORTTRAN Equivalent	Description	Code Units	Input/Output Units
	TC(I)	Maximum fuel temperature	°C	°F
T_b	TCG(I)	Columnar grain growth temperature	°C	°C
	TCL(I)	Maximum fuel temperature (unrestructured)	°C	°F
T_c	TCOOL(I)	Coolant temperature	°C	°F
	TD	Fuel theoretical density	gm/cc	gm/cc
T_e	TEG(I)	Equiaxed grain growth temperature	°C	°C
	TEMP2	Equiaxed grain growth temperature if constant value is used (input)	°C	°C
	TI	Coolant inlet temperature	°C	°F
	TIINCR(L)	Time increments to be used for calculation or output	Equiv. full power days	Equiv. full power days
T_m	TBAR	Average temperature of the gas in the fuel-cladding gap	°C	°F
	TMSWC	Cladding material indicator	--	--
	TMTM	Calculated weight of metal in the fuel column	Metric ton	Metric ton
V_r	TOTFGR	"Pin" volume of fission gas released	cc @ STP	cc @ STP
	TVFGR(I)	Volume of fission gas released in each axial segment	cc @ STP	cc @ STP
T_f	TZ	Fuel surface temperature	°C	°F
	U_{235}	Fraction of the metal in the fuel which is ^{235}U	--	--
	VFG(I)	Volume of fission gas generated in each axial segment	cc @ STP	

GLOSSARY (Continued)

Symbol	FORTTRAN Equivalent	Description	Code Units	Input/Output Units
	VFGR(K,I)	Volume of fission gas released in each region at each axial segment	cc @ STP	cc @ STP
V_f	VOFG	Volume of fill gas	cc @ STP	cc @ STP
	VOID	Fabricated fuel central void diameter	cm	inches
V_s	VSG	Volume of sorbed gas in fuel excluding water vapor	cm @ STP	cc @ STP
V_w	VWV	Volume of water vapor in fuel	cc @ STP	cc @ STP
\bar{W}	WBAR	Average molecular weight of the gas in the fuel-cladding gap	gm/mole	gm/mole
	X(I)	Distance above the bottom of the fuel of the center of each axial segment (the location of the axial nodes)	cm	inches
	XEFIL	Percent of xenon in the fill gas	--	--
K_s	XKM	Effective solid to solid conductivity	W/cm-°C	Btu/hr-ft-°F
K_{tm}	XKMIX	Conductivity of the gas in the fuel-cladding gap	W/cm-°C	Btu/hr-ft-°F
Y		Cladding yield strength	dynes/cm ²	lb/in ²
E_o	YMOD0	Intercept of the linear expression for cladding Young's modulus	dynes/cm ²	lb/in ²
E_t	YMODS	Slope of the linear expression for cladding Young's modulus	dynes/cm ² -°C	lb/in ² -°F

GLOSSARY (Continued)

Symbol	FORTRAN Equivalent	Description	Code Units	Input/Output Units
F_c	Z1	Fraction of produced fission gas released from columnar grain growth region	--	--
F_e	Z2	Fraction of produced fission gas released from equiaxed grain growth region	--	--
F_u	Z3	Fraction of produced fission gas released from the unstructured fuel region	--	--

APPENDIX B

Material Properties and Correlation

Coefficient Values

Current values used for material properties and correlated model coefficients are given in the following table. These values are programmed into SIEX in the form of data statements located in the routine BLKDAT and transferred to the respective models through the labeled common PARCOM. References and code units are given where appropriate.

TABLE B.1

MATERIAL PROPERTY AND CORRELATION COEFFICIENT VALUES

<u>Model/Parameter</u>	<u>FORTTRAN Equivalent</u>	<u>Value/Units</u>
Cladding Thermal Expansion	(Reference 21)	
α_0^C	ALPHAO	16.2×10^{-6} (cm/cm - °C)
α_T^C	ALPHAS	3.79×10^{-9} (cm/cm - °C ²)
Cladding Young's Modulus	(Reference 22)	
E_0^C	YMOD0	2.12×10^{12} (dynes/cm ²)
E_T^C	YMODS	9.2×10^8 (dynes/cm ² - °C)
Cladding Poissons Ratio	(Reference 23)	
γ^C	PNU	.3
Cladding Thermal Conductivity	(Reference 24)	
K_0^C	CK1	0.133 (W/cm - °C)
K_T^C	CK2	1.300×10^{-4} (W/cm - °C ²)
Cladding Yield Strength	(Reference 25)	
--	YEO	4.82×10^9 (dynes/cm ²)
--	YES	-1.076×10^7 (dynes/cm ² - °C)
Cladding Emissivity	(Reference 26)	
ϵ_C	EMC	.9

TABLE B.1 (Continued)

Fuel Thermal Expansion

(Reference 27)

α_0^f	FALFO	6.58×10^{-6} (cm/cm $^{\circ}\text{C}$)
α_T^f	FALFT	3.00×10^{-9} (cm/cm $^{\circ}\text{C}^2$)

Fuel Young's Modulus

(Reference 28)

E_0^f	YMODFO	2.50×10^{12} (dynes/cm 2)
E_T^f	YMODFS	4.46×10^8 (dynes/cm 2 $^{\circ}\text{C}$)

Fuel Poisson's Ratio

(Reference 29)

γ^f	PNU	.3
------------	-----	----

Fuel Thermal Conductivity

(Reference 4)

K_p^f	FKD	1.133
K_1^f	FK1	.78
K_2^f	FK2	.02935
K_3^f	FK3	6.60×10^{-13}

Fuel Emissivity

(Reference 30)

ϵ_c	EMF	.80
--------------	-----	-----

Gas Conductivities (See Table B.2)

Postirradiation Gap (Correlation)

G_1	RG1	3.87×10^{-6}
G_2	RG2	126.
G_3	RG3	-.522
G_4	RG4	.395
G_5	RG5	-.01684
G_6	RG6	.600
G_7	RG7	1.1×10^{-5}

Fuel to Cladding
Heat Transfer (Correlation):

A	HG1	13.7
---	-----	------

TABLE B.1 (Continued)

Fuel to Cladding Heat Transfer (Correlation) (Cont.):

C	$C = HG2 \times \exp(-HG3 \times P)$	
	HG2	1.1095
	HG3	-3.394×10^{-9}

Grain Growth Temperatures (Correlation)

Equiaxed grain growth temperature	FR1	1570. (°C)
Columnar grain growth temperature	FR2	1886. (°C)
	FR3	0.49 (°C - cm/W)

Fission Gas Yield (Reference 31)

Xenon from ²³⁹ Pu	FYPUX	0.233 (atoms/fission)
Krypton from ²³⁹ Pu	FYPUK	0.022 (atoms/fission)
Xenon from ²³⁵ U	FYU5X	0.218 (atoms/fission)
Krypton from ²³⁵ U	FYU5K	0.048 (atoms/fission)
Xenon from ²³⁸ U	FYU8X	0.214 (atoms/fission)
Krypton from ²³⁸ U	FYU8K	0.031 (atoms/fission)

Fission Gas Release (Correlation)

F ₁	FG1	5890.
F ₂	FG2	0.86498
F ₃	FG3	3515.
F ₄	FG4	7.345
F ₅	FG5	49170.
F ₆	FG6	-2.88×10^{-4}
F ₇	FG7	0.0824
F ₈	FG8	0.0125

Accommodation Coefficient (Correlation),

A ₁	AC1	0.8121
A ₂	AC2	4.516
A ₃	AC3	7.714

TABLE B.1 (Continued)

Cladding Roughness	(Reference 12)	
r_c		1.78×10^{-4} (cm)
Fuel Roughness	(Reference 32)	
r_f		3.3×10^{-4} (cm)

The values used for the EBR-II axial flux profile, axial power profile, average neutron energy, and ratio of total flux to flux greater than .1 MeV were obtained from Reference 33. These values are used when the appropriate option for axial profiles is selected. See page 13 for details.

TABLE B.2

GAS CONDUCTIVITIES (Reference 34)

For Gas Conductivity Expressed As:

$$k_i = A + BT + CT^2, \frac{\text{watts}}{\text{cm} \cdot ^\circ\text{C}}; T \text{ in } ^\circ\text{C}$$

<u>Coefficient</u>	<u>Helium</u>	<u>Nitrogen</u>	<u>Xenon</u>	<u>Argon</u>	<u>Krypton</u>
A	1.308×10^{-3}	2.540×10^{-4}	5.739×10^{-5}	1.716×10^{-4}	9.560×10^{-5}
B	3.696×10^{-6}	5.651×10^{-7}	1.451×10^{-7}	4.122×10^{-7}	2.136×10^{-7}
C	-5.848×10^{-10}	-7.336×10^{-11}	-2.323×10^{-11}	-8.015×10^{-11}	-3.506×10^{-11}

		SUBROUTINE SINPUT(DENMI, DENLO)	8	28
	C	COMMON/PARCOM/	8	29
		* MG1, MG2, MG3, MG4, A1, A2, A3, RG1, RG2, RG3, R50, R65, R66, RG7,	8	30
9		* FYUS1, FYUS4, FYUS, FYUBX, FYURK, FYUB, FYPLX, FYPUK, FYPU,	8	31
		* CSU215, CSU230, CSPU, EU215, EU230, EPU, ELCAMA,	8	32
		* FG1, FG2, FG3, FG4, FG5, FG6, FG7, FGB, FRI, FRP, FR3,	8	33
		* CK1, CK2, YEO, YES, YMODFO, YMODFS, FK1, FK2, FK3, FKD, FALFO, FALFT	8	34
	C	COMMON/TBLS2/ST(2,10), NT1, NT2, TCENT(17), C(2,4)	8	35
10		DO 60 I=1,2	8	36
		IF(I, EQ, 1) D=DENLO	8	37
		IF(I, EQ, 2) D=DENHI	8	38
		C(I, 1)=FKD*D/(1.+(1.+10.*D))+(1.-D)	8	39
15		C(I, 2)=FK2	8	40
		C(I, 3)=FK1	8	41
		C(I, 4)=FK3*.25	8	42
	60	CONTINUE	8	43
	C		8	44
20		GENERATE TABLE TO GIVE T AS FUNCTION OF INTEGRAL K DT	8	45
	C		8	46
		NTM1=NT1-1	8	47
		DO 80 II=1,2	8	48
		I=II	8	49
25		DO 70 J=1, NTM1	8	50
	70	ST(I, J)=S(TCENT(J), I)	8	51
		ST(I, NT1)=S(TCENT(NT1), I)	8	52
	80	ST(I, NT1+1)=-1000.	8	53
		RETURN	8	54
30		END	8	55
			8	56
			8	57

```

      I = J
      -----
60  C FUEL SURFACE TEMPERATURE
      C -----
      TZ=CLTOT(J)*P(J)/(HGP(J)+P1*RIDP)
      C
      C EVALUATE INTEGRAL K DT AT FUEL SURFACE TEMP STEP 5
65  C SLOTO=S(TZ,1)
      C CALCULATE CENTER LINE TEMP WITHOUT SINTERING STEP 6
      SLOTC= SLOTO+PTERM1*((.5*RO2-.5*RM2+RM2+ALOG(RO/RM))
      TCL(J)=T(SLOTC,1)
      C -----
70  C DETERMINE THE FUEL MICROSTRUCTURE
      C -----
      CALL STRUCT(SLOTO,SMOTB,J,ISAV)
      TC(J)=TCL(J)
      IF(PBX(J),LF,RM) GO TO 20
75  C -----
      C DETERMINE THE FULL CENTER TEMPERATURE WITH RESTRUCTURING
      C -----
      PTERM2=PTERM1*DFNMI/DENLO
80  C SMTBIC=PTERM2*((.5*RBX(J)**2-.5*RCX(J)**2-RCX(J)**2+ALOG(RBX(J)
      /RCX(J)))
      SMOTC = SMOTB + SMTBIC
      TC(I)=T(SMOTC,2)
      C
      C DETERMINE THE EXTENT OF MELTING (IF IT OCCURS)
85  C
      C IF(TC(I),LT,2760.) GO TO 20
      SLOTH=S(2760.,2)-SMOTB
      RMLT(J)=HFIND(SLOTH/PTERM2,RBX(J),RCX(J))
      GO TO 30
90  20 RMLT(I)=RM
      30 CONTINUE
      C -----
      C COMPUTE THE COMPLETE RADIAL TEMPERATURE DISTRIBUTIONS AT TEN
      C EQUALLY SPACE NODES
95  C -----
      KUP=9,-AINT(RCX(J)/DELR)
      TR=TZ
      DO 70 K=1,KUP
      RT(K,I)=TR
      IF(PBX(J)-R(K+1)) 40,50,60
      TR=1*((.5*RO2-.5*R(K+1)**2+RM2+ALOG(RO/R(K+1)))+PTERM1+SLOTO,1)
      GO TO 70
      40 TR = TCG(J)
      GO TO 70
      50 TR=1*((.5*RBX(J)**2-.5*R(K+1)**2-RCX(J)**2+ALOG(RBX(J)/R(K+1)))
      +PTERM2+SMOTB,2)
      60 CONTINUE
      KUP=KUP+1
      DO 80 K=KUP,10
      RT(K,I)=TR
      70 TR=TC(I)
      80 CONTINUE
      90 CONTINUE
      C
      RETURN
      FSINTR 34
      FSINTR 35
      FSINTR 36
      FSINTR 37
      FSINTR 38
      FSINTR 39
      FSINTR 40
      FSINTR 41
      FSINTR 42
      FSINTR 43
      FSINTR 44
      FSINTR 45
      FSINTR 46
      FSINTR 47
      FSINTR 48
      FSINTR 49
      FSINTR 50
      FSINTR 51
      FSINTR 52
      FSINTR 53
      FSINTR 54
      FSINTR 55
      FSINTR 56
      FSINTR 57
      FSINTR 58
      FSINTR 59
      FSINTR 60
      FSINTR 61
      FSINTR 62
      FSINTR 63
      FSINTR 64
      FSINTR 65
      FSINTR 66
      FSINTR 67
      FSINTR 68
      FSINTR 69
      FSINTR 70
      FSINTR 71
      FSINTR 72
      FSINTR 73
      FSINTR 74
      FSINTR 75
      FSINTR 76
      FSINTR 77
      FSINTR 78
      FSINTR 79
      FSINTR 80
      FSINTR 81
      FSINTR 82
      FSINTR 83
      FSINTR 84
      FSINTR 85
      FSINTR 86
      FSINTR 87
      FSINTR 88
      FSINTR 89
      FSINTR 90

```

86

```

SUBROUTINE FISGAS(IS)
C
C FISGAS COMPUTES THE VOLUME OF GAS GENERATED,RELEASED TO THE PLENUM
C AND RETAINED IN THE FUEL.
5
C
C VARIABLES DEFINED IN FISGAS
C VFG(J) -VOLUME OF FISSION GAS GENERATED FOR EACH FUEL SEGMENT
C VFGR(I,J) -VOLUME OF FISSION GAS RELEASED FROM EACH SEGMENT
C TOTFGR -TOTAL VOLUME OF FISSION GAS RELEASED TO THE PLENUM
10
C PGR -PER CENT OF THE FISSION GAS GENERATED WHICH IS RELEA
C RETFG(J) -VOLUME OF FISSION GAS RETAINED IN THE FUEL
C
REAL KRFIL
COMMON/INPT/FLEN,E,FD,VOID,DP,CT,PH,CHF,CP,HF,HG,CK,TI,TB,TEMP2,
15
1 DENLO,DENHI,TD,DISH,PU,U235,SEGNM,PBU,EPD,STEPS,Z1,Z2,Z3,
3 CCPGM,FN,PPM,EPL,XEFIL,KRFIL,ALPHA0,ALPHAS,
3 YMOD0,YMODS,PNU,PFLUX,TMSWC,EXTERP,ITAB1,ITAB2,ITAB3,ITAB4,
4 TIINCR(10),PRATIO(10),CRATIO(10)
COMMON/PRX/RO,RH,R02,RM2,FIIDP,PB2,RC2,NSEG,DELR,TMTM,NSEGM1,MIGHT,
20
1 FU235,FU238,FPU,EFBAR,PIERM1,PI,PIT2,
2 R(10),X(22),PEX(22),RBX(22),RCX(22),RBSAV(22),RESAV(22),RHLT(22),
3 RR0SQ(22),
3 P(22),HGP(22),RT(10,22),CLOUD(22),CLIDT(22),TCOOL(22),TC(22),
4 TCL(22),TEG(22),TCG(22),
25
5 SRISWEL(22),DELTA0(22),DPSWEL(22),DFSWEL(22),COLOGP(22),
6 VFGR(3,22),VFG(22),TVFGR(22),TOTFGR,VSG,VWV,VVFG,PLENP,PGR,EPV,
7 PETFG(22),VFGD(22),VFGD(2,22),VFGI(22),
8 STI(22),SZI(22),STRSI(22),STO(22),SZO(22),STRSO(22),
30
9 FLUENC(22),FLUNCI(22),BUI(22),BUI(22)
C
COMMON/PARCOM/
* HG1,HG2,HG3,HG4,A1,A2,A3,RX1,RGK,RG3,RG4,RG5,RG6,RG7,
* FYUSX,FYUSK,FYU5,FYU8X,FYURK,FYU8,FYPUX,FYPUK,FYPU,
* CSU235,CSU238,CSPU,EU235,EU238,EPU,ELGAMA,
35
* FG1,FG2,FG3,FG4,FG5,FG6,FG7,FG8,FR1,FR2,FR3,
* CK1,CK2,YE0,YES,YMODF0,YMODFS,FK1,FK2,FK3,FK0,FALFO,FALFT
C
C IF(IS.LT.0) GO TO 50
C CALCULATE METRIC TONS METAL
R02RM2=(R02-RM2)
C METRIC TONS METAL PER SEGMENT
RMTM=TMTM/SEGNM
RMTM6 = .8815 / (RMTM*.E6)
45
TOTFGR=0
TOTFG = 0.0
DO 40 J=1,NSEGM1
C
C CALCULATE THE NUMBER OF FISSION EVENTS BASED ON THE AVERAGE ENERGY
50
C RELEASED PER FISSION
FISONS=BUI(J) * RMTM * 5.392E23/EFBAR
C
C CALCULATE VOLUME OF FISSION GAS GENERATED
55
VFGI(J) = FISONS * (FU235*FYU5 + FU238*FYU8 + FPU*FYPU) *22.4E3
* /6.025E23
C
C FISGAS 2
C FISGAS 3
C FISGAS 4
C FISGAS 5
C FISGAS 6
C FISGAS 7
C FISGAS 8
C FISGAS 9
C FISGAS 10
C FISGAS 11
C FISGAS 12
C FISGAS 13
COM 2
COM 3
COM 4
COM 5
COM 6
COM 7
COM 8
COM 9
COM 10
COM 11
COM 12
COM 13
COM 14
COM 15
COM 16
COM 17
COM 18
COM 19
COM 20
COM 21
COM 22
COM 23
COM 24
COM 25
COM 26
COM 27
FISGAS 15
FISGAS 16
FISGAS 17
FISGAS 18
FISGAS 19
FISGAS 20
FISGAS 21
FISGAS 22
FISGAS 23
FISGAS 24
FISGAS 25
FISGAS 26
FISGAS 27
FISGAS 28
FISGAS 29
FISGAS 30
FISGAS 31
FISGAS 32
FISGAS 33

```

```

      VFG(J)=VFGD(J)+VFGI(J)
60 C
      C CALCULATE THE RELEASE FRACTIONS
      C
      PZ1=(RHX(J)**2-RM2)/RO2RM2
      PZ2=(REX(J)**2-RBX(J)**2)/RO2RM2
      PZ3=1.-PZ2-PZ1
65 PCT1=PZ1*Z1
      PCT2 = PZ2*Z2
      PCT3 = PZ3*Z3
      -----
70 C CORRELATED GAS RELEASE MODEL
      C
      IF(Z3.GT.0.0) GO TO 10
      BUDEP=BU(J)/FG1
      IF(RUCEP.LT.30.) O2=(1.-(1.-EXP(-BUDEP))*FG2/BUDEP)+(1.-FG7)*EG7
      IF(O2.LT.FG7)O2=FG7
75 O1=O2
      BUDEP=(RU(J)-FG3)/FG3
      O3=1.-(1.-EXP(-BUDEP))*FG6*EXP(-FG6*P(J))/BUDEP
      Z2=FG6*(BU(J)-FG3)
80 IF(Z2.LF.0.0) O3=1.-(1.-EXP(-BUDEP))*FG6*EXP(-FG6*P(J))*EXP(Z2)
      /BUDEP
      IF(RU(J).LT.FG3) O3=0.0
      IF(O3.LT.0.0) O3=0.0
      PCT1=O1+PZ1
      PCT2=O2+PZ2
85 PCT3=O3+PZ3
10 CONTINUE
      -----
90 C COMPUTE THE VOLUME OF FISSION GAS RELEASED FROM EACH SEGMENT THEN
      C SUM TO OBTAIN THE TOTAL VOLUME RELEASED
      C
      VFGR(1,J) = VFG(J)*PCT1
      VFGR(2,J) = VFG(J)*PCT2
      VFGR(3,J) = VFG(J)*PCT3
95 TVFGR(J)=VFGR(1,J)+VFGR(2,J)+VFGR(3,J)
      TOTFGR=TOTFGR+TVFGR(J)
      TOTFG = TOTFG + VFG(J)
      RETFG(J)=(VFG(J)-TVFGR(J))*RMTM6
      IF(I3.NE.1) GO TO 40
      VFGD(J)=VFG(J)
100 DO 30 L=1,3
      VFGD(L,J)=VFGR(L,J)
      CONTINUE
      C
      C COMPUTE THE PER CENT RELEASED
105 C
      IF(TOTFG.LE.0.0) PGR=0.0
      IF(TOTFG.LE.0.0) RETURN
      PGR = TOTFGR / TOTFG * 100.
      RETURN
110 50 DO 60 J=1,NSEG
      VFGD(J)=0.0
      DO 60 L=1,3
      VFGD(L,J)=0.0
      RETURN
60

```

```

FISGAS 34
FISGAS 35
FISGAS 36
FISGAS 37
FISGAS 38
FISGAS 39
FISGAS 40
FISGAS 41
FISGAS 42
FISGAS 43
FISGAS 44
FISGAS 45
FISGAS 46
FISGAS 47
FISGAS 48
FISGAS 49
FISGAS 50
FISGAS 51
FISGAS 52
FISGAS 53
FISGAS 54
FISGAS 55
FISGAS 56
FISGAS 57
FISGAS 58
FISGAS 59
FISGAS 60
FISGAS 61
FISGAS 62
FISGAS 63
FISGAS 64
FISGAS 65
FISGAS 66
FISGAS 67
FISGAS 68
FISGAS 69
FISGAS 70
FISGAS 71
FISGAS 72
FISGAS 73
FISGAS 74
FISGAS 75
FISGAS 76
FISGAS 77
FISGAS 78
FISGAS 79
FISGAS 80
FISGAS 81
FISGAS 82
FISGAS 83
FISGAS 84
FISGAS 85
FISGAS 86
FISGAS 87
FISGAS 88
FISGAS 89
FISGAS 90

```

88

```

SUBROUTINE CSINTR
C
C CSINTR COMPUTES COOLENT AND CLADDING TEMPERATURE DISTRIBUTIONS.
C VARIABLES DEFINED IN CSINTR
5 C TCOOL(I) -COOLENT TEMPERATURES,DEG C
C CLIDT(I) -CLADDING INNER BOUNDARY TEMPERATURE,DEG C
C CLODT(I) -CLADDING OUTER BOUNDARY TEMPERATURE,DEG C
C
C REAL KXFIL
10 COMMON/INPT/FLEN,E,FD,VOID,DP,CT,PM,CHF,CP,HF,HC,CK,TI,TO,TEMP2,
1 DENLO,DENHI,TD,DISM,PU,U235,SEGNUM,PBU,EFPD,STEPS,Z1,Z2,Z3,
3 CCPGM,F4,PPM,EPL,XFFIL,KXFIL,ALPHA0,ALPHAB,
3 YMOOD,YMOOS,PNU,PFLUX,TMS+C,XTEMP,ITAB1,ITAB2,ITAB3,ITAB4,
0TIINCR(10),PRATIO(10),CRATIO(10)
15 COMMON/RESX/RO,HM,RU2,RM2,RIDP,RB2,HC2,NSEG,DELR,INTM,NSEGM1,HIGHT,
1 FU235,FU23A,FPU,EFRAP,PIERM1,PI,PIT2,
2P(10),A(22),RFX(22),RRA(22),RCX(22),PRBAV(22),RESAV(22),RHLT(22),
3PROSD(22),
3P(22),MGP(22),RT(10,22),CLODT(22),CLIDT(22),TCOOL(22),TC(22),
20 DTCL(22),TEG(22),TCG(22),
5RISHEL(22),DELTA0(22),DPSHEL(22),DPSHEL(22),COLDGP(22),
6VFGH(3,22),VFG(22),TVFGR(22),TGTFCR,VSG,VNV,VVFG,PLENP,PCR,EPV,
7RETFG(22),VFGD(22),VFGHD(3,22),VFGI(22),
25 BSTI(22),SZI(22),STRSI(22),STO(22),SZO(22),STRSO(22),
9FLUENC(22),FLUNCI(22),BU(22),BUT(22)
C
C COMMON/PARCOM/
C * HG1,HG2,HG3,HG4,A1,A2,A3,RC1,RC2,RC3,RC4,RC5,RC6,RC7,
30 * FYUSX,FYUS,FYU5,FYUAX,FYUR,FYUR,FYPUX,FYPU,FYPU,
* CSU235,CSU23A,CSPU,EU235,EU23A,EPU,ELGAMA,
* FG1,FG2,FG3,FG4,FG5,FG6,FG7,FG8,FR1,FR2,FR3,
* CK1,CK2,YEC,YES,YMOGFO,YMOGFS,FK1,FK2,FK3,FKD,FALFD,FALFT
C
C
C
35 RIDP=DP-2.*CT
FORM THE INTEGRAL K DT TABLES
CALL SINPOT(DENHI,DENLO)
PERFORM INITIAL CALCULATIONS
40 C1=1./(HF+PI*CP)
IF(CK,DT,0.0) D2 = LOG(DP/RIDP)/(2.*PI*CK)
C
C LOOP THRU EACH SEGMENT - PERFORMING NECESSARY CALCULATIONS
C
45 DO 10 J=1,NSEG
P0=PH+PMP(0.0,E,FLEN)
DO 10 J=1,NSEG
C
C DETERMINE COOLANT TEMPERATURE ALONG THE PIN STEP 2
C IF(J,EG,NSEG) TCOOL(J)=TCOOL(J-1)+(P(J)*P(J-1)).25*HIGHT/(CHF*CP)
50 IF(J,EG,1) TCOOL(J)=TI+(P0+P(J)).25*HIGHT/(CHF*CP)
IF((J,GT,1).AND.(J,LT,NSEG)) TCOOL(J)=TCOOL(J-1)+(P(J)*P(J-1)).5
X*HIGHT/(CHF*CP)
C
C DETERMINE THE TEMPERATURE DROP FOR THE FILM AND CLADDING
C
55 DTF=P(J)*D1
C
C

```

```

CSINTR 2
CSINTR 3
CSINTR 4
CSINTR 5
CSINTR 6
CSINTR 7
CSINTR 8
CSINTR 9
COM 2
COM 3
COM 4
COM 5
COM 6
COM 7
COM 8
COM 9
COM 10
COM 11
COM 12
COM 13
COM 14
COM 15
COM 16
COM 17
COM 18
COM 19
COM 20
COM 21
COM 22
COM 23
COM 24
COM 25
COM 26
COM 27
CSINTR 11
CSINTR 12
CSINTR 13
CSINTR 14
CSINTR 15
CSINTR 16
CSINTR 17
CSINTR 18
CSINTR 19
CSINTR 20
CSINTR 21
CSINTR 22
CSINTR 23
CSINTR 24
CSINTR 25
CSINTR 26
CSINTR 27
CSINTR 28
CSINTR 29
CSINTR 30
CSINTR 31
CSINTR 32
CSINTR 33

```

SUBROUTINE CBINTR 74/74 OPI=1 TRACE

FTN 4,2+74351

03/12/75 12.00.53.

PAGE 2

```

C
C DETERMINE THE CLADDING ID AND OD TEMPERATURES
60 C CLODT(J) = TCOOL(J) + DTF
C
C IF (CK,LE,0.0) D2 = ALOG(DP/RIOP)/(2.*PI*(CK1+CK2+(CLODT(J)+P(J)
65 * +ALOG(DP/HIDP)/(4.*PI*(CK1+CK2+CLODT(J))))))
DTC=P(J)+D2
CLIDT(J) = CLODT(J) + DTC
10 CONTINUE
RETURN
END
```

```

CBINTR 34
CBINTR 35
CBINTR 36
CBINTR 37
CBINTR 38
CBINTR 39
CBINTR 40
CBINTR 41
CBINTR 42
CBINTR 43
CBINTR 44
CBINTR 45
```

		SUBROUTINE SPACE	SPACE	2
	C		SPACE	3
	C	ROUTINE TO WRITE PAGE HEADINGS	SPACE	4
	C		SPACE	5
5	C		SPACE	6
		COMMON/ALFA/ALFA(14),IFIRST	SPACE	7
		REAL KRFIL	COM	2
		COMMON/INPT/FLEN,E,FD,VOID,DP,CT,PH,CHF,CP,WF,WC,CK,TI,TB,TEMP2,	COM	3
		1 DENLO,DENHI,TD,DISM,PU,U235,SEGNM,PBU,EFPD,STEPS,Z1,Z2,Z3,	COM	4
10		3 CCPGM,FN,PPH,EPL,XEFIL,KRFIL,ALPHA0,ALPHAS,	COM	5
		3YMOCO,YMOOS,PNU,PFLUX,TMS=C,EXTEPP,ITAB1,ITAB2,ITAB3,ITAB4,	COM	6
		4IINC(10),PRATIO(10),CRATIO(10)	COM	7
		COMMON/RBX/RO,RM,PO2,RM2,RIDP,RR2,HC2,NSEG,DELR,TMTM,NSEGM1,MIGMT,	COM	8
		1 FU235,FU23A,FPU,EFBAP,PTERM1,P1,P1T2,	COM	9
15		2R(10),X(22),REX(22),HBA(22),RCA(22),MPSAV(22),RESAV(22),RMLT(22),	COM	10
		VMROSO(22),	COM	11
		3P(22),MCP(22),RT(10,22),CLODY(22),CLIDT(22),TCOOL(22),TC(22),	COM	12
		4TCL(22),TEG(22),TCG(22),	COM	13
		5RIS=EL(22),DELTA(22),DPS=EL(22),DFS=EL(22),COLOGP(22),	COM	14
20		AVFGR(3,22),VFG(22),VVFGR(22),TOTFGR,VSG,VMV,VDFG,PLEMP,PGA,EPV,	COM	15
		7PETFG(22),VFGC(22),VFGRC(3,22),VFGI(22),	COM	16
		8STI(22),SZI(22),STASI(22),STO(22),SZO(22),STRBO(22),	COM	17
		9FLUENC(22),FLUNCI(22),BU(22),BUI(22)	COM	18
	C		COM	19
25		COMMON/PARCOM/	COM	20
		* MG1,MG2,MG3,MG4,A1,A2,A3,RG1,RG2,RG3,RG4,RG5,RG6,RG7,	COM	21
		* FYUSX,FYUSK,FYUS,FYUAX,FYUAK,FYUA,FYPUX,FYPUK,FYPU,	COM	22
		* CSU235,CSU23A,CSPU,EU235,EU23A,EPU,ELGAMA,	COM	23
		* FG1,FG2,FG3,FG4,FG5,FG6,FG7,FG8,FR1,FR2,FR3,	COM	24
30		* CK1,CK2,YEO,YES,YMOODF,YMOODS,FK1,FK2,FK3,FK4,FALFO,FALFT	COM	25
			COM	26
			COM	27
	C		SPACE	9
	C		SPACE	10
	C	BRANCH ON FIRST TIME SWITCH	SPACE	11
35			SPACE	12
		IF(IFIRST) 10,20,20	SPACE	13
	C	NEW PROBLEM -- NOT THE FIRST	SPACE	14
40		READ(5,100) ALFA	SPACE	15
		IF(EOF(5)) 30,1	SPACE	16
	1	CONTINUE	SPACE	17
		NPAG=1	SPACE	18
		IFIRST=0	SPACE	19
		CALL DATE(TODAY)	SPACE	20
45		WRITE(6,110) ALFA,TODAY	SPACE	21
		RETURN	SPACE	22
	C		SPACE	23
	C	NORMAL ACTION -- WRITE PAGE HEADINGS	SPACE	24
50		NPAG=NPAG+1	SPACE	25
		WRITE(6,120) EFPD,PBU,ALFA,NPAG	SPACE	26
	C		SPACE	27
		RETURN	SPACE	28
55		WRITE(6,130)	SPACE	29
		STOP	SPACE	30
	C		SPACE	31
	100	FORMAT(13A6,A2)	SPACE	32
	110	FORMAT(32H1SIEK -- REF MEDL-TME 74-55 ,13A6,A2,6H DATE ,A10)	SPACE	33
	120	FORMAT(6H1 TIME ,F8.2,15H PEAK BURN UP ,F8.0,13A6,A2,7H PAGE,	SPACE	33

60		213)	SPACE	34
		FORMAT(24H1FINAL PROBLEM COMPLETED)	SPACE	35
		END	SPACE	36

```

SUBROUTINE STRESS
REAL KXFIL
COMMON/TAPY/FLN, E, FD, VOID, DP, CT, RM, CMF, CP, HF, MC, CK, TT, TB, TEMP2,
1 DENLC, DENMI, TD, DISM, PU, U235, SEGNUM, PRU, LEMD, STEPS, Z1, Z2, Z3,
3 CCPGM, FN, PPM, EPL, XFFIL, XRFIL, ALPHAO, ALPHAS,
3YMOD0, YMODS, PNU, PFLUX, TMSWC, EXTENP, ITAB1, ITAB2, ITAB3, ITAB4,
4TIINCR(10), PHATIO(10), CRAT10(10)
COMMON/RRX/RO, RM, R02, RM2, R1DP, RR2, RC2, NSEG, DELR, YTM, NSEGMI, MIGHT,
1 FU235, FU238, FPU, EFBAR, PTERM1, PI, PIT2,
10 2R(10), X(22), REX(22), RBX(22), RCX(22), RBSAV(22), RESAV(22), RMLT(22),
$RPOSG(22),
3P(22), HGP(22), RT(10, 22), CLODT(22), CL1DT(22), TCCOL(22), TC(22),
4TCL(22), TFG(22), TCG(22),
15 5RISHEL(22), DELTAD(22), DPSHEL(22), DFSHEL(22), COLOGP(22),
6VFGP(3, 22), VFG(22), TVFGR(22), TOTFGR, V8G, VMV, VORC, PLENP, PGR, EPV,
7RETFG(22), VFGD(22), VFGHD(3, 22), VFGI(22),
8STI(22), SZI(22), STHSI(22), STO(22), STHSO(22),
9FLUENC(22), FLUNCI(22), BU(22), RUI(22)
C
COMMON/PARCOM/
* MG1, MG2, MG3, MG4, A1, A2, A3, RG1, RG2, RG3, RC6, RC5, RC6, RC7,
* PYUR, FYUR, PYUR, FYUR, PYUR, FYUR, PYUR, FYUR, PYUR, FYUR,
* CSU235, CSU238, CPU, EU235, EU238, EPU, ELCAMA,
25 * FG1, FG2, FG3, FG4, FG5, FG6, FG7, FGR, FRI, FR2, FN3,
* CK1, CK2, YEO, YES, YMODFO, YMODFS, FK1, FK2, FK3, FKO, FALFO, FALFT
C
RPI=RIDP/2,
RP=RP/2,
NO 3050 J=1, NSEG
AVTEMP=(CLODT(J)+CL1DT(J))/2.0
YOUNG=YMOD0+YMODS+AVTEMP
TERM00=CLODT(J)-CL1DT(J)
TERM01=PLENP*(PP**2)+RPI**2
TERM02=(HP**2)+RPI**2
TERM03=YOUNG/(1.-PNU)
TERM04=(ALPHAO*20.+ALPHAS*2.+ALPHAS*CL1DT(J))+TERM00
TERM05=RP**2/TERM02-1./.(2.*ALOG(RP/RPI))
TERM06=ALPHAS*TERM00**2
TERM07=HP**2/TERM02*(1.-1./ALOG(RP/RPI))+1./.(2.*(ALOG(RP/RPI))**2)
TERM08=-ALPHAO*TERM00+ALPHAS*TERM00*(20.-CLODT(J)-CL1DT(J))
SRI=PLENP
SRG=EXTERP
C STRESS TANGENTIAL INSIDE SURFACE
45 STI(J)=(PLENP*(PP**2+RPI**2)-2.*EXTERP*PP**2)/TERM02+TERM03*(TERM0
10+TERM05+TERM06+TERM07)
C STRESS TANGENTIAL OUTSIDE SURFACE
STC(J)=(2.*PLENP*RPI**2-EXTERP*(HP**2+RPI**2))/TERM02+TERM03*(TERM
50 10+TERM05+TERM06+TERM07+TERM08)
C AXIAL STRESS INSIDE
STI(J)=.5*(SRI+STI(J)+TERM03*(TERM04+TERM05+TERM06+TERM07))
C AXIAL STRESS OUTSIDE
55 SZO(J)=.5*(SRG+STO(J)+TERM03*(TERM04+TERM05+TERM06+TERM07+TERM08))
C EFFECTIVE STRESS INSIDE
STHSI(J)=SQRT(.5*((SRI-STI(J))**2+(STI(J)-SZI(J))**2+(SZI(J)-SRI)
1*2))
C EFFECTIVE STRESS OUTSIDE

```

92

```

60 STPSO(J)=SQRT(.5*((SRG-STO(J))**2+(STO(J)-SZO(J))**2+(SZO(J)-SRG)
1*2))
3050 CONTINUE
RETURN
END

```

```

C      SUBROUTINE FDEL(15)
C      FDEL COMPUTES FUEL HOT AND COLD DIMENSIONAL CHANGES DUE TO
C      THERMAL EXPANSION AND IRRADIATION EFFECTS.
5      VARIABLES DEFINED IN FDEL
C      CFSNEL(1) -FUEL HOT SURFACE POSITION,CM
C      CCLOGP(1) -COLD FUEL-CLADDING GAP,CM
C      RFAL KRFIL
10     COMMON/INPT/FLEN,E,FJ,VOID,DP,CT,RH,CWF,CP,MF,FG,CK,T1,T6,TEPP2,
C      1 DENLG,BENHI,TD,DISN,PU,U235,SEGNUM,PRI,EPPO,STEPS,Z1,Z2,Z3,
C      3 CCFGM,PH,PP1,APL,AFIL,KRFIL,ALPHA1,ALPHAS,
15     1YPCFC,YMDS,PHU,FLUX,TMSPC,EXTEHP,ITAB1,ITAB2,ITAB3,ITAB4,
C      4T1,RCR(10),PHATIG(10),CRATIO(10)
C      COMMON/40X/HO,RH,RD2,RP2,RIDP,RC2,NSEG,DELR,TMTH,NSEGM1,HIGHT,
C      1 FU235,FU23A,FPU,EFBAF,PTENM1,PI,PIT2,
C      2R(10),X(22),FCX(22),RCX(22),RCX(22),ARSAY(22),RESAY(22),HMCT(22),
20     SHCSO(22),
C      3P(22),HGP(22),PT(10,22),CLODT(22),CLIDT(22),TCOOL(22),TC(22),
C      4TCL(22),TSG(22),TCG(22),
C      5RIS=EL(22),DELTA0(22),DPS=EL(22),DFS=EL(22),COLOGP(22),
C      6VFCR(3,22),VFG(22),TVFGR(22),TOTFGH,VSG,VHY,VDFG,PLENP,PCR,EPV,
25     7RETFG(22),VFGD(22),VFCRD(3,22),VFGI(22),
C      8STI(22),SZI(22),STHSI(22),STO(22),SZO(22),STRSD(22),
C      9FLUENC(22),FLUNCI(22),BU(22),BUI(22)
C      COMMON/PARCOM/
30     * MG1,MG2,MG3,MG4,A1,A2,A3,RC1,RC2,RC3,RC4,RC5,RC6,RC7,
C      * FYUSX,FYUSK,FYUS,FYUX,FYUK,FYUA,FYPUX,FYPUK,FYPU,
C      * CSU235,CSU23A,CSPU,EU235,EU238,EPU,ELGAMA,
C      * FG1,FG2,FG3,FG4,FG5,FG6,FG7,FG8,FR1,FR2,FR3,
C      * CR1,CR2,YEO,YES,YMCOFO,YMDOFS,FK1,FK2,FK3,FKO,FALFO,FALFT
35     COM
C      COM
C      COM
C      FUNCTIONAL FORM OF THE THERMAL EXPANSION
C      DD(T)=(FALFO+FALFT*T)+T
40     IF(15.LT.0) GO TO 40
C      -----
C      COMPUTE THE VOLUMETRIC AVERAGE FUEL THERMAL EXPANSION
C      -----
45     DD 30 J=1,NSEG
C      SUM3=0.0
C      ABLE=.5
C      DD 10 L=1,10
50     IF(P(L).LE.PCX(J)) GO TO 20
C      LL=L
C      SUM3=SUM3+R(L)*DELR*ABLE*DD(RT(L,J))
10     ABLE=1.
20     CONTINUE
C      SUM3=SUM3+.5*((R(LL)-RCX(J))*RCX(J)*DD(TC(J))+R(LL)*DD(RT(LL,J))
55     )-DELR*R(LL)*DD(RT(LL,J))
C      SUM3=2.*SUM3/(RO*2-RCX(J)*2)

```

```

FDEL 2
FDFLD 3
FDFLD 4
FDFLD 5
FDFLD 6
FDFLD 7
FDFLD 8
FDFLD 9
FDFLD 10
COM 2
COM 3
COM 4
COM 5
COM 6
COM 7
COM 8
COM 9
COM 10
COM 11
COM 12
COM 13
COM 14
COM 15
COM 16
COM 17
COM 18
COM 19
COM 20
COM 21
COM 22
COM 23
COM 24
COM 25
COM 26
COM 27
FDEL 12
FDFLD 13
FDFLD 14
FDFLD 15
FDFLD 16
FDFLD 17
FDFLD 18
FDFLD 19
FDFLD 20
FDFLD 21
FDFLD 22
FDFLD 23
FDFLD 24
FDFLD 25
FDFLD 26
FDFLD 27
FDFLD 28
FDFLD 29
FDFLD 30
FDFLD 31
FDFLD 32
FDFLD 33

```

		ABLE=1.+SUM3	FDELD	34
	C		FDELD	35
60	C	-----	FDELD	36
	C	FUEL HOT RADIUS AND FUEL-CLADDING COLD GAP	FDELD	37
	C	-----	FDELD	38
		K=J	FDELD	39
		FSHELL = FSFL(K,.5+RIDP-RU,IS)	FDELD	40
65		DPSHEL(J)=FSHELL*ABLE	FDELD	41
	C		FDELD	42
	C	LIMIT THE AMOUNT OF FUEL "DEFORMATION" TO THAT WHICH WILL CAUSE	FDELD	43
	C	A PRESSURE LARGE ENOUGH TO INITIATE YIELD.	FDELD	44
	C		FDELD	45
70	C	IF (DPSHEL(J).LT.RISHEL(J)) GO TO 100	FDELD	46
	C		FDELD	47
		YIELD=YFG+YFS*(CLICT(J)+.55.)	FDELD	48
		ECRY=CDG+YMODS*CLICT(J)	FDELD	49
		EF=Y+DDPG+YMODFS*RT(1,J)	FDELD	50
75		X1=CPSHEL(J)**2-PISHEL(J)**2	FDELD	51
		XR3=DPSHEL(J)**2+RISHEL(J)**2	FDELD	52
		XR2=CPSHEL(J)**2-RCX(J)**2	FDELD	53
	C		FDELD	54
		PMX=(YIELD*XR1+2.+DPSHEL(J)**2+PXTERP)/XR3-(PLENP+1013521.)	FDELD	55
80		FSHELM=(RISHEL(J)+(PMX*(PMU+XR3/XR1+((DPSHEL(J)**2-RCX(J)**2)/XR2	FDELD	56
		+PMU)*FC/EF)-2.*(EXTENP+DPSHEL(J)**2/XR1+PLENP*RCX(J)**2/EC/	FDELD	57
		*(XR2+EF))*RISHEL(J)/EC)	FDELD	58
	C		FDELD	59
		IF (FSHELL.GT.FSHELM/ABLE) DPSHEL(J)=FSHELM	FDELD	60
85		IF (FSHELL.GT.FSHELM/ABLE) FSHELL=FSHELM/ABLE	FDELD	61
	100	CONTINUE	FDELD	62
	C		FDELD	63
		COLDGP(J)=.5+RIDP*(1.0+0.01*DELTAD(J))-FSHELL	FDELD	64
	30	CONTINUE	FDELD	65
		RETURN	FDELD	66
90	40	CONTINUE	FDELD	67
	C		FDELD	68
	C	INITIALIZE THE GAP CLOSURE TO ZERO	FDELD	69
	C		FDELD	70
95		DO 50 J=1,NSEG	FDELD	71
		K=J	FDELD	72
		FSHELL=FSFL(K,0,0,IS)	FDELD	73
	50	CONTINUE	FDELD	74
		RETURN	FDELD	75
100		END	FDELD	76

```

SUBROUTINE PPRES
C
C PPRES COMPUTES THE PLENUM PRESSURE AT OPERATING TEMPERATURE BASED
C ON THE PERFECT GAS LAW.
C VARIABLES DEFINED IN PPRES
5 C VSG -VOLUME OF SORBED GAS,CC
C VNW -VOLUME OF WATER VAPOR,CC
C EPV -EFFECTIVE PLENUM VOLUME,CC
C VCFG -VOLUME OF FILL GAS,CC
10 C PLENP -PLENUM PRESSURE,DYNES/CM**2
C
COMMON/MCOM/A(5,3),GMOL(5)
REAL *RFFIL
COMMON/INPT/FLEN,E,FO,VOID,DP,CT,PM,CMF,CP,MP,MG,CK,TI,TD,TFMP2,
15 1 DENLO,DENHI,TO,DISH,PU,U235,SEGNUM,PBU,EFPD,STEPS,Z1,Z2,Z3,
3 CCRGM,FN,PPM,EPL,XEFIL,XFFIL,ALPHA0,ALPHAS,
3YMOD0,YMODS,PNU,PFLUX,TMSHC,EXTFRD,ITAB1,ITAB2,ITAB3,ITAB4,
4TTINCR(10),PRATIO(10),CRATIO(10)
COMMON/RBX/RO,RM,RQ2,RM2,RIDP,RR2,RC2,NSEG,DELR,TMTM,NSEGM1,NIGHT,
20 1 FU235,FU238,FPU,EFBR9,PIERM1,PI,PI2,
2R(10),X(22),REX(22),RFX(22),RCX(22),HRSV(22),RESV(22),RMLT(22),
3RROSG(22),
3P(22),MCP(22),HT(10,22),CLODT(22),CLIDT(22),TCOOL(22),TC(22),
4TCL(22),TEG(22),TCG(22),
25 5RIS=EL(22),DELTAQ(22),GPS=EL(22),DPS=EL(22),COLDGP(22),
6YFGR(3,22),VFG(22),TYFGR(22),TOTFGH,VSG,VNW,VCFG,PLENP,PCR,EPV,
7RTEFG(22),VFGD(22),VFGHD(3,22),VFGI(22),
8STI(22),SZI(22),STRSI(22),STO(22),SZO(22),STRSO(22),
9FLUENC(22),FLUNCI(22),BU(22),BUI(22)
30 C
COMMON/PARCOM/
* MG1,MG2,MG3,MG4,A1,A2,A3,RG1,RG2,RG3,RG4,RG5,MG6,RG7,
* FYUSX,FYUSK,FYUS,FYUX,FYUK,FYUA,FYPUX,FYPU,
* CSU235,CSU238,CSPJ,EU235,EU238,EPJ,ELGAMA,
35 * FG1,FG2,FG3,FG4,FG5,FG7,FR1,FR2,FR3,
* CK1,CK2,YEG,YES,YMCOFO,YMUDFS,FK1,FK2,FK3,FKD,FALFO,FALFT
C
C
C DATA FU,FPU,.75,.25/
40 C VOLUME OF SORBED GAS
VSG=CCRGM*TM1*Z,PIE-B
C VOLUME OF WATER VAPOR
VNW=PPM*INTM+.5*Z,2*FU/(10,+.381)
C EFFECTIVE PLENUM VOLUME
45 EPV=PI*RIDP*P*EPL/4,
C VOLUME OF FILL GAS
VCFG=EPV*(273./293.)
C PLENUM PRESSURE
PLENP=((TOTFGH+VSG+VNW+VCFG)*(TCOOL*(NSEG)+273.)/(273.*EPV
50 *))-1013521,
C MOLES OF HELIUM IN THE PLENUM AREA (HELIUM COMPOSITION OF THE FILL
GMOL(1)=VCFG*(1.-.01*(XFFIL+XFFIL))/2,24E4
C MOLES OF FISSION GAS IN THE PLENUM AREA
60 FGH=IGTFGH/2,24E4
C MOLES OF XENON (FISSION PRODUCT AND TAG GAS)
GMOL(2)=FGH*(FYUSX+FU235+FYUKX+FU238+FYPUX+FPU)/(FYUS+FU235
* +FYUK+FU238+FYPU+FPU) + VCFG*XEFIL*.01/2,24E4
SUBROUTINE PPRES 74/74 OPT=1 TRACE FTN 4,2+74351 03/12/75 12.05.16. PAGE 2
C MOLES OF KRYPTON (FISSION PRODUCT AND TAG GAS)
65 GMOL(3)=FGH*(FYUSX+FU235+FYUKX+FU238+FYPUX+FPU)/(FYUS+FU235
* +FYUK+FU238+FYPU+FPU) + VCFG*XFFIL*.01/2,24E4
C MOLES OF NITROGEN FROM THE OFF GAS
GMOL(4)=FN + VSG / 22,4E3
C MOLES OF ARGON FROM THE OFF GAS
GMOL(5)=.01*VSG/2,24E4
RETURN
END

```



```

      FUNCTION AFP(X,E,FLEN)
-----
C THIS FUNCTION PROVIDES SIFXII WITH AN AXIAL FLUX PROFILE FROM ONE OF
C THREE USER SELECTED ORIGINS DEPENDING ON THE INPUT VALUE FOR THE
C EXTRAPOLATION DISTANCE (E) AS FOLLOWS -----
5 C IF(E,LT,-1) USE TABLE LOOK UP USING ABS(E) VALUES WHICH ARE READ
C IF(E,LT,0,AND,E,GE,-1) USE A USER SPECIFIED EQUATION(SEE TABLE 30
C IF(E,EQ,0) USE INTERPOLATION FROM INPUTTED TABLES
C IF(E,GT,0) USE CHOPPED COSINE CURVE WITH EXTRAPOLATION DISTANCE E
-----
10 C
C COMMON/PROFC/NOFPD,DATA(X(21),DATAFP(21),DEBAR,DTFX,
+ READX(21),READFP(21),READEB(21),READTF(21),READP(21)
C
15 IF(E) 300,200,100
100 CONTINUE
-----
C FUNCTION FOR A CHOPPED COSINE CURVE WITH EXTRAPOLATION DISTANCE E
-----
20 XMLT=3.14159/(FLEN+2.*E)
XTERM=(X+E)*XMLT
AFP=5IN(XTERM)
RETURN
200 CONTINUE
-----
25 C FUNCTION FOR INTERPOLATION FROM INPUTTED TABLES
-----
NOFP=NOFPD
XX=X/FLEN
AFP=TERP(DATA,X,DATAFP,XX,NOFP)
RETURN
30 300 CONTINUE
IF(E,LT,-1.) GO TO 400
-----
35 C FUNCTION FOR USER SPECIFIED EQUATION
-----
AFP=.7246+.03236*X-.00095*X**2
RETURN
40 400 CONTINUE
-----
45 C FUNCTION FOR INTERPOLATION FROM A SET OF INPUTTED DATA
-----
NOFP=E+.001
XX=X/FLEN
AFP=TERP(READX,READFP,XX,NOFP)
RETURN
END

```

	FUNCTION EBR(X,E,FLFN)	AFP	49
		AFP	50
C	FUNCTION TO PROVIDE THE AXIAL DISTRIBUTION OF THE AVERAGE NEUTRON	AFP	51
C	ENERGY(MEV). SEE AFP FOR OPTIONS AND EXPLANATION OF VARIABLES.	AFP	52
C		AFP	53
5	COMMON/PROFC/NOFPD,DATA(21),DATAFP(21),DEBAR,DTFX,	AFP	54
	* READX(21),READFP(21),READER(21),READTF(21),READP(21)	AFP	55
		AFP	56
C	IF(E) 300,200,100	AFP	57
10	100 CONTINUE	AFP	58
	-----	AFP	59
C	FUNCTION FOR EBAN FOLLOWING A CHUPPED COSINE WITH EXTRAPOLATION DI	AFP	60
C	-----	AFP	61
	ERR=DEBAR	AFP	62
15	RETURN	AFP	63
	200 CONTINUE	AFP	64
	-----	AFP	65
C	FUNCTION FOR INTERPOLATION FROM DATA TABLES	AFP	66
C	-----	AFP	67
	ERR=DEBAR	AFP	68
20	RETURN	AFP	69
	300 CONTINUE	AFP	70
	IF(E,LT,-1.) GO TO 400	AFP	71
	-----	AFP	72
25	C FUNCTION FOR USE OF A USER SPECIFIED EQUATION	AFP	73
C	-----	AFP	74
	EBR=.63316+.057898*(X/2.54)+.0042851*(X/2.45)**2	AFP	75
	RETURN	AFP	76
	400 CONTINUE	AFP	77
	-----	AFP	78
30	C FUNCTION TO INTERPOLATE FROM A SET OF INPUTTED DATA	AFP	79
C	-----	AFP	80
	NOFPD=E*.001	AFP	81
	XX=X/FLFN	AFP	82
35	ERR=TERP(READX,READEB,XX,NOFPD)	AFP	83
	RETURN	AFP	84
	END	AFP	85

```

      FUNCTION TFX(Y,E,FLFN)                                AFP      86
C      AFP      87
C      FUNCTION TO PROVIDE THE AXIAL DISTRIBUTION OF THE RATIO OF NEUTRON
C      FLUX GREATER THAN .1MEV TO THE TOTAL NEUTRON FLUX. SEE AFP FOR
5      C      OPTIONS AND EXPLANATION OF VARIABLES.        AFP      88
C      AFP      89
C      COMMON/PHOFC/NOFPD,DATA(21),CATAFP(21),DEBAR,DTFX,
C      * READX(21),READFP(21),READER(21),READTF(21),READP(21)
C      AFP      90
C      AFP      91
C      AFP      92
C      AFP      93
10      C      IF(E) 300,200,100                             AFP      94
100      CONTINUE                                           AFP      95
C      -----AFP      96
C      FUNCTION FOR A CHOPPED COSINE WITH EXTRAPOLATION DISTANCE E
C      -----AFP      97
15      C      TFX=DTFX                                     AFP      98
C      RETURN                                             AFP      99
200      CONTINUE                                           AFP     100
C      -----AFP     101
C      FUNCTION FOR INTERPOLATION FROM A SET OF DATA VALUES
C      -----AFP     102
20      C      TFX=DTFX                                     AFP     103
C      RETURN                                             AFP     104
300      CONTINUE                                           AFP     105
C      IF(E.LT.-1.) GO TO 400                             AFP     106
25      C      -----AFP     107
C      FUNCTION FOR USER SPECIFIED EQUATION
C      -----AFP     108
C      TFX=DTFX                                     AFP     109
C      RETURN                                             AFP     110
30      C      400 CONTINUE                                 AFP     111
C      -----AFP     112
C      FUNCTION FOR INTERPOLATION FROM AN INPUTTED DATA SET
C      -----AFP     113
35      C      NOFP=-E+.001                                 AFP     114
C      XXXX/FLFN                                          AFP     115
C      TFX=TERP(READX,READTF,XX,NOFP)                    AFP     116
C      RETURN                                             AFP     117
C      END                                               AFP     118
C      AFP     119
C      AFP     120
C      AFP     121
C      AFP     122
C      AFP     123

```

	FUNCTION PMP(X,F,FLEN)	AFP	124
C		AFP	125
C	FUNCTION TO PROVIDE THE AXIAL POWER PROFILE. SEE AFP FOR OPTIONS	AFP	126
C	AND EXPLANATION OF VARIABLES	AFP	127
5	C	AFP	128
	COMMON/PROFC/NOFPD,DATA(21),DATAFP(21),DEBAR,OTFY,	AFP	129
	* READX(21),READFP(21),READER(21),READTF(21),READP(21)	AFP	130
C		AFP	131
	IF(E) 300,200,100	AFP	132
10	100 CONTINUE	AFP	133
C	-----	AFP	134
C	FUNCTION FOR A CHOPPED COSINE WITH EXTRAPOLATION DISTANCE E	AFP	135
C	-----	AFP	136
15	PMP= AFP(X,F,FLEN)	AFP	137
	RETURN	AFP	138
	200 CONTINUE	AFP	139
C	-----	AFP	140
C	FUNCTION FOR INTERPOLATION FROM A SET OF DATA VALUES	AFP	141
C	-----	AFP	142
20	PMP= AFP(X,F,FLEN)	AFP	143
	RETURN	AFP	144
	300 CONTINUE	AFP	145
	IF(E,LT,-1.) GO TO 400	AFP	146
C	-----	AFP	147
25	C	AFP	148
	FUNCTION FOR USER SPECIFIED EQUATION	AFP	149
C	-----	AFP	150
	PMP= AFP(X,E,FLEN)	AFP	151
	RETURN	AFP	152
30	400 CONTINUE	AFP	153
C	-----	AFP	154
C	FUNCTION FOR INTERPOLATION FROM A SET OF INPUTTED DATA	AFP	155
C	-----	AFP	156
35	NOFP=E+.001	AFP	157
	XX=X/FLEN	AFP	158
	PMP=TERP(READX,READP,XX,NOFP)	AFP	159
	RETURN	AFP	160
	END	AFP	160

60

```

PONET=0.872+2.98E-3*CLMTC
C=1.+EXP(0.1*(CLMTC-480.))
DELTA(J)=DELTA(J)+A*((FLUENC(J)*1.E-22)**PONET-((FLUENC(J)
* -FLUNCI(J))*1.E-22)**PONET) + .2 * (EXP(-1.12E-22*(FLUENC(J)
* -FLUNCI(J)))-EXP(-1.12E-22*(FLUENC(J))))/C

```

CDELD 34

CDELD 35

CDELD 36

CDELD 37

CDELD 38

CDELD 39

CDELD 40

CDELD 41

CDELD 42

CDELD 43

CDELD 44

CDELD 45

CDELD 46

CDELD 47

CDELD 48

CDELD 49

CDELD 50

CDELD 51

CDELD 52

CDELD 53

CDELD 54

CDELD 55

CDELD 56

CDELD 57

CDELD 58

CDELD 59

CDELD 60

CDELD 61

CDELD 62

CDELD 63

CDELD 64

CDELD 65

CDELD 66

CDELD 67

65

```

REFERENCE -- HEDL-TME 71-139

```

```

COEF3=10.

```

```

GO TO 4

```

70

```

COEF3=1.

```

```

A = .05*(CLMTC-600.)

```

```

R = .06*(CLMTC-460.)

```

```

      .09*(CLMTC-340.)

```

```

U = .05*(CLMTC-475.)

```

```

PONET=(2.+3.*EXP(D))/(1.+EXP(D))

```

```

COEF1=EXP(C)/(1.+EXP(C))

```

```

COEF2=COEF3*(.002/(1.+EXP(A))+.006/(1.+EXP(B)))

```

```

DELTA(J)=DELTA(J)+COEF1*COEF2/3.*((FLUENC(J)*1.E-22)**PONET-
1(FLUENC(J)-FLUNCI(J))*1.E-22)**PONET)

```

75

80

```

C
10 CONTINUE

```

```

C-----
C COMPUTE THE CLADDING DIMENSIONAL CHANGES

```

85

```

DPSWEL(J)=DP*.5*(1.+0.01*DELTA(J))*(1.+ALPHA*DELTA)

```

```

RISWEL(J)=RIDP/2.*(1.0+.01*DELTA(J))*(1.0+ALPHA*DELTA)

```

```

20 CONTINUE

```

```

C

```

90

```

RETURN

```

```

END

```

```

SUBROUTINE STRUCT(SLOTG,SMOTH,J,ISAV)
STRUCT 2
C STRUCT 3
C STRUCT 4
C STRUCT 5
5 C STRUCT 6
C STRUCT 7
C STRUCT 8
C STRUCT 9
C STRUCT 10
10 C STRUCT 11
C STRUCT 12
C STRUCT 13
C STRUCT 14
C STRUCT 15
15 C REAL XRFIL
COMMON/INPT/PLEN,E,F0,VOID,DP,CT,PH,CHF,CF,HF,HG,CK,TI,TB,TEMP2,
1 DENLG,DENHT,IO,DISH,PU,IR35,SEGNUM,PHU,EPPD,STEPS,Z1,Z2,Z3,
3 CCPGM,FN,PPH,EPL,XRFIL,XRFIL,ALPHA0,ALPHAS,
3 YMOD0,YMODS,PHU,PFLUX,TMSWC,EXTEPP,ITAB1,ITAB2,ITAB3,ITAB4,
20 4TIINCP(10),PRATIO(10),CRATIO(10)
COMMON/HHX/RO,RM,RC2,RC2,RC2,RC2,NSEG,DELW,TMTM,NSEGM1,NIGHT,
1 FU235,FU238,FPU,FRAR,PIEM1,PI,PI2,
24(10),X(22),PEX(22),HRA(22),HCA(22),HRSV(22),RESAV(22),HMLT(22),
4WROSG(22),
25 3P(22),MGP(22),HT(10,22),CLODT(22),CLIDT(22),TCOOL(22),TC(22),
4TCL(22),TEG(22),TCG(22),
SRIS=EL(22),DELTA(22),OPSWEL(22),DFSWEL(22),COLOGP(22),
6VFG(3,22),VFG(22),TVFG(22),TOTFCR,VSG,VWV,VDFG,PLENP,PCR,EPV,
7METFG(22),VFGD(22),VFGD(3,22),VFGI(22),
30 ESTI(22),SZI(22),STRS1(22),STO(22),SZO(22),STRSO(22),
9FLUENC(22),FLUNCI(22),BU(22),RUI(22)
C
COMMON/PARCOM/
35 * MG1,MG2,MG3,MG4,A1,A2,A3,RC1,RC2,RC3,RC4,RC5,RC6,RC7,
* FYUSX,FYUSK,FYUS,FYUX,FYUK,FYU,FYPUX,FYPU,
* CSU235,CSU238,CSPU,EU235,EU238,EPU,ELGAMA,
* FG1,FG2,FG3,FG4,FG5,FG6,FG7,FGA,FR1,FR2,FR3,
* CK1,CK2,YED,YES,YMOD0,YMODS,FK1,FK2,FK3,FKD,FALFO,FALFT
C
40 C
C ----- STRUCT 17
C EVALUATE THE COLUMNAR AND EQUIAXED GRAIN GROWTH TEMPERATURES STRUCT 18
C ----- STRUCT 19
C STRUCT 20
45 I=J
TCG(J)=FR1-FR2*P(J)
IF(TB.GT.0.0) TCG(J)=TB
TEG(J)=FH3
IF(TEMP2.GT.0.0) TEG(J)=TEMP2
C ----- STRUCT 25
50 C CALCULATE THE RADIUS OF THE EQUIAXED GRAIN GROWTH ZONE STRUCT 26
C ----- STRUCT 27
RE=RM
IF(TCL(J).LT.TEG(J)) GO TO 10
SLOTE=S(TEG(I),1) = SLOGT
RE=RFIND(SLOTE/PTERM1,RO,RM)
55 IF(RESAV(J).LE.RM) GO TO 20
10 IF(PE.LT.RESAV(J)) RE=RESAV(J)
STRUCT 33

```

	20	RE2=RE*RE	STRUCT	34
	C	-----	STRUCT	35
60	C	CALCULATE THE COLUMNAR GAIN GROWTH RADIUS	STRUCT	36
	C	-----	STRUCT	37
		RR=RM	STRUCT	38
		IF(TCL(J),LT.TCG(J)) GO TO 30	STRUCT	39
		SMOTH=S(TCG(I),1)	STRUCT	40
65		SLTOTR=SMOTP-SLOTO	STRUCT	41
		SMOTB=S(TCG(J),2)	STRUCT	42
		PM=PFIND(SLTOTB/PTERM1,RO,RM)	STRUCT	43
30		IF(RBSAV(J),LE.RM) GO TO 40	STRUCT	44
		IF(RB,GT,RBSAV(J)) GO TO 40	STRUCT	45
70		RR=RBSAV(J)	STRUCT	46
		XTB=1((.5+R02-.5*RB**2-RM2*ALOG(PD/RB))*PTERM1+SLOTO,1)	STRUCT	47
		SMOTB=S(XTB,2)	STRUCT	48
40		R52=R02*RB	STRUCT	49
		RC = SQRT(R52 - (DENLO/DENHI)*(R02-RM2))	STRUCT	50
75		R02 = PC**2	STRUCT	51
	C		STRUCT	52
	C	SAVE THE VALUES COMPUTED FOR RB,RC , AND RE	STRUCT	53
	C		STRUCT	54
		REX(1) = RE	STRUCT	55
80		RPX(1) = RB	STRUCT	56
		R0X(1) = RC	STRUCT	57
		IF(1SAV,NE,1) GO TO 50	STRUCT	58
		RPSAV(J)=RB	STRUCT	59
		R0SAV(J)=RE	STRUCT	60
65	50	RETURN	STRUCT	61
		END	STRUCT	62

```

PROGRAM SIEX(INPUT,OUTPUT,TAPE5=INPUT,TAPE6=OUTPUT)
C
C SIEX CONTROL ROUTINE--CONTROLS SUBROUTINE CALL SEQUENCE AND
C INCREMENTS TIME,BURNUP,AND FLUENCE.
5
C
C VARIABLES DEFINED IN SIEX-
C EFPO -ELAPSED TIME,EFFECTIVE FULL POWER DAYS
C PM -PEAK PIN POWER,WATTS/CM
C CHF -COOLANT MASS FLOW RATE,GM/SEC
10
C PBU -PEAK BURNUP,MWD/MTM
C BU(I) -SEGMENT BURNUP,MWD/MTM
C BUI(I) -SEGMENT BURNUP INCREMENT,MWD/MTM
C FLUENC(I) -SEGMENT FLUENCE,NEUTRONS/CM**2
C FLUENCI(I) -SEGMENT FLUENCE INCREMENT,NEUTRONS/CM**2
15
C P(I) -SEGMENT POWER,WATTS/CM
C
C REAL KXFIL
C COMMON/INPT/LEN,F,FD,VOID,DP,CT,PH,CHF,CP,WF,HG,CK,TI,TB,TEMP2,
20
C 1 DENLO,RFNMI,TD,DISM,FU,U235,SEGNUM,PRU,EFPO,STEPS,21,22,23,
C 3 CCPGM,PN,PPH,EPL,KXFIL,KKFIL,ALPHA0,ALPHAS,
C 3YMOD0,YMODS,PNU,PFLUX,TSMC,EXTERP,ITAB1,ITAB2,ITAB3,ITAB4,
C 4TIINC(10),PHATIU(10),CRATIO(10)
C COMMON/RHX/R0,RH,R02,RM2,RIDP,HR2,RC2,NSEG,DELR,TMTM,NSEGM1,NIGHT,
25
C 1 FU235,FU23A,FU1,FRAR,PTEAM1,PI,PI2,
C 2M(10),X(22),REX(22),HRX(22),HGX(22),HRSAV(22),RESAV(22),HMLT(22),
C 3HRUSO(22),
C 3U(22),HGP(22),HT(10,22),CLODT(22),CLIDT(22),TCOOL(22),TC(22),
C 4TCL(22),TFG(22),TCG(22),
30
C 4RISNEL(22),NFLTAD(22),CPSNEL(22),DFSNEL(22),COLDGP(22),
C 6VFGP(3,22),VFG(22),TVFGP(22),TOTFG4,VSG,VHV,VDFG,PLENP,PCR,EPV,
C 7HETFG(22),VFGD(22),VFGND(3,22),VFGI(22),
C 8STI(22),SZI(22),STHSI(22),SIG(22),SZO(22),STRSO(22),
C 9FLUENC(22),FLUENCI(22),BU(22),BUI(22)
C
C COMMON/PARCOM/
35
C * HG1,HG2,HG3,HG4,A1,A2,A3,RG1,PG2,FG3,PG4,RG5,FG6,FG7,
C * FYUSX,FYUS4,FYUS,FYUBX,FYU4X,FYUB,FYPUX,FYPU,
C * CSU235,CSU23A,CSPU,EU235,EU23B,EPL,ELGAMA,
40
C * FGI,FG2,FG3,FG4,FG5,FG6,FG7,FGA,FR1,FR2,FR3,
C * CK1,C=2,YE0,YE5,YMODEC,YMODES,FK1,FK2,FK3,FKD,FALFO,FALFT
C
C
C -----
C INPUT
C -----
45
C 10 CALL INPUT
C -----
C TIME INCREMENT CONTROL -- INCREMENT TIME,FLUENCE,AND BURNUP
C -----
50
C
C PBU=0.0
C BUPAT=0.0
C SECINC=0.0
C ISTEP=MAX1(ABS(STEPS)+1,,2.)
55
C DO 80 K=1,ISTEP
C IF (K.EQ.1) EFPO=0.0
C IF (K.EQ.1) GO TO 20
C
C SIEX 2
C SIEX 3
C SIEX 4
C SIEX 5
C SIEX 6
C SIEX 7
C SIEX 8
C SIEX 9
C SIEX 10
C SIEX 11
C SIEX 12
C SIEX 13
C SIEX 14
C SIEX 15
C SIEX 16
C SIEX 17
C COM 2
C COM 3
C COM 4
C COM 5
C COM 6
C COM 7
C COM 8
C COM 9
C COM 10
C COM 11
C COM 12
C COM 13
C COM 14
C COM 15
C COM 16
C COM 17
C COM 18
C COM 19
C COM 20
C COM 21
C COM 22
C COM 23
C COM 24
C COM 25
C COM 26
C COM 27
C SIEX 19
C SIEX 20
C SIEX 21
C SIEX 22
C SIEX 23
C SIEX 24
C SIEX 25
C SIEX 26
C SIEX 27
C SIEX 28
C SIEX 29
C SIEX 30
C SIEX 31
C SIEX 32
C SIEX 33

```

107

```

IF (K.GT.1) CMF=CMF*CRATIO(K-1)          SIEX 34
IF (K.GT.1) PM=PM*PRATIO(K-1)           SIEX 35
IF (K.GT.1) EFPD=EFPD+TIINCR(K-1)       SIEX 36
IF (K.GT.2) PM=PM/PRATIO(K-2)          SIEX 37
IF (K.GT.2) CMF=CMF/CRATIO(K-2)       SIEX 38
PPU = PPU*PM *FLEN*TIINCR(K-1) / (TMTM*1.E6) * (EFRAR / (EFBAR-ELGAMA)) SIEX 39
SECINC=TIINCR(K-1)*R.64E4              SIEX 40
BURAT = PM *FLEN *TIINCR(K-1) / (TMTM*1.E6) * (EFRAR / (EFBAR-ELGAMA)) SIEX 41
20 DO 30 J=1,NSEG                       SIEX 42
  BUI(J)=BURAT*PMP(X(J),E,FLEN)        SIEX 43
  IF(K.EQ.1) RUI(J)=60.                 SIEX 44
  IF(K.EQ.2) RUI(J)=RUI(J)-60.         SIEX 45
  BU(J)=BU(J)+RUI(J)                   SIEX 46
  FLUICI(J)=FFLUX*SECINC*AFP(X(J),E,FLEN) SIEX 47
  FLUENC(J)=FLUENC(J)+FLUICI(J)       SIEX 48
  P(J)=PMP*PMP(X(J),E,FLEN)           SIEX 49
30 CONTINUE                             SIEX 50
75 C ----- SIEX 51
C CLADDING TEMPERATURE CALCULATIONS SIEX 52
C ----- SIEX 53
C CALL CSINR SIEX 54
80 C ----- SIEX 55
C CLADDING DEFORMATIONS--THERMAL EXPANSION AND IRRADIATION SWELLING SIEX 56
C ----- SIEX 57
C CALL CDFLD SIEX 58
  IF (ITAB1.EQ.0) GO TO 40              SIEX 59
  IF (ITAB2.EQ.0) GO TO 40              SIEX 60
  IF (ITAB3.EQ.0) GO TO 40              SIEX 61
85 C ----- SIEX 62
C FUEL - CLADDING HEAT TRANSFER COEFFICIENT SIEX 63
C ----- SIEX 64
C CALL HCAP SIEX 65
90 C ----- SIEX 66
C FUEL TEMPERATURE CALCULATIONS SIEX 67
C ----- SIEX 68
40 CALL FSINTH (1) SIEX 69
  IF (ITAB2.EQ.0) GO TO 50              SIEX 70
95 C ----- SIEX 71
C FUEL DIMENSIONAL CHANGES SIEX 72
C ----- SIEX 73
C CALL FDFLD (1) SIEX 74
50 IF (ITAB1.EQ.0) GO TO 60              SIEX 75
100 C ----- SIEX 76
C FISSION GAS RELEASE AND FORMATION SIEX 77
C ----- SIEX 78
C CALL FISRAS (1) SIEX 79
105 C ----- SIEX 80
C PLENUM PRESSURE SIEX 81
C ----- SIEX 82
C CALL PPRES SIEX 83
60 IF (ITAB6.EQ.0) GO TO 70              SIEX 84
110 C ----- SIEX 85
C ELASTIC STRESS CALCULATIONS SIEX 86
C ----- SIEX 87
C CALL STRESS SIEX 88
70 IF(K.EQ.1.AND.ABS(STEPS).LE.0.0) GO TO 80 SIEX 89
  CALL OUTPUT SIEX 90

```

```

115 80 CONTINUE SIEX 91
  GO TO 10 SIEX 92
  END SIEX 93

```



```

C      CALCULATE COMPOSITION OF GAS PRESENT IN GAP                HGAP      34
C      -----                                                    HGAP      35
60  C      TMOL=0.0                                                HGAP      36
C      DO 20 I=1,NGAS                                             HGAP      37
C      20 TMOL=TMOL+GMOL(I)                                       HGAP      38
C      PAR=0.0                                                    HGAP      39
65  C      DO 30 I=1,NGAS                                         HGAP      40
C      BAR=BAR+GMOL(I)*GMW(I)                                     HGAP      41
C      30 GMOL(I)=GMOL(I)/TMOL                                    HGAP      42
C      BAR=PAR/TMOL                                              HGAP      43
C      TOT=0.0                                                  HGAP      44
70  C      -----                                                    HGAP      45
C      DETERMINE THERMAL EFFECTS OF FUEL AND CLAD SURFACES (JUMP DISTANCE) HGAP      46
C      -----                                                    HGAP      47
C      -----                                                    HGAP      48
C      -----                                                    HGAP      49
C      COEF = A1 * EXP(-(ALOG(NBAR)- A2)**2 /A3)                 HGAP      50
75  C      PRMX=PLENP*1013521.                                     HGAP      51
C      X11=(2.-COEF)/COEF                                        HGAP      52
C      -----                                                    HGAP      53
C      LOOP THRU ALL SEGMENTS TO COMPUTE A FUEL TO CLADDING HEAT TRANSFER HGAP      54
C      COEFFICIENT                                               HGAP      55
80  C      -----                                                    HGAP      56
C      DO 70 J=1,NSEG                                             HGAP      57
C      T=RT(1,J)                                                 HGAP      58
C      40 THAR=.5*(T+CLDIT(J))                                    HGAP      59
C      XMMIX=CONMIX(TBAR,GMOL)                                   HGAP      60
85  C      TBAR=TBAR+273.                                         HGAP      61
C      GVAL=X11*XMMIX*1373.*SORT(TBAR+NBAR)/PRMX                HGAP      62
C      -----                                                    HGAP      63
C      -----                                                    HGAP      64
C      DETERMINE HOT GAP WIDTH* IF CLOSURE OCCURS, CALCULATE INTERFACIAL HGAP      65
90  C      PRESSURE                                               HGAP      66
C      -----                                                    HGAP      67
C      -----                                                    HGAP      68
C      PGAP=PRMX                                                 HGAP      69
C      GAP=RISWEL(J)-DFSWEL(J)                                    HGAP      70
95  C      IF (GAP.GT.0.0) GO TO 50                               HGAP      71
C      -----                                                    HGAP      72
C      XR1=DPSWEL(J)**2-RISWEL(J)**2                             HGAP      73
C      XR2=(FSWEL(J)**2-HCN(J)**2)                               HGAP      74
C      YIELD=YFO+YFS*(CLDIT(J)-555.)                            HGAP      75
100 C      EC = YMODG +YMODS *CLDIT(J)                            HGAP      76
C      EF = YMODFO+YMODFS*T                                       HGAP      77
C      IF (GAP.LE.0.0) PGAP=PGAP+(EC*ABS(GAP)/RISWEL(J)+2.*(EXTERP HGAP      78
C      +DPSWEL(J)**2/XR1+PLENP*DFSWEL(J)**2*EC/(XR2*EF)))/(PNU HGAP      79
C      +(RISWEL(J)**2+DPSWEL(J)**2)/XR1+(DFSWEL(J)**2+PCX(J)**2)/XR2 HGAP      80
105 C      +PNU)*EC/EF)                                             HGAP      81
C      PMAX=(YIELD*XR1+2.*EXTERP*DPSWEL(J)**2)/(RISWEL(J)**2+DPSWEL(J)**2 HGAP      82
C      *)                                                         HGAP      83
C      IF (PGAP.GT.PMAX) PGAP=PMAX                                HGAP      84
110 C      -----                                                    HGAP      85
C      50 CONTINUE                                               HGAP      86
C      THE FACTORS HGX AND HGXX SIMULATE THE PLASTIC AND TIME DEPENDENT HGAP      87
C      DEFORMATION OF THE SURFACE ROUGHNESS. THESE FACTORS HAVE BEEN HGAP      88
C      USED FOR CORRELATION OF THE GAP CONDUCTANCE CALCULATION.  HGAP      89
C      HGX=EXP(HG2+PGAP)                                          HGAP      90

```

```

115      MGXX = EXP(-EPPD*MG0)
      IF(MGXX,LT,MGX) MGX=MGXX
      EPS=MG1+MGX + GVAL
C
C
120      C
C
C      -----
      OPEN GAP--CALCULATE GAP CONDUCTANCE BY CLASSICAL THEORY OF GAS MIX
      -----
C
      TCHK=T
      TKC=CLIDT(J)+273.
125      TKF=T+273.
      HRAD = 5.67E-12 * (TKF**2+TKC**2) * (TKF+TKC) / (1./EMF+
      * (DFS*EL(J)/HISWEL(J))+(1./EMC=1.))
      MGAS=XXMIX/(AMAX1(GAP,0.0)+EPS)
      HSE=0.0
130      IF(GAP.GT.0.0) GO TO 60
C
C
C      -----
      CLOSED GAP -- TEMPERATURE PROP ACROSS FUEL CLADDING INTERFACE IS
      CALCULATE BY A METHOD SIMILAR TO THAT PROPOSED BY ROSS AND STOUT
135      C
C
      XKF=(S(T+5.273)-S(T-5.273))/10.
      XKC=CX
      IF(CX,EQ,0.0) XKC=CX1+CX2+CLIDT(J)
      XKM=2.*XKF+XKC/(XKF+XKC)
140      HS=MG3*XKM*(PGAP-PRMX)/YIELD
      60      HGP(J)=MGAS + HS + HRAD
      T=CLIDT(J)+P(J)/(HGP(J)+6.2832*HISWEL(J))
      IF (ABS(T-TCHK).GT.10.) GO TO 40
      70      CONTINUE
145      C
C
C      -----
      CALCULATED GAP CONDUCTANCE CONVERGENCE CRITERIA
      -----
C
150      ITT3=ITT3+1
      IF (ITT3.GT.25) GO TO 90
      TGO=.FALSE.
      DO 80 J=1,NSER
      IF (ABS(HGP(J)-HSAV1(J))/HGP(J).GT.01) TGO=.TRUE.
155      FACT=.5
      IF (ITT3.GT.10) FACT=.1
      HGP(J)=HSAV1(J)+FACT*(HGP(J)-HSAV1(J))
      HSAV1(J)=HGP(J)
      80      CONTINUE
160      IF (TGO) GO TO 10
      RETURN
      90      WRITE(6,100)
      RETURN
165      C
      100 FORMAT (' HGAP HAS FAILED TO CONVERGE IN 25 ITERATIONS')
      END
      HGAP 91
      HGAP 92
      HGAP 93
      HGAP 94
      HGAP 95
      HGAP 96
      HGAP 97
      HGAP 98
      HGAP 99
      HGAP 100
      HGAP 101
      HGAP 102
      HGAP 103
      HGAP 104
      HGAP 105
      HGAP 106
      HGAP 107
      HGAP 108
      HGAP 109
      HGAP 110
      HGAP 111
      HGAP 112
      HGAP 113
      HGAP 114
      HGAP 115
      HGAP 116
      HGAP 117
      HGAP 118
      HGAP 119
      HGAP 120
      HGAP 121
      HGAP 122
      HGAP 123
      HGAP 124
      HGAP 125
      HGAP 126
      HGAP 127
      HGAP 128
      HGAP 129
      HGAP 130
      HGAP 131
      HGAP 132
      HGAP 133
      HGAP 134
      HGAP 135
      HGAP 136
      HGAP 137
      HGAP 138
      HGAP 139
      HGAP 140
      HGAP 141
      HGAP 142

```

	SUBROUTINE INPUT	INPUT	2
	DIMENSION C(51)	INPUT	3
	EQUIVALENCE (C(1),FLEN)	INPUT	4
	COMMON/PROFC/NOFPD,DATA(21),DATAFP(21),CEBAR,CTFX,	INPUT	5
5	* READX(21),READFP(21),READER(21),READTF(21),READP(21)	INPUT	6
	COMMON/ALFA/ALFA(14),IFIRST	INPUT	7
	REAL KRFIL	COM	2
	COMMON/INPT/FLEN,F,FD,VOID,DP,CT,PH,CMF,CP,MF,NG,CK,TI,T8,TEMP2,	COM	3
10	1 DENLO,DENHI,TD,DISH,PU,U235,SEGNUM,PRU,EFPD,STFPS,Z1,Z2,Z3,	COM	4
	3 CCPGM,PN,PPM,EPL,XEFIL,KRFIL,ALPHA0,ALPHAS,	COM	5
	3YMOD0,YMODS,PNU,PFLUX,TM5=C,EXTERP,ITAB1,ITAB2,ITAB3,ITAB4,	COM	6
	4TIINCR(10),PRATIO(10),CRATIO(10)	COM	7
	COMMON/RAX/RO,PM,R02,FM2,RIDP,RP2,MC2,ASLG,DELT,TM5,NSEGM1,MIGHT,	COM	8
	1 F0235,F023A,FPU,FKRAX,PTERM1,PI,P1T2,	COM	9
15	RK(10),X(22),REX(22),HRA(22),RCX(22),RSSAV(22),HESAV(22),HMLT(22),	COM	10
	TRPOSD(22),	COM	11
	3P(22),HQP(22),HT(10,22),CLCOT(22),CLIDT(22),TCCOL(22),TC(22),	COM	12
	4TCL(22),TEG(22),TCG(22),	COM	13
20	5HISHEL(22),DELTA0(22),DPSHEL(22),DPSHEL(22),COLOGP(22),	COM	14
	6VFG(3,22),VFG(22),TVFG(22),TOTFG,VSG,VWV,VDFG,PLENP,PCR,EPV,	COM	15
	7RETFG(22),VFGD(22),VFGD(3,??),VFG1(22),	COM	16
	8ST1(??),SZ1(22),STAS1(??),STO(22),STO(22),STASO(??),	COM	17
	9FLUENC(??),FLUNC1(22),BU(??),MU1(22)	COM	18
	COMMON/PARCON/	COM	19
25	* MG1,MG2,MG3,MG4,A1,A2,A3,RG1,RG2,PG3,NG4,PG5,RG6,NG7,	COM	20
	* FYUSX,FYUSK,FYUS,FYUX,FYUK,FYUA,FYPUX,FYPU,	COM	21
	* CSU235,CSU238,CSPU,EU235,EU238,EPU,ELGAMA,	COM	22
	* FGI,FG2,FG3,FG4,FG5,FG6,FG7,FG8,FR1,FR2,FR3,	COM	23
30	* CK1,CK2,YE0,YES,YMODFO,YMODFS,FK1,FK2,FK3,FKD,FALFO,FALFY	COM	24
	COMMON/	COM	25
	COMMON/	COM	26
	COMMON/	COM	27
	NAMELIST/INPT/FLEN,PM,DP,CT,CMF,CP,MF,NG,CK,TI,TR,TEMP2,DENLO,	INPUT	9
35	* DENHI,FD,SEGNUM,PRU,EFPD,TD,DISH,U235,PU,Z1,Z2,Z3,CCPGM,PPM,PN,	INPUT	10
	* EPL,ALPHA0,ALPHAS,YMOD0,YMODS,PNU,XEFIL,KRFIL,	INPUT	11
	* PFLUX,TM5=C,EXTERP,RM,E,VOID,STEPS,ITAB1,ITAB2,ITAB3,ITAB4	INPUT	12
	* TIINCR,PRATIO,CRATIO,READX,READFP,READER,READTF,READP	INPUT	13
	COMMON/	INPUT	14
40	IFIRST=-1	INPUT	15
	-----	INPUT	16
	MFINITIALIZ INPUT PARAMETERS TO PROPER UNITS FOR THE NEXT CASE	INPUT	17
	-----	INPUT	18
	EFPD=EFPDS	INPUT	19
	PRU=PRUS	INPUT	20
45	CALL SPAGE	INPUT	21
	FLEN=FLEN/2.54	INPUT	22
	IF(E.GT.0.0) E=E/2.54	INPUT	23
	FD=FD/2.54	INPUT	24
50	VOID=VOID/2.54	INPUT	25
	DP=DP/2.54	INPUT	26
	CT=CT/2.54	INPUT	27
	PN=PN/1000.*(2.54*12.)	INPUT	28
	CMF=CMF/.1260	INPUT	29
	CP=CP/4.186	INPUT	30
55	MF=MF/5.6761E-4	INPUT	31
	NG=NG/5.6761E-4	INPUT	32
	CK=CK/.0173	INPUT	33

60	TI=TI*1.8*32. EPL=EPL/2.54 ALPHA0=ALPHA0/1.8 ALPHAS=ALPHAS/3.24 YMODS=YMODS/(6.8947E4*1.8) YMOD0=YMOD0/6.8947E4 EXTEPP=EXTERP/6.8947E4	INPUT 34 INPUT 35 INPUT 36 INPUT 37 INPUT 38 INPUT 39 INPUT 40 INPUT 41
65	----- READ THE INPUT DATA ----- READ (5,JPT)	INPUT 42 INPUT 43 INPUT 44 INPUT 45 INPUT 46
70	----- LIST INPUT DATA WITH EXPLANATION OF SYMBOLS AND UNITS REQUIRED ----- CARDS TO ALLOW OLD DECKS WITH FLENAND E IN FT. TO BE RUN	INPUT 47 INPUT 48 INPUT 49 INPUT 50 INPUT 51
75	IF (FLEN.LT.4) FLEN=FLEN*12. IF (E.LT.2..AND.E.GT.0.0) E=E*12. WRITE (6,120)	INPUT 52 INPUT 53 INPUT 54 INPUT 55
80	WRITE (6,130) (C(I),I=1,9) WRITE (6,140) (C(I),I=10,18) WRITE (6,150) (C(I),I=19,26) WRITE (6,160) (C(I),I=27,35) WRITE (6,170) (C(I),I=36,42)	INPUT 56 INPUT 57 INPUT 58 INPUT 59 INPUT 60
85	DTAB1=ITAB1 DTAB2=ITAB2 DTAB3=ITAB3 DTAB4=ITAB4 WRITE (6,180) DTAB1,DTAB2,DTAB3,DTAB4	INPUT 61 INPUT 62 INPUT 63 INPUT 64 INPUT 65
90	----- CONVERSION OF INPUT VALUES TO CGS UNITS ----- EFPDS=EFPD PRUS=PRU FLEN=FLEN*2.54 IF (E.GT.0.0) E=E*2.54 FD=FD*2.54 VOID=VOID*2.54 DP=DP*2.54 CT=CT*2.54 PH=PH*(1000./(12.*2.54)) CMF=CMF*.1260 CP=CP*4.186 HF=HF*5.6761E-4 HG=HG*5.6761E-4 CK=CK*.0173 TI=(TI-32.)/1.8 EPL=EPL*2.54 ALPHA0=ALPHA0*1.8 ALPHAS=ALPHAS*3.24 YMODS=YMODS*(6.8947E4*1.8) YMOD0=YMOD0*6.8947E4 EXTERP=EXTERP*6.8947E4 NSEG=SEGNUM*1.	INPUT 66 INPUT 67 INPUT 68 INPUT 69 INPUT 70 INPUT 71 INPUT 72 INPUT 73 INPUT 74 INPUT 75 INPUT 76 INPUT 77 INPUT 78 INPUT 79 INPUT 80 INPUT 81 INPUT 82 INPUT 83 INPUT 84 INPUT 85 INPUT 86 INPUT 87 INPUT 88 INPUT 89 INPUT 90

112

```

115      NSEGM1=SEGNUM                                INPUT  91
      C-----
      C-----
      C COMPUTE SOME INPUT DEPENDENT QUANTITIES WHICH REMAIN CONSTANT
      C FOR THE ENTIRE CASE                            INPUT  94
      C-----
120      C-----
      C SEGMENT LENGTH                                INPUT  98
      C HEIGHT=FLEN/SEGNUM                            INPUT  100
125      C WEIGHT OF THE METAL IN THE FUEL COLUMN (MTM)  INPUT  102
      C  $TMTM = .8A15E-6 \cdot 25 \cdot \pi \cdot (FD \cdot 2 - VOID \cdot 2) \cdot FLEN \cdot DENLO \cdot TD \cdot (1 - DISM)$  INPUT  104
      C COMPUTE THE FRACTION OF FISSION EVENTS FROM EACH METAL
      C COMPONENT                                     INPUT  107
130      C  $FTOT = U235 \cdot CSU235 + (1 - U235 - PU) \cdot CSU238 + PU \cdot CSPU$  INPUT  109
      C  $FU235 = U235 \cdot CSU235 / FTOT$                 INPUT  110
135      C  $FU238 = (1 - U235 - PU) \cdot CSU238 / FTOT$  INPUT  111
      C  $FPU = PU \cdot CSPU / FTOT$                     INPUT  112
      C-----
      C COMPUTE THE AVERAGE ENERGY RELEASED FOR EACH FISSION EVENT
140      C  $EFBAR = EU235 \cdot FU235 + EU238 \cdot FU238 + EPU \cdot FPU$  INPUT  117
      C  $NSTEP = MAX(1, IARS(STEPS))$                  INPUT  119
      C IF (STEPS) 10,30,30                          INPUT  120
145      C IF STEPS IS NEGATIVE THE VALUES FOR TIME INCREMENTS, POWER RATIO
      C AND COOLANT FLOW RATE RATIO WILL BE USED IN THE CALCULATIONS AND
      C PRINTED IN THE OUTPUT                          INPUT  125
150      C0 CONTINUE                                  INPUT  126
      C WRITE (6,190)                                  INPUT  127
      C DAYS=0.0                                       INPUT  128
      C DO 20 I=1,NSTEP                                INPUT  129
      C DAYS=DAYS+TIINCR(I)                            INPUT  130
155      C  $POWER = PH \cdot PRATIO(I) \cdot 12.5 \cdot 10^{-3}$  INPUT  131
      C  $FLOWMFR = CRATIO(I) \cdot 126$                 INPUT  132
      C WRITE (6,200) I, TIINCR(I), DAYS, PRATIO(I), POWER, CRATIO(I), FLOWMFR INPUT  133
      C20 CONTINUE                                    INPUT  134
      C GO TO 60                                       INPUT  135
160      C30 CONTINUE                                  INPUT  136
      C-----
      C IF BURN UP INDICATED BY ZERO FOR EFPD, IS THE TIME STEP INDICATOR INPUT  138
      C THE APPROPRIATE FULL POWER DAYS TO ACHIEVE THIS BURN UP FOR THE PR INPUT  139
      C-----
165      C IF (EFPD,61,0.0) GO TO 40                    INPUT  141
      C  $EFPD = PRU + TMTM \cdot 1.6 / (PH \cdot FLEN) + (EFBAR - ELGAMA) / EFBAR$  INPUT  143
      C-----
170      C40 CONTINUE                                  INPUT  145
      C DO 50 I=1,NSTEP                                INPUT  146
      C  $TIINCR(I) = EFPD / FLOWMFR(NSTEP)$           INPUT  147

```

		PRATIO(I)=1.	INPUT	148
		CRATIO(I)=1.	INPUT	149
		50 CONTINUE	INPUT	150
175	C		INPUT	151
	C	IF F IS LESS THAN -1, VALUES FOR FLUX, AVERAGE NEUTRON ENERGY, AND	INPUT	152
	C	POWER PROFILES (AXIAL) ARE TO BE READ FROM INPUT--IN THAT EVENT	INPUT	153
	C	THE PROFILES WILL BE LISTED.	INPUT	154
	C		INPUT	155
180	60	CONTINUE	INPUT	156
		IF (E.GT.-1.) GO TO 80	INPUT	157
		NN=E+.0001	INPUT	158
		WRITE (6,100)	INPUT	159
		DO 70 J=1,NN	INPUT	160
185		XX=READX(J)	INPUT	161
		XFLUX=AFP(XX*FLEN,E,FLEN)	INPUT	162
		XERAF=ERF(XX*FLEN,E,FLEN)	INPUT	163
		XFM=TFX(XX*FLEN,E,FLEN)	INPUT	164
		XPM=FMP(XX*FLEN,E,FLEN)	INPUT	165
190	70	WRITE(6,110) XX,XFLUX,XEBAR,XPM,XPN	INPUT	166
	80	CONTINUE	INPUT	167
	C	-----	INPUT	168
	C	INITIALIZE THOSE VARIABLES ACCUMULATED DURING THE RUNNING OF A CAS	INPUT	169
	C	-----	INPUT	170
195		DO 90 J=1,NSEG	INPUT	171
		RESAV(J)=0.0	INPUT	172
		RBSAV(J)=0.0	INPUT	173
		DELTA(J)=0.0	INPUT	174
		BU(J)=0.0	INPUT	175
200		BU2(J)=0.0	INPUT	176
		FLUENC(J)=0.0	INPUT	177
		FLUENCI(J)=0.0	INPUT	178
		X(J)=NIGHT*(FLOAT(J)-.5)	INPUT	179
	90	MGP(J)=MG	INPUT	180
205		X(NSEG)=FLEN	INPUT	181
		CALL FCELD (-1)	INPUT	182
		CALL FISG4S (-1)	INPUT	183
		RETURN	INPUT	184
	C		INPUT	185
210	C		INPUT	186
	100	FORMAT(1M1,/,/,6X,85M--- AXIAL FLUX, NEUTRON ENERGY, AND POWER DIST	INPUT	187
		TRIBUTIONS USED FOR THIS ANALYSIS ---	INPUT	188
		+ 10X,99MAXIAL NEUTRON AVG NEUTRON RATIO OF FLU	INPUT	189
215		+ X LINEAR HEAT	INPUT	190
		+ 9X,100POSITION FLUX(TOTAL) ENERGY GT .1 MEV	INPUT	191
		+ TO HATING	INPUT	192
		+ 8X,100M(RELATIVE) (RELATIVE) (MEV) TOTAL FLU	INPUT	193
		+ X (RELATIVE)	INPUT	194
220		+ 8X,100M-----	INPUT	195
		-----	INPUT	196
	110	FORMAT(/,8X,F7.3,9X,F7.3,9X,F7.3,9X,F7.3,9X,F7.3)	INPUT	197
	120	FORMAT(41X,45M----- SIEX ANALYSIS -----	INPUT	198
		+ 37X,45MINPUT PARAMETERS USED FOR THIS ANALYSIS	INPUT	199
225		+ 21X,49H DESCRIPTION NAME ,25M	INPUT	200
		+ VALUE	INPUT	201
		+ 21X,49M ----- ,25M	INPUT	202
		----- /)	INPUT	203
130		FORMAT(INPUT	204

230	+ 21X,49HACTIVE FUEL COLUMN LENGTH	FLEN	,1PE17.4,	INPUT	205
	+ 4M IN, //			INPUT	206
	+ 17X,4H...			INPUT	207
	+ ,49H EXTRAPOLATION DISTANCE	E	,1PE17.4,	INPUT	208
	+ 4M IN, //			INPUT	209
235	+ 21X,49HFUEL DIAMETER	FD	,1PE17.4,	INPUT	210
	+ 4M IN, //			INPUT	211
	+ 21X,49HFUEL CENTRAL ANNULUS DIAMETER	VOID	,1PE17.4,	INPUT	212
	+ 4M IN, //			INPUT	213
	+ 21X,49HPIN DIAMETER	DP	,1PE17.4,	INPUT	214
	+ 4M IN, //			INPUT	215
240	+ 21X,49HCLADDING THICKNESS	CT	,1PE17.4,	INPUT	216
	+ 4M IN, //			INPUT	217
	+ 21X,49HMAXIMUM PIN HEATING RATE	PH	,1PE17.4,	INPUT	218
	+ 7M KW/FT, //			INPUT	219
245	+ 21X,49HCOOLANT MASS FLOW RATE	CMF	,1PE17.4,	INPUT	220
	+ 7M LB/HR, //			INPUT	221
	+ 21X,49HCOOLANT SPECIFIC HEAT	CP	,1PE17.4,	INPUT	222
	+ 14M BTU/LB-DEG F)			INPUT	223
140	FORMAT(INPUT	224
250	+ 21X,49HFILM COEFFICIENT	HF	,1PE17.4,	INPUT	225
	+ 20M BTU/FT**2-DEG F-HR, //			INPUT	226
	+ 21X,49HGAP COEFFICIENT	HG	,1PE17.4,	INPUT	227
	+ 20M BTU/FT**2-DEG F-HR, //			INPUT	228
	+ 17X,4H...			INPUT	229
255	+ ,49HCLADDING CONDUCTIVITY	CK	,1PE17.4,	INPUT	230
	+ 17M BTU/FT-DEG F-HR, //			INPUT	231
	+ 21X,49HINLET COOLANT TEMPERATURE	TI	,1PE17.4,	INPUT	232
	+ 7M DEG F, //			INPUT	233
	+ 17X,4H...			INPUT	234
260	+ ,49HTEMP, AT COLUMNAR (SINTERING) BOUNDARY	TR	,1PE17.4,	INPUT	235
	+ 7M DEG C, //			INPUT	236
	+ 17X,4H...			INPUT	237
	+ ,49HTEMP, AT EQUIAXED GRAIN BOUNDARY	TEMP2	,1PE17.4,	INPUT	238
	+ 7M DEG C, //			INPUT	239
265	+ 21X,49HFRACTION OF THEORETICAL DENSITY-UNSINTRO	DENLO	,1PE17.4/	INPUT	240
	+ 21X,49HFRACTION OF THEORETICAL DENSITY-SINTERED	DENHI	,1PE17.4/	INPUT	241
	+ 21X,49HFUEL THEORETICAL DENSITY	TD	,1PE17.4,	INPUT	242
	+ 7M GM/CC)			INPUT	243
150	FORMAT(INPUT	244
270	+ 17X,4H...			INPUT	245
	+ ,49HFRACTION OF FUEL VOLUME OCCUPIED BY DISH	DISH	,1PE17.4/	INPUT	246
	+ 17X,4H...			INPUT	247
	+ ,49HFRACTION OF METAL WHICH IS PU239 + PU241	PU	,1PE17.4/	INPUT	248
	+ 17X,4H...			INPUT	249
	+ ,49HFRACTION OF METAL WHICH IS URANIUM 235	U235	,1PE17.4/	INPUT	250
275	+ 21X,49HNUMBER OF AXIAL SEGMENTS	SEGNUM	,1PE17.4/	INPUT	251
	+ 17X,4H...			INPUT	252
	+ ,49HPEAK BURN UP	PBU	,1PE17.4,	INPUT	253
	+ 9M MWD/HR, //			INPUT	254
	+ 17X,4H...			INPUT	255
280	+ ,49HOPERATING TIME-EFFECTIVE FULL POWER DAYS	FFPD	,1PE17.4,	INPUT	256
	+ 6M DAYS, //			INPUT	257
	+ 17X,4H...			INPUT	258
	+ ,49HNUMBER OF CALCULATIONS/PRINTOUTS	STEPS	,1PE17.4/	INPUT	259
	+ 17X,4H...			INPUT	260
285	+ ,49HFISSION GAS RELEASE - COLUMNAR ZONE	Z1	,1PE17.4,	INPUT	261

```

160 * 10M FRACTION ) INPUT 262
    FCRMAT( INPUT 263
    * 17X,4M** INPUT 264
    * 40CFISSION GAS RELEASE - EQUIAXED ZONE 72 ,1PE17.4, INPUT 265
290 * 10M FRACTION ,// INPUT 266
    * 17X,4M** INPUT 267
    * 40CFISSION GAS RELEASE - UNRESTRUCTURED ZONE 23 ,1PE17.4, INPUT 268
    * 10M FRACTION ,// INPUT 269
    * 21X,40HSONBED GAS PER GRAM OF FUEL CCPGM ,1PE17.4, INPUT 270
295 * 7M CC/GM ,// INPUT 271
    * 17X,4M** INPUT 272
    * 40CFRACTION OF SORBED GAS WHICH IS NITROGEN FM ,1PE17.4, INPUT 273
    * 21X,40HPARTS PER MILLION WATER VAPOR FPM ,1PE17.4, INPUT 274
    * 21X,40EFFECTIVE PLENUM LENGTH EPL ,1PE17.4, INPUT 275
300 * 4M IN ,// INPUT 276
    * 21X,40PERCENT OF XENON IN THE FILL GAS XEFIL ,1PE17.4, INPUT 277
    * 21X,40PERCENT OF KRYPTON IN THE FILL GAS KRFIL ,1PE17.4, INPUT 278
    * 17X,4M** INPUT 279
    * 40HCOEF LINEAR EXPANSION - INTERCEPT ALPHA0 ,1PE17.4, INPUT 280
305 * 13M IN/IN-DEG F ) INPUT 281
    170 FORMAT( INPUT 282
    * 17X,4M** INPUT 283
    * 40HCOEF LINEAR EXPANSION - SLOPE ALPHAS ,1PE17.4, INPUT 284
310 * 14M IN/IN-(DEG F)**2 ,// INPUT 285
    * 17X,4M** INPUT 286
    * 40HYOUNGS MODULUS - INTERCEPT YMOD0 ,1PE17.4, INPUT 287
    * 10M LB/IN**2 ,// INPUT 288
    * 17X,4M** INPUT 289
    * 40HYOUNGS MODULUS - SLOPE YMODS ,1PE17.4, INPUT 290
315 * 14M LB/IN**2-DEG ,// INPUT 291
    * 17X,4M** INPUT 292
    * 40HPOISSONS RATIO PNU ,1PE17.4, INPUT 293
    * 21X,40HPEAK FLUX (ENERGY > .1 MEV) PFLUX ,1PE17.4, INPUT 294
    * 17M NEUT/CM**2-SEC ,// INPUT 295
320 * 21X,40HATERIAL (1=ANNEALED TYPE 308 SS TMSWC ,1PE17.4, INPUT 296
    * // INPUT 297
    * 21X,40H 2=ANNEALED TYPE 316 SS // INPUT 298
    * 21X,40H 3=20X CR TYPE 316 SS ) // INPUT 299
    * 21X,40HEXTERNAL PRESSURE EXTERP ,1PE17.4, INPUT 300
325 * 6M PSIG ) INPUT 301
    180 FORMAT( INPUT 302
    * 21X,40HFISSION GAS RELEASE/PLENUM PRESS. OPTION ITAB1 ,1PE17.4, INPUT 303
    * 21M 1=CALC 0=BYPASS ,// INPUT 304
    * 21X,40HPIN DELTA D/D OPTION ITAB2 ,1PE17.4, INPUT 305
330 * 21M 1=CALC 0=BYPASS ,// INPUT 306
    * 21X,40HHOT GAP COEFFICIENT OPTION ITAB3 ,1PE17.4, INPUT 307
    * 33M 1=CALC 0=NG FNCH ABOVE IS USED ,// INPUT 308
    * 21X,40HELASTIC STRESS OPTION ITAB4 ,1PE17.4, INPUT 309
    * 18M 1=CALC 0=BYPASS ,/// INPUT 310
335 * 17X,53M** INPUT OPTICNS OR CODE SUPPLIED VALUES CAN BE // INPUT 311
    * 21X,53MUSED. SEE THE USERS MANUAL IN MEDL-THE 74-55. ) INPUT 312
    190 FORMAT(1M, //105M --- SUMMARY TABULATION OF PIN POWER AND COOLANT INPUT 313
    * FLOW RATE VERSUS TIME INCREMENT FOR THIS ANALYSIS --- // INPUT 314
    * 33X,8MANALYSIS ,8X,8MTIMESTEP ,22X,8MTIMESTEP ,7X,8MTIMESTEP / INPUT 315
340 * 16X,12MELAPSED TIME ,4X,10MCUMULATIVE 5X,11MPOWER RATIO ,6X,8HTIM INPUT 316
    * 8STEP ,6X,10MFLOW RATIO ,6X,7MCOOLANT // INPUT 317
    * 16X,11M=1THIN STEP ,8X,4MTIME ,6X,11MTO INPUT PM ,7X,5MPOWER INPUT 318

```

SUBROUTINE INPUT

74/74 OPT=1 TRACE

PTN 4,2+74351

03/12/75 12.07.04.

PAGE 7

345

```
♦ .7X,12MTD INPUT CME ,5X,8MFLD-RATE // INPUT 319
♦ 4X,8MTIMESTEP ,5X,10MDAYS(EFPD) ,5X,10MDAYS(EFPD) ,7X,7M(RATIO) INPUT 320
♦ , 9X,5MKN/FT , 9X,7M(RATIO) , 9X,5MLR/MK // INPUT 321
♦ 4X,8M----- , 5X,10M----- ,5X,10M----- ,7X,8M----- INPUT 322
♦ ,7X,9M----- ,6X,9M----- ,7X,8M----- ) INPUT 323
200 FORMAT(/,6X,I3,9X,F7.1,8X,F7.1,10X,F5.2,11X,F5.2,9X,F5.2,9X,F6.0) INPUT 324
END INPUT 325
```

	BLOCK DATA	BLKDAT	2
C		BLKDAT	3
C		BLKDAT	4
	REAL KRFIL	COM	2
5	COMMON/IART/FLEN,E,FO,VOID,DP,CT,PM,CMF,CP,MP,NG,CA,II,TB,TEMP2,	COM	3
	1 DENLO,DENMI,TD,DISH,PU,U335,SEGNUM,PRU,EPFO,STEPS,Z1,Z2,Z3,	COM	4
	3 CCPGM,FN,PPM,EPL,XFFIL,KRFIL,ALPHAD,ALPHAS,	COM	5
	3YMODC,YMODS,PNU,PFLUX,IMSNC,EXTENP,ITAB1,ITAB2,ITAB3,ITAB4,	COM	6
	4TIINCR(10),PRATIO(10),CRATIO(10)	COM	7
10	COMMON/RHX/RO,RM,RO2,RM2,RIDP,HR2,RC2,NSEG,DELR,TMTM,NSEGMI,HIGHT,	COM	8
	1 FU235,FU234,PPU,EPBAR,PTERM1,PI,PI2,	COM	9
	2R(10),X(22),REX(22),RHX(22),RCX(22),HBSAV(22),HFSAV(22),RPLT(22),	COM	10
	SHROSS(22),	COM	11
	3P(22),MGP(22),HT(10,22),CLCO1(22),CLINT(22),ICOO1(22),TC(22),	COM	12
15	4TEL(22),TEG(22),TCG(22),	COM	13
	5PISHEL(22),DELTA0(22),DPSHEL(22),DFSHEL(22),COLDGP(22),	COM	14
	6VFGP(3,22),VFG(22),TVFGP(22),TGTFGP,VSG,V4V,V0FG,PLENP,PCR,EPV,	COM	15
	7REIFG(22),VFGD(22),VFGD(3,22),VFGI(22),	COM	16
	8STI(22),SZI(22),STRSI(22),STO(22),SZUI(22),STRSO(22),	COM	17
20	9FLUENC(22),FLUNCI(22),BU(22),RUI(22)	COM	18
C		COM	19
	COMMON/PARCOM/	COM	20
	* MG1,MG2,MG3,MG4,A1,A2,A3,RG1,RG2,RG3,RG4,RG5,RG6,RG7,	COM	21
25	* FYUSX,FYUSK,FYUS,FYUAX,FYUBX,FYUB,FYPUX,FYPUK,FYPU,	COM	22
	* CSU235,CSU234,CSPU,EU235,EU234,EPU,ELGAMA,	COM	23
	* FG1,FG2,FG3,FG4,FG5,FG6,FG7,FG8,FR1,FR2,FR3,	COM	24
	* CK1,CK2,YED,YES,YMODFO,YMODFS,FK1,FK2,FK3,FKD,FALPO,FALFT	COM	25
C		COM	26
C		COM	27
30	COMMON/TBLS2/ST(2,18),NT(2),TCENT(17),C(2,8)	BLKDAT	6
	COMMON/HCOM/A(5,3),GMCL(5),EMF,EMC	BLKDAT	7
C		BLKDAT	8
	COMMON/PROFC/WOPPO,DATAI(21),DATAFP(21),DEBAR,DYFK,	BLKDAT	9
35	* READY(21),READFP(21),READEB(21),READTF(21),READP(21)	BLKDAT	10
C		BLKDAT	11
C	-----	BLKDAT	12
C	PARAMETERS FOR THE CORRELATED MODELS	BLKDAT	13
C	-----	BLKDAT	14
C		BLKDAT	15
40	COEFFICIENTS IN THE FUEL-CLADDING GAP CORRELATION	BLKDAT	16
C		BLKDAT	17
	DATA RG1,RG2,RG3,RG4,RG5,RG6,RG7/3,RT92E-6,126.,-.522.,.395, -.01680	BLKDAT	18
	* .,600.,.11E-4/	BLKDAT	19
C		BLKDAT	20
45	COEFFICIENTS IN THE GAP CONDUCTANCE CORRELATION	BLKDAT	21
C		BLKDAT	22
	DATA MG1,MG2,MG3,MG4/1.1095E-3, -.3394E-9,13.7,3.E-3/	BLKDAT	23
C		BLKDAT	24
50	COEFFICIENTS USED FOR FUEL RESTRUCTURING	BLKDAT	25
C		BLKDAT	26
	DATA FH1,FR2,FR3/1886.,.4895,1570./	BLKDAT	27
C		BLKDAT	28
C	COEFFICIENTS FOR THE FISSION GAS RELEASE CORRELATION	BLKDAT	29
C		BLKDAT	30
55	DATA FG1,FG2,FG3,FG4,FG5,FG6,FG7,FG8/5890.,.86498,3515.,7.3451,	BLKDAT	31
	* 49170.,-.0002883,.0824,.001246/	BLKDAT	32
C		BLKDAT	33

118

	C	FISSION GAS YIELDS -- XENON.KRYPTON AND TOTAL FOR U235,U238	BLKDAT	34
	C	AND PU	BLKDAT	35
60	C		BLKDAT	36
	C	DATA FYU5X,FYU5K,FYU5,FYU8X,FYU8K,FYU8,FYU8X,FYU8K,FYU8,FYU8X,FYU8K,FYU8,FYU8X,FYU8K,FYU8,FYU8X,FYU8K	BLKDAT	37
	C	• .0482,.26569,.2135,.03085,.24435,.23314,.0238,.25694/	BLKDAT	38
	C		BLKDAT	39
65	C	FISSION CROSS SECTIONS AND DEPOSITED ENERGY PER FISSION FOR U235	BLKDAT	40
	C	U238 AND PLUTONIUM.	BLKDAT	41
	C		BLKDAT	42
	C	DATA CSU235,CSU238,CSPU/1.36,.0855,1.64/	BLKDAT	43
	C	DATA EU235,EU238,EPU/203,.201,.211./	BLKDAT	44
70	C	ENERGY WHICH IS LOST FROM THE FUEL PIN DUE TO GAMMA LOSS	BLKDAT	45
	C	DATA ELGAMA/9.2/	BLKDAT	46
	C		BLKDAT	47
	C	-----	BLKDAT	48
	C	MATERIAL PROPERTIES	BLKDAT	49
	C	-----	BLKDAT	50
75	C		BLKDAT	51
	C	COOLANT SPECIFIC HEAT	BLKDAT	52
	C		BLKDAT	53
	C	DATA CP/1.277/	BLKDAT	54
	C		BLKDAT	55
80	C	CLADDING THERMAL EXPANSION	BLKDAT	56
	C		BLKDAT	57
	C	DATA ALPHAO,ALPHAS/16.2E-6,3.7908E-9/	BLKDAT	58
	C		BLKDAT	59
85	C	CLADDING CONDUCTIVITY	BLKDAT	60
	C		BLKDAT	61
	C	DATA CK1,CK2/.13283,1.3E-4/	BLKDAT	62
	C		BLKDAT	63
	C	CLADDING ELASTIC PROPERTIES AND YIELD	BLKDAT	64
	C		BLKDAT	65
90	C	DATA YMOD0,YMODS,PNU/2.1236E12,-9.18E8,.3/	BLKDAT	66
	C	DATA YEO,YES/4.82E9,-1.078E7/	BLKDAT	67
	C		BLKDAT	68
	C	CLADDING EMISSIVITY	BLKDAT	69
	C		BLKDAT	70
95	C	DATA EMC/.90/	BLKDAT	71
	C		BLKDAT	72
	C	FUEL THERMAL EXPANSION	BLKDAT	73
	C		BLKDAT	74
	C	DATA FALFO,FALFT/.6578E-5,2.997E-9/	BLKDAT	75
100	C	FUEL CONDUCTIVITY	BLKDAT	76
	C		BLKDAT	77
	C	DATA FK0,FK1,FK2,FK3/ 1.133,.78,.02935,6.6E-13/	BLKDAT	78
	C		BLKDAT	79
105	C	FUEL ELASTIC PROPERTIES	BLKDAT	80
	C		BLKDAT	81
	C	DATA YMODFO,YMODFS/2.5E12,-4.455E8/	BLKDAT	82
	C		BLKDAT	83
	C	FUEL EMISSIVITY	BLKDAT	84
	C		BLKDAT	85
110	C	DATA EMF/.80/	BLKDAT	86
	C		BLKDAT	87
	C	GAS CONDUCTIVITIES	BLKDAT	88
	C	REF= P.E.LILEY,THERMAL CONDUCTIVITY OF 46 GASES AT ATMOSPHERE	BLKDAT	89
	C		BLKDAT	90

115	C	PRESSURE, PROC FOURTH SYMP ON THERMOPHYSICAL PROP. APRIL 1968	BLKDAT	91
	C		BLKDAT	92
		DATA (A(1,J),J=1,3)/1.3084E-3,3.6961E-6,-5.848E-10/	BLKDAT	93
		DATA (A(2,J),J=1,3)/5.7392E-5,1.4509E-7,-2.3279E-11/	BLKDAT	94
		DATA (A(3,J),J=1,3)/9.5598E-5,2.1357E-7,-3.5057E-11/	BLKDAT	95
120		DATA (A(4,J),J=1,3)/2.570E-4,5.651E-7,-7.336E-11/	BLKDAT	96
		DATA (A(5,J),J=1,3)/1.716E-4,4.122E-7,-8.015E-11/	BLKDAT	97
	C		BLKDAT	98
	C	ACCOMODATION COEFFICIENTS	BLKDAT	99
	C		BLKDAT	100
125		DATA A1,A2,A3/.8121,4.5167,7.7139/	BLKDAT	101
			BLKDAT	102
	C	CONSTANTS	BLKDAT	103
	C		BLKDAT	104
	C	DATA PI,PIT2/3.1415927,6.28318/	BLKDAT	105
130			BLKDAT	106
	C	TEMPERATURES USED IN THE TABLE LOOK UP PROCEEDURE FOR INTEGRAL KDT	BLKDAT	107
	C		BLKDAT	108
	C	DATA TCENT/0.0,100.,200.,400.,600.,800.,1000.,1200.,1400.,1600.,	BLKDAT	109
135		*1800.,2000.,2200.,2400.,2600.,2800.,3000./,NT/2*17/	BLKDAT	110
			BLKDAT	111
	C		BLKDAT	112
	C	-----	BLKDAT	113
	C	DATA FOR EBR-II AXIAL PROFILES (DEPLETED OXIDE BLANKET)	BLKDAT	114
	C	-----	BLKDAT	115
140			BLKDAT	116
	C	DATA DEBAR,DTFX,NOFPD/.88,.85,21/	BLKDAT	117
		DATA DATAX/0.0,.05,.1,.15,.2,.25,.3,.35,.4,.45,.5,.55,.6,.65,.7,	BLKDAT	118
		*.75,.8,.85,.9,.95,1./	BLKDAT	119
		DATA DATAFP/.781,.819,.857,.890,.924,.951,.970,.988,	BLKDAT	120
145		*.997,1.,.995,.987,.970,.948,.923,.894,.860,.827,.788,.762,.751/	BLKDAT	121
			BLKDAT	122
	C	-----	BLKDAT	123
	C	INITIAL VALUES OF CERTAIN INPUT PARAMETERS. THESE INITIAL VALUES	BLKDAT	124
	C	WILL BE OVERRIDDEN IF ANY INPUT IS ENCOUNTERED.	BLKDAT	125
150		-----	BLKDAT	126
	C		BLKDAT	127
		DATA DISH/0.01/	BLKDAT	128
		DATA PU,U235/.25,0.0/	BLKDAT	129
		DATA FN/.10/	BLKDAT	130
155	C		BLKDAT	131
		END	BLKDAT	132

	SUBROUTINE OUTPUT	OUTPUT	2
	COMMON/MCOM/A(5,3),GMOL(5)	OUTPUT	3
	REAL KRFIL	COM	2
	COMMON/IAPT/PLEN,E,FD,VOID,DP,CT,PH,CMF,CP,WF,MG,CK,TI,TB,TEMP2,	COM	3
5	1 DENLO,DENHI,TD,DISH,PU,U235,SEGNM,PRU,EPD,STEPS,Z1,Z2,Z3.	COM	4
	3 CCMGM,FH,PPM,EPL,KRFIL,KRFIL,ALPHA0,ALPHA3,	COM	5
	3YMODG,YMODS,PKU,PFLUX,IMSNC,LYTEP,ITAB1,ITAB2,ITAB3,ITAB4,	COM	6
	4TINCR(10),PRATIO(10),CRATIO(10)	COM	7
	COMMON/PEX/RO,RH,RC2,RM2,RIDP,RR2,RC2,ASEG,DELM,TMT,NSEGM1,NIGHT,	COM	8
10	1 FU235,FU23A,FPU,FFPAR,PTEAM,PI,PIT2,	COM	9
	2R(10),X(22),RFX(22),RFX(22),RCX(22),RBSAV(22),RESAV(22),RMLT(22),	COM	10
	RRROSG(22).	COM	11
	3P(22),MGP(22),RT(10,22),CLODT(22),CLIDT(22),TCOOL(22),TC(22),	COM	12
	4TCL(22),TEG(22),TCG(22),	COM	13
15	5RISNEL(22),DELTAD(22),DPS=EL(22),DFS=EL(22),COLDGP(22),	COM	14
	6VFG(3,22),VFG(22),TVFG(22),TOTFGS,VSG,VHV,VDFG,PLENP,PGR,EPV,	COM	15
	7RETFG(22),VFG(22),VFGRO(3,22),VFGI(22),	COM	16
	8STI(22),SZI(22),STHSI(22),STO(22),STO(22),STRSO(22),	COM	17
	9FLUENC(22),FLUNCI(22),BU(22),BU(22)	COM	18
20	C	COM	19
	COMMON/PARCOM/	COM	20
	* MG1,MG2,MG3,MG4,A1,A2,A3,RG1,RG2,RG3,RG4,RG5,RG6,RG7,	COM	21
	* FYUX,FYUSK,FYUS,FYUBX,FYUAK,FYUB,FYPUX,FYPUK,FYPU,	COM	22
	* CSU235,CSU238,CSPU,U235,U238,EPU,ELGAMA,	COM	23
25	* FGI,FG2,FG3,FG4,FG5,FG6,FG7,FG8,FR1,FR2,FR3,	COM	24
	* CA1,CM2,YEQ,YES,YMODFO,YMODFS,FK1,FK2,FK3,FAD,FALFO,FALFT	COM	25
	C	COM	26
	C	COM	27
30	C CALL SPACE	OUTPUT	5
	C	OUTPUT	6
	C CONVERT TO LB./IN**2	OUTPUT	7
	C	OUTPUT	8
	C PLENP=PLENP/6.8947E4	OUTPUT	9
	C EXTEP=EXTEP/6.8947E4	OUTPUT	10
35	C	OUTPUT	11
	C CONVERT TEMPERATURES TO DEG. F AND LENGTHS TO INCHES	OUTPUT	12
	C	OUTPUT	13
	C	OUTPUT	14
40	10 DO 10 J=1,10	OUTPUT	15
	R(J)=R(J)/2.54	OUTPUT	16
	DO 30 I=1,ASEG	OUTPUT	17
	TCOOL(I)=TCOOL(I)*1.8+32.	OUTPUT	18
	CLODT(I)=CLODT(I)*1.8+32.	OUTPUT	19
	TCL(I)=TCL(I)*1.8+32.	OUTPUT	20
	TC(I)=TC(I)*1.8+32.	OUTPUT	21
45	RFX(I)=PEX(I)/2.54	OUTPUT	22
	RCX(I)=RCX(I)/2.54	OUTPUT	23
	RFX(I)=RFX(I)/2.54	OUTPUT	24
	RMLT(I)=RMLT(I)/2.54	OUTPUT	25
	COLDGP(I)=COLDGP(I)/2.54	OUTPUT	26
50	DFS=EL(I)=DFS=EL(I)/2.54	OUTPUT	27
	DPS=EL(I)=DPS=EL(I)/2.54	OUTPUT	28
	RIS=EL(I)=RIS=EL(I)/2.54	OUTPUT	29
	X(I)=X(I)/2.54	OUTPUT	30
	P(I)=P(I)*12.*2.54/1000.	OUTPUT	31
55	MGP(I)=MGP(I)*1761.8	OUTPUT	32
	CLIDT(I)=CLIDT(I)*1.8+32.	OUTPUT	33
	RRROSG(I)=(R(I)/R(1))*2	OUTPUT	33

121

```

      DO 20 J=1,10
      RT(J,1)=RT(J,1)+1.8+32.
60      CONTINUE
      C-----
      C OUTPUT TABLE II -- BOUNDARY TEMPERATURES, POWER AND GAP CONDUCTANCE
      C-----
      WRITE(6,180)
      65      WRITE(A,100) (I,X(I),TCOOL(I),CLODT(I),CLIDT(I),RT(I,1),TC(I),
      * P(I),MGP(I),I=1,NSEGM1)
      WRITE(6,200) X(NSEG),TCOOL(NSEG),CLODT(NSEG),CLIDT(NSEG)
      * ,P(NSEG)
      CALL SPACE
      70      C-----
      C OUTPUT TABLE III -- FUEL STRUCTURE INFORMATION
      C-----
      WRITE(6,110)
      75      WRITE(6,120) (J,X(J),REX(J),TEG(J),RFX(J),TCG(J),RMLT(J),RCX(J),J
      * =1,NSEGM1)
      C-----
      C OUTPUT TABLE IV -- FUEL RADIAL TEMPERATURE DISTRIBUTIONS
      C-----
      C WRITE OUT RADII AND TEMPERATURES FOR EACH SEGMENT
      80      CALL SPACE
      WRITE(A,130)
      WRITE(6,140) (R(K),K=1,10)
      WRITE(6,150)
      WRITE(6,160) (PROSQ(K),K=1,10)
      85      WRITE(6,170) (J,X(J), (RT(K,J),K=1,10), J=1,NSEGM1)
      C-----
      C OUTPUT TABLE V -- FISSION GAS INFORMATION
      C-----
      90      IF (ITAB1.EQ.0) GO TO 40
      CALL SPACE
      WRITE(A,190)
      WRITE(6,200) (J,X(J),VFG(J), (VFGR(I,J),I=1,3),VFGR(J),RETFG(J),J
      * =1,NSEGM1)
      95      WRITE(6,210) PGH
      WRITE(6,220) TOTFGR,VSG,V=V,EPV,VOPG,PLENP,EXTERP
      WRITE(6,230) GMOL
      80 IF (ITAB2.EQ.0) GO TO 60
      CALL SPACE
      100      C-----
      C OUTPUT TABLE VI -- FUEL AND CLADDING GEOMETRY CHANGES
      C-----
      WRITE(6,240)
      DO 50 J=1,NSEGM1
      105      GAP=RISHWL(J)-DFSWEL(J)
      IF(GAP.LT.0.0) GAP=0.0
      WRITE(6,250) J,FLUFNC(J),DELTAD(J),OPSWEL(J),DFSWEL(J),RISHWL(J),
      * GAP,CLODGF(J)
      50 CONTINUE
      110      WRITE(6,250) NSEG,FLUENC(NSEG),DELTAD(NSEG),OPSWEL(NSEG)
      60 IF (ITAB4.EQ.0) GO TO 80
      CALL SPACE
      WRITE(6,260)
      DO 70 J=1,NSEG
      OUTPUT 34
      OUTPUT 35
      OUTPUT 36
      OUTPUT 37
      OUTPUT 38
      OUTPUT 39
      OUTPUT 40
      OUTPUT 41
      OUTPUT 42
      OUTPUT 43
      OUTPUT 44
      OUTPUT 45
      OUTPUT 46
      OUTPUT 47
      OUTPUT 48
      OUTPUT 49
      OUTPUT 50
      OUTPUT 51
      OUTPUT 52
      OUTPUT 53
      OUTPUT 54
      OUTPUT 55
      OUTPUT 56
      OUTPUT 57
      OUTPUT 58
      OUTPUT 59
      OUTPUT 60
      OUTPUT 61
      OUTPUT 62
      OUTPUT 63
      OUTPUT 64
      OUTPUT 65
      OUTPUT 66
      OUTPUT 67
      OUTPUT 68
      OUTPUT 69
      OUTPUT 70
      OUTPUT 71
      OUTPUT 72
      OUTPUT 73
      OUTPUT 74
      OUTPUT 75
      OUTPUT 76
      OUTPUT 77
      OUTPUT 78
      OUTPUT 79
      OUTPUT 80
      OUTPUT 81
      OUTPUT 82
      OUTPUT 83
      OUTPUT 84
      OUTPUT 85
      OUTPUT 86
      OUTPUT 87
      OUTPUT 88
      OUTPUT 89
      OUTPUT 90

```

```

115      STI(J)=STI(J)/6.8947E4      OUTPUT 91
        SZI(J)=SZI(J)/6.8947E4      OUTPUT 92
        STRSI(J)=STRSI(J)/6.8947E4  OUTPUT 93
        STO(J)=STO(J)/6.8947E4      OUTPUT 94
        SZO(J)=SZO(J)/6.8947E4      OUTPUT 95
120      STRSO(J)=STRSO(J)/6.8947E4  OUTPUT 96
        WRITE (6,270) J,STI(J),SZI(J),STRSI(J),STO(J),SZO(J),STRSO(J)  OUTPUT 97
        70 CONTINUE                  OUTPUT 98
        80 CONTINUE                  OUTPUT 99
C ----- OUTPUT 100
125      C CONVERT VARIABLES NEEDED FOR FUTURE TIME STEPS TO CGS UNITS  OUTPUT 101
        C ----- OUTPUT 102
        DO 90 J=1,NSEG               OUTPUT 103
        X(J)=X(J)*2.54              OUTPUT 104
        RAX(J)=RAX(J)*2.54          OUTPUT 105
130      WEX(J)=WEX(J)*2.54          OUTPUT 106
        90 WGP(J)=WGP(J)/1761.A     OUTPUT 107
        EXTERP=EXTERP*6.8947E4     OUTPUT 108
        RETURN                       OUTPUT 109
C ----- OUTPUT 110
135      100 FORMAT(/15,SX,F7.3,SX,F7.0,6X,F7.0,6X,F7.0,6X,F7.0,7X,F7.0,7X,F7.2  OUTPUT 111
        +,7X,F7.0)                  OUTPUT 112
        110 FORMAT(/1X,101M AXIAL DIST FROM FUEL EQUIAXED EQUIAXED FU OUTPUT 113
        +EL COLUMNAR COLUMNAR RADIUS OF FUEL CENTRAL // OUTPUT 114
        + 101M SEGMENT BOTTOM OF ZONE RADIUS, TEMP, ZONE RADIUS OUTPUT 115
140      +, TEMP, MELTED FUEL, VOID RADIUS, // OUTPUT 116
        + 101M NUMBER FUEL, IN INCHES DEG C INCHES OUTPUT 117
        + DEG C INCHES INCHES // OUTPUT 118
        + 101M ----- ) OUTPUT 119
        + ----- ) OUTPUT 120
145      120 FORMAT(/15,SX,F7.3,4X,F10.4,4X,F6.0,4X,F9.0,8X,F6.0,3X,F9.4,5X,F9.  OUTPUT 121
        + 4)                          OUTPUT 122
        130 FORMAT(140,A1X,15M RADIUS (INCHES) ) OUTPUT 123
140      140 FORMAT (21X,F7.3,9F10.3)  OUTPUT 124
        150 FORMAT(140,57X,24M(RADIUS/OUTER RADIUS)**2 ) OUTPUT 125
        160 FORMAT(4H0SEG,5X,4MINCH,45X,25HTEMPERATURE (FAHRENHEIT) ) OUTPUT 126
        170 FORMAT(/13,F10.3,F16.0,9F10.0) OUTPUT 127
        180 FORMAT(/114M AXIAL DIST FROM COOLANT CLAD OD CLAD OUTPUT 128
        + ID FUEL OUTER RESTRUC FUEL SEGMENT FUEL-CLAD // OUTPUT 129
        + 117M SEGMENT BOTTOM OF TEMP, TEMP, TEMP, S OUTPUT 130
155      +URF TEMP, INNER SURFACE POWER, GAP COEF, // OUTPUT 131
        + 117M NUMBER FUEL, IN DEG F DEG F DEG F OUTPUT 132
        + DEG F TEMP, DEG F KW/FT BTU/FT**2-MR-F // OUTPUT 133
        + 117M ----- ) OUTPUT 134
        + ----- ) OUTPUT 135
160      190 FORMAT(/100M AXIAL DIST FROM GENERATED - - VOLUME OF FISSION OUTPUT 136
        +N GAS RELEASED (CC) - - RETAINED // OUTPUT 137
        + 100M SEGMENT BOT FUEL FISSION GAS COLUMNAR EQUIAXED UN OUTPUT 138
        +REST. TOTAL FISSION GAS // OUTPUT 139
        + 100M NUMBER INCH CC AT STP ZONE ZONE Z0 OUTPUT 140
165      +NE // OUTPUT 141
        + 100M ----- ) OUTPUT 142
        + ----- ) OUTPUT 143
        200 FORMAT(/14,3X,F8.3,F12.2,F12.2,F12.2,F12.2,F14.3) OUTPUT 144
        210 FORMAT(////31M PERCENT FISSION GAS RELEASED ,F9.2) OUTPUT 145
170      220 FORMAT(/31M VOLUME OF RELEASED FISSION GAS ,F9.2, OUTPUT 146
        + 14M (CC AT STP) , OUTPUT 147

```

123

```

175 * //31M VOLUME OF BORRED GAS ,F9.2, OUTPUT 148
* 14M (CC AT STP) , OUTPUT 149
* //31M VOLUME OF WATER VAPOR ,F9.2, OUTPUT 150
* 14M (CC AT STP) , OUTPUT 151
* //31M EFFECTIVE PLENUM VOLUME ,F9.2, OUTPUT 152
* 19M (CC AT 20 DEG C) , OUTPUT 153
* //31M VOLUME OF FILL GAS ,F9.2, OUTPUT 154
* 14M (CC AT STP) , OUTPUT 155
180 * //31M PLENUM PRESSURE ,F9.0,8M (PSIG) , OUTPUT 156
* //31M EXTERNAL PRESSURE ,F9.0,8M (PSIG) ) OUTPUT 157
230 FORMAT(/31M MOLES OF HELIUM ,IPE11.2 OUTPUT 158
* //31M MOLES OF ZENON ,IPE11.2 OUTPUT 159
* //31M MOLES OF KRYPTON ,IPE11.2 OUTPUT 160
185 * //31M MOLES OF NITROGEN ,IPE11.2 OUTPUT 161
* //31M MOLES OF ARGON ,IPE11.2 ) OUTPUT 162
240 FORMAT(/100M AXIAL CLADDING CLAD OUTER FUEL OUT OUTPUT 163
* ER CLAD INNER FUEL-CLAD FUEL-CLAD ,/, OUTPUT 164
* 100M SEMENT FLUENCE SWELLING,% RADIUS,HOT RADIUS,HOT RADI OUTPUT 165
190 * US,HOT HOT GAP COLD GAP ,/, OUTPUT 166
* 100M NUMBER NEUT/CM**2 PERCENT INCH INCH INC OUTPUT 167
* M INCH INCH ,/, OUTPUT 168
* 100M --- OUTPUT 169
* --- ) OUTPUT 170
195 250 FORMAT(/13,2X,IPE12.3,2X,IPE12.3,0PF10.4,2F12.4,2F12.5) OUTPUT 171
260 FORMAT(/16X,2J)--- INSIDE STRESS --- ,15X,24M--- OUTSIDE STRES OUTPUT 172
* S --- // OUTPUT 173
* 85M SEG TANGENTIAL AXIAL EFFECTIVE TANGENTIAL OUTPUT 174
* AXIAL EFFECTIVE ,/, OUTPUT 175
200 * 85M --- OUTPUT 176
* --- ) OUTPUT 177
270 FORMAT(/,I4,F13.0,F13.0,F11.0,3X,F12.0,F13.0,F11.0) OUTPUT 178
280 FORMAT(/,5M TOP,,5X,F7.3,5X,0PF7.0,6X,F7.0,6X,F7.0,3X,F7.2) OUTPUT 179
END OUTPUT 180

```