

**Proceedings of First Semiannual
EPRI Solar Program Review
Meeting and Workshop**

EPRI

EPRI ER-283-SR
Special Report
Volume I
March 8-12, 1976

MASTER

Prepared by
Altas Corporation
Santa Clara, California

ELECTRIC POWER RESEARCH INSTITUTE

DISCLAIMER

This report was prepared as an account of work sponsored by an agency of the United States Government. Neither the United States Government nor any agency thereof, nor any of their employees, makes any warranty, express or implied, or assumes any legal liability or responsibility for the accuracy, completeness, or usefulness of any information, apparatus, product, or process disclosed, or represents that its use would not infringe privately owned rights. Reference herein to any specific commercial product, process, or service by trade name, trademark, manufacturer, or otherwise does not necessarily constitute or imply its endorsement, recommendation, or favoring by the United States Government or any agency thereof. The views and opinions of authors expressed herein do not necessarily state or reflect those of the United States Government or any agency thereof.

DISCLAIMER

Portions of this document may be illegible in electronic image products. Images are produced from the best available original document.

**PROCEEDINGS of
First Semiannual EPRI Solar Program
Review Meeting and Workshop**

EPRI ER-283-SR

Special Report

**VOLUME I:
SOLAR HEATING AND COOLING
OF BUILDINGS**

San Diego, California

March 8-12, 1976

Edited by

**Francis de Winter
Altas Corporation
Santa Clara, California**

Prepared for

**Electric Power Research Institute
3412 Hillview Avenue
Palo Alto, California 94304**

**Program Manager
Piet Bos**

MASTER

EP

NOTICE

This report was prepared by the Altas Corporation as an account of work sponsored by the Electric Power Research Institute, Inc. (EPRI). Neither EPRI, members of EPRI, the Altas Corporation, nor any person acting on behalf of either: (a) makes any warranty or representation, express or implied, with respect to the accuracy, completeness, or usefulness of the information contained in this report, or that the use of any information, apparatus, method, or process disclosed in this report may not infringe privately owned rights; or (b) assumes any liabilities with respect to the use of, or for damages resulting from the use of, any information, apparatus, method, or process disclosed in this report.

TABLE OF CONTENTS
VOLUME I: SOLAR HEATING AND COOLING OF BUILDINGS

Sec. 1	INTRODUCTION.....	1-1
2	OPENING STATEMENT AT THE MEETING, BY Piet B. Bos.....	2-1
3	ERDA/DSE PROGRAM OVERVIEW: A Brief Description of the ERDA Solar Program Covering Current and Projected Activities in the Thermal Applications and Electric Applications, by James E. Rannels of ERDA.....	3-i
4	EPRI Contract RP553 Solar Heating and Cooling of Buildings: Requirements Definition and Impact Analysis, by Walt Melton of the Aerospace Corporation.....	4-i
5	EPRI Contract RP549-1 Individual Load Center -Solar Heating and Cooling Residential Project, by Dan Nathanson of Arthur D. Little, Inc.....	5-i
6	EPRI Contract RP544-1 An Investigation of Methods to Improve Heat Pump Performance and Reliability in a Northern Climate, by Herbert S. Kirschbaum of Westinghouse.....	6-i
7	EPRI Contract RP550-1 Solar Materials and Components Test Program, by Sheldon L. Levy of the Black & Veatch Consulting Engineers Power Division.....	7-i
8	EPRI Contract RP552-1 Solar Data Verification Project, by Alexander J. Houghton of Science Applications, Inc.....	8-i

Blank Page

TABLE OF CONTENTS
VOLUME II: SOLAR ELECTRIC POWER

Sec. 9	EPRI Contract RP551-1 Environmental Assessment of Solar Energy Power Plants, by Ronald L. Wood of the Black & Veatch Consulting Engineers Power Division.....	9-i
10	EPRI Contract RP551-2 Environmental Assessment of Solar Energy Power Plants, by Keshavan Nair of Woodward Clyde Consultants.....	10-i
11	EPRI Contract RP648 Requirements Definition and Impact Analysis of Solar Thermal Power Plants, by John T. Day of Westinghouse Electric Corporation Advanced Systems Technology Division.....	11-i
12	EPRI Contract RP377-1 Closed Cycle, High Temperature Central Receiver Concept for Solar Electric Power, by John R. Gintz of Boeing Engineering and Construction.....	12-i
13	EPRI Contract RP475-1 Open Cycle Gas Turbine Solar Electric System, by J.C. Grosskreutz of Black & Veatch Consulting Engineers Power Division.....	13-i
14	EPRI Contract RP739 Preliminary System Analysis of a Solar Power Central Station, by John L. Russell of General Atomic Co.....	14-i
15	EPRI Contract TPS-75-611 A Study of the Impact on Margin Requirements for Utility Systems of Large-Scale Utilization of Solar Power Plants, by George C. McKoy of the Aerospace Corporation.....	15-i
16	EPRI Contract RP651-1 Requirements Assessment of Photovoltaic Electric Power Systems, by W.D. Marsh of the General Electric Company Systems and Technology Division.....	16-i
17	EPRI Contract RP790-1 Thermophotovoltaic Project, by Ronald N. Bracewell of Stanford University.....	17-i

SUMMARY

The Electric Power Research Institute has funded an extensive program in solar energy R&D in order to define and develop those solar energy systems which yield the lowest cost, when integrated with utility networks, and to define the impact of solar energy system interactions with these networks. During the week of March 8-12, 1976, EPRI sponsored the first semiannual Program Review Meeting and Workshop in San Diego, California.

The present volumes constitute the proceedings of this meeting. Volume I is concerned primarily with solar heating and cooling. Volume I also includes a short overview of the ERDA program, and reports on the EPRI - sponsored work in insolation data evaluation and in materials and components testing. Volume II is concerned primarily with solar electric power and environmental impact of various solar plants.

INTRODUCTION

Many if not most solar energy utilization systems being considered at present will have to be connected to the utilities in some way. If solar heating and cooling systems of buildings fail to provide comfort due to extended bad weather, it may be most convenient to use the utilities as a backup power supply. If solar energy is used to produce electrical power, the electric network of the electric power utilities is almost certain to be used to distribute solar electric power produced in central power plants, or as a backup for dispersed local solar electric power systems. Diurnal and seasonal fluctuations in loads have historically been one of the most troublesome problems facing the electric utilities. One can not invest in a power plant of maximum efficiency if the very high capital cost associated with such a plant is to be useful only for satisfying power peaks existing a small fraction of the time. The most efficient power plants are also not generally suited for peaking service, since they take a long time to bring on line. The plants used for peaking are (except for hydro-electric plants) cheaper to buy but significantly more expensive to operate.

If solar energy systems are designed and implemented in such a way as to reduce the power peaks in the utility network, they will save more fossil fuel, and be more effective in reducing energy costs. If on the other hand solar energy systems are designed in such a way as to reduce the base loads in an electric power network, but to impose enormous power peak requirements in times of some weather conditions, it is quite clear these systems would produce many problems. There is a great incentive to encourage solar energy systems which are preferred in this regard, and to develop a full awareness of the harmful implications of those systems which are not preferred. We are faced with the energy problems of society: if costs are imposed through bad design someone will have to pay them.

The Electric Power Research Institute has a significant research program in solar energy. The objectives of the program are as suggested above: to define and develop those solar energy systems which seem most promising when examined in the

light of total economics, and to identify those solar energy systems which will impose serious economic problems. Work is being sponsored both in the Solar Heating and Cooling of Buildings (SHACOB), and in solar electric power production. It should be noted that many regional questions are involved in this program. The climate, the utility customers, and the time schedule and magnitude of power consumption fluctuations all vary from place to place.

The U.S. Government (primarily the Energy Research & Development Administration) has a major program in solar energy R&D aimed at a somewhat different set of questions. There has been a continuing effort to coordinate the EPRI program with the work being sponsored by ERDA.

The EPRI Solar Energy Program started approximately one year ago, with many projects only recently funded. During the week of March 8-12, 1976, EPRI sponsored a review meeting and workshop for the Solar Energy Program in San Diego. This was the first semiannual meeting, aimed at reviewing current work, and planning future work, and at allowing all the contractors to gain familiarity with and contribute to the overall EPRI program. The following meeting will be in Falmouth, Massachusetts, October 6, 7, and 8, 1976, and the following will probably be in Monterey, California, in mid-March, 1976.

The contractors were asked to supply camera-ready copy of their visual aid material, and an accompanying discussion suitable for preparing a set of proceedings of the "landscape" type.

Since a true "landscape" format would have led to a page count of well over 800 pages for the two volumes, the material was edited somewhat, and was assembled in a more compact format, and photoreduced prior to printing. The coordination of the meeting and the editing of the proceedings was done under contract by the Altas Corporation.

Questions regarding the work can be directed to the individual authors or to EPRI. Questions regarding future meetings should be directed to EPRI.

OPENING STATEMENT AT THE MEETING, By Piet B. Bos, Manager of the Solar Energy Program of EPRI

Good Morning.

It is a pleasure for me to welcome you to the first semi-annual EPRI Solar Program Review Meeting and Workshop.

For those of you not familiar with the Electric Power Research Institute, this Institute was established by the electric utility industry in January, 1973, for the purpose of doing electric energy research and development under the sponsorship of the nation's utility industry. Its goal is to develop a broad, coordinated advanced technology program for improving electric power production, transmission, distribution and utilization in an environmentally acceptable manner.

The Electric Power Research Institute budget for 1976 is approximately 130 million dollars with funding provided by voluntary contributions from public and private utilities across the nation.

There are more than 500 member organizations supporting the EPRI program. These utilities account for more than 80 percent of the electric power generating capacity of the nation. The EPRI research programs are closely coordinated with parallel efforts of federal agencies such as the Energy Research and Development Administration, NASA and others.

The EPRI solar energy program is complementary in nature to the parallel ERDA program and emphasizes those aspects of solar energy research and development requiring utility interfacing and for covering such areas that we feel need additional emphasis. The EPRI solar program is quite broad in scope and is anticipated to be funded at a 22 million dollar level for the five year time period, 1976-1980. The EPRI Solar program parallels the ERDA programs to incorporate research and development in solar heating and cooling of buildings, solar thermal conversion, photovoltaic energy conversion, wind energy conversion, environmental impact assessment, materials and components testing as well as technical assessment of new and innovative approaches.

The EPRI solar program objectives are to make an independent assessment of solar energy applications; to make a comparative evaluation of alternative concepts; to inform the utility industry

of the potential and credibility of solar applications; and to set project priorities for demonstration of preferred systems which have wide geographic applicability. The program thrusts are to establish the preferred roles of alternative solar applications; to establish system requirements and to evaluate the impact on the electric utility industry; to conduct selective subsystem and system experiments of preferred systems; and to develop materials and components performance data necessary for reliable and economic operation of such systems. Furthermore, independent evaluation of the available insolation is to be assessed by a utility network of measurements; and finally the program will incorporate a flexible budget to provide for new and innovative approaches that were not previously identified in the program plan.

The application of solar energy for the production of power is not new. The first modern engineering effort was made in Egypt in 1913 by Frank Schuman who employed 13,000 sq ft of cylindrical trough reflectors to focus solar energy on a water-filled tube. The resulting steam powered a 55 hp reciprocating engine. Little progress was made until the late 1950's when the French built a 1,000 KW(th) solar furnace for high temperature materials research. More recently, Dr. Francia built a 100 KW(th) central receiver in Genoa, Italy, producing super heated steam at 950°F and 2000 psig. A smaller 35 KW(th) test furnace exists also in White Sands, New Mexico. Modern photovoltaic devices date from 1954 when the single crystal silicon solar cell was invented. Over the past 15 years the cell has been used extensively in the space program as a prime source of electrical power. In addition to space power applications, there is a small market for solar cell arrays on earth, primarily for remote power in navigational aides and communication repeaters. Wind energy has a long tradition of use on a distributed basis in rural America as well as in the other parts in the world. Its main application has been with regard to irrigation pumping of water, while ocean thermal differences of as little as 30°F have been used with some technical success to generate power.

Because technical feasibility of solar energy systems has been demonstrated one could raise the question why so much money is expended on solar energy technology without significant application in the near term. The problem is primarily one of economics and reliability. Even though solar energy is an intriguing and promising alternative to supplement the nation's power generating system, because it is virtually inexhaustible, is widely distributed and is not expected to introduce major environmental problems, it has two major drawbacks. The first relates to the diffused nature of solar energy, making solar energy systems capital intensive, requiring long operating lifetimes (15-30 years) for amortization. The second problem is related to the intermittent nature of solar energy, requiring all solar applications to incorporate energy storage. Because of the high cost of energy storage, the amount of storage for solar systems applications is limited, consequently, solar energy systems inherently have a low reliability of operation as compared to conventional power sources.

Conventional power sources, in addition to scheduled outages for maintenance, incur unscheduled outages due to component failures on a statistical basis. Solar energy systems for electric power generation have, in addition to component failures which occur on a statistically random basis, unscheduled outages due to cloud cover which have a high correlation from one power plant to the next. Consequently, when such solar systems are incorporated into a utility grid network, such systems must be backed up by conventional power systems to provide for the same overall high reliability characteristic of the electric power delivery. This reliability criterion is expressed by a loss of load probability (which occurs when the generation capacity is insufficient to meet the electric power demand). When solar energy systems with a highly correlated outage due to cloudcover are incorporated into a utility grid network, the amount of solar capacity is limited to only fifteen to twenty percent of the total installed capacity in order to maintain the same reliability as conventional systems. Furthermore, because of the high cost of energy storage, such solar power plants are anticipated

to operate only during the daytime hours (intermediate load applications). In summary, a major objective of the EPRI program is thus to develop solar power plants that have capacity displacement in addition to energy displacement.

The solar electric power system requirements, consequently, are to displace scarce energy resources, such as gas and oil, while incorporating sufficient energy storage such that solar power plants have capacity displacement. As such total capital investment is minimized by reducing the requirement for conventional power plant backup. Furthermore, because of the capital intense nature of solar energy systems, long operating lifetimes are required for capital payback, as well as high reliability of operation characteristic of conventional power plants. A final requirement is to minimize the environmental impact due to electric power production, by incorporating solar energy systems.

These requirements are considered for each of the solar energy alternatives for the production of electric power. Within this electric utility framework a summary of the key issues, problems and projected potential for each of the four major solar energy alternatives can be provided.

The reasons for this semi-annual program review and workshop format are to bring together the EPRI contractors, review committees, utility sponsors and invited federal and state representatives for the purpose of:

- (1) detailed quarterly review of each EPRI contractor by the review committee in one location to economize on time and travel expenses
- (2) to communicate to our utility sponsors the objectives and accomplishments of the EPRI solar program
- (3) to inform the federal and state representatives regarding the interests and concerns of the utility industry regarding the potential of solar programs
- (4) to exchange information between the various contractors

- (5) to meet with the EPRI Solar Program Committee and the Eastern and Western Solar Working Groups

The format of the meeting is to have formal (mostly one-hour) briefings by each of the EPRI contractors in the morning; and informal detailed quarterly project reviews with individual contractors in the afternoon (as indicated on the "pink" program schedule).

The latter review meetings will be restricted to the individual project contractor and review panel members to keep the meeting small and effective.

The schedule of the formal presentations is:

- (1) SHACOB - this morning and Thursday morning
- (2) STC - Tuesday and Wednesday mornings
- (3) SMCTF and SDV - Wednesday morning
- (4) EIA, PHOTOV. - Thursday morning

On Wednesday afternoon (and possibly evening) there will be a simultaneous meeting of the EPRI Solar Program Committee and the Eastern and Western Solar Working Groups to review the

- (1) Goal and Objective of the EPRI solar energy program, and
- (2) To address projects requiring immediate attention.

This meeting will be restricted to members of these committees.

Since this is the first semi-annual solar program meeting, we are interested in your comments and/or suggestions on the meeting, format, location, etc. A form has been provided for this purpose.

In addition, to obtain inputs regarding specific EPRI projects or contracts or the overall EPRI solar energy program from those who are not part of any review or program committee, two types of forms have been provided. The first form can be given to the project manager and the second to the Program Committee Chairman, Dr. Val Finlayson.

Even though many of the projects have only been underway for a relatively short time, I hope that you will find this meeting to be informative and to achieve the objectives that I have set forth, namely:

- (1) to communicate the information derived from the various EPRI solar projects and contracts
- (2) to effectively interface with our counterparts in the federal and state programs as well as
- (3) to conduct effective quarterly review with our contractors.

ERDA/DSE PROGRAM OVERVIEW
A BRIEF DESCRIPTION OF THE ERDA SOLAR PROGRAM
COVERING CURRENT AND PROJECTED ACTIVITIES IN THE THERMAL
APPLICATIONS AND ELECTRIC APPLICATIONS

UNITED STATES
ENERGY RESEARCH AND DEVELOPMENT ADMINISTRATION
DIVISION OF SOLAR ENERGY
20 MASSACHUSETTS AVENUE, N.W.
WASHINGTON, D. C. 20545

JAMES E. RANNELS
PROGRAM MANAGER
(202) 376-4462

MARCH 1976
EPRI SOLAR REVIEW MEETING #1

SOLAR ENERGY BUDGET BUDGET AUTHORITY (\$ IN MILLIONS)

	FY 76	FY 77
● OPERATING EXPENSE		
THERMAL APPLICATIONS	\$ 39.8	\$ 49.2
TECHNOLOGY SUPPORT AND UTILIZATION	5.4	4.0
SOLAR ELECTRIC APPLICATIONS	58.9	84.3
FUELS FROM BIOMASS	<u>4.5</u>	<u>4.3</u>
TOTAL	\$ 108.6	\$ 141.8
● PLANT AND CAPITAL EQUIPMENT		
	<u>6.0</u>	<u>18.2</u>
TOTAL AUTHORITY	\$ 114.6	\$ 160.0
TOTAL OUTLAY	(\$86.0)	(\$115.9)

Chart I summarizes the FY 1977 solar energy budget request and compares it with the FY 1976 budget. The FY 1977 total represents a 30% increase over the funds appropriated for FY 1976. As indicated on the chart, the ERDA solar energy program is organized into four major subprograms. These are: (1) Thermal Applications; (2) Solar Electric Applications, (3) Fuels from Biomass; and (4) Technology Support and Utilization. The Biomass and Technology Support subprograms will be summarized here, while additional charts will describe the Solar Thermal and Solar Electric subprograms in more detail.

The objectives of the Fuels from Biomass subprogram are to develop and demonstrate the economic and technical feasibility, and environmental acceptability of utilizing agricultural and forestry residues, producing terrestrial and marine biomass and converting these organic materials to clean fuels, petrochemical substitutes, food and other energy-intensive products. The major R&D areas needing emphasis to achieve

large-scale cost competitive energy production are: biomass species selection and production, high efficiency conversion processes, and distribution and utilization of resultant fuels. The optimum combination of source, conversion process and type of fuel will be investigated through intensive research studies and experiments.

Technology Support and Utilization is the key subprogram in the solar energy program, since its principal goal is the successful commercialization of the technologies developed by the other subprograms. The subprogram provides for the systematic acquisition, analysis and dissemination of information to assure widespread utilization of developed technologies. It also provides for the continuing investigation and analysis of relevant solar technologies and their impacts. The subprogram consists of three categories: Environmental and Resource Assessment; the Solar Energy Research Institute; and Information Dissemination and Commercialization.

**THERMAL APPLICATIONS
BUDGET AUTHORITY
(\$ IN MILLIONS)**

	<u>FY 76</u>	<u>FY 77</u>
● HEATING AND COOLING		
COMMERCIAL	\$18.2	\$16.7
RESIDENTIAL	5.9	8.1
RESEARCH AND DEVELOPMENT	5.0	10.5
DEVELOPMENT IN SUPPORT OF DEMONSTRATION	6.0	10.0
	<u>\$35.1</u>	<u>\$45.3</u>
● AGRICULTURAL AND INDUSTRIAL PROCESS HEAT		
	<u>4.7</u>	<u>3.9</u>
TOTAL AUTHORITY	\$39.8	\$49.2
TOTAL OUTLAY	(\$28.5)	(\$37.0)

Chart 2 breaks down the Thermal Applications budget into further detail. This subprogram consists of two major categories: (1) the solar heating and cooling of buildings and the supplying of service hot water; and (2) the use of solar energy to supply heat for agricultural and industrial process heat applications. The principal goal is the development of near-term commercialization through a series of experiments and demonstrations using available and improved technologies.

The Heating and Cooling of Buildings category has as its overall goal the stimulating of development of an industry to produce, distribute, and service solar hardware for residential and commercial hot water heating and space heating and cooling. The ERDA effort is structured to demonstrate the practical use of solar heating technology by the end of 1977 and combined heating and cooling technology by the end of 1979. This will be accomplished by a series of demonstration projects with new and existing

buildings and a vigorous research and development program. The R&D program should yield components having lower cost, greater durability and improved performance, as well as a significant advance in the ability to predict solar system performance. The first two demonstration cycles will concentrate on residential and commercial space heating and hot water supply, while subsequent cycles will emphasize combined space heating and cooling and hot water supply. The Agricultural and Industrial Process Heat category is designed to provide direction and incentives for applying state-of-the-art solar components and technology to agricultural and industrial heat processes. The basic strategy will be to use the R&D results of the Heating and Cooling of Buildings and Solar Thermal categories in a series of experiment and demonstration projects. Industry participation will be encouraged throughout the development and demonstration process to foster prompt commercial adoption.

PROGRAM ACCOMPLISHMENTS

- **PUBLISHED "NATIONAL PROGRAM FOR SOLAR HEATING AND COOLING"**
- **PUBLISHED "CATALOG ON SOLAR ENERGY HEATING AND COOLING PRODUCTS"**
- **ISSUED PROGRAM SOLICITATIONS**
- **INITIATED DEVELOPMENT IN SUPPORT OF DEMONSTRATION PROGRAM**
- **INITIATED INTERAGENCY PROJECTS AND PROGRAM SUPPORT**

Major accomplishments of the Heating and Cooling of Buildings program element.

- The "National Program for Solar Heating and Cooling" (ERDA-23A) was published in October 1975. This document describes in detail the Federal portion of the national program for the solar heating and cooling research, development and demonstration. This program plan will be revised and updated no later than October 1976.
- ERDA published the "Catalog on Solar Heating and Cooling Products" (ERDA-75) in November 1975. This reference on available hardware has proven very popular and has been widely distributed.
- Program solicitation for commercial heating and cooling demonstration projects and heating and cooling components were issued

in September 1975, and selections for contract negotiations have recently been announced. In addition, HUD has announced residential heating and cooling demonstration projects selected for contract negotiation.

- The Development in Support of Demonstrations program was also initiated at the NASA Marshall Space Flight Center. This program is designed to provide improved heating and cooling systems for later demonstration cycles.
- Inter-agency projects are now underway with several Federal agencies, including the National Bureau of Standards, DoD, NASA and HUD. Both DoD and HUD are conducting demonstration projects, NBS is developing performance criteria, and NASA, as mentioned above, is conducting the Development in Support of Demonstrations Program.

SOLAR HEATING PROJECTS PRIOR TO FY76

FY 76 PROJECT STARTS
 FY 76 HUD RESIDENTIAL
 FY 76 DOD RESIDENTIAL

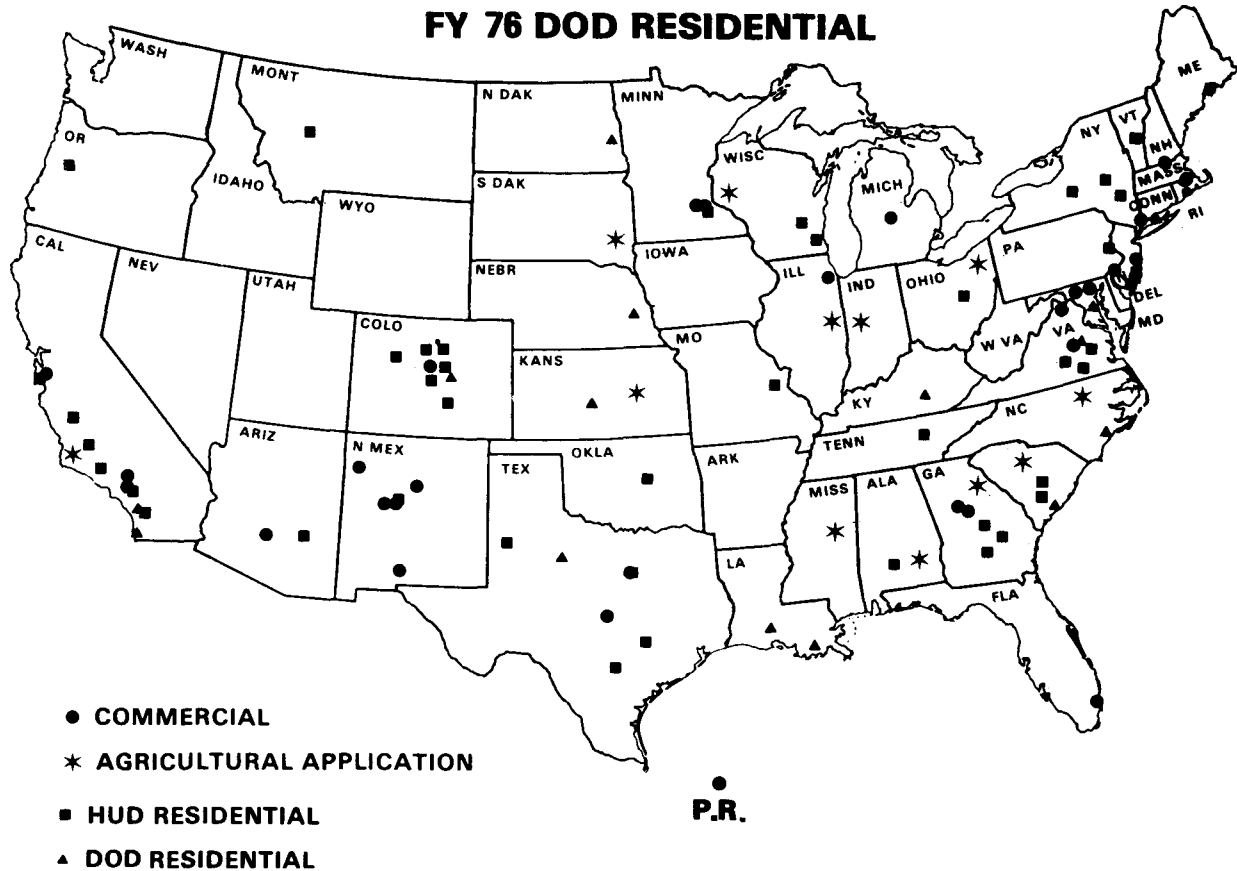

Chart 3 shows the locations of solar heating demonstration projects. The recently announced ERDA selections of commercial demon-

stration projects add another 34. The map includes projects initiated by the National Science Foundation before the formation of ERDA.

SOLAR ELECTRIC APPLICATIONS

FY 1977 BUDGET AUTHORITY

(\$ IN MILLIONS)

	FY 1976	FY 1977
I. OPERATING EXPENSES		
SOLAR THERMAL	\$ 14.3	\$ 30.9
PHOTOVOLTAIC	21.6	28.2
WIND ENERGY	14.9	16.0
OCEAN THERMAL	8.1	9.2
	\$ 58.9	\$ 84.3
II. CAPITAL EQUIPMENT AND CONSTRUCTION		
PHOTOVOLTAIC	\$.8	\$ 4.6
WIND	.2	1.1
5 MWT SOLAR THERMAL TEST FACILITY	5.0	10.0
10 MW ₀ CENTRAL RECEIVER PILOT PLANT	-0-	2.5
	\$ 6.0	\$ 18.2
TOTAL AUTHORITY	\$ 64.9	\$ 102.5
TOTAL OUTLAYS	(\$49.1)	(\$72.9)

Chart 4 details the Solar Electric Applications budget. This program element includes those technologies whose principal outlets can be electric power, but which also can produce other forms of energy such as thermal or mechanical energy. The program element consists of the categories of wind energy, photovoltaic energy, solar thermal energy and ocean thermal energy. The primary objective is to develop and demonstrate these technologies for collection and conversion in order to make possible an initial energy contribution before 1985 and a moderate contribution by 2000.

Solar Thermal, wind, and ocean thermal may be

employed either for intermediate or peak applications due to the variable nature of the solar or wind resource. In these cases, energy storage may provide the operational flexibility for cloudy or low wind velocity periods. These systems will be complementary to oil, gas and hydroelectric power plants either individually, as a hybrid plant or through the utility grid network. Ocean thermal has the potential to provide significant quantities of baseload electric power.

This program, if successfully implemented, could provide as much as 15% of the Nation's total electric capacity and 8% of the projected energy demand by 2020.

Major activities in the Solar Thermal category for FY 1977.

- A concept will be selected for a 10 MWe solar electric pilot plant. Four major system studies were initiated on a central receiver system at the end of FY 1975. Each study presented a different system approach, as well as different subsystem elements. Two of the studies involved cavity receiver concept. The third contractor proposed an external receiver, or non-cavity design, while the fourth contractor presented only a unique heliostat concept and not a total system. Final selection will be accomplished in FY 1977.
- Conceptual design of a 5 MW Solar Thermal Test Facility, located at Albuquerque, New Mexico, has been completed and detailed design and initial construction is being initiated. A 1 MW testing capability will be attained during FY 1977.
- The first quadrant of the Total Energy Test Bed has been completed, consisting of approximately 2000 square feet of parabolic trough distributed concentrators and a 40 kWe organic Rankine cycle turbine. The three remaining quadrants, with different distributed collector concepts, will be added in FY 1977.

Major activities in the Wind Energy category for FY 1977.

- The fabrication and installation of two multi-hundred kilowatt wind energy systems will be completed. These systems will be at two climatically different sites in cooperation with utilities in order to obtain early operational information in a user environment.
- Final design and fabrication of the first of two 1.5 MWe wind energy systems will be completed. These systems will also be installed at different sites in cooperation with utilities. They will be tested through FY 1978 and 1979.

- Research is underway on several innovative and unconventional concepts such as the vertical axis Darrieus rotor being tested at Sandia Laboratories, Albuquerque. Model field testing will be initiated in FY 1977.
- Projects will be undertaken, in cooperation with the U.S. Department of Agriculture, to examine and develop possible rural home and agricultural applications for small-size wind energy systems. Applications include on-site fertilizer manufacture by electrolysis of water to produce hydrogen, direct space heating, crop drying and irrigation. Field testing will be initiated in FY 1977.

Major FY 1977 solar photovoltaic activities.

- Baseline photovoltaic systems and applications will be selected. These could include systems for residential and defense applications. Applications with the potential for early user acceptance and a systematic scale-up of industry capability and participation will be emphasized. Development of low-cost silicon cell arrays will also be continued.
- A major series of experiments with multi-kilowatt photovoltaic systems will be continued. These systems will include remote applications, DoD applications and residential prototype systems. One such application is a 10.8 kW system for water purification. It is designed to produce 360 gallons per minute of potable water from lakes and streams.
- The first solar collector/photovoltaic tests will be conducted with the goal of attaining a price of less than \$2,000 per peak kilowatt for concentrating systems by FY 1979. The concentrating system will have a 10% efficiency under an intensity equivalent to 40 times the normal insolation.

Chart 9 indicates the major Ocean Thermal Energy Conversion (OTEC) activities for FY 1977.

- The OTEC program is now evolving from system studies into the hardware development phase. Several technical challenges exist in the design and development of critical components such as very large long-life heat exchangers which must operate in an ocean environment characterized by severe corrosion and biofouling. These heat exchangers must possess high heat transfer rates, low cost and long life. Testing and development programs will be implemented in FY 1977.
- Studies of program planning alternatives and their cost-benefit-risk tradeoffs will be completed.
- The development of site selection and conceptual design criteria for an OTEC engineering test facility will be completed. Both near-shore and off-shore alternatives will be evaluated, and test hardware procurement will be initiated.
- Critical components and subsystems will be developed and initially tested to provide the most promising options for the selection and construction of candidate designs for large-scale testing in the engineering test facility.

ACTIVITY/MILESTONE SCHEDULE

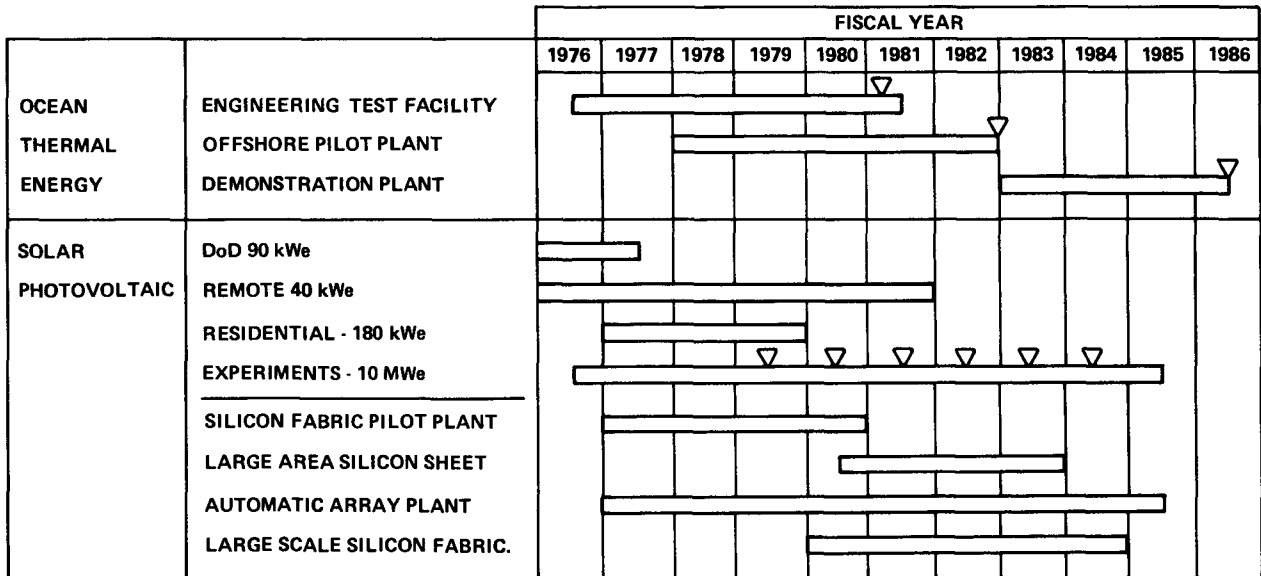

▽ INITIAL OPERATION

ACTIVITY/MILESTONE SCHEDULE (continued)

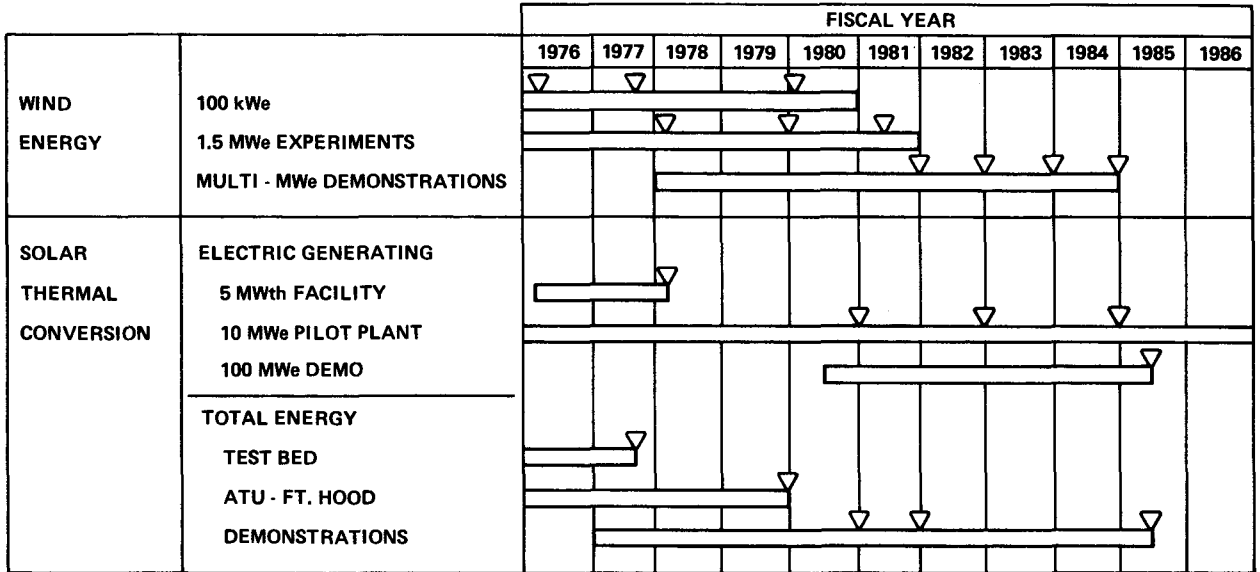

▽ INITIAL OPERATION

Charts 5 and 6 illustrate the solar electric activities and their milestones for the year FY 1976 - FY 1986. It is an ambitious program

and one which should provide many of the answers needed for commercial adoption of these technologies.

EPRI CONTRACT RP 553

SOLAR HEATING AND COOLING OF BUILDINGS
REQUIREMENTS DEFINITION AND IMPACT ANALYSIS

THE AEROSPACE CORPORATION
Energy and Transportation Division
El Segundo, California 90245

PROGRAM MANAGER

WALT MELTON
(213) 648-6193

MARCH 1976
EPRI SOLAR REVIEW MEETING #1

SHACOB

Requirements Definition and Impact Analysis

STUDY OBJECTIVES

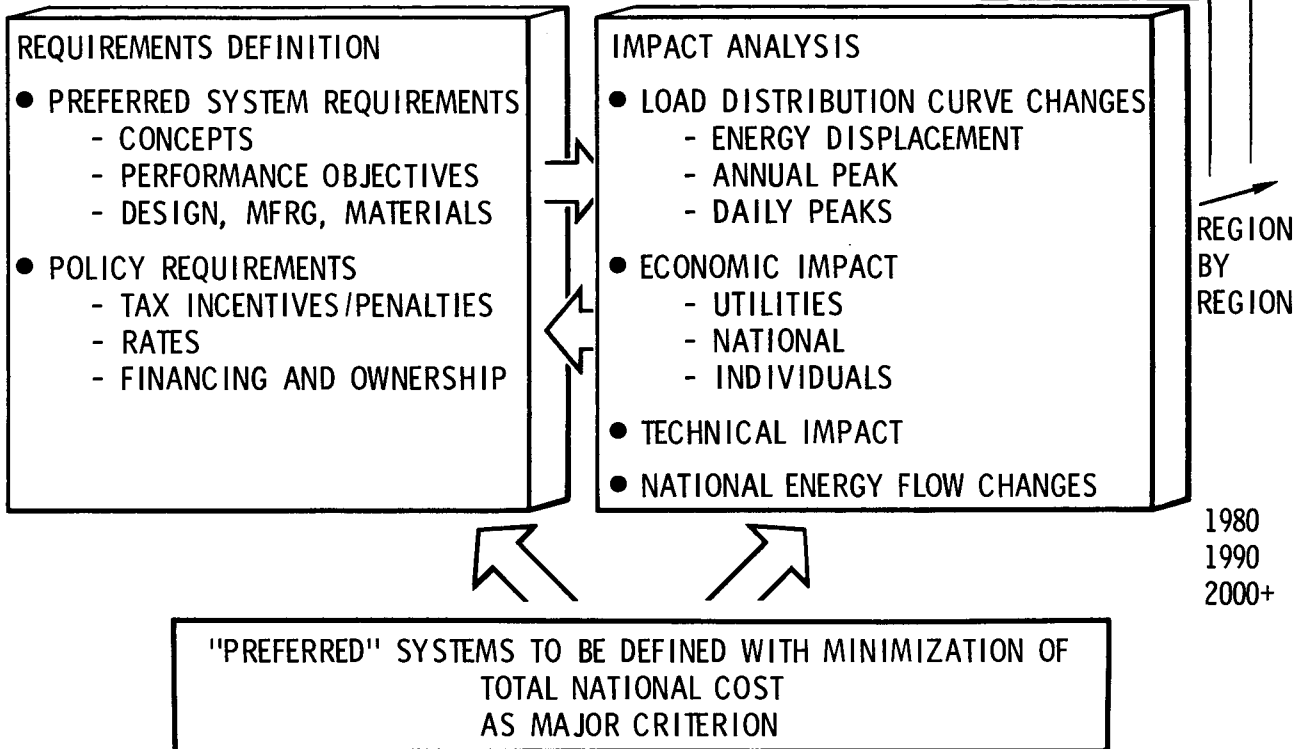

OVERVIEW

There are two main thrusts to this SHACOB study:

(1) Defining the preferred SHACOB concepts and their operating performance objectives and nominal design parameter values (a workable concept can have a reverse effect if poorly designed) and

(2) analyzing the economic and technical impact on the utilities in particular and the nation in general. The two parts are coupled together, of course. The impact analysis will lead to modifi-

cations of the definition of preferred systems. The impact analysis, especially regarding the utility impact, will be done for each region of the country, and is to be predicted out to the years 2000+. There are many fold criteria for the "preferred" systems but the single paramount criterion is that the impact must be minimized in terms of total national cost.

SHACOB

Requirements Definition and Impact Analysis

WHICH IS BEST? – UNDER WHAT CONDITIONS?

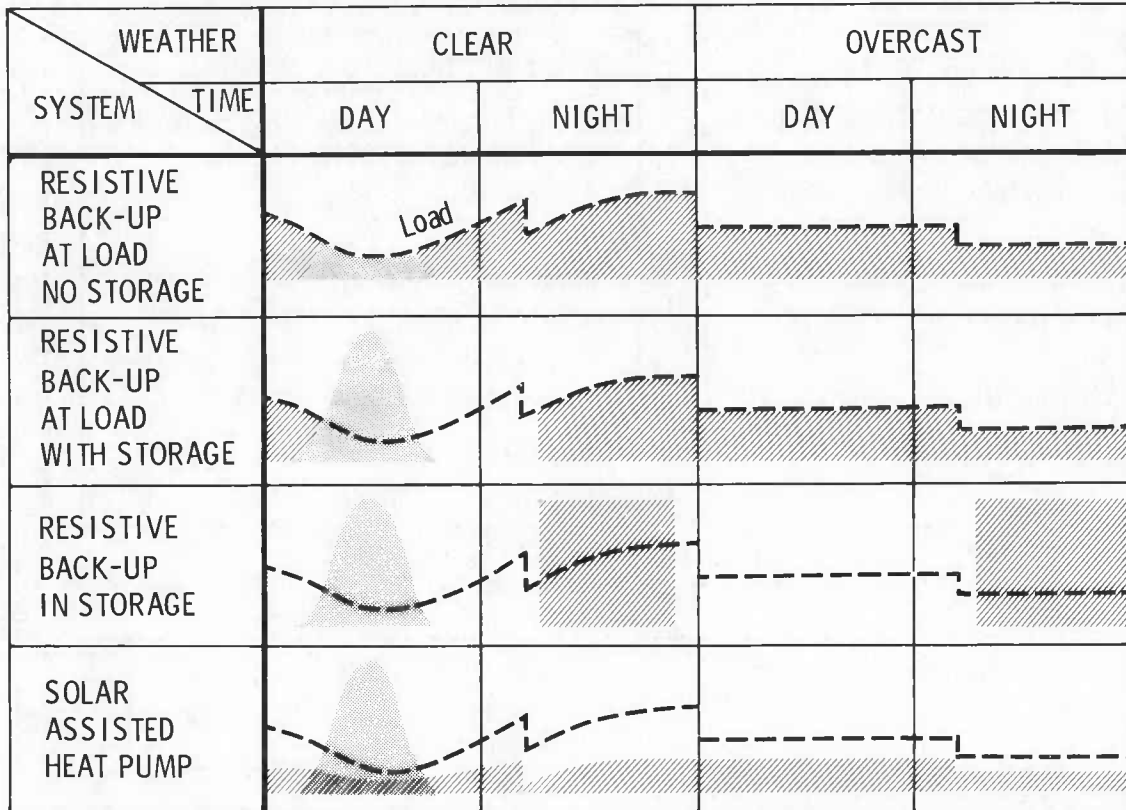

Four generic heating systems and how they would respond to a clear-day load and an overcast-day load are illustrated for discussion. The dashed line is the load which is presumed the same for all four systems. It would appear that the SHAC with resistive back-up in storage and the solar-assisted heat pump are the most desirable, but the objective of the study is to quantify that. Also, how undesirable are the top two from the utility point of view? Note that on clear days (which are often quite cold) the daytime utility demand will be decreased by all four systems. Winter peaking invariable occurs during daylight hours, and therefore all four systems should reduce winter peaks if they occur on clear days. The illustrated overcast day is very dark, on the order of 30% possible total insolation. These meteorological conditions will occur 20 to 30% of the time in the winter in all areas but the south-west. No solar energy will be obtained on such

days and, because they often occur in chains of two or more days in a row, it is assumed in the chart that there is no useful solar energy in storage. Therefore, the utility must assume the entire load. The system with resistive backup in storage permits load management. The other three systems might very well contribute to the winter peak, if such a peak occurs on a cloudy day. A major requirement is to generate temperature statistics for cloudy days: (1) As presumed in the chart, are they warmer on the average? and (2) as presumed on the chart, do they have flat (easy-to-analyze) temperature profiles? Much of the future analysis will focus on overcast days because they appear to be the ones which will contribute to peaking capacity requirements. There are types of SHAC systems other than shown on the chart, and different details of those shown might provide different responses. The chart is expositional.

SHACOB Requirements Definition and Impact Analysis

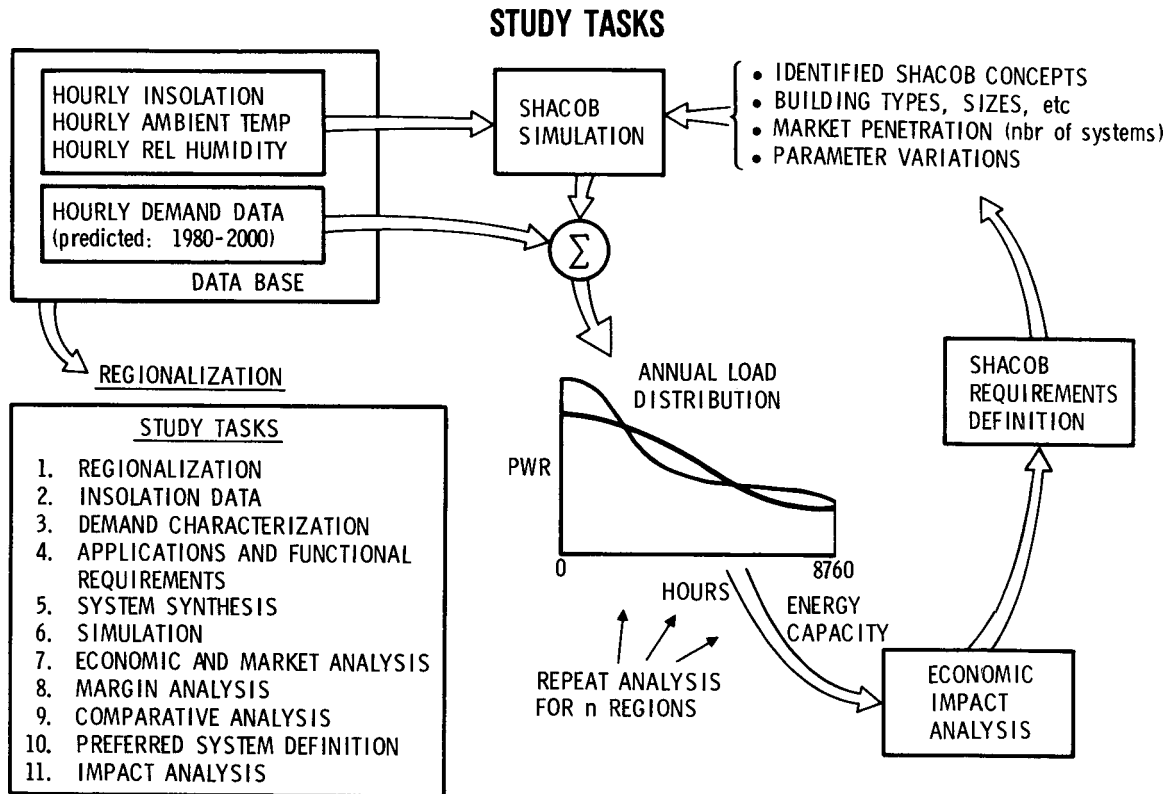

The study Statement of Work (SOW) defines the 11 tasks listed on the lower left, and they are distributed throughout the upper diagram. The data base development and related analyses are well underway. This is one of the main topics in this document. The simulation of SHACOB operations for various types of systems and buildings is required to gather utility demand data to predict (statistically) the change in the utility load duration curve. This analysis must be repeated for each distinct utility/climatology region. The changes in this curve (in terms of energy

and capacity distribution as reflected in the analysis of capacity margin) impact utility economics as well as national economics. SHACOB concept selection (and design values for the concepts) will be modified to optimize the economic impact, thus revising the types and numbers of SHACOBs for each region. The upper righthand analysis chain is a closed loop which we will circle once, and for some SHACOB concepts, several times in the next two years. At that time we will exit the loop with requirements definition and an economic impact statement.

SHACOB

Requirements Definition and Impact Analysis

STUDY GUIDELINES

- QUANTITATIVE DATA TO SUPPORT CONCLUSIONS
- CONSISTENT LEVEL OF ACCURACY THROUGH STUDY ELEMENTS
 - EXCEPTION: MARKET PENETRATION
- MAJOR EFFECTS EMPHASIZED
- HIGH QUALITY DATA BASE DEVELOPED AND PRESERVED

● As a general rule in this study, the policy is to be as quantitative as possible in supporting conclusions. Nothing destroys credibility faster than qualitative judgmental support of conclusions. ● The attempt will be to maintain a uniform and consistent level of accuracy through all elements of the study. That is, for example, we won't get bogged down with the details of a SHACOB loads simulation to the exclusion of the analysis of how the makeup demand impacts capacity margins. However, difficulty is anticipated in accurately predicting SHACOB market penetration -- it is

proposed instead to treat this effect parametrically. ● Emphasis will be on the major effects (Pareto's Law), but will examine smaller effects to determine the conditions under which they are smaller, by thorough analysis. ● It will probably result in current study effort being incomplete to the extent that other ideas and SHACOB concepts will come to the fore toward the end of the study and after, and it is desirable to be in a position to rapidly and efficiently assess those situations. So, care will be taken in establishing and preserving the data base.

SHACOB

Requirements Definition and Impact Analysis

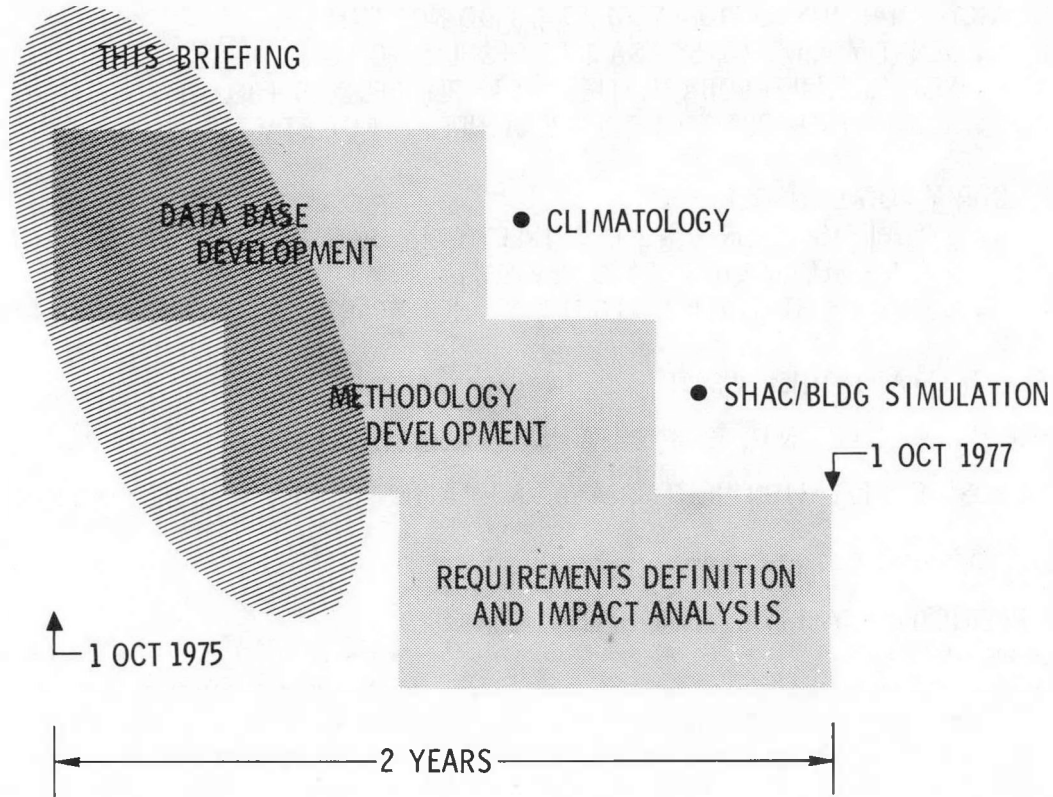

The study is technically phased in three sections which overlap somewhat in time: (1) Data Base Development, (2) Methodology Development, and (3) the analysis phase, "Requirements Definition and Impact Analysis," which is the eventual objective of the study as defined on an earlier chart.

These three phases are interrelated, of course. For example, the data base must to some extent reflect the methodology that is developed. The remainder of this report addresses the plans and progress that have been made in the data base development and methodology development areas.

SHACOB

Requirements Definition and Impact Analysis

DATA BASE DEVELOPMENT SUMMARY STATUS

- INSOLATION
 - DAILY TOTAL INSOLATION AVERAGES EXIST – NO WORK REQUIRED
 - DAILY TOTAL INSOLATION STATISTICS DO NOT EXIST
 - DENSITY FUNCTIONS – SAMPLE RESULTS FOLLOW
 - PERSISTENCE PROBABILITIES – SAMPLE RESULTS FOLLOW
 - JOINT DISTRIBUTION OF TEMPERATURES – NOT STARTED
 - HOURLY TOTAL INSOLATION
 - SYNTHESIS TECHNIQUES REQUIRED, ONLY 30 STATIONS WITH EXTENSIVE DATA – TECHNIQUES BEING REVIEWED
 - SUMMARY STATISTICS REQUIRED – NOT STARTED
- TEMPERATURE AND OTHER WEATHER DATA
 - DAILY MAX AND MIN TEMP DATA \longleftrightarrow DAILY INSOLATION
 - CROSS CORRELATION OF TEMP AND INSOLATION (hourly) – UNDER REVIEW
- HOURLY DEMAND DATA
 - PREDICTED STATISTICS FOR 1980 \rightarrow 2000 +

● It must be recognized that the climatology (temperature, relative humidity, and insolation) and building energy loads as a consequence of the climatology dictate the design of that system and its consequent performance. Therefore, a thorough understanding of the nature of the driving functions is important, especially for the calculation of performance (or lack of performance) and interpretation of the results.

● Daily insolation averages exist and are published extensively in many different forms. No further work or analysis is required. ● Some density function data exist and are crudely summarized in an ASHRAE report ("Low Temperature Engineering Application of Solar Energy") and no data on day-to-day insolation persistence have been published to our knowledge, so those analyses have been undertaken and they are almost completed. Sample results are shown later in this report. The daily insolation records for this analysis already existed in the Aerospace data bank. The analysis of utility makeup energy requirements on cloudy days can be speeded up (this is a hypothesis), if the joint distributions of temperature are developed for overcast days (<30% possible total insolation). The daily max/min temperature data corresponding in time and location to daily insolation data have been ordered from NCC. It is expected that very little temperature variation will be found on low-insolation days, thus speeding the loads calculations for sunless days. It is hypothesized that those days

tend to be warmer, too. This will be checked. ● There are only 30 stations with extensive hourly insolation data. There is a large amount of these data in the Aerospace data base, and the additional amount to fill out the first 10 years of operation for each station have been ordered from NCC. These data will be used to examine synthesis techniques -- it is expected that, in many instances, existing insolation sequences at one location are statistically the same as at another location when weighted by daily insolation frequency functions. If so, no synthesis using cloud cover records, etc., will be required at all. ● The relationship between daily insolation and temperature max, min, and mean will be established as mentioned above. The cross-correlation of hourly temperature and insolation for sunny and intermittent days will be evaluated (taken about the hourly means, not the seasonal means as done in earlier research) to ascertain if the correlations are low enough to statistically divorce the loads analysis from the SHAC analysis. Considerable savings in computation may be realized if this turns out to be the case. This work is just starting using an hourly data tape for Columbia, Missouri. ● Hourly demand data for about 40 utilities for periods from 1 to 10 years already exist in the Aerospace data bases. Plans for statistically summarizing these data and for obtaining (through EPRI) additional data, or preferably statistics, are underway.

SHACOB Requirements Definition and Impact Analysis

DAILY TOTAL INSOLATION DATA AVAILABILITY

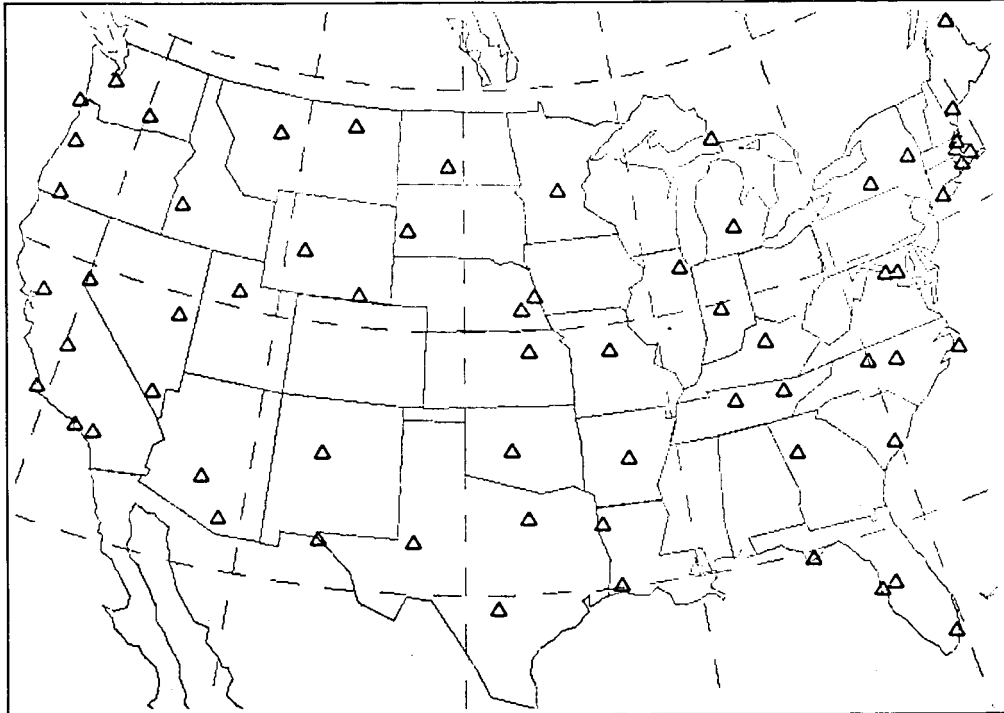

CRITERIA: MORE THAN 2 YEARS OF DATA
LESS THAN 10% MISSING

This map shows the locations for which daily insolation data exist to the extent required to generate meaningful distributions and persistence probabilities. Analysis of the Aerospace data base shows that there are 63 stations for which there are at least 2 years of data and for which fewer than 10% of the days missing. The stations

are fairly uniformly distributed around the country with the exception of the Colorado-Utah and Alabama-Mississippi areas which are relatively low in population density. The next few charts show samples of the frequency distributions and persistence probabilities calculated for these stations.

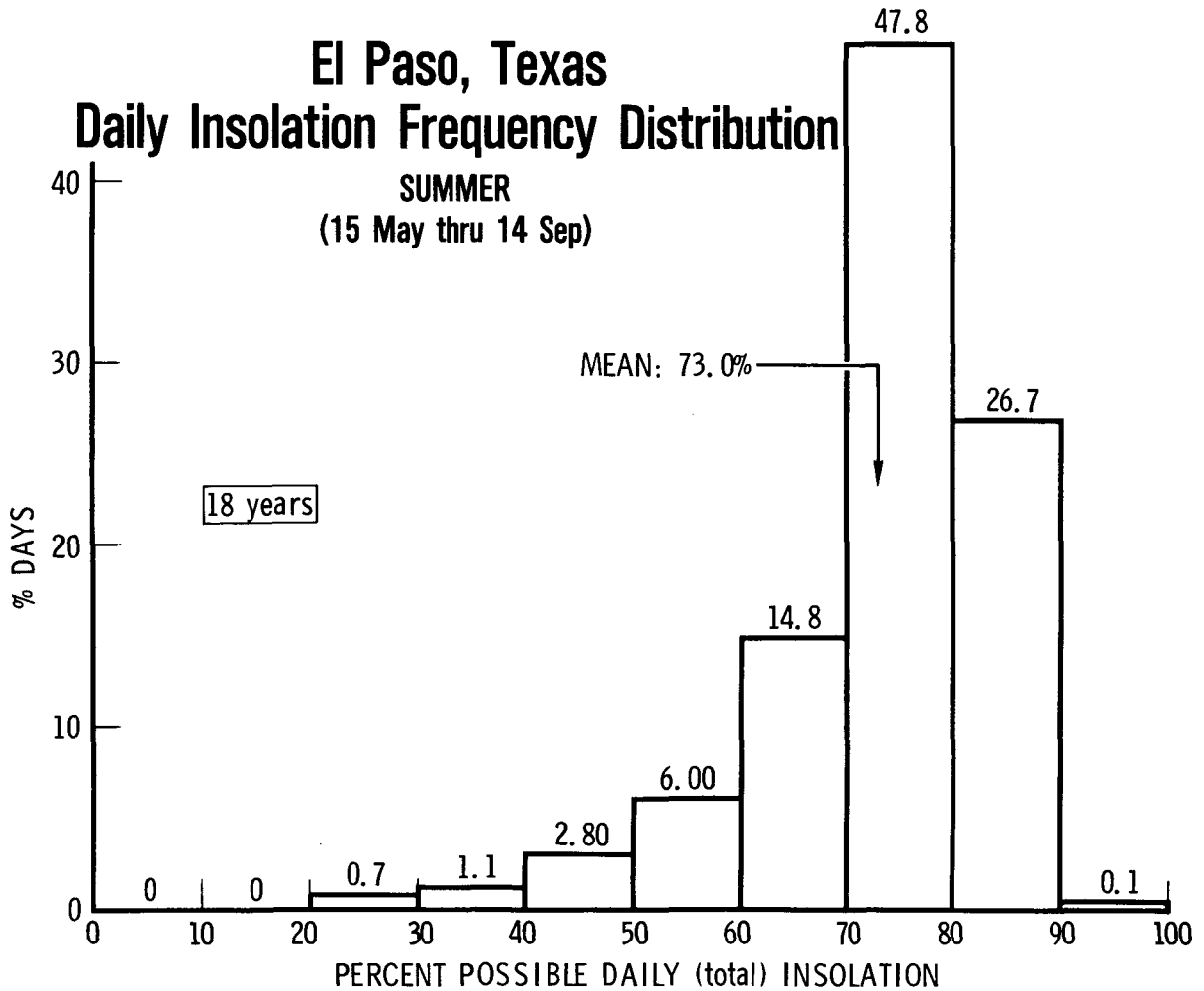

As a sample, this is the histogram (frequency distribution) for percent possible daily total insolation for El Paso, Texas. "Total insolation" is defined as direct plus diffuse on a horizontal flat plate, and by "percent possible" is meant the ratio between the sum of the insolation recorded for a particular day and the sum that would have obtained if there were no atmosphere (a trigonometric calculation combined with the solar constant). This histogram is based on

18 years of data. To facilitate contouring and comparing different regions of the country, the year has been divided into the following three seasons for all locations independent of the temperature statistics for the locations:

- (1) summer season: 15 May through 14 Sep.
- (2) winter season: 15 Nov. through 14 March,
- and (3) transition season: 15 March through 14 May, plus 15 Sep. through 14 Nov.

El Paso is sunny in the summer.

Columbia, Missouri Daily Insolation Frequency Distribution Summer

(15 May thru 14 Sep)

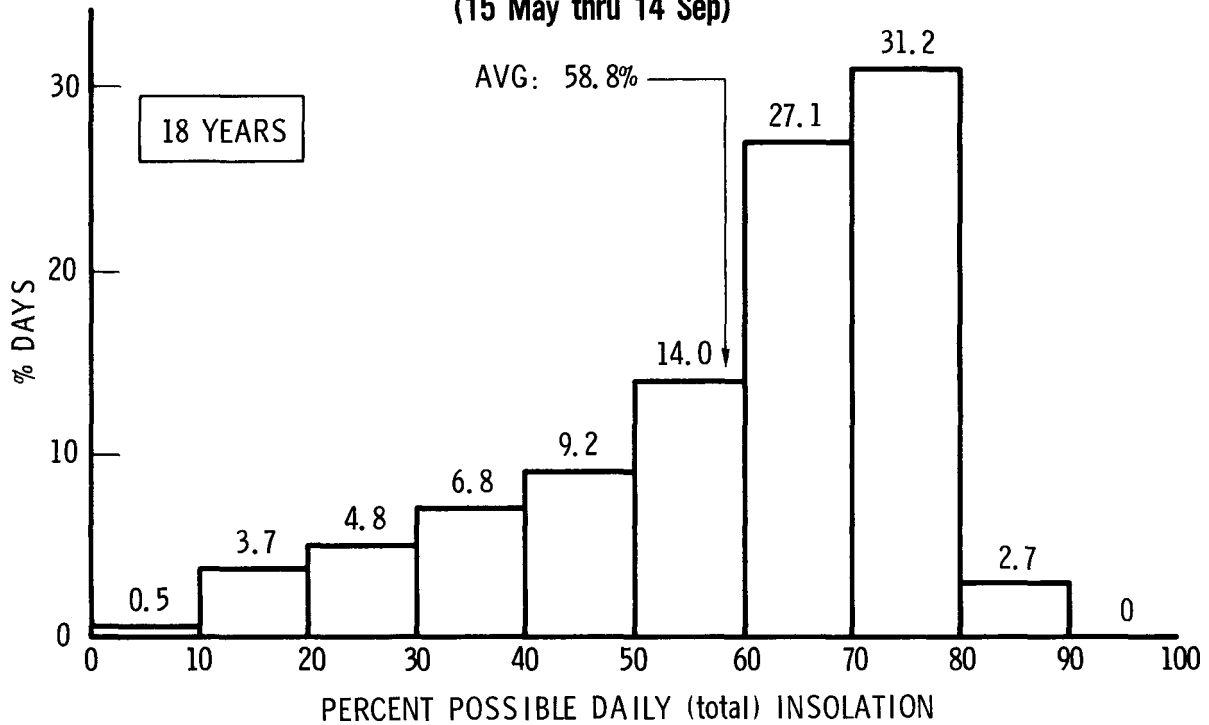

This is the histogram for summer in Columbia, Missouri. It is shifted to the left with respect to El Paso.

Columbia, Missouri Daily Insolation Frequency Distribution Winter

(15 Nov thru 14 Mar)

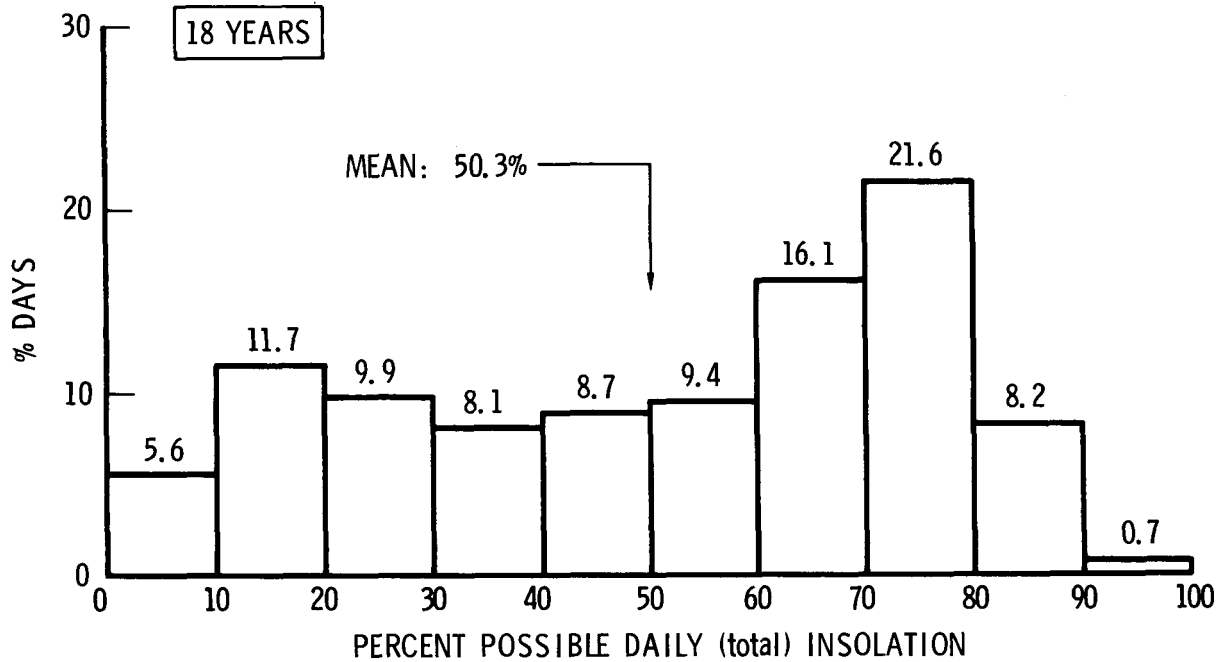

This histogram for Columbia winters exhibits a fairly typical double-humped distribution. Of particular interest is the low insolation tail of the distribution for use in the peaking analysis. For almost all systems (in cold

weather), no solar energy can be extracted for overcast days with less than about 30% possible insolation. Note that this occurs on 27% of the days in Columbia, or on 32 days in the arbitrarily defined 120-day winter season.

Columbia, Missouri

Cumulative Probability of Successive-Day Insolation

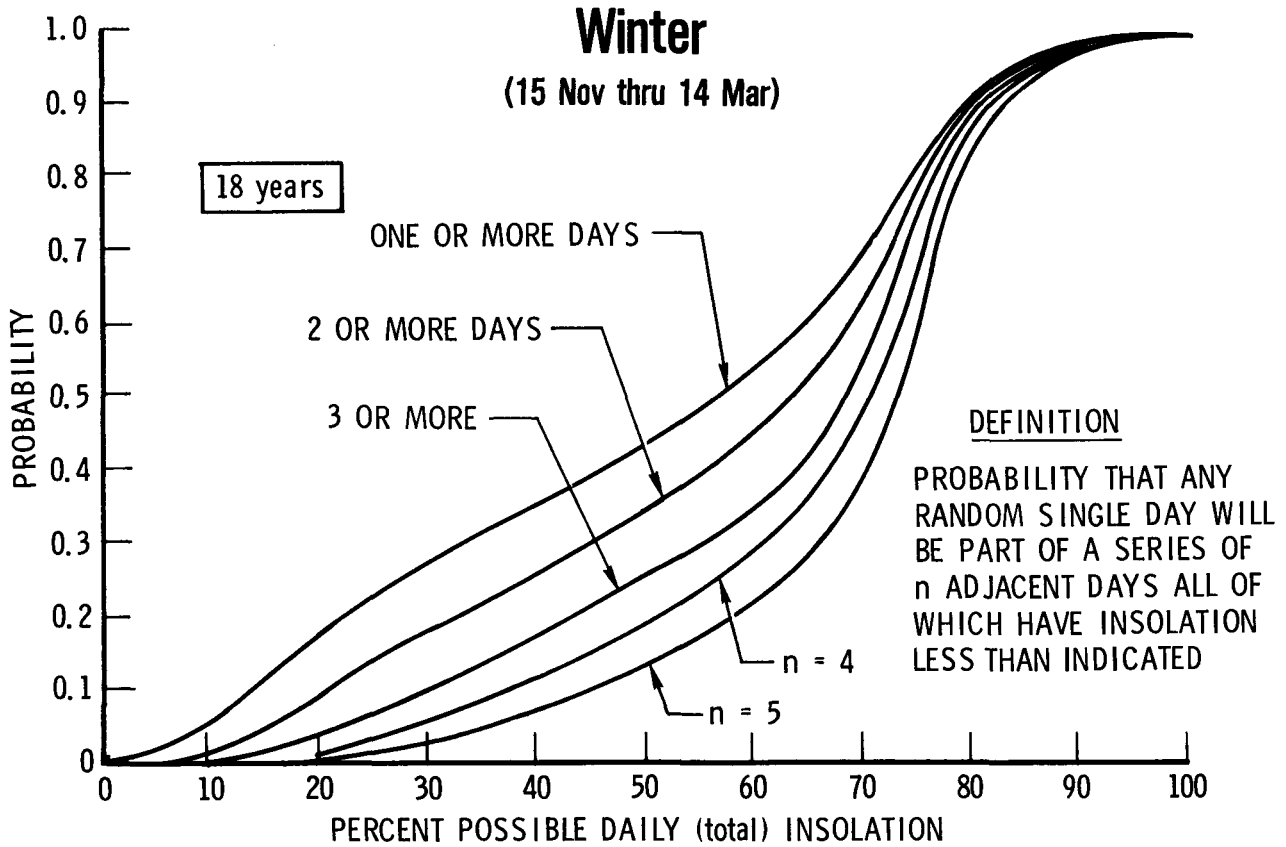

These curves give the probability that a single day drawn at random from the season (120 days) will be in a chain of n successive days or longer for which each day has insolation less than that indicated on the abscissa. The curve for one or more days is therefore simply the cumulative distribution curve for the preceding frequency distribution (Columbia, Missouri in the winter). The indicated probability multiplied by 120 is

the expected number of winter days which will occur in groups of n days or longer for which each day in the group has less than the indicated percent possible total insolation. For example, the expected number of days per winter which will occur in sequences of 3 or greater and all have less than 30% possible insolation is 0.10×120 , or, 12 days.

El Paso, Texas

Cumulative Probability of Successive-Day Insolation

Summer (15 May thru 14 Sept)

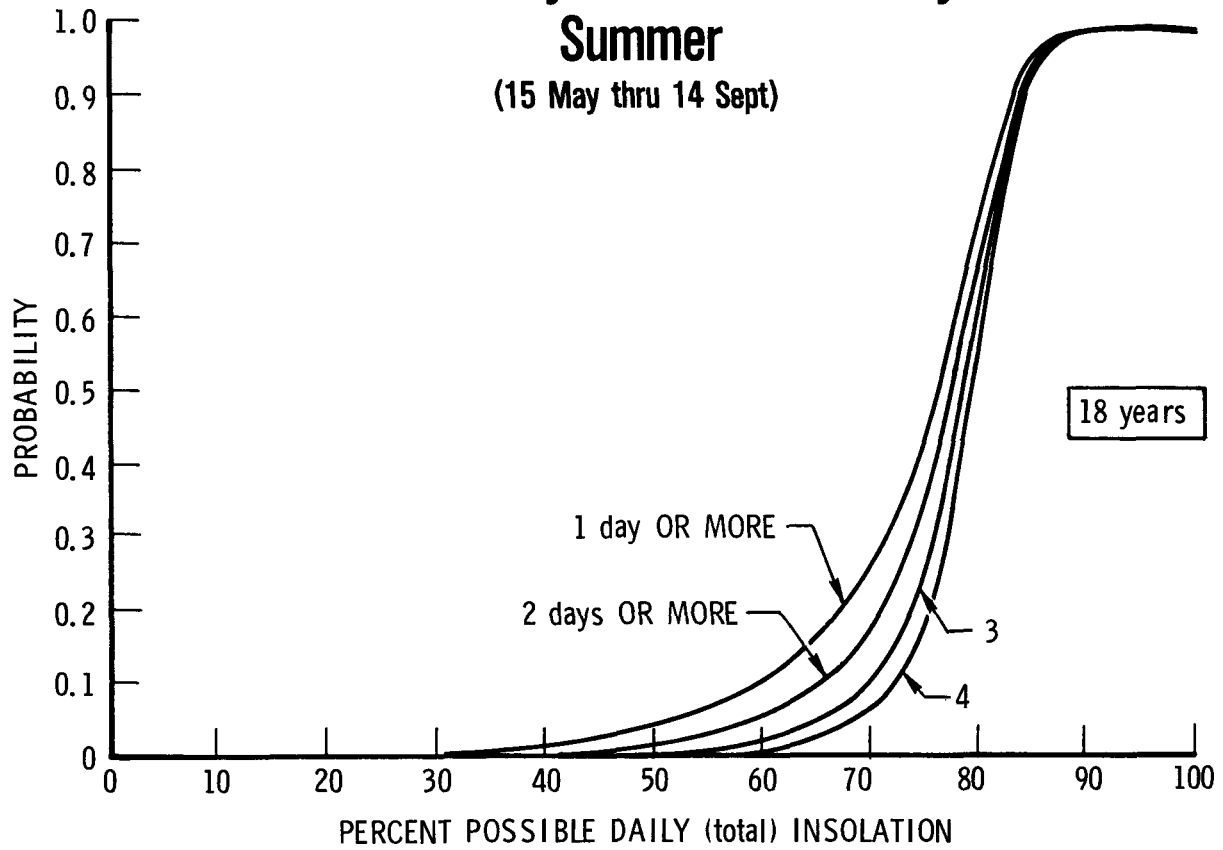

This chart shows, for example, that in 18 years of summer data at El Paso, there were never more than 3 days in a row for which the insolation was

less than 60%. That is, the curve labeled "4" is zero at 60% insolation. As stated, El Paso is sunny in the summer.

Los Angeles Daily Insolation Frequency Distributions

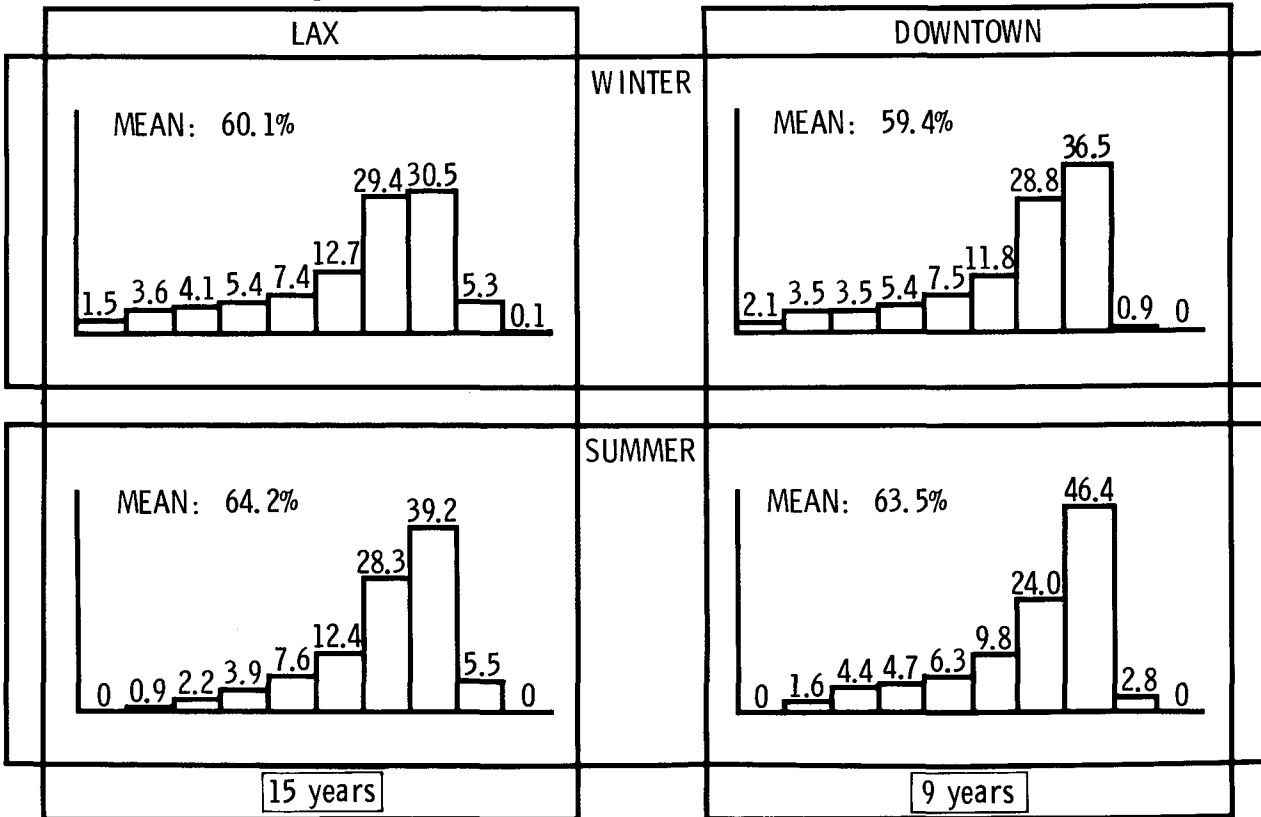

This chart compares Los Angeles International Airport (LAX) with downtown Los Angeles for both

winter and summer. All four distributions are surprisingly similar.

Blue Hill, Mass Daily Insolation Frequency Distributions Winter (15 Nov thru 14 Mar)

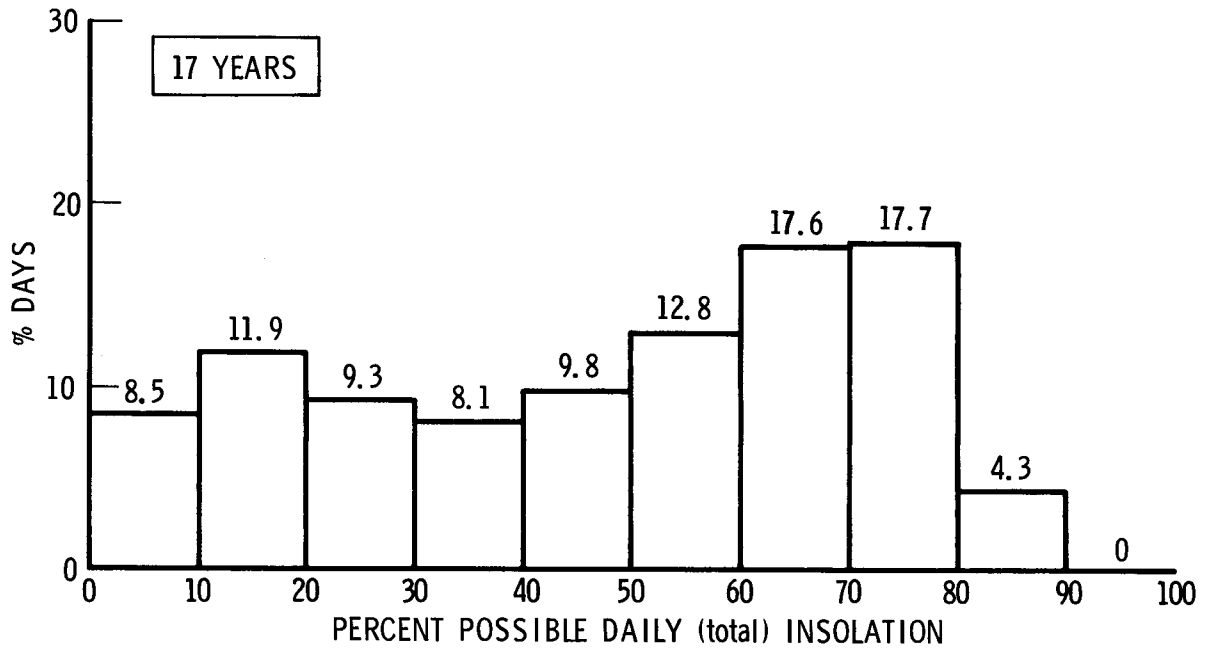

This histogram for Blue Hill, Massachusetts in the winter also exhibits the double-humped

characteristics. Almost 30% of the winter days have less than 30% possible insolation.

Omaha, Nebraska Daily Insolation Frequency Distribution Winter (15 Nov thru 14 Mar)

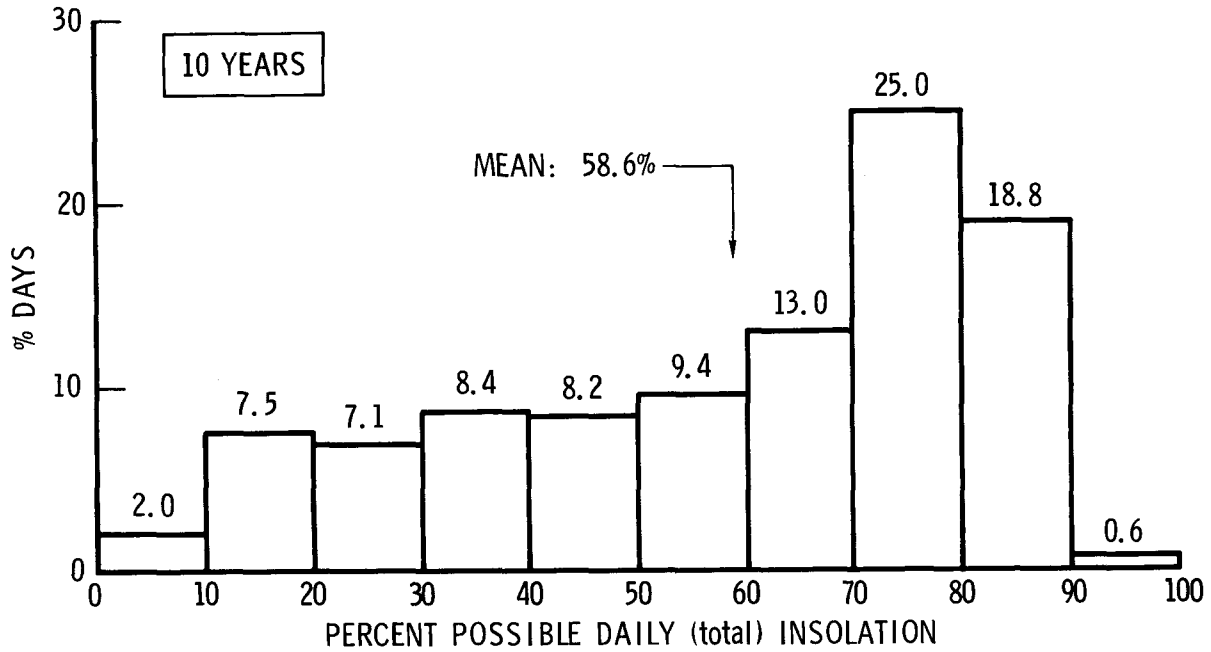

This histogram for Omaha in the winter based on 10 years of data is of interest in analyzing the

statistical performance of a typical liquid-medium collector described on the following three charts.

SHACOB

Requirements Definition and Impact Analysis

SAMPLE CASE: COLLECTOR STATISTICAL PERFORMANCE

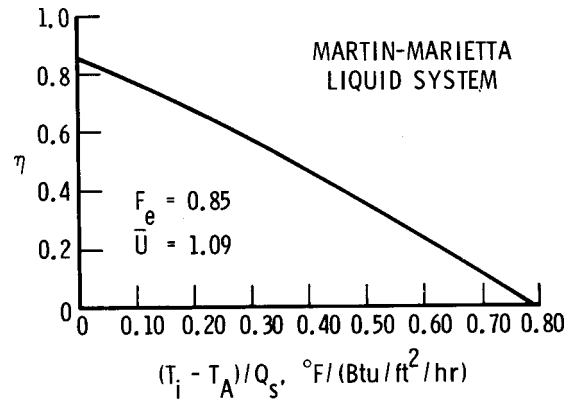
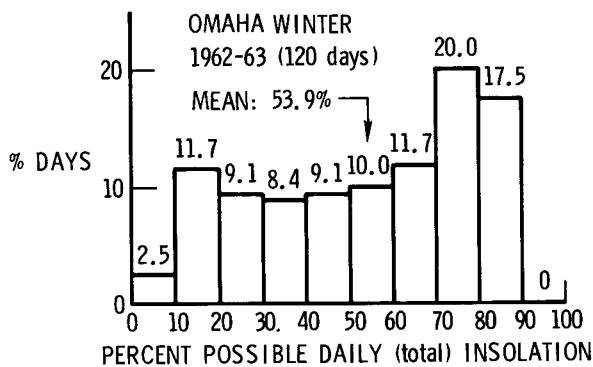

- HOURLY TEMPERATURE & TOTAL INSOLATION DATA (T_A and Q_s)
- LIU-JORDAN CORRECTION APPLIED TO HOURLY INSOLATION
- HOURLY SUN ANGLE CALCULATION, TILT = LAT + 15° = 56°
- INLET TEMPERATURE CONSTANT

● Here are outlined the conditions and assumptions associated with the calculation of the statistical performance of a high-efficiency liquid-medium collector developed by Martin-Marietta (M-M). It is sometimes instructive to break system performance into component parts, and in this instance, the question is regarding the daily frequency with which the collector will have very low output.

● The collector was driven by 120 days of hourly ambient temperature and insolation data for the winter of 1962-63 in Omaha. The daily insolation frequency distribution for this particular winter is seen to be fairly similar to the distribution just presented which was based on 10 years of data. However, this winter was on the average 8% darker (53.9% vs. 58.6%) than the average and 23.3% of the days were less than 30% possible insolation as opposed to 16.7% of the days based on the 10-year period. ● The M-M collector efficiency is shown (from their marketing literature)

as a function of inlet temperature and ambient temperature difference divided by the incident insolation. ● The incident insolation was calculated hourly for a near-optimum tilt angle of 56° (facing south), and the Liu-Jordan algorithm for calculating the direct and diffuse components of the total insolation was used along with a ground reflectivity of 0.2 into the tilted collector (corresponding to dark soil). ● It was assumed that the inlet temperature was constant throughout the 120 days of hourly data, and parametrically varied over the expected range. A full simulation of SHACOB/Loads operation would be required, of course, to generate the true inlet temperature as a function of time. A perfect system cutoff was assumed, however; when Δt (or Q_s) was such that the output temperature would be less than the inlet, the collector was turned off.

SHACOB

Requirements Definition and Impact Analysis

SAMPLE CASE: COLLECTOR STATISTICAL PERFORMANCE

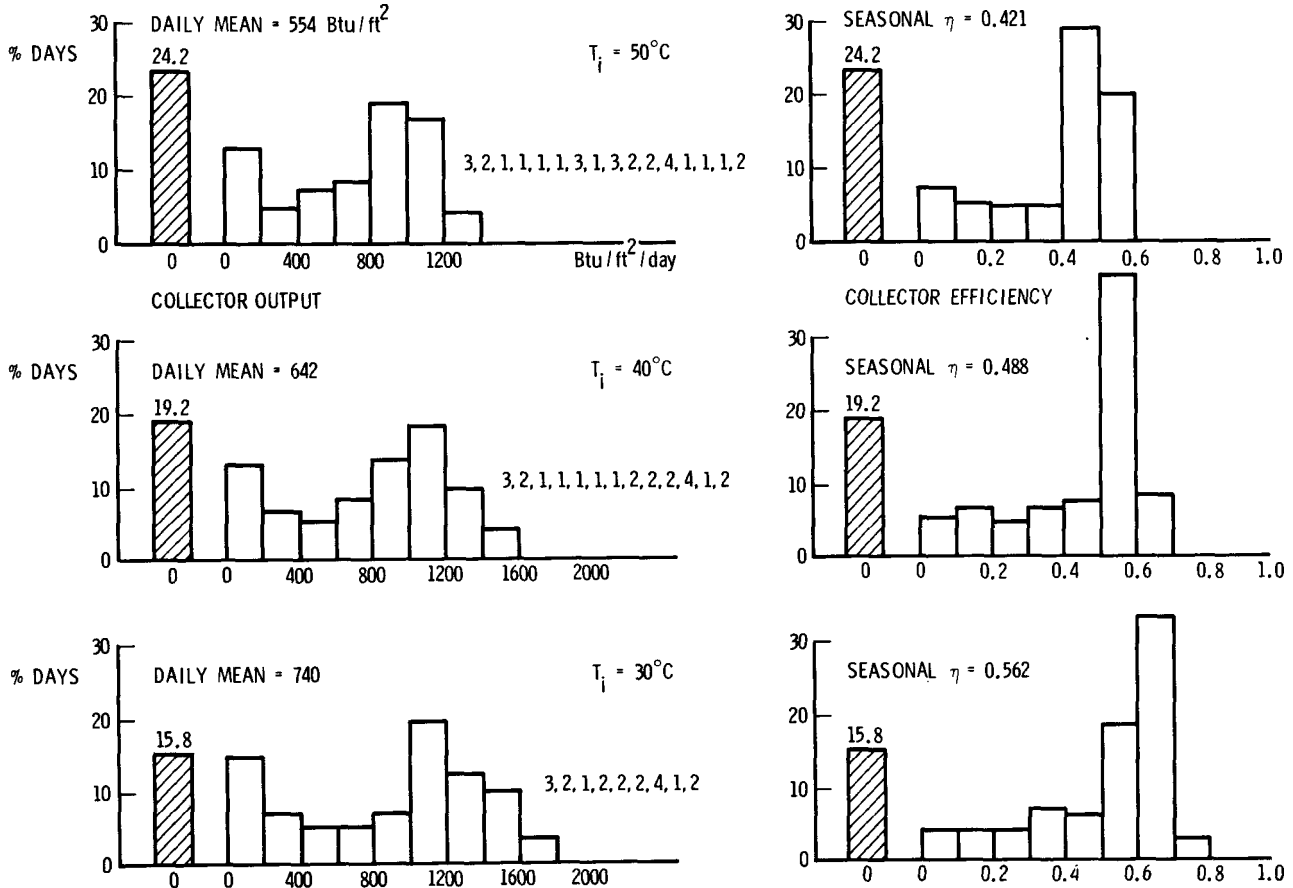

Although in some instances, inlet temperatures might exceed 50°C (122°F), this value is the high side of a reasonable range and 40°C (104°F) is the low side. The histograms show that on between 19 and 24% of the days, the collector output was exactly zero although the average output ranged from 642 to 554 Btu/ft²/day. The frequency function for $T_i = 30^\circ\text{C}$ (86°F) is also shown although this input temperature is on the low side for a liquid system. The histograms for daily efficiency are shown on the right; the seasonal efficiency is defined to be the total season output energy divided by the total season incident energy, not the first moment of the data

represented by the histogram which would be the average of the averages. The significance of the chart is that even for a high performance collector working at a good average efficiency, there is a large percentage of days for which the output is zero. The sequence (for $T_i = 50^\circ\text{C}$), 3, 2, 1, 1, 1, 1, 3, 1, 3, 2, 2, 4, 1, 1, 1, 2 is the groupings of the 29 days (24.2%) for which the output was zero. It is interesting to note that the one 4-day string of zero output persisted down to an inlet temperature of 30°C . All 29 zero-output days corresponded to insolation less than 40% possible, and 25 of the days corresponded to less than 30% possible.

Omaha, Nebraska

EXPECTED NUMBER OF SUCCESSIVE DAYS AT
LOW LEVELS OF INSOLATION

WINTER
(15 Nov thru 14 Mar)

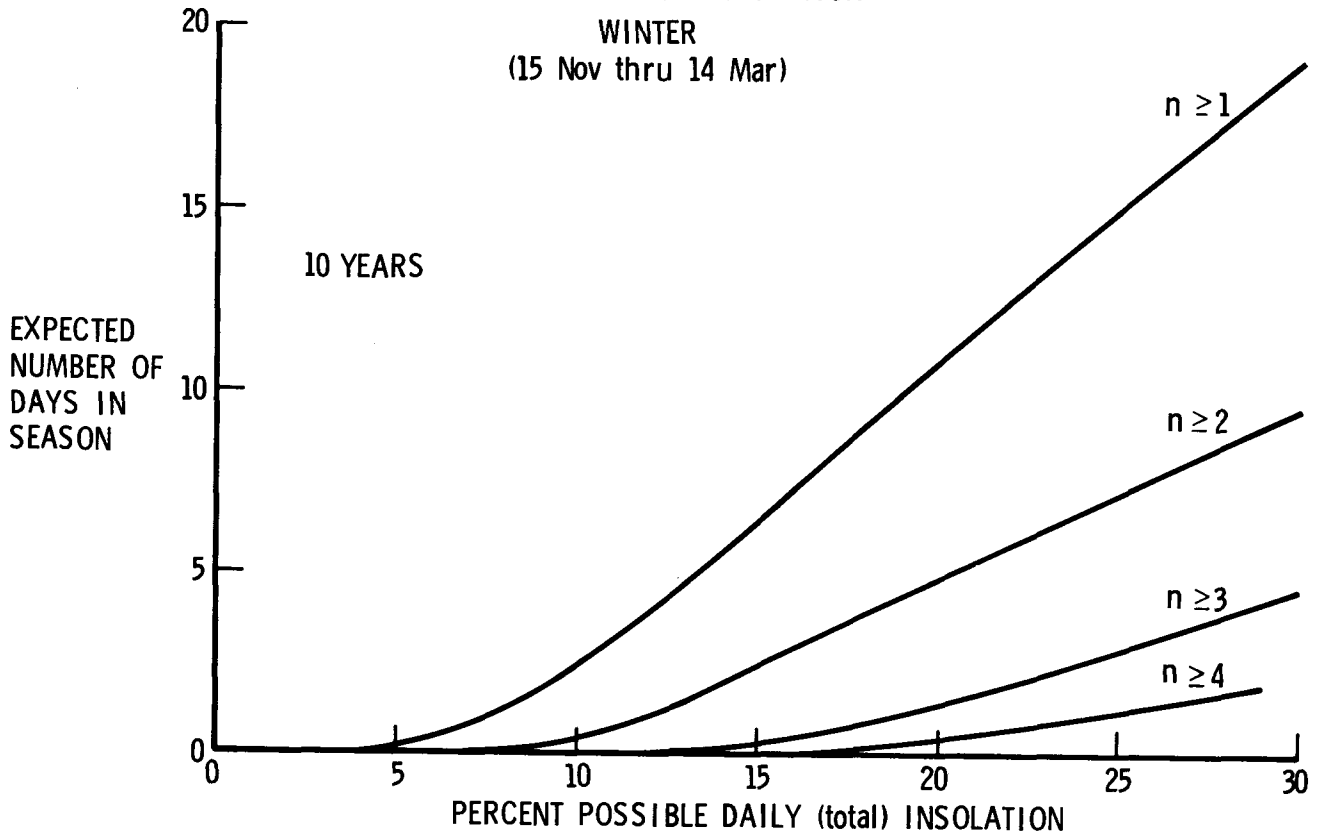

This is a plot of the persistence probabilities for Omaha in terms of expected numbers of successive days (rather than probabilities). The low-insolation tails are the main interest and are plotted here on an expanded scale for clarity. The plot shows that (based on 10 years of data), the expected number of days per year in adjacent-

day groups of 4 for which each day has less than 30% possible insolation is 2. That is, on the average, approximately a little less than 1 out of every 2 years has a sequence of 4 or more days with less than 30% insolation. Therefore, the 1962-63 winter is poorer than average, but also not very atypical.

SHACOB

Requirements Definition and Impact Analysis

ANALYSIS BLOCK DIAGRAM FOR DEMAND CALCULATIONS

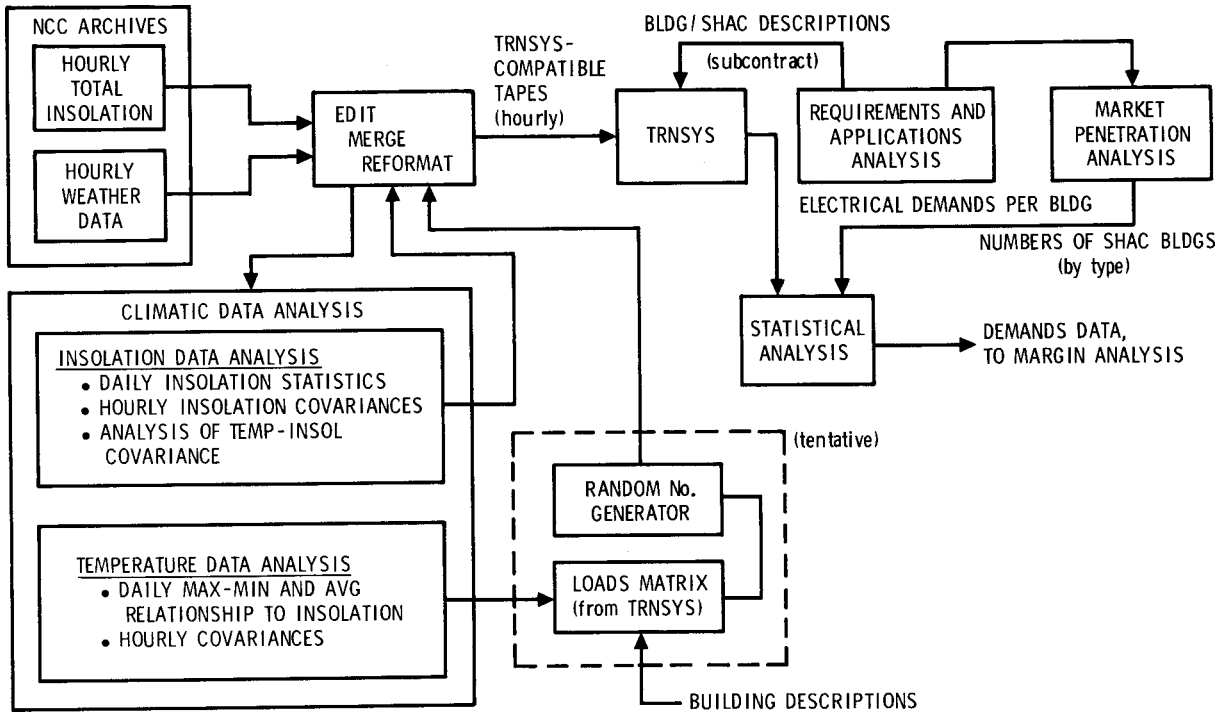

● This is an expanded diagram of the calculations and analysis for determining the statistics of the total utility makeup power required to support SHACOB systems. It should be put into the context of the preceding insolation and climatology data base discussion and subsequent to this, the presentation of TRNSYS (the SHACOB simulation obtained from the University of Wisconsin). ● The hourly climatic data are obtained from the National Climatic Center and some editing, reformatting, and merging are required to be compatible with TRNSYS. These hourly data will also be used in the analysis of daily insolation to see if there are analytical short cuts that can ease the burden of organizing, generating and maintaining numerous tapes of hourly input data for TRNSYS. The hourly data will be examined to see if the data do appear similar (statistically) for certain kinds of days (very bright, very dark, etc.) regardless of location. Hopefully, relationships will be established between hourly insolation and temperature data for different kinds of days as denoted by their daily percent possible insolation. Then, conclusions which are broadly applicable (geographically) can be drawn from a limited number of hourly simulations and an examination of the daily statistics for the location in question.

● An alternate route for speeding up loads calculations is shown based on a response matrix generated from linear differential equations representing the building thermal response. A covariance of temperature residuals about the vector of hourly means (for a day) would be combined with the response matrix to produce the covariance of hourly loads. A random number generator playing through matrices based on the loads covariance would then produce a random sequence of load variations with the proper statistics. This approach would be valid provided that the temperature residuals can be shown to be independent of insolation residuals when partitioned into various daily insolation levels. ● The TRNSYS program has to be fed with descriptive data for both buildings and SHACOBs that reflect the proper application of SHACOB and which are characteristic of the future. The TRNSYS simulation is run for each building, SHACOB system, and climatological region, one at a time. ● Market analysis and parametric studies will be used to generate expected levels of market penetration, i.e., expected totals of various kinds of buildings and systems. These totals summed appropriately among the various TRNSYS outputs will produce the total estimated utility makeup demand.

SHACOB

Requirements Definition and Impact Analysis

TRNSYS CODE

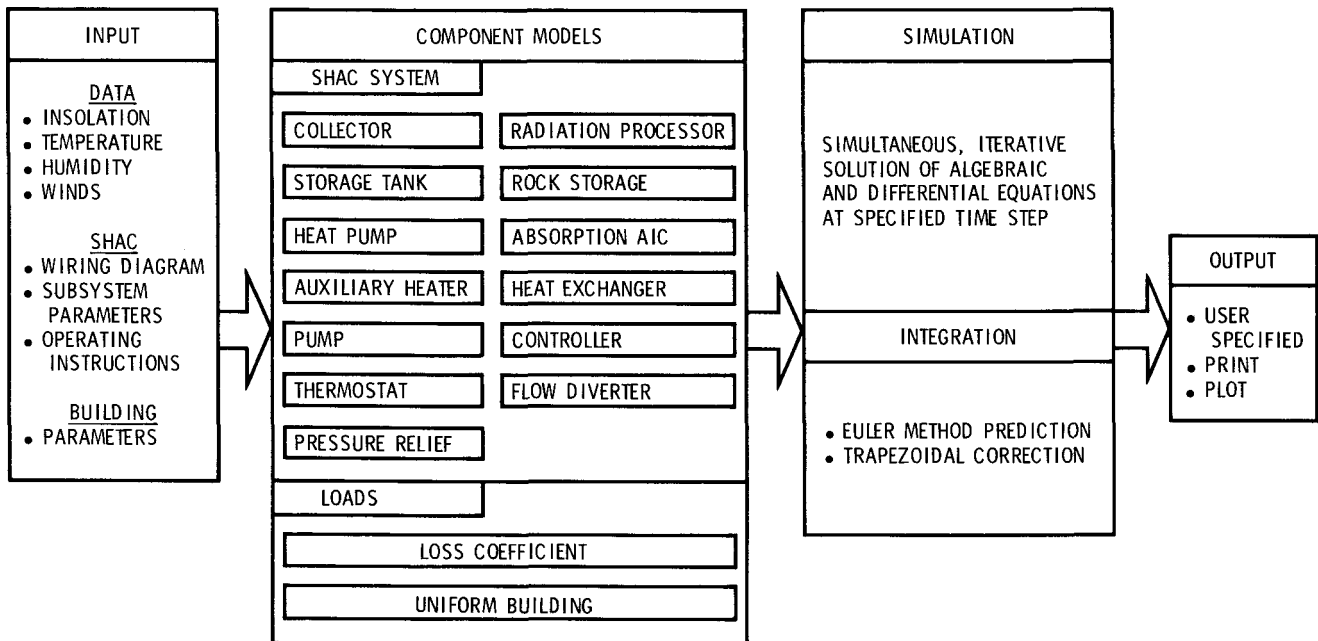

The TRNSYS program simulates the dynamic behavior of solar heating and cooling systems. It is based on a modular approach which enables the user to readily simulate a wide variety of systems. The program consists of the various component models shown and an executive routine. Input consists of climatological data, SHAC parameters and loads calculation parameters. The component models are connected by a code "wiring diagram" analogous to the physical interconnections. A simulated SHAC

system can consist of any physically reasonable combination of the 13 component models. A given component may be used several times in a system as long as the total number of components is less than 50. The differential and algebraic system equations are solved iteratively through predictor/corrector integration. Output consists of any system variables (or their integrals desired by the user).

SHACOB

Requirements Definition and Impact Analysis

A TRNSYS MODEL SHAC CONFIGURATION

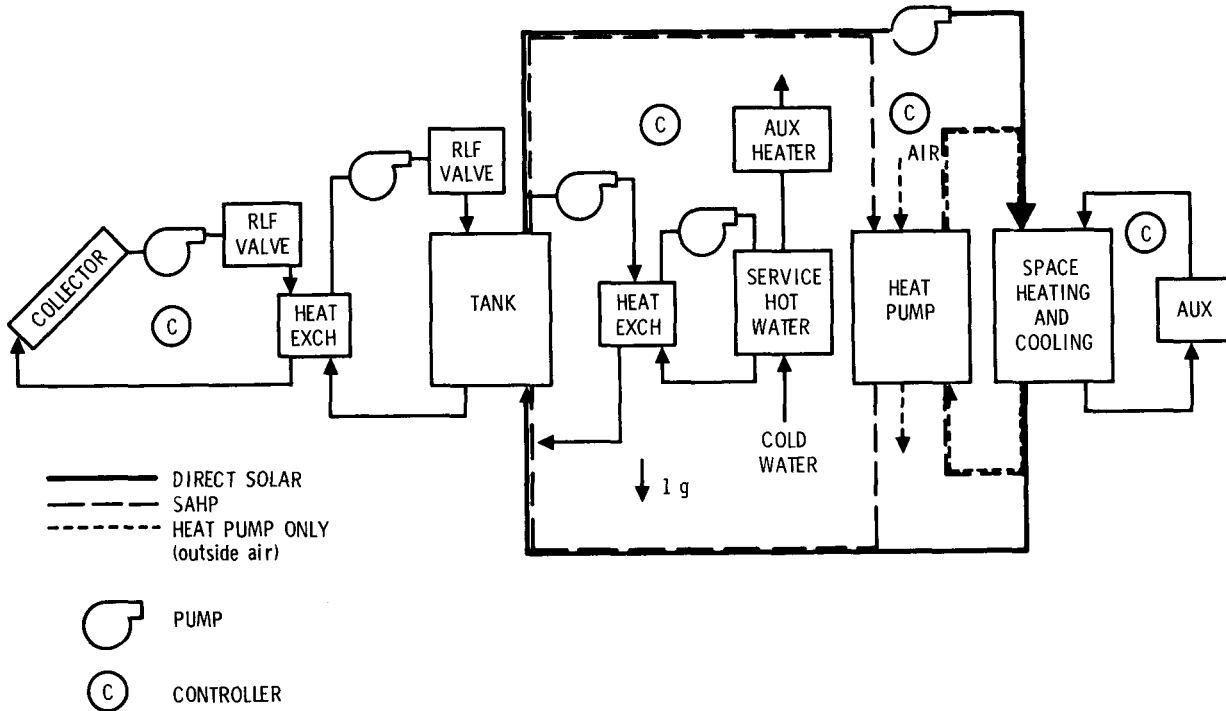

The SHAC system shown typifies the level of complexity that can be simulated with TRNSYS. In this configuration all heat transfer occurs through heat exchangers (for the heat pump and space heating and cooling component models the heat exchangers are internal). Pressure relief valves keep fluids below the boiling point. A service hot water tank separated from the main storage tank permits a closed system for collector/storage operations. The heat source

for the heat pump can be either the outside air or the storage fluid, whichever is at the higher temperature. If direct heating from the storage tank is possible, the heat pump is bypassed. When this solar-assisted heat pump system is unable to meet the load, the required makeup is provided by the auxiliary energy source. Throughout the system controllers switch components in and out as functions of temperature.

SHACOB Requirements Definition and Impact Analysis

LOADS CALCULATION OPTIONS

MODEL	CHARACTERISTICS	ADVANTAGES	DISADVANTAGES
LOSS COEFFICIENT	<ul style="list-style-type: none"> • $Q_L = UA (T_R - T_A)$ • INTERNAL LOADS 	<ul style="list-style-type: none"> • FAST SIMULATION • EASY TO PARAMETERIZE • BEST ACCURACY WITH LOW TEMPERATURE VARIATION 	<ul style="list-style-type: none"> • NO THERMAL INERTIA • NO SOLAR RADIATION EFFECTS • DIFFICULT TO SELECT PROPER UA
UNIFORM BUILDING	<ul style="list-style-type: none"> • FOUR WALLS • ROOF AND ATTIC • BASEMENT • SOLAR RADIATION • SHADING • THERMAL INERTIA • INTERNAL LOADS 	<ul style="list-style-type: none"> • MODERATE ACCURACY UNDER ALL CONDITIONS 	<ul style="list-style-type: none"> • MODERATE SIMULATION TIMES • DIFFICULT TO PARAMETERIZE
NBSLD	<ul style="list-style-type: none"> • ROOM BY ROOM MODELING • SOLAR RADIATION • SHADING • THERMAL INERTIA • INTERNAL LOADS 	<ul style="list-style-type: none"> • ACCURATE LOADS UNDER ALL CONDITIONS 	<ul style="list-style-type: none"> • SLOW SIMULATION • MANY INPUTS REQUIRED • DIFFICULT TO PARAMETERIZE

The current options for computing heating and cooling loads for SHAC simulations are the TRNSYS loss coefficient model, the TRNSYS uniform building model, and the NBSLD loads program listed in order of increasing accuracy and complexity. The loss coefficient model requires negligible computer time and readily lends itself to parameterized studies. (This requires the selection of representative loss coefficients.) It does not account for solar radiation and thermal inertia effects as the other two options do. Direct solar radiation effects could be included with little penalty and, as long as temperature variations

are not too great, actual thermal inertia effects should be small. The uniform building consists of four walls, sloping roof, attic and basement. Loads accuracy increases at the expense of computer time and the number of parameters involved. The NBSLD house permits a room-by-room description producing accurate load predictions. However, the program is expensive to run and particularly difficult to parameterize. For the present study a large number of buildings must be considered and therefore running time and ease of parameterization are critical. The higher accuracy models will serve mainly to validate simplified models.

SHACOB

Requirements Definition and Impact Analysis

TRNSYS SAMPLE CASE

1. INSOLATION

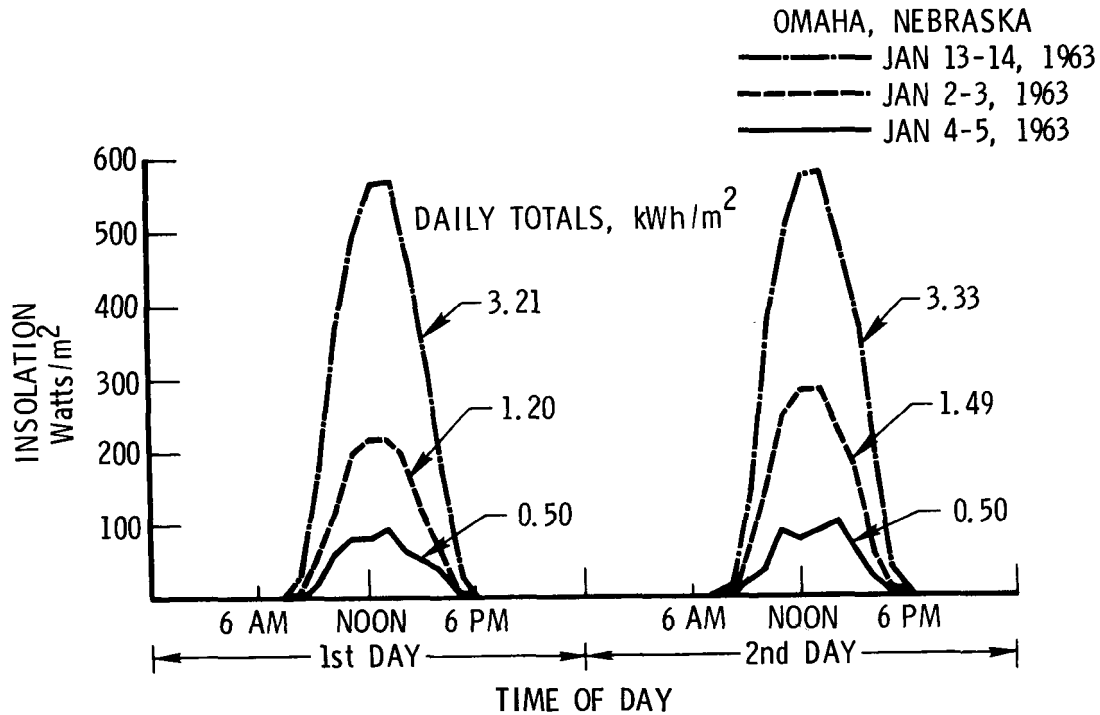

A sample TRNSYS simulation case is presented for the month of January 1963 in Omaha, Nebraska. The three 2-day periods shown are illustrative of high,

moderate, and low insolation levels on a horizontal flat plate (daily averages of 86, 38, and 14% possible, respectively).

SHACOB Requirements Definition and Impact Analysis

TRNSYS SAMPLE CASE

2. TEMPERATURE

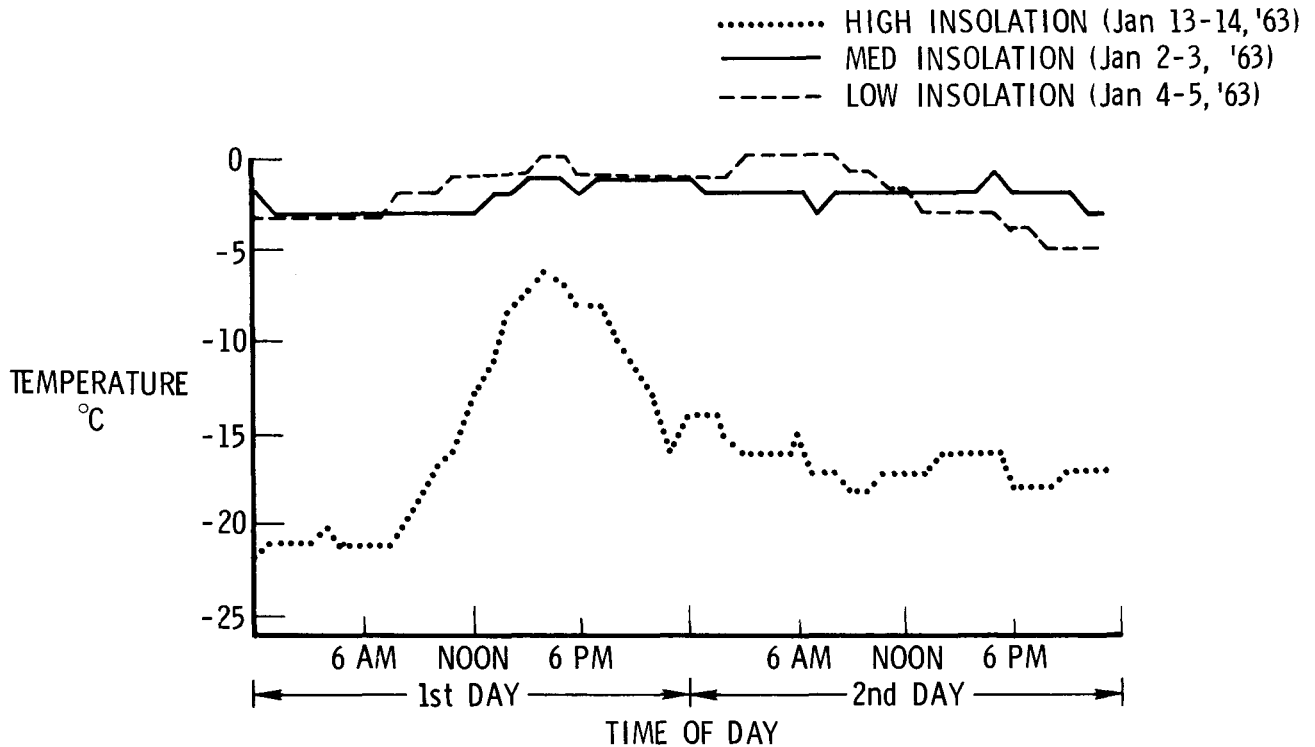

During the three 2-day periods depicted, the outside temperatures never exceeded freezing. During the period of high insolation (i.e., clear days) the temperature swing was fairly large.

For the periods of moderate to low insolation, i.e., cloudy days, outside temperatures were relatively constant.

SHACOB

Requirements Definition and Impact Analysis

TRNSYS SAMPLE CASE 3. BUILDING MODELS

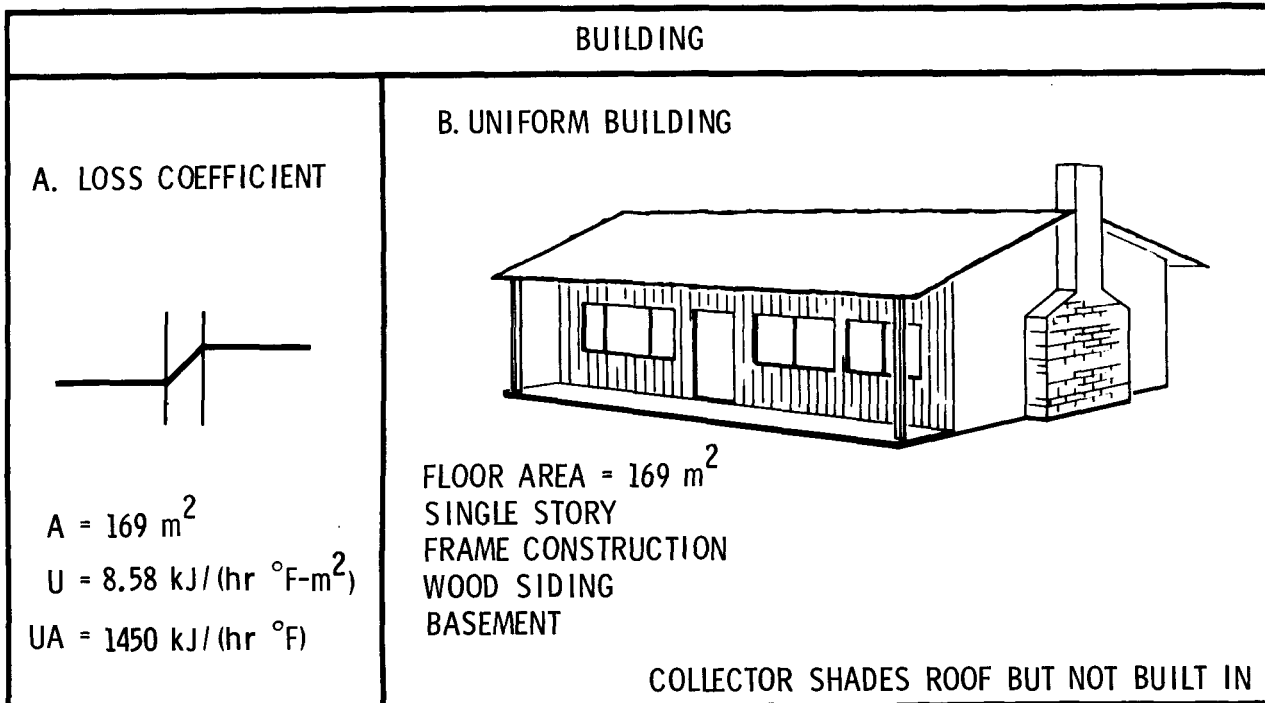

The single-story building selected for analysis was 169 m^2 ($\approx 1800 \text{ sq ft}$) in floor area with a double sloped roof, and a basement. The uniform building model takes into account the heat transfer through all exterior surfaces including the effects of solar radiation. A constant interior temperature of 21°C was assumed.

The loss of coefficient parameter UA was selected to give the same integrated total heating load as the uniform building model resulting in $UA = 1450 \text{ kJ}/(\text{hr}^\circ\text{F})$. In both cases a constant internal heat load (people and appliances) of 3500 kJ/hr was assumed.

SHACOB

Requirements Definition and Impact Analysis

TRNSYS SAMPLE CASE
4. HEATING LOADS

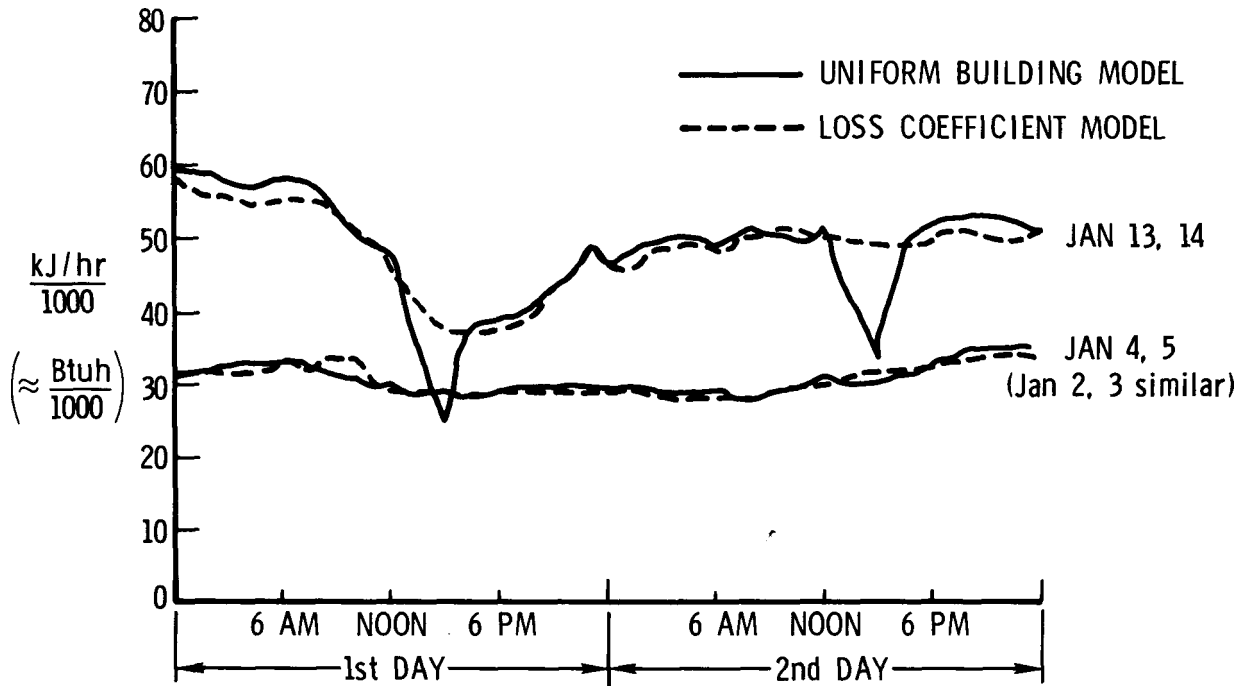

Heating loads were generated for the period of interest using both a loss coefficient and a uniform building model. In either case the loads followed the temperature variations approximately. However, the uniform building model accounted for solar radiation effects both direct (e.g., through

windows) and indirect (e.g., through thermal storage in the walls). The former effect is evidenced markedly in the early afternoons for the high insolation cases. Thermal storage effects appeared small.

SHACOB

Requirements Definition and Impact Analysis

TRNSYS SAMPLE CASE 5. SHAC SYSTEM CONFIGURATION

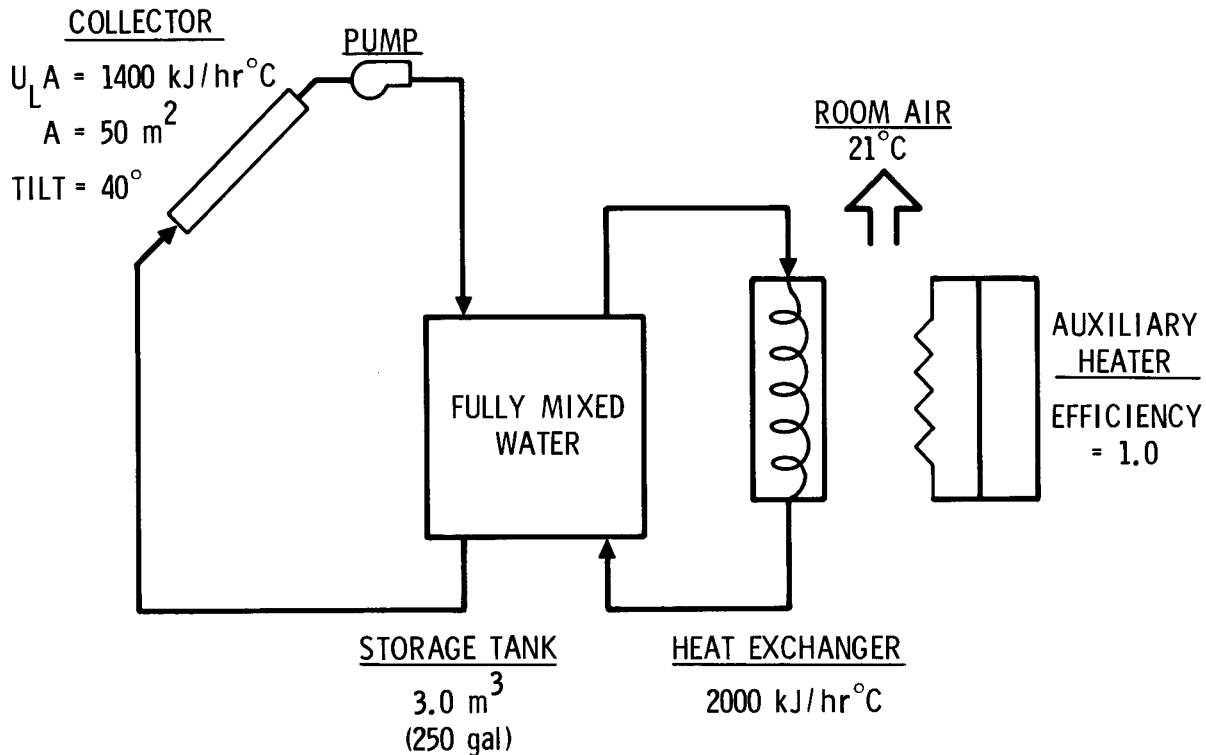

The sample SHAC system analyzed consists of a collector, collector pump, storage tank, a heat exchanger, and an auxiliary heater. Water is the working fluid throughout the SHAC system. The collector is tilted at 40° (optimum for year-round SHAC), has an area equal to 30% of the house floor area, and a loss coefficient of

$28 \text{ kJ}/(\text{hr}\cdot\text{m}^2\cdot^\circ\text{C})$. The fully mixed storage tank holds 250 gallons of water. The heat exchanger delivers $2000 \text{ kJ}/(\text{hr}\cdot^\circ\text{C})$ to room air assumed to be a constant 21°C . When the energy rate available through the heat exchanger fed by storage is insufficient to meet the house heating load, the auxiliary system supplies the difference.

SHACOB

Requirements Definition and Impact Analysis

TRNSYS SAMPLE CASE
6. SYSTEM PERFORMANCE
JAN 13, 14, 1963

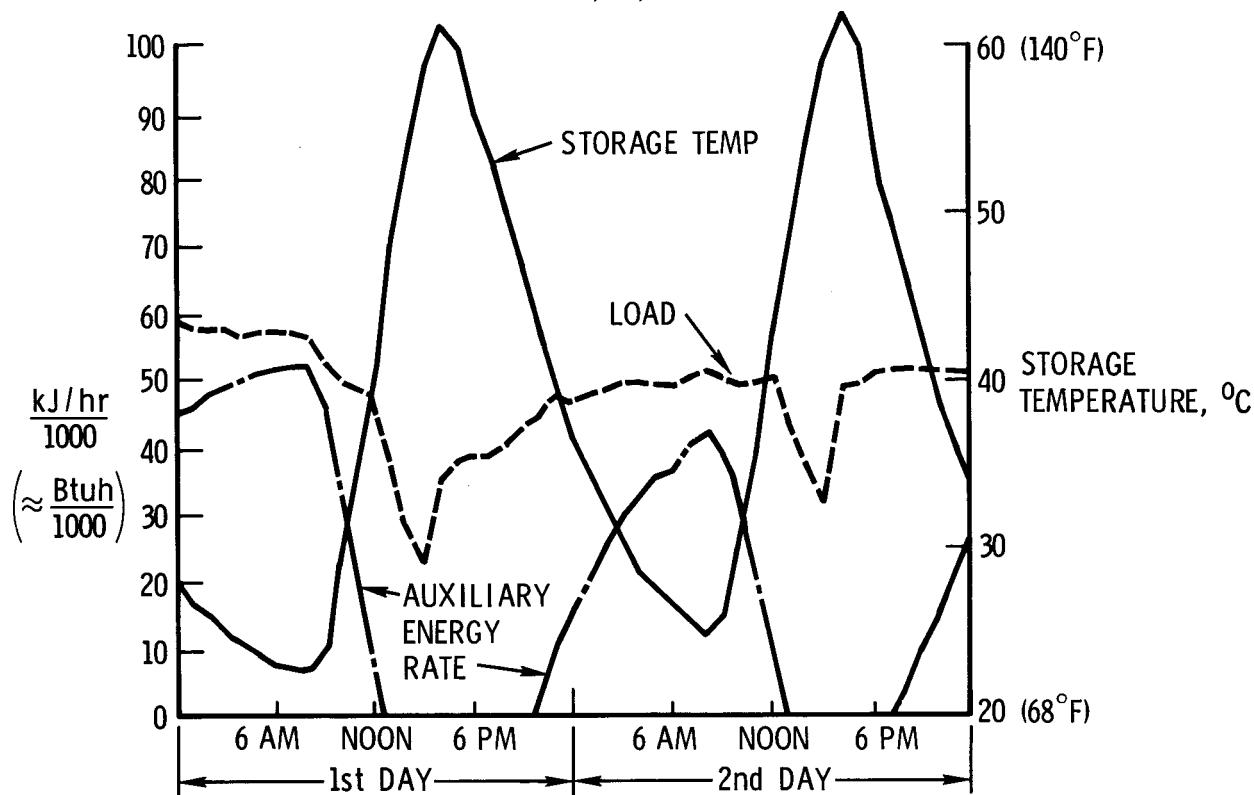

The performance of the SHAC/house/auxiliary system is depicted for the 2-day period of high insolation. During the afternoon and evening the auxiliary energy rate dropped to zero and

storage temperature reached a peak of 62°C. The large excursion in storage temperature was due to the relatively small storage tank (250 gallons) selected.

SHACOB

Requirements Definition and Impact Analysis

TRNSYS SAMPLE CASE 7. AUXILIARY ENERGY REQUIREMENTS

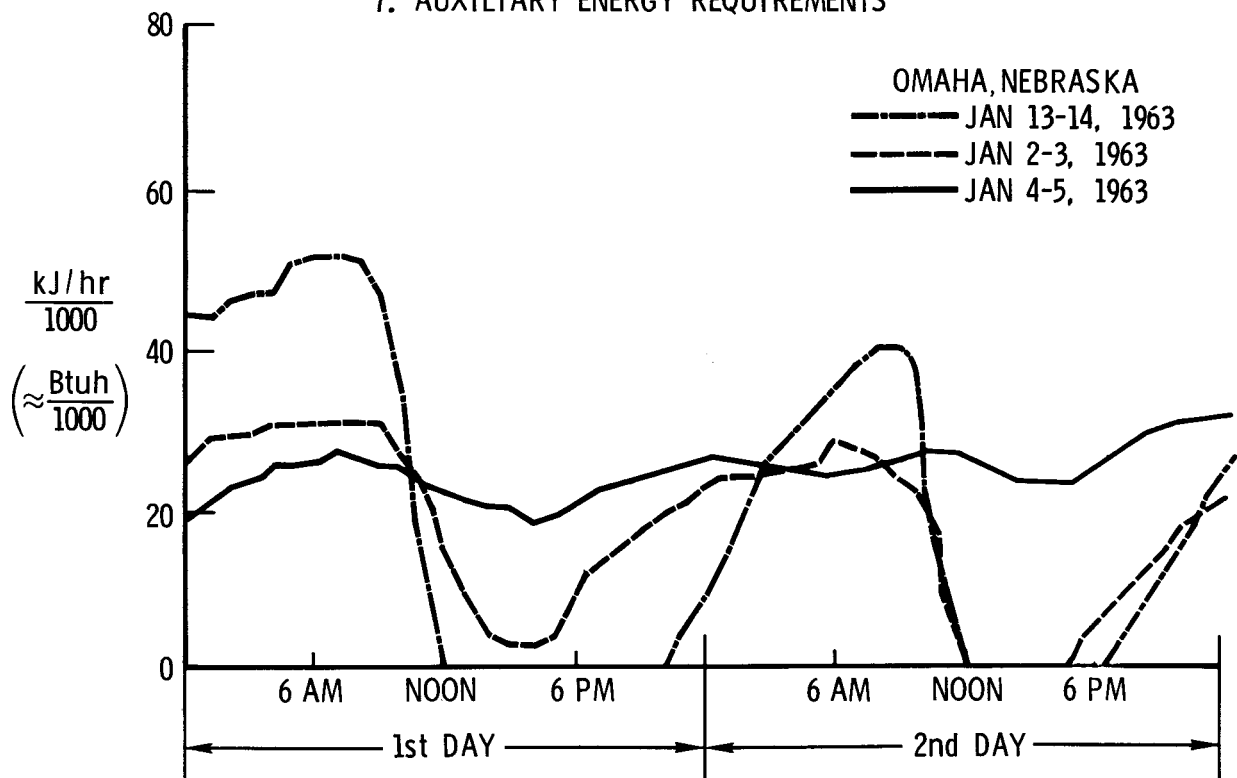

The rate at which the auxiliary or backup heating system augments solar energy to meet the house load is shown. During the high insolation/wide temperature swing days, the required auxiliary rate was high during the very cold nights but dropped off to zero from noon to late evening due to the availability of ample solar energy. For

the lower insolation cases, in which temperature did not vary widely, there was less variation in required auxiliary energy rate and for the lowest insolation case the solar energy supplied was insufficient to meet the demand at any time during the 2-day period.

SHACOB

Requirements Definition and Impact Analysis

TRNSYS COMPUTER RUN COSTS

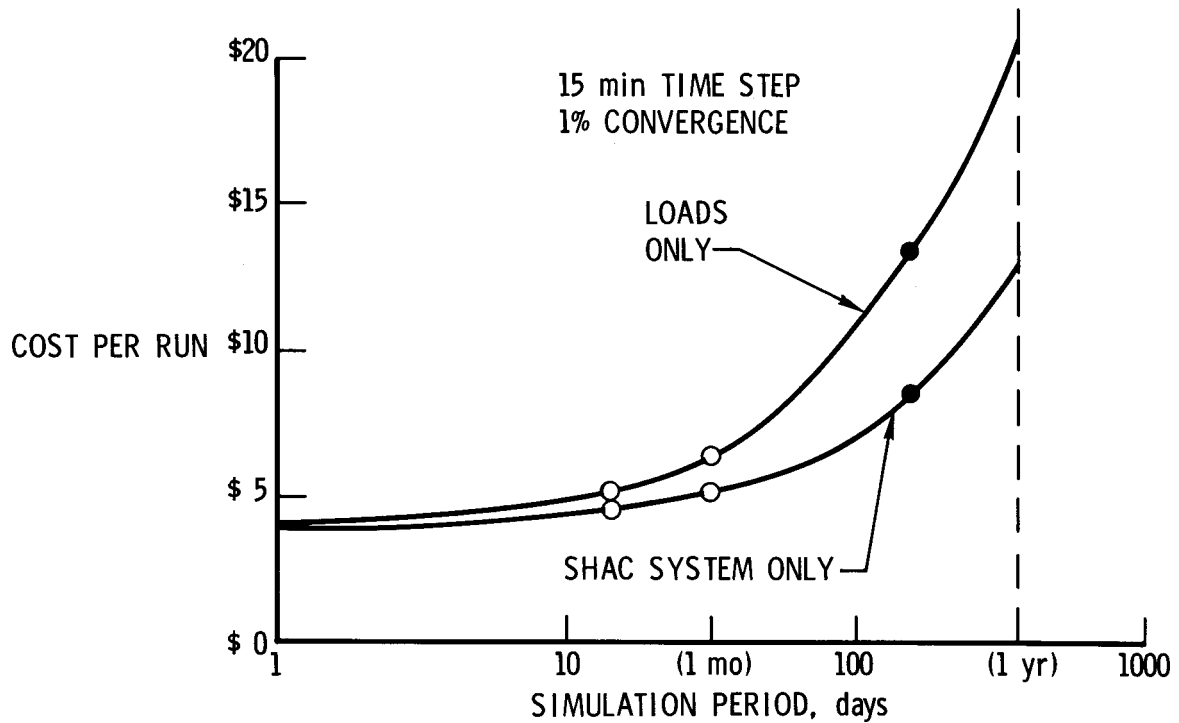

The cost of a computer run includes charges for input/output handling which are not necessarily proportional to the simulation period. Use of TRNSYS recommended values of time step and tolerances results in costs for a 1-year simulation of

about \$12 for the SHAC system alone and \$20 for the uniform building loads alone for a total of \$32. If the loss coefficient model is used, the total is essentially the same as the SHAC system alone.

SHACOB

Requirements Definition and Impact Analysis

TRNSYS COMPUTING COST REDUCTION APPROACHES

- OPERATIONS
 - INCREASE INTEGRATION TIME STEP
 - INCREASE ERROR TOLERANCES

- CODE AND MODELS
 - IMPROVED INTEGRATION ALGORITHMS
 - DELETION OF MODEL REFINEMENTS
 - DELETION OF CERTAIN LOOPS AND ITERATIONS

- SIMULATION
 - SIMPLIFIED LOADS CALCULATIONS
 - SELECTED TIME PERIODS

The large number of cases that must be simulated for this study requires that the cost per TRNSYS simulation be reduced significantly. Several approaches will be taken to accomplish this.

- Increasing the integration time step from the nominal 0.25 hr to 0.50 or 1.0 hr will provide proportional reductions in computing time, if error tolerances are appropriately increased. The effect of step size and error tolerances on computational stability is currently under investigation.
- It is possible that somewhat more sophis-

ticated integration algorithms could actually decrease running time by improving computation stability. Code modifications that delete unnecessary model refinements and options and unnecessary loops and iterations will definitely reduce running time.

- The more simplified loads calculation models (particularly the loss coefficient model) should be sufficient for much of the analysis. Finally, a judicious selection of statistically representative simulation periods within the total span of interest may be possible.

SHACOB

Requirements Definition and Impact Analysis

IMMEDIATE OBJECTIVES
(15 August 1976)

- COMPLETE INSOLATION/WEATHER DATA BASE & RELATED ANALYSES
- FINALIZE DEMAND DATA STATISTICAL APPROACH
- FINALIZE SIMULATIONS
 - SPEED UP TRNSYS
 - INSTALL & CHECKOUT NBS LOADS PROGRAM
 - DEVELOP STATISTICAL ANALYSIS PROGRAM
- DEVELOP BASELINE DESIGNS (W/subcontractor)
 - 40 NOMINAL BUILDINGS
 - SEVERAL VIABLE SHACOBS PER BLDG -- ELIMINATE LOSERS
 - DEFINE PARAMETRIC STUDIES

● Aerospace will have its insolation-temperature-relative humidity data base and related analyses completed by August. ● These analyses plus the design of the statistics routine mentioned below will point to the kind of statistical description of demand data required from the utilities. As a minimum, hourly demand variations about the hourly mean (for a given season) in terms of a covariance will be required. We may want to partition the raw data according to daily weather and insolation data and then generate distinct covariance for each type of day. Initially, we will work with the raw data in the Aerospace data bank. It is planned to have the statistical approach formulated by August, although it is not expected that (nor any need to have) the statis-

tics will be completed until around the end of the year. ● We are very close to having TRNSYS fully operational at this time and don't expect trouble with the NBS program, either. However, a subroutine for automatically summarizing the makeup energy statistics must be developed. ● We plan to go out on subcontract to an organization which is familiar with SHACOB engineering and installation to generate a baseline complement of buildings and SHACOB systems for those buildings. The definition of the building/SHACOB systems will be generated in terms of TRNSYS inputs. Although we had originally planned to complete that work by 1 October we are going to try to expedite so that the information can be presented at the next Semi-Annual Workshop in August.

EPRI CONTRACT RP549-1

INDIVIDUAL LOAD CENTER -
SOLAR HEATING AND COOLING
RESIDENTIAL PROJECT

CONTRACTOR

ARTHUR D. LITTLE, INC.
20 ACORN PARK
CAMBRIDGE, MASS. 02140

PROGRAM MANAGER

DAN NATHANSON
(617) 864-5770 XT 873

MARCH 1976
EPRI SOLAR REVIEW MEETING #1

SUMMARY - Overview of the Program

Arthur D. Little, Inc. is performing an 11-month system definition study for the Electric Power Research Institute to identify preferred solar heating and cooling systems which are compatible with electric utilities. Preferred systems are those that address the problems of managing energy resources in addition to displacing them.

The overall EPRI Residential Solar Heating and Cooling Project is planned for three phases:

Phase 0 - System definition study to determine preferred system functions and concepts for residential solar heating and cooling applications in two regions of the U.S.

Phase 1 - Detail design of residential experiments, 5 in the Northeast and 5 in the Southwest.

Phase 2 - Construction, test and evaluation of the ten experiments.

This presentation deals with the Phase 0 effort which was initiated July 1, 1975. The effort calls for the development of a methodology to relate solar system and utility considerations, performance studies using a computer simulation and development of preliminary designs of SHAC/Load Management systems suitable for ten residential dwellings in areas serviced by two utility partners, the Long Island Lighting Company and the Public Service Company of New Mexico. Also, the methodology will be exercised for fourteen additional utility service areas to test its generality when utilized under a diverse set of circumstances.

FIGURE 1
ELEMENTS OF PHASE 0 PROGRAM

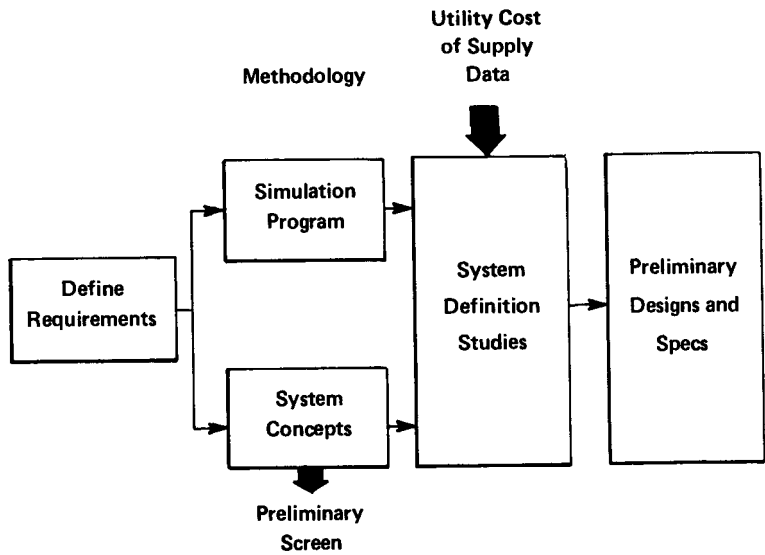

FIGURE 1
ELEMENTS OF PHASE 0 PROGRAM

In the first part of the program the loads of the SHAC Systems and the interfaces with the utility systems were defined. The development of the methodology involved a computer simulation program capable of describing the various types of SHAC systems, load management options, building loads, and utility input data. Simultaneously, matrices of systems concepts were prepared to account for various SHAC functions and configurations and load management options.

Since the number of systems was very large they were passed through a preliminary screen to truncate the matrices. This screening resulted in a smaller set of surviving systems which were suitable for refined computer studies incorporating utility input data.

The remaining effort involves preparation of test plans, preliminary designs and preliminary specifications for five experimental SHAC systems for the Northeast and five for the West/Southwest.

FIGURE 2

GENERAL QUESTION

Which SHAC Systems Would Be Preferred
By Utilities And Consumers Considering:

- Costs of Electrical Supply
- HVAC Loads
- SHAC And Load Management Options
- Equipment Costs And Availability
- New Construction

FIGURE 2

GENERAL QUESTION

Conventional HVAC or SHAC/Load Management Systems in all-electric residences can potentially interact with electric utility operations and impact such things as base load (load factor), requirements for new generation investment, and requirements for spinning reserve. The impacts on an electrical utility can be positive or negative depending upon the characteristics of the particular utility and the design of the particular HVAC system in the residence.

An important part of the Phase 0 systems definition effort concerns the development of a methodology which can be incorporated in a computer program and relate the requirements of both the SHAC systems and the utility to answer the stated question. It should be emphasized the cost of electric supply for the particular utility service area is of prime importance and is emphasized in the overall methodology.

FIGURE 3
OVERALL DESIGN APPROACH
FOR PREFERRED SYSTEMS

- **Building Energy Conservation**
- **Shifts In Electric Energy Demand**
- **Solar Displacement of Energy Resources**

FIGURE 3
OVERALL DESIGN APPROACH FOR PREFERRED SYSTEMS

While the study is intended to develop a methodology for determining preferred SHAC systems, in particular utility service areas, it recognizes that the overall building and system design process must take account of three options:

- 1) Reducing building loads by the use of cost-effective insulation practices.
- 2) Reducing costs by shifting the pattern of electrical power demands made on the utility system.
- 3) Displacement of energy resources by installation of solar heating and cooling systems.

FIGURE 4
HVAC SYSTEMS CONSIDERED FOR
ALL ELECTRIC RESIDENCES

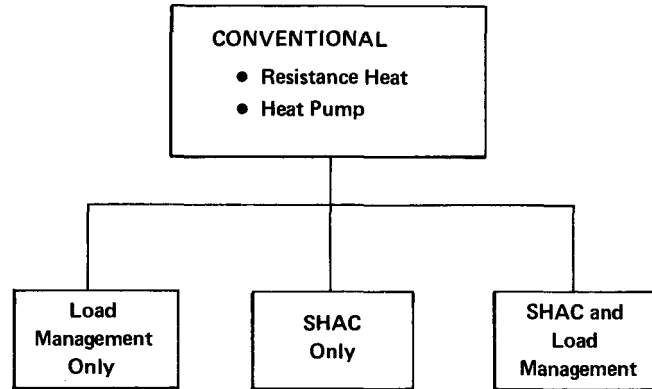

FIGURE 4
HVAC SYSTEMS CONSIDERED FOR
ALL ELECTRIC RESIDENCES

The study takes account of at least four basic generic classes of HVAC systems which apply to all-electric, single family residences. The conventional HVAC system is what would be commonly used or envisaged in the future in the absence of load management or solar supplement. In the conventional case, space heating could be provided by electric resistance heat or by a heat pump. Systems based on making incremental changes to the conventional system could be as follows:

- a) Conventional with the addition of Load Management, such as a thermal storage tank and an off-peak heater integrated with the space heating system (Load Management Only).
- b) A solar system installed to displace electrical energy, but having no provisions for electrical load management (SHAC ONLY).
- c) A solar system installed to not only displace, but also shift usage of electric energy (SHAC & Load Management).

FIGURE 5

UTILITY INFLUENCES ON PREFERRED SYSTEMS

		Average Cost of Electrical Supply	
		Low	High
Time of Day Cost Variation	Small	Conventional	SHAC Only
	Large	Load Management Only	SHAC and Load Management

FIGURE 5

UTILITY INFLUENCES ON PREFERRED SYSTEMS

It is often convenient to think of justifying a SHAC system on the basis that its incremental additional capital cost is offset by the annual cost savings of the energy resources it displaces over the system's lifetime. The higher the cost of the displaced energy source, the more acceptable it is. If the energy cost is very low, there will be little potential for cash flows (annual cost savings) to justify the SHAC system. For load management, cost savings or cash flows can be achieved by shifting electrical usage from a time of day when the cost of supply is high (e.g., during a peak period) to an off-peak period when the cost of supply is low. The larger the differential between cost of supply at peak and off-peak operating periods or the larger the time-of-day variation in cost of supply, the easier it is to justify the incremental capital cost of a load management system (thermal storage, controls, etc.). If the time-of-day variation in cost of supply is small, potential for load management cost savings will be too small to justify equipment costs.

The simplified chart summarizes some of the utility influences on preferred systems under bounded or limiting situations. If a utility average cost of supply is low and the time-of-day cost variation is small, it will be difficult to justify any departures from a conventional system for either SHAC or load management. A high cost of supply combined with a small daily variation would help justify consideration of a SHAC-only system, but there would be little incentive for a load management function. A low average cost of supply, but a large daily variation, would favor consideration of a load management function, but not a SHAC system. Finally, the combination of a high average cost of supply and a large daily cost variation would justify consideration of both SHAC and load management systems.

FIGURE 6
INFORMATION RELATED TO
UTILITY SERVICE AREA

- **Generation (Fuel) Costs Vs. Demand**
- **Total System Load Profiles Vs. Time**
- **Other Supply and Capacity Costs**
- **Rate Schedules**
- **Non-HVAC Residential Electric Demand**

FIGURE 6
INFORMATION RELATED TO UTILITY SERVICE AREA

An accurate determination of preferred systems must take account of the components in the cost of supply in a particular service area. A general form of the utility input data has been developed based on the project objectives and discussions with representatives of the two utility partners, Long Island Lighting Company of Mineola, New York, and the Public Service Company of New Mexico, Albuquerque. The intent was to make the form of the inputs general, include flexibility by allowing several approaches to specifying cost-type information, and to be consistent with information that was available or could be furnished by the electric utilities. A brief summary of the information required related to the particular utility service area is outlined below.

- A. Generation (Fuel) Costs. The fuel cost per kWhr is computed from two types of information supplied by the utility:
- (1) Total System Electrical Demand vs. Time, where the time variable considers time of day, weekday or weekend, month or season, and year. An optional provision is included to specify influence coefficients which can modify the "weather-insensitive" value of the total system load in the summer months and in the winter months.
 - (2) Electrical Generation Costs vs. Demand, which defines fuel cost in mills/kWhr versus total system demand (MW), and can be specified as being seasonally or monthly dependent. This information reflects the performance of the mix of units expected to be on line to meet a level total system demand and the particular fuels used to fire the units.

The combination of the knowledge of total system load versus time and the generation costs versus total system load provides information that the computer uses to calculate the fuel cost per kWhr that should be applied to the SHAC system at the instant electric power is demanded (As discussed below it may be appropriate for some utilities to add a fixed cost per kWhr to the fuel cost.)
- B. Additional Cost Elements, Primarily Related to Fixed Costs. The following options have been provided to express fixed supply costs. A single option or a combination of options may be used to allocate the fixed costs as appropriate to the particular utility.
- (1) A Monthly System Peak Load Cost Expressed in \$/kW. This cost is allocated on the basis of the residence HVAC electric demand at the hour during each month that the total utility system experiences a peak.
 - (2) A Fixed Cost Expressed in Mills per kWhr. This may be specified as one value or designated according to month or season.
 - (3) A Fixed Customer Cost per Month. This cost is appropriate only when the total cost of supply, including non-HVAC electrical costs, is to be computed.

In addition to the inputs provided to compute cost of supply, inputs can be made for parametric variations in rate structures. This allows the total annual cost of supply to be compared with the annual revenues, and the comparison to be provided with a particular rate structure.

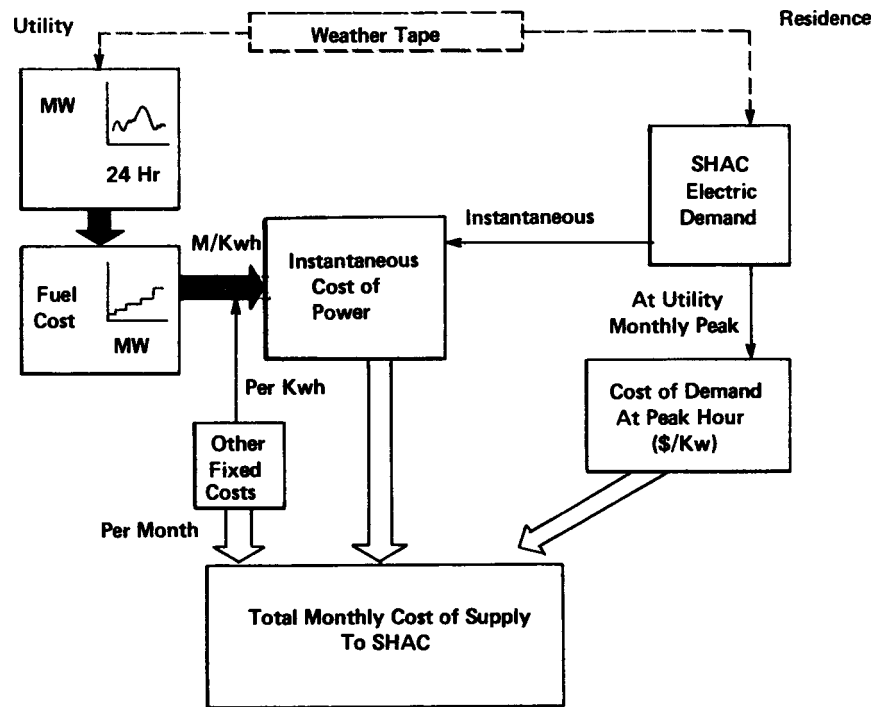

COST OF SUPPLY COMPUTATION

FIGURE 7

FIGURE 7

COST OF SUPPLY COMPUTATION

This flow chart illustrates the computation procedure followed by the computer simulation program, which lists as one of its outputs a monthly summation of the cost of electrical supply provided to the SHAC residence. It should be noted that the weather tape parameters not only have an impact on the HVAC loads on the residence, but also can have an

impact on the demand on the total utility system. In this way, the simulation can take account of the fact that the residence HVAC loads and the total system loads may be peaking at the same time, and increasing the instantaneous cost of power, if electrical back up is required at that time, and possibly also the cost of demand at the peak hour.

FIGURE 8
SIMULATION APPROACH FOR SHAC SYSTEMS

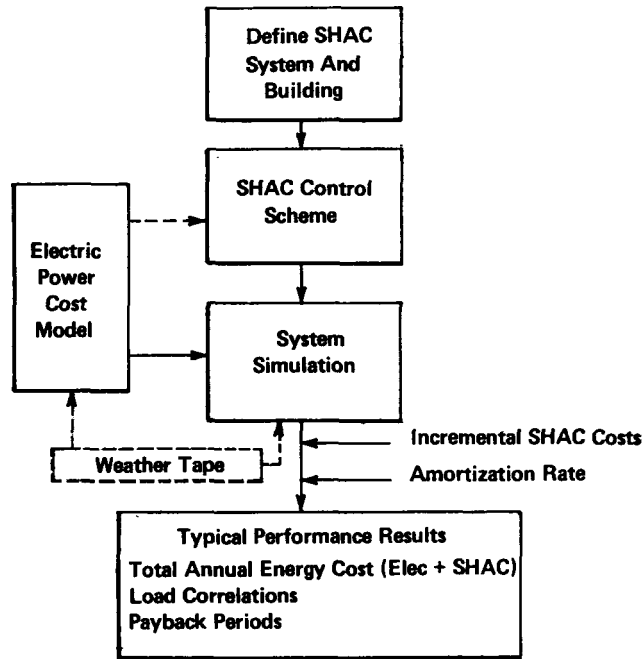

FIGURE 8
SIMULATION APPROACH FOR SHAC SYSTEMS

The computer simulation program accepts input data on the particular building, the detailed characteristics of the elements of the SHAC/Load Management System, and the cost of supply information for the particular utility service area. Weather parameters are read from tapes created by ADL from U.S. Weather Bureau Data and computations are performed over the entire year, at 15-minute intervals during the period from 9 A.M. to 4 P.M. and hourly at other times. Examples of some of the information included in the computer output data are:

- Monthly and annual cost of electrical supply, which can be added to the annual

incremental ownership costs of the SHAC system to arrive at a total annual energy cost.

- Straight Payback Periods, the ratio of incremental first cost to annual energy cost savings (compared to the conventional system).
- Average hourly load profiles for the conventional residence, the SHAC residence and the total utility system.
- Statistical correlations between the SHAC demand and the total utility system.
- Comparisons to revenues achieved with specified current or "experimental" rate structures.

FIGURE 9
HEATING LOADS IN RESIDENTIAL BUILDINGS
(ALBUQUERQUE)

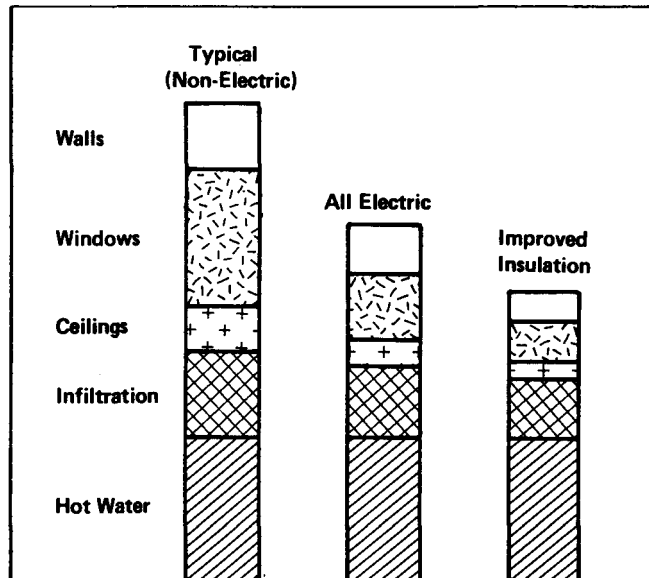

FIGURE 9

HEATING LOADS IN RESIDENTIAL BUILDINGS

Prototypical residential buildings were defined for Albuquerque and Long Island. These

- Were single family detached buildings.
- Were well insulated (typical of all-electric), and
- Used construction typical for the region.

For the Albuquerque region, the figure shows the relative magnitude of elements of the heating load for three types of residences: a typical non-electric, the prototype all-electric, and an improved insulation design. The commercial types of energy conservation measures considered in these three cases are summarized below:

	<u>Typical</u> <u>(non-electric)</u>	<u>All-electric</u>	<u>Improved</u> <u>Insulation</u>
Ceiling Insulation	3 1/2"	6"	10"
Wall Insulation	2 1/4"	3 1/2"	5 1/2"
Windows	Single pane	Double glaze	Triple glaze

The "all-electric" design in the center is representative of the building considered in our computer sensitivity studies. When specific experiments are designed for specific buildings, the energy conservation improvements will be considered which are cost effective, compatible with current housing practices, and commercially available.

The comparison shows that in the all-electric case even if additional improvements in insulation could be implemented cost effectively, there would still be a substantial heating load that could be partially satisfied by a SHAC system.

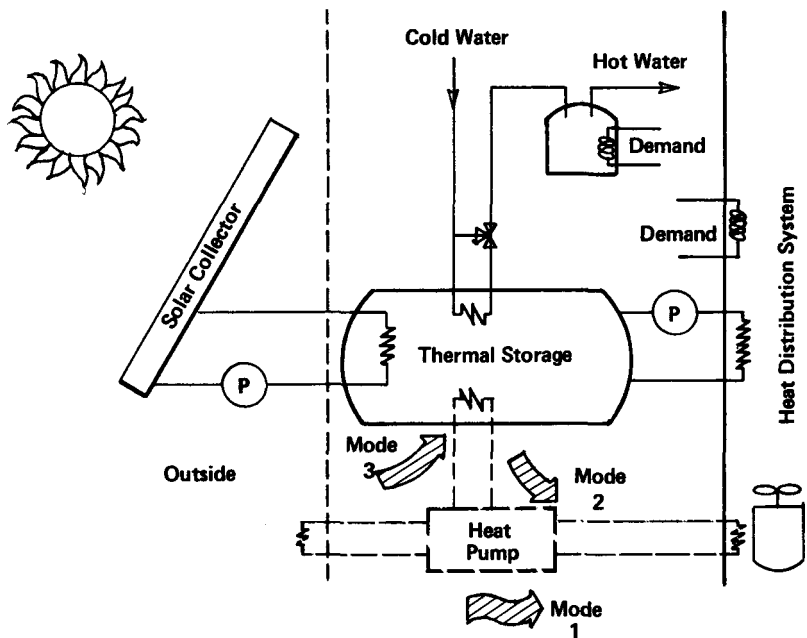

ILLUSTRATIVE SYSTEM

FIGURE 10

ILLUSTRATIVE SYSTEM

The hot water and space heating system in the figure is presented primarily to aid in the discussion of some of the issues which arise when SHAC systems are considered in conjunction with electrical load management.

For illustration, first consider the system without the heat pump; a solar collector with heat delivered directly to and from thermal storage. Here, space heating requirements and hot water preheating needs are satisfied by circulating heat from storage; backup is provided by electrical resistance demand heaters.

Introducing a heat pump to this system, as is conceptually shown, introduces new decision variables, both in equipment options and operating modes. For example, consider the original system with a 2-pane solar collector and a flat black absorber. Introducing the heat pump operating in Mode 3 (delivering heat from the outside to solar thermal storage) could be of interest during a period when the electric utility's cost of supply is low (off-peak period). However, with only the Mode 3 arrangement, there could be an important performance penalty, since the resultant increased storage temperature could substantially reduce solar collector efficiency and adversely affect overall system efficiency. This, in turn, suggests the following additional examples of system modifications: a) introduction of a special additional storage tank dedicated to the storage of heat delivered during designated off-peak operating periods; b) continued use of the solar thermal storage for off-peak operation, but changing the collector to a high-performance, perhaps more costly type, which would have a higher efficiency at increased storage temperatures; and c) the use of more than one thermal storage tank in conjunction with more than one type of solar collector.

As another option, operation of the heat pump in Mode 2 (solar-assisted heat pump) appears to have the advantages of reducing the temperature of thermal storage and increasing solar collection efficiency; permitting use of a low-cost solar collector; and permitting heat pump operation over a large part of the heating season, which would reduce usage of resistive backup, and reduce compressor cycling.

An important consideration influencing selection of Mode 2 is that when the storage temperature is high enough, it is the most efficient in delivering heat to the heat distribution system directly from storage via a circulating pump as opposed to using intermediate compressor power. Mode 2 operation could be of particular interest in very cold climates where the external temperatures are frequently too low for operation of air-to-air heat pumps. It should be noted that several variations on this theme -- introducing additional storage tanks and flow options -- are possible.

Operation of the heat pump in parallel with delivery of heat from thermal storage (Mode 1) can be more productive than the other two modes, particularly in areas with relatively mild climates.

FIGURE 11
SYSTEM CONSIDERATIONS

Function, Loads

Solar Collector	Type Mixes Area
Thermal Storage	Number Capacity Function
Controls/Scheme	Temperature Timing Power Limit

Back up HVAC System

FIGURE 11
SYSTEM CONSIDERATIONS

The preceding illustrative system introduced the fact that, when solar systems are considered in conjunction with electric load management, the number of system options and

system choices becomes very large. This chart summarizes the variables that must be considered in the design of SHAC/Load Management Systems.

FIGURE 12
TYPICAL SYSTEMS MATRIX
(SPACE HEATING SYSTEM)

		LOAD MANAGEMENT OPTIONS												
		1	2	3	4	5	6	7	8	9	10	11	12	13
SOLAR SYSTEM OPTIONS	A	•	•	•	•	•	•	•	•	•	•	•	•	•
	B	•	•	•	•	•	•	•	•	•	•	•	•	•
	C					•	•		•	•	•	•	•	•
	D				•	•	•	•	•	•	•	•	•	•
	E				•	•	•	•	•	•	•	•	•	•
	F					•	•		•	•	•	•	•	•
	G					•	•			•	•	•	•	•
	H	•	•	•	•	•	•	•	•	•	•	•	•	•
	I					•	•		•	•	•	•	•	•
	J				•	•	•	•	•	•	•	•	•	•
	K				•	•	•	•	•	•	•	•	•	•
	L					•	•		•		•	•	•	•
	M					•	•			•	•	•	•	•

• Represents System Schematic Diagrams

FIGURE 12
TYPICAL SYSTEMS MATRIX
(Space Heating System)

Comprehensive systems matrices were prepared for each separate solar function (hot water, heating and cooling) considering various options for load management and various options for solar system variations. Each cell represents an actual system that was configured and analyzed in a preliminary manner before subjecting the systems to extensive simulation. The matrix shown here is a simplified version of a large matrix that was prepared with system schematic diagrams included in every cell where appropriate.

Where the cells are blank, fundamental incompatibilities prevented the construction of a system. The load management options were based on the following uses of electric power considering applications of resistance heat and/or heat pumps:

- To satisfy instantaneous requirements
- To heat special thermal storage
- To heat solar storage
- Combinations of the above

The solar system options considered different inter-connection schemes between thermal storage subsystems and other elements.

FIGURE 13
WEIGHTED EVALUATION PROCEDURE
FOR PRELIMINARY SCREENING

- Potential Economics
- Load Management Potential
- Operational Reliability
- Availability of Equipment
- Ease of Integration

**Ratings and Weighting Factors Applied to Each
Characteristic to Reach Comparative Scores**

FIGURE 13
WEIGHTED EVALUATION PROCEDURE FOR PRELIMINARY SCREENING

The preliminary screening was a very important part of the work because it aided in developing a detailed understanding of the system options, and basic performance limitations. A weighted evaluation procedure was used in this effort to truncate the systems matrices and reduce them to a set of promising candidates that could undergo computer sensitivity studies.

The potential for economics and load manage-

ment potential was given particular emphasis in this evaluation. However, none of the basic generic classes (Load Management only, SHAC only, or SHAC with Load Management) was eliminated at this time, since that discrimination would be reserved for the time when promising systems in each category would be analyzed with the computer program using specific utility input data.

FIGURE 14
 BASELINE HOT WATER SYSTEMS
 EXAMPLE OF SYSTEM CHOICES

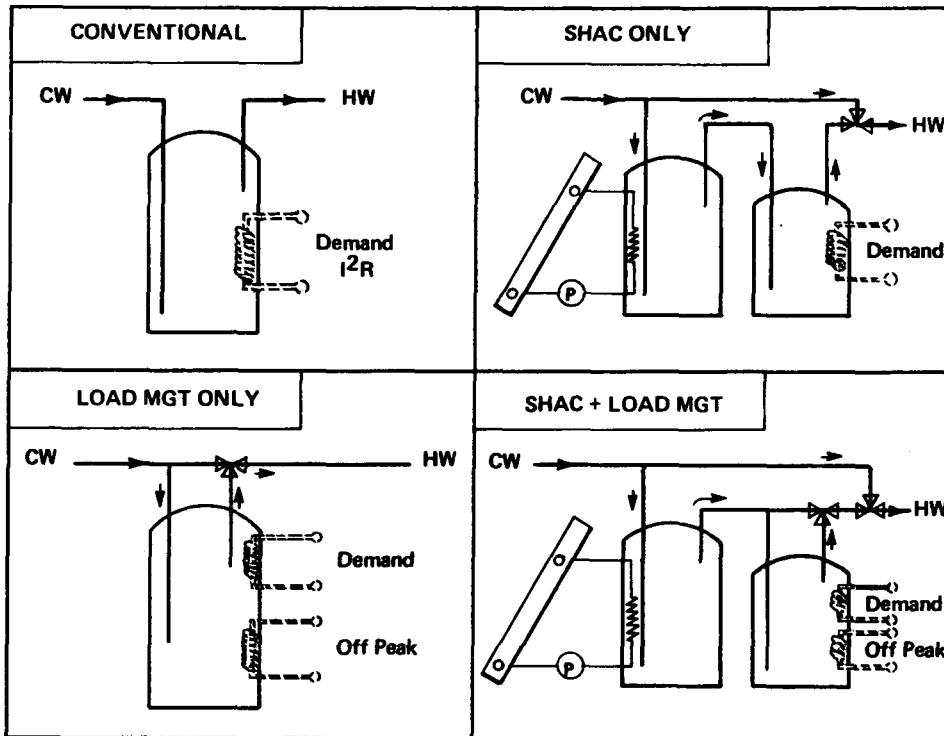

After preliminary screening and computer sensitivity studies, baseline systems matrices were prepared for each of the following functions:

- Hot water alone
- Hot water and space heating
- Combined hot water, heating and cooling

The rationale for using these functions included the following:

- a) Hot water is a single HVAC function which has promise both in load management and solar applications.
- b) Other single functions, such as heating only or cooling only, are less attractive than hot water.
- c) Combined solar hot water and heating systems have potential for increased

energy conservation with improved economic performance compared to solar heating only. A similar rationale follows for combined hot water, heating and cooling systems, especially in cases like the heat pump, where equipment can be used for both heating and cooling.

- d) The main intent of the methodology is to provide a sufficient number of system function choices for which the preferred generic class (Load Management only, etc.) can be determined. Once the preferred generic classes are identified for a particular utility, other special systems within that class can be evaluated.

This figure shows the choices of the hot water baseline systems in the four generic classes of SHAC systems. Hot water systems were chosen for the illustration because of the simplicity of the basic system configurations.

FIGURE 15
BASELINE SYSTEM MATRICES

	Hot Water	Hot Water & Space Heating		Hot Water, Space Heating, & Cooling	
		i ² R	Heat Pump	i ² R	Heat Pump
Conventional	☆	☆	☆	☆	☆
Load Mgt Only	☆	☆	☆	☆	☆
SHAC Only	☆	☆	☆	☆	☆
SHAC & Load Mgt	☆	☆	☆	☆	☆

FIGURE 15
BASELINE SYSTEM MATRICES

This figure summarizes the choices available to a particular utility when a determination of a preferred system is to be made. In our work, a different set of baseline system matrices was established for each of the two utility partners. The analyses of the baseline systems and various alternatives are being completed now and will be discussed with the utility partners in the near future.

In addition, to check the generality of the

computer simulation methodology, we will analyze the baseline systems in the next month for 14 additional utility service areas. The utilities are now preparing and furnishing the required input data in accordance with the established data formats. The baseline systems matrices that will be used in this exercise will be similar in configuration, with special consideration in sizing components and slightly modifying certain operating modes to take account of climatic differences.

FIGURE 16
PRELIMINARY CONCLUSIONS

COST OF SUPPLY APPROACH	DESIGN OF SHAC/LOAD MANAGEMENT SYSTEMS
<ul style="list-style-type: none">● Utilities Can Provide Required Information● Preferred as Compared to Use of "Current" Rates	<ul style="list-style-type: none">● Large Number of System Options● Simplicity Improves Cost Effectiveness● Cooling Systems with Heat Pumps are More Attractive Than Heat-Actuated Air Conditioners
LOAD MANAGEMENT	PREFERRED SHAC SYSTEMS
<ul style="list-style-type: none">● Attractive, Even in Service Areas with Low Fuel Cost● Feature or Add-On Capability Should be Provided by SHAC Industry to Insure Cost Effectiveness	<ul style="list-style-type: none">● Depend Upon Utility Service Area● Can Improve Overall Energy Utilization● Can Result in Cost Savings to Both Utilities and Consumers

FIGURE 16

PRELIMINARY CONCLUSIONS

A number of preliminary conclusions can be drawn from the results of the sensitivity studies which have already been performed. The conclusions will be refined and expanded after completion of all the studies for the two utility partners and the fourteen additional utility participants.

The primary remaining tasks in the Phase 0 effort deal with preparation of preliminary designs and specifications of the experimental SHAC systems planned for the service areas of the two

utility partners and development of a consultant instrumentation, test and evaluation plan.

Additionally, computer studies exercising the preferred system methodology will be performed for the fourteen additional utility participants after receipt of the input data. The additional utility participants are now in the process of preparing this data. Final reports and documentation on this project should be available by early summer of 1976.

EPRI Contract RP544-1

AN INVESTIGATION OF METHODS TO IMPROVE HEAT PUMP
PERFORMANCE AND RELIABILITY IN A NORTHERN CLIMATE

Contractor

Westinghouse Electric Corporation
Research Laboratories
1310 Beulah Road
Pittsburgh PA 15235

Program Manager

Dr. Herbert S. Kirschbaum
Phone (412) 256-7635

March 1976
EPRI Solar Review Meeting #1

This one-year project is primarily an analytical study to investigate methods of improving both the performance and reliability of heat pumps as applied to the residential sector in northern climates. The advantages and disadvantages of solar augmentation and thermal storage as system components will be studied. Analysis of the impact of these systems on utilities in terms of load profiles, rate structure, load management, and capacity displacement will be included. Three geographic locations and two building types are being utilized in the study. The prime objective is to arrive at several system configurations that would perform reliably and economically and that are capable of being produced in five years. The project is organized into six tasks. Task 1 studies the presently available standard heat pump systems. It serves as a point of reference from which to

compare both conventional HVAC systems and more advanced or unconventional HVAC heat pump systems. Task 2 has as its purpose the study of component-oriented factors which influence state-of-the-art heat pump performance. Task 3 is devoted to the investigation of benefits to be derived by including storage and storage plus solar assistance in the heat pump system. The objective of Task 4 is the evaluation of all configurations recommended during the previous tasks with regard to both performance and cost in comparison with base-case systems. Task 5 has as its objective the examination of potential problems and impacts of improved heat pump systems as they will affect electric utilities and manufacturers of heat pump systems. Task 6 will estimate the costs and resources required to develop, manufacture, distribute, install, and service each of the proposed systems.

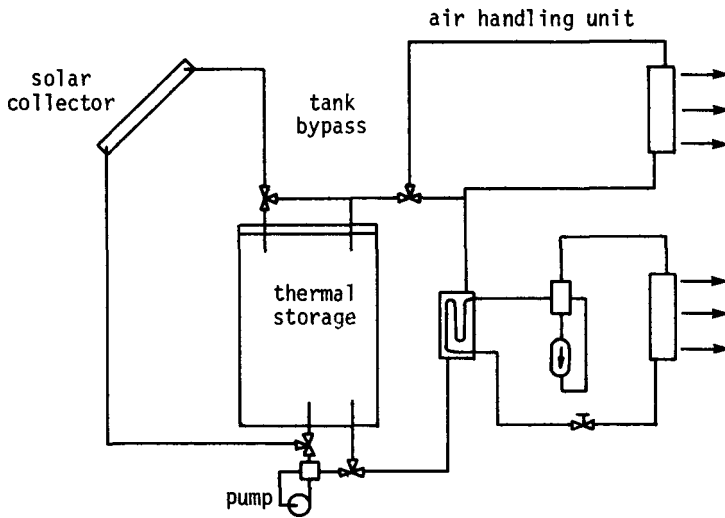

System B-4. Solar-Augmented Two-Coil Heat Pump System with Single Thermal Storage and Two-Coil Air Handling Unit.

System B-4 is the simplest of the solar-assisted heat pump systems studied in this project. Operational flexibility of this system includes the ability to supply heat to the building directly from either the solar collector or the storage reservoir. The heat pump is utilized either to boost the capacity of the system or to carry the building load alone. A maximum

of operational flexibility was designed into the system in order to take full advantage of the solar collectors and thermal energy storage reservoir in achieving both load management and improved performance. Supplemental resistance heat may be added either to the tank (off-peak application) or in the air handling unit.

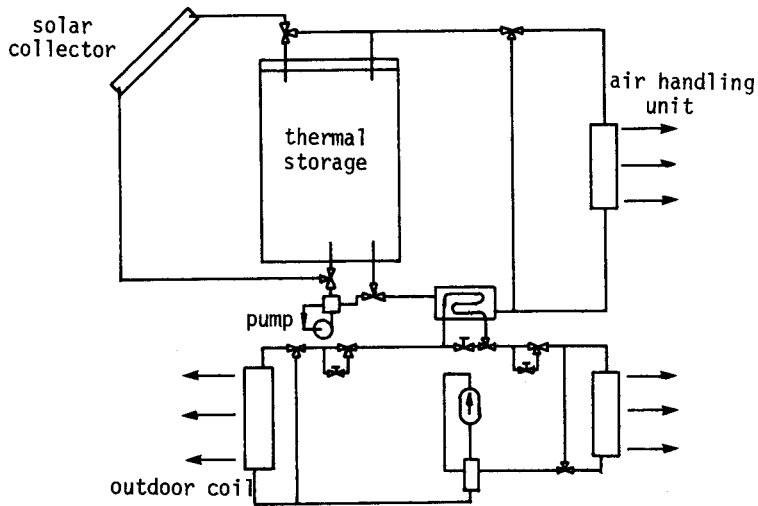

System C-4. Solar-Augmented Three-Coil Heat Pump System with Single Thermal Energy Storage and Two-Coil Air Handling Unit.

System C-4 utilizes a three-coil heat pump with solar assistance. The heat pump is configured in such a way as to allow the pumping of heat either to (or from) any one of the heat exchangers from (or to) any one of the other two heat exchangers. This additional complexity over System B-4 allows direct heat pump operation from the atmosphere in either the

storage or direct heating mode. This addition may reduce substantially the area of solar collectors required in relation to System B-4. This configuration also expands the system flexibility and offers increased opportunities to manage load and improve operating performance.

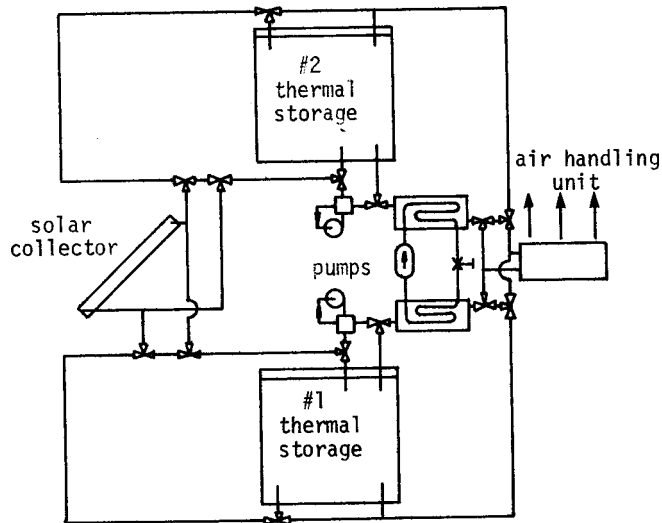

System D-2. Solar-Augmented Two-Coil Heat Pump System with Dual Thermal Energy Storage.

System D-2 utilizes two thermal energy storage units and a two-coil heat pump. The heat pump is greatly reduced in sophistication in this system; however, water circuitry complexity is substantially increased. System operation involves the storage of heat in the #2 thermal storage reservoir for direct heating application and the utilization of the #1 storage as a low temperature energy reservoir for the

heat pump. Solar collector efficiency is thus enhanced due to the availability of this low temperature sink for heat collected during periods of reduced solar heat availability due to either low ambient temperature, increased cloud cover, or suboptimal collector orientation during early morning and late afternoon.

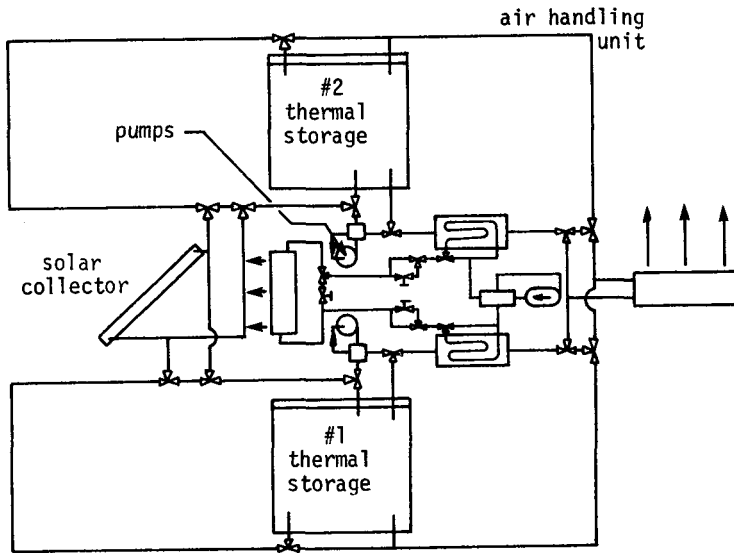

System I-3. Solar-Augmented Three-Coil Heat Pump System with Dual Thermal Energy Storage.

System I-3 utilizes a three-coil heat pump with two thermal storage units. It is the most sophisticated of the system configurations to be analyzed. The added link between the atmosphere and the system will aid the performance

of the system during extreme periods of low solar heat availability. This system is basically a combination of the advantages of Systems C-4 and D-2.

PRELIMINARY PERFORMANCE RESULTS FOR ONE-WEEK SIMULATIONS
SINGLE FAMILY - LEVEL 2 - ALBANY, N.Y.

<u>System</u>	<u>TES Tank Volume (gal)</u>	<u>Solar Collector Area (ft²)</u>	<u>Weather Type (25°F avg)</u>	<u>Overall COP</u>
Standard four-ton unit	-	-	-	1.9
B-4	1000	700	sunny	35.9
	1000	700	overcast	6.6
	500	350	sunny	14.2
	500	350	overcast	2.2
C-4	1000	700	sunny	7.3
	1000	700	overcast	4.6
	500	350	sunny	6.1
	500	350	overcast	3.5

The performance of these systems is being analyzed in two stages. At the present, one-week transient simulations are being made on each system in order to determine their relative merit with preliminary cost analysis also being property weighed. These simulations are produced by program TRNSYS obtained from the University of Wisconsin Solar Energy Lab. This analysis will result in the reduction of the four candidates to a single choice. At the present time two of the four systems have been modeled. The results shown for these systems are preliminary in nature and represent a first look at the performance of solar-assisted heat pump systems. The overall coefficient of performance includes the power consumed by the fluid transfer pumps and the indoor and outdoor fans where applicable. The average temperature for the two one-week

periods is 25°F. Values of the system parameters are obviously suboptimal and represent only a first look at system capabilities. Due to the increased system complexities of System C-4, System C-4 performance results should be greater than those of System B-4 in every case. This is not achieved due to inadequacies in the control logic initially being implemented by the simulations. Future work will thus include improvement of the system's control logics, further modeling work, and analysis of the system's performance during the cooling season. The resulting single system will then be analyzed in Task 4 as to its merits relative to other heat pump improvement techniques. A season-long simulation will be utilized in this task in order to determine the system's seasonal performance and annual cost of operation.

EPRI CONTRACT RP-550-1

SOLAR MATERIALS & COMPONENTS
TEST PROGRAM

CONTRACTOR

BLACK & VEATCH CONSULTING ENGINEERS
POWER DIVISION
1500 MEADOWLAKE PARKWAY
KANSAS CITY, MISSOURI 64114

PROGRAM MANAGER

SHELDON L. LEVY
PHONE (816) 361-7000 XT 584N

MARCH 1976
EPRI SOLAR REVIEW MEETING #1

TASKS

- FACILITY FUNCTION DEFINITION
- FACILITY REQUIREMENTS DEFINITION
- SITE EVALUATION
- CONCEPTUAL DESIGN
- COST ANALYSIS

This study was undertaken with the objective of defining a facility that would be capable of satisfying materials and components testing needs in support of the EPRI Solar Program and Subprograms.

The following specific tasks have been undertaken toward the accomplishment of this objective.

Facility Function Definition - Survey of existing test facilities, and review of EPRI Solar Sub-program goals to define the scope of needed testing services.

Facility Requirements Definition - Determination of the facility requirements based on the need for testing services.

Site Evaluation - Preliminary review of candidate locations for a testing facility.

Conceptual Design - Development of a conceptual design for a testing facility.

Cost Analysis - Preliminary estimate of costs for the implementation of a testing program.

During the course of the study, and as a consequence of review meetings with EPRI and member utility personnel, the scope was redirected to the consideration of a "testing program", regardless of whether that program utilized an actual "facility". This report is therefore concerned with not only the development of an EPRI Solar Materials and Components Test Facility but also addresses the broader question of the need for testing services, and the alternative means for providing those services.

This report is presented in nine principal sections: 1) Testing Program Rationale, 2) Functional testing needs, 3) Testing requirements, 4) Testing demand schedule, 5) Test program alternatives, 6) An EPRI facility, 7) Purchase of tests, 8) Analysis of Options and 9) Recommendations.

RATIONALE FOR SMCTF

- EPRI TEST DATA NEEDS
- COMMONALITY AMONG SUBPROGRAMS
- TEST DATA AVAILABILITY

EPRI and the utilities need a Solar Materials and Components Test Program to:

1. Provide EPRI with the capability to develop data for performance verification without the bias that could occur from the use of either private (vendor) or governmental test facilities. Such bias could be in the form of a test whose objectives are intrinsically different from one aimed at evaluating devices for an electric power system.
2. Provide critical data to be used in analyses of the interrelationship between technical performance, objectives, and economics of electricity supply, and then to apply the results to the EPRI research and development program for solar energy.
3. Assure that EPRI has coordinated data vis-a-vis the voluminous potpourri of industry, government and academic data.
4. Insure the availability of information and technology to meet certain regulatory requirements, such as establishment of allowable depreciation rates, reliability standards, etc.

SOURCES OF PURCHASED DATA

- COMMERCIAL
- GOVERNMENTAL
- ACADEMIC

EPRI can meet its data needs by contracting (purchasing) test services to its specifications (experiment design and protocol provided to the vendor) and/or by having a facility to perform in-house testing. Vendors sources include commercial, government and academic organizations and are characterized as shown on the slide.

Factors that enter into the "make or buy" decision are:

- Control of experimental protocol.
- Timeliness of test data availability.
- Flexibility to respond to EPRI-utility needs.
- A testing resource within EPRI for other than solar energy program needs.

The sources of data from different vendor groups have the following advantages and limitations:

COMMERCIAL:

Advantage

Responsive to the Customer

Limitations

Limited consulting services, limited equipment and staff resources.

GOVERNMENTAL:

Advantages

Extensive Equipment and Staff

Limitations

Bias potential, lack of protocol specified, timeliness questionable as the work is done on a noninterfering basis.

ACADEMIC:

Advantages

Extensive Equipment and Staff Highly Specialized

Limitations

Organized for research not testing needs. Usually one technical area per professor and "multiple discipline test" must be coordinated by the client at several schools.

TESTING NEEDS

- **PERFORMANCE TESTING**
- **OPTICAL PROPERTIES DETERMINATION**
- **LIFETIME TESTING**
- **ACCELÉRATED LIFETIME TESTING**
- **FAILURE MODE ANALYSIS**

The functional needs of testing in each of the three solar subprograms (SHACOB, ST, and PV) have been determined by review of the EPRI subprogram plans and through consideration of the physical character of the systems involved. The general testing functions applicable to the subprogram are as shown.

FUNCTIONAL TESTING NEEDS OF SHACOB SYSTEMS

<u>SUBPROGRAM SUBSYSTEMS</u>	<u>TESTING FUNCTION</u>				
	<u>PERFORMANCE TESTING</u>	<u>OPTICAL PROPERTIES DETERMINATION</u>	<u>LIFETIME TESTING</u>	<u>ACCELERATED LIFETIME TESTING</u>	<u>FAILURE MODE ANALYSIS</u>
REFLECTOR, LENS	X	X	X	X	X
SOLAR COLLECTOR	X	X	X	X	X
FLUID HANDLING	X				
ORIENTATION, PUMP & FAN REGULATION	X		X		
HEAT TRANSFER	X				
THERMAL STORAGE	X		X	X	X

SOLAR HEATING AND COOLING OF BUILDINGS SYSTEMS (SHACOB)

SHACOB systems are in limited current use and it is generally agreed that the most likely near-term applications of solar energy will occur in the SHACOB area. SHACOB systems involve state of the art technology. Developmental efforts are aimed at reducing the cost; improving the performance; and, to a lesser extent, improving the long-term reliability of such systems.

The EPRI plan for SHACOB includes demonstration programs for the individual load center (ILC)-residential in 1976 through 1978, ILC-commercial and light industrial in the 1977 through 1979 period, and a large scale community load center (CLC) in the 1977 through 1979 period and beyond. Another item in the plan is a study of Solar Assisted Heat Pump Systems.

A principal issue relating to SHACOB is the

determination of a preferred system and the projection of operating and maintenance costs. The high capital investment requirements of SHACOB systems make it imperative that such systems be long-lived. Another matter of consequence to the electric utilities is the impact of SHACOB systems on electricity demand patterns.

The ILC and CLC projects will provide operational information on SHACOB systems. They will not, however, provide guidance on how a new materials development would influence the selection of a system.

Testing conducted through the solar materials and components testing program would provide information pertinent to operation and maintenance costs, lifetime, failure modes, and performance.

Careful control of test procedures and measurement techniques will be required if comparable data are to be obtained.

FUNCTIONAL TESTING NEEDS OF SOLAR THERMAL POWER SYSTEMS

<u>SUBPROGRAM SUBSYSTEMS</u>	<u>TESTING FUNCTION</u>				
	<u>PERFORMANCE TESTING</u>	<u>OPTICAL PROPERTIES DETERMINATION</u>	<u>LIFETIME TESTING</u>	<u>ACCELERATED LIFETIME TESTING</u>	<u>FAILURE MODE ANALYSIS</u>
HELIOSTAT	X	X	X	X	
SOLAR RECEIVER	X	X	X	X	X
ORIENTATION, PUMP & VALVE REGULATION	X		X	X	
FLUID HANDLING	X				
HEAT TRANSFER	X				
THERMAL STORAGE	X		X	X	

SOLAR THERMAL POWER SYSTEMS

The term "solar thermal" applies to those systems which rely on the concentration of solar energy over large areas for the purpose of driving Rankine or Brayton thermodynamic cycles. Solar thermal system concepts envisage collecting solar energy either with mirrors (heliostats) which focus the energy on a central receiver or with numerous distributed collectors. With either concept, the thermal energy is concentrated and applied as the heat source to, for example, a conventional steam cycle electrical generating unit or perhaps in the case of the central receiver, to a Brayton cycle prime mover.

The central receiver power system concept is utilized in this report as being generally illustrative of solar thermal power system concepts.

The solar thermal subprogram is concerned with

achievement of realistic and affordable capital and operating costs, demonstration of pilot plant systems, verification of materials and component serviceability, development of high temperature energy storage, and improvement of thermal conversion device performance.

Although most of the testing requirements for the solar thermal program will be allied with developmental activities, there are certain additional needs for materials and components testing. It is expected that a single heliostat and its control system might be tested. Corrosion tests of molten salts or eutectic energy storage media might also be undertaken. Determination of reflector optical properties and their degradation mechanisms would be important for heliostats. Metals or ceramics used as absorber tubes in central receivers would require testing to determine their ability to withstand thermal shock and fatigue.

FUNCTIONAL TESTING NEEDS OF PHOTOVOLTAIC SYSTEMS

<u>SUBPROGRAM SUBSYSTEMS</u>	<u>TESTING FUNCTION</u>				
	<u>PERFORMANCE DETERMINATION</u>	<u>OPTICAL PROPERTIES DETERMINATION</u>	<u>LIFETIME TESTING</u>	<u>ACCELERATED LIFETIME TESTING</u>	<u>FAILURE MODE ANALYSIS</u>
REFLECTORS, LENS	X	X	X	X	
SOLAR ARRAY	X		X	X	X
ORIENTATION, POWER MODULATION	X		X	X	

PHOTOVOLTAIC SYSTEMS

The characteristic of direct conversion of sunlight to electricity is unique to the solar photovoltaic cell in which the incident photons produce an electric power source. The intrinsic nature of photovoltaic cells is that their output is in the 0.5 to 1.0 volt range. The state-of-the-art is such that these cells can only be made in small sizes. Arrays consisting of many interconnected cells are used for the production of practical amounts of power.

Most terrestrial applications of photovoltaic systems have been for low-voltage, low-power systems. Although the typical terrestrial application consists of a fixed orientation array, photovoltaic system concepts include arrays, concentrating mirrors or lenses, and utilization of heat rejected in the process of cell cooling (the "total energy" approach).

The main issues of the EPRI photovoltaic subprogram are directed to the development of those technolo-

gies which are of direct benefit to electric utilities. Photovoltaic technology is rapidly evolving, requiring that the EPRI subprogram remain sufficiently flexible to continually appraise the state-of-the-art. EPRI-sponsored photovoltaic work includes studies related to single crystal silicon and research on cadmium sulfide, cuprous sulfide (CdS/Cu₂S) solar cells. Advanced concepts such as ternary cell systems (e.g., Al_xGa_{1-x}As, CuInS₂, CuInSe₂) which could be operated at high levels of solar concentration are possibilities which may warrant increased future attention by EPRI. In addition to the essential emphasis on solar cell technology, the EPRI photovoltaic subprogram is directed to the development of power preconditioning apparatus that would be serviceable in a utility environment. The collection of power and its transfer from arrays to storage or preconditioning apparatus is an area that requires further design and development work, although it is not anticipated that special testing emphasis will be required.

TESTS

1. THERMAL DEGRADATION AND CREEP
2. MAXIMUM ABSORBER TEMPERATURE AND PRESSURE
3. THERMAL CYCLING / FATIGUE
4. TRACKING SYSTEM PERFORMANCE
5. THERMAL RATCHETING
6. WEATHERABILITY
7. UV RESISTANCE

SOLAR MATERIALS AND COMPONENTS PROGRAM TEST DESCRIPTIONS

1. Thermal Degradation/Creep: Some materials and components, when exposed to high temperatures and/or stress for long periods of time, undergo changes in structure (degradation) or shape (creep).
systems for which a high degree of performance is required (i.e., high concentration systems).
2. Maximum Absorber Temperature and Pressure: The tests of this category are for determination of the sustained operating temperature and pressure limits of absorbers, including the temperature limitations of photovoltaic arrays.
3. Thermal Cycling/Fatigue: This test category is for determination of the ability of a material to withstand cycling between extremes of temperature over long periods of time. Cycling tests may be accelerated for purposes of predicting lifetimes.
4. Tracking System Performance: This test category is for determination of the accuracy, precision, and repeatability of
5. Thermal Ratcheting: This test category is aimed at testing components and materials to determine their ability to resist permanent deformation and warping due to repeated non-uniform heating and cooling.
6. Weatherability: Tests within the weatherability test category are used to determine a material's ability to withstand environmental conditions. Both real time and accelerated time testing will be performed. Both natural and simulated environments will be utilized.
7. UV Resistance: The UV resistance test category is to determine the effects of sustained ultraviolet (UV) radiation has on materials. The materials will be exposed to both artificial and natural sources of UV radiation.

TESTS (CON'T)

8. OPTICAL PROPERTIES
9. MIRROR CHARACTERISTICS
10. THERMAL SHOCK
11. CORROSION
12. LENS PERFORMANCE
13. FLUID PROPERTIES

8. Absorptance /Emittance/Transmittance/Reflectance: This test category is for determination of the optical properties of materials at their working temperatures.

9. Mirror Reflectivity/Precision: The reflectance and surface profile, or the deviation from a prescribed profile, of heliostats and concentrators are determined under this test category. Tests may be repeated over a period of time to check for changes in properties as a result of environmental exposure, creep, aging, and the like.

10. Thermal Shock: Thermal shock tests permit determination of how well a material can withstand an extreme rapid change in the

temperature of its environment or a sudden exposure to intense thermal radiation.

11. Galvanic/Chemical Corrosion: These tests are to provide data on the corrosion resistance of materials and to determine the compatibility between materials and fluids.

12. Lens Performance: These tests are to measure the overall efficiency and performance of a lens concentrating system.

13. Fluid Stability/Viscosity/Conductivity: The viscosity and thermal conductivity of the fluids is to be measured at working temperatures. Tests will be made to determine the chemical stability of fluids.

TESTS (CON'T)

14. INSULATION STABILITY
15. ABSORBER CONDUCTIVITY
16. COLLECTOR PERFORMANCE
17. INSULATION CONDUCTIVITY
18. ABSORBER STABILITY
19. PHOTOVOLTAIC ARRAY PERFORMANCE

14. Insulation Stability: These tests are complementary to the insulation thermal conductivity test (see Insulation Thermal Conductivity). The insulation stability test provides data on the ability of a specific insulation material to tolerate its environment and gives an indication of its expected life.

15. Absorber Conductivity: Absorber conductivity tests are to measure the thermal conductivity of the absorber material. These conductivity tests are to be performed at the absorbers operating temperatures.

16. Collector Performance: The overall efficiency and performance of distributed-type system collectors (e.g., flat plate)

will be determined by these tests.

17. Insulation Thermal Conductivity: These tests are for determination of thermal conductivity of insulating materials. Insulation is to be tested at service temperatures.

18. Absorber Surface Stability: These tests are designed to measure the stability of the absorber coatings spectral response and the adherence of coatings to substrates when subjected to design conditions.

19. Photovoltaic Array Performance: The performance, operating limits, and efficiency of photovoltaic arrays are determined by these tests.

DEMAND SCHEDULE

- SUBPROGRAM TEST NEEDS
- TEST MAN HOUR REQUIREMENTS

DETERMINATION OF TESTING DEMAND

In order to completely describe the testing requirements it is not sufficient to know what type of a particular type will be needed. If, for example, a particular test would be performed only rarely, it would be prudent to utilize existing capabilities to perform the test. That is, it would likely not be prudent to invest in special facilities to perform an occasional test.

Such considerations with respect to the "loading" of test facilities are especially important to solar materials and components testing inasmuch as it is not envisaged that a large number of

materials and components would be tested.

In order to determine the demand for testing that could be expected during the 1976 through 1980 time frame, the counsel of persons having special knowledge with respect to EPRI solar subprograms and the pertinent solar technology was sought. Expert judgments were condensed to an estimated frequency of testing or an estimated loading (tests per year) for a particular category of test. Testing frequencies for each of the three classes of tests for each year 1976 through 1980 were developed.

ESTIMATES OF TESTING LABOR
1976 - 1980

<u>YEAR</u>	<u>TESTING LABOR</u>	
	<u>MAN-DAYS</u>	<u>MAN YEARS</u>
1976	459	1.95
1977	1200	5.10
1978	1312	5.58
1979	1511	6.43
1980	1356	5.77

TESTING LABOR

The estimated labor requirements (man-day) for the performance of tests within each test category, excluding staff time required for supervision, experiment design, and analysis.

"Testing," as construed in the development of these tables, does not consist of a single "test". Instead, an instance of "testing" would consist of a series, or battery, of tests which were directed toward a particular determination. For example, if it were desired to determine the long-term creep strength of a material or component,

a sufficient number of test specimens would need to be tested to give statistically significant results.

The direct labor component involved in implementing the testing activities of the solar materials and components testing program is seen to be on the order of six persons in the years after 1976. This manpower component is for testing alone and does not include personnel requirements for test program administration and essential technical services such as test standards development, statistical analysis, and data processing.

ALTERNATIVES

1. IN-HOUSE TESTING
2. IN-HOUSE AND PURCHASE OF TESTING
3. PURCHASE OF TESTING SERVICES

TESTING PROGRAM IMPLEMENTATION ALTERNATIVES

At the outset of the current project, the project orientation was toward describing a solar materials and components test "facility". It quickly became evident, however, that EPRI's need was for a testing "program" which could effectively utilize testing resources. That is, it is not essential to have a facility, as such, in order to conduct tests which need to be performed. Indeed, some tests that are needed are of such specialized nature that it would be impractical to support the capability if that would entail duplicating existing facilities.

The alternatives available to EPRI for testing of solar materials and components range from the construction and operation of a testing facility with relatively comprehensive capabilities to the contract purchase of all needed tests and services. Out of all the alternatives three basic approaches, or "plans" were examined

Plan 1--EPRI would construct and operate a solar materials and components test facility at which the majority of materials components testing required by the EPRI solar program would be performed.

Plan 2--EPRI would construct and operate a solar materials and components test facility (as in Plan 1 but with a smaller capability). Less frequent testing requirements would be satisfied by contract purchase of testing services.

Plan 3--EPRI would exclusively rely on contract purchase of testing services to satisfy requirements for solar program testing.

Within these three plans there are still many variations on a theme. For example, EPRI may contract for facility management or test purchase management or may provide their own staff for these efforts.

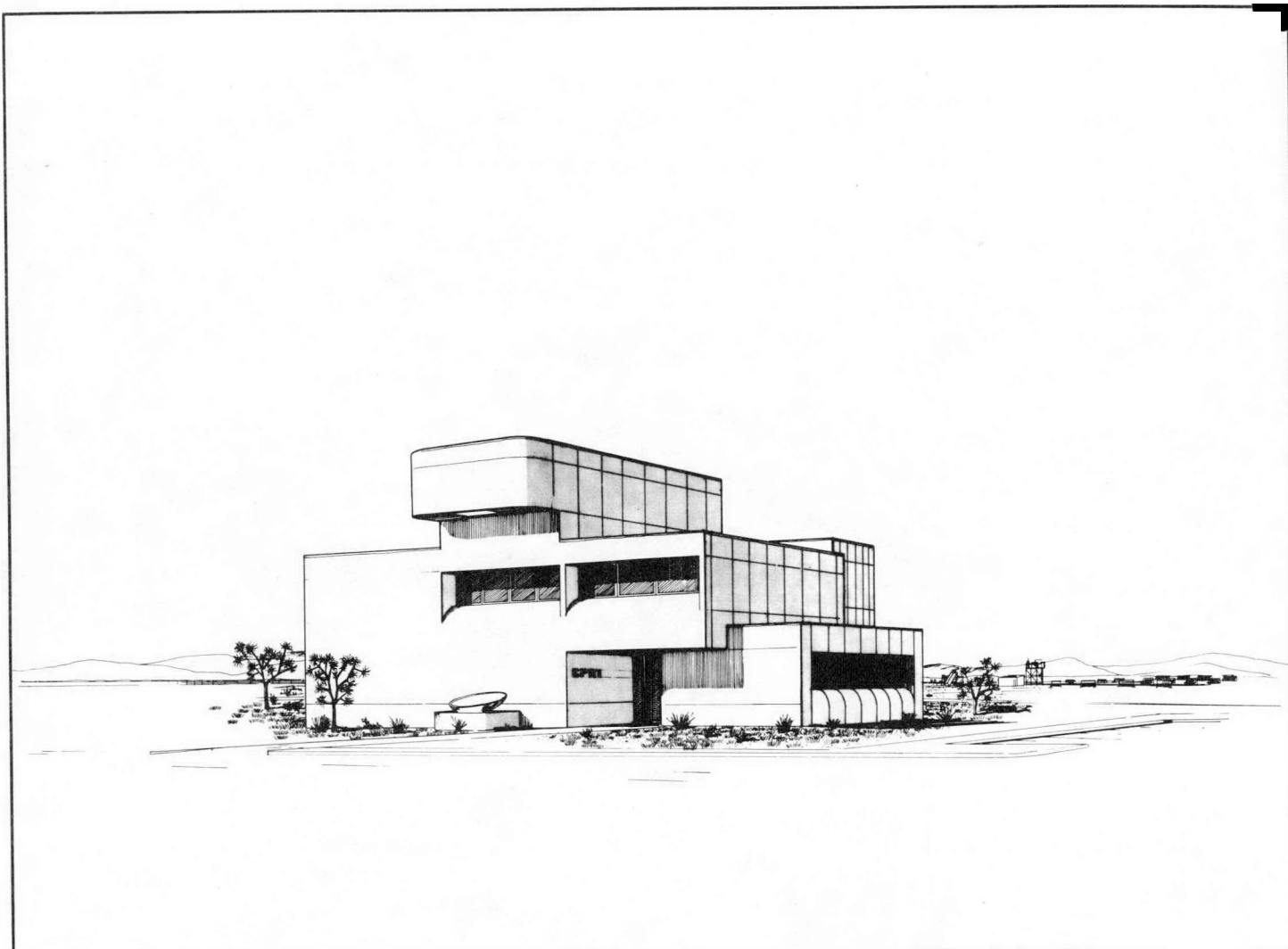

				DEPT HEAD	I HEREBY CERTIFY THAT THIS PLAN WAS PREPARED BY ME OR UNDER MY DIRECT SUPERVISION AND THAT I AM A DULY REGISTERED PROFESSIONAL ENGINEER UNDER THE LAWS OF THE STATE OF	BLACK & VEATCH CONSULTING ENGINEERS PROJECT 6984	EPRI SOLAR MATERIALS AND COMPONENTS TEST FACILITY CONCEPTUAL DESIGN VIEW FROM SOUTHEAST	P & V DWG NO. 1
				DESIGNER				
				CHECKED				
				DRAWN D.D.S.				
DATE	REVISIONS AND RECORD OF ISSUE	NO.	BY	CHK	APP	SIGNED	DATE	REG NO.

EPRI FACILITY

An EPRI-sponsored testing facility for the solar materials and components testing program would require organization in a manner that is responsive to the needs of the EPRI solar sub-programs. So far as the performance of testing functions is concerned, it is the individual test facilities, laboratory facilities, and technical services which are of interest.

The test facility would be on a 10 acre site. The 10,000 square foot building would contain

- Administrative and Conference 1100 sq. ft.
- Laboratories 3200 sq. ft.
- Technical Services 1100 sq. ft.
- Staff Facilities 1100 sq. ft.
- Mechanical, Corridors, etc. 3500 sq. ft.

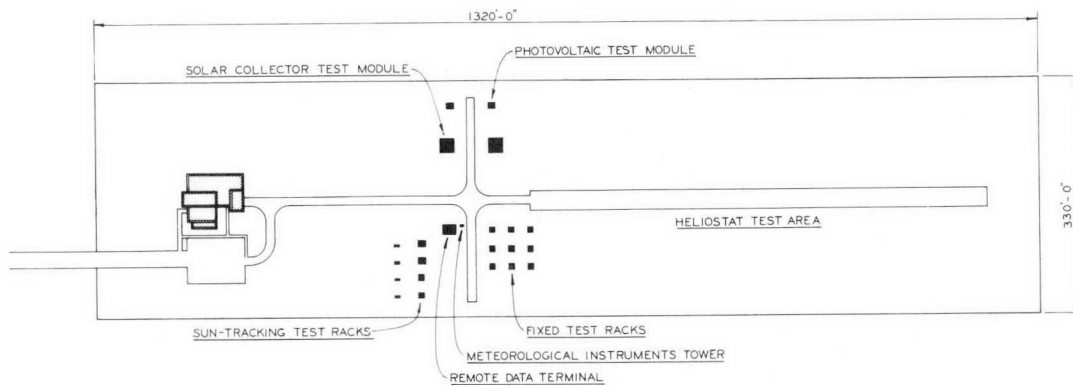

TEST FACILITIES

Outdoor Test Area. Facilities for exposure testing, tracking system performance testing, and for collector and photovoltaic array performance testing. A number of different fixed, one-axis and two-axis test racks, concentrating test racks, and associated equipment would be used to perform exposure tests.

Indoor Test Area. The principal testing function to be performed in the indoor test area would be the determination of the performance of components and materials under controlled solar and environmental conditions.

LABORATORY FACILITIES

Materials Laboratory. This laboratory would be oriented to the testing of materials and the examination of the structure of materials to measure performance, determine failure mechanisms, and provide guidance with respect to appropriate application of materials. This laboratory would also perform thermometric and heat flux measurements as well as measurement of the thermal

properties of materials and heat transport media.

Optics Laboratory. This laboratory would measure critical optical properties of materials such as absorption, reflection, transmission, and emission as a function of wavelength and temperature as appropriate. The optical characteristics of mirrors and lenses would also be measured in this laboratory. Measurement of tracking system performance would be the responsibility of this laboratory.

TECHNICAL SERVICES

Data Collection. Data collection would be accomplished through the use of a centralized automated system.

Equipment/Calibration. The equipment/calibration element would be responsible for the maintenance and calibration of equipment, both electrical and mechanical.

Specialist Services. This organizational element would provide assistance in the areas of experimental design, the statistical analysis of data, and the establishment of standards and procedures.

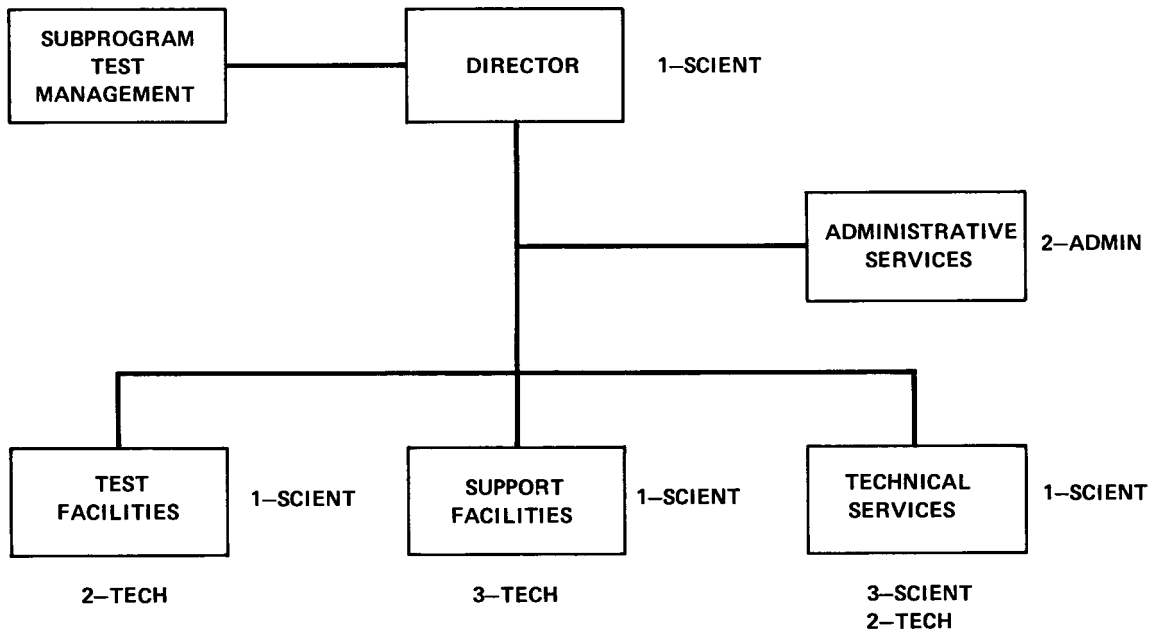

**STAFFING OF AN EPRI SMCTF
PLAN 1**

STAFF

The EPRI-sponsored testing facility would require staffing with personnel who are qualified to undertake the anticipated testing program. In general, this indicates a requirement for a high level of competence among the technical staff and a reasonable level of staff support in order to be able to carry out a meaningful program of materials and components testing.

Three primary staff categories are identified and discussed as follows.

1. Scientific/Technical Staff.
2. Technical Staff.
3. Administrative Services Staff.

In addition to the services provided by the staff, contract services would also be used in some cases.

Staff categories and tentative staffing requirements for the testing facility for Plan 1 and Plan 2 are shown below. Because under a Plan 2 development, the facility is to contract out some of the tests to other facilities and, thus, performing fewer tests at the facility than under Plan 1 development, Plan 2 will require less staffing. Plan 2 has two fewer technicians than Plan 1.

Plan 1

<u>Staff Category</u>	<u>Number</u>
Scientific/Technical	7
Technical	7
Administrative	<u>2</u>
Total	16

Plan 2

<u>Staff Category</u>	<u>Number</u>
Scientific/Technical	7
Technical	5
Administrative	<u>2</u>
Total	14

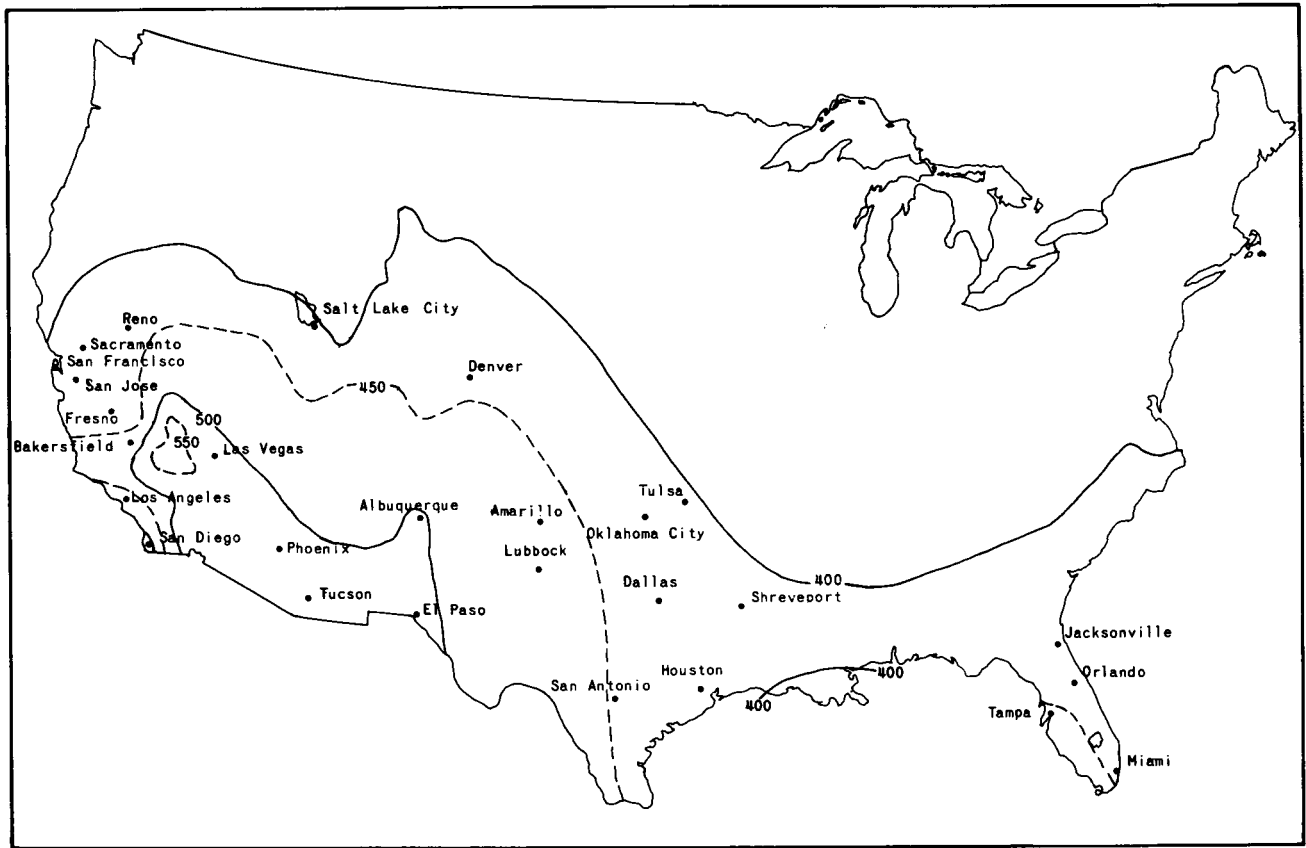

CANDIDATE CITIES AND ANNUAL INSOLATION (LANGLEYS)

SITE ANALYSIS

Criteria for choosing a candidate site were:

- High insolation
- High hours of sunshine
- Air transportation
- Educational resources
- Cooling and heating degree days
- Manufacturing employment

Basic data on the above elements were codified into rank values. The metropolitan areas which had the highest ranking were selected as those that EPRI should consider if a facility is to be constructed.

The first step was to confine the task by excluding all areas which do not have average daily insolation of 400 Langleys. The second exclusion

was all metropolitan areas that did not have good air transportation.

The remaining 27 candidates were then evaluated by a combined value from individual rank values in each category. The various ranking methodologies always resulted in seven metropolitan areas in the first seven places. Their order and rank in the final ranking method were as follows:

<u>Rank</u>	<u>Area</u>	<u>Rank Index</u>
1	Phoenix	113
2	Tucson	108
3	Las Vegas	107
4	El Paso	106
5	Los Angeles	96
6	Albuquerque	94
7	Dallas	83

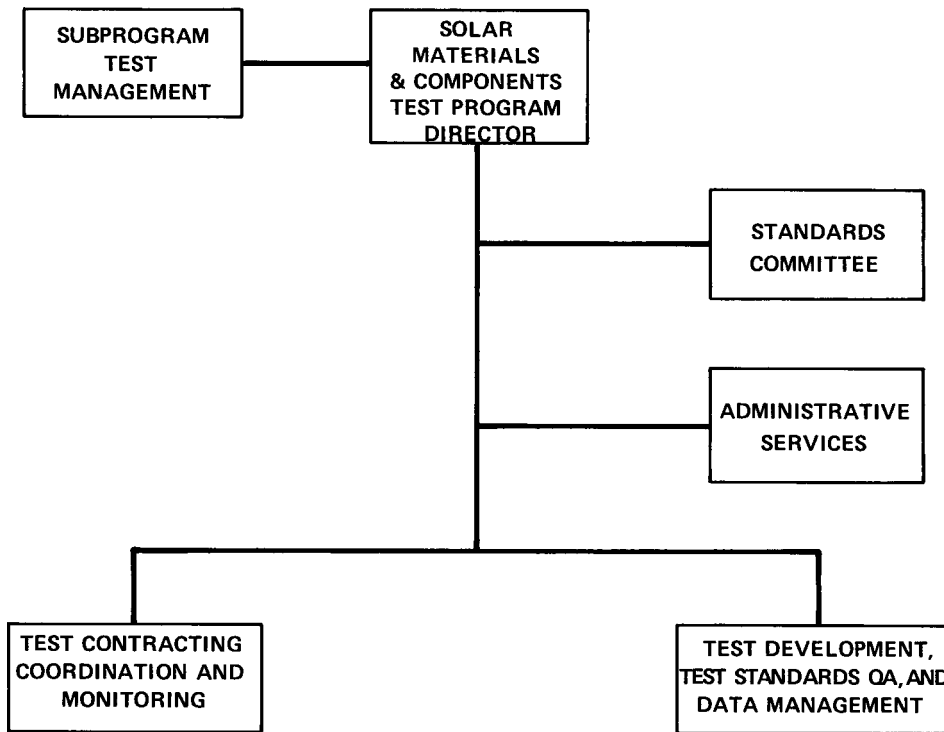

ORGANIZATION FOR PLAN 3
PURCHASE OF TESTING

PURCHASE OF TESTING

Under a Plan 3 development, wherein EPRI would exclusively rely on contract purchase of tests, the solar materials and components testing program will require an organization that will interface efficiently between the contracted testing facilities and EPRI's solar energy testing needs, especially the subprogram testing requirements. A schematic of such a functional organization which would be appropriate to fulfilling the testing needs is shown on the facing page.

Director. This position would require administrative ability as well as a strong background in the physical sciences. The director would be responsible for coordinating the operations within the

program in a manner that would be responsive to EPRI's requirements.

Test Contracting, Coordination and Monitoring

Staff. The staff of this group would be responsible for interfacing between the test facility and the contracting test facility. They are to supply the information the contractor needs to properly perform the required tests. The staff of this group should have a strong experimentally oriented background in the physical sciences. At least one member should have a background with an emphasis on materials and at least one with a strong emphasis on optics.

**STAFFING SUMMARY
PURCHASE OF TESTING**

	1976	1977	1978	1979	1980
SCIENTIFIC/TECHNICAL	1	2	3	5	5
ADMINISTRATIVE SERVICES	<u>1</u>	<u>1</u>	<u>2</u>	<u>2</u>	<u>2</u>
TOTAL	2	3	5	7	7

Test Development, Test Standards QA, and Data Management Staff. The staff of this group is to work closely with the staff of the contracting and coordination group. It is the responsibility of the staff of this group to assist in the design of tests, supplying what information is necessary. The staff must maintain a library of standards and, if none exist covering a situation, assist in the development of such standards. The staff will also statistically analyze the data obtained from testing to extract meaningful information.

Consequently, one staff member should have a strong background in statistics and be familiar with the operation of data processing equipment. At least one staff member should have an experimentally oriented background with a strong familiarity with standards and specifications.

Administrative Services Staff. Administrative services support would be provided by individuals having secretarial, clerical, and general office skills.

OPTIONS ANALYZED

- **PLAN 1: AN EPRI FACILITY**
- **PLAN 2: A SOMEWHAT REDUCED EPRI FACILITY PLUS PURCHASED TESTING**
- **PLAN 3: PURCHASED TESTING**

OPTIONS ANALYZED

Whereas an infinite variety of options can be established and analyzed three alternative plans were used to establish the range of implications for alternates available to EPRI.

Plan 1--EPRI would construct and operate a solar materials and components test facility at which the majority of materials and components testing required by the EPRI solar program would be performed.

Plan 2--EPRI would construct and operate a solar materials and components test facility (as in Plan 1). Less frequent or long-term testing requirements would be satisfied by contract purchase of testing services.

Plan 3--EPRI would exclusively rely on contract purchase of testing services to satisfy requirements for solar program testing.

In the three plans EPRI still has the option of the mix of EPRI staff and contract staff to functionally operate the plan. Thus EPRI, may have as its staff the director and other staff and/or the facility would be supplied under contract to EPRI. For the facility of Plans 1 and 2, it may be obtained by purchase, by lease or by other methods. The more significant cases were analyzed.

**COMPARISON OF ESTIMATED COSTS FOR
ALTERNATIVE IMPLEMENTATION PLANS**

<u>Option</u>	<u>Expense Category</u>	<u>Estimated Cost (\$1000)</u>					<u>5-Year Total</u>
		<u>1976</u>	<u>1977</u>	<u>1978</u>	<u>1979</u>	<u>1980</u>	
Plan 1	Capital	278	1535	464	—	—	2277
	Operating	208	1041	583	623	666	3121
	Total	<u>486</u>	<u>2576</u>	<u>1047</u>	<u>623</u>	<u>666</u>	<u>5398</u>
Plan 2	Capital	278	1384	373	—	—	2035
	Operating	208	999	634	680	772	3293
	Total	<u>486</u>	<u>2383</u>	<u>1007</u>	<u>680</u>	<u>772</u>	<u>5328</u>
Plan 3	Capital	—	—	—	—	—	—
	Operating	208	799	951	1027	1327	4312
	Total	<u>208</u>	<u>799</u>	<u>951</u>	<u>1027</u>	<u>1327</u>	<u>4312</u>

COMPARATIVE COSTS

Annual costs for Plan 1, Plan 2 and Plan 3 when broken down by capital cost and operating expense show that the reduced operating expenses for Plans 1 and 2 are offset by the capital costs associated with those plans. The numbers shown include appropriate inflation of 1975 dollars.

**COMPARISON OF ESTIMATED CASH FLOW FOR ALTERNATIVE
IMPLEMENTATION PLANS – WITH AND WITHOUT LEASING**

<u>Option</u>		<u>Estimated Cost (\$1000)</u>					<u>5-Year Total</u>
		<u>1976</u>	<u>1977</u>	<u>1978</u>	<u>1979</u>	<u>1980</u>	
Plan 1	Without Leasing	486	2576	1047	623	666	5398
	With Leasing	248	1388	923	962	1005	4526
Plan 2	Without Leasing	486	2383	1014	696	772	5351
	With Leasing	248	1308	936	980	1072	4544
Plan 3	—	208	799	987	1107	1327	4428

COMPARATIVE CASH FLOW

The comparative cash flow for Plan 1, Plan 2 and Plan 3, if the capital cost items (land, building and apparatus) for Plans 1 and 2 are acquired via long term leases or by cash outlay are shown in the chart. The lease periods for the building and land is 15 years. The lease period for the equipment ranges from 5 years (Data processing equipment) to 8 years.

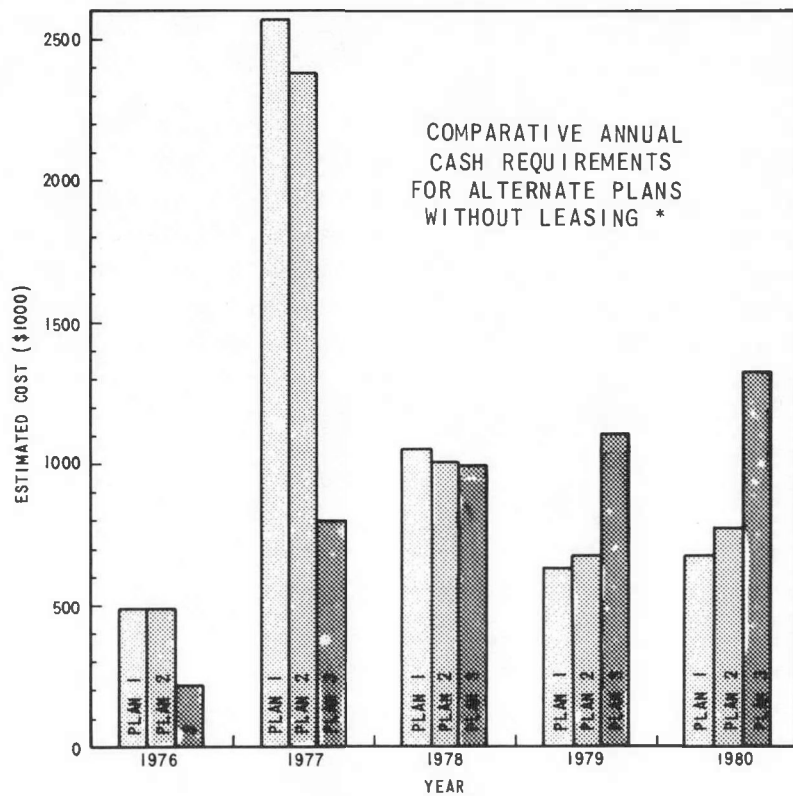
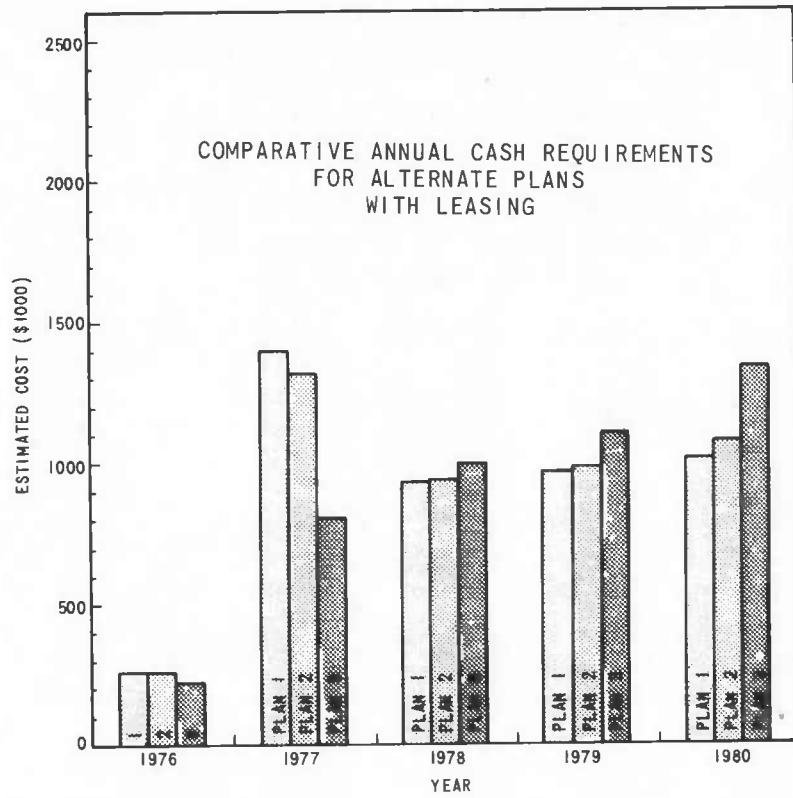

CONCLUSIONS

- COST FACTORS ARE NOT AMONG THE CRITICAL ELEMENTS IN DECISION
- CRITICAL DECISION ELEMENTS INCLUDE
 - LIFETIME OF A TEST FACILITY
 - ALTERNATE USE OF A FACILITY
 - FLEXIBILITY OF ACTION

CONCLUSIONS

This study has indicated the order of magnitude of costs that can be expected to be required for the support of Solar Program materials and components testing activities. These costs have been found to be independent of whether the testing is performed at an EPRI facility or through contract purchase arrangements. For the 5-year 1976-1980 period, cash requirements have been projected to be \$208,000 to \$248,000 for 1976, and average costs of approximately \$1,000,000 per year are projected for the years 1977 through 1980.

Inasmuch as the estimated costs for each of the testing program implementation options are approximately the same, no clear cost basis is provided for determining the most advantageous approach to solar materials and components testing. The decision as to whether EPRI should underwrite a facility will therefore need to be made on the basis of factors other than comparative cost. For example, if it can be confidently

predicted that EPRI will maintain a viable solar program beyond 1980, the implementation of an EPRI facility would be favored because of the lower long term costs. Moreover, if EPRI would become involved with the other-than-solar materials and components testing needs of member utilities it is likely that an EPRI facility would be of value in serving these broader needs. Adaptability of the testing program to non-solar testing activities would therefore favor the implementation of an EPRI facility.

The implementation of any solar materials and components testing program will require that key personnel are engaged for program development and management. These personnel could consist either of additions to EPRI staff, contract services, or a combination thereof. In addition, if a facility is to be built, the processes of final site selection and facility detailed design will need to be undertaken.

RECOMMENDATIONS

- ENGAGE KEY PERSONNEL
- SCOPE THERMAL DEGRADATION/CREEP TESTS
- ESTABLISH POSITION ON EPRI FACILITY

RECOMMENDATIONS

The program revealed that individually and collectively no materials and components test program nor facility exists or is planned which will meet the needs of EPRI's solar energy subprograms without EPRI's overt action. These testing needs are essential if the utilities are to be able to act in an enlightened manner for the implementation of solar energy systems. EPRI can meet these needs by implementing the first steps of a solar materials and components testing program. It is therefore recommended that the following actions be taken:

1. Key personnel be engaged for the administration and development of the materials and components testing program by (1) additions to EPRI staff, (2) contract for services to a competent consulting organization, or (3) a combination of the two.

Specific tasks to be undertaken are as follows:

- coordinate testing needs with subprogram management
 - develop testing standards, to include measures of statistical data significance
 - develop test procedures
 - contract for initial tests to be undertaken, and administer these contracts
2. Reexamine the priorities of thermal degradation/creep testing and assess the risks of scoping tests in this area. Specifically, the question should be addressed as to whether EPRI and its member utilities can reasonably be expected to recover the costs of testing in this area - estimated to be no less than \$1,500,000 during 1976 through 1980.

It may be that preliminary thermal degradation and creep test data will indicate the testing needs are less than the presently indicated level.

3. Establish for EPRI a preferred position with respect to the question of "facility" versus "no facility". This study has forecast comparable 1976-1980 costs for either testing program alternative. Differences arise during consideration of:
 - Test program lifetime--if the test program is not to extend beyond 1980, a facility would not be warranted.
 - Benefits of EPRI control--a facility would provide the highest degree of EPRI control over test methods, procedures, and quality of data.
 - Future uses of a facility--if the solar program is seen as extending beyond 1980 at present or expanded levels of effort, a facility would be warranted. Similarly, if EPRI and its member utilities foresee expanded EPRI roles in areas of non-solar materials and components testing, a facility would be advantageous.
 - The flexibility that EPRI retains in materials and components testing.

The cost of implementing a facility during the 1976-1980 period is estimated to be approximately \$800,000 more than the minimum cost of testing program implementation. This cost would be a premium for preserving future options and would be lost if the solar materials and components testing program or alternative testing programs were not extended beyond 1980.

EPRI CONTRACT RP 552-1

SOLAR DATA VERIFICATION PROJECT

CONTRACTOR

SCIENCE APPLICATIONS, INC.
1651 OLD MEADOW ROAD
McLEAN, VIRGINIA 22101

PRINCIPAL INVESTIGATOR

ALEXANDER J. HOUGHTON
(703) 790-5900 x 273

MARCH 1976
EPRI SOLAR REVIEW MEETING #1

OVERVIEW

SCOPE & OBJECTIVE
INSOLATION & INSTRUMENTS
MAJOR CONCLUSIONS
DATA REQUIREMENTS
NWS DATA BASE
DEFICIENCIES
WORTH OF ACCURACY
MONITORING STATIONS
ALTERNATIVES
DATA MANAGEMENT
COST SUMMARY

EPRI SOLAR DATA VERIFICATION PROJECT

OBJECTIVE: TO DEFINE A PROGRAM FOR THE ACQUISITION,
AND ANALYSIS OF ENVIRONMENTAL DATA
RESPONSIVE TO THE NEEDS OF ELECTRIC UTILITIES

SCOPE: REQUIREMENTS DEFINITION & CLASSIFICATION
PROGRAM DEFINITION
SYSTEM DESIGN AND SPECIFICATIONS RECOMMENDATIONS
FOR IMPLEMENTATION

INSOLATION

GLOBAL
DIRECT
DIFFUSE
CIRCUMSOLAR

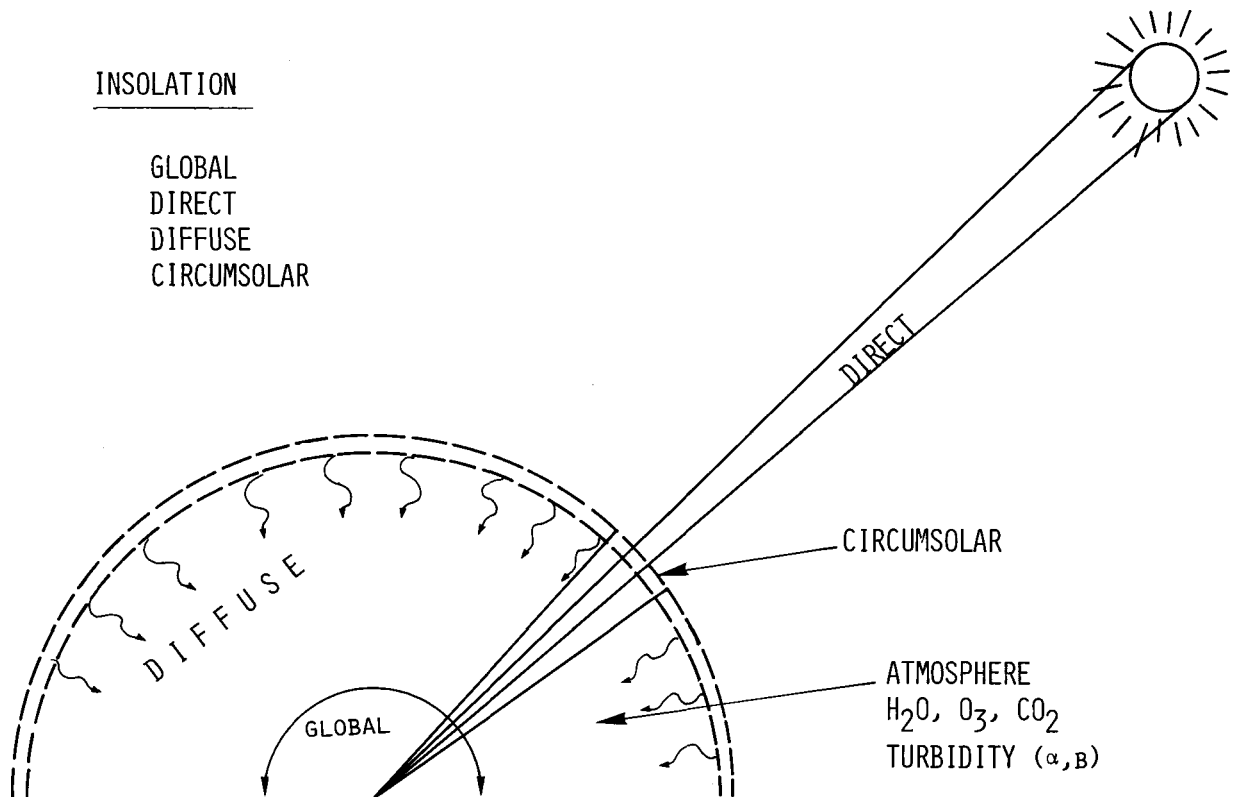

There are two principal components to the solar energy received on the surface of the earth; direct (beam) and diffuse. The direct insolation is that which traverses a straight line from the sun to the observer. The atmosphere scatters and absorbs some of the solar energy, and the portion which is scattered toward the earth is called diffuse insolation. On a clear day with the sun high above the horizon, about 80% of the insolation is direct and 20% diffuse. When the sun is low in the sky, there is more absorption and scattering and the ratio of the diffuse to total insolation is greater than when the sun is high.

The diffuse radiation from an area immediately surrounding the solar disc is considerably brighter than that from the rest of the sky and is called circumsolar radiation. Under clear sky conditions, the circumsolar radiation received by an instrument, pointed

at the sun and having an aperture of about ten solar diameters (a common aperture for most instruments used to measure "direct" insolation) is about 1 1/2% of the direct insolation. With intermittent thin clouds, the circumsolar radiation is considerably brighter.

Turbidity, caused by aerosols in the atmosphere, creates significant absorption and scattering because the aerosol particles are large with respect to the wave-length of solar radiation. Many of the aerosols are of natural origin such as those from volcanos, dust and particles of sea-salt. In densely populated areas, man made pollutants tend to be the dominant contributor to turbidity.

The term "Global Insolation" refers to the total solar energy received on a horizontal surface at the earth's surface.

BASIC INSTRUMENTS

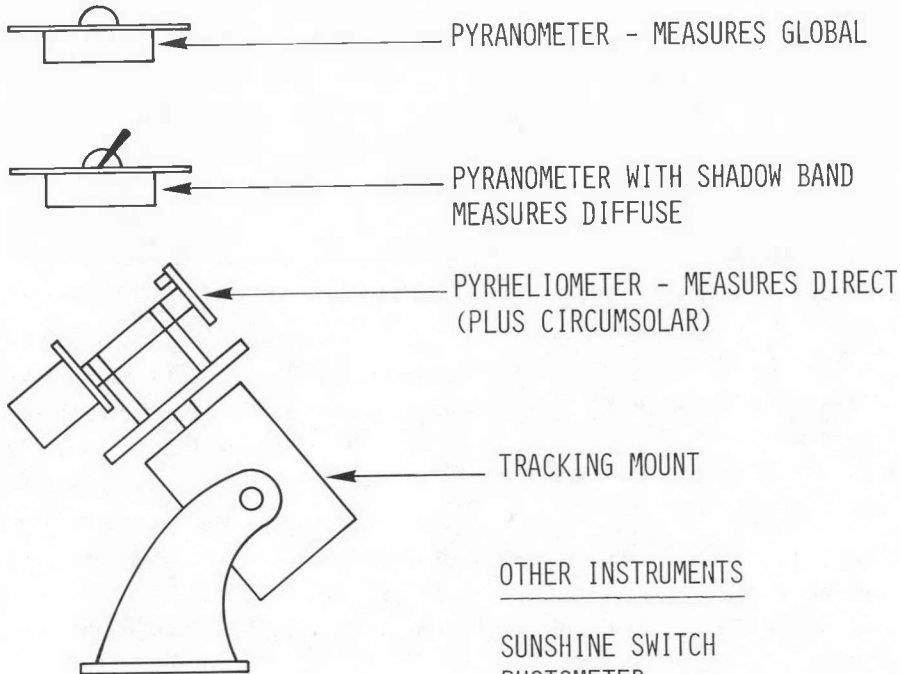

OTHER INSTRUMENTS

SUNSHINE SWITCH
PHOTOMETER
PHOTOSPECTROMETER

There are many specialized instruments for measuring solar phenomena, but this study is concerned only with those used to measure data for practical users of solar energy.

The most common instrument is the pyranometer. It is usually mounted horizontally and measures global insolation. Newer types of pyranometers may be mounted at any angle of inclination to measure the insolation that would be received by an inclined surface.

If the pyranometer is fitted with a shadow band adjusted to shade the sensing element from the direct insolation, it measures only the diffuse insolation. Thus two horizontal pyranometers, one fitted with a shadow band, permit determination of the direct and diffuse components of insolation. There are some problems with the shadow band - it obscures much more of the sky than just the solar disc, hence calibration is only approximate. Further, it must be frequently adjusted to compensate for changes in solar declination.

Pyrhelioscopes are normally constructed to view a small part of the sky so that they measure direct (beam) insolation. Because of the difficulty in maintaining exact alignment,

they are usually constructed to view a solid angle of about ten solar diameters and they therefore measure direct plus circumsolar radiation. Commonly available, inexpensive (\$1,300) tracking mounts for pyrhelioscopes are quite crude. They track at a mean solar time rate and do not automatically correct for changes in solar declination. They require frequent adjustment (from every few days during equinox to every few weeks during summer solstice.)

Other instruments of interest are sunshine switches which indicate the times when there is direct insolation- they are calibrated to turn off when they are shadowed. Their principal virtue is low cost and wide distribution. Sunshine switch data does not provide an adequate indication of insolation, but is helpful in interpolation between and among stations measuring insolation.

Photometers and photospectrometers are used to acquire special data. Currently available models are not suitable for unattended monitor stations.

At the outset of the study it appeared that instrument deficiencies were a significant problem. However, the errors inherent in available instruments are not large compared to the errors that can be introduced in translating their readings into useful information, the errors possible thru spatial interpolation between and among instrument sites, and the year to year variability of climate. Available instruments, installed with reasonable care and periodically calibrated can produce insolation data with an uncertainty of about $\pm 3\%$ including the errors introduced by signal conditioning equipment and recording devices.

There are too few stations in the US measuring insolation; about one station per 40,000 square miles. In particular, coverage of high population density areas, where the greatest application of solar energy is likely, is poor.

A major obstacle to the design of optimum systems is the lack of measured data for the direct and diffuse components of insolation. The error in predicted performance of a flat plate system that can result from using global insolation data and estimates of the diffuse and direct components of insolation is several times the error likely to be introduced by instrument inaccuracies.

High confidence design requires knowledge of the year to year variability of climate so that average and extreme conditions can be considered. The extreme conditions are of particular concern to the electric utility industry since they may have significant impact on load offset and peak demand.

Five user requirements have been identified for insolation (and correlated environmental data). There are probably others, but these are of primary interest to the electrical utility industry.

The evaluation of expected performance of a system design, given that the performance parameters of the several system components are known with acceptable accuracy, is dependent upon the determination of the input (insolation) simultaneously with demand (load). Performance evaluation is the most important requirement because it is inherent in the other four.

For future planning, and as an aid in identifying utility preferred systems, users need the ability to predict the impact, in terms of load offset and peak demand vs. time, of large numbers of solar energy systems in a service area. This can be done with modeling and simulation techniques similar to those for evaluation of individual systems, but modified to accommodate aggregations of many systems.

Should the impact prediction reveal adverse effects upon the utilities, the impact prediction models may be rerun with modifications to incorporate features designed to minimize adverse effects and to objectively determine the changes in impact. Modifications might include larger storage, incorporation of heat pumps, varying strategies for timed operation of auxiliary units, etc. The results would provide an objective basis for the support of rate structure changes or hook-up requirements.

Should the electrical utility become involved in the design of solar energy systems, the same data base needed for evaluation of system performance will be adequate to support the design function.

The last identified, but a very important function of the electric utility industry, is furnishing data and advice to subscribers as to the optimum uses of electrical energy in conjunction with solar energy systems.

REQUIREMENTS OF GENERIC SYSTEM TYPES

- DATA ELEMENTS
 - DIRECT AND DIFFUSE INSOLATION
 - RELATED DATA AFFECTING PERFORMANCE
 - DATA INFLUENCING LOAD

- CONTINUUM OF DATA
 - TIME PROBABILITY DISTRIBUTION
 - AVERAGES AND EXTREMES

- GEOGRAPHIC COVERAGE

- SPECIAL REQUIREMENTS FOR PHOTOVOLTAICS

Each generic system type has been evaluated for its response to environmental factors which influence energy delivered or load demand. These will be seen on the table which follows.

Not shown on the table is the requirement for continuous data and for sufficient geographic density to permit high confidence interpolation between observing stations.

The variability of climate requires a long period of observation to determine average and extreme conditions with acceptable confidence. To an individual homeowner an average winter may provide adequate information for an investment decision. For an electrical utility manager, data on extremes is of great importance in forecasting peak demands.

DATA REQUIREMENT CLASSIFICATION			ENVIRONMENTAL DATA	DIRECT INSOLATION TRANSIENTS IN DIRECT SPECTRUM OF DIRECT DIRECT + CIRCUMSOLAR	GLOBAL INSOLATION TOTAL INSOLATION, INCL. SPECTRUM OF TOTAL, INCL.	AVG. TEMPERATURE AVG. DEW POINT AVG. WIND WIND GUSTS
RELATIVE IMPORTANCE: 3 DOMINANT 2 SIGNIFICANT 1 MINOR						
GENERAL SYSTEM TYPE						
SOLAR THERMAL GENERATING PLANTS	CENTRAL RECEIVER	AIR COOLED	3 2 - -	- - -	2 1 2 2	
		WATER COOLED	3 2 - -	- - -	1 - 2 2	
	DISTRIBUTED	AIR COOLED	3 2 - -	- - -	2 1 1 1	
	COLLECTOR	WATER COOLED	3 2 - -	- - -	1 - 1 1	
INCLINED FLAT PLATE COLLECTORS			- - - -	- 3 -	2 - 1 -	
HORIZONTAL (POND) COLLECTORS			- - - -	3 - -	2 - 1 -	
LOW RATIO CONCENTRATOR			- - - 3	- - -	1 - 1 1	
PHOTOVOLTAIC, CONCENTRATING			3 2 2 -	- - -	1 - 2 2	
PHOTOVOLTAIC, NON-CONCENTRATING			- - - -	- 3 2	1 - 1 -	
AVAILABILITY OF ENVIRONMENTAL DATA	EXISTING SOURCES		- - - X	X - -	X X X X	
	DIRECTLY MEASURABLE		- X X X	X X X	X X X X	
	ESTIMATED		X - X -	X X		

The upper three-fourths of the table show the relative importance of environmental data for estimating the performance of several types of solar energy systems. The factors influencing load are not shown, they are determined by the application of the solar energy. However, it is important that factors influencing load be time correlated with those influencing performance.

The lower section shows the availability of data on the various parameters of interest. Note that global insolation data, which is available for many sites, is directly

applicable only to horizontal ("pond") collectors; and that total insolation on an inclined surface, which represents the greatest current need, is not available. It can be accurately determined if both global and direct (or diffuse) are known, but such long term measurements are virtually non-existent. We did not classify direct insolation as a measurable quantity because we are interested in relatively simple unattended monitoring stations, and the type of tracking mount required is prohibitively expensive.

The primary source of environmental data is that compiled by the National Weather Service over the past 20 years. Seventy-seven sites in the contiguous U.S. have measured insolation data, but there has been inadequate quality control. Errors are estimated to range from +5% to +30%. The poor accuracy of the data led to a decision in 1972 to cease publication until the network could be upgraded.

Most of the data is global. A few sites recorded direct insolation at selected times each day.

The quality of the data is poor, but the records are largely continuous and there are techniques available that will permit derivation of approximate calibration curves for the instrument. Rehabilitation of the data base to make it usable will be an expensive process. NWS has proposed a program to accomplish the rehabilitation and some work may have been started.

SCOPE OF NWS DATA

OLD DATA BASE

GLOBAL DATA	HOURLY	19 SITES,	1967-1972
	DAILY	ALL SITES,	1952-1972
"DIRECT"	HOURLY	4 SITES,	1967-1972

POST-1975 PROGRAM

GLOBAL DATA	HOURLY	35 SITES
DIRECT	HOURLY	5 SITES
GLOBAL & DIFFUSE	HOURLY	7 SITES *

FUTURE - PROPOSED EXPANSION TO 90-100 SITES

* 3 ADDITIONAL COLOCATED WITH SITES
MEASURING DIRECT

A detailed inventory of NWS insolation data is available showing exact dates, significant gaps, recording format, etc. Here is a brief summary of data of interest. Note that the current program is greatly reduced in scope and that its expansion is dependent upon future funding.

DEFICIENCIES

- ACCURACY
 - LARGELY UNKNOWN, BUT LITTLE CONFIDENCE IN EXISTING DATA BASE
- DATA ELEMENTS
 - PREDOMINATELY GLOBAL INSOLATION DATA
- GEOGRAPHIC COVERAGE
 - POOR IN AREAS OF GREATEST INTEREST (HIGH POPULATION DENSITY)

The deficiencies in the NWS data base have been pointed out earlier. There is a remedy to improve the accuracy of the older data, but even then two serious deficiencies remain. The global data, even if absolutely accurate, cannot be translated into the energy available to an

inclined flat plate collector without making an assumption as to the direct and diffuse components - and we do not have an accurate method for estimating the components. Further, the data is geographically sparse, particularly in high population density areas.

TRANSLATION OF GLOBAL
TO INCLINED

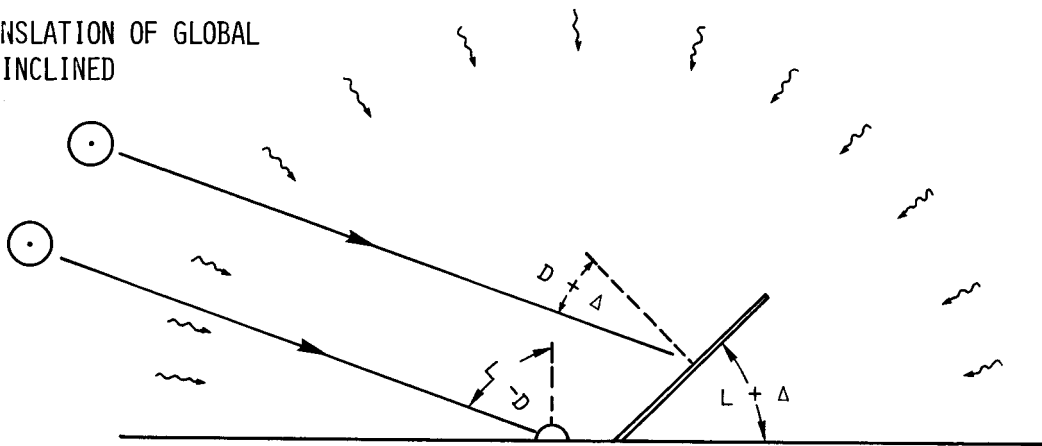

$$I_G = \frac{\text{DIFFUSE}}{\text{TOTAL}} + 1 - \frac{\text{DIFFUSE}}{\text{TOTAL}} \cos(L-D)$$

$$I_C = \frac{\text{DIFFUSE}}{\text{TOTAL}} \cdot \frac{180-(L+\Delta)}{180} + 1 - \frac{\text{DIFFUSE}}{\text{TOTAL}} \cos(D+\Delta)$$

$$\frac{DI_C}{D \text{ DIFFUSE}} = \frac{180-(L+\Delta)}{180} - \frac{\cos(D+\Delta)}{\cos(L-D)}$$

This chart illustrates the difficulty in correcting global insolation into that available to an inclined collector. If we have only global insolation (I_G) data we know that the value includes all of the diffuse and the direct normal incidence insolation (that which would be received on a plane normal to the earth-sun line) times the cosine of the sun's zenith angle (Latitude minus solar declination at solar noon).

But to convert I_G to that available to a collector oriented to an inclination of

Latitude plus some angle ($L+\Delta$), we must multiply the diffuse component by $180 - (L+\Delta)/180$ and the direct component by cosine (declination plus Δ). The foregoing assumes diffuse insolation to be isotropic --on a clear day it isn't--in the presence of clouds and for long integration periods it is nearly isotropic.

The consequence of an error in estimating the direct and diffuse components of insolation are shown on the next chart.

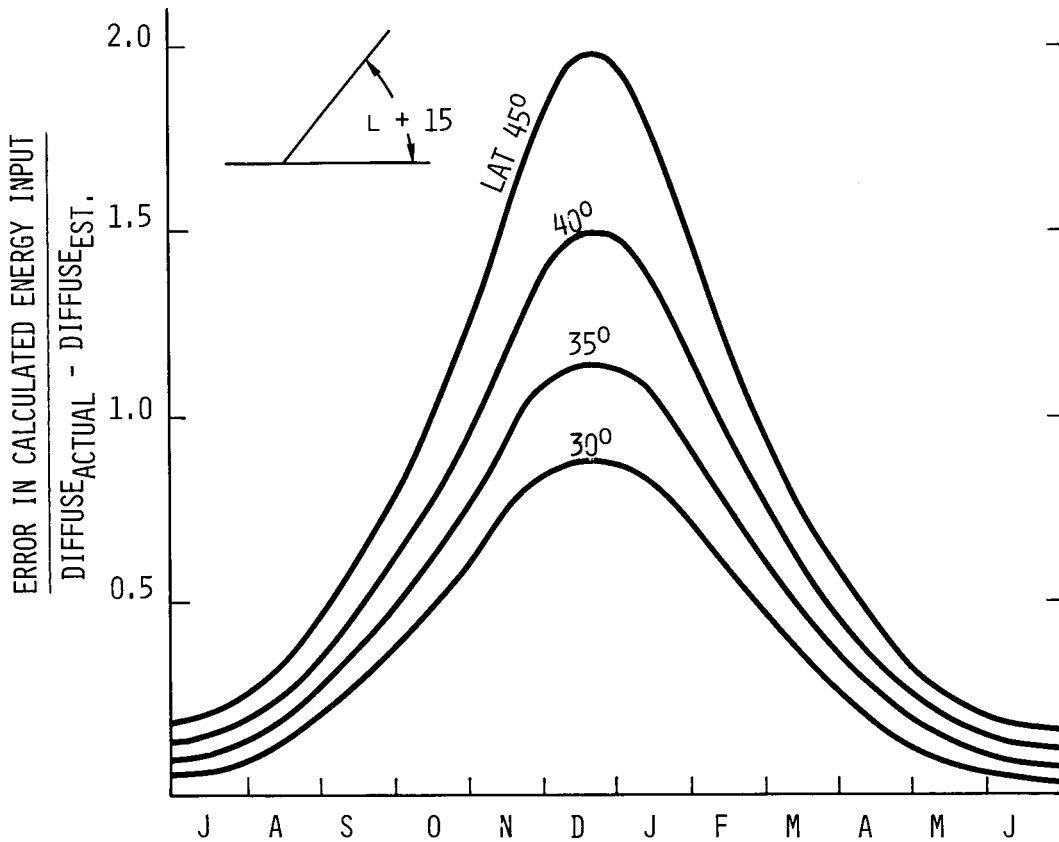

Here is shown the ratio of the error in the calculated performance of a flat plate collector inclined to $L+15^\circ$ (about optimum for solar heating) to the percentage difference between actual and estimated diffuse insolation applied to global data to determine the direct and diffuse components.

If one assumed the diffuse component to be 25% when in fact it was 35% of total insolation, then the calculated input to a

collector at Minneapolis (Lat 45°N) on 21 December would be 20% greater than actual. Note that the error is large only when it counts--during the peak heating season.

The graph is based upon an approximation which is valid only at noon. During the winter months the actual error will be larger than shown. In the summer the actual error will be smaller than shown.

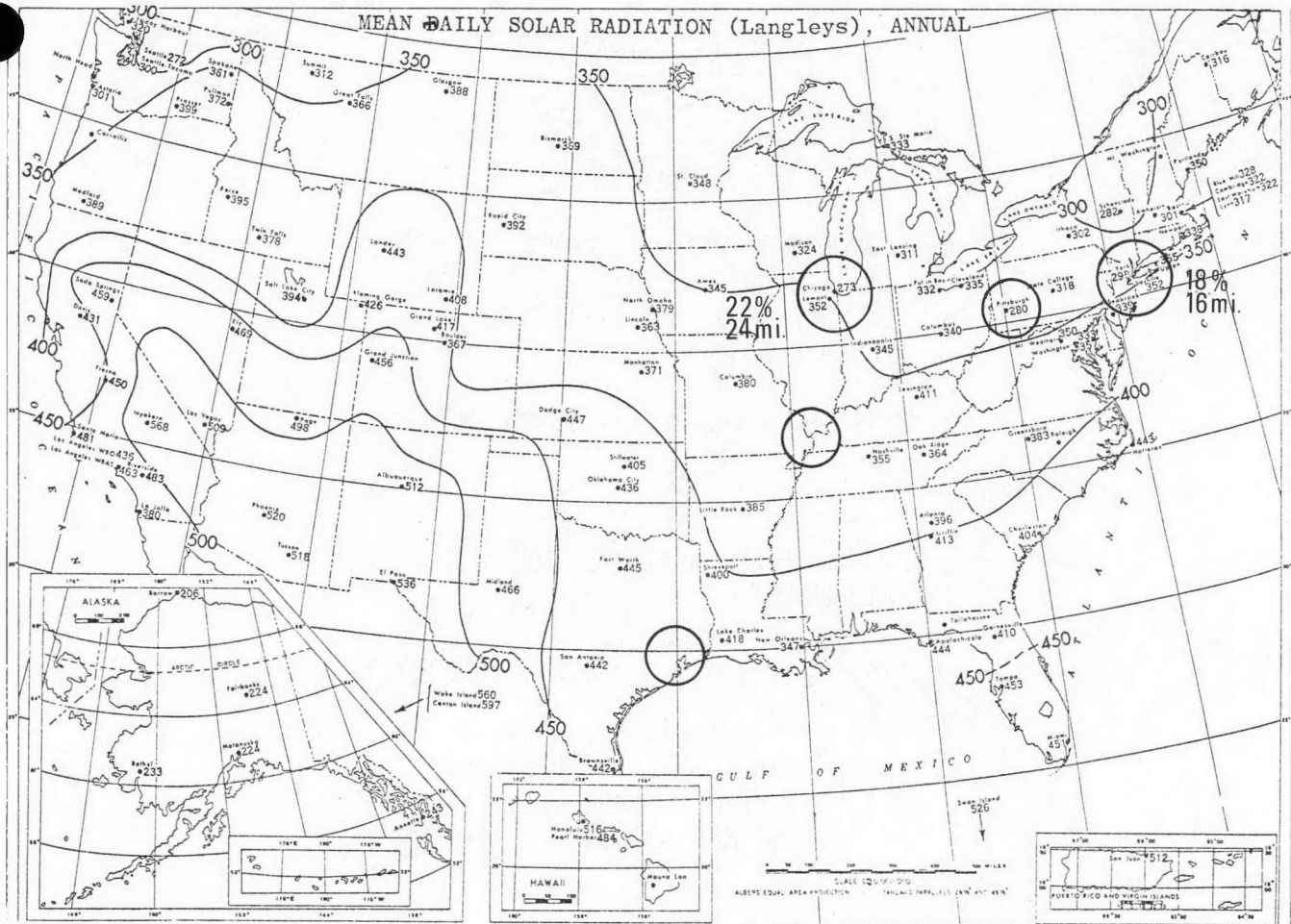

This map is from the National Climatological Atlas of the US. It has many shortcomings. Not only is it developed from suspect data, but it reflects only data up to 1962.

The contours show annual average daily insolation in Langley's (one gram-calorie per cm^2) incident on a horizontal surface.

Despite the shortcomings, the map suggests that higher density coverage is needed. Note the two readings in the Chicago area which show a difference of 22% in 24 miles. Most of us are aware of the "lake-front" effect in Chicago, but there is little objective data on which to base insolation contours for the area. A similar case exists in the New York area where the difference is 18% in 16 miles. Again, this isn't surprising in view of the New York air pollution, but it makes the application of existing data questionable in the area. Nor will it surprise anyone to note that the reading at Pittsburg is

inconsistent with the general contours.

Note also the many metropolitan areas for which no data is available. It is possible that data from the EPA Regional Air Pollution Monitoring System in the St. Louis Area will permit an assessment of the density of measurements needed to determine optimum sizing in a typical metropolitan area.

Another caution about using contours of the type shown on this map - the apparent large differences in insolation with Latitudes are not as great as the contours indicate, because at higher latitudes the gain available from tilting a collector to an optimum angle is greater than at lower latitudes. However, to construct a map showing, say, insolation available to a south-oriented collector incline to L, would require observed data at that inclination or a knowledge of the direct and diffuse components of global data.

WORTH OF ACCURACY

DIFFICULT TO ASSESS WITH PRECISION

- RANDOM OR SYSTEMATIC ERRORS
- INTEREST & FUEL INFLATION RATES
DOMINATE SOLAR SYSTEM COST FACTORS
- SMALL ECONOMIC IMPACT FOR ANY ONE USER

ONE EXAMPLE

EVALUATION OF HHW MODELS (BOSTON-RALEIGH -
ALBUQUERQUE) AT:

NWS INSOLATION LEVELS
.95 AN 1.05 TIMES NWS LEVELS

SHOWS CALCULATED ERROR IN
ANNUAL FUEL SAVINGS ABOUT
\$5 PER 1% ERROR IN INSOLATION
ESTIMATE (\$5.50/MBTU FUEL COST)

It is very difficult to put a price on the value of more accurate insolation data. We do not know if the errors have a consistent basis or are random. If the latter, the overall consequences are probably small.

It is not certain that moderate uncertainties as to the insolation available would have a substantial influence on decisions to invest in a solar energy system because interest rates and fuel inflation factors tend to dominate the annual cost computations.

To gain some insight into the economic impact of uncertainty in insolation, three HHW models were postulated and their performance estimated for the monthly average insolation and degree days shown in the Climatic Atlas

of the US and for insolation values five percent greater and five percent less. On the average, the sensitivity of annual fuel savings was about one dollar per year per percent difference in insolation multiplied by the fuel cost per MBTU. Thus, a 5% difference in insolation for a user paying \$5.50 per MBtu for fuel made about a \$27 difference if only in annual fuel savings.

This small difference in annual savings, however, could lead to a fairly substantial inappropriate investment if the estimated annual interest rate (approximately the annual interest for a loan minus the estimated annual inflation rate for fuel) were favorable.

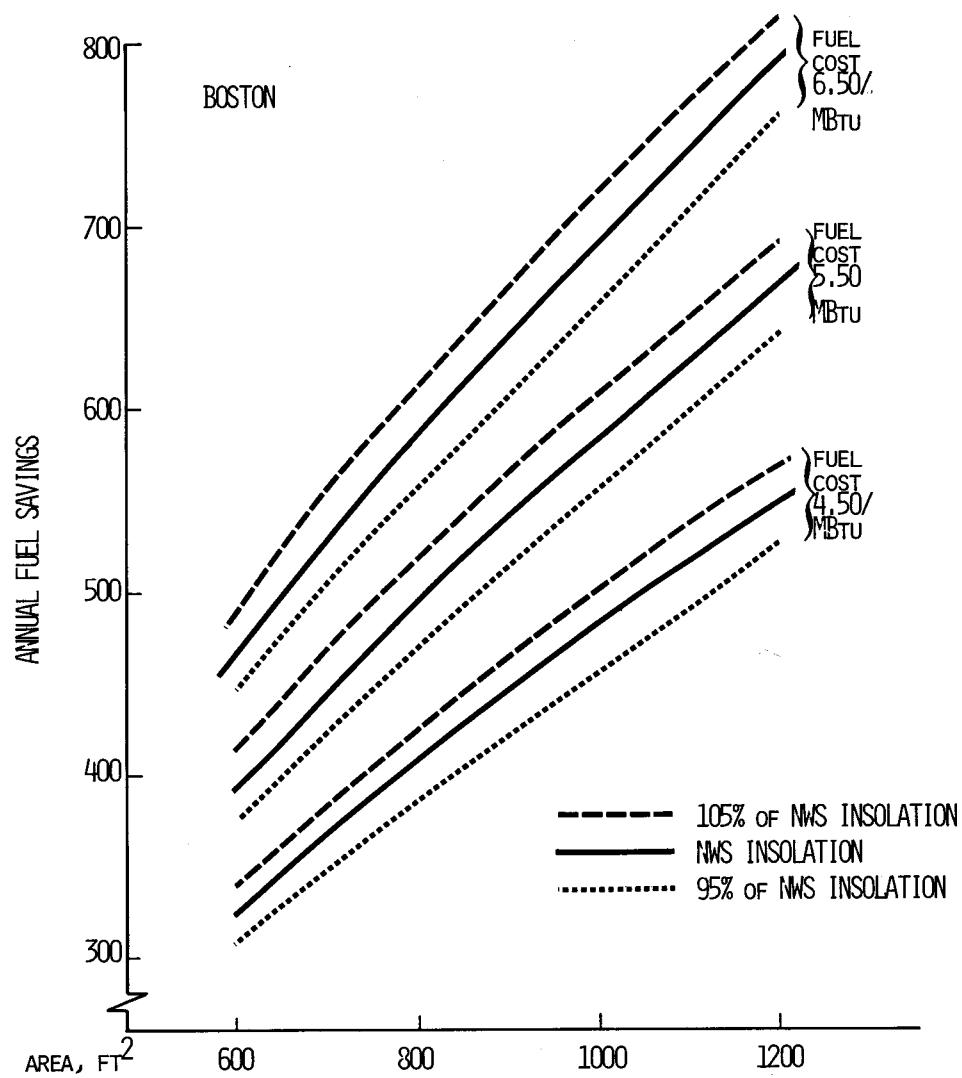

The graph shows the results of the analysis for one of the models. Note that the differences in annual savings is not markedly sensitive to systems size.

MONITORING STATIONS

INVESTMENT - INSTRUMENTS
SIGNAL CONDITIONING
RECORDERS
SITE IMPLEMENTATION

ANNUAL O&M - SITE VISITS
TAPE TRANSLATION
CALIBRATION
REPAIRS

TYPICAL STATION COSTS 5-12K

TYPICAL ANNUAL O&M 1-2K/STATION

Monitoring stations for the acquisition of environmental data are not complex, but the requirement for automatic recording of data from several instruments, and the need for frequent visits to clean instrument covers and check operation makes their total cost quite high. Two examples are shown on the following charts.

BASIC MONITORING STATION

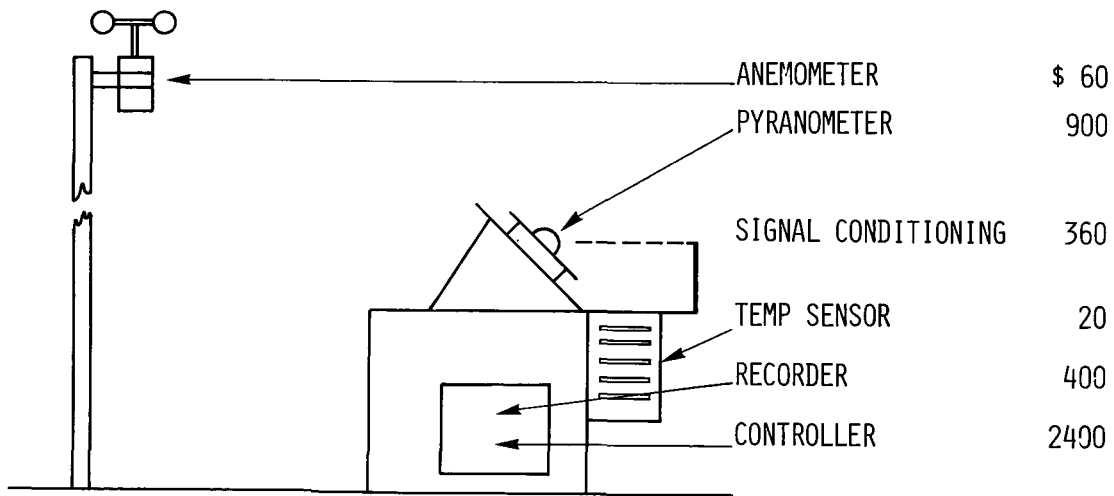

SITE SURVEY, DRAWINGS, FOUNDATION,
MOUNT, HOUSING, MAST & STAYS CABLE,
MISC HARDWARE, INSTALLATION AND
CHECK OUT

INVESTMENT

1600
5740

SITE VISITS, TAPE TRANSLATION
MAINTENANCE & CALIBRATION

1010/YR

This represents a *minimum* monitoring station. It measures wind speed, temperature, and insolation received at an inclination equal to Latitude. While it does not provide data on the direct and diffuse components of insolation, the reading of the inclined instrument can be translated into insolation available to a collector at a similar inclination without risk of large errors. Note that a horizon screen is used to eliminate site albedo so that insolation data can be better interpolated between stations. An electronic

controller is included to ensure that data is recorded at the desired intervals and to time stamp each data block. Continuous recording of each instrument on multi-channel tapes would eliminate the need for the controller but would increase costs for signal conditioning and tape translation. It is assumed that most site visits for cleaning the pyranometer dome and checking for correct operation are made by on-site personnel and do not incur any identifiable cost.

INTERMEDIATE MONITORING STATION

	ANEMOMETER	60
	TWO PYRANOMETERS	1800
	SIGNAL CONDITIONING	720
	TEMP SENSOR	20
	DEW POINT SENSOR	125
	RECORDER	400
	CONTROLLER	2400
	STATION IMPLEMENTATION	1600
	INVESTMENT	7125
	SITE VISITS, TAPE TRANSLATION	
	MAINTENANCE & CALIBRATION	1135/YR

This sketch shows a station which measures both global and diffuse insolation, windspeed, temperature and dew point. The acquisition of simultaneous data on global and diffuse insolation is important for two reasons: it permits accurate determination of the insolation

available to any type of collector and it provides a basis for the interpretation of older data which is mostly global. The shadow band pyranometer is preferable to a tracking pyrheliometer because it does not require a special tracking mount and it need not be adjusted as frequently.

ALTERNATIVES

- DO NOTHING - RELY ON DEVELOPMENT OF DATA
BY ERDA, ASHRAE & SOLAR ENERGY
SYSTEM MANUFACTURERS

- PRO - LOWEST VISIBLE COST

- CON - NO CONTROL OF QUALITY (CONFIDENCE)

- PROLONGED WAIT FOR ANY USEFUL DATA

The electrical utility industry has several alternatives for acquiring data to satisfy user needs. A passive role is not out of the question since the current interest in solar energy is almost certain to result in increases in

monitoring efforts and data analysis. While a passive approach involves no directly identifiable cost, it does not provide for influence over the quality of the data. Nor is there any assurance that data for areas of primary interest will be available when required.

ALTERNATIVES (CON'T)

- REHABILITATE OLD NWS DATA BASE
- DEVELOP CLIMATIC CLASSIFICATIONS & SCALING FACTORS, DETERMINE AVERAGES AND DISTRIBUTION
- DEVELOP METHODS FOR UPDATING & REFINING RESULTANT INFORMATION

PRO - EARLY ACQUISITION OF USEFUL DATA
ONLY SOURCE OF HISTORICAL DATA

CON - ONLY MODERATE ACCURACY (MOSTLY
GLOBAL DATA - HIGHLY AGGREGATED)
- EXPENSIVE (≈ \$850K)

A viable alternative is to establish a data base using the rehabilitated NWS data, analyze this data to determine averages and extremes and to develop climatic classification and scaling factors that will facilitate system performance evaluations without the need for hour-by-hour simulations based on actual observed data.

Some provision must be made for updating the data base as additional data of greater known accuracy become available.

The data base would have several serious shortcomings. Most of the data are global and large errors are possible in translating it to insolation available to inclined collectors. Most is based upon daily totals and is not directly usable for systems with relatively small storage capacities. Finally, the rehabilitation and analysis of the NWS data base would be costly.

ALTERNATIVES (CON'T.)

- AFTER REHAB OF NWS DATA BASE UPDATE
& REFINE WITH NEW NWS DATA

PRO - LOW COST (DATA PROCESSING ONLY)

CON - INADEQUATE GEOGRAPHICAL DENSITY
LEAST USEFUL DATA (MOSTLY GLOBAL)
NO CONTROL OVER QUALITY (CONFIDENCE)
NETWORK EXPANSION NOT CERTAIN

REMEDIES - AUGMENT NWS NETWORK

MEASUREMENT OF GLOBAL & DIFFUSE
HIGH DENSITY COVERAGE OF
POPULATION CENTERS

MINIMUM USEFUL AUGMENTATION
COST 334K + 49K/YR.

Despite the shortcomings of a data base derived from the NWS records, it is the only source of a long time record, and its development is recommended.

Continual refinement thru the introduction of new data acquired by the NWS would result in gradual improvement in both accuracy and usefulness. The principal disadvantages to sole reliance on NWS data are the sparcity of geographic coverage and the dominance of global data.

A remedy is available through augmentation to fill gaps in coverage areas and to acquire data on the components of insolation to enable more accurate interpretation of global data.

It is suggested that multiple monitor stations be placed in about five metropolitan areas to verify the feasibility of interpolation on a micro climatic basis, and that about twenty stations making simultaneous measurements of global and diffuse be implemented to develop techniques for accurate interpretation of global data.

The cost of 40 monitor stations and central data processing is estimated at about \$334K. The annual operation and maintenance cost would be about \$49K. It would take several years of operation to assess the utility and adequacy of the augmentation stations.

ALTERNATIVES (CON'T.)

- AFTER REHAB OF NWS DATA BASE UPDATE
& REFINE WITH UTILITY OPERATED NETWORK

PRO - SELECTIVE GEOGRAPHIC COVERAGE
MEASURE ONLY MOST USEFUL DATA
QUALITY CONTROL
ASSURED IMPLEMENTATION

CON - MINIMUM USEFUL NETWORK
COST \approx 830K PLUS 131K/YEAR

If complete control over quality, format and location is desired, it would be necessary for the electric utility industry to field an entire network of monitor stations. A minimum network comprised 20 stations for high density coverage of five selected metropolitan areas, 40 stations measuring both global and diffuse, six desert stations measuring direct and global, and 74 stations measuring total insolation at an inclination equal to latitude would provide a spatial

density about 150% greater than the former NWS network and would permit verification of the feasibility of microclimatic interpolation in high population density areas.

The primary advantages of the utility operated network are the selective geographic coverage and the acquisition of only the most useful data. The cost would be about \$830K (current dollars) for implementation and \$131K per year for operation and maintenance.

DATA MANAGEMENT

CENTRAL FACILITY

ENABLES INTERPOLATION
FACILITATES ANALYSIS
REVEALS GAPS
SIMPLIFIES INPUT OF DATA FROM OTHERS

REQUIRES - CENTRAL MANAGEMENT
STANDARDIZATION

INDIVIDUAL UTILITY

LOCAL AREA INTERPOLATION ONLY
DUPLICATION OF EFFORT
DIFFICULT TO INTEGRATE DATA

Regardless of the alternative selected, a plan for data management must be prepared at the outset. There are definite advantages to the use of a central facility to process the data and translate it into directly useful information.

The most significant advantage is in the ability to interpolate for any point in the network coverage and the detect patterns that may ultimately permit reducing the size of the network or indicate the need for change in geographic coverage to make

more accurate interpolation possible.

A central facility infers central management and standardization of station configurations, recording formats and recording intervals.

Management of data by the individual utilities obviates the need for central management, but any savings therefrom may be offset by the duplication of effort involved in developing processing and analysis.

INCREMENT			CUMULATIVE COST (000) END OF YEAR N						
ITEM	INV	O&M	1	2	3	4	5	6	7
PREREQUISITE	880	-	880	880	880	880	880	880	880
DATA PROCESSING FAC	-	74	-	74	148	222	296	370	444
AUGMENTATION 1-A	172	26	-	198	224	250	276	302	328
AUGMENTATION 1-B	162	23	-	-	185	208	231	254	277
AUGMENTATION 1-C	52	-	-	-	52	52	52	52	52
AUGMENTATION 1-D	46	4	-	-	-	50	54	58	62
TOTALS	1,312	127	880	1,152	1,489	1,662	1,789	1,916	2,043

TABLE 8-1 REVISED CUMULATIVE COST OF ALTERNATIVE 1
WITH PHASED AUGMENTATION

This table shows the seven year cumulative cost of alternative 1 (using NWS data and augmenting the network for measurement of components, and high density coverage of selected metropolitan areas.) The entire cost of rehabilitation and analysis of the NWS data is included although it appears appropriate that other agencies should share this cost.

Two minor augmentations are also

shown. Augmentation 1-C is the accurate measurement of circumsolar radiation to gain insight into the possible need for such data on a continuing basis. Augmentation 1-D is the retrofit of monitor stations with photovoltaic devices. Such a retrofit cannot be made until there is high confidence in the spectral response of the solar cells type most likely to be used for large scale direct conversion.

INCREMENT			CUMULATIVE COST, END OF NTH YEAR (000)						
ITEM	INV	O & M	1	2	3	4	5	6	7
Prerequisite	880	-	880	880	880	880	880	880	880
Data Processing Fac.	-	74	-	74	148	222	296	370	444
Executive Secy Office	-	40	40	80	120	160	200	240	280
System Deployment ϕ 1	283	46	-	329	375	421	467	513	559
ϕ 2	270	42	-	-	312	354	396	438	480
ϕ 3	278	43	-	-	-	321	364	407	450
Augmentation 2-A	52	-	-	-	52	52	52	52	52
Augmentation 2-B	48	4	-	-	-	50	54	58	62
TOTALS	1,811	249	920	1,363	1,887	2,460	2,709	2,958	3,207

TABLE 8-2. CUMULATIVE COST OF ALTERNATIVE 2
WITH PHASED AUGMENTATION

This table shows the cumulative costs for alternative 2, the utility operated network. Again, the entire cost of rehabilitation and analysis of the NWS data is included. Some savings obtainable from large scale equipment purchases are reflected in this table.

The two small augmentations, 2-A and 2-B are the same as 1-C and 1-D shown for alternative 1.