

WRRI--140

DE83 900302

BIOLOGICAL PROCESSES FOR
CONCENTRATING TRACE ELEMENTS FROM
URANIUM MINE WATERS

Corale L. Brierley, Ph.D., Chemical Microbiologist

James A. Brierley, Ph.D., Microbiologist

Technical Completion Report

Project No. 1345639

New Mexico Water Resources Research Institute
in cooperation with
New Mexico Bureau of Mines and Mineral Resources
and
Department of Biology
New Mexico Institute of Mining and Technology
Socorro, New Mexico

December 1981

The work on which this publication is based was supported in part by funds provided through the New Mexico Water Resources Research Institute by the United States Department of the Interior, Office of Water Research and Technology, as authorized under the Water Research and Development Act of 1978, P.L. 95-467, and by the state of New Mexico through state appropriations under Project No. 1345639.

DISCLAIMER

This report was prepared as an account of work sponsored by an agency of the United States Government. Neither the United States Government nor any agency thereof, nor any of their employees, makes any warranty, express or implied, or assumes any legal liability or responsibility for the accuracy, completeness, or usefulness of any information, apparatus, product, or process disclosed, or represents that its use would not infringe privately owned rights. Reference herein to any specific commercial product, process, or service by trade name, trademark, manufacturer, or otherwise does not necessarily constitute or imply its endorsement, recommendation, or favoring by the United States Government or any agency thereof. The views and opinions of authors expressed herein do not necessarily state or reflect those of the United States Government or any agency thereof.

DISCLAIMER

Portions of this document may be illegible in electronic image products. Images are produced from the best available original document.

The purpose of WRRI technical reports is to provide a timely outlet for research results obtained on projects supported in whole or in part by the Institute. Through these reports, we are promoting the free exchange of information and ideas and hope to stimulate thoughtful discussion and action which may lead to resolution of water problems. The WRRI, through peer review of draft reports, attempts to substantiate the accuracy of information contained in its reports; but the views expressed are those of the author(s) and do not necessarily reflect those of the WRRI or its reviewers.

Contents of this publication do not necessarily reflect the views and policies of the United States Department of Interior, Office of Water Research and Technology, nor does mention of trade names or commercial products constitute their endorsement or recommendation for use by the United States Government.

TABLE OF CONTENTS

	<u>Page</u>
List of Tables	v
List of Figures	vi
Abstract	1
Introduction	5
Background	5
Objectives	6
Field Site	7
Report Presentation	7
Water and Sediment Chemistry of a Uranium Mine Wastewater Treatment Facility	10
Materials and Methods	10
Sample Collection	10
Collection of Field Data	11
Analyses	11
Solids Processing	11
Analytical Procedures for Aqueous Samples	12
Results and Discussion	13
Mine Waters	13
Temperature	13
pH, Eh and Dissolved Oxygen	13
Conductivity	16
Sulfate and Radium	16
Uranium	21
Molybdenum	24
Selenium	26
Copper, Iron and Vanadium	28
Nitrate and Phosphate	28
Suspended Particulates	31
Total Suspended Solids	31
Uranium, Molybdenum and Selenium	34
Sediments	34
Uranium, Selenium and Molybdenum	34
Copper, Iron and Vanadium	36
Sulfur	36
Core Samples	38
Conclusions	40
Removal of Uranium and Molybdenum from Wastewaters by Algae	42
Introduction	42
Materials and Methods	43
Site Description	43
Collection and Laboratory Culture	44
Algae Digestions	45
24-Hour Uptake Experiments	45
Long-Term Experiments	46

	<u>Page</u>
Analytical Procedures	47
Results	47
Uranium and Molybdenum in Field-Collected Algae	47
24-Hour Uptake Experiments	50
Long-Term Experiments	52
Discussion	60
Bacterial Mechanisms for Removal of Selected Inorganic Pollutants from Uranium Mine Wastewater	 68
Introduction	68
Materials and Methods	70
Results	71
Bacterial Populations	71
Laboratory Model-Ecosystem	74
Discussion	77
Summary	79
References	82
Appendix	91

LIST OF TABLES

<u>Table</u>		<u>Page</u>
I	Temperatures of waters collected over a 4-year period from a uranium mine water treatment facility near Grants, New Mexico	14
II	pH of waters collected over a 3-year period from a uranium mine water treatment facility near Grants, New Mexico	15
III	Eh of waters collected over a 3-year period from a uranium mine water treatment facility near Grants, New Mexico	17
IV	Dissolved oxygen in waters collected over a one-year period from a uranium mine water treatment facility near Grants, New Mexico	18
V	Conductivity of waters collected over a 3-year period from a uranium mine water treatment facility near Grants, New Mexico	19
VI	Sulfate concentration in waters collected over a 3-year period from a uranium mine water treatment facility near Grants, New Mexico	20
VII	Radium concentrations in selected water samples collected October 19, 1978, from a uranium mine water treatment facility	22
VIII	Uranium concentrations in waters and sediments collected over a 3-year period from a uranium mine water treatment facility near Grants, New Mexico	23
IX	Molybdenum concentrations in waters and sediments collected over a 4-year period from a uranium mine water treatment facility near Grants, New Mexico	25
X	Selenium concentrations in waters and sediments collected over a 4-year period from a uranium mine water treatment facility near Grants, New Mexico	27
XI	Copper, iron and vanadium concentrations in waters and sediments collected over a one-year period from a uranium mine water treatment facility near Grants, New Mexico	29
XII	Nitrate concentration in waters collected over a 2-year period from a uranium mine water treatment facility near Grants, New Mexico	30
XIII	Phosphate concentrations in waters and sediments collected from a uranium mine water treatment facility near Grants, New Mexico	32
XIV	Total suspended solids in waters collected over a 4-year period from a uranium mine water treatment facility near Grants, New Mexico	33

<u>Table</u>	<u>Page</u>
XV	Total sulfur concentration in sediment samples collected over a two-year period from a uranium mine water treatment facility near Grants, New Mexico 37
XVI	Chemical analyses of core samples collected from the basin of Algae Pond #2 of a uranium mine water treatment facility 39
XVII	Uranium and molybdenum levels in field-collected algae 48
XVIII	Uranium and molybdenum levels in field-collected algae (data from three ponds averaged) 49
XIX	24-hour uptake of Mo and U by <u>Chara</u> and <u>Spirogyra</u> 51
XX	Uptake of U and Mo by <u>Chara</u> and <u>Spirogyra</u> (Long-term Experiment I) 53
XXI	Uptake of U and Mo by <u>Chara</u> and sediment in darkened cultures (Long-term Experiment II) 54
XXII	Eh measurements of <u>Chara</u> and sediment in darkened cultures (Long-term Experiment II) 57
XXIII	Percent of the U and Mo removed by <u>Chara</u> and sediment in darkened cultures (Long-term Experiment II) 59
XXIV	Bacterial populations present in minewater and pond sediments 72
XXV	Comparison of total-count of microorganisms with concentration of <u>Flavobacterium</u> species 73
XXVI	Decrease of selected soluble pollutants in a sediment-water system 75

LIST OF FIGURES

<u>Figure</u>	<u>Page</u>
1	Schematic of settling ponds for Kerr-McGee Corp. sections 35 and 36 wastewaters 8

ABSTRACT

Wastewater from uranium mines in the Ambrosia Lake district near Grants, New Mexico, U.S.A., contains uranium, selenium, radium and molybdenum. The Kerr-McGee Corporation has a novel treatment process for waters from two mines, sections 35 and 36, to reduce the concentrations of the trace contaminants. Particulates are settled by ponding, and the waters are passed through an ion exchange resin to remove uranium; barium chloride is added to precipitate sulfate and radium from the mine waters. The mine waters are subsequently passed through three consecutive algae ponds prior to discharge. Water, sediment and biological samples were collected over a 4-year period and analyzed to assess the role of biological agents in removal of inorganic trace contaminants from the mine waters.

Conclusions derived from chemical analyses of waters and sediments of the mine water treatment facility are:

1. The concentrations of soluble uranium, selenium and molybdenum were not diminished in the mine waters by passage through the series of impoundments which constituted the mine water treatment facility. Uranium concentrations were reduced but this was due to passage of the water through an ion exchange column.
2. The particulate concentrations of the mine water were reduced at least ten-fold by passage of the waters through the impoundments. Since uranium, selenium and molybdenum were associated with the suspended particulates, reduction in the concentration of total suspended solids

reduced the concentration of contaminants in the final effluent.

3. The ponds were well oxygenated. This was probably due to the shallow depth of the ponds and growth of algae.
4. The pH remained near neutral during all collections and this would indicate that the major soluble species of trace contaminants would be molybdate, uranyl carbonate species, selenite (and possibly selenate at the higher pH values).
5. The temperature remained higher than 10°C in winter suggesting that plant and microbial life could remain viable and that the volume of water was great enough to lessen large temperature fluctuations.
6. Phosphate and nitrate were present in high enough concentrations to support limited algal and microbial activity.
7. The sediments were anoxic and enriched in uranium, molybdenum and selenium. The deposition of particulates and the formation of insoluble compounds were proposed as mechanisms for sediment enrichment.

Algal populations in the mine water treatment facility were identified and their contribution in removal of inorganic trace contaminants was assessed by field and laboratory studies. The predominant algae identified in the impoundments were the filamentous algae Spirogyra and Oscillatoria, and the benthic alga, Chara. Seasonal variations in both uranium and molybdenum levels in the filamentous algae were observed in field-collected

samples. This suggested that adsorptive processes were important in the accumulation of the metals in the algae cells, since extent of adsorption depends not only on the amount of metal available per unit of surface area but also on the length of exposure of the surface to the metal. The results of 24-hour uptake experiments in the laboratory supported the field evidence. Short-term uptake of uranium and molybdenum was not observed in Chara, which accumulated both metals at much lower levels than the filamentous algae in the field. In the Spirogyra 24-hour test, the cell material showed a limited capacity to adsorb molybdenum, while uranium uptake increased with higher external concentrations.

The long-term laboratory studies indicated that the pond algae, in the form of particulate, decaying material, can be instrumental in removing metals from solution. However, the patterns of retention and release of uranium and molybdenum as the algae decayed in the presence of sediment indicated that maintenance of reducing conditions in the sediment or in the algal cultures was critical to the sequestering of the metals. The implication from the laboratory studies is that, while the algae are instrumental in removing metals from solution, the process was reversible unless the system contained substantial organic material. Also, while organic material accelerated the rate of removal and sometimes the extent of removal from water, retention of the metals in sediments was also reversible unless the system contained a high volume of sediment. These conclusions point to major problems in improving the existing pond system in respect to removal of uranium and molybdenum. Calculations of existing pond

productivity and the current removal of uranium and molybdenum by the algae present indicated that both greater algal populations and pond areas are necessary for removal of the trace contaminants.

Large populations of microorganisms were found in the waters pumped from the uranium mines and water passing through the pond system. Of particular interest was the presence of the sulfate reducing bacteria, believed to be Desulfovibrio and/or Desulfotomaculum. Laboratory experimentation indicated that the sulfate-reducing bacteria may have a role in removal of uranium, selenium, and possibly molybdenum from solution. Sulfide production by the organisms may be important since molybdenum can be precipitated as a sulfide. The reducing conditions may be responsible for converting soluble hexavalent uranium to the insoluble quadrivalent form. Although a large population of sulfate-reducing bacteria was found in the pond sediments, there was no decrease of soluble sulfate, which remained at 700 ppm in the water flowing through the system. Reduced forms of sulfur may be oxidized by the aerobic thiobacilli in oxidizing regions, returning the sulfur to the soluble sulfate species. The system may be nutrient limited and the activity of the sulfate-reducing bacteria quite slow.

INTRODUCTION

BACKGROUND

In most hardrock mining operations the mines are de-watered, i.e. water is pumped from the mines to prevent flooding of operations. This water often contains low concentrations of the elements being mined as well as other associated ions. In some cases, these waters must be treated to meet EPA standards before being discharged. Some of the mine waters are used in milling processes, and become even more laden with soluble inorganic ions. These brines are pumped to tailings ponds for evaporation or eventual release to surface or ground water systems. Both mine waters and tailings solutions are valuable sources of metals and other ions, and it is both economically and environmentally sound to recover these elements. In New Mexico industries which must remove inorganic agents from large volumes of water are the uranium and molybdenum operations. Although precipitation, ion exchange, solvent extraction and electrowinning systems are available for soluble ion removal, these methods are quite often ion specific and very expensive when treating large volumes of water. An inexpensive and ion non-specific accumulator system is the desirable alternative. The understanding and design of a functional bio-filter system for removal of uranium and other ions associated with uranium mining operations would alleviate discharge problems in the Grants uranium district (the producer of 40% of the U.S. uranium). Such a system would be applicable to the uranium-producing regions of Wyoming and Colorado. The bio-filter process may also be applicable to other industries, notably the

molybdenum extraction industry, where much water is used in the milling process and must be purified before it is discharged into rivers and streams.

OBJECTIVES

The objective of the study was to assess the role of biological agents in removal of inorganic trace contaminants from uranium mine wastewaters. In order to determine the effectiveness of a biological minewater treatment facility the following research plan was followed:

1. Analyses for selenium, molybdenum, uranium, and radium of the mine water, and various plant and microbial populations in the settling ponds on the Kerr-McGee Corp. property were conducted to ascertain which species accumulated soluble ions.
2. In the laboratory, the biological species active in accumulating selenium, molybdenum, uranium, and radium were identified and selected by standard biological techniques.
3. In the laboratory, the nutritional and growth characteristics of the bio-accumulators were examined, and conditions which resulted in maximum concentration of selenium, molybdenum, and uranium by the organisms were established. Conditions examined were temperature requirements, rate of water flow, amounts of phosphorus, nitrogen and trace elements required. The fate of accumulator organisms within the treatment system was determined. Questions asked were 1) will the concentrated elements be released

back into the system as soluble ions, or 2) will the dead organisms with their accumulated elements deposit at the bottom of the settling pond?

4. A bench-scale model was constructed to simulate a system for removal of inorganic ions from mine wastes. From this model the retention time of water for maximum ion removal by the bio-filter agent was estimated.

FIELD SITE

A wastewater treatment system for mine water pumped from two uranium mines was selected for study. The system is used by the Kerr-McGee Corporation for their sections 35 and 36 mines in the Ambrosia Lake district near Grants, New Mexico. The treatment system consists of a series of settling ponds for primary water treatment, an ion-exchange plant for uranium removal, addition of barium chloride for radium removal, and a series of algae ponds for final settling and pollutant removal (Figure 1). This system treats about 4.3×10^6 gallons of water each day with each mine contributing one-half of the total volume. During the course of the study, the treatment system was subject to temporary alterations. Ponds were by-passed and dredged and later returned to the system. These alterations are reflected in the data presentation in the subsequent sections.

REPORT PRESENTATION

The technical report is divided into four sections: the physico-chemical aspects of the water treatment system; the role of algae in pollutant removal from the water; the bacteriology of

Section 35 Mine

Section 36 Mine

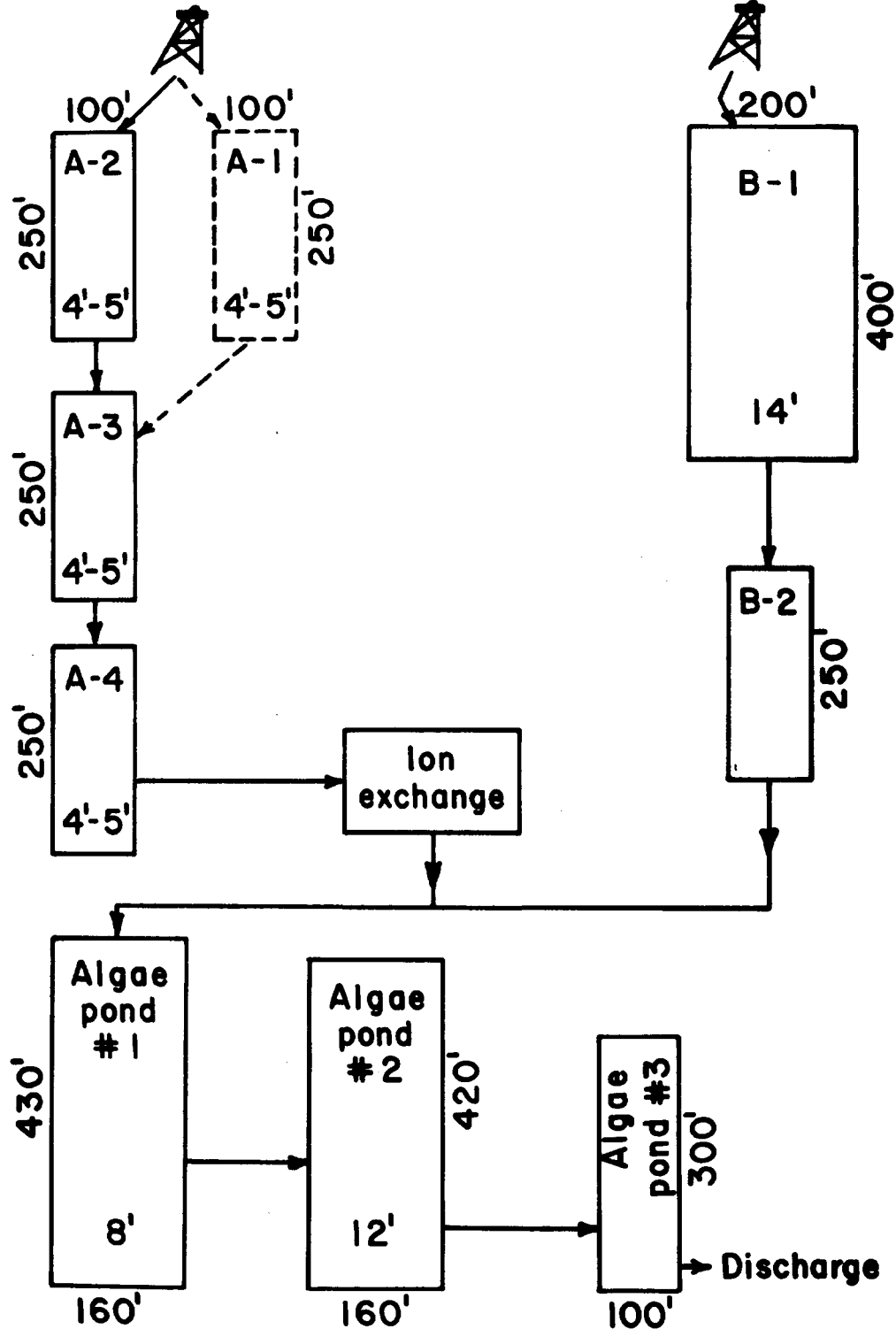

Figure 1—Schematic of settling ponds for Kerr McGee Corp. Sections 35 and 36 waste waters

the mine water treatment system; and a summary of the results of the project. The report is completed with the bibliography and an appendix listing the publications and presentations resulting from the research to date.

WATER AND SEDIMENT CHEMISTRY OF A URANIUM MINE WASTEWATER TREATMENT FACILITY

As part of the overall study to examine the role of biological and chemical agents in the removal of selected inorganic contaminants from uranium wastewaters, a series of chemical analyses were conducted. Over a four-year period, water and sediment samples were collected from the uranium mine water treatment facility constructed for removal of trace contaminants from waters of Sections 35 and 36 mines operated by the Kerr-McGee Corporation at Ambrosia Lake near Grants, New Mexico, U.S.A. The samples were collected to ascertain the partitioning of selected inorganic contaminants in the system and to determine the success of physical-chemical and biological processes in removal of these selected contaminants. Several water chemistry parameters were routinely examined, and the levels of several elements of nutritional need were examined for their presence in the mine waters.

MATERIALS AND METHODS

Sample Collection

Water samples for analyses of selenium, molybdenum and uranium were collected in 1-l acid-washed, polypropylene bottles containing 15 ml of concentrated nitric acid. Water samples for nitrate were collected in 500 ml glass bottles; these samples were refrigerated immediately following collection. Waters for phosphate analysis were collected in 500 ml glass bottles, washed thoroughly with phosphate-free detergent. Before analysis, all

samples were filtered through 0.45 μm Millipore filters.

Sediment samples were collected near the banks of the impoundments. These grab samples were obtained using a shovel or hoe. The samples were placed in plastic bags for transport to the laboratory.

Core-samples from the impoundment basins were obtained by driving PVC pipe, 38 cm in length and 3.8 cm ID, into the sediments. Caps were screwed onto the ends of the pipes for transport of the core to the laboratory.

Collection of Field Data

Eh and pH were measured in the field using an Orion Ion Analyzer Model 407A or Analog A/F Portable pH Meter Model 399. Some water samples were measured in the laboratory for pH; these measurements were made immediately upon return of the sample to the laboratory using waters collected for nitrate analysis. The instrument used was a Copenhagen Radiometer pHM82 standard pH meter.

Conductivity of water was measured either in the laboratory with samples collected for nitrate analysis or in the field using a YSI Model 33 S-C-T Meter. Temperature was measured with a mercury thermometer or a YSI Model 33 S-C-T Meter. A YSI Model 57 DO Meter was used to measure dissolved oxygen at the field site.

Analyses

Solids Processing:

Core samples were removed from PVC pipe by pushing the core at one end with a solid object. The sample was obtained as a solid core which was characterized according to color, and from which individual sections were taken for analyses. The core

sections and sediment samples were dried overnight at 105°C. Dry weights were calculated. Before digestion of the dried solids, the samples were pulverized using a mortar and pestle. A representative sample was obtained by coning and quartering the sample (Testing Sieves, 1972).

Total suspended solids in liquid samples were determined according to Standard Methods (1976). For analysis of suspended solids a known volume of acidified sample was passed through a 0.45 µm Millipore filter; the weight of the suspended matter was determined from the total suspended solids assay. The total suspended matter and the membrane were digested (EPA, 1979).

Sediments and core sections were acid decomposed (Brandvold, 1974). Total sulfur in core samples and sediments was determined by the fusion method (Scott, 1939).

Analytical Procedures for Aqueous Samples

Uranium was analyzed by the trioctylphosphine oxide method (Yoe, et al., 1953), and molybdenum was assayed by a modification (Meglen and Glaze, 1973) of the colorimetric thiocyanate-stannous chloride method (Sandell, 1950). A Bausch & Lomb Spectronic 20 was used for colorimetric assay. Selenium was determined fluorometrically (Chan, 1976); fluorescence was read on a Turner Model 110 fluorometer.

Sulfate was determined by the gravimetric method with drying of residue using Gooch crucibles and #934AH glass fiber filters (Standard Methods, 1976).

Copper, total iron, and vanadium were analyzed using a Perkin Elmer Model 303 atomic absorption spectrophotometer. Nitrate was

assayed by the ultraviolet spectrophotometric method (Standard Methods, 1976) using the Beckman DB Spectrophotometer.

Phosphate was analyzed by the stannous chloride method, measuring color development with the Bausch & Lomb Spectronic 20.

Radium (^{226}Ra) concentration was determined by measuring the equilibrium amount of radon (^{222}Rn) emanating from the sample. The radon was removed by bubbling dry nitrogen through the sample. The ^{222}Rn was collected in a charcoal trap at dry-ice temperature, and the collected ^{222}Rn was transferred to a Lucas chamber for alpha counting.

RESULTS AND DISCUSSION

Mine Waters

Temperature:

Table I presents the temperatures of the mine waters measured during sampling trips. The temperatures of the waters coming from the mines were nearly constant, varying only 1-2 degrees. Section 36 water was slightly warmer than Section 35 water. In winter months the water temperatures decreased during passage through the treatment facility. The lowest temperature recorded was 10°C during January 1979. During one summer sampling (September 1980) the water temperature increased to 26.5°C.

pH, Eh, and Dissolved Oxygen:

pH values measured for collected samples are tabulated in Table II. Values ranged from 6.35 to 8.33. These variations were probably due to changes in the mineralogy of ore and gangue mined. Little variation was noted as the mine waters migrated through the treatment impoundments, and no variation in pH was detected

TABLE I. Temperatures of waters collected over a 4-year period from a uranium mine water treatment facility near Grants, New Mexico

Sample Location	Date of Collection								
	10/19/78	1/15/78	1/19/79	3/6/79	6/29/79	1/24/80	4/29/80	9/17/80	3/31/80
Temperatures (°C)									
Effluent - Sec. 35	ND	20.0	19.5	21.0	22.0	22.0	21.0	22.5	22.0
Pond A-1 Effluent - Sec. 35	ND	ND	ND	ND	ND	ND	ND	ND	22.0
Pond A-2 Effluent - Sec. 35	ND	19.0	ND	17.0	23.0	ND	20.0	20.0	21.0
Pond A-3 Effluent - Sec. 35	ND	17.0	ND	16.5	23.5	ND	19.0	21.0	19.0
Pond A-4 Effluent - Sec. 35	21.0	16.0	16.0	16.5	20.0	19.5	ND	24.0	18.5
Effluent - Sec. 36	ND	23.0	22.0	23.0	24.0	23.0	ND	24.5	24.5
Pond B-1 Effluent - Sec. 36	ND	16.0	14.0	17.0	24.0	Dry	Dry	Dry	18.5
Pond B-2 Effluent - Sec. 36	20.0	15.0	13.0	15.0	21.0	22.0	ND	24.0	18.5
Confluence - Sec. 35 and 36	ND	15.0	14.0	15.5	21.0	21.1	ND	23.5	16.0
Algae Pond #1 Effluent	19.5	ND	11.5	14.0	20.0	20.5	ND	23.5	Dry
Algae Pond #2 Effluent	ND	12.0	10.5	12.0	20.0	20.6	ND	26.5	ND
Algae Pond #3 Effluent	ND	ND	10.0	12.0	20.0	20.5	ND	23.0	17.0

ND = Not Determined

TABLE II. pH of waters collected over a 3-year period from a uranium mine water treatment facility near Grants, New Mexico

Sample Location	Date of Collection							
	1/19/79	3/6/79	6/29/79	9/25/79	1/24/80	4/29/80	9/17/80	3/31/81
	pH							
Effluent - Sec. 35	7.00	7.51	6.35	7.85	8.14	ND	8.02	8.03
Pond A-1 Effluent - Sec. 35	ND	ND	ND	ND	ND	ND	ND	8.33
Pond A-2 Effluent - Sec. 35	7.20	7.23	6.63	8.10	8.15	8.08	7.66	7.98
Pond A-3 Effluent - Sec. 35	7.0	7.41	6.90	8.05	8.10	8.00	8.00	7.56
Pond A-4 Effluent - Sec. 35	7.10	7.30	7.10	7.95	8.12	8.01	7.88	7.88
Effluent - Sec. 36	7.00	7.30	6.85	8.15	8.21	8.07	7.88	7.90
Pond B-1 Effluent - Sec. 36	7.10	7.52	6.94	Dry	Dry	Dry	Dry	7.95
Pond B-2 Effluent - Sec. 36	7.20	7.80	7.05	8.05	8.24	8.20	8.08	8.15
Confluence - Sec. 35 and 36	7.20	7.63	7.00	8.00	8.13	8.04	8.00	7.95
Algae Pond #1 Effluent	7.60	7.85	7.10	7.90	7.57	8.01	8.02	Dry
Algae Pond #2 Effluent	7.00	7.89	7.10	7.95	8.15	8.06	7.99	7.90
Algae Pond #3 Effluent	7.20	8.02	7.25	8.10	8.22	8.05	8.10	7.90

ND - Not Determined

with season.

Eh values (Table III) for the mines waters showed the system to be oxidizing. The values were generally above +500 mv. Data for March 31, 1981, were low; however, this was probably due to a malfunctioning Eh electrode.

Dissolved oxygen values (Table IV) indicated that the waters were well oxygenated. The amount of oxygen in the waters increased with passage of the water through the impoundment system. This probably resulted from photosynthesis by algae in the ponds and the shallow depths of the ponds. Waters issuing from algae pond #3 were nearly saturated with oxygen.

Conductivity:

The conductivity values of water samples collected from the mine water treatment facility are recorded in Table V. These values reflect the total concentration of ionized substances dissolved in the water. The conductivity of most potable waters ranges from 50 to 1500 μ mhos/cm; the conductivity values recorded for the mine waters were near the upper range of potable waters. As can be noted from the Section 35 and 36 influent values and the algae pond #3 effluent values, there was no decrease in conductivity. This suggests that there was no decrease in the concentration of dissolved species from the initial influent to the final effluent.

Sulfate and Radium:

Sulfate concentrations measured in liquid samples throughout the mine water treatment facility are tabulated in Table VI. Despite the addition, just before the confluence of Sections 35 and 36 waters, of barium chloride, no decrease in sulfate concentration

TABLE III. Eh of waters collected over a 3-year period
from a uranium mine water treatment facility near Grants, New Mexico

Sample Location	Date of Collection							
	1/19/79	3/6/79	6/29/79	9/25/79	1/24/80	4/29/80	9/17/80	3/31/81
Effluent - Sec. 35	+694	+514	+544	+554	+564	+514	+594	+467
Pond A-1 Effluent - Sec. 35	ND	ND	ND	ND	ND	ND	ND	+447
Pond A-2 Effluent - Sec. 35	+594	+494	+584	+564	+544	+554	+594	+467
Pond A-3 Effluent - Sec. 35	+594	+534	+514	+544	+559	+529	+594	+467
Pond A-4 Effluent - Sec. 35	+594	+534	+564	+544	+574	+509	+574	+467
Effluent - Sec. 36	+604	+584	+564	+524	+544	+544	+574	+467
Pond B-1 Effluent - Sec. 36	+589	+504	+584	Dry	Dry	Dry	Dry	+465
Pond B-2 Effluent - Sec. 36	+599	+584	+604	+534	+564	+524	+564	+457
Confluence Sec. 35 and 36	+589	+534	+604	+524	+569	+534	+569	+472
Algae Pond #1 Effluent	+614	+564	+584	+544	+564	+524	+564	Dry
Algae Pond #2 Effluent	+549	+544	+614	+544	+564	+554	+564	+447
Algae Pond #3 Effluent	+569	+564	+579	+524	+584	+514	+554	+467

ND - Not Determined

TABLE IV. Dissolved oxygen in waters collected over a one-year period from a uranium mine water treatment facility near Grants, New Mexico

Sample Location	Date of Collection			
	9/25/79	1/24/80	4/29/80	9/17/80
Dissolved Oxygen (mg/l)				
Effluent - Sec. 35	6.3	6.8	6.7	6.0
Pond A-1 Effluent - Sec. 35	ND	ND	ND	6.7
Pond A-2 Effluent - Sec. 35	ND	ND	6.7	5.5
Pond A-3 Effluent - Sec. 35	6.3	ND	6.7	5.3
Pond A-4 Effluent - Sec. 35	6.5	5.4	7.0	5.1
Effluent - Sec. 36	6.0	7.2	6.3	6.0
Pond B-1 Effluent - Sec. 36	Dry	Dry	Dry	Dry
Pond B-2 Effluent - Sec. 36	7.8	7.3	7.2	6.1
Confluence - Sec. 35 and 36	6.8	6.9	6.9	5.9
Algae Pond #1 - Effluent	5.0	7.0	7.0	5.6
Algae Pond #2 - Effluent	8.4	7.3	8.6	6.2
Algae Pond #3 - Effluent	9.7	9.4	9.3	8.4

ND = Not Determined

TABLE V. Conductivity of waters collected over a 3-year period from a uranium mine water treatment facility near Grants, New Mexico

Sample Location	Date of Collection						
	1/19/79	3/6/79	6/29/79	9/25/79	4/29/80	9/17/80	3/31/81
Conductivity (μ mhos/cm)							
Effluent - Sec. 35	1650	1050	1300	1200	1200	1500	1010
Pond A-1 Effluent - Sec. 35	ND	ND	ND	ND	ND	ND	1070
Pond A-2 Effluent - Sec. 35	1690	1250	1250	1150	1200	1500	1020
Pond A-3 Effluent - Sec. 35	1680	1270	1300	1150	1200	1590	1070
Pond A-4 Effluent - Sec. 35	1700	1310	1250	1150	1050	1450	1060
Effluent - Sec. 36	1580	1300	1200	1200	1200	900	1000
Pond B-1 Effluent - Sec. 36	1550	1300	1200	Dry	Dry	Dry	1000
Pond B-2 Effluent - Sec. 36	1600	1280	1150	1200	1200	1640	1030
Confluence - Sec. 35 and 36	1580	1230	1250	1150	1200	1640	1040
Algae Pond #1 Effluent	1690	1290	1300	1150	1200	1830	Dry
Algae Pond #2 Effluent	1690	1280	1300	1150	1200	1550	1030
Algae Pond #3 Effluent	1660	1300	1350	1200	1050	1590	1060

TABLE VI. Sulfate concentration in waters collected over a 3-year period
from a uranium mine water treatment facility near Grants, New Mexico

Sample Location	Date of Collection								
	10/19/78	11/15/78	1/19/79	3/6/79	6/26/79	9/25/79	1/24/80	4/24/80	9/17/80
	Sulfate (mg/l)								
Effluent - Sec. 35	661.7	753.9	755.5	631.2	757.2	704.7	720.1	691.3	658.4
Pond A-1 Effluent - Sec. 35	ND	ND	ND	ND	ND	ND	ND	ND	ND
Pond A-2 Effluent - Sec. 35	ND	767.9	783.5	650.2	703.7	711.9	724.2	679.0	699.6
Pond A-3 Effluent - Sec. 35	ND	799.1	743.2	700.4	621.4	683.1	695.4	934.1	337.4
Pond A-4 Effluent - Sec. 35	653.5	753.9	714.4	613.1	724.2	674.9	666.6	637.8	609.0
Effluent - Sec. 36	454.3	736.6	683.9	646.1	679.0	711.9	761.3	576.1	584.3
Pond B-1 Effluent - Sec. 36	ND	741.5	732.5	670.8	744.8	Dry	Dry	Dry	Dry
Pond B-2 Effluent - Sec. 36	724.2	750.6	755.5	655.1	637.8	584.3	707.8	674.9	329.2
Confluence Sec. 35 and 36	615.6	759.6	751.4	669.9	641.9	695.4	707.8	646.1	748.9
Algae Pond #1 Effluent	686.4	765.4	762.9	669.1	662.5	711.9	687.2	683.1	683.1
Algae Pond #2 Effluent	697.9	766.2	735.8	620.5	670.7	695.4	728.4	691.3	732.5
Algae Pond #3 Effluent	742.3	771.2	757.2	675.7	650.2	736.6	687.2	650.2	617.3

ND - Not Determined

in the waters of algae ponds #1, #2 and #3 was noted. However, only 8 mg of barium chloride was added per liter of water. This amount of barium would only react with 3.7 mg sulfate per liter. This small decrease in sulfate concentration would not be detectable in the sulfate analyses shown in Table VI.

Barium chloride was added to co-precipitate radium. Few radium analyses were completed; however, the results of these are reported in Table VII. These data showed that the radium concentration in the mine water from Section 36 was high (90 ± 20 pC; ℓ^{-1}). No radium assays were made on Section 35 waters; however, by examining the Sections 35 and 36 confluence for radium concentration (2.3 ± 0.5 pC; ℓ^{-1}), it was evident that much of the radium was removed prior to barium chloride treatment of the mine waters. Although no analyses were conducted on the amount of radium associated with particulate matter, it is suggested that the decrease in radium concentrations of the waters may be due to the adsorption of radium to suspended matter.

Uranium:

Table VIII summarizes the uranium analyses of the waters of the mine water treatment facility. The concentrations of uranium in the effluents of Sections 35 and 36 were variable with the Section 35 effluent generally having higher uranium values than the Section 36 effluent. Uranium values in solution decreased somewhat as the waters passed through the initial settling ponds (A1-4 and B1 and 2); however, B-1 and B-2 were more effective at removal of the uranium than the A series of ponds.

The uranium values noted for the confluence of Sections 35

TABLE VII. Radium concentrations in selected water samples collected October 19, 1978, from a uranium mine water treatment facility

Sample	$^{226}\text{Radium}$ (pCi/l)
Effluent - Sec. 36	90 ±20
Confluence - Sec. 35 and 36	2.3± 0.5
Algae Pond #1 - Effluent	1.5± 0.4
Algae Pond #2 - Effluent	2.9± 7.0
Algae Pond #3 - Effluent	7.0± 3.0

TABLE VIII. Uranium concentrations in waters and sediments collected over a 3-year period from a uranium mine water treatment facility near Grants, New Mexico

Sample Location	Date of Collection									
	10/19/78	11/15/78	1/19/79	3/6/79	6/29/79	9/25/79	1/24/80	4/29/80	9/17/80	3/31/81
	Water - Uranium (mg/l)									
Effluent - Sec. 35	11.10	7.29	4.20	4.80	4.88	7.38	3.60	1.00	4.16	4.10
Pond A-1 Effluent - Sec. 35	ND	ND	ND	ND	ND	ND	ND	ND	ND	4.30
Pond A-2 Effluent - Sec. 35	ND	6.25	5.80	5.90	6.98	5.75	5.20	7.94	5.80	3.36
Pond A-3 Effluent - Sec. 35	ND	5.70	5.40	5.40	6.33	6.97	6.00	4.66	3.68	4.26
Pond A-4 Effluent - Sec. 35	8.60	5.55	6.80	4.60	4.72	5.80	4.10	3.87	4.94	3.36
Effluent - Sec. 36	1.44	1.48	11.60	7.24	3.59	0.82	1.40	2.88	0.98	1.68
Pond B-1 Effluent - Sec. 36	ND	1.00	2.40	1.20	0.51	Dry	Dry	Dry	Dry	0.86
Pond B-2 Effluent - Sec. 36	0.70	0.72	1.40	0.80	0.63	2.84	0.58	3.92	1.16	0.87
Confluence Sec. 35 and 36	2.05	1.35	2.00	1.00	0.51	0.96	0.64	0.64	1.09	0.72
Algae Pond #1 Effluent	7.00(?)	0.90	1.30	0.80	0.50	0.92	2.80(?)	2.88(?)	1.18	Dry
Algae Pond #2 Effluent	2.65	1.38	1.70	0.50	0.67	0.55	0.90	0.60	0.77	0.84
Algae Pond #3 Effluent	8.00(?)	0.96	1.30	0.60	0.53	0.96	0.36	ND	0.80	0.75
	Solids - Uranium (%)									
Suspended Particulates:										
Effluent Sec. 35	ND	ND	ND	ND	5.5x10 ⁻¹	1.5x10 ⁰	6.3x10 ⁻¹	ND	ND	ND
Effluent Sec. 36	ND	ND	ND	ND	7.0x10 ⁻²	2.8x10 ¹	3.6x10 ⁻¹	ND	ND	ND
Algae Pond #3 Effluent	ND	ND	ND	ND	8.3x10 ⁻¹	8.4x10 ⁰	3.9x10 ⁰	ND	ND	ND
Sediments:										
Pond A-1 - Sec. 35	ND	8.8x10 ⁻²	1.3x10 ⁻¹	9.3x10 ⁻²	8.6x10 ⁻²	8.2x10 ⁻²	7.2x10 ⁻²	ND	3.6x10 ⁻²	2.8x10 ⁻²
Pond A-2 - Sec. 35	ND	6.5x10 ⁻²	1.0x10 ⁻¹	6.3x10 ⁻²	1.1x10 ⁻²	6.7x10 ⁻²	1.2x10 ⁻³	ND	3.9x10 ⁻²	2.2x10 ⁻²
Pond A-3 - Sec. 35	ND	1.9x10 ⁻¹	1.0x10 ⁻¹	1.7x10 ⁻¹	1.8x10 ⁻²	7.4x10 ⁻²	1.2x10 ⁻³	2.1x10 ⁻¹	2.3x10 ⁻¹	1.0x10 ⁻¹
Pond A-4 - Sec. 35	ND	7.8x10 ⁻²	1.2x10 ⁻¹	1.2x10 ⁻²	ND	2.0x10 ⁻¹	3.0x10 ⁻³	2.3x10 ⁻¹	2.7x10 ⁻¹	ND
Pond B-1 - Sec. 36	ND	4.5x10 ⁻²	0	5.5x10 ⁻²	2.1x10 ⁻¹	3.3x10 ⁻¹	9.2x10 ⁻³	6.0x10 ⁻¹	6.6x10 ⁻¹	3.2x10 ⁻²
Pond B-2 - Sec. 36	ND	4.3x10 ⁻²	1.0x10 ⁻¹	1.1x10 ⁻²	5.1x10 ⁻²	1.5x10 ⁻¹	4.4x10 ⁻³	ND	4.0x10 ⁻¹	7.1x10 ⁻²
Algae Pond #1	ND	5.4x10 ⁻²	1.1x10 ⁻¹	1.5x10 ⁻¹	2.4x10 ⁻¹	1.9x10 ⁻¹	1.6x10 ⁻³	2.3x10 ⁻¹	2.2x10 ⁻¹	2.9x10 ⁻¹
Algae Pond #2	ND	5.9x10 ⁻²	5.7x10 ⁻³	1.0x10 ⁻¹	1.3x10 ⁻¹	1.5x10 ⁻¹	7.8x10 ⁻²	1.3x10 ⁻¹	6.7x10 ⁻²	1.4x10 ⁻²
Algae Pond #3	ND	8.1x10 ⁻²	1.4x10 ⁻¹	1.0x10 ⁻¹	7.6x10 ⁻²	1.4x10 ⁻¹	1.2x10 ⁻¹	3.8x10 ⁻²	9.2x10 ⁻²	1.4x10 ⁻¹

ND - Not Determined

(?) - Data inconsistent, possible analytical error

and 36 were low due to the use of ion exchange resins for recovery of the uranium. During the initial part of the study only Section 35 waters were passed through the resin columns, but during the latter phase of the study both mine effluents were treated. The resins removed more than 50% of the soluble uranium from the mine waters. Somewhat more soluble uranium was removed from the waters as they moved through the three algae ponds. However, there did not appear to be any correlation between the effectiveness of the algae ponds in removal of soluble uranium and the season. The effluent from algae pond #3 contained less than 1 mg uranium per liter as determined by the 10 selected samplings.

Although no speciation studies were made of the soluble uranium, it is anticipated, based on the water chemistry of the mine waters, that the uranium would be in the form of negatively charged carbonate complexes (Hostetler and Garrels, 1962; Garrels and Christ, 1965). These species would not be expected to extensively adsorb to negatively charged algae or clay particles.

Molybdenum:

The levels of soluble molybdenum in waters of the mine treatment facility are shown in Table IX. The soluble molybdenum concentrations in the discharge of Section 35 were higher than in the Section 36 discharge. Neither the A nor B series of settling impoundments were effective in removal of the soluble molybdenum. The values recorded in Table IX for the confluence of Sections 35 and 36 waters represent the average soluble molybdenum concentration for the two mines. The three algae ponds were also

TABLE IX. Molybdenum concentrations in waters and sediments collected over a 4-year period from a uranium mine water treatment facility near Grants, New Mexico

Sample Location	Date of Collection									
	10/19/78	11/15/78	1/19/79	3/6/79	6/29/79	9/25/79	1/24/80	4/24/80	9/17/80	3/31/81
	Water - Molybdenum ($\mu\text{g}/\ell$)									
Effluent - Sec. 35	2320	1838	2650	2255	1918	981	1812	1920	1912	ND
Pond A-1 Effluent - Sec. 35	ND	ND	ND	ND	ND	ND	ND	ND	ND	724
Pond A-2 Effluent - Sec. 35	ND	2166	2515	2225	1657	911	1902	1944	1982	1665
Pond A-3 Effluent - Sec. 35	ND	2221	2185	2375	1797	917	1844	1739	1808	1665
Pond A-4 Effluent - Sec. 35	2230	2248	2300	2065	1898	981	1889	1708	1808	ND
Effluent - Sec. 36	18	20	25	167	3	7	31	65	570	24
Pond B-1 Effluent - Sec. 36	ND	45	38	70	26	Dry	Dry	Dry	Dry	32
Pond B-2 Effluent - Sec. 36	21	63	67	65	37	59	40	60	750	78
Confluence Sec. 35 and 36	910	1037	1260	1095	566	4507(?)	794	743	988	730
Algae Pond #1 Effluent	1245	955	1340	1225	788	562	1244	793	793	Dry
Algae Pond #2 Effluent	1120	676	1305	1370	870	476	878	809	773	ND
Algae Pond #3 Effluent	1190	117	800	1095	1022	428	873	910	768	726
	Solids - Molybdenum (%)									
Suspended Particulates:										
Effluent Sec. 35	ND	ND	ND	ND	1.7×10^{-2}	5.5×10^{-2}	2.7×10^{-2}	2.9×10^{-1}	ND	4.0×10^{-2}
Effluent Sec. 36	ND	ND	ND	ND	6.0×10^{-5}	2.0×10^{-1}	6.0×10^{-3}	4.1×10^{-3}	ND	2.5×10^{-3}
Algae Pond #3 Effluent	ND	ND	ND	ND	1.2×10^{-2}	ND	6.5×10^{-2}	2.9×10^{-1}	ND	8.3×10^{-2}
Sediments:										
Pond A-1 - Sec. 35	ND	1.9×10^{-2}	1.3×10^{-2}	1.4×10^{-2}	5.8×10^{-3}	6.5×10^{-3}	4.7×10^{-3}	ND	5.5×10^{-5}	1.2×10^{-3}
Pond A-2 - Sec. 35	ND	5.0×10^{-3}	8.0×10^{-3}	4.3×10^{-3}	7.4×10^{-3}	3.1×10^{-3}	7.6×10^{-3}	ND	ND	2.1×10^{-3}
Pond A-3 - Sec. 35	ND	3.4×10^{-2}	2.0×10^{-2}	3.1×10^{-2}	2.5×10^{-2}	1.8×10^{-2}	2.6×10^{-2}	1.3×10^{-2}	3.5×10^{-4}	3.8×10^{-3}
Pond A-4 - Sec. 35	ND	1.6×10^{-2}	8.0×10^{-3}	2.4×10^{-2}	8.0×10^{-4}	1.8×10^{-2}	1.6×10^{-3}	1.5×10^{-2}	1.5×10^{-5}	6.3×10^{-3}
Pond B-1 - Sec. 36	ND	7.0×10^{-4}	0	8.5×10^{-4}	6.5×10^{-3}	1.6×10^{-3}	2.9×10^{-3}	1.7×10^{-2}	6.7×10^{-5}	9.0×10^{-4}
Pond B-2 - Sec. 36	ND	6.0×10^{-4}	1.0×10^{-3}	1.4×10^{-2}	2.5×10^{-3}	2.1×10^{-3}	3.2×10^{-3}	2.1×10^{-2}	8.5×10^{-5}	2.0×10^{-4}
Algae Pond #1	ND	7.0×10^{-3}	1.0×10^{-2}	4.3×10^{-2}	2.9×10^{-2}	4.5×10^{-2}	2.9×10^{-2}	2.1×10^{-2}	2.3×10^{-4}	2.9×10^{-3}
Algae Pond #2	ND	9.0×10^{-3}	3.0×10^{-4}	7.6×10^{-3}	1.3×10^{-2}	1.3×10^{-2}	1.6×10^{-2}	8.3×10^{-3}	1.2×10^{-5}	4.2×10^{-4}
Algae Pond #3	ND	1.6×10^{-2}	4.7×10^{-2}	3.2×10^{-2}	3.6×10^{-2}	5.4×10^{-2}	3.8×10^{-2}	4.7×10^{-2}	2.4×10^{-3}	2.9×10^{-3}
Control										

ND - Not Determined

(?) - Data inconsistent, possible analytical error

ineffective in removal of soluble molybdenum, and the effluent from algae pond #3 contained soluble molybdenum in concentrations of approximately 0.5-1.0 mg ℓ^{-1} .

No speciation of the soluble molybdenum was determined; however, based on the water chemistry, the molybdenum would probably exist as MoO_4^{2-} (Kaback and Runnells, 1980). This negatively charged species would not be expected to adsorb effectively to negatively charged algae or particulates. This may explain its unaffected passage through the water treatment system.

Selenium:

The soluble selenium in the mine waters would probably be in the form of selenite or selenate; the latter would be formed at the higher pH levels of the water (Lakin, 1973; Measures and Burton, 1978; Trudinger et al., 1979). The concentrations of these species in the mine waters as they flowed through the treatment impoundments are tabulated in Table X. By passage of the water through the system approximately 50% of the soluble selenium was removed from the water. The algae pond #3 effluent selenium (soluble) values recorded during the sampling trips ranged from 5 to 131 mg ℓ^{-1} .

The mechanism of selenium removal from the waters is unclear; however, adsorption of the negatively charged selenite and selenate to negatively charged clays and ligands of organic matter probably does not account for its precipitation. At pH 6.3-6.7 selenium can be precipitated as basic ferric selenite (Lakin, 1973; Howard, 1971; Measures and Burton, 1978; Trudinger et al., 1979).

TABLE X. Selenium concentrations in waters and sediments collected over a 4-year period from a uranium mine water treatment facility near Grants, New Mexico

Sample Location	Date of Collection									
	10/19/78	11/15/78	1/19/79	3/6/79	6/29/79	9/25/79	1/24/80	4/24/80	9/17/80	3/31/81
	Water - Selenium ($\mu\text{g}/\ell$)									
Effluent - Sec. 35	41	24	48	43	16	21	14	16	22	18
Pond A-1 Effluent - Sec. 35	ND	ND	ND	ND	ND	ND	ND			21
Pond A-2 Effluent - Sec. 35	ND	24	15	22	12	20	14	13	20	18
Pond A-3 Effluent - Sec. 35	ND	25	28	23	12	190(?)	10	25	19	18
Pond A-4 Effluent - Sec. 35	18	25	31	23	12	20	14	26	19	18
Effluent - Sec. 36	55	38	78	67	5	2	10	13	19	5
Pond B-1 Effluent - Sec. 36	ND	44	51	3	2	Dry	Dry	Dry	Dry	5
Pond B-2 Effluent - Sec. 36	39	34	60	3	2	5	14	5	5	6
Confluence Sec. 35 and 36	35	12	125	8	6	10	4	10	10	13
Algae Pond #1 Effluent	18	14	173	8	7	10	10	9	12	Dry
Algae Pond #2 Effluent	19	16	9	7	10	10	48	8	19	5
Algae Pond #3 Effluent	19	13	131	12	7	11	5	8	12	5
	Solids - Selenium (%)									
Suspended Particulates										
Effluent Sec. 35	ND	ND	ND	ND	5.5×10^{-2}	7.1×10^{-2}	2.5×10^{-2}	1.6×10^{-6}	ND	ND
Effluent Sec. 36	ND	ND	ND	ND	4.9×10^{-3}	5.7×10^{-1}	2.7×10^{-2}	1.3×10^{-6}	ND	ND
Algae Pond #3 Effluent	ND	ND	ND	ND	ND	ND	trace	1.0×10^{-7}	ND	ND
Sediments:										
Pond A-1 - Sec. 35	ND	9.0×10^{-3}	1.8×10^{-2}	2.3×10^{-2}	3.9×10^{-3}	1.6×10^{-2}	2.5×10^{-3}	1.4×10^{-3}	1.6×10^{-2}	ND
Pond A-2 - Sec. 35	ND	3.7×10^{-4}	1.8×10^{-2}	1.1×10^{-2}	3.0×10^{-3}	9.3×10^{-3}	7.7×10^{-3}	5.3×10^{-3}	5.0×10^{-4}	ND
Pond A-3 - Sec. 35	ND	1.6×10^{-2}	1.2×10^{-2}	1.2×10^{-2}	2.3×10^{-3}	6.5×10^{-3}	5.6×10^{-3}	5.9×10^{-3}	4.1×10^{-3}	ND
Pond A-4 - Sec. 35	ND	4.1×10^{-3}	6.0×10^{-3}	1.2×10^{-2}	9.0×10^{-5}	8.8×10^{-3}	7.5×10^{-3}	1.1×10^{-2}	2.3×10^{-3}	ND
Pond B-1 - Sec. 36	ND	5.0×10^{-4}	7.0×10^{-4}	2.0×10^{-3}	1.4×10^{-3}	8.8×10^{-3}	1.4×10^{-2}	1.1×10^{-3}	3.0×10^{-3}	ND
Pond B-2 - Sec. 36	ND	8.0×10^{-4}	2.5×10^{-3}	5.7×10^{-3}	3.0×10^{-4}	3.7×10^{-3}	7.5×10^{-3}	5.6×10^{-3}	2.4×10^{-4}	ND
Algae Pond #1	ND	1.6×10^{-3}	7.0×10^{-3}	1.3×10^{-2}	2.9×10^{-3}	1.0×10^{-2}	5.0×10^{-3}	3.2×10^{-3}	8.7×10^{-4}	ND
Algae Pond #2	ND	2.0×10^{-3}	1.1×10^{-3}	4.7×10^{-3}	1.4×10^{-3}	4.5×10^{-3}	1.2×10^{-3}	4.0×10^{-3}	2.2×10^{-3}	ND
Algae Pond #3	ND	8.0×10^{-3}	8.0×10^{-3}	1.4×10^{-2}	3.0×10^{-3}	1.1×10^{-2}	3.2×10^{-3}	5.7×10^{-5}	1.7×10^{-3}	ND

ND - Not Determined

(?) - Data inconsistent, possible analytical error

Copper, Iron and Vanadium:

The concentrations of copper, iron and vanadium in the mine waters are shown in Table XI. Copper concentrations were very low and vanadium in solution was less than $3.7 \text{ mg } \ell^{-1}$. Copper and vanadium would be expected to form the species Cu^{2+} , CuSO_4 and $\text{VO}_2(\text{OH})_3^{2-}$ (Mason, 1966). The iron solution would be oxidized, and the ferric iron would be expected to form insoluble $\text{Fe}(\text{OH})_3$ (Mason, 1966) or participate in reactions such as the formation of insoluble basic ferric selenite (Lakin, 1973). The high concentration of soluble iron in the waters noted during the June 1979 collection was unusual; freshwater iron concentrations are generally about $3\text{-}4 \text{ } \mu\text{g } \ell^{-1}$ (Trudinger and Swaine, 1979).

Nitrate and Phosphate:

Nitrate and phosphate are both important in the biological productivity of waters. Nitrate levels were generally higher in Section 35 water than in Section 36 water, and nitrate levels in the algae ponds were less than $1 \text{ mg } \ell^{-1}$ (Table XII). Although these levels are probably sufficient to sustain algae productivity at an oligo-mesotrophic level (Wetzel, 1975), algae productivity of a eutrophic level would not be likely with this level of nitrogen. Although nitrate may be limiting in the algae impoundments of the treatment system, some of the species present were blue-green algae and would possess the ability to fix atmospheric nitrogen. Ammonia was not analyzed in the waters since its presence in highly oxygenated waters would be low. Any ammonia present would be sorbed to the particulate matter in solution and probably would not be available for algae use (Wetzel, 1975).

TABLE XI. Copper, iron and vanadium concentrations in waters and sediments collected over a one-year period from a uranium mine water treatment facility near Grants, New Mexico

Sample Location	Date of Collection								
	6/29/79			9/25/79			1/24/80		
	Cu (mg/l)	Fe (mg/l)	V (mg/l)	Cu (mg/l)	Fe (mg/l)	V (mg/l)	Cu (mg/l)	Fe (mg/l)	V (mg/l)
Water:									
Effluent - Sec. 35	0.03	13.8	0	Trace	3.7	1.3	0	1.5	Trace
Effluent - Sec. 36	0	17.9	3.7	Trace	ND	2.5	0	2.9	Trace
Effluent - Algae Pond #3	0	0	0	Trace	ND	0	0	0.3	0
	Cu (%)	Fe (%)	V (%)	Cu (%)	Fe (%)	V (%)	Cu (%)	Fe (%)	V (%)
Sediments:									
Pond B-1 - Sec. 36	1.2×10^{-2}	1.4×10^0	2.7×10^{-1}	2.9×10^{-3}	2.4×10^0	3.1×10^{-3}	2.6×10^{-3}	3.4×10^0	5.8×10^{-1}
Algae Pond #1	2.4×10^{-2}	1.8×10^0	2.8×10^{-1}	2.9×10^{-3}	6.2×10^0		ND	ND	ND

ND - Not Determined

TABLE XII. Nitrate concentration in waters collected over a 2-year period from a uranium mine water treatment facility near Grants, New Mexico

Sample Location	Date of Collection						
	1/19/79	3/6/79	6/ /79	9/25/79	1/24/80	4/24/80	9/17/80
	Nitrate (mg/l)						
Effluent Sec. 35	ND	1.87	0.81	1.33	0.60	0.90	1.04
Pond A-1 Effluent - Sec. 35	ND	ND	ND	ND	ND	ND	ND
Pond A-2 Effluent - Sec. 35	1.74	1.41	1.09	1.33	0.57	0.54	1.34
Pond A-3 Effluent - Sec. 35	1.13	1.44	1.00	1.25	0.63	0.53	0.98
Pond A-4 Effluent - Sec. 35	1.10	1.25	1.73	1.25	0.59	0.52	1.02
Effluent - Sec. 36	1.91	0.36	0.42	0.46	0.22	0.25	0.34
Pond B-1 Effluent - Sec. 36	2.60	0.21	0.44	Dry	Dry	Dry	Dry
Pond B-2 Effluent - Sec. 36	1.61	0.23	0.13	0.37	0.21	0.29	0.42
Confluence Sec. 35 and 36	0.73	0.48	0.29	0.42	0.37	0.32	0.70
Algae Pond #1 Effluent	0.78	0.55	0.34	0.64	0.38	0.30	0.60
Algae Pond #2 Effluent	0.64	0.47	0.34	0.56	0.34	0.30	0.42
Algae Pond #3 Effluent	0.94	0.48	0.21	0.54	0.35	0.26	0.48

ND - Not Determined

Phosphorus is more directly related to lake productivity than nitrogen (Wetzel, 1975). The levels of phosphate measured in the waters of the impoundment system (Table XIII) were comparable to those levels found in most uncontaminated surface waters. Sufficient phosphate was present to support the growth of Chara, a benthic alga. Some of the filamentous algae may require higher phosphate concentrations for optimal growth (Wetzel, 1975), since bacteria present in the impoundments would compete with the algae for available phosphate. The chemical conditions in the water would suggest the formation of phosphate complexes with metal ions and calcium (Syers et al., 1973). However, analyses of phosphate (Table XIII) indicated that the levels of this ion were low in the sediments (Syers et al., 1973). This may be due to the mobilization of the phosphate by a decreasing redox potential (Wetzel, 1975).

Suspended Particulates

Total Suspended Solids (TSS):

Table XIV tabulates the values obtained for suspended matter in the mine water samples and waters from the treatment facility. The values for suspended matter were variable with collection data. The variability in the values of total suspended particulates of the two mine effluents was probably due to variations encountered in the mineralogy of the deposit as mining progressed. Several TSS values obtained appeared to be erroneous; these were for Section 35 and 36 confluence, collected June 29, 1979, and algae pond #2 effluent, collected September 17, 1980. The impoundment system did serve effectively to remove particulates from suspension. Analyses from most collections indicated that particulate loads

TABLE XIII. Phosphate concentrations in waters and sediments collected from a uranium mine water treatment facility near Grants, New Mexico

Sample Location	Date of Collection		
	11/15/78	1/19/79	3/6/79
	Phosphate (mg/l)		
Water:			
Effluent - Sec. 35	ND	ND	0.04
Pond A-3 Effluent - Sec. 35	ND	ND	0.07
Pond A-4 Effluent - Sec. 35	0.06	ND	ND
Effluent - Sec. 36	0.07	ND	ND
Confluence - Sec. 35 and 36	0.99(?)	ND	ND
Algae Pond #1 Effluent	0.05	ND	ND
Algae Pond #2 Effluent	ND	ND	0.03
	Phosphate (%)		
Sediment:			
Pond A-2 - Sec. 35	ND	7.0×10^{-5}	ND
Pond A-4 - Sec. 35	ND	1.6×10^{-4}	ND
Algae Pond #2	ND	9.0×10^{-5}	ND
ND - Not Determined			
(?) - Data inconsistent, possible analytical error			

TABLE XIV. Total suspended solids in waters collected over a 4-year period from a uranium mine water treatment facility near Grants, New Mexico

Sample Location	Date of Collection								
	11/15/78	1/19/79	3/6/79	6/29/79	9/25/79	1/24/80	4/24/80	9/17/80	3/31/81
Total Suspended Solids (mg/l)									
Effluent - Sec. 35	14.5	135.8	351.0	133.5	158.4	96.4	15.7	74.1	111.4
Pond A-1 Effluent - Sec. 35	ND	ND	ND	ND	ND	ND	ND	ND	66.0
Pond A-2 Effluent - Sec. 35	7.3	5.8	54.8	56.8	56.8	55.0	40.7	20.6	57.5
Pond A-3 Effluent - Sec. 35	7.0	4.4	22.6	32.4	36.4	30.4	17.2	17.6	61.3
Pond A-4 Effluent - Sec. 35	7.0	22.6	29.6	29.6	30.4	19.6	14.4	9.1	55.6
Effluent - Sec. 36	12.4	334.1	298.0	184.8	17.2	283.0	731.3(?)	147.0	182.0
Pond B-1 Effluent - Sec. 36	0.9	ND	51.4	9.6	Dry	Dry	Dry	Dry	14.0
Pond B-2 Effluent - Sec. 36	0.2	3.8	44.0	3.2	4.0	46.4	36.7	32.5	5.0
Confluence - Sec. 35 and 36	0.2	8.6	23.4	360.0(?)	22.8	26.8	30.4	27.0	ND
Algae Pond #1 Effluent	1.0	0.8	44.4	32.8	15.6	25.2	20.0	12.3	Dry
Algae Pond #2 Effluent	2.6	7.8	67.6	5.2	6.8	10.4	6.8	101.1(?)	7.6
Algae Pond #3 Effluent	0.2	11.2	46.4	45.2	3.6	16.0	0.4	17.2	5.5

ND - Not Determined

(?) - Data inconsistent, possible analytical error

were reduced by more than 10-fold.

Uranium, Molybdenum and Selenium:

Analyses of suspended matter indicated that these particulates were enriched with uranium and to a lesser extent molybdenum and selenium. Whether the particulates represent the mineral or whether the suspended materials were clays or non-mineralized matter to which the inorganic contaminants were adsorbed was not determined. The suspended particulates assayed 0.07 to 8.4% uranium (Table VIII), 6.0×10^{-5} to 0.29% molybdenum (Table IX) and 1.0×10^{-7} to 0.57% selenium (Table X). One liter of effluent from algae pond #3 carrying a particulate load of $16 \text{ mg } \ell^{-1}$ (January 24, 1980) would contain 0.6 mg uranium and 0.01 mg molybdenum. The settling of particulates in the ponds may be responsible in part for the enrichment of the sediments with uranium, molybdenum and selenium.

Sediments

The sediments when collected were usually black. A strong smell of hydrogen sulfide was evident suggesting the sediments to be anoxic. Eh measurements of the sediments were negative confirming the anoxic condition.

Uranium, Selenium and Molybdenum:

Tables VIII, IX and X record the concentrations of uranium, molybdenum and selenium, respectively, found in the sediments of the ponds which constitute the mine water treatment facility. Although the concentration of uranium in solution decreases after the waters have passed through the ion exchange resins, this

decrease in solution concentration does not affect the uranium content in the sediments. The uranium content varied from 0.001 to 0.6%; the higher concentrations were frequently noted in the final impoundments of the system (Table VIII). The nature of the uranium in the sediments was not determined. Hexavalent uranium can complex with organic matter (Reuter and Perdue, 1977) and phosphates (Cotton and Wilkinson, 1972). In reducing environment hexavalent uranium may be reduced to the more insoluble tetravalent uranium (Lingane, 1966).

Like uranium, molybdenum concentrations in sediments (Table IX) showed no pattern of distribution; concentrations in the algae ponds were similar to those in the initial settling ponds. Values of molybdenum ranged from not detectable to 0.05%. Molybdenum content in sediments could be derived from the settling of mineralized particulates, the adsorption of soluble molybdate to amorphous iron oxyhydroxides (Kaback and Runnells, 1980), and the coprecipitation of MoO_4^{2-} or MoO_2^+ with iron sulfide (Bertine, 1972). Adsorption of molybdate to clays at the pH of the mine waters would be of little consequence in removal of molybdenum from solution (Theng, 1971).

Selenium content in sediments (Table X) also indicated that no pattern existed in the deposition of this metalloid. Selenium concentrations ranged from 5.7×10^{-5} to 0.02% throughout the impoundment. Selenium in sediments could be derived from the formation of insoluble basic ferric selenite (Howard, 1971; Lakin, 1973; Measures and Burton, 1978; Trudinger et al., 1979) and the adsorption of selenite to clays (Howard, 1971).

X-ray diffraction analysis of sediments failed to identify any specific crystalline forms of uranium, selenium and molybdenum suggesting that either concentrations of any crystalline compounds of these metal(oids) were so low as to be undetectable, or that any minerals formed in the sediments with these elements were of an amorphous nature.

Copper, Iron and Vanadium:

Copper concentrations in sediment samples (Table XI) ranged from 0.002 to 0.003%; this copper would be expected to be in a sulfide form since the sediments were anoxic and hydrogen sulfide was biologically produced.

The iron content of the sediments (Table XI) was generally high, 1.4 to 6.2%, suggesting that most iron present in the system was in an insoluble state in the sediments. Iron in this water/sediment system would be as an insoluble ferric hydroxide (Mason, 1966), basic ferric selenite (Howard, 1971; Lakin, 1973), or iron sulfide. The latter compound could be formed by the reaction of biologically produced hydrogen sulfide with reduced iron (Bertine, 1972).

Vanadium concentrations in the sediments (Table XI) ranged from 0.003 to 0.58%. These sediment concentrations could be derived from the formation of uranyl vanadate compounds, $VO(OH)$ (Hostetler and Garrels, 1962), and fixation by decomposing organic matter (Bloomfield and Kelso, 1976).

Sulfur:

The analysis of total sulfur in the sediments of the water

TABLE XV. Total sulfur concentration in sediment samples collected over a two-year period from a uranium mine water treatment facility near Grants, New Mexico

Sample Location	Date of Collection					
	1/19/79	3/6/79	6/26/79	9/25/79	4/24/80	9/17/80
Pond A-1 - Sec. 35	0.40	0.46	0.36	0.33	0.20	0.21
Pond A-2 - Sec. 35	0.30	0.45	0.39	0.33	0.54	ND
Pond A-3 - Sec. 35	0.98	1.19	0.58	0.90	0.75	ND
Pond A-4 - Sec. 35	0.46	0.67	0.09	0.63	0.62	0.62
Pond B-1 - Sec. 36	0.67	0.67	0.11	0.41	ND	2.42
Pond B-2 - Sec. 36	0.18	0.39	0.24	0.46	0.16	2.73
Algae Pond #1	0.70	1.21	0.99	0.82	0.88	1.90
Algae Pond #2	0.22	3.09	0.72	0.94	0.89	0.87
Algae Pond #3	0.69	1.37	0.85	0.88	0.86	1.01

ND - Not Determined

treatment facility (Table XV) indicated that concentrations range from 0.09 to 3.09%. In general, the sulfur values were slightly higher in the three algae impoundments. This may be attributable to the addition of barium chloride which precipitated sulfate. The form of the sulfur in the sediments was not defined, although due to the reducing conditions and high numbers of sulfate-reducing bacteria found in the sediments, the sulfur probably existed in reduced forms such as sulfur or metallic sulfides.

Core Samples:

The three core samples, collected at the middle, eastern and western locations of algae pond #2, were examined for color and texture variations, and analyzed for molybdenum, selenium, uranium and sulfur. The description of these cores and the assays of the elements are summarized in Table XVI. A very thin oxidized zone was evident at the top of each core. The next 23 to 34 cm of core were black indicating anoxic conditions. The final 4 to 8 cm of core were brown or grey suggesting that the original basin material had been reached with the coring device. Analyses indicated that the concentrations of molybdenum, selenium, uranium and sulfur were nearly uniform throughout the core, including the lower regions which appeared to be original basin material. The metal and sulfur values were similar to those recorded for sediment grab samples.

TABLE XVI. Chemical analyses of core samples collected from the basin of Algae Pond #2 of a uranium mine water treatment facility

Core	Core Section	Description	%			
			Mo	Se	U	S
East	E-1	0 - 0.1 cm grey veneer	ND	1.4×10^{-3}	1.9×10^{-1}	ND
	E-2	0.01- 5.1 cm soft black	5.4×10^{-2}	5.5×10^{-4}	3.6×10^{-2}	4.0×10^{-2}
	E-3	5.1 -14.0 cm solid grey	1.2×10^{-3}	1.2×10^{-4}	3.4×10^{-2}	2.8×10^{-1}
	E-4	14.0 -34.3 cm soft black	3.1×10^{-3}	1.1×10^{-3}	3.4×10^{-2}	1.6×10^{-1}
	E-5	34.3 -38.0 cm brown sand				
Middle	M-1	0 - 3.8 cm grey veneer	1.6×10^{-3}	2.5×10^{-4}	1.7×10^{-2}	3.4×10^{-1}
	M-2	3.8 - 6.4 cm black sand	1.3×10^{-2}	1.6×10^{-3}	6.2×10^{-2}	8.0×10^{-2}
	M-3	6.4 -12.7 cm brown/grey sand	ND	ND	ND	ND
	M-4	12.7 -19.1 cm black sand	2.8×10^{-2}	2.8×10^{-4}	6.8×10^{-2}	2.1×10^{-1}
	M-5	19.1 -19.1 cm brown veneer	ND	ND	ND	ND
	M-6	19.1 -24.1 cm soft black sand	ND	ND	ND	ND
	M-7	24.1 -27.9 cm brown sand	ND	ND	ND	ND
	M-8	27.9 -28.6 cm soft black	ND	ND	ND	ND
	M-9	28.6 -36.8 cm grey sand	1.7×10^{-3}	6.6×10^{-4}	3.5×10^{-2}	2.0×10^{-2}
West	W-1	0 - 7.6 cm irregular banding	5.4×10^{-3}	7.8×10^{-4}	5.1×10^{-2}	2.1×10^{-1}
	W-2	7.6 -12.7 cm black sand	1.1×10^{-2}	7.0×10^{-4}	9.0×10^{-2}	3.8×10^{-1}
	W-3	12.7 -22.2 cm grey with black flecks	2.5×10^{-2}	2.2×10^{-3}	6.8×10^{-2}	1.0×10^{-1}
	W-4	22.2 -22.9 cm soft black	ND	ND	ND	ND
	W-5	22.9 -30.5 cm solid brown	5.6×10^{-3}	1.0×10^{-4}	2.5×10^{-2}	1.7×10^{-1}

ND = Not Determined

CONCLUSIONS

Over a four-year period water, suspended matter, sediments and cores were collected and analyzed for several physical-chemical parameters, selected metals, metalloids, and elements of nutritional interest. These data were evaluated for evidence of partitioning of trace contaminants between the water and the sediments. Processes involved in partitioning of trace contaminants were suggested.

Conclusions derived from the analytical data were:

1. The concentrations of soluble uranium, selenium and molybdenum were not diminished in the mine waters by passage through the series of impoundments which constituted the mine water treatment facility. Uranium concentrations were reduced but this was due to passage of the water through an ion exchange column.
2. The particulate concentrations of the mine water were reduced at least ten-fold by passage of the waters through the impoundments. Since uranium, selenium and molybdenum were associated with the suspended particulates, reduction in the concentration of total suspended solids reduced the concentration of contaminants in the final effluent.
3. The ponds were well oxygenated. This was probably due to the shallow depth of the ponds and growth of algae.
4. The pH remained near neutral during all collections

and this would indicate that the major soluble species of trace contaminants would be molybdate, uranyl carbonate species selenite (and possibly selenate at the higher pH values).

5. The temperature remained higher than 10°C in winter suggesting that plant and microbial life could remain active and that the volume of water was great enough to lessen large temperature fluctuations.
6. Phosphate and nitrate were present in high enough concentrations to support limited algal and microbial activity.
7. The sediments were anoxic and enriched in uranium, molybdenum and selenium. The deposition of particulates and the formation of insoluble compounds were proposed as mechanisms for sediment enrichment.

REMOVAL OF URANIUM AND MOLYBDENUM FROM WASTEWATERS BY ALGAE

INTRODUCTION

Wastewaters from industrial and mining operations often contain heavy metals in concentrations too low to warrant recovery by conventional extractive techniques, but which must be reduced to maintain water quality standards in discharged effluents (Kelly, et al., 1979). Usually a number of elements must be dealt with in one treatment system, so that a nonspecific method of removal is desirable. Several water treatment systems have been developed to take advantage of the metal-concentrating ability of algae. Various algae have been used to accumulate heavy metals from dilute solution in the treatment of lead mine effluents (containing lead, zinc, copper and manganese) (Gale and Wixson, 1979), zinc mine effluents (zinc, cadmium and copper) (Jackson, 1978), and municipal wastewaters (copper, chromium and cadmium) (Filip, et al., 1979).

While algae are able to accumulate heavy metals both as living and as dead material (Ferguson and Bubela, 1974; Gutknecht, 1965; Jennett, et al., 1979), the metals often are not irreversibly bound to the algal material. The retention of heavy metals in treatment systems may be influenced by interactions between the algal-bound metals and sediment. In many cases, the presence of algal material in sediment seems to enhance retention of heavy metals (Jackson, 1978). However, other studies have suggested that algal material may also mobilize some metals from sediment (Laube, et al., 1979). It is clear that development of an effective

treatment system depends on knowledge not only of the accumulation of the metals in question by the algae in the system but also of the retention or release of the metals as the algae decay in the presence of the pond or stream's sediment.

This section reports studies on the role of algae in removing uranium and molybdenum from minewaters in a treatment system developed at the Kerr-McGee Corporation near Grants, New Mexico. Part of the treatment system consists of algae ponds through which the minewaters pass prior to discharge. One purpose of this study was to determine field levels of uranium and molybdenum in the most common algae in the ponds. Laboratory studies included short-term exposure of two of the pond algae, Chara and Spirogyra spp., to uranium and molybdenum solutions to study accumulation in living and dead cells. Also, interactions between algae and sediment were followed in long-term laboratory studies in which the algae, added either as living or as dead material to metal solutions, were allowed to decay in contact with pond sediment.

MATERIALS AND METHODS

Site Description

The wastewater treatment system consists of a series of ponds which receive water pumped from two underground mines at a rate of 2×10^6 gallons per 24 hours from each. Barium chloride is added to water from both mines prior to entry into the algae ponds, in order to coprecipitate radium as radium sulfate. Water from one mine passes through an ion-exchange plant to remove uranium prior to combining with water from the other mine. The residence time

for the combined waters in the three algae ponds is about 2.5 days, based on a volume of 9×10^6 gallons (1.25×10^5 ft³) in the three ponds divided by the daily input of 4×10^6 gallons.

The average concentration of uranium in the algae pond water is 0.8 ppm and of molybdenum, also 0.8 ppm (Brierley and Brierley, 1980). The sediments contain 1190 ppm uranium and 310 ppm molybdenum. The pH of the water averages 7.7 - 7.8.

The pond sediments provide a reducing environment (Eh, -350 mV) for a large population of sulfate-reducing bacteria of the genera Desulfovibrio and Desulfotomaculum (Brierley and Brierley, 1980). In the summer months between June and September, the pond perimeters support populations of Typha, Juncus, and sedges, which die back in the winter months.

The predominant algae in the ponds are the macrophytic green Chara, the filamentous green alga Spirogyra, and the filamentous blue-green Oscillatoria. Rhizoclonium, another filamentous green alga, is found at the inflow of algae pond 1 during the summer. Unidentified diatoms and unicellular green algae are associated with the floating mats of filamentous algae and with the bottom-growing Chara. These associated algae are most abundant in the summer months.

Collection and Laboratory Culture

Algae samples were collected from all three algae ponds in September, 1979, January, 1980, and April, 1980. Samples were collected from the edge of the ponds, given a preliminary wash in pond water to remove excess particulate material, and stored in nonsterile polyethylene bottles in ice for transport to the

laboratory. After further washing in deionized water, the algae were either dried for metal analyses or transferred to aquaria for laboratory culture.

The algae were grown for several weeks in the laboratory before being used as experimental material. The algae were grown in mixed culture in 10 l aquaria containing Shen's medium (Shen, 1971) with 0.1 g l^{-1} NaHCO_3 added to Chara cultures (Forsberg, 1965). About 1% activated charcoal was added to the media to remove possibly toxic growth by-products (Shen, 1971). The algae were grown without aeration. Illumination (35-40 fc) was provided continuously (Forsberg, 1965). The temperature, which ranged from 18°C to 25°C , averaged 23°C .

Algae Digestions

In order to determine the metal content in field-collected algae, samples were prepared for uranium and molybdenum analyses by overnight digestion in concentrated HNO_3 at 85°C , followed by addition of 30% H_2O_2 and digestion at 125°C . Samples were filtered through $0.45 \text{ }\mu\text{m}$ Millipore filters and brought to volume with distilled water. Blanks without algae were also run.

24-Hour Uptake Experiments

Removal of molybdenum and uranium from solution by Chara and Spirogyra was tested in 24-hour uptake experiments. The algae were washed in deionized water, dried on paper toweling, and weighed out in 1 g aliquots. Dry weight determinations were made from representative samples. Algal material was added to duplicate flasks either as whole cells or as particulate material produced by grinding the algae one minute in a Sorvall Omni-Mixer (Ferguson)

and Bubela, 1974). To prepare test flasks, 100 ml Shen's medium or pond water was dispensed into 250 ml Erlenmeyer flasks and the pH adjusted with 1N NaOH or 1N HCl to 7.8. After the algae were added, the flasks were spiked with stock uranium ($\text{UO}_2\text{SO}_4 \cdot 3\text{H}_2\text{O}$) and molybdenum ($\text{Na}_2\text{MoO}_4 \cdot \text{H}_2\text{O}$) solutions to produce 5-10 ppm U and 2.5-5 ppm Mo, depending on the experiment. The pH was then readjusted to 7.8-8.0. Flasks without algae were run as controls. The experiments were carried out in stationary flasks incubated 24 hours in light.

The amounts of metals remaining in solution were determined after filtering the media through 0.45 μm Millipore filters to remove algal material. It was necessary to centrifuge the particulate suspensions for 10 minutes at 4,340xg before filtering. The solutions were acidified with 1.5% nitric acid before analysis.

Long-Term Experiments

Long-term interactions between algae and sediment were modeled using 2 ℓ culture vessels containing 1 ℓ medium, spiked with uranium and molybdenum, and either growing or killed algae. In experiment I, 5 g wet weight living Chara (1.1 g dry weight) or Spirogyra (0.4 g dry weight) was added to duplicate containers of Shen's medium (pH 7.8) containing 5 ppm U and 2 ppm Mo. A 14-day period of growth in light was followed by 152 days in the dark. At the beginning of the dark phase two of the algae containers and two of the control containers were given additions of 150 g sediment collected from the treatment ponds.

In experiment II, the amount of sediment was increased to 1000 g, and 20 g (dry weight) of air-dried Chara was used. The

entire run of 190 days was conducted in the dark. The pond water (pH 8.1) used in the experiment was spiked with 20 ppm U and 5 ppm Mo.

The pH was monitored throughout the tests, and Eh measurements were taken during the latter period of experiment II. Concentrations of uranium and molybdenum in the media were monitored by periodic removal of 100 ml of solution, which was filtered and acidified before metal analysis. The 100 ml aliquot was replaced with an equal volume of medium containing the initial metal concentrations.

Analytical Procedures

Uranium concentrations in digested algae or in water samples were determined colorimetrically by the TOPO extraction procedure (Johnson and Florence, 1971). Molybdenum was assayed colorimetrically by the thiocyanate procedure (Meglan and Glaze, 1973).

RESULTS

Uranium and Molybdenum in Field-Collected Algae

The results of analyses for three collections of algae are summarized in Table XVII. Table XVIII tabulates the mean U and Mo values for filamentous algae (Spirogyra, Oscillatoria, and Rhizoclonium samples) and for Chara. These values represent average analyses of samples collected from all three ponds at each collection date.

Levels of molybdenum and uranium were higher in filamentous algae than in Chara by 2 to 3 times for uranium and about 2 times for molybdenum. Wide variation in both molybdenum and uranium levels were found; uranium ranged from a low of 330 ppm (Chara, Sept.) to 3100 ppm (filamentous, Jan.), and molybdenum ranged from

TABLE XVII. Uranium and molybdenum levels in field-collected algae

Algae	Algae Pond Location	Date of Collection		
		September	January	April
Uranium (ppm)				
<u>Chara</u>	pond 2	544±439 (7) *	580 (1)	375± 25 (2)
	pond 3	330±285 (2)	NC**	580 (1)
<u>Spirogyra</u>				
<u>Oscillatoria</u>	pond 1	NC	1850±400 (4)	2015± 15 (2)
	pond 2	870± 90 (3)	2670±530 (4)	1700±420 (3)
	pond 3	NC	3100±300 (2)	1150 (1)
<u>Rhizoclonium</u>	pond 1	1420± 50 (2)	NC	1700±100 (2)
Molybdenum (ppm)				
<u>Chara</u>	pond 2	22± 20 (2)	0 (2)	40± 4 (2)
	pond 3	0 (2)	NC	4± 0 (2)
<u>Spirogyra</u>				
<u>Oscillatoria</u>	pond 1	NC	320±150 (4)	70± 17 (2)
	pond 2	27± 16 (3)	270±200 (4)	53± 8 (4)
	pond 3	NC	120± 50 (2)	35± 1 (2)
<u>Rhizoclonium</u>	pond 1	31± 6 (2)	NC	30± 11 (2)

* Number in parenthesis indicates sample size

** NC = no collection

TABLE XVIII. Uranium and molybdenum levels in field collected algae
(data from three ponds averaged)

Algae	Date of Collection					
	September		January		April	
	U (ppm)	Mo (ppm)	U (ppm)	Mo (ppm)	U (ppm)	Mo (ppm)
<u>Chara</u>	500±390	16±19	580	0	440±120	22±21
<u>Spirogyra</u>						
<u>Oscillatoria</u>	1090±310	29±12	2430±670	260±190	1710±350	48±18
<u>Rhizoclonium</u>						

undetectable levels in some Chara samples to a high of 320 ppm in the filamentous algae collected in January. Generally, in a given algal sample the uranium concentration was about 10 times higher than the molybdenum concentration.

Some seasonal variation was seen in the filamentous algae, but this variation was not evident in Chara. A one-way analysis of variance for uranium and molybdenum levels in filamentous algae by month showed significant variation at the 0.01 level. The levels of uranium were significantly different for all months, with levels increasing in the order September < April < January. Molybdenum concentrations were significantly higher in January samples; the difference in concentrations noted between September and April samplings was not significant. There was no correlation between the metal content of a sample and the pond from which it was collected.

24-Hour Uptake Experiments

Uptake of uranium and molybdenum on a short-term basis was studied in Chara and Spirogyra in 24-hour laboratory uptake experiments. Results of the tests are given in Table XIX.

Only one experiment (3A, Table XIX) showed that Chara could take up detectable levels of uranium or molybdenum. The detection of uranium and molybdenum in field-collected specimens indicates that Chara does have the ability to accumulate the metals from solution, but the conditions of the short-term uptake studies evidently did not allow uptake or only at levels below detection.

Spirogyra preparations adsorbed both uranium and molybdenum from solution (Table XIX). In every case, disruption of the cells

TABLE XIX. 24-hour uptake of Mo and U by Chara and Spirogyra

Experiment	U (ppm)	% Removed	mg U/g algae*	Mo (ppm)	% Removed	mg Mo/g algae*
1						
<u>Spirogyra</u> in Bristol's	10.9±1.4			2.5±0.1		
Control	7.8±0.0	28	3.1	2.7±0.0	13	0.4
Whole	1.9±0.5	82	9.0	2.4±0.3	22	0.7
Particulate						
2A						
<u>Spirogyra</u> in Shen's						
Control	21.4±0.8			4.9±0.1		
Whole	13.5±0.1	37	7.9	4.8±1.2	0	0
Particulate	6.2±0.1	71	15.2	4.2±0.6	14	0.7
2B						
<u>Spirogyra</u> in pond water						
Control	23.9±1.7			4.5±0.1		
Whole	17.9±0.3	25	6.0	4.9±0.2	0	0
Particulate	5.2±1.2	78	18.7	4.3±0.5	4	0.2
3A						
<u>Chara</u> in Shen's						
Control	10.1±0.1			2.2±0.1		
Whole	8.2±2.6	19	0.9	2.7±0.4	0	0
Particulate	8.3±2.5	18	0.9	2.2±0.2	0	0
3B						
<u>Chara</u> in pond water						
Control	9.7±0.4			2.4±0.1		
Whole	9.9±1.3	0		2.5±0.1	0	0
Particulate	10.0±1.1	0		2.5±0.2	0	0

*Obtained by dividing the amount in mg of U or Mo removed from solution by the dry weight of algae per flask

by omni-mixing increased the adsorption of the ions. The pattern of removal of both metals by the Spirogyra preparations is strikingly similar in the different media employed in the tests. Disrupting cells increased uptake of uranium 2- to 3-fold in each case. Increasing the external concentration of uranium did not decrease the percentage uptake, so that the total amount of adsorbed uranium was higher at the higher external concentrations. Doubling the concentration of molybdenum in solution did not increase the amount adsorbed, and in fact, the percentage uptake was lower at the higher external concentrations. Disruption of cells increased the amount of molybdenum adsorbed, though on a smaller scale than for uranium.

The material used for the 24-hour studies consisted of living cells, which were left intact in the whole preparations and killed only in the omni-mixed preparations. After the 24-hour incubation period, the whole preparations retained their cellular integrity and appeared normal. The particulate suspensions began to lose their pigmentation after 24 hours.

Long-Term Experiments

The effects of cell growth and subsequent decay on metal uptake by algae were followed in the first long-term study, while the second study involved only the decay period. Results of these experiments are tabulated in Tables XX and XXI.

In experiment I (Table XX), Spirogyra and Chara were grown for the first 13 days in light. The Spirogyra cultures contained some Oscillatoria, which lysed within 1-4 days, giving the medium a faint brown color. The Chara cultures showed new growth

TABLE XX. Uptake of U and Mo by Chara and Spirogyra
(Long-term Experiment I)

Day	Parameter	ppm					
		Control		<u>Chara</u>		<u>Spirogyra</u>	
0	Uranium	5.8±1.9		5.8±0.8		5.3±2.1	
	Molybdenum	2.2±0.3		1.9±0.2		2.3±0.2	
	pH	7.4		7.8		7.8	
3	Uranium	5.1±2.2		6.7±0.9		4.2±0.7	
	Molybdenum	2.2±0.2		2.3±0.2		2.0±0.7	
	pH	7.4		7.7		7.8	
7	Uranium	3.3±0.6		5.3±0.9		3.5±1.2	
	Molybdenum	2.2±0.2		2.2±0.2		1.9±0.3	
	pH	7.4		8.0		7.9	
13	Uranium	3.0±0.3		5.5±1.2		2.1±0.3	
	Molybdenum	2.9±0.6		2.2±0.2		1.9±0.4	
	pH	7.4		8.0		7.7	
		No Sediment	Sediment	No Sediment	Sediment	No Sediment	Sediment
14	Uranium	4.3±0.5	6.0±1.5	7.8±0.1	8.0±1.0	3.8±0.8	3.5±0.8
	Molybdenum	1.9±0.1	2.2±0.0	2.0±0.1	2.4±0.0	1.4±0.1	1.9±0.1
	pH	7.4	7.7	7.8	7.9	7.5	7.7
21	Uranium	2.7±0.5	4.6±0.6	6.3±1.2	3.2±0.0	2.0±0.1	1.2±0.2
	Molybdenum	2.4±0.0	2.0±0.5	2.5±0.0	2.3±0.0	2.5±0.0	1.0±0.1
	pH	7.4	8.1	7.6	7.8	7.7	7.6
49	Uranium	3.7±0.1	5.2±0.0	6.5±0.3	2.0±0.0	1.7±0.6	1.5±0.2
	Molybdenum	2.3±0.0	2.7±0.1	2.9±0.6	1.8±0.3	1.6±0.1	1.5±0.3
	pH	7.4	7.7	7.8	7.8	7.8	7.6
80	Uranium	4.8±1.1	5.5±0.4	7.2±0.5	4.2±0.9	2.5±0.3	4.3±1.1
	Molybdenum	2.1±0.0	2.8±0.1	2.3±0.1	1.8±0.5	2.2±0.3	2.7±0.2
	pH	7.6	7.6	7.6	7.6	6.0	7.6
166	Uranium	4.8±0.7	3.8±0.5	5.5±0.2	3.8±1.1	0.6±0.0	2.1±0.5
	Molybdenum	2.9±0.3	2.3±0.2	3.8±0.1	4.1±1.4	3.2±0.2	4.7±0.3
	pH	-	7.4	7.3	-	5.9	7.7

TABLE XXI. Uptake of U and Mo by Chara
and sediment in darkened cultures
(Long-term Experiment II)

Day	Condition	U (ppm)	Mo (ppm)	pH
2	Sediment	24.6±0.1	6.3 ±0.5	
	Algae	15.3±2.5	7.3 ±0.6	
	Sediment+Algae	12.8±0.5	4.2 ±0.2	
16	Sediment	8.6±0.4	4.2 ±0.5	7.61
	Algae	7.2±0.3	2.6 ±0.2	7.31
	Sediment+Algae	1.0±0.2	0.4 ±0.4	7.23
47	Sediment	2.6±0.3	2.7 ±0.4	7.75
	Algae	4.1±1.1	3.1 ±0.1	7.50
	Sediment+Algae	0.3 -	0.06±0.05	7.80
108	Sediment	1.2±0.3	1.4 ±0.4	7.62
	Algae	3.9±1.2	3.0 ±0.0	7.72
	Sediment+Algae	1.0±0.4	0.03±0.01	8.02
190	Sediment	0.7±0.0	1.7 ±0.1	7.70
	Algae	1.1 -	3.2 ±0.3	7.79
	Sediment+Algae	1.9±0.3	1.0 ±0.0	7.90

*All cultures were spiked at day 0 with 20 ppm U and 5 ppm Mo

throughout the 13-day light period, while the Spirogyra cultures were observed to decay at the end of the period. The Spirogyra containers, after a week of culturing, developed a surface growth of blue-green algae, predominately Lyngbya sp., but overgrowth of Chara was not observed. By day 21, a week after addition of sediment and placement in the dark, the control sediments without algae had a light, oxidized surface layer, while the sediments with algae were black throughout, indicating sulfate-reducing bacterial activity. By day 49, the blackening of the sediment surface and the presence of intact algae cells were no longer evident in the containers with algae and sediment.

Removal of uranium was most pronounced in the Spirogyra cultures (Table XX). While the presence of sediment did not enhance the removal of uranium from solution in comparison to the sediment control, the algae increased the sediment's ability to retain uranium. At day 166, 2.1 ppm uranium remained in solution in the Spirogyra-sediment cultures compared to 3.8 ppm in the sediment control.

In the Chara cultures, growing algae had no effect on uranium removal, and some release of uranium from Chara seemed to have occurred when the containers were transferred to the dark (Table XX, days 0-14). However, as Chara decayed in the presence of sediment, levels of uranium fell from 8.0 ppm at day 14 to 2.0 ppm at day 49. Lessened decay of the algae after day 49 allowed reestablishment of oxidizing zone at the sediment surface, which coincided with partial remobilization of uranium. The similarity of day 80 and day 166 values (4.2 ppm and 3.8, respectively)

suggests that an equilibrium had been established in the system.

No cultures in experiment I showed irreversible removal of molybdenum, although Spirogyra cultures reduced molybdenum solution levels substantially by day 21. However, molybdenum levels returned to original values in solution in all cultures and these levels were, in fact, higher than the initial levels in the algae and sediment cultures.

Experiment II (Table XXI) was intended to magnify the effect of decaying algal material on sediment retention of uranium and molybdenum. By day 16, bacterially-mediated decay was vigorous in the algae cultures, which were heavily overgrown with a surface layer of bacteria. The algae plus sediment cultures were blackened throughout the solution and sediment, while the sediment-alone cultures were blackened only beneath the surface of the sediment. High bacterial activity was evident by visual inspection even after 47 days. However, after day 74 the algae cultures had lost the blackened appearance, and the surface masses of bacteria were no longer evident. In the sediment plus algae cultures, the algae and sediment surfaces were still blackened, but an oxidized layer had formed on the sediment-alone. The Chara cells remained partially intact even at the end of the test, though most of the algal material had disintegrated. Table XXII gives Eh values in the cultures for days 74 through 190. Both water and sediment were reducing at day 74, but by day 108 only the sediment remained reducing.

The percentage removal of the 20 ppm uranium and the 5 ppm molybdenum spikes which were added to Chara cultures maintained

TABLE XXII. Eh measurements of Chara
and sediment in darkened cultures
(Long-term Experiment II)

Day	Eh (mv)				
	Sediment		Algae	Sediment+Algae	
	Water	Sediment	Water	Water	Sediment
74	-204±5	-502±46	-415±5	-302± 2	-515± 35
108	+150±4	-339±63	+107±2	+88± 1	-392± 23
190	+68±1	-382±80	+70±0	+50±25	-393±105

in the dark is shown in Table XXIII. Initial release of uranium from sediment and from algae was seen at day 2. Sediment alone removed more uranium and molybdenum than algae alone, but the combination of sediment plus algae increased removal of uranium to 95% and of molybdenum to 99%. Removal of both metals was essentially complete after 16 days in the algae plus sediment cultures, but some release of both occurred by day 190. This release was not observed in either the sediment alone or the algae alone.

TABLE XXIII. Percent of the U and Mo removed by Chara
and sediment in darkened cultures
(Long-term Experiment II)

Day	% Removal					
	Sediment		Algae		Sediment+Algae	
	U	Mo	U	Mo	U	Mo
2	+23	+26*	23	46	36	16
16	57	16	64	48	95	92
47	87	46	79	38	98	99
108	94	72	80	40	95	99
190	96	66	94	36	90	80

*Plus sign indicates a percentage increase over the amount of spike added at day 0; values otherwise represent a percentage decrease.

DISCUSSION

The marked differences in accumulation of uranium and molybdenum by the different algae in the pond system may be due to the different chemistry of the two metals; but the roles of the metals in the algal life cycle may also play a part in determining their accumulation.

Molybdenum is probably present in the pond water as the anion MoO_4^{2-} (Bloomfield and Kelso, 1973), and its accumulation by direct adsorption onto negatively charged algal cell surfaces seems unlikely. Bloomfield and Kelso (1973), however, do point to the suggestion of Szalay (1969) that molybdenum is reduced by organic matter to exchangeable cationic forms, so that adsorption of molybdenum may occur in algae.

Molybdenum can be an essential trace element for green algae, and its requirement for those blue-green algae which fix nitrogen has been demonstrated (O'Kelly, 1974). It is possible that cells requiring molybdenum would have mechanisms to regulate levels of the metal in the cell interior. Chara in particular shows little variation in molybdenum levels. While a regulatory system for molybdenum has not been demonstrated in Chara, Robinson (1969) has found active uptake of sulfate ions into the vacuole of Chara australis by a pump across the plasmalemma, which might provide a pathway for uptake of MoO_4^{2-} as well. In the field-collected algae, levels of molybdenum varied 10-fold with different collections, which may be due to adsorption onto cells in addition to uptake into the cells. The ability of Spirogyra to adsorb molybdenum on a short-term basis was indicated by the 24-hour

uptake experiments, where an increase in surface area led to an increase in removal of molybdenum from solution. However, the different levels in the collections may also be due to varying populations of algae over the year, especially since the winter collection, which showed higher molybdenum content, also contained a higher proportion of the blue-green Oscillatoria.

In contrast to molybdenum, uranium is generally considered an abiological element (Taylor, 1979), and its uptake is more likely to be governed by physical-chemical factors than by active cellular processes. Justyn and Stanek (1974) reported that the filamentous algae, Cladophora, Oedogonium and Rhizoclonium, accumulate uranium by binding the ion to cellular surfaces. The uranyl ion has an extremely high affinity for organic material (Jackson, Jonasson and Skippen, 1978), and adsorption onto the negatively charged algal cell surfaces probably accounts for the high levels of uranium in the pond algae. Chlorella will absorb uranium intracellularly (Horikoshi, et al., 1979), but this uptake is probably independent of cellular metabolism since the uranium accumulated by the living cell can be removed by washing the cells with EDTA. Heat killed Chlorella will also accumulate large quantities of uranium intracellularly. Chara shows a lower affinity for uranium than the filamentous algae. In a study of radionuclide accumulation by Chara species, Marchyulene (1978) suggested that the presence of high levels of calcium carbonate compounds in the cell wall reduced the number of cation exchange sites in Chara compared to other algae. Sikes (1978) noted that in another calcium-accumulating alga, Cladophora, calcium carbonate

increased with the age of the cells, and this calcium was not subject to appreciable ion exchange. It is possible that uranium associated with Chara may be liebegite, $\text{Ca}_2\text{UO}_2(\text{CO}_3)_3 \cdot 9\text{H}_2\text{O}$ (Koval'skiy and Vorotnitskaya, 1965).

The seasonal variation in both uranium and molybdenum levels in the filamentous algae suggests that adsorptive processes are important in the accumulation of the metals in the algae cells, since extent of adsorption depends not only on the amount of metal available per unit of surface area but also on the length of exposure of the surface to the metal. Thus, longer-lived cells would be exposed to more metals than short-lived cells. The September collections represent quickly growing populations, while the January collections were taken from sparser populations which, due to the slower growth rate in winter, had a longer turnover time than the summer populations. April may represent a transition from chiefly perennial populations to annual summer blooms of algae. Knauer and Martin (1973) found that levels of heavy metals in marine phytoplankton were low during periods of algal blooms due to dilution of the amount of metal available per unit mass of phytoplankton. While the algae ponds in this study did support denser populations in the summer, the increase in cell number probably was not great enough to alter the ratio of metal to algae. More important is the increased length of exposure time for the winter populations. Hodge, Koide and Goldberg (1979) found that marine macroalgae adsorbed uranium, plutonium, and polonium in direct relationship to exposure time. The longer exposure could also lead to exchange absorption into the cell interior, as

described in the long-term exposure of Cladophora to lead (Gale and Wixson, 1979).

The results of the 24-hour uptake experiments support the field evidence for different interactions between the metals and the different algae. Short-term uptake was not observed in Chara, which accumulated both metals at much lower levels than the filamentous algae in the field. In the Spirogyra 24-hour test, the cell material showed a limited capacity to adsorb molybdenum, while uranium uptake increased with higher external concentrations. The disruption of the cells to form particulate suspensions evidently increased surface area for binding, although release of cellular constituents, which may form insoluble complexes, might also have been a factor (Ferguson and Bubela, 1974). Horikoshi *et al.* (1979) also observed an increase in adsorption of uranium in disrupted cells; in an 8 ppm solution of uranium, accumulation increased from 15,600 ppm in living Chlorella to 67,200 ppm in heat-killed cells.

The long-term laboratory studies indicated that the pond algae, in the form of particulate, decaying material, can be instrumental in removing metals from solution. However, the patterns of retention and release of uranium and molybdenum as the algae decayed in the presence of sediment indicated that maintenance of reducing conditions in the sediment or in the algal cultures is critical to the sequestering of the metals. In the model systems, the period of algal decomposition was associated with increased bacterial activity and an enhancement of reducing conditions in the sediment-containing cultures. The algae culture

without sediment (experiment I, Table XX) probably decomposed mainly in aerobic conditions, while in experiment II (Table XX) the high proportion of algal material led to reducing conditions in the first two months of incubation. When sulfate levels are high, as they are in the pond water, anaerobic decomposition of algae is accompanied by sulfate reduction even in the absence of sediment (Foree and McCarty, 1970). Decomposition was associated in the model systems with removal of molybdenum and uranium from solution, but the period following decomposition was characterized by the partial to complete release of the metals back into solution. The release of molybdenum was surprising, since sulfides which are formed during sulfate reduction can form highly insoluble molybdenum disulfide. It is possible that molybdenum was precipitated in the reduced Mo(IV) state but did not form the sulfide mineral, so that release occurred as molybdenum was re-oxidized. However, molybdenum showed little or no release in experiment II (Table XX), although oxidizing conditions were established in the water compartment and at the sediment surface for at least the last 82 days of the experiment.

In most cases, the addition of algae to sediment increased the sediment's ability to retain uranium. Reduction of uranium to the insoluble U(IV) ion may have contributed to the removal, with adsorption onto the organic material another possibility (Leventhal, 1980). Taylor (1979) has pointed out that in sediments, the production of hydrogen sulfide by sulfate-reducing bacteria may increase the adsorption of uranyl ion onto organic material present in the sediment, since iron and other sulfide-forming

metals could be desorbed from the organic material to increase adsorption sites for uranyl ion.

The implication from the laboratory studies is, that while the algae are instrumental in removing metals from solution, the process is reversible unless the system contains substantial organic material. Also, while organic material accelerates the rate of removal and sometimes the extent of removal from water, retention of the metals in sediments is also reversible unless the system contains a high volume of sediment. These conclusions point to major problems in improving the existing pond system in respect to removal of uranium and molybdenum.

In the algae ponds of this study, there is no significant reduction of uranium concentration in solution in any of the algae ponds or indeed between the influent to the algae ponds and the final effluent. The case of molybdenum is similar. There is no significant reduction of molybdenum in solution throughout the system. Although the sediments concentrate both metals substantially over concentrations in water, the amount of metals removed is not substantial enough to be reflected in the water concentrations.

It is important when considering metal removed by algae to remember the volume of water which passes through the system yearly. At a combined inflow of 4×10^6 gallons a day, or 15×10^6 liters a day, the pond system receives 5.5×10^9 liters every year. Based on the uranium and molybdenum values in the influent to the algae ponds of 0.8 ppm for each metal, this volume amounts to 4.95×10^9 mg (4.95 metric tons) each of molybdenum and uranium

entering the algae ponds yearly. The filamentous algae present in the ponds now accumulate an average of 2000 ppm uranium and 130 ppm molybdenum on a dry weight basis. Given this level of removal, it would take 4.95×10^9 mg U \times (10^3 g algae/2000 mg U) = 2.5×10^9 g dry weight algae produced per year to remove the uranium entering the algae ponds. If the ponds were fertilized to increase productivity, could this amount of algae be grown in the existing pond system? Wetzel (1975) found that a hypereutrophic lake produced $570 \text{ g C m}^{-2} \text{ yr}^{-1}$. Using a common value found for carbon content in algae of 40% of dry weight (Ferguson and Bubela, 1974), 570 g C corresponds to a dry weight of algae of $1425 \text{ g m}^{-2} \text{ yr}^{-1}$. In order to grow 2.5×10^9 g algae yr^{-1} , the amount needed to accumulate the influent uranium, the pond system would have to be expanded to $2.5 \times 10^9 \text{ g} \times (\text{m}^2/1425 \text{ g}) = 1.75 \times 10^6 \text{ m}^2$, or 17.5 hectares. The ponds now cover 0.15 hectares. Obviously, relying on algal removal alone will not answer the problem of improving the pond system.

Increasing pond productivity may improve removal indirectly, as suggested by the long-term laboratory studies. The ponds are fairly unproductive now, which is typical of the early to middle stages of succession in Chara ponds where phosphate levels are quite low (Crawford, 1979). Later stages of Chara succession are characterized by overgrowth of planktonic algae and higher plants, which increase pond productivity. Additions of phosphate and nitrogen-containing fertilizers would accelerate the replacement of Chara with more productive annual green and blue-green planktonic algae. Promoting eutrophication of the pond system

would increase the amount of organic substrate available for sulfate-reducing bacteria and would promote reducing conditions in the pond sediments. Laboratory experimentation has indicated that enhancement of growth of Desulfovibrio and Desulfotomaculum and thereby of sulfate reduction by these bacteria in sediments resulted in removal of uranium, molybdenum and selenium from solution (Brierley and Brierley, 1980). It is possible that, while the algae cannot function alone to remove excess trace contaminants, the effect of increased algal productivity on water and sediment chemistry might be significant.

BACTERIAL MECHANISMS FOR REMOVAL
OF SELECTED INORGANIC POLLUTANTS
FROM URANIUM-MINE WASTEWATER

INTRODUCTION

Microorganisms are effective agents in concentration of metals from solutions (see Kelly, Norris, and Brierley, 1979, a recent review of the topic). Norris and Kelly (1979) found yeasts to be more efficient than bacteria in gross removal and accumulation of nickel and copper. Bacteria will concentrate potassium, manganese, iron and calcium (Eisenstadt, et al., 1973), and also produce complexing agents which selectively extract metals from dilute solution (Pollack, et al., 1970). There appear to be two mechanisms by which microbes concentrate metals: binding of metals to cell surface components and metabolism dependent intracellular accumulation (Gadd and Griffiths, 1978). Hatch and Menawat (1979) reported that the bacterium Sphaerotilus natans, found in waste sludges and polluted waters, will accumulate iron, magnesium, copper, cobalt, and cadmium in an external mucilage layer. The accumulation was a mass transfer limited process. Other physiological active cells also lead to insolubilization. Uranium (VI) was reduced by cell extracts of Micrococcus lactilyticus using hydrogen as an electron donor. The extract could also reduce molybdate to molybdenum blue and selenium to selenate (Woolfork and Whiteley, 1962). As microbes accumulate heavy metals, it is of concern whether these metals are released upon death and cellular lysis. Guthrie and Cherry (1979) found that accumulated heavy metals

increase in sediments as the organisms die, but some of the metals are returned to a system in organic detritus.

Systems utilizing bacteria or fungi have been proposed for removal of uranium from wastewater (Shumate et al., 1978; Shumate et al., 1979; Volesky and Tsezos, 1979). These processes were based upon biosorption using cell masses of the respective microbes. The fungus Rhizopus arrhizus accumulated 185 mg uranium per gram dry weight of cells (Volesky and Tsezos, 1979). A mixed culture of denitrifying bacteria decreased uranium in solution from 25 ppm to 0.5 ppm in just 8 minutes while accumulating 0.14 g uranium per gram of dry cells.

The sulfate-reducing bacteria, Desulfovibrio and Desulfotomaculum, precipitate copper and mercury from dilute solutions (Ehrlich and Fox, 1967; Ilyaletdinov et al., 1977; Temple, 1964; Temple and LeRoux, 1964; Vosjan and Van Der Hoek, 1972). Dockins et al. (1980) suggested that Desulfovibrio be used to control mining related pollution problems. It has been proposed that Desulfovibrio could be involved in deposition of uranium from solution (Jensen, 1958). The hydrogen sulfide produced by the bacteria reduces uranyl ion to uraninite. According to Taylor (1979), uranium enrichment is likely to be enhanced where reducing conditions occur in contact with water in which oxidizing conditions prevail (i.e., sediment-water interface).

The previous section presented evidence indicating a microbial consortium, algae and sulfate-reducing bacteria, was active in deposition of inorganic pollutants present in the

minewater. This section presents the bacteriological research dealing with the microbes found in the minewater and pond sediments, and their role in pollutants removal.

MATERIALS AND METHODS

Samples for microbiological analyses were collected by the "grab" method. Sterile 250-ml polypropylene bottles were used. Samples were immediately placed in an ice-chest and refrigerated upon return to the laboratory. Analyses were performed within 24 hours after sample collection.

The "total" count of microbes present was determined using the one-half strength iron peptone agar of Ferrer et al., (1963). Samples were diluted using 0.5% (w/v) peptone, and spread plates were incubated at room temperature for five days. Sulfate-reducing bacteria were enumerated using a five-tube most probable number (MPN) method with Postgate's (1966) medium E. The tubes were incubated for a period of three weeks at room temperature prior to grading. Enrichment cultures were used to demonstrate the presence of sulfur-oxidizing thiobacilli. Media numbers 125 and 290 (American Type Culture Collection, Catalog of Strains I, 13th Edition, 1978) were used for sulfur-oxidizing and thiosulfate-oxidizing thiobacilli, respectively. Growth kinetics for an isolated microbe from the algae-pond was determined using a New Brunswick Scientific Co. Bioflow, Model C30, bench-top chemostat. The medium of Ferrer et al. (1963) was used at one-half strength for the chemostat study.

Laboratory model ecosystems were set up in 2.8 l Fernbach

flasks. Each contained 1 kg of bottom sediment collected from one of the ponds at the field site, plus 1.5 l of tap water. The flasks were supplemented with sulfate, molybdate, uranium and selenium to levels approximating those in the pond system, 700 ppm, 2 ppm, 5 ppm and 25 ppb, respectively. The compounds used were Na_2SO_4 , $\text{Na}_2\text{MoO}_4 \cdot 2\text{H}_2\text{O}$, $\text{UO}_2\text{SO}_4 \cdot 3\text{H}_2\text{O}$ and selenium powder dissolved in tap water plus 1.5% (w/v) concentrated HNO_3 . Sodium lactate, 1.4 g, was added to one duplicate set of flasks to stimulate sulfate-reducing bacteria activity. One duplicate set of flasks had no further additions, and one set was autoclaved at 18 psi for 45 minutes to serve as sterile controls. The flasks were incubated at room temperature. The flasks were periodically sampled and concentrations of the respective "pollutants" determined.

RESULTS

Bacterial Populations

The "total" count of bacteria in suspension remained constant with a small decrease noted at the final discharge (Table XXIV). No pattern of variation was observed over the period of sampling.

The predominant bacterial population in algae ponds one and two were Flavobacterium with over 50% of the culturable bacteria belonging to this genus (Table XXV). A pond isolate of this genus had an optimum temperature for growth of 20 to 25°C; no growth was observed at 35°C. Chemostat culture of this microbe indicated a growth rate of 6.6 hours per division at 20°C. The microbe would only grow at pH values between 7.0 and 8.0.

The concentration of sulfate-reducing bacteria in the water

Table XXIV. Bacterial populations present
in minewater and pond sediments

Sample Site	Number bacteria ml ⁻¹	
	Total aerobic bacteria	Sulfate-reducing bacteria
Sec. 35 minewater	2.8 x 10 ⁵	3.8 x 10 ²
Sediment A-4	1.0 x 10 ^{8*}	9.2 x 10 ^{5*}
Effluent A-4	5.5 x 10 ⁵	3.6 x 10 ¹
Sec. 36 minewater	2.8 x 10 ⁵	2.7 x 10 ²
Effluent B-2	1.0 x 10 ⁵	2.3 x 10 ¹
Influent algae pond #1	3.6 x 10 ⁵	4.8 x 10 ¹
Sediment algae pond #2	1.3 x 10 ^{8*}	2.5 x 10 ^{6*}
Effluent algae pond #3	8.1 x 10 ⁴	1.1 x 10 ¹

* Number bacteria g⁻¹ dry wt.

Table XXV. Comparison of total-count of microorganisms with concentration of Flavobacterium species

Location	Total Count cells ml ⁻¹	Flavobacterium	
		cells ml ⁻¹	% of total
Algae pond #1	2.0 x 10 ⁴	1.1 x 10 ⁴	55
Algae pond #2	1.9 x 10 ⁴	1.0 x 10 ⁴	54

was greater in water coming directly from the mines (Table XXIV). Their concentration decreased as the water flowed through the treatment system. Large populations of sulfate-reducing bacteria were found in the settling pond and algae pond sediments. About 10^6 cells per gram dry-weight of sediment were observed (Table XXIV).

Enrichment cultures were positive for chemolithotrophic microbes able to oxidize sulfur at pH 5.0, thiosulfate at pH 6.6 and thiosulfate with production of gas (N_2). The respective enrichment cultures indicated presence of Thiobacillus thiooxidans, Thiobacillus thioparus, and Thiobacillus denitrificans.

Laboratory Model-Ecosystem

The effect of microbial activity on concentration of soluble sulfate, uranium, molybdenum, and selenium in the model water-sediment systems was monitored with time (Table XXVI). The data reported were average values of duplicate flasks. Three conditions were compared: a sterile control, a system which had a viable microbial flora present, and a system to which lactate was added to increase the activity of sulfate-reducing bacteria. The sulfate level was only decreased in the system containing lactate between the 48 and 120 hour sampling period. Concurrent with sulfate reduction was a decrease in concentration of soluble uranium and selenium. Molybdenum levels decreased in the lactate supplemented system and the systems without added substrate. The higher level of molybdenum in the sterile control flasks was believed to have been a result of extraction of molybdenum from the sediment during autoclaving. Selenium decreased in the sterile

Table XXVI. Decrease of selected soluble pollutants
in a sediment-water system

Time hours	Conditions	Concentration in solution			
		SO ₄ mgℓ ⁻¹ X 10 ³	U mgℓ ⁻¹	Mo mgℓ ⁻¹	Se μgℓ ⁻¹
0	sterile control	1.35	8.1	7.9	38.4
	no substance	1.27	15.5	3.2	40.7
	lactate added	1.21	9.8	2.9	59.0
24	sterile control	1.18	3.1	7.5	26.5
	no substance	1.16	13.3	3.1	31.0
	lactate added	1.29	12.1	2.8	30.0
48	sterile control	1.01	5.8	9.2	17.5
	no substance	1.14	7.5	3.1	27.0
	lactate added	1.24	8.9	3.6	14.2
120	sterile control	1.11	7.5	8.2	10
	no substance	1.18	8.2	2.5	14.5
	lactate added	0.69	3.8	2.4	<0.0
240	sterile control	1.03	7.5	6.6	14.2
	no substance	1.19	7.6	1.9	7.7
	lactate added	0.49	2.9	1.7	<0.0

control over 120 hours indicated nonbiological processes active in its removal. This experiment was repeated several times with similar results.

The variations in concentration among the different conditions were believed due to the sediment not being a homogenous mixture.

DISCUSSION

Large populations of microorganisms were found in the waters pumped from the uranium mines and water passing through the pond system (Table XXIV). It is suspected that these microbes may play a role in removal of the target elements from the water. The suspended microflora had an abundance of species of the genus Flavobacterium (Table XXV) which are widely distributed in soil and freshwater. The conditions of temperature and pH present in the algae ponds are compatible with the growth requirements of this genus. Of particular interest was the presence of the sulfate reducing bacteria, believed to be Desulfovibrio and/or Desulfotomaculum. The sulfate-reducing bacteria were relatively high in numbers in water coming directly from the mines; therefore, conditions for their growth must exist within the mining operations. These microbes decreased in number as the water progressed through the treatment system. This result was expected as Desulfovibrio and Desulfotomaculum cannot grow in aerobic conditions. However, very high numbers of these microbes were found in the pond sediments. Reducing conditions, favoring the growth of the Desulfovibrio and Desulfotomaculum, were found in the sediments as indicated by an Eh of -350 mV and black coloration a few millimeters below the sediment surface.

The laboratory experimentation indicated that the sulfate-reducing bacteria may have a role in removal of uranium, selenium, and possibly molybdenum from solution (Table XXVI). The mechanism

by which these pollutants were removed is not yet known. Sulfide production may be important since molybdenum can be precipitated as a sulfide. The reducing conditions may be responsible for converting soluble hexavalent uranium to the insoluble quadrivalent form.

Jackson (1978) reported that stimulation of microbial activity, including sulfate-reduction, by addition of nutrients from sewage was effective in removal of heavy metals from polluted mine and smelter waste-water.

Although a large population of sulfate-reducing bacteria was found in the pond sediments, there was no decrease of soluble sulfate in the water flowing through the system. Reduced forms of sulfur may be oxidized by the aerobic thiobacilli in oxidizing regions, returning the sulfur to the soluble sulfate species. The system may be nutrient limited and the activity of the sulfate-reducing bacteria quite slow.

SUMMARY

Conclusions derived from the chemical and biological studies of the Kerr-McGee Corporation uranium mine water treatment facility near Grants, New Mexico are as follows:

1. The concentrations of soluble uranium, selenium and molybdenum were not diminished in the mine waters by passage through the series of impoundments which constituted the mine water treatment facility. Uranium concentrations were reduced but this was due to passage of the water through an ion exchange column.
2. The particulate concentrations of the mine water were reduced at least ten-fold by passage of the waters through the impoundments. Since uranium, selenium and molybdenum were associated with the suspended particulates, reduction in the concentration of total suspended solids reduced the concentration of contaminants in the final effluent.
3. The ponds were well oxygenated. This was probably due to the shallow depth of the ponds and growth of algae.
4. The pH remained near neutral during all collections and this would indicate that the major soluble species of trace contaminants would be molybdate, uranyl carbonate species, selenite (and possibly selenate at the higher pH values).
5. The temperature remained higher than 10°C in winter suggesting that plant and microbial life could remain viable and that the volume of water was great enough to lessen large temperature fluctuations.

6. Phosphate and nitrate were present in high enough concentrations to support limited algal and microbial activity.
7. The sediments were anoxic and enriched in uranium, molybdenum and selenium. The deposition of particulates and the formation of insoluble compounds were proposed as mechanisms for sediment enrichment.
8. The predominant algae of the treatment ponds were the filamentous Spirogyra and Oscillatoria, and the benthic alga, Chara.
9. Adsorptive processes resulted in the accumulation of metals in the algae cells.
10. Laboratory study indicated that Spirogyra was more active than Chara in removal of uranium and molybdenum from solution.
11. The algae appeared to act as bio-filters for accumulation of particulate pollutants in the ponds.
12. The retention of uranium and molybdenum in sediments following the death and decay of the algae was dependent upon maintenance of reducing conditions.
13. The pond sediments have large numbers of the sulfate reducing bacteria Desulfovibrio and/or Desulfotomaculum.
14. Stimulation of sulfate reduction by the bacteria resulted in retention of molybdenum, selenium, and uranium in sediments.
15. Estimation of algae productivity and removal of uranium and molybdenum by the algae indicated that both stimulation

of algal productivity and increase in pond size are necessary for the system to be effective in removal of trace contaminants.

REFERENCES

- Bertine, K.K., 1972. The deposition of molybdenum in anoxic waters. *Marine Chemistry* 1: 43-53.
- Bloomfield, C., and W.I. Kelso, 1973. The mobilization and fixation of molybdenum, vanadium and uranium by decomposing plant matter. *J. Soil Sci.* 24: 368-379.
- Brandvold, L.A., 1974. Atomic absorption methods for analysis of some elements in ores and concentrates. New Mexico Bureau of Mines and Mineral Resources Circular 142, Socorro, NM.
- Brierley, J.A. and C.L. Brierley, 1980. Biological methods to remove selected inorganic pollutants from uranium mine wastewater, pp. 66. In *Biogeochemistry of ancient and modern environments*. (P.A. Trudinger, M.R. Walter and B.J. Ralph, Eds.). Elsevier, Adelaide.
- Chan, C.C.Y., 1976. Improvement in the fluorimetric determination of selenium in plant materials with 2,3-diaminonaphthalene. *Anal. Chim. Acta* 82: 213-215.
- Cotton, F.A. and G. Wilkinson, 1972. The actinide elements, pp. 1077-1104. In *Advanced Inorganic Chemistry*, Interscience Publishers, New York.
- Crawford, S.A., 1979. Farm pond restoration using Chara vulgaris vegetation. *Hydrob.* 62: 17-31.
- Dockins, W.S., G.J. Olson, G.A. McFeters, and S.C. Turbak, 1980. Dissimilatory bacterial sulfate reduction in Montana groundwaters, *Geomicro. J.* 2: 83-98.

- Ehrlich, H.L., and S.I. Fox, 1967. Copper sulfide precipitation by yeasts from acid mine-waters, *Appl. Micro.* 15: 135-139.
- Eisenstadt, E.S., S. Fisher, C.L. Der, and S. Silver, 1973. Manganese transport in Bacillus subtilis W23 during growth and sporulation. *J. Bacteriol.* 113: 1363-1372.
- EPA, March 1979. Methods for chemical analysis of water and wastes, sec. 4.1.2, p. metals-5. EPA-600/4-79-020.
- Ferguson, J. and B. Bubela, 1974. The concentration of Cu(II), PB(II) and Zn(II) from aqueous solutions by particulate algal material. *Chem Geol.* 13: 163-186.
- Ferrer, E.B., Stapert, E.M., and Sokolski, W.T., 1963. A medium for improved recovery of bacteria from water. *Canadian Journal of Microbiology*, 9: 420-422.
- Filip, D.S., T. Peters, V.D. Adams and E.J. Middlebrooks, 1979. Residual heavy-metal removal by an algae-intermittent sand filtration system. *Water Res.* 13: 305-313.
- Force, E.G., and P.L. McCarty, 1970. Anaerobic decomposition of algae. *Environ. Sci. Technol.* 4: 842-849.
- Forsberg, C., 1965. Nutritional studies of Chara in axenic culture. *Physiol. Plant.* 18: 275-290.
- Gadd, G.M., and A.J. Griffiths, 1978. Microorganisms and heavy metal toxicity, *Microbial Ecol.* 4: 303-317.
- Gale, N.L. and B.G. Wixson, 1979. Removal of heavy metals from industrial effluents by algae. *Dev. Ind. Microbiol.* 20: 259-273.
- Garrels, R.M. and C.L. Christ, 1965. Solutions, Minerals and Equilibria, pp. 253-255. Freeman, Cooper and Co., San

Francisco.

- Guthrie, R.K. and D.S. Cherry, 1979. Trophic level accumulation of heavy metals in a coal ash basin drainage system. *Water Res. Bull.* 15: 244-248.
- Gutknecht, J., 1965. Uptake and retention of cesium 137 and zinc 65 by seaweeds. *Limnol. Oceanog.* 10: 58-66.
- Hatch, R.T., and Menawat, A., 1979, Biological removal and recovery of trace heavy metals, Biotechnology and Bioengineering Symposium No. 8, pp. 191-203. John Wiley and Sons, Inc., New York.
- Hodge, V.F., M. Koide and E.D. Goldberg, 1979. Particulate uranium, plutonium and polonium in the biogeochemistries of the coastal zone. *Nature* 277: 206-209.
- Horikoshi, T., A. Nakajima and T. Sakaguchi, 1979a. Uptake of uranium by Chlorella regularis. *Agric. Biol. Chem.* 43: 617-623.
- Horikoshi, T., A. Nakajima, and T. Sakaguchi, 1979b. Uptake of uranium by various cell fractions of Chlorella regularis. *Radioisotopes* 28: 9-12.
- Hostetler, P.B., and R.N. Garrels, 1962. Transportation and precipitation of uranium and vanadium at low temperatures with special reference to sandstone-type uranium deposits. *Econ. Geol.* 57: 137-167.
- Howard, J.H. III, 1971. Geochemistry of selenium: Adsorption from natural waters. *Bull. Ga. Acad. Sci.* 29: 126 (abstract).
- Ilyaletdinov, A.N., P.B. Enker, and L.V. Loginova, 1977. Role of sulfate-reducing bacteria in the precipitation of copper.

- Microbiology, 46: 92-95.
- Jackson, K.S., I.R. Jonasson and G.B. Skippen, 1978. Nature of metals-sediment-water interactions in fresh-water bodies, with emphasis on role of organic matter. Earth-Sci. Rev. 14: 97-146.
- Jackson, T.A., 1978. The biogeochemistry of heavy metals in polluted lakes and streams at Flin Flon Canada, and a proposed method for limiting heavy-metal pollution of natural waters. Environ. Geol. 2: 173-189.
- Jarrell, A.L. Page, and A.A. Elsewi, 1980. Molybdenum in the environment. Residue Reviews 74: 1-43.
- Jennett, J.C., J.M. Hassett and J.E. Smith, 1979. Control of heavy metals in the environment using algae, pp. 210-217. In International Conf. Management and Control of Heavy Metals in the Environment, London 1979, CEP Consultants, Ltds., Edinburgh.
- Jensen, M.L., 1978. Sulfur isotopes and the origin of sandstone-type uranium deposits. Econ. Geol. 53: 598-616.
- Johnson, D.A., and T.M. Florence, 1971. Spectrophotometric determination of uranium (VI) with 2-(5-bromo-2-pyridylazo)-5-diethylaminophenol. Anal. Chim. Acta 53: 73-79.
- Justyn, J. and Z. Stanek, 1974. Accumulation of natural radionuclides in the bottom sediments and by aquatic organisms of streams. Int. Revue Ges. Hydrobiol. 59: 593-609.
- Kaback, D.S. and D.D. Runnels, 1980. Geochemistry of molybdenum in some stream sediments and waters. Geochim. Cosmochim. Acta. 44: 447-456.

Kelley, V.C. (Eds.), 1963. Geology and Technology of the Grants Uranium Region. New Mexico Bureau of Mines and Mineral Resources Memoir 15.

Kelley, D.P., P.R. Norris and C.L. Brierley, 1979. Microbiological methods for the extraction and recovery of metals, pp. 263-308. In Microbial Technology: Current State, Future Prospects. (A.T. Bull, D.C. Ellwood and C. Ratledge, Eds.). Cambridge Univ. Press, London.

Knauer, G.A. and J.H. Martin, 1973. Seasonal variations of cadmium, copper, manganese, lead and zinc in water and phytoplankton in Monterey Bay, California. Limnol. Oceanog. 18: 597-604.

Koval'skii, V.V. and I. Ye. Vorotnitskaya, 1965. Biogenic migration of uranium in Lake Issyk-kul'. Geochemistry 2: 544-551.

Lakin, H.W., 1973. Selenium in our environment, pp. 96-111. In Trace Elements in the Environment. Advances in Chem. Series 123. (E.L. Kothny, ed.) Amer. Chem. Soc., Washington, D.C.

Laube, V., S. Ramamoorthy and D.J. Kushner, 1979. Mobilization and accumulation of sediment bound heavy metals by algae. Bull. Environ. Contam. Toxicol. 21: 763-770.

Leventhal, J.S., 1980. Organic geochemistry and uranium in Grants Mineral Belt, pp. 75-85. In Geology and Mineral Technology of the Grants Uranium Region, 1979. (C.A. Rautman, Ed.). New Mexico Bureau of Mines and Mineral Resources, Memoir 38.

Lingane, J.J., 1966. Uranium (U), pp. 117-122. In Analytical

- Chemistry of Selected Metallic Elements. Reinhold Publishing Corporation, New York.
- Marchyulene, E.-D.P. 1978. Exchange of certain radionuclides between the environment and freshwater algae. *Soviet J. Ecol.* 9: 163-165.
- Mason, B., 1966. Principles of Geochemistry, 3rd Ed. John Wiley and Sons, Inc., New York.
- Measures, C.I., and J.D. Burton, 1978. Behavior and speciation of dissolved selenium in estuarine waters. *Nature* 273: 293-295.
- Meglen, R.R. and M.L. Glaze, 1973. Analytical methods. Report to the Molybdenum Project, No. MoP/g-73/MW, University of Colorado, Boulder.
- Norris, P.R., and D.P. Kelly, 1979. Accumulation of metals by bacteria and yeasts. *Dev. Ind. Micro.* 20: 299-308.
- O'Kelly, J.C., 1974. Inorganic nutrients, pp. 610-635. *In Algal Physiology and Biochemistry* (W.D.P. Stewart, Ed.). Univ. Calif. Press, Berkeley.
- Pollack, J.R., B.N. Ames, and J.B. Neilands, 1970. Iron transport in Salmonella typhimurium: mutants blocked in the biosynthesis of enterobactin. *J. Bacteriol.* 104: 635-639.
- Postgate, J.R., 1966. Media for sulphur bacteria. *Laboratory Practice* 15: 1239-1244.
- Reuter, J.H. and E.M. Perdue, 1977. Importance of heavy metal-organic matter interactions in natural waters. *Geochim. Cosmochim. Acta* 41: 325-334.

- Robinson, J.B., 1969. Sulphate influx in characean cells. I. General characteristics. *J. Exp. Bot.* 20: 201-211.
- Sandell, E.G., 1950. *Colorimetric Determination of Traces of Metals*. Interscience Publishers, New York.
- Scott, W.W., 1939. *Standard Methods of Chemical Analysis*, 5th Ed. E. Van Nostrand Co., Inc., New York.
- Shen, E.Y.F., 1971. Cultivation of Chara in defined medium, pp. 153-162. *In Contributions in Phycology*. (B.C. Parker and R.M. Brown, Jr., Eds.). Allen Press, Lawrence, Kansas.
- Shumate, S.E., G.W. Strandberg, D.A. McWhirter, J.R. Parrot, G.M. Bogacki, and B.R. Locke, 1980. Separation of heavy metals from aqueous solutions using "biosorbents"--Development of contacting devices for uranium removal. *Biotechnol. Bioeng. Symp.* 10: 27-34.
- Shumate, S.E., G.W. Strandberg and J.R. Parrott, 1978. Biological removal of metal ions from aqueous process streams, pp. 13-20. *In Biotechnology and Bioengineering Symposium No. 8*.
- Sikes, S.C., 1978. Calcification and cation sorption of Cladophora glomerata (Chlorophyta). *J. Phycol.* 14: 325-329.
- Standard Methods for the Examination of Water and Wastewater, 1971. American Public Health Association, Washington, D.C. 874 pp.
- Syers, J.K., R.F. Harris and D.E. Armstrong, 1973. Phosphate chemistry in lake sediments. *J. Env. Qual.* 2: 1-14.
- Szalay, A., 1964. Cation exchange properties of humic acids and their importance in the geochemical enrichment of UO_2^{++} and other cations. *Geochim. Cosmochim. Acta* 28: 1605-1614.
- Szalay, A., 1969. Accumulation of uranium and other trace metals

- in coal and organic shales and the role of humic acids in these geochemical enrichments. *Arkiv. Mineralogi Geologi* 5: 32-36.
- Taylor, G.H., 1979. Biogeochemistry of uranium minerals, pp. 485-514. In *Biogeochemical cycling of Mineral-Forming Elements* (P.A. Trudinger and D.J. Swaine, Eds.). Elsevier Scientific Publishing Co., Amsterdam.
- Temple, K.L., 1964. Syngensis of sulfide ores: an evaluation of biochemical aspects. *Econ. Geol.* 59: 1473-1491.
- Temple, K. L., and N.W. LeRoux, 1964. Syngensis of sulfide ores: sulfate-reducing bacteria and copper toxicity. *Econ. Geol.* 59: 271-278.
- Testing Sieves and Their Uses, 1972. Handbook 53. W.S. Tyler, Inc., Mentor, Ohio.
- Theng, B.K.G., 1971. Adsorption of molybdate by some crystalline and amorphous soil clays. *New Zeal. J. Sci.* 14: 1040-1056.
- Trudinger, P.A., D.J. Swaine and G.W. Skyring, 1979. Biogeochemical cycling of elements - general considerations, Chapt. 1. In *Biogeochemical Cycling of Mineral-Forming Elements*. (P.A. Trudinger and D.J. Swaine, Eds.). Elsevier Scientific Publishing Co., Amsterdam.
- Trudinger, P.A. and D.J. Swaine, 1979. *Biogeochemical Cycling of Mineral-Forming Elements*. Elsevier Scientific Publishing Co., Amsterdam.
- Volesky, B. and M. Tsezos, 1979. Recovery of radioactive elements from wastewaters: biosorption of uranium and thorium. Presented at the joint ACS-CSJ Conference in Honolulu, HA, April 1-6,

1979.

Vosjan, J.H., and G.J. Van Der Hook, 1972. A continuous culture of Desulfovibrio on a medium containing mercury and copper ions. Neth. J. Sea Res. 5: 440-444.

Woolfolk, C.A., and H.R. Whiteley, 1962. Reduction of inorganic compounds with molecular hydrogen by Micrococcus latilyticus. I. Stoichiometry with compounds of arsenic, selenium, tellurium, transition and others elements, J. Bacterial. 84: 647-658.

Yamamoto, T., E. Yunoki, M. Yamakawa, and M. Shimizu, 1973. Studies on environmental contamination by uranium. 3. Effects of carbonate ion on uranium adsorption to and desorption from soils. J. Radiat. Res. 14: 219-224.

Yoe, J.H., W. Fritz and R.A. Black, 1953. Colorimetric determination of uranium with dibenzoylmethane. Anal. Chem. 25: 1200-1204.

APPENDIX

THESIS

Dreher, K.T., 1980. Removal of uranium and molybdenum from uranium mine wastewaters by algae. Degree of Master of Chemistry, New Mexico Institute of Mining and Technology.

PUBLISHED PAPERS

Brierley, J.A., and C.L. Brierley. 1980. Biological methods to remove selected inorganic pollutants from uranium mine wastewater. In: P.A. Trudinger, M.R. Walter, and B.J. Ralph (eds.), Biogeochemistry of Ancient and Modern Environments. Springer-Verlag, Adelaide. pp 661-667.

Brierley, J.A., C.L. Brierley, and K.T. Dreher. 1980. Removal of selected inorganic pollutants from uranium mine wastewater by biological methods. In: C.O. Brawner (ed.), Proceedings of the First International Conference on Uranium Mine Waste Disposal. Society of Mining Engineers, New York. pp. 365-375.

PRESENTATIONS

Dreher, K., C.L. Brierley, and J.A. Brierley. Biological removal of pollutants from uranium minewaters. New Mexico Branch, American Society for Microbiology. Los Alamos, New Mexico. 1979.

Brierley, C.L., and J.A. Brierley. Biological methods to remove selected inorganic pollutants from uranium mine wastewater. Third International Symposium on Aquatic Pollutants. Jekyll Island, Georgia. 1979.

Brierley, C.L., and J.A. Brierley. Biological methods to remove selected inorganic pollutants from uranium mine wastewater. Conference on Biogeochemistry in Relation to Mining Industry and Environmental Pollution. Canberra, Australia. 1979.

Kelly, D.P., P.R. Norris and C.L. Brierley. Microbiological methods for the extraction and recovery metals. Ecology Group Symposium on Metals and Microbes at the 85th Ordinary Meeting of the Society of General Microbiology, Cambridge, England. 1979.

Brierley, J.A., C.L. Brierley, and K.T. Dreher. Removal of selected inorganic pollutants from uranium mine waste water by biological methods. First International Conference on Uranium Mine Waste Disposal. Vancouver, British Columbia. 1980.

Dreher, K.T., C.L. Brierley, and J.A. Brierley. Removal of uranium and molybdenum from uranium mine waste water by algae. Advances in Fermentation Recovery Process Technology Conference. Banff, Alberta. 1981.

LECTURES

Brierley, C.L., "Microbial Processes for Wastewater Clarification", ARCO Chemical Co., Philadelphia, Dec. 15, 1980.

Brierley, C.L., "Minerals and Microbes: Practices and Problems", Shell Research Laboratory, Sittingbourne, Kent, England, May 4, 1979.

Brierley, C.L., "Microbes and Mining: Practices and Problems", Exxon Research and Development Company, Linden, NJ, November 28, 1979.

Brierley, C.L., "Biotechnology", Atlantic Richfield Corp. Harvey Technical Center, Chicago, September 4, 1980.

Brierley, C.L., "Biological Methods for Removal of Selected Inorganic Contaminants from Uranium Mine Waters", U.S. Bureau of Mines Twin Cities Research Laboratory, St. Paul, MN, April 9, 1981.