

DISTRIBUTION SHEET

To J. R. Green G2-02	From P. D. Rittmann H6-30	Page 1 of 1
		Date Feb 14, 1995
Project Title/Work Order WHC-SD-WM-UM-030 Rev 0 ISO-PC Version 1.98 - User's Guide		EDT No. 158936
		ECN No. na

Name	MSIN	Text With All Attach.	Text Only	Attach./Appendix Only	EDT/ECN Only
B. N. Anderson	H6-30				
J. R. Green	G2-02	X			
J. Greenberg	H0-35	X			
P. D. Rittmann (5)	H6-30	X			
CENTRAL FILES (2) + orig.	L8-04	X			
OSTI (2)	L8-07	X			

RECEIVED

JUN 01 1995

OSTI

DISCLAIMER

Portions of this document may be illegible in electronic image products. Images are produced from the best available original document.

MAY 02 1995

ENGINEERING DATA TRANSMITTAL

1. EDT 158936

35 Station 21

2. To: (Receiving Organization) Packaging Engineering	3. From: (Originating Organization) Risk Assessment	4. Related EDT No.: na
5. Proj./Prog./Dept./Div.: Hanford Technical Services	6. Cog. Engr.: Paul D. Rittmann, PhD CHP	7. Purchase Order No.: na
8. Originator Remarks: Please review and approve.		9. Equip./Component No.: na
		10. System/Bldg./Facility: general
11. Receiver Remarks:		12. Major Assm. Dwg. No.: na
		13. Permit/Permit Application No.: na
		14. Required Response Date: February 14, 1995

15. DATA TRANSMITTED					(F)	(G)	(H)	(I)
(A) Item No.	(B) Document/Drawing No.	(C) Sheet No.	(D) Rev. No.	(E) Title or Description of Data Transmitted	Approval Designator	Reason for Transmittal	Originator Disposition	Receiver Disposition
1	WHC-SD-WM-UM-030		0	ISO-PC Version 1.98 - User's Guide	S Q	4/1	na	na

16. KEY			
Approval Designator (F)	Reason for Transmittal (G)		Disposition (H) & (I)
E, S, Q, D or N/A (see WHC-CM-3-5, Sec.12.7)	1. Approval 2. Release 3. Information	4. Review 5. Post-Review 6. Dist. (Receipt Acknow. Required)	1. Approved 2. Approved w/comment 3. Disapproved w/comment 4. Reviewed no/comment 5. Reviewed w/comment 6. Receipt acknowledged

17. SIGNATURE/DISTRIBUTION (See Approval Designator for required signatures)											
(G)	(H)	(J) Name	(K) Signature	(L) Date	(M) MSIN	(J) Name	(K) Signature	(L) Date	(M) MSIN	Reason	Disp.
1	1	Cog.Eng: PD Rittmann	<i>Paul Rittmann</i>	1-24-95	H6-30						
1	1	Cog.Mgr: BN Anderson	<i>BN Anderson</i>	5/1/95	H6-30						
1	1	QA: PJ Edwards	<i>PJ Edwards</i>	1/30/95	A4-79						
1	1	Safety: PR Prevost	<i>PR Prevost</i>	1/25/95	N1-72						
		Env:									
1	1	J.D. Hoover	<i>J.D. Hoover</i>	4/27/95	B4-103						

18. Paul D. Rittmann <i>Paul Rittmann</i> Signature of EDT Originator H6-30 1-24-95 Date	19. Janet R. Green <i>Janet R. Green</i> Authorized Representative for Receiving Organization G2-02 5/2/95 Date	20. J. G. Field <i>J. G. Field</i> Cooriginator Manager G2-02 4/28/95 Date	21. DOE APPROVAL (if required) Ctrl. No. [] Approved [] Approved w/comments [] Disapproved w/comments
---	--	---	--

RELEASE AUTHORIZATION

Document Number: WHC-SD-WM-UM-030, Rev. 0

Document Title: ISO-PC Version 1.98 - User's Guide

Release Date: 5/1/95

**This document was reviewed following the
procedures described in WHC-CM-3-4 and is:**

APPROVED FOR PUBLIC RELEASE

WHC Information Release Administration Specialist:

V.L. Birkland

V.L. Birkland

5/1/95

TRADEMARK DISCLAIMER. Reference herein to any specific commercial product, process, or service by trade name, trademark, manufacturer, or otherwise, does not necessarily constitute or imply its endorsement, recommendation, or favoring by the United States Government or any agency thereof or its contractors or subcontractors.

This report has been reproduced from the best available copy. Available in paper copy and microfiche. Printed in the United States of America. Available to the U.S. Department of Energy and its contractors from:

U.S. Department of Energy
Office of Scientific and Technical Information (OSTI)
P.O. Box 62
Oak Ridge, TN 37831
Telephone: (615) 576-8401

Available to the public from:

U.S. Department of Commerce
National Technical Information Service (NTIS)
5285 Port Royal Road
Springfield, VA 22161
Telephone: (703) 487-4650

DISCLAIMER

This report was prepared as an account of work sponsored by an agency of the United States Government. Neither the United States Government nor any agency thereof, nor any of their employees, makes any warranty, express or implied, or assumes any legal liability or responsibility for the accuracy, completeness, or usefulness of any information, apparatus, product, or process disclosed, or represents that its use would not infringe privately owned rights. Reference herein to any specific commercial product, process, or service by trade name, trademark, manufacturer, or otherwise does not necessarily constitute or imply its endorsement, recommendation, or favoring by the United States Government or any agency thereof. The views and opinions of authors expressed herein do not necessarily state or reflect those of the United States Government or any agency thereof.

A-6001-400.2 (09/94) WEF256

DISTRIBUTION OF THIS DOCUMENT IS UNLIMITED

MASTER
JLC

SUPPORTING DOCUMENT		1. Total Pages 94 95
2. Title ISO-PC Version 1.98 - User's Guide	3. Number WHC-SD-WM-UM-030	4. Rev No. 0
5. Key Words ISOSHL, ISO-PC, shielding, dose rate	6. Author Name: Paul D. Rittmann, PhD CHP <i>Paul Rittmann</i> Signature E39940 Organization/Charge Code OM640/E37217	
7. Abstract <p>This document describes how to use Version 1.98 of the shielding program named ISO-PC. Version 1.98 corrects all known errors in ISOSHL-II. In addition, a few numeric problems have been eliminated. There are three new namelist variables, 25 additional shielding materials, and 5 more energy groups.</p> <p>The two major differences with the original ISOSHL-II are the removal of RIBD source generator, and the removal of the non-uniform source distribution parameter, SSV1. This version of ISO-PC works with photon energies from 10 Kev to 10 Mev, using 30 energy groups.</p>		
8. RELEASE STAMP		
<div style="border: 1px solid black; padding: 10px; width: fit-content; margin: auto;"> <p>OFFICIAL RELEASE BY WHC DATE MAY 02 1995 35 Station 21</p> </div>		

ACKNOWLEDGMENTS

This document would not have been written without the encouragement of Jennie Manneschmitt at the Radiation Shielding Information Center in Oak Ridge and Jess Greenborg of Westinghouse Hanford Company. Jess provided information on data sources for the original ISOSHL, as well as the energies to use for the higher energy groups. Thanks also go to those at Westinghouse Hanford Company who discovered ways to make ISOSHL give negative answers in the sphere geometry.

This page intentionally left blank.

CONTENTS

1.0	OVERVIEW OF ISO-PC	1-1
1.1	BRIEF HISTORY OF ISOSHLD	1-1
1.2	NEW FEATURES IN ISO-PC	1-3
1.3	ERRORS CORRECTED SINCE VERSION 1.4	1-4
2.0	USING ISO-PC	2-1
2.1	INSTALLING THE PROGRAM	2-1
2.2	RUNNING THE PROGRAM	2-2
2.3	INPUT FILE ORGANIZATION	2-4
2.3.1	Run Title and MODE Selection - Line 1	2-5
2.3.2	Case Title - Line 2	2-5
2.3.3	Namelist Variables	2-5
2.3.4	Shield Material Density Lines	2-11
2.3.5	Geometry Descriptions	2-13
2.3.6	Error Messages from Improper Input	2-25
2.4	OUTPUT FILE ORGANIZATION	2-28
2.4.1	Output Header and Titles	2-28
2.4.2	Source Inventory (MODE=2)	2-28
2.4.3	Shield Composition and Attenuation Coefficients	2-28
2.4.4	Photon Production by Nuclide (OPTION=1)	2-29
2.4.5	Geometry Summary and Dose Rates	2-29
2.4.6	Input Data File Listing	2-30
2.4.7	Warning Messages	2-30
2.5	REPORTING PROBLEMS OR COMMENTS	2-31
3.0	REFERENCES	3-1
4.0	BIBLIOGRAPHY	4-1
APPENDIXES		
A	VALUES FOR MASS ATTENUATION COEFFICIENTS	A-1
B	VALUES FOR BUILDUP FACTOR COEFFICIENTS	B-1
C	VALUES FOR FLUENCE-TO DOSE CONVERSIONS	C-1
D	LISTING OF THE NUCLIDES IN THE ISO-PC LIBRARY	D-1
E	OUTPUT GENERATED BY THE SAMPLE INPUT FILE	E-1

LIST OF TABLES

2-1	Command Line Statements and Resulting Files Used by Version 1.98 . . .	2-3
2-2	Line Format for Shield Material Density Lines	2-11
2-3	Allowed Shielding Materials	2-12
2-4	Examples of Error Messages	2-26

ISO-PC VERSION 1.98 - USER'S GUIDE

1.0 OVERVIEW OF ISO-PC

This version of the computer program ISO-PC corrects all known errors in ISOSHL-D-II. In addition, a few numeric problems have been eliminated. These changes are discussed in more detail below. The two major differences with ISOSHL-D-II are the removal of the Radio-Isotope Buildup and Decay (RIBD) program, and the removal of the non-uniform source parameter, SSV1. Some new variables have been added to make it more convenient. These are also described below.

1.1 BRIEF HISTORY OF ISOSHL-D

The program originated in the 1960's and thus fully used the capabilities of computers that existed at that time. It was written in FORTRAN, the only language suitable for this task at the time. The first version of ISOSHL-D (Engle et al. 1966) used 16 energy groups ranging from 0.1 to 3.0 meV. Radioisotope data were condensed to at most six energy groups per isotope. The radioisotope source could be input by the user or computed from the RIBD program which was incorporated within the program. The RIBD program computes reactor fuel nuclide inventories for various times after irradiation. The rest of the program applied the attenuation and buildup equations to ten possible source and shield combinations. Non-uniform activity distributions were possible via the SSV1 input variable. The user was offered a choice of 18 possible shield materials, and the program obtained buildup factors from Taylor coefficients (Goldstein 1959; Rockwell 1956) for six materials (water, aluminum, iron, tin, tungsten, and lead).

The second version of ISOSHL-D was named ISOSHL-D-II (Simmons et al. 1967) and it included a calculation of bremsstrahlung for beta-emitting nuclides (Van Tuyl 1964). The same bremsstrahlung spectra are applied to all the various types of electron spectra, i.e., beta particles, positrons, and internal conversion electrons. This version expanded the shield material selection to 20. Nine photon energy groups ranging from 10 to 100 keV were added to model the bremsstrahlung photons. Dose buildup was computed by linear interpolation on tables of buildup factors rather than with Taylor coefficients. This distinction between low- and high-energy photons has been a source of errors in the program up until now. The mathematical model used in the sphere and truncated cone routines was based on the formula for Taylor buildup. Linear interpolation requires a different formula.

A third generation ISOSHL-D was named ISOSHL-D-III (Mansius 1969). It was a revision to ISOSHL-D-I (no bremsstrahlung) and changed the photon and beta particle library to allow as many energies as were needed for an isotope. There were some nuclide additions and RIBD library improvements as well.

In 1983, the buildup library was based on seven materials, with uranium being the recent addition. Two new geometries had been added: the cylinder source with cylindrical and slab shields, and the cylindrical shell source.

The isotope library contained 535 nuclides, many of which were stable isotopes needed for the RIBD program.

In 1987, a FORTRAN 77 compiler was obtained for the IBM¹ and compatible personal computers (PC) that could compile ISOSHLD-II. This compiler was manufactured by Lahey Computer Systems, Inc. The Microsoft² FORTRAN compiler marketed at this time was a subset of the 1977 FORTRAN standard, and was unable to compile ISOSHLD-II. ISOSHLD-II output formats were then modified so they would fit within 80 columns. In addition, the ICONC and SFACT variables were added to allow the user to specify source concentration and apply scale factors to the source. The RIBD was removed at this time. In the waste management activities that were analyzed by Westinghouse Hanford Company Radiological Engineering, there was no need for RIBD. When reactor inventories were needed, ORIGEN2 (Croff 1980) was used.

Grove Engineering, and others, began to market PC versions of ISOSHLD-III with various enhancements. The MICROSIELD³ program sold by Grove Engineering appears to be the most widely used of the commercial versions. The principle enhancement has been more convenient (and colorful) ways to prepare input to the program. Commercial versions of ISOSHLD-III also offer attenuation and buildup coefficients found in recent American National Standards Institute (ANSI) publications, as well as the improved photon production data from the DRALIST library (Kocher 1981).

A document that described the version of ISOSHLD-II used at the time was issued in 1989 (Lourant and Rittmann 1989). Several checks were made of the calculation of attenuation and buildup. The test cases in BNWL-236-SUP1 (Simmons et al. 1967) were run again to verify the calculations. In addition, the attenuation coefficients for lead and uranium were changed to be more compatible with other references.

In November 1993, the Radiation Shielding Information Center at Oak Ridge National Laboratory requested a copy of the Westinghouse Hanford Company version of ISOSHLD-II. Because several bugs had been noted in the ISOSHLD-II program since 1989, it was decided to correct them rather than describe them. Version 1.7 was issued the following month with the bremsstrahlung corrections. Version 1.7 also introduced the dose equivalent conversions found in ANSI/ANS-6.1.1-1991 (ANSI/ANS 1991a). The low- versus high-energy photon problems with buildup calculations were not solved until Version 1.8 was released. The present version adds 5 photon energy groups, 25 new shield materials, and other new features which are the subject of the next section. The changes are backward compatible. This means that input files for previous versions will run with the present version. Using new features in the present version will produce input files which cannot be read by earlier versions.

¹IBM is a trademark of International Business Machines Corporation.

²Microsoft is a trademark of Microsoft Corporation.

³MICROSIELD is a trademark of Grove Engineering, Inc.

1.2 NEW FEATURES IN ISO-PC

New Namelist Variable: DUNIT

This specifies fluence-to-dose-equivalent conversion factors rather than the usual exposure factors. These come from ANSI/ANS-6.1.1. The 1991 values for AP,PA,LAT,ROT, and ISO orientations are present as well as the 1977 values. To examine dose rates from all seven conversions, use DUNIT=7. Values for DUNIT are listed below:

- 0 = default output in R/h (amp/kg)
- 1 = frontal exposure (AP), output in rem/h (Sv/h)
- 2 = from rear (PA), rem/h (Sv/h)
- 3 = from side (LAT), rem/h (Sv/h)
- 4 = horizontal (ROT), rem/h (Sv/h)
- 5 = any direction (ISO), rem/h (Sv/h)
- 6 = fingers (ANSI/ANS-6.1.1-1977), rem/h (Sv/h)
- 7 = use all of the above.

Note that the JDRF variable introduced in Version 1.7 has been removed.

New Namelist Variable: X(40)

The X variable is the same as in the original ISOSHL. It is still the distance from some part of the source to the dose point. In this version it has been redefined as an array. More than one value for X can now be computed in a single case. The program will create multiple cases, one for each of the distances in the array. At most, 40 distances can be used at one time. The program senses the number of distances to use by checking the next array element for zero distance. The repetition stops when the next distance is zero.

Previous input files will run without change. The array index is only needed to tell the program change values beginning with the array element specified. For example, X(1)=100 is the same as X=100, while X(3)=50 gives input for the third array element. Note that X(3)=50,90 will change the third element to 50 cm and the fourth element to 90 cm.

New Namelist Variable: TRUNC

When using multiple distances in the truncated cone geometry (IGEOM=5), the change in distance also changes the dimensions of the source. The TRUNC variable allows the user to select other strategies. Values for TRUNC are listed below.

- 0 = default, ANGI is constant as the distance changes
- 1 = vary ANGI to keep the source volume constant
- 2 = vary ANGI to keep the face area of the source constant
- 3 = vary ANGI to keep the rear area of the source constant.

Generalized NEXT

The meaning of the NEXT variable has become simpler due to programming improvements. Both NEXT=1 and NEXT=3 mean read the lines with shield region

composition. NEXT=2 and NEXT=4 mean that these lines are not present. This simplification is possible because the program now checks for changes in the WEIGHT array. In addition, the program now stores the shield region compositions so that shield materials do not need to be reentered unless they change. In particular, changes to JBUF and ISPEC do not require repetition of the shield data.

Log-Log Interpolation

In MODE=3, when photon energies do not match the library values, the linear attenuation coefficients and fluence-to-exposure rate conversion factors are interpolated on a log-log scale. The reason for log-log rather than linear interpolation is that the data are best represented on log-log graph paper.

The interpolation of buildup factors still is done on linear coordinates because these coefficients are adequately presented on Cartesian graph paper.

Photon Energies from 10 keV to 10 meV

The original ISOSHLD-II handled photon energies between 10 keV and 3.2 meV using 25 photon groups. In Version 1.98, this was increased to 10 meV by adding the five groups with midpoint energies of 3.6, 4.5, 5.5, 6.6, and 8.6 meV. These values are used in less widely known versions of ISOSHLD (Jess Greenberg, private communication).

The mass attenuation coefficients, buildup factors, and fluence-to-dose conversion factors were evaluated from the original references (Storm et al. 1958; Rockwell 1956; Goldstein 1959) using cubic spline interpolations. These new values are shown in Appendixes A, B, and C. The soundness of the interpolation was checked using graphs of the original and interpolated parameter values. The most recent parameters for attenuation and buildup found in ANSI/ANS-6.4.3 (ANSI/ANS 1991b) have not yet been incorporated.

New Shield Materials

The shield material library has been expanded from 20 to 45 materials. This reduces the number of approximations needed to represent a specific shield mixture. The mass attenuation coefficients were taken from LA-2237 (Storm et al. 1958) to be consistent with the rest of the ISOSHLD library. The mass attenuation values are listed in Appendix A, and were computed from the values in LA-2237 using cubic spline interpolations. The interpolations did not span resonance peaks. Mass attenuation curves were treated as discontinuous at these energies.

1.3 ERRORS CORRECTED SINCE VERSION 1.4

Three bremsstrahlung errors were corrected. First, Sn, U, and Cm shields used atomic number 10 for the calculation of the bremsstrahlung spectrum. Second, IGEOM=12 computed bremsstrahlung using the first shield rather than the source, which is the second shield. Third, NEXT=3 changes to the source composition did not cause bremsstrahlung to be recomputed. All three errors have been removed.

One limitation of prior versions was that the amount of bremsstrahlung for source material atomic numbers less than 10 was all the same. The interpolation subroutine (BYIELD) has been rewritten to allow extrapolation to lower atomic numbers. Comparisons with bremsstrahlung computed using the BREMCALC program (Rittmann 1992) have shown that this extrapolation is accurate.

The calculation of low-energy buildup factors in the BFUNC function now avoids repetition, and is therefore quicker. Most geometries show a 30% decrease in execution time.

For the truncated cone and the spheres (IGEOM= 3, 4, and 5), the low-energy group buildup factors were computed by extrapolating the Taylor coefficients from higher energies. The low-energy buildup factors are now used correctly in these geometries.

Numeric errors, which resulted from the difference between two numbers that are nearly the same, were fairly common in the truncated cone geometry (IGEOM=5) and were possible in the sphere geometries (IGEOM= 3 and 4). The functions used to compute the exact integral have been replaced with new functions with relative errors less than $1E-5$ for all values of input. Note that ISO-PC still works in single precision (32 bit reals).

This page intentionally left blank.

2.0 USING ISO-PC

2.1 INSTALLING THE PROGRAM

The ISO-PC Version 1.98 distribution diskette contains the archive files ISO-19.ZOO, ISO-19D.ZOO, ISO-19F.ZOO, and ISO-19T.ZOO. The ZOO.EXE archive utility and its documentation are public domain, and are included on the diskette. In addition, a batch file (INSTALL.BAT) on the floppy disk will install ISO-PC into any subdirectory on the target hard disk. This batch file will also run two test cases and compare the results with the verified output.

Summary of Files on the Distribution Diskette

ISO-19.ZOO:

- ISO-PC.EXE = Executable (needs 80386+80387 or higher central processing unit [CPU])
- ISO-286.EXE = Executable which runs on an 80286 CPU
- ISO-PC.LIB = Library of attenuation coefficients, buildup factors, and photon and beta particle energies
- F77L.EER = Error message file from Lahey Computer Systems¹
- README.19 = Short list of new features in Version 1.98
- SUMMARY.19 = Brief summary of the program
- ISO-NUC.LST = Lists of nuclides currently in the library
- RI.BAT = Batch file which accepts up to nine input files at once. This one assumes the input files have no file name extension. Output files are named X.ISO, where X is the name of the input file.
- RI2.BAT = Run file which assumes the input files all have the file name extension ".IN". Output files all have the extension ".OUT".

ISO-19D.ZOO:

- ISO-PC.W19 = Guide for users (this document)
- SUMMARY.W19 and README.W19 = WordPerfect² version of the SUMMARY.19 and README.19 text files

ISO-19F.ZOO:

- ISO-PC.FOR = Nearly all of the FORTRAN code
- ISO-MISC.FOR = Subroutines which do not use common blocks
- BLOCK.FOR = Block data subroutine only
- BLANK.CMN = Blank common variables included in many subroutines
- BREMS.CMN = Beta and bremsstrahlung variables used in a few subroutines

ISO-19T.ZOO:

- TST-?? = Test case input files for validation against the ISOSHLD-II documentation (BNWL-236 SUP1)
- TST-??..19 = Test case output files for validation against the ISOSHLD-II documentation (BNWL-236 SUP1)

¹F77L and Lahey are trademarks of Lahey Computer Systems, Inc.

²WordPerfect is a trademark of WordPerfect Corporation.

TST-?.19S = Test case summary result files for validation against the ISOSHLD-II documentation (BNWL-236 SUP1)
CSSR.* = Another sample case (55-gal drum)
TEST\$1 & 2 = Test cases used when installing ISO-PC to verify that ISO-PC works correctly on the computer.

To install ISO-PC on the hard disk, first create a subdirectory for the ISO-PC files on the hard disk. A new subdirectory keeps the files in one place for convenient access. If there already is a previous version of ISO-PC on the disk, do not put the new version in the same location. The layout of the numbers inside the main data file, ISO-PC.LIB, has changed. The new library file cannot be read by prior versions of ISO-PC. If the old program will never be used again, use the existing subdirectory.

The second step is to change to the subdirectory where ISO-PC will be installed. The DOS command to change directories is CHDIR or CD. The final step is to start the installation batch file with the command (in DOS):

A:INSTALL A:

where the drive letter (A:) refers to the floppy drive with the installation diskette. If the installation diskette is in a different drive, use that drive letter instead. The installation batch file will ask you to confirm that the current hard disk subdirectory is where the program should be installed.

As with previous versions of ISO-PC, it is assumed that the ANSI.SYS driver that comes with DOS has been installed prior to executing the program. Commands for ANSI.SYS are used to add color and to clear the video screen. The ANSI.SYS file comes with the DOS, and is installed when the computer "boots up" by having a line in the CONFIG.SYS file that reads "DEVICE=ANSI.SYS". This PC version of ISOSHLD will run without the ANSI.SYS driver; however, odd-looking character strings will appear at the beginning of some lines.

2.2 RUNNING THE PROGRAM

Input to the program is provided in ASCII text files with the special format described below. Assuming that such files are available to the user, the following discussion shows how to use ISO-PC to convert the input parameters into output dose rates.

This version of ISO-PC can be run in either interactive or batch mode. The interactive mode asks the user to type in the name of the input and output files. The batch mode speeds the start of execution by accepting the file names on the command line. In addition, batch mode allows the running of multiple input files using a batch program, such as RI.BAT, which is supplied on the ISO-PC distribution diskette.

Interactive mode is essentially the same as before. Type in the name of the program, ISO-PC, to start it running. When the program requests the name of the input file, it assumes the file name has a .IN extension, unless a

period is included in the file name. For example, if you type the word "DRUM", the program looks for a file named DRUM.IN. But if you enter the word "DRUM." the program looks for DRUM. Similarly, when the program requests the name of an output file, it (by default) assumes the output file will have the same name as the input file except for a .OUT extension. The user does not need to type the name of an output file. Press "Enter" when the program asks for the file name, and the default will be used. If a file name with no period is typed in, a .OUT will be added to the name. If the new name has a period, the .OUT will not be used. In all cases, the name of the summary file is taken from the name of the output file. The first part of the name is the same as the output file. The extension is changed from .OUT to .SUM for the summary file.

Batch mode means the program runs without stopping to ask the name of the input and output files. Batch mode is convenient when using multiple input files. To run ISO-PC in batch mode, type the names of the input and output files on the command line, immediately after the name of the program. Note that the name of the output file is optional because the program default is the input file name with a .OUT extension. Examples of possible command line statements and the resulting combination of input and output files are shown in Table 2-1. Note that a summary file with just the dose results is created automatically from the output file name. This summary file is convenient for creating tables in spreadsheets or reports.

If the program cannot locate the input file on the disk, it will display the usual prompt requesting the name of an input file. To end program execution at this point, press the Ctrl-C combination. This prompt will appear even in batch mode because the program cannot run without an input file.

If the program detects that the output file already exists on the disk, it will ask the user whether to overwrite it. If the user does not want to overwrite it (presses anything but "Y"), the program will ask for the name of the output file again. This prompt does not appear in batch mode. In batch mode, the file is automatically replaced, if it exists.

Table 2-1. Command Line Statements and Resulting Files
Used by Version 1.98.

DOS command	Input file	Output file	Summary file
ISO-PC drum	drum.in	drum.out	drum.sum
ISO-PC drum.	drum.	drum.out	drum.sum
ISO-PC drum test	drum.in	test.out	test.sum
ISO-PC drum. wall.iso	drum.	wall.iso	wall.sum

NOTE: Drive letters and subdirectory names may precede the file names.

A third file used by ISO-PC is the library file containing shielding data and photon and beta particle production data for 535 nuclides. If the library

file (named "ISO-PC.LIB") is not in the default directory, the program will ask for the name of the library file. This request will appear even in batch mode because the program cannot run without this data file. The input, output, and library files do not need to be on the default drive or directory. The drive and/or path can be specified as part of the file name.

The way the program chooses whether to add the default extension is by the presence of a period in the file name. If there is a period, the file name is used as is. If there is no period, the default extension is assumed. The name of the summary file is always taken from the output file name.

2.3 INPUT FILE ORGANIZATION

An input file is a text file with a required sequence of data. Sample input files are included with the program to illustrate how such files are organized. It is often simpler to revise an existing file than to create a new one. The required data sequence is described in the following sections. The example discussed in this section will calculate exposure rates near a 55-gal drum filled with little contaminated waste (2 kg source mass) or soil (303 kg). The radionuclide source is 7 Ci of ⁹⁰Sr and 1 Ci of ¹³⁷Cs. The dose points are at 2 in. and 3 ft from the side of the drum.

Example MODE=2 Input File

```
0      2 Standard 55 gallon Drum with Cs & Sr Contaminated Waste
Low Density Source, 3 ft Away
&Input Next=1,
  IGeom= 8, SLTH= 82, Y= 41, T(1)= 28, 0.16, X= 119.6,
  NShld= 2, JBuf= 1, NTheta= 9, NPsi= 11, Delr= 2.0, Option= 1,
  Weight(82)= 7, Weight(84)= 7, Weight(335)= 1, 0.946 &
  misc 2 0.01
1 iron 9 7.86
Low Density Source, Contact (2 inches)
&Input Next= 4, x= 33.24 &
Soil-Filled Drum, Contact (2 in)
&Input Next= 3, SFact= 0.1 &
  conc 16 1.5
1 iron 9 7.86
Soil Filled Drum, 3 ft Away
*****> this second line will be ignored
&Input Next= 4, X= 119.6 &
This is the End of the Drum Case !!
&Input Next= 6 &
```

The factor 0.1 in the third case checks the use of SFact in the Option=1 tables.

2.3.1 Run Title and MODE Selection - Line 1

The first line of the input file contains the title of the run and values for two parameters, MODE and IPRNT. The run title may be as long as 78 characters. It provides a one-line summary of what is computed in this input file. Additional comments may be added at the end of the input file because reading stops at the last case.

The value for MODE specifies the source for the photons. MODE=1 uses the RIBD subprogram to compute fission product inventories based on a specified fuel history. Up to five cooling times could be specified. Because RIBD has been removed, entering this value ends the run with a reminder not to use this value. MODE=2 uses the photon library and user-specified activity concentrations ($\mu\text{Ci/cc}$) or total activity (curies) for up to 535 nuclides. MODE=3 requires the user to give values for photon energies and source production rates. This is one way to reduce execution time for photon sources which have only a few groups that give all the doses.

The value of IPRNT specifies the level of detail presented in the output file. The value of 0 leads to tables showing various output results by photon energy group. Any other value causes ISO-PC to skip these output tables. The value given IPRNT may be changed with each new case because IPRNT is also a namelist variable.

As shown earlier, the required format for the first line of the file is two integers at the beginning of the line followed by the run title. The first integer is IPRNT. The second integer is MODE. There must be nine blank spaces between these two integers. The run title can be placed anywhere on the line after these integers.

2.3.2 Case Title - Line 2

Each case will generate one dose result unless the new multiple distance option is being used. On the second line of the input file is the title of the first case to be run. Up to 78 characters are allowed. During the computer run, the case titles are printed on the screen as well as in the output file. Case titles are also used to identify the dose rates written to the summary file.

2.3.3 Namelist Variables

The lines containing the namelist input values follow each case title. The namelist values begin and end with the character "&". The program searches for the letter "&INPUT" to mark the beginning of the namelist input. The word "INPUT" after the first "&" identifies the group of namelist variables between the "&" signs. Note that both upper and lowercase letters are acceptable. In the descriptions that follow, the namelist variables are identified in upper case only. The mixture of upper and lowercase letters in the above example input file is simply a preference of the present author.

Namelist variables are assigned values as shown in the example. The namelist variable is written out, followed by an equal sign, and finally by the value to be assigned to the variable. Namelist variables can be in any order. Commas separate namelist items. Blank spaces between variables and values are optional, and are inserted for clarity only.

Not all namelist variables need to be specified in each case. The namelist variables have default values. The program assigns initial values to each namelist variable. If the user does not assign a new value, the default value remains. In addition, in later cases, the namelist variables that do not change do not need to be reassigned. In the example input, the only variable that changes going from the first case to the second is the control variable (NEXT) and the distance (X).

All the namelist variables that ISO-PC accepts are described below along with the default values that each is initially assigned. The namelist variables are divided into five categories: (1) program control, (2) source definition, (3) geometry, (4) shielding, and (5) integration. Each category is discussed separately.

2.3.3.1 Program Control Variables: NEXT, IPRNT, OPTION, ISPEC, and DUNIT.

The NEXT variable controls the type of input the program will expect for this case. Acceptable values for NEXT are described below. If the value for NEXT is <1 or >6, the program resets the value to either 1 or 6.

NEXT < 1 ISO-PC responds to this unusual input by changing NEXT to equal 1. The program then proceeds as shown for NEXT=1.

NEXT = 1 Tries to read new shield material data immediately after the
or namelist. If the lines are missing, a compiler-generated error
NEXT = 3 message will be displayed due to invalid numeric data. This value
of NEXT is the program default. It is required for the first case
and any case following a NEXT=5.

NEXT = 2 No shield region composition lines will be read. Any lines that
NEXT = 4 may be present will be treated as part of the subsequent case.

NEXT = 5 Resets all namelist variables to their initial default values. No
calculations are carried out. All isotopic information is zeroed.
A complete set of namelist variables and shield region compositions
must be specified in the case that follows this one.

NEXT = 6 Ends the ISO-PC run. No calculations are performed. The program
exits the CONTRL subroutine normally, and copies the input file into
the output file for future reference. A case with NEXT=6 is only
needed if the user wishes to append comment lines to the input file.

NEXT > 6 ISO-PC responds to this unusual input by changing NEXT to equal 6.
The program then ends normally.

The other variables (IPRNT, OPTION, ISPEC, and DUNIT) control different aspects of the output file. Each operates independently of the other.

The value of IPRNT specifies the level of detail presented in the output file. The value of 0 produces tables showing various output results by photon energy group. Any other value for IPRNT will cause ISO-PC to skip these tables in the output. Because IPRNT is one of the two initialization variables on the first line of input, there is no default value.

The value of OPTION determines whether tables showing the photon source strength by radionuclide are placed in the output file. These tables are created after the WEIGHT values are read and when new bremsstrahlung values are computed. The value of 1 produces the extra tables. The default is zero, which prevents these tables from appearing. The tables show how much each nuclide contributes to the final photon spectrum. Each nuclide spectrum is weighted by the amount present in the source. The bremsstrahlung contribution is also included. OPTION=1 also generates a table of fluence-to-dose conversion factors if DUNIT=7. These factors can be generated under either value for the MODE variable.

The value of ISPEC is used to select gamma or bremsstrahlung or both for the photon spectrum. This input is only used if MODE=2. If ISPEC is <1, ISPEC is changed to 1. If ISPEC is >3, ISPEC is changed to 3.

ISPEC = 1 Gammas are used for the photon spectrum, but bremsstrahlung photons are not. If the bremsstrahlung from the source will contribute little to the final answer, this will reduce the run time by reducing the number of photon energy groups.

ISPEC = 2 Bremsstrahlung photons are used for the photon source, but gammas are not.

ISPEC = 3 Both gamma and bremsstrahlung photons are used. This is the default value for ISPEC if no value is entered.

The value of DUNIT controls which of the fluence-to-dose-equivalent conversion factors are used for the dose calculations. These come from ANSI/ANS-6.1.1. The 1991 values for AP,PA,LAT,ROT, and ISO orientations are present as well as the 1977 values. To examine dose rates from all seven conversions, use DUNIT=7. If DUNIT is less than 0, DUNIT is changed to 0. If DUNIT is greater than 7, DUNIT is changed to 7. Values for the fluence-to-dose conversions are listed in Appendix C. Normal values for DUNIT are listed below.

DUNIT = 0 Use the default fluence-to-exposure rate conversions that were issued with ISOSHLD-II. Output is in R/h (amp/kg).

DUNIT = 1 Use the fluence-to-dose conversions for radiation that enters the body from the front. This is called the anterior-posterior (AP) orientation in ANSI/ANS-6.1.1-1991. Output is in rem/h (Sv/h).

DUNIT = 2 Use the fluence-to-dose conversions for radiation that enters the body from the rear. This is called the posterior-anterior (PA) orientation in ANSI/ANS-6.1.1-1991. Output is in rem/h (Sv/h).

- DUNIT = 3 Use the fluence-to-dose conversions for radiation that enters the body from the side. This is called the lateral (LAT) orientation in ANSI/ANS-6.1.1-1991. Output is in rem/h (Sv/h).
- DUNIT = 4 Use the fluence-to-dose conversions for radiation that enters a standing body horizontally from any direction. This is called the rotationally symmetric (ROT) orientation in ANSI/ANS-6.1.1-1991. Output is in rem/h (Sv/h).
- DUNIT = 5 Use the fluence-to-dose conversions for radiation that enters the body from any direction. This is called the isomorphic (ISO) orientation in ANSI/ANS-6.1.1-1991. Output is in rem/h (Sv/h).
- DUNIT = 6 Use the fluence-to-dose conversions for radiation that enters a homogenized body according to ANSI/ANS-6.1.1-1977. Output is in rem/h (Sv/h).
- DUNIT = 7 Use all the above fluence-to-dose conversion factors. If OPTION=1 a table of fluence-to-dose conversion factors is also printed along with a table of doses.

The dose rate table generated when IPRNT=0 includes a column for the fluence-to-dose conversion factor for that energy group. When DUNIT=7, the dose rate table is the same as for DUNIT=0, and an extra table lists the dose equivalent rates for the other DUNIT choices.

2.3.3.2 Source Definition Variables: WEIGHT, SOURCE, ICONC, SFACT, and SSV1. The WEIGHT variable identifies specific isotopes. WEIGHT is an array of 550 real values. Source inventory is entered by giving a specific WEIGHT array element a value, as shown in the example input file. WEIGHT(K) is the amount of nuclide number K that is present in the source. To find the array index (K) of specific nuclides, use the library listing in Appendix D. The default values for WEIGHT are all zero in MODE=2. Values for WEIGHT in the namelist are required in MODE=2 only. The first 31 array elements may be used as energy group scale factors in MODE=3. In MODE=3, the default value for the first 31 array elements is 1. Note that short-lived radioactive daughter nuclides must be included by the user. In the example input, the user has selected 1.0 Ci of ¹³⁷Cs (WEIGHT(335) = 1.0), which has a short-lived daughter named ^{137m}Ba (WEIGHT(336) = 0.946) that is in radioactive equilibrium.

WARNING: ISO-PC **DOES NOT** add the daughters of the isotopes into the calculations automatically. These radioactive progeny nuclides **MUST** be included by the user for accurate calculations.

In MODE=2, the WEIGHT variable can be changed without consideration of the value for NEXT. The current version of ISO-PC now detects changes in WEIGHT, and performs the necessary computations.

The SOURCE variable is used when MODE=3 to specify the photon energy and photon production rate. SOURCE is a two-dimensional array that requires care in the namelist input to ensure that the array is read in the proper order. The first index has the values 1, 2, or 3, which are explained below. The second index ranges from 1 to 30, corresponding to the 30 possible energy groups.

SOURCE(1,K) = The number of photons per second emitted from the source for energy group K.

SOURCE(2,K) = The midpoint energy of the Kth photon group.

SOURCE(3,K) = The energy flux at the dose point, in meV per second per square centimeter.

For example, 1 Ci of ^{137}Cs along with 0.946 Ci of $^{137\text{m}}\text{Ba}$ could be specified in MODE=3 using two photon energy groups. The first group is at an energy of 0.037 meV, and produces $1.40\text{E}+03$ photons/s. The second group is at 0.662 meV, and produces $3.115\text{E}+10$ photons/s. The corresponding namelist input is shown below:

```
SOURCE(1,1)= 1.400E+03, 0.037, 0.0,  
SOURCE(1,2)= 3.115E+10, 0.662, 0.0,
```

Notice that the group number is identified by the second array index. The photon production rate, group energy, and energy flux must be in the order shown. The program determines the number of photon energy groups by looking for the first group with zero photons per second. Therefore, do not skip any array indices, or the group count will be less than the input suggests.

In MODE=3, the first 31 elements of the WEIGHT variable may be used as scale factors on the photon production rates for the corresponding photon energy groups. WEIGHT(31) is a factor applied to all photon groups. The default value for these scale factors is 1. In MODE=3, the WEIGHT scale factors and the SOURCE photons may be changed anytime. If the SOURCE(2,K) group energies are changed, the attenuation coefficients and buildup factors are recomputed according to the new group energies.

When MODE=2, any input for SOURCE is ignored. The SOURCE array is used internally to store the computed photon spectrum.

The variable ICONC tells the program whether to interpret the source as the total activity in the selected geometry (ICONC=0), or to interpret the initial source as a concentration (ICONC=1). The default value is zero. For example, with ICONC=1 the line source has concentration units of microcuries per centimeter of length ($\mu\text{Ci}/\text{cm}$), while a disc source has concentration units of microcuries per square centimeter ($\mu\text{Ci}/\text{cm}^2$). The remaining sources have units of microcuries per cubic centimeter ($\mu\text{Ci}/\text{cc}$). Note that when MODE=3, the units are photons per second per unit length, area, or volume. The conversion from curies to microcuries only takes place when MODE=2.

The variable SFACT is a scale factor that is multiplied by each photon group to adjust the overall source inventory. The default value is 1. SFACT is convenient when units other than $\mu\text{Ci}/\text{cc}$ will be used with ICONC=1. For example, given a concentration in curies per gallon, set the weight values equal to the given concentrations and set SFACT=264.17 to convert Ci/gal to $\mu\text{Ci}/\text{cc}$.

As a final note, the source activity must be uniformly distributed through the source volume. Any input value for the variable SSV1 will be ignored. If a non-zero value for SSV1 is present in the namelist, a message

will be placed in the output file to remind the user that SSV1 is no longer used in the calculations.

2.3.3.3 Geometry Variables: IGEOM, ANG1, ANG2, T, X, Y, SLTH, and TRUNC. The IGEOM variable selects the geometrical shape of the source and shields. IGEOM can be changed for any value of NEXT.

IGEOM = 1	Point source - Slab shields
IGEOM = 2	Line source - Slab shields
IGEOM = 3	Spherical source - Spherical shields
IGEOM = 4	Spherical source - Slab shields
IGEOM = 5	Truncated cone source - Slab shields Infinite Slab and Plane source - Slab shields
IGEOM = 6	Disc source - Slab shields (Detector on centerline)
IGEOM = 7	Cylindrical source - Cylindrical shields
IGEOM = 8	Cylindrical source - Slab shields
IGEOM = 9	End of Cylinder - Slab shields (Detector on centerline)
IGEOM = 10	Rectangular source - Slab shields (Detector on centerline)
IGEOM = 11	Cylindrical source - Cylindrical and slab shields
IGEOM = 12	Annular cylindrical source - Cylindrical and slab shields.

Each of these geometries is described in detail in Section 2.3.5.

2.3.3.4 Shielding Variables: NSHLD and JBUF. The variable NSHLD tells the program how many shields will be used in this problem. A maximum of five user-defined shields is permitted. The program automatically inserts air to fill the empty space between the shields and the detection point. For the annular cylinder (IGEOM=12) NSHLD cannot be 1 or 2 because the third shield region lies within the source. Three shield regions must be specified. For all other geometries, at least one region must be specified.

The variable JBUF instructs the program which shield region should be used in computing the buildup factor. If no value is entered, JBUF is automatically set equal to NSHLD. The common shielding convention is to assign JBUF to the outermost shield (i.e., closest to the detector) that has at least one relaxation length of material for the energy groups giving the majority of the dose rate. A relaxation length is the inverse of the linear attenuation coefficient. If the outermost shield is not thick enough, the thickest shield (in terms of relaxation lengths) should be chosen for the buildup factor. The computed attenuation coefficients are listed in the printed output under the input shield materials if IPRNT=0.

The densities of the various components of each shield are given on lines immediately following the namelist lines. These are described in Section 2.3.4. The NSHLD variable can only be changed if NEXT is 1 or 3, and all the density data must be entered again at that time.

2.3.3.5 Numeric Integration Variables: NTHETA, NPSI, and DELR. The integration variables determine how many intervals into which to slice the source. DELR is the thickness of the chunks, in centimeters. Not all geometries need integration specifications. Check the descriptions in Section 2.3.5 for details.

The optimum choices for these variables depend on the distance from the source and the geometry. Choosing NTHETA and NPSI to give chunks that are no larger than the distance from the face of the source is best. DELR should be no more than one relaxation length in the source material. When the detector is close to the source, DELR should be smaller than a relaxation length.

2.3.4 Shield Material Density Lines

The shield composition lines follow the namelist lines in the input file. There is one line for each shield material. Each line has values for the density (in grams per cubic centimeter) of that material in each shield region. A shield may consist of several materials such as an alloy or homogeneous mixture of a chemical compound. There is no limit on the number of lines of shield components that may be used. The only limit is on the number of shield regions, namely five.

The required format is shown in Table 2-2. Notice that zero values do not need to be written because the blank spaces will be read as zeros. For alloys or homogenous mixtures of materials, use the density of the material as it is found in that shield (Table 2-3). This partial density is the product of the bulk density of the material and the fraction of the weight contributed by the component.

Table 2-2. Line Format for Shield Material Density Lines.

Column	Format	What is needed
1	I1	Blank (or zero) on every line except the last one, which must have a "1".
2-8	----	Write what you want, the information is ignored.
9-10	I1	Library identification number for this material (see list below).
11-20	E10.4	grams/cc of this material in Shield 1
21-30	E10.4	grams/cc of this material in Shield 2
31-40	E10.4	grams/cc of this material in Shield 3
41-50	E10.4	grams/cc of this material in Shield 4
51-60	E10.4	grams/cc of this material in Shield 5

Table 2-3. Allowed Shielding Materials.

Library number	Material	Density (g/cc)	Atomic number	Atomic weight	Bremsstrahlung atomic number
1	Water	1.0	3.333	6.005	6.60
2	Tissue	1.0	3.445	6.277	6.568
3	Air	0.00129	7.262	14.548	7.360
16	Ordinary conc	2.35	9.389	18.767	11.496
21	Hanford soil	1.67	10.78	21.83	12.66
17	Magnetite conc	3.76	11.811	24.404	18.532
4	Hydrogen	0.000089	1	1.0079	1
5	Lithium	0.532	3	6.941	3
6	Carbon	2.62	6	12.011	6
22	Nitrogen	0.00125	7	14.007	7
23	Oxygen	0.00143	8	15.999	8
24	Fluorine	0.00170	9	18.998	9
25	Sodium	0.97	11	22.990	11
26	Magnesium	1.74	12	24.305	12
7	Aluminum	2.70	13	26.982	13
27	Silicon	2.33	14	28.086	14
28	Phosphorus	1.82	15	30.974	15
29	Sulfur	2.07	16	32.066	16
30	Chlorine	0.00317	17	35.453	17
31	Argon	0.00178	18	39.948	18
32	Potassium	0.86	19	39.098	19
33	Calcium	1.55	20	40.078	20
8	Titanium	4.50	22	47.88	22
34	Chromium	7.19	24	51.996	24
9	Iron	7.86	26	55.847	26
10	Nickel	8.90	28	58.69	28
35	Zinc	7.14	30	65.39	30
36	Arsenic	5.72	33	74.922	33
18	Strontium	2.6	38	90.0	38
11	Zirconium	6.49	40	91.224	40
37	Rhodium	12.4	45	102.91	45
38	Silver	10.5	47	107.87	47
12	Tin	7.30	50	118.71	50
39	Cesium	1.87	55	137.0	55
19	Promethium	6.5	61	147.0	61
40	Erbium	9.05	68	167.26	68
13	Tungsten	19.3	74	183.85	74
41	Iridium	22.5	77	192.22	77
42	Gold	19.3	79	196.97	79
14	Lead	11.35	82	207.2	82
43	Radium	5.0	88	226.0	88
44	Thorium	11.7	90	232.04	90
15	Uranium	18.90	92	238.0	92
45	Plutonium	19.8	94	239.0	94
20	Curium	13.5	96	245.0	96

Note that there are now 45 materials. All but one of the added shield materials are pure elements. The other (#21) is a mixture that represents Hanford Site sand and gravel in the dry state (Brown 1991). To include typical soil moisture, include water (#1) with a density of about 0.1 g/cc.

2.3.5 Geometry Descriptions

Each of the geometries is described in detail below. The input parameters required for each geometry are given along with information on how the numeric integration takes place. All distances are in centimeters; all angles are in degrees. The dose point is not allowed to be inside the source or any of the shields, except the last one. If the dimensions given by the user will place the dose point inside one of the shields, ISO-PC will adjust the outer shield thickness to put the detection point outside. The user must examine the output carefully to spot unintended changes of this type. A warning message is written on the screen and also placed in the output file. Up to five shields may be specified for each geometry. The source region (T(1) for all except IGEOM=12) must be specified as a minimum. For IGEOM=12, at least three shield regions must be specified.

2.3.5.1 Point Source - Slab Shields (IGEOM = 1).

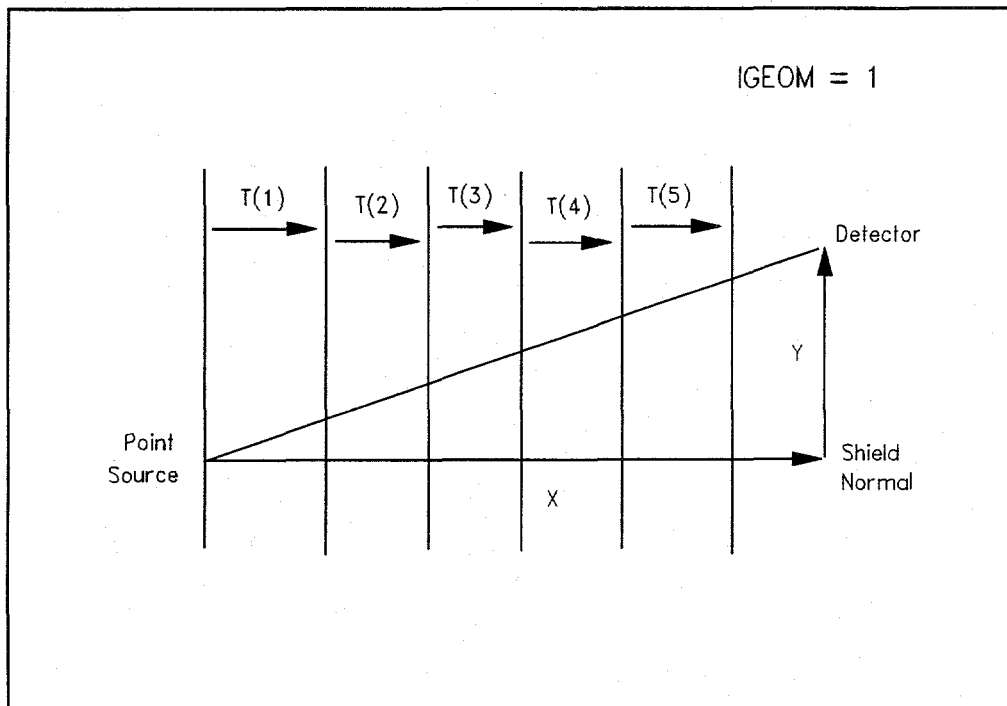

Input Variables:

T(1) = Thickness of first shield. The composition of the first shield determines the amount of bremsstrahlung computed for beta emitters (if ISPEC is 2 or 3).

T(2)..T(5) = Thicknesses of the remaining slabs

X = Distance from the source point measured normal to the shields. With Version 1.8 this became an array of 40 elements to allow multiple distance cases.

Y = Perpendicular offset distance

2.3.5.2 Line Source - Slab Shields (IGEOM = 2).

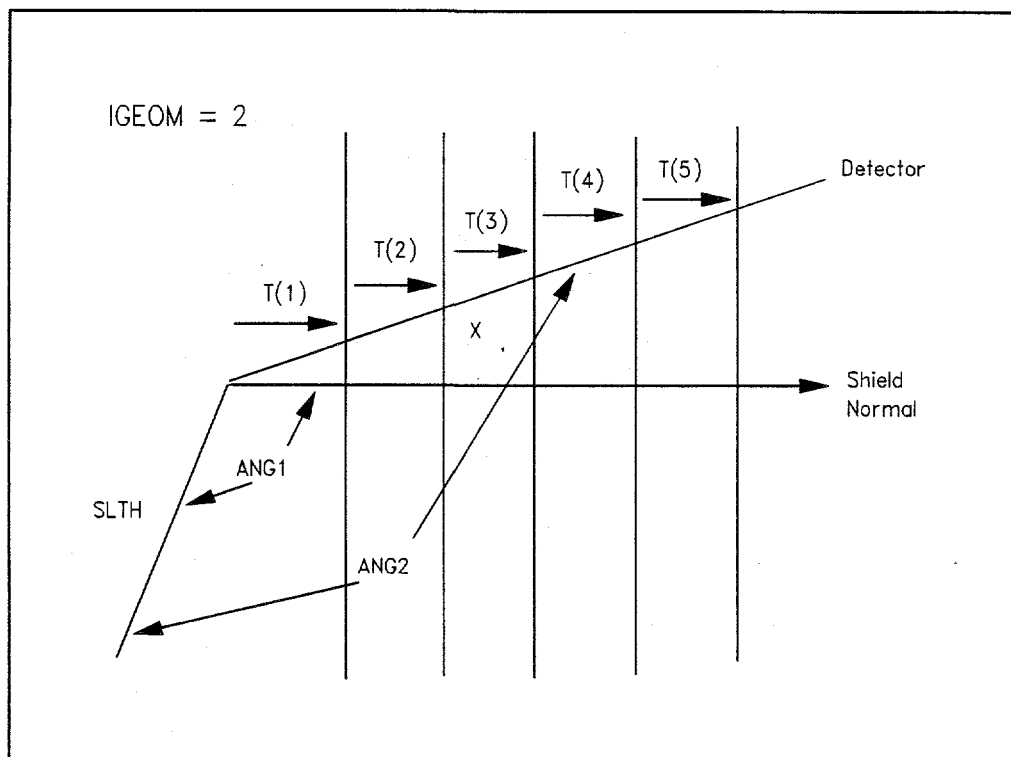

Input Variables:

$SLTH$ = Length of the line source

$T(1)$ = Thickness of first shield. The composition of the first shield determines the amount of bremsstrahlung computed for beta emitters. Notice that the first shield fills the space between the line and the second shield. The thickness of this shield may be increased by the program so the source will lie within the first shield. A warning message is given if this happens.

$T(2)..T(5)$ = Thicknesses of the remaining slabs

$ANG1$ = Angle between the shield normal and the line source, 0° to 180°

$ANG2$ = Angle between the line source and the dose point. The allowed range is $(ANG1 - 90^\circ)$ to $(ANG1 + 90^\circ)$.

X = Distance from the end of the line source to the dose point. With Version 1.8 this became an array of 40 elements to allow multiple distance cases.

NOTE: The line, the detection point, and the shield normal all lie in the same plane, making this a two-dimensional arrangement.

2.3.5.3 Spherical Source - Spherical Shields (IGEOM = 3).

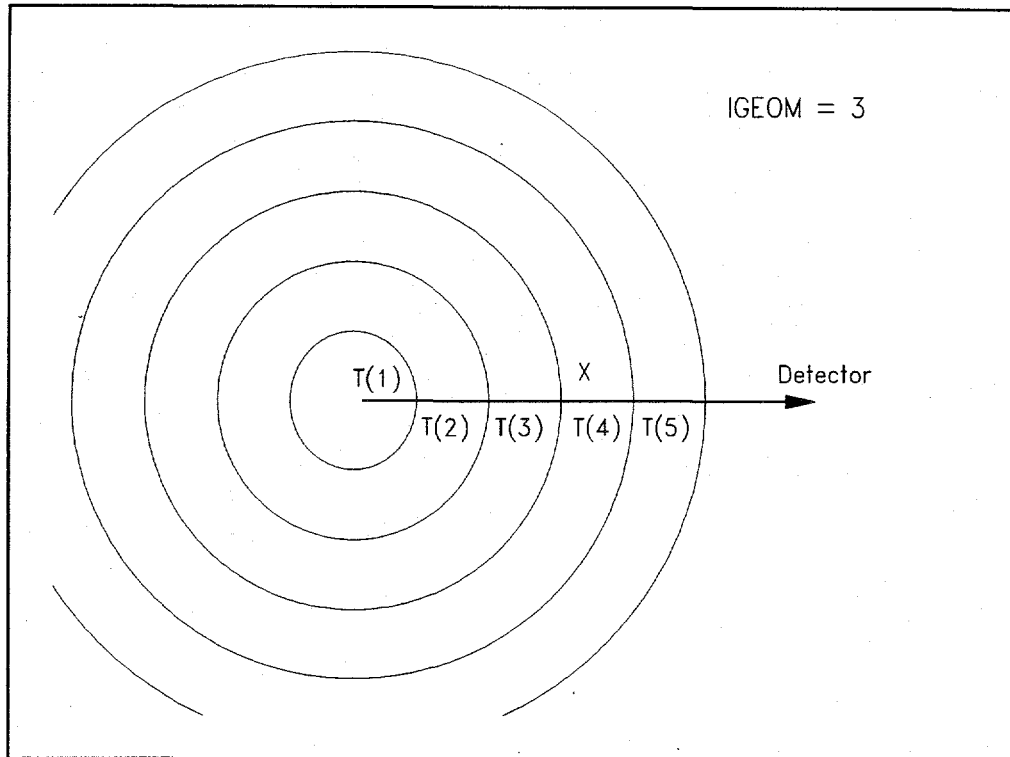

Input Variables:

X = Distance from center of sphere to the dose point. With Version 1.8 this became an array of 40 elements to allow multiple distance cases.

T(1) = Radius of the source region, a sphere

T(2)..T(5) = Thicknesses of the remaining shields (spherical).

2.3.5.4 Spherical Source - Slab Shields (IGEOM = 4).

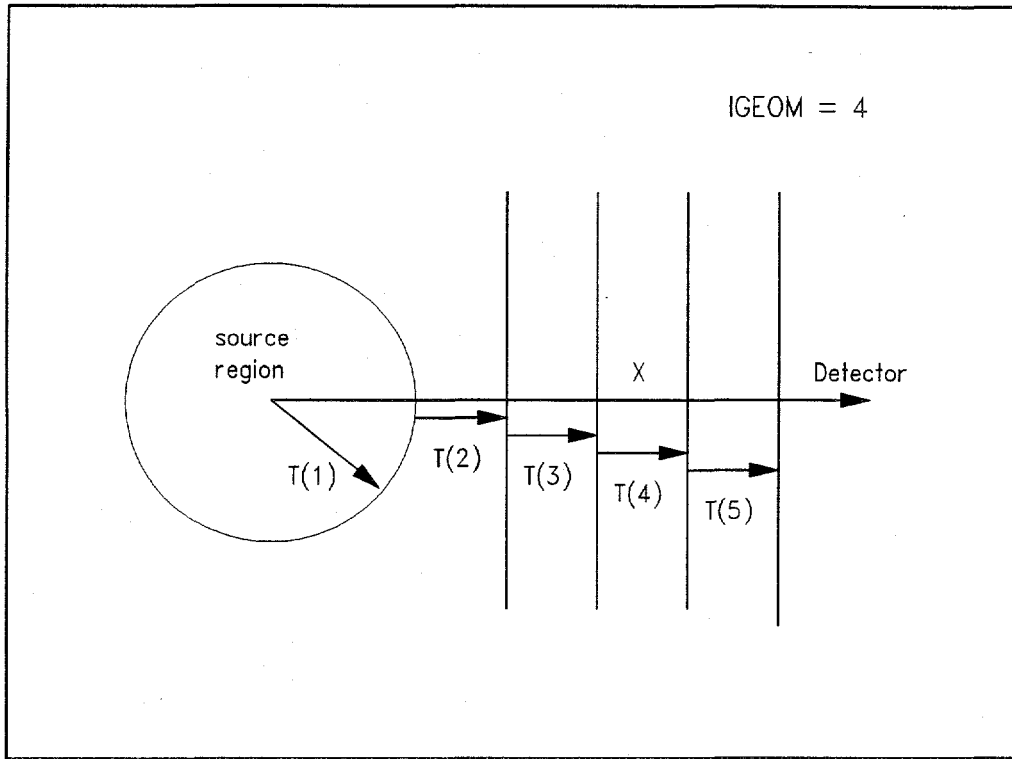

Input Variables:

Same as for IGEOM=3 except shields 3, 4, and 5 are now slabs. Note that the second shield is not a slab! It fills the space between the spherical source and the first slab.

2.3.5.5 Truncated Cone/Infinite Slab - Slab Shields (IGEOM = 5).

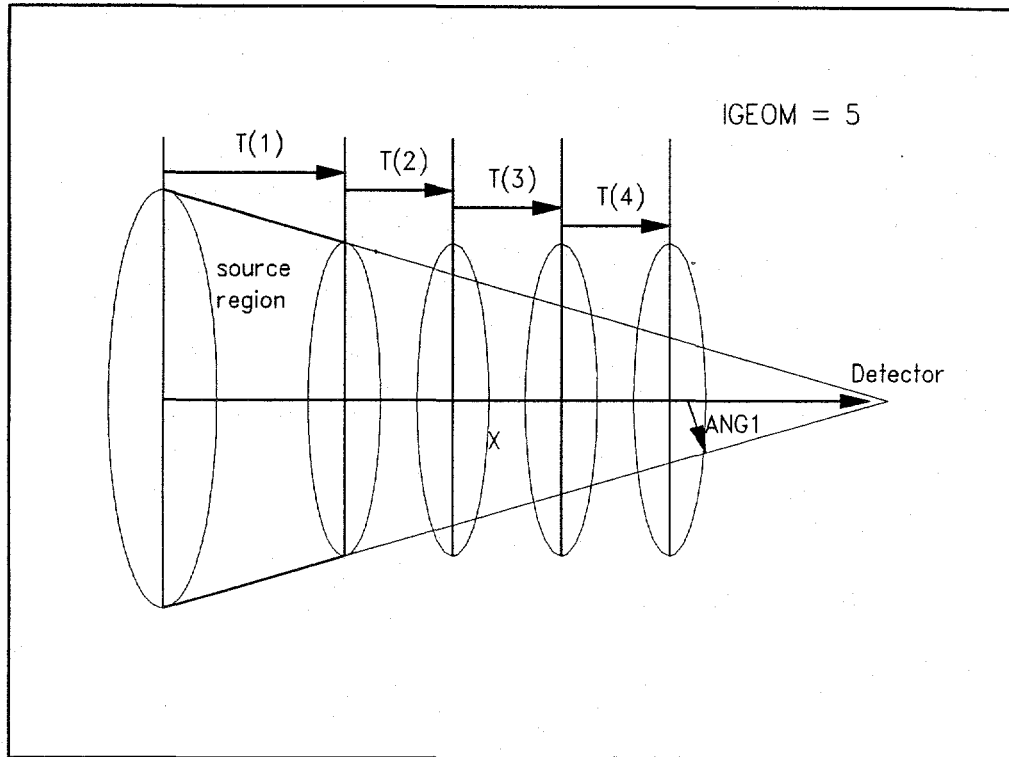

Input Variables:

X = Distance from base of the cone to the dose point. With Version 1.8 this became an array of 40 elements to allow multiple distance cases.

ANG1 = Cone vertex angle, 0° to 90°. If the vertex angle is 90°, the source is treated as an infinite slab with thickness T(1). For infinite slabs, the source is automatically interpreted as $\mu\text{Ci/cc}$ regardless of the value for ICONC.

T(1) = Thickness of the source region. If T(1) = 0 cm, the source is treated as a disc. Concentrations are expressed in $\mu\text{Ci/cm}^2$.

T(2)..T(5) = Thicknesses of the remaining slabs

TRUNC = If multiple cases are used, TRUNC controls how the change in distance affects the source dimensions and volume. Allowable values for TRUNC are described below:

- TRUNC = 0 default, ANG1 is constant as the distance changes
- TRUNC = 1 vary ANG1 to keep the source volume constant
- TRUNC = 2 vary ANG1 to keep the face area of the source constant
- TRUNC = 3 vary ANG1 to keep the rear area of the source constant

2.3.5.6 Disc Source - Slab Shields (IGEOM = 6).

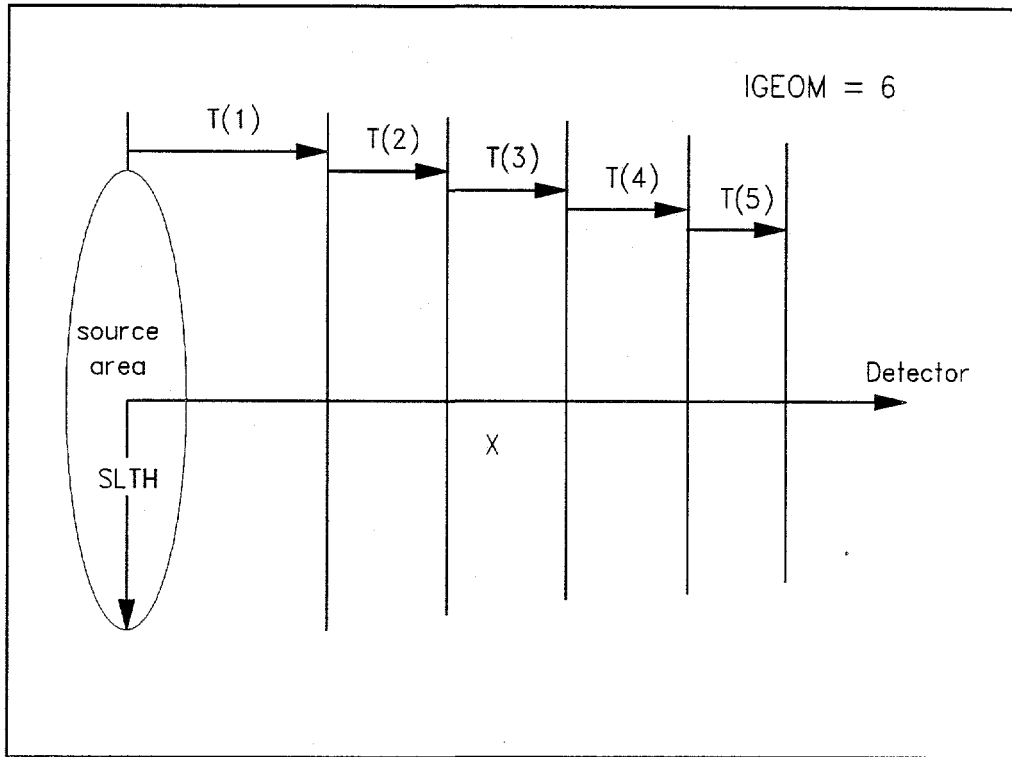

Input Variables:

SLTH = Radius of the disc

X = Distance from the center of the disc to the dose point. With Version 1.8 this became an array of 40 elements to allow multiple distance cases.

T(1) = Thickness of first shield, the source disc. The composition of the first shield determines the amount of bremsstrahlung computed for beta emitters (assuming ISPEC is 2 or 3).

T(2)..T(5) = Thicknesses of the remaining slabs

NOTE: This is very similar to IGEOM=5 with T(1)=0. However, the disc source has five shield regions because T(1) has not been used to define a thin source.

2.3.5.7 Clindrical Source - Cylindrical Shields (IGEOM = 7).

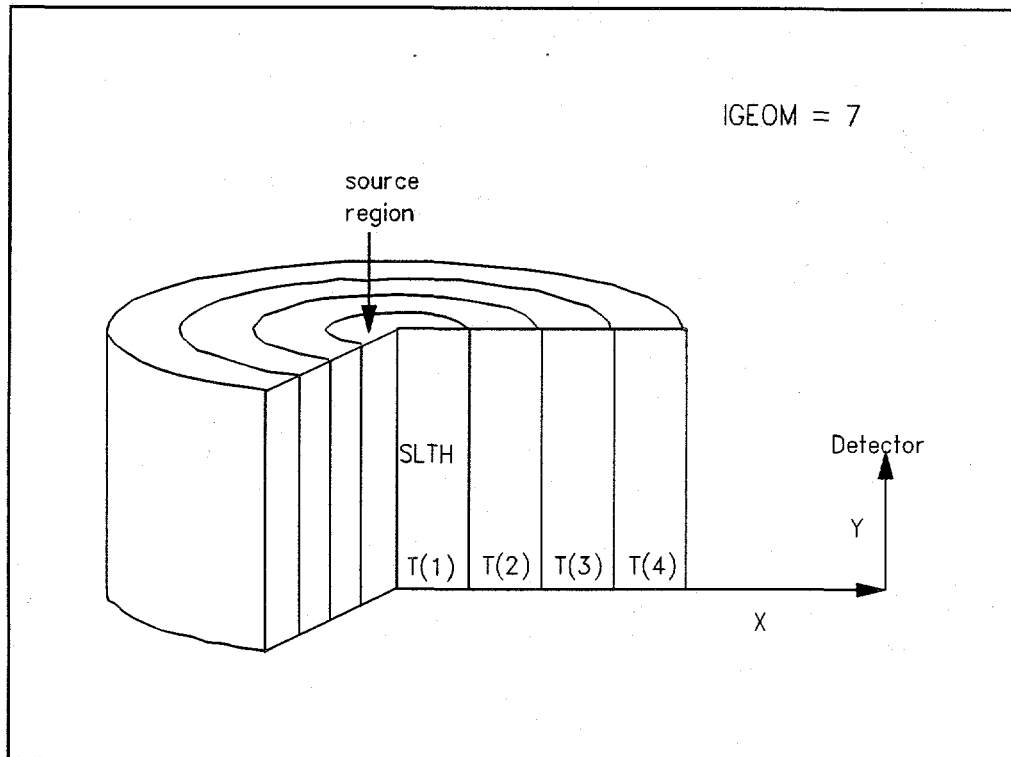

Input Variables:

SLTH = Height of cylinder, measured along the central axis

X = Distance from the centerline of the cylinder to the dose point. With Version 1.8 this became an array of 40 elements to allow multiple distance cases.

Y = Distance along the centerline from one end of the cylinder to the detector. If $Y > SLTH$ the program sets $Y = 0$.

T(1) = Radius of the cylinder

T(2)..T(5) = Thicknesses of the remaining shields (cylindrical)

NTHETA = Number of equal angle divisions perpendicular to the axis of the cylinder. The common vertex is the dose point. The angles span the area between the axis and one edge of the cylinder.

NPSI = Number of equal angle divisions parallel to the axis of the cylinder. The common vertex is the dose point. The angles span the area between Y and the farthest end of the cylinder.

DELR = Length of the radial intervals along a diameter of the cylinder at Y.

2.3.5.8 Cylindrical Source - Slab Shields (IGEOM = 8). This is the same as IGEOM=7 except that shield 2 surrounds the source and shields 3, 4, and 5 are slabs. T(2) is the distance from the outside of the cylinder to the first slab. A view of this arrangement is shown below.

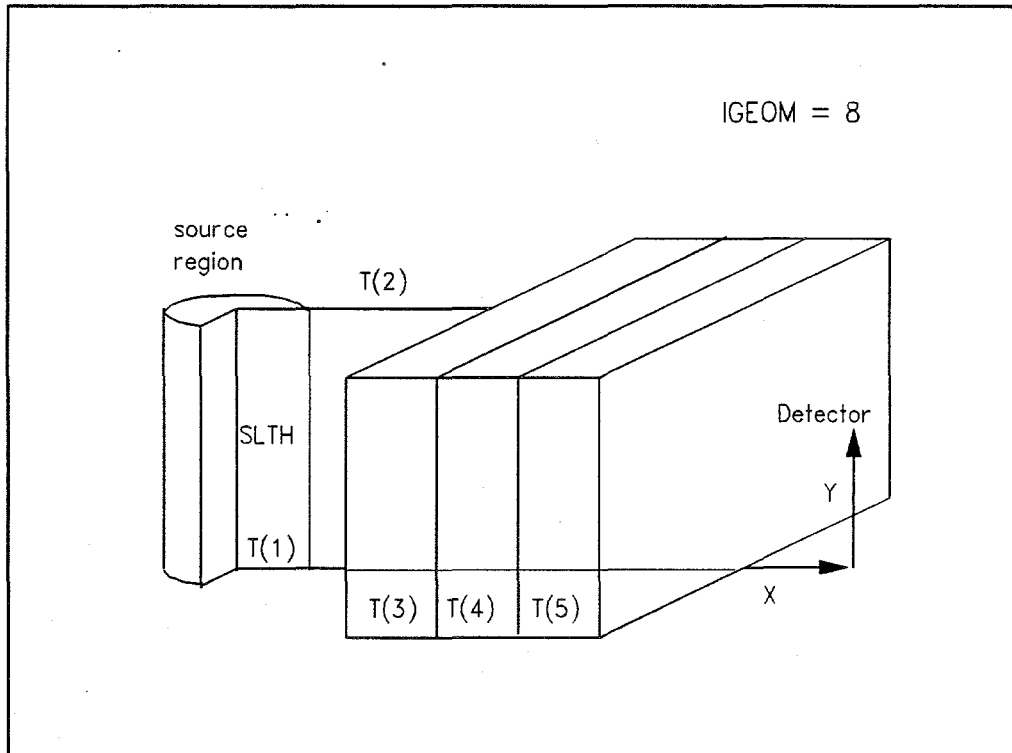

Notice that the second shield is not a slab. The thickness and composition of this shield are important. Errors in the input may significantly bias the output dose rates.

2.3.5.9 End of Cylinder - Slab Shields (IGEOM = 9).

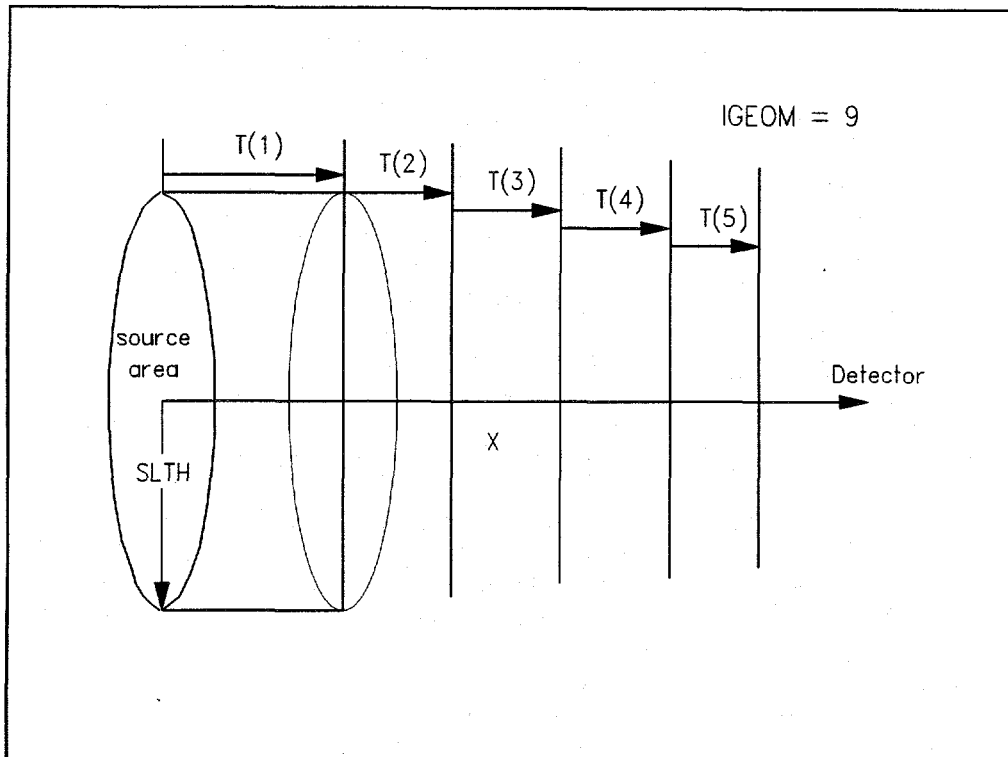

Input Variables:

SLTH = Radius of the cylinder.

X = Distance from the bottom of the cylinder to the detector. With Version 1.8 this became an array of 40 elements to allow multiple distance cases.

T(1) = Thickness of source, i.e., the length of the cylinder

T(2)..T(5) = Thicknesses of the remaining slabs

NTHETA = Number of equal angle divisions. The common vertex is the dose point. The angles span the area between the axis and one edge of the cylinder.

DELR = Length of the radial intervals along the axis of the cylinder.

2.3.5.10 Rectangular Source - Slab Shields (IGEOM = 10).

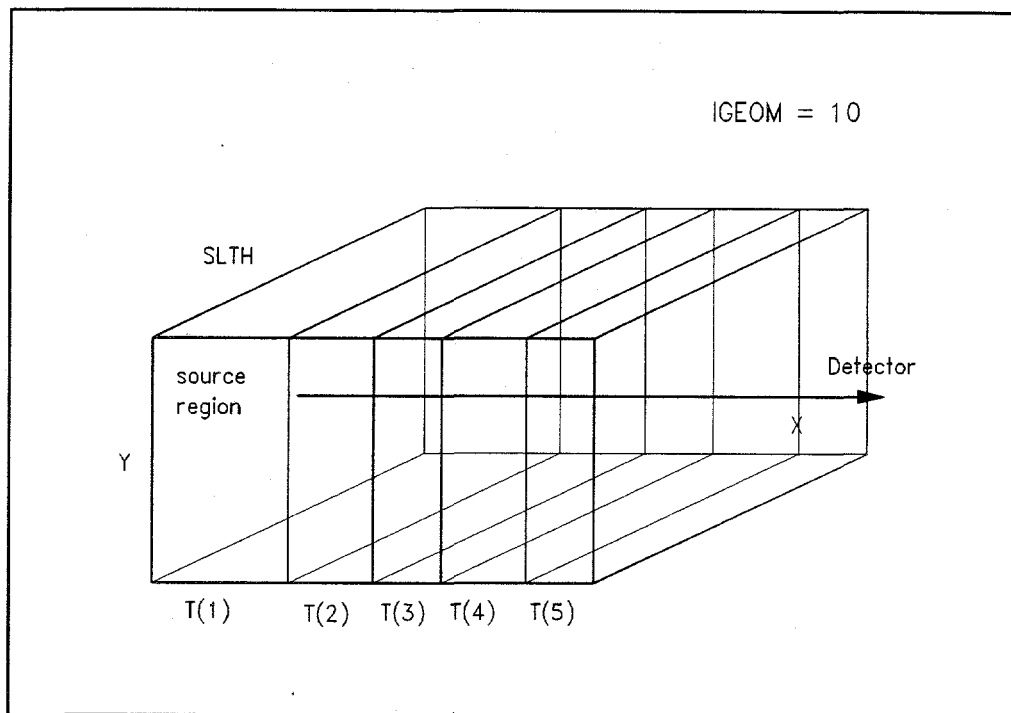

Input Variables:

X = Distance from the bottom of the box to the detector. With Version 1.8 this became an array of 40 elements to allow multiple distance cases.

T(1) = Depth of the box

T(2)..T(5) = Thicknesses of the remaining slabs

Y, SLTH = Height and width of the box, respectively

NPSI = Number of divisions into which Y/2 is divided

NTHETA = Number of divisions into which SLTH/2 is divided

DELR = Length of the integration interval along X

Note 1: For IGEOM 9 and 10, the numeric integration begins on the surface nearest the detector and proceeds down into the surface until either the far surface is reached or the dose contribution from an underlying volume element is <0.01% of what the same size element gave on the surface.

Note 2: IGEOM=10 computes dose rates only at the center of the face of the source. Dose rates at the center of one edge of the slab can be computed by doubling the length of the other edge, and halving the source concentration. This keeps the total activity in the source constant. In a similar manner, the dose rates at the corner can be found by doubling Y and SLTH, but keeping the total number of curies fixed, i.e., dividing the source concentration by 4.

2.3.5.11 Cylindrical Source - Cylindrical and Slab Shields (IGEOM = 11).

This is the same as IGEOM=8 except that shield 2 is a cylinder and shield 3 fills the gap between shield 2 and the first slab, shield 4. Shields 4 and 5 are slabs. A view of this arrangement is shown below.

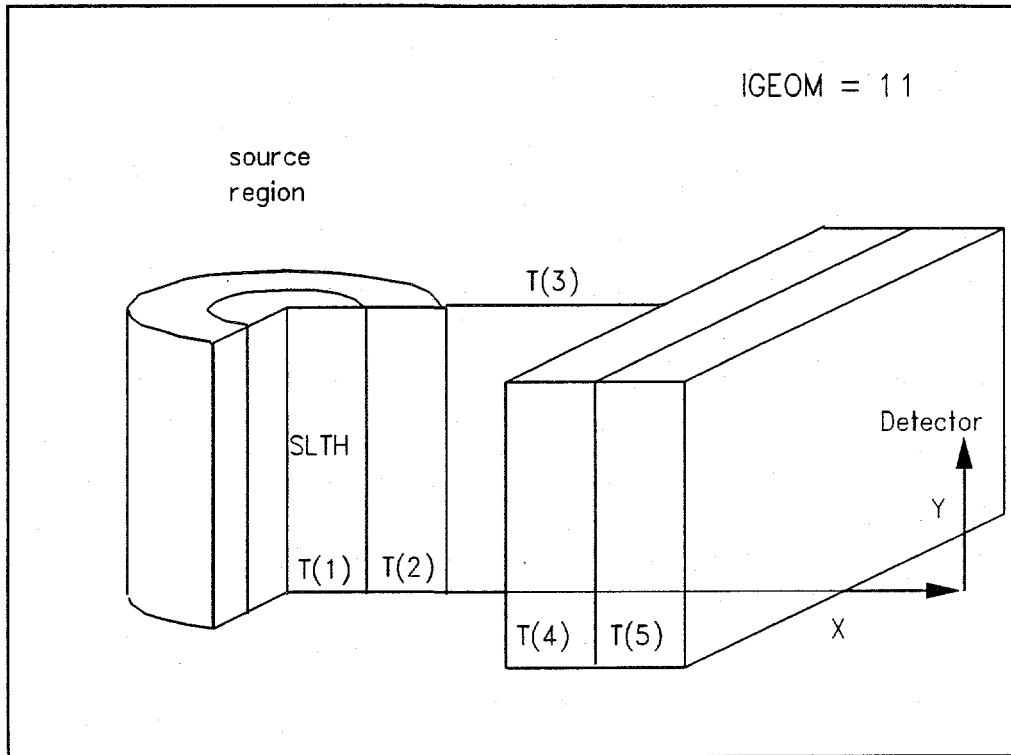

NOTE: The third shield is not a slab! It fills the gap between regions 2 and 4.

2.3.5.12 Annular Cylindrical Source - Cylindrical and Slab Shields (IGEOM = 12). This is the same as IGEOM=11 except that shield 2 is the source region and shield 3 is inserted on both sides of the source. Shield 4 surrounds the source and shield 5 is a slab. T(2) is the thickness of the source region. T(4) is the distance from the outside of the third shield to the slab.

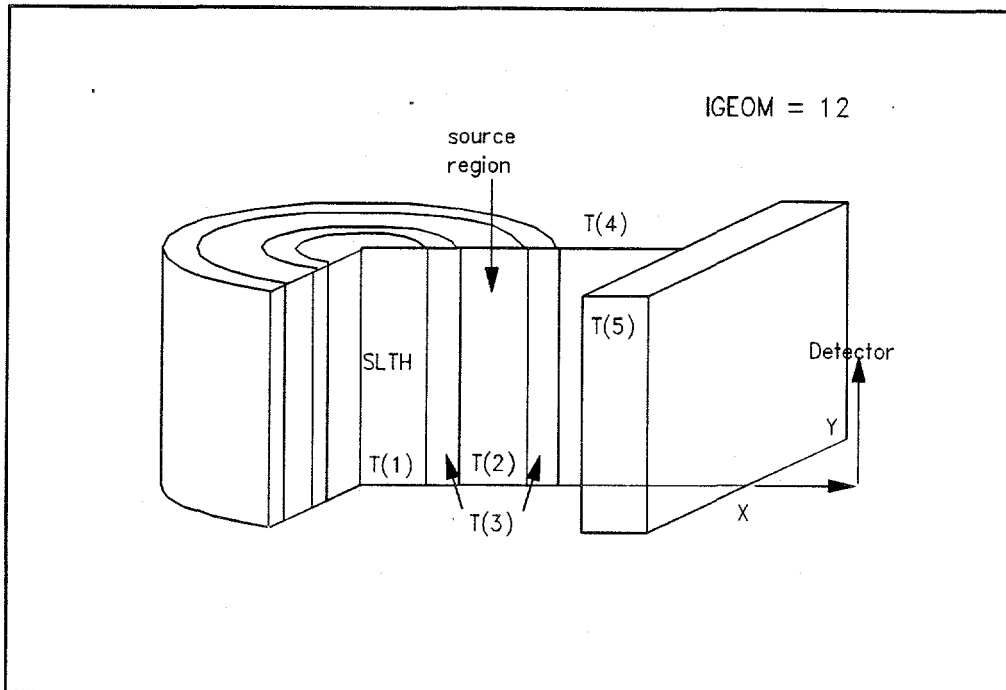

Input Variables:

- SLTH = Height of hollow cylinder, measured along the central axis
- X = Distance from the centerline of the cylinder to the dose point. With Version 1.8 this became an array of 40 elements to allow multiple distance cases.
- Y = Distance along the centerline from one end of the cylinder to the detector. If $Y > SLTH$ the program sets $Y = 0$.
- T(1) = Radius of the shield contained within the hollow cylinder
- T(2) = Thickness of the source region, the hollow cylinder itself
- T(3) = Thickness of the material coating the hollow cylinder, inside and out.
- T(4) = Thickness of the gap between the outer cylinder and the slab shield
- T(5) = Thickness of the slab, the outermost shield
- NTHETA = Number of equal angle divisions perpendicular to the axis of the cylinder. The common vertex is the dose point. The angles span the area between the axis and one edge of the hollow cylinder.
- NPSI = Number of equal angle divisions parallel to the axis of the cylinder. The common vertex is the dose point. The angles span the area between Y and the farthest end of the hollow cylinder.
- DELR = Length of the radial intervals along a diameter of the hollow cylinder at Y.

2.3.6 Error Messages from Improper Input

Improper input will result in one of two types of error messages. One type is generated by ISO-PC when an illegal value for some needed variable is found. The other is generated by the FORTRAN compiler when it is unable to translate the letters and numbers in the input file into values that can be used by ISO-PC.

Error messages generated by ISO-PC mention the source of the problem so that the input can be corrected. Examples are shown in the Table 2-4 for all of the namelist variables.

Error messages that originate with the FORTRAN compiler rather than the program are produced under the following conditions:

- Improper numbers, such as 4o (should be 40), or 15,24 (should be 15.24)
- Improper array indices, such as T(7)
- Entering multiple values for a scalar, such as IGEOM=8,9
- Misspelled namelist variable names, such as WIEGHT.

Error messages generated by the compiler are more cryptic than program-generated messages. However, they still provide useful information on the location of the problem. Compiler-generated messages give a brief description followed by a reference to the Lahey Compiler Manual. Additional information will be given if the error occurred during the reading of a file. The additional information is in the form of four variables named FILE, UNIT, RECORD, and POSITION. The FILE variable refers to the DOS name of the file being read. Typically this would be the input file. The UNIT variable is the FORTRAN file unit assigned to this FILE. Input files use UNIT=5; the attenuation and photon library uses UNIT=9. The RECORD variable refers to the line number at which the problem occurred. The character at which the error was discovered is assigned to the POSITION variable. The error message may not make sense, but having the position in the input file where the problem occurred allows most problems to be corrected.

In the following example, the input file (ERR-5.) has a namelist variable misspelled in line 4. The POSITION=19 points to the first character after the misspelled namelist variable. The first line of the error message says "Variable name not found". This means that after the compiler read the name of this variable, it compared the name with the list of allowed variables and could not find it on the list. The RECORD and POSITION variables enable the alert user to go directly to the offending text and correct it.

Table 2-4. Examples of Error Messages. (sheet 1 of 2)

Namelist variable	Acceptable range	Consequence if unacceptable
ANG1	IGEOM=2: 0° to 180° IGEOM=5: 0° to 90°	Run ends with the message, "ANG1 is outside the allowed range from 0 to 180!". If IGEOM=5 and ANG1 is between 90° and 180°, ANG1 is changed to be 90°, and the run continues.
ANG2	ANG1-90° to ANG1+90°	Run ends with the message, "ANG2 is outside the valid range from XX.XX to YY.YY degrees!". The values displayed in the final message depend on the value for ANG1.
DELR	IGEOM=1-11: < T(1)/5 IGEOM=12: < T(2)/5	DELR is changed to 0.2 times the source thickness
DUNIT	0 to 7	If DUNIT < 0 then DUNIT = 0 If DUNIT > 7 then DUNIT = 7
ICONC	0 or 1	If ICONC < 0 then ICONC = 0 If ICONC > 1 then ICONC = 1
IGEOM	1 to 12	Run ends with the message, "IGEOM is outside the allowed range from 1 to 12"
IPRNT	any	--
ISPEC	1, 2, or 3	If ISPEC < 1 then ISPEC = 1 If ISPEC > 3 then ISPEC = 3
JBUF	1 to NSHLD	If JBUF < 1 or JBUF > NSHLD then JBUF = NSHLD
NEXT	1 to 6	If NEXT < 1 then NEXT = 1 If NEXT > 6 then NEXT = 6
NPSI	5 or more; odd	NPSI is changed to 5; also, is changed to the next larger integer if even
NSHLD	1, 2, 3, 4, or 5 IGEOM=12: 3, 4, or 5	If NSHLD < 1 then NSHLD = 1 If NSHLD > 5 then NSHLD = 5 If IGEOM=12 and NSHLD<3 the run ends showing the message, "With IGEOM=12, there must be at least 3 shields!"
NTHETA	5 or more; odd	NTHETA is changed to 5; is changed to the next larger integer if even
OPTION	any integer	--
SFACT	>0	Run ends with the message, "SFACT must be greater than zero!!"

Table 2-4. Examples of Error Messages. (sheet 2 of 2)

Namelist variable	Acceptable range	Consequence if unacceptable
SLTH	>0	Run ends with the message, "SLTH must be greater than zero!!"
SOURCE	two-dimensional array: 1st dimension: 1, 2, 3 2nd dimension: 1 to 30	Compiler-generated messages only.
SSV1	zero	Displays message, "Input for SSV1 has been ignored."
T	index from 1 to 6; T(1) >0 except for IGEOM=5	Run ends with the message, "T(1) must be greater than zero!"
TRUNC	0 to 3	TRUNC is changed to 0
WEIGHT	index from 1 to 550	Current library has 535 nuclides; values for array indices 536 to 550 are ignored
X	index from 1 to 40; X(1) > 0	Run ends with the message, "X must be greater than zero!!"
Y	for cylinders from side: $0 \leq Y \leq \text{SLTH}$	Y is changed to 0

Example Input File With Misspelled NAMELIST Variable

```

0      2 Standard 55 gallon Drum with Cs & Sr Contaminated Waste
Low Density Source, 3 ft Away
&Input Next=1,
  IGeom= 8, SLNTH= 82, Y= 41, T(1)= 28, 0.16, X= 119.6,
  NShld= 2, JBuf= 1, NTheta= 9, NPsi= 11, Delr= 2.0, Option= 1,
  Weight(82)= 7, Weight(84)= 7, Weight(335)= 1, 0.946 &
  misc 2 0.01
1 iron 9 7.86
Low Density Source, Contact (2 inches)
&Input Next= 4, x= 33.24 &
This is the End of the Drum Case !!
&Input Next= 6 &

```

This generates the following error message:

```

-----
Variable name not found (See Section 9.8.4 in Lahey FORTRAN Language System
Reference Manual [Lahey 1990]),
FILE=ERR-5., UNIT=5, RECORD=4, Position=19 in CONTRL at line 807
Called by ISOSHL D at line 257

```

2.4 OUTPUT FILE ORGANIZATION

An example of an output file is shown in Appendix E. This is the output generated by the sample input file given in Section 2.3.1. It illustrates most of the possible output that can be generated by ISO-PC.

2.4.1 Output Header and Titles

The first line of the output file shows the time and date on which the output was generated. The time and date are read from the system clock. If the time or date is incorrect, the computer's clock will need to be reset using the DOS commands for TIME and DATE.

The next several lines show the code version and release date. Also displayed is the name, address, and phone number of someone who is willing to help with problems. If any new bugs are uncovered, please report them to this individual.

After this identification block, the program lists the title line from the main data file. Also shown is the name of the library file. The actual library format has not changed except for the addition of the title line.

The last title displayed is the run title. After the run title comes the output from each case.

2.4.2 Source Inventory (MODE=2)

In MODE=3, this table is not generated. In MODE=2, when any WEIGHT values change or SFACT changes, the program lists the nuclides and amounts it will use in this case as well as the amounts entered by the user. The list has been sorted by atomic number.

Three columns appear in the "Table of Source Activity". The first is the nuclide name. The second is the actual WEIGHT values input by the user. The third is the adjusted values according to the value for SFACT, which is listed just above the table. The units at the top of the last column depend on the value for ICONC.

If ISPEC is not equal to 3, the program only uses gamma or bremsstrahlung photons, not both. A reminder of this fact appears after the source table. In the example, ISPEC=3 by default, so no reminder is given. Both gamma and bremsstrahlung photons will be used.

2.4.3 Shield Composition and Attenuation Coefficients

If NEXT=1 or NEXT=3, the program reads the shield composition lines from the input file and computes attenuation coefficients for each shield. The composition of the shields and the resulting attenuation coefficients are listed in the next table of Appendix E. If IPRNT=1, the attenuation coefficient table is not printed.

The linear attenuation coefficients are in units of inverse centimeter. The last shield region is inserted by ISO-PC. This last region is always air with a density of 0.001293 g/cc. At great distances between the source and detector, this density may not represent the actual amount of material adequately. In these cases, one should specify an air shield region to replace the extra shield inserted by ISO-PC. If this user-generated outer region is large enough, the ISO-PC air thickness will be set to zero by the program, and the thickness of the user's outer region will be adjusted to fill the space between the source and detector.

The photon energies shown on the table are one of the following:

MODE=2 photon energy group midpoint values
MODE=3 photon energies entered by the user.

The library values for mass attenuation were determined at the standard ISOSHL D energy group midpoints. Photon energies entered by the user in MODE=3 will typically differ from the ISOSHL D energies. The program computes attenuation coefficients at these energies by log-log interpolation between the ISOSHL D energy values. The linear attenuation coefficients for shields composed of multiple materials are added together to give the value shown on the table.

2.4.4 Photon Production by Nuclide (OPTION=1)

If MODE=2 and OPTION=1, any shield composition namelist changes (such as to ISPEC or WEIGHT) that may change the photon production rate will generate the tables of photon production by nuclide. The value for IPRNT has no effect on these tables. The first table shows the energy group structure used by ISOSHL D. Different energy photons are combined into energy group bins. The low and high energy, as well as the midpoint energy, are shown for each bin.

The remaining tables show the gamma (and x-ray) photons and the bremsstrahlung photons characteristic of each nuclide. The photon production rates correspond to the adjusted WEIGHT amount shown in the last column of the source activity table.

If ISPEC=1, the bremsstrahlung column is all zero. If ISPEC=2, the gamma and x-ray column is all zero. Some nuclides are stable, and thus will show only zero.

2.4.5 Geometry Summary and Dose Rates

The geometry summary begins with the case title, and echoes all the input for this case. Additional information is also provided about the source, such as its area or volume. In the case of volume sources, the total mass of the source in grams is given. Where integration variables are required, the total number of integration intervals is shown. The shield thicknesses include the last shield region of air inserted by the program. The atomic number of the shield region used for computation of buildup factor is shown for information.

The dose rates are shown in either a table (IPRNT=0) or a one-line summary (IPRNT=1). The table shows dose rate by energy group in the last column, which allows one to identify the group that gives most of the final dose rate. The other columns of the table are (1) the photon group energy, (2) the total number of photons per second being emitted by the source each second, (3) the fluence-to-dose factor for this group, and (4) the energy fluence at the dose point, in meV per square centimeter per second.

If DUNIT=7, the normal dose rate table uses DUNIT=0, and an additional table shows the dose equivalent rates for the other values of DUNIT. If IPRNT=1, only the totals line from this second table is printed. If OPTION=1, a third table is printed that shows the fluence-to-dose conversion factors used in this run.

If multiple values for X are entered, additional summaries and dose rate tables are generated. These additional tables differ from the first table by having a line immediately following the case title line which shows which of the distances (2, 3, 4, and up to 40) was used for this case.

2.4.6 Input Data File Listing

The last thing added to the output file is the input file that generated it. This is done to ensure completeness. It also provides a spare copy of the input file if the original copy is lost. Note that the run ends with NEXT=6, so that comment lines may be added after the final namelist block to explain any special input values. The example input file illustrates the use of this dead space for comments.

The name of the input file is printed just before the input file listing begins. The line before that has the time and date at which the computations ended and the program began to copy the input file into the output file.

2.4.7 Warning Messages

Potential problems with the input are identified in the output with warning messages. Such messages note changes in input parameters, or processing which may lead to inaccuracies in the final dose rates. Users should evaluate any warning messages in their output to decide whether additional runs with modified input are necessary. The four warning messages that can be generated by ISO-PC Version 1.98 are shown below.

- When setting the thickness of the extra air shield, the program may reduce the thickness of the outer shield. If the thickness of the outer shield was changed from 123.4 to 5.0 cm, the following warning is given:

WARNING: Thickness of outer shield was changed from 1.234E+02 to 5.000E+00 cm!

- For the line source (IGEOM=2) the program may increase the thickness of the first shield to keep the source inside it. If the first shield is increased from 5.0 to 7.23 cm, the following warning is given:

WARNING: Thickness of first region increased so the line fits inside.
Old T(1): 5.000E+00 cm New T(1): 7.230E+00 cm

- The line (IGEOM=2), spheres (IGEOM=3 & 4), the disc (IGEOM=6), and sometimes the truncated cone (IGEOM=5) use a special subroutine to do a one-dimensional numeric integration. The integration doubles the number of intervals and computes the change in the energy fluence at the dose point. If the dose rate changes by more than 0.1%, the doubling is repeated. If the number of intervals reaches 4096 and the percent change is still greater than 0.1%, a warning message is given and the program continues. The message looks something like the following:

WARNING: Simpsons integral converges slowly! (N=4096)
A,B: 0.000E+00 5.000E+00 Sums: 6.355E-15 6.362E-15 Rel Diff: 1.1E-03

The actual numbers printed in the message are usually different. "A,B" are the limits of integration. In this case, the integral is from 0 to 5. "Sums" represent the computed dose rate for this energy group prior to application of the initial energy fluence and fluence-to-dose conversion factor. "Rel Diff" is the relative difference between the sums. In this case, it is only slightly larger than the desired value (0.001), so there is no need for concern.

- In MODE=3, the user may enter values for photon energy that are outside the allowed photon energy range. If so, the program prints the following message at the end of each geometry summary, just before the dose rate table:

WARNING: Allowed Photon Energy Range is from 0.010 meV to 10.000 meV !!

2.5 REPORTING PROBLEMS OR COMMENTS

The author of this version is convinced that it offers significant improvements over previous versions, both in user conveniences as well as improved algorithms and error trapping. However, there is an axiom in computer programming known as Lubarsky's Law of Cybernetic Entomology which states, "There is always one more bug." This software is released to the public domain with that understanding.

Should you suspect a bug, or discover any error in either this user's guide or the computations carried out by ISO-PC, please notify the following individual by the most convenient means:

Paul D. Rittmann
Westinghouse Hanford Company H6-30
P.O. Box 1970
Richland, WA 99352

Phone: 509-376-8715

Fax: 509-372-1033

This notification is a necessary first step toward warning other known users and correcting the problem.

3.0 REFERENCES

- ANSI/ANS, 1977, *American National Standard for Neutron and Gamma-Ray Flux-to-Dose-Rate Factors*, ANSI/ANS-6.1.1-1977, American Nuclear Society, La Grange Park, Illinois.
- ANSI/ANS, 1991a, *American National Standard for Neutron and Gamma-Ray Fluence-to-Dose Factors*, ANSI/ANS-6.1.1-1991, American Nuclear Society, La Grange Park, Illinois.
- ANSI/ANS, 1991b, *American National Standard for Gamma-Ray Attenuation Coefficients and Buildup Factors for Engineering Materials*, ANSI/ANS-6.4.3-1991, American Nuclear Society, La Grange Park, Illinois.
- Brown, R. C., 1991, *Soil Density and Mass Attenuation Coefficients for Use in Shielding Calculations at the Hanford Waste Vitrification Plant*, WHC-SD-HWV-TI-020, Rev. 0, Westinghouse Hanford Company, Richland, Washington.
- Croff, A. G., 1980, *ORIGEN2 - A Revised and Updated Version of the Oak Ridge Isotope Generation and Depletion Code*, ORNL-5621, Oak Ridge National Laboratory, Oak Ridge, Tennessee.
- Engle, R. L., J. Greenberg, and N. M. Hendrickson, 1966, *ISOSHLD - A Computer Code for General Purpose Isotope Shielding Analysis*, BNWL-236, Pacific Northwest Laboratories, Richland, Washington.
- Goldstein, H., 1959, *Fundamental Aspects of Reactor Shielding*, Addison-Wesley Publishing Co., Inc., Reading, Massachusetts.
- Kocher, D. C., 1981, *Radioactive Decay Data Tables*, DOE/TIC-11026, U.S. Department of Energy, Office of Scientific and Technical Information, Oak Ridge, Tennessee.
- Lahey, 1990, *Lahey FORTRAN Language System Reference Manual*, Rev. B, Lahey Computer Systems, Inc., Incline Village, Nevada.
- Lourant, I. O., and P. D. Rittmann, 1989, *Validation of ISOSHLD-II*, WHC-SD-SQA-CSWD-303, Rev. 0, Westinghouse Hanford Company, Richland, Washington.
- Mansius, C. A., 1969, *A Revised Photon Probability Library for Use with ISOSHLD-III*, BNWL-236-SUP2, Pacific Northwest Laboratories, Richland, Washington.
- Rittmann, P. D., 1992, *BREMCALC - A Computer Program for Calculating Electron and Positron Bremsstrahlung*, WHC-SA-1435-FP, Westinghouse Hanford Company, Richland, Washington.
- Rockwell III, T., 1956, *Reactor Shielding Design Manual*, D. Van Nostrand Company, Inc., New York.

Simmons, G. L., J. J. Regimbal, J. Greenborg, and H. H. Van Tuyl, 1967, *ISOSHL D-II: Code Revision To Include Calculation of Dose Rate From Shielded Bremsstrahlung Sources*, BNWL-236-SUP1, Pacific Northwest Laboratories, Richland, Washington.

Storm, E., E. Gilbert, and H. Israel, 1958, *Gamma-Ray Absorption Coefficients for Elements 1 through 100 Derived from the Theoretical Values of the National Bureau of Standards*, LA-2237, Los Alamos Scientific Laboratory, Los Alamos, New Mexico.

Van Tuyl, H. H., 1964, *BREMRAD - A Computer Code for External and Internal Bremsstrahlung Calculations*, HW-83784, U.S. Government Printing Office.

4.0 BIBLIOGRAPHY

Bureau of Radiological Health, 1970, *Radiological Health Handbook*, U.S. Department of Health, Education, and Welfare, Public Health Services, Food and Drug Administration, Bureau of Radiological Health, Rockville, Maryland.

Jaeger, R. G. et al., Editor, 1975, *Engineering Compendium on Radiation Shielding*, Volume 2, Springer Verlag, New York, New York.

This page intentionally left blank.

APPENDIX A

VALUES FOR MASS ATTENUATION COEFFICIENTS

Values for Hanford Site soil are from WHC-SD-HWV-TI-020, Rev. 0, *Soil Density and Mass Attenuation Coefficients for Use in Shielding Calculations at the Hanford Waste Vitrification Plant*, R. C. Brown, 1991, Westinghouse Hanford Company, Richland, Washington. All other values are from LA-2237, *Gamma-Ray Absorption Coefficients for Elements 1 through 100 Derived from the Theoretical Values of the National Bureau of Standards*, E. Storm, E. Gilbert, and H. Israel, 1958, Los Alamos Scientific Laboratory, Los Alamos, New Mexico.

This page intentionally left blank.

Mass Attenuation Coefficients, cm²/g

Energy meV	WATER	TISSUE	AIR	ORD CONC	HAN SOIL	HVY CONC
	Zb= 6.60	Zb= 6.57	Zb= 7.36	Zb=11.50	Zb=12.66	Zb=18.53
	Za= 3.33	Za= 3.44	Za= 7.26	Za= 9.39	Za=10.78	Za=11.81
	AW= 6.01	AW= 6.28	AW=14.55	AW=18.77	AW=21.83	AW=24.40
0.015	1.640	0.8913	1.586	8.481	12.20	35.75
0.025	0.4959	0.4168	0.4758	1.984	2.835	8.491
0.035	0.3030	0.3296	0.2840	0.8251	1.135	3.278
0.045	0.2387	0.2967	0.2199	0.4708	0.6158	1.626
0.055	0.2118	0.2800	0.1931	0.3306	0.4058	0.9685
0.065	0.1979	0.2688	0.1794	0.2629	0.3045	0.6558
0.075	0.1872	0.2593	0.1693	0.2238	0.2488	0.4809
0.085	0.1793	0.2515	0.1620	0.1997	0.2151	0.3759
0.095	0.1733	0.2450	0.1565	0.1838	0.1932	0.3091
0.150	0.1513	0.2165	0.1363	0.1438	0.1430	0.1730
0.250	0.1269	0.1835	0.1145	0.1164	0.1147	0.1205
0.350	0.1118	0.1619	0.1006	0.1016	0.1002	0.1017
0.475	0.09880	0.1435	0.08883	0.08954	0.08797	0.08808
0.650	0.08627	0.1254	0.07761	0.07800	0.07669	0.07620
0.825	0.07743	0.1122	0.06964	0.06996	0.06869	0.06805
1.000	0.07058	0.1024	0.06352	0.06374	0.06260	0.06191
1.225	0.06386	0.09283	0.05735	0.05758	0.05661	0.05588
1.475	0.05807	0.08438	0.05208	0.05233	0.05154	0.05086
1.700	0.05383	0.07812	0.04844	0.04863	0.04793	0.04733
1.900	0.05068	0.07339	0.04565	0.04592	0.04527	0.04481
2.100	0.04808	0.06938	0.04313	0.04364	0.04301	0.04273
2.300	0.04572	0.06581	0.04080	0.04164	0.04108	0.04092
2.500	0.04368	0.06266	0.03878	0.03993	0.03940	0.03934
2.700	0.04189	0.05998	0.03704	0.03840	0.03795	0.03798
3.000	0.03962	0.05641	0.03497	0.03649	0.03610	0.03632
3.600	0.03597	0.05079	0.03223	0.03347	0.03327	0.03381
4.500	0.03196	0.04451	0.02904	0.03023	0.03026	0.03125
5.500	0.02884	0.03942	0.02621	0.02780	0.02796	0.02944
6.600	0.02640	0.03545	0.02412	0.02598	0.02624	0.02817
8.600	0.02344	0.03037	0.02148	0.02387	0.02436	0.02680

Mass Attenuation Coefficients, cm²/g

Energy meV	HYDROGEN	LITHIUM	CARBON	NITROGEN	OXYGEN	FLUORINE
	Zb= 1.00	Zb= 3.00	Zb= 6.00	Zb= 7.00	Zb= 8.00	Zb= 9.0
	Za= 1.00	Za= 3.00	Za= 6.00	Za= 7.00	Za= 8.00	Za= 9.0
	AW= 1.008	AW= 6.94	AW=12.01	AW=14.01	AW=16.00	AW=19.0
0.015	0.3750	0.2110	0.7770	1.200	1.800	2.480
0.025	0.3618	0.1687	0.3073	0.3924	0.5128	0.6393
0.035	0.3504	0.1575	0.2235	0.2547	0.2970	0.3358
0.045	0.3398	0.1509	0.1936	0.2067	0.2260	0.2391
0.055	0.3305	0.1454	0.1794	0.1859	0.1969	0.2003
0.065	0.3215	0.1408	0.1708	0.1749	0.1823	0.1815
0.075	0.3130	0.1369	0.1631	0.1664	0.1713	0.1681
0.085	0.3053	0.1332	0.1573	0.1601	0.1634	0.1587
0.095	0.2984	0.1297	0.1529	0.1552	0.1575	0.1519
0.150	0.2650	0.1150	0.1350	0.1360	0.1370	0.1300
0.250	0.2254	0.09843	0.1142	0.1146	0.1145	0.1097
0.350	0.1990	0.08688	0.1007	0.1007	0.1008	0.09581
0.475	0.1766	0.07704	0.08886	0.08888	0.08902	0.08442
0.650	0.1543	0.06718	0.07770	0.07771	0.07773	0.07364
0.825	0.1380	0.06033	0.06970	0.06970	0.06979	0.06604
1.000	0.1260	0.05500	0.06360	0.06360	0.06360	0.06020
1.225	0.1143	0.04968	0.05738	0.05738	0.05747	0.05445
1.475	0.1039	0.04510	0.05214	0.05214	0.05225	0.04953
1.700	0.09614	0.04178	0.04852	0.04852	0.04851	0.04598
1.900	0.09023	0.03930	0.04572	0.04573	0.04573	0.04336
2.100	0.08516	0.03718	0.04311	0.04310	0.04336	0.04113
2.300	0.08079	0.03534	0.04070	0.04068	0.04130	0.03922
2.500	0.07695	0.03372	0.03858	0.03856	0.03950	0.03756
2.700	0.07355	0.03228	0.03679	0.03677	0.03793	0.03610
3.000	0.06910	0.03040	0.03470	0.03470	0.03590	0.03420
3.600	0.06189	0.02735	0.03199	0.03210	0.03271	0.03119
4.500	0.05387	0.02394	0.02864	0.02895	0.02918	0.02796
5.500	0.04744	0.02132	0.02569	0.02615	0.02651	0.02547
6.600	0.04227	0.01922	0.02346	0.02401	0.02443	0.02351
8.600	0.03570	0.01651	0.02073	0.02133	0.02189	0.02126

Mass Attenuation Coefficients, cm²/g

Energy meV	SODIUM	MAGNESIUM	ALUMINUM	SILICON	PHOSPHORUS	SULFUR
	Zb=11.00	Zb=12.00	Zb=13.00	Zb=14.00	Zb=15.00	Zb=16.00
	Za=11.00	Za=12.00	Za=13.00	Za=14.00	Za=15.00	Za=16.00
	AW=22.99	AW=24.31	AW=26.98	AW=28.09	AW=30.97	AW=32.07
0.015	4.790	6.570	8.060	10.60	12.70	16.00
0.025	1.111	1.481	1.839	2.384	2.890	3.628
0.035	0.5028	0.6353	0.7586	0.9591	1.135	1.419
0.045	0.3168	0.3805	0.4377	0.5311	0.6051	0.7320
0.055	0.2437	0.2800	0.3069	0.3629	0.3995	0.4690
0.065	0.2088	0.2313	0.2440	0.2816	0.3019	0.3472
0.075	0.1865	0.2030	0.2106	0.2357	0.2474	0.2780
0.085	0.1707	0.1847	0.1895	0.2075	0.2145	0.2373
0.095	0.1593	0.1720	0.1747	0.1890	0.1931	0.2117
0.150	0.1340	0.1390	0.1380	0.1450	0.1430	0.1500
0.250	0.1103	0.1137	0.1116	0.1165	0.1141	0.1178
0.350	0.09693	0.09998	0.09781	0.1015	0.09915	0.1022
0.475	0.08546	0.08834	0.08646	0.08946	0.08688	0.08979
0.650	0.07439	0.07689	0.07523	0.07794	0.07570	0.07802
0.825	0.06673	0.06890	0.06741	0.06978	0.06770	0.06987
1.000	0.06080	0.06280	0.06140	0.06360	0.06170	0.06360
1.225	0.05498	0.05677	0.05545	0.05739	0.05568	0.05743
1.475	0.05003	0.05165	0.05043	0.05215	0.05063	0.05225
1.700	0.04647	0.04798	0.04690	0.04850	0.04715	0.04860
1.900	0.04385	0.04529	0.04433	0.04586	0.04462	0.04595
2.100	0.04164	0.04301	0.04216	0.04363	0.04246	0.04374
2.300	0.03975	0.04106	0.04030	0.04173	0.04059	0.04188
2.500	0.03811	0.03937	0.03868	0.04009	0.03897	0.04027
2.700	0.03667	0.03790	0.03726	0.03865	0.03757	0.03888
3.000	0.03480	0.03600	0.03540	0.03680	0.03580	0.03710
3.600	0.03183	0.03303	0.03247	0.03391	0.03312	0.03433
4.500	0.02877	0.02995	0.02957	0.03084	0.03019	0.03144
5.500	0.02641	0.02767	0.02737	0.02861	0.02811	0.02942
6.600	0.02461	0.02590	0.02568	0.02699	0.02668	0.02798
8.600	0.02260	0.02379	0.02384	0.02516	0.02499	0.02629

Mass Attenuation Coefficients, cm²/g

Energy meV	CHLORINE	ARGON	POTASSUM	CALCIUM	TITANIUM	CHROMIUM
	Zb=17.00	Zb=18.00	Zb=19.00	Zb=20.00	Zb=22.00	Zb=24.00
	Za=17.00	Za=18.00	Za=19.00	Za=20.00	Za=22.00	Za=24.00
	AW=35.45	AW=39.95	AW=39.10	AW=40.08	AW=47.88	AW=52.00
0.015	18.40	20.40	25.90	30.70	37.00	47.10
0.025	4.182	4.699	5.890	7.016	8.509	10.98
0.035	1.638	1.770	2.221	2.642	3.230	4.205
0.045	0.8294	0.8849	1.108	1.314	1.592	2.047
0.055	0.5144	0.5499	0.6764	0.7915	0.9411	1.196
0.065	0.3719	0.3893	0.4689	0.5405	0.6275	0.7908
0.075	0.2925	0.3004	0.3560	0.4036	0.4551	0.5631
0.085	0.2453	0.2482	0.2905	0.3246	0.3560	0.4300
0.095	0.2153	0.2153	0.2494	0.2754	0.2948	0.3473
0.150	0.1470	0.1420	0.1570	0.1670	0.1630	0.1780
0.250	0.1136	0.1079	0.1173	0.1225	0.1146	0.1184
0.350	0.09845	0.09304	0.1007	0.1041	0.09642	0.09852
0.475	0.08643	0.08131	0.08799	0.09046	0.08376	0.08473
0.650	0.07514	0.07067	0.07623	0.07844	0.07234	0.07295
0.825	0.06718	0.06316	0.06820	0.07006	0.06464	0.06501
1.000	0.06100	0.05750	0.06210	0.06380	0.05880	0.05910
1.225	0.05509	0.05189	0.05601	0.05756	0.05301	0.05337
1.475	0.05022	0.04720	0.05093	0.05234	0.04821	0.04861
1.700	0.04679	0.04395	0.04746	0.04877	0.04493	0.04529
1.900	0.04429	0.04161	0.04498	0.04621	0.04260	0.04292
2.100	0.04219	0.03967	0.04291	0.04408	0.04068	0.04098
2.300	0.04041	0.03803	0.04114	0.04227	0.03907	0.03937
2.500	0.03887	0.03662	0.03962	0.04072	0.03770	0.03801
2.700	0.03753	0.03539	0.03830	0.03939	0.03651	0.03685
3.000	0.03580	0.03380	0.03660	0.03770	0.03500	0.03540
3.600	0.03313	0.03133	0.03399	0.03516	0.03271	0.03324
4.500	0.03051	0.02893	0.03146	0.03267	0.03057	0.03123
5.500	0.02868	0.02723	0.02973	0.03092	0.02920	0.02994
6.600	0.02734	0.02602	0.02850	0.02972	0.02821	0.02910
8.600	0.02582	0.02480	0.02719	0.02852	0.02718	0.02835

Mass Attenuation Coefficients, cm²/g

Energy meV	IRON	NICKEL	ZINC	ARSENIC	STRONTIUM	ZIRCONIUM
	Zb=26.00	Zb=28.00	Zb=30.00	Zb=33.00	Zb=38.00	Zb=40.00
	Za=26.00	Za=28.00	Za=30.00	Za=33.00	Za=38.00	Za=40.00
	AW=55.85	AW=58.69	AW=65.39	AW=74.92	AW=90.00	AW=91.22
0.015	58.80	73.20	84.10	103.00	16.90	19.50
0.025	13.95	17.61	20.42	25.17	35.54	40.69
0.035	5.326	6.732	7.821	9.733	14.03	16.29
0.045	2.589	3.256	3.789	4.731	6.879	8.019
0.055	1.499	1.889	2.197	2.740	3.967	4.608
0.065	0.9816	1.229	1.417	1.761	2.550	2.972
0.075	0.6935	0.8565	0.9757	1.204	1.751	2.056
0.085	0.5211	0.6348	0.7172	0.8774	1.265	1.486
0.095	0.4118	0.4956	0.5566	0.6737	0.9526	1.112
0.150	0.1960	0.2210	0.2350	0.2630	0.3360	0.3780
0.250	0.1229	0.1305	0.1310	0.1352	0.1509	0.1619
0.350	0.1008	0.1048	0.1030	0.1025	0.1082	0.1136
0.475	0.08611	0.08909	0.08664	0.08483	0.08695	0.08968
0.650	0.07396	0.07612	0.07357	0.07141	0.07172	0.07333
0.825	0.06580	0.06766	0.06539	0.06319	0.06306	0.06422
1.000	0.05980	0.06140	0.05930	0.05720	0.05690	0.05790
1.225	0.05393	0.05535	0.05339	0.05148	0.05107	0.05190
1.475	0.04911	0.05041	0.04860	0.04688	0.04648	0.04718
1.700	0.04583	0.04708	0.04540	0.04382	0.04349	0.04418
1.900	0.04351	0.04472	0.04316	0.04170	0.04146	0.04215
2.100	0.04158	0.04277	0.04133	0.03999	0.03983	0.04054
2.300	0.03996	0.04115	0.03982	0.03860	0.03851	0.03924
2.500	0.03859	0.03978	0.03856	0.03744	0.03743	0.03818
2.700	0.03743	0.03862	0.03750	0.03648	0.03654	0.03731
3.000	0.03600	0.03720	0.03620	0.03530	0.03550	0.03630
3.600	0.03396	0.03520	0.03435	0.03364	0.03414	0.03500
4.500	0.03208	0.03351	0.03273	0.03225	0.03318	0.03413
5.500	0.03089	0.03239	0.03184	0.03149	0.03270	0.03375
6.600	0.03016	0.03170	0.03141	0.03122	0.03263	0.03380
8.600	0.02958	0.03135	0.03118	0.03136	0.03318	0.03452

Mass Attenuation Coefficients, cm²/g

Energy meV	RHODIUM	SILVER	TIN	CESIUM	PROMETHIUM	ERBIUM
	Zb= 45.00	Zb= 47.00	Zb= 50.00	Zb= 55.00	Zb= 61.00	Zb= 68.00
	Za= 45.00	Za= 47.00	Za= 50.00	Za= 55.00	Za= 61.00	Za= 68.00
	AW=102.91	AW=107.87	AW=118.71	AW=132.91	AW=147.00	AW=167.26
0.015	29.20	33.40	39.10	51.80	71.00	95.80
0.025	54.38	7.930	9.393	12.39	16.90	23.02
0.035	22.10	24.68	28.36	4.878	6.698	9.078
0.045	11.00	12.31	13.92	17.01	3.381	4.587
0.055	6.367	7.141	8.156	10.11	12.90	2.679
0.065	4.066	4.572	5.218	6.583	8.518	9.640
0.075	2.756	3.103	3.545	4.512	5.913	7.235
0.085	1.981	2.224	2.534	3.234	4.264	5.571
0.095	1.492	1.666	1.888	2.406	3.175	4.135
0.150	0.4870	0.5360	0.6000	0.7430	0.9610	1.240
0.250	0.1876	0.2002	0.2147	0.2529	0.3105	0.3796
0.350	0.1234	0.1291	0.1333	0.1478	0.1715	0.2023
0.475	0.09423	0.09623	0.09681	0.1023	0.1131	0.1259
0.650	0.07540	0.07625	0.07551	0.07786	0.08349	0.08960
0.825	0.06542	0.06589	0.06475	0.06573	0.06912	0.07245
1.000	0.05860	0.05890	0.05760	0.05810	0.06050	0.06260
1.225	0.05241	0.05252	0.05127	0.05145	0.05313	0.05439
1.475	0.04768	0.04769	0.04657	0.04658	0.04790	0.04872
1.700	0.04467	0.04469	0.04368	0.04364	0.04490	0.04560
1.900	0.04264	0.04271	0.04178	0.04176	0.04304	0.04373
2.100	0.04105	0.04118	0.04031	0.04034	0.04165	0.04237
2.300	0.03980	0.03997	0.03914	0.03926	0.04057	0.04137
2.500	0.03880	0.03902	0.03822	0.03842	0.03975	0.04061
2.700	0.03800	0.03825	0.03750	0.03778	0.03913	0.04006
3.000	0.03710	0.03740	0.03670	0.03710	0.03850	0.03950
3.600	0.03605	0.03641	0.03583	0.03642	0.03799	0.03908
4.500	0.03549	0.03594	0.03554	0.03639	0.03824	0.03965
5.500	0.03535	0.03591	0.03572	0.03684	0.03900	0.04072
6.600	0.03561	0.03625	0.03620	0.03747	0.03988	0.04174
8.600	0.03675	0.03747	0.03752	0.03901	0.04169	0.04378

Mass Attenuation Coefficients, cm²/g

Energy meV	TUNGSTEN	IRIDIUM	GOLD	LEAD	RADIUM	THORIUM
	Zb= 74.00	Zb= 77.00	Zb= 79.00	Zb= 82.00	Zb= 88.00	Zb= 90.00
	Za= 74.00	Za= 77.00	Za= 79.00	Za= 82.00	Za= 88.00	Za= 90.00
	AW=183.85	AW=192.22	AW=196.97	AW=207.20	AW=226.00	AW=232.04
0.015	121.00	133.00	143.00	117.00	35.50	37.70
0.025	29.24	32.62	35.36	38.99	47.36	49.64
0.035	11.61	12.81	13.83	15.24	18.41	19.57
0.045	5.854	6.496	7.031	7.602	9.145	9.741
0.055	3.385	3.763	3.989	4.458	5.316	5.674
0.065	2.174	2.393	2.783	2.876	3.426	3.646
0.075	9.078	1.660	2.027	1.969	2.357	2.496
0.085	6.607	7.148	7.706	1.414	1.719	1.807
0.095	4.966	5.410	5.789	6.232	1.292	1.361
0.150	1.520	1.660	1.770	1.920	2.250	2.360
0.250	0.4511	0.4869	0.5188	0.5574	0.6426	0.6766
0.350	0.2321	0.2491	0.2626	0.2795	0.3197	0.3344
0.475	0.1415	0.1487	0.1563	0.1655	0.1856	0.1933
0.650	0.09708	0.1006	0.1048	0.1081	0.1191	0.1233
0.825	0.07675	0.07908	0.08152	0.08410	0.09025	0.09268
1.000	0.06550	0.06690	0.06860	0.07020	0.07440	0.07610
1.225	0.05642	0.05723	0.05847	0.05948	0.06230	0.06345
1.475	0.05026	0.05087	0.05188	0.05260	0.05465	0.05547
1.700	0.04686	0.04745	0.04840	0.04894	0.05071	0.05138
1.900	0.04486	0.04546	0.04638	0.04681	0.04846	0.04907
2.100	0.04346	0.04405	0.04494	0.04532	0.04687	0.04746
2.300	0.04246	0.04303	0.04388	0.04426	0.04571	0.04631
2.500	0.04176	0.04229	0.04311	0.04352	0.04488	0.04550
2.700	0.04126	0.04177	0.04257	0.04302	0.04433	0.04495
3.000	0.04080	0.04130	0.04210	0.04260	0.04390	0.04450
3.600	0.04054	0.04110	0.04196	0.04254	0.04396	0.04443
4.500	0.04114	0.04177	0.04268	0.04324	0.04447	0.04483
5.500	0.04226	0.04281	0.04370	0.04413	0.04525	0.04576
6.600	0.04340	0.04392	0.04485	0.04528	0.04653	0.04714
8.600	0.04567	0.04644	0.04745	0.04810	0.04945	0.04993

Mass Attenuation Coefficients, cm^2/g

Energy meV	URANIUM	PLUTONIUM	CURIUM
	Zb= 92.0	Zb= 94.0	Zb= 96.0
	Za= 92.0	Za= 94.0	Za= 96.0
	AW= 238.0	AW= 239.0	AW= 245.0
0.015	40.20	43.60	48.00
0.025	52.60	57.29	61.89
0.035	20.73	22.29	24.07
0.045	10.37	11.15	12.01
0.055	5.997	6.425	6.899
0.065	3.820	4.097	4.382
0.075	2.632	2.822	3.015
0.085	1.909	2.045	2.178
0.095	1.436	1.538	1.631
0.150	2.490	2.650	2.770
0.250	0.7067	0.7640	0.8199
0.350	0.3506	0.3740	0.3956
0.475	0.2012	0.2144	0.2265
0.650	0.1276	0.1346	0.1403
0.825	0.09532	0.1004	0.1042
1.000	0.07800	0.08160	0.08480
1.225	0.06479	0.06796	0.06982
1.475	0.05640	0.05934	0.06037
1.700	0.05209	0.05456	0.05561
1.900	0.04973	0.05174	0.05298
2.100	0.04824	0.04985	0.05118
2.300	0.04730	0.04860	0.04991
2.500	0.04668	0.04777	0.04900
2.700	0.04625	0.04721	0.04838
3.000	0.04580	0.04670	0.04780
3.600	0.04520	0.04634	0.04745
4.500	0.04533	0.04669	0.04769
5.500	0.04639	0.04756	0.04843
6.600	0.04770	0.04890	0.04986
8.600	0.05044	0.05209	0.05322

Zb = Effective atomic number used for bremsstrahlung production

Za = Effective atomic number in the buildup factor calculation

AW = Effective atomic weight to estimate the atom density of atoms with the effective atomic number given by Za

APPENDIX B

VALUES FOR BUILDUP FACTOR COEFFICIENTS

This page intentionally left blank.

Low Energy Buildup Factor Tables - by Energy

0.01 meV	1.0	2.0	4.0	7.0	10.0	15.0	20.0
Z = 3.3	1.200	5.000	18.000	47.000	86.000	160.000	580.000
Z = 13.0	1.007	1.014	1.027	1.043	1.058	1.078	1.095
Z = 26.0	1.001	1.002	1.004	1.006	1.008	1.011	1.013
Z = 50.0	1.002	1.003	1.006	1.009	1.012	1.016	1.021
Z = 74.0	1.001	1.001	1.002	1.004	1.005	1.006	1.008
Z = 82.0	1.000	1.001	1.002	1.003	1.004	1.005	1.006
Z = 92.0	1.000	1.001	1.001	1.002	1.003	1.004	1.004

0.02 meV	1.0	2.0	4.0	7.0	10.0	15.0	20.0
Z = 3.3	1.400	6.600	24.000	64.000	140.000	310.000	1000.000
Z = 13.0	1.058	1.110	1.210	1.340	1.450	1.590	1.720
Z = 26.0	1.007	1.013	1.024	1.037	1.047	1.060	1.070
Z = 50.0	1.009	1.017	1.031	1.048	1.062	1.080	1.094
Z = 74.0	1.003	1.006	1.012	1.018	1.023	1.030	1.035
Z = 82.0	1.002	1.005	1.009	1.013	1.017	1.022	1.026
Z = 92.0	1.002	1.004	1.006	1.010	1.013	1.017	1.020

0.05 meV	1.0	2.0	4.0	7.0	10.0	15.0	20.0
Z = 3.3	2.300	9.700	36.000	100.000	360.000	1500.000	4300.000
Z = 13.0	2.060	3.190	4.870	9.390	14.300	24.000	34.800
Z = 26.0	1.086	1.160	1.270	1.390	1.480	1.600	1.700
Z = 50.0	1.013	1.023	1.038	1.054	1.065	1.078	1.089
Z = 74.0	1.030	1.054	1.090	1.130	1.160	1.190	1.220
Z = 82.0	1.022	1.039	1.066	1.093	1.110	1.140	1.160
Z = 92.0	1.016	1.029	1.048	1.069	1.083	1.100	1.120

0.10 meV	1.0	2.0	4.0	7.0	10.0	15.0	20.0
Z = 3.3	3.650	11.000	43.000	130.000	700.000	4800.000	19000.00
Z = 13.0	2.820	5.640	12.900	40.600	91.000	245.000	457.000
Z = 26.0	1.350	1.670	2.280	3.070	3.830	5.040	6.250
Z = 50.0	1.054	1.093	1.150	1.200	1.250	1.300	1.350
Z = 74.0	1.019	1.033	1.052	1.073	1.090	1.120	1.150
Z = 82.0	1.018	1.033	1.062	1.100	1.140	1.220	1.300
Z = 92.0	1.058	1.100	1.160	1.230	1.280	1.340	1.390

0.20 meV	1.0	2.0	4.0	7.0	10.0	15.0	20.0
Z = 3.3	3.200	8.000	27.000	89.000	280.000	1050.000	2700.000
Z = 13.0	2.710	5.350	13.200	45.300	117.000	345.000	718.000
Z = 26.0	1.710	2.620	4.880	9.250	14.800	24.200	37.300
Z = 50.0	1.200	1.350	1.580	1.870	2.110	2.460	2.760
Z = 74.0	1.073	1.120	1.190	1.260	1.320	1.390	1.450
Z = 82.0	1.055	1.091	1.140	1.200	1.230	1.290	1.330
Z = 92.0	1.042	1.069	1.110	1.150	1.180	1.230	1.280

Low Energy Buildup Factor Tables - by Atomic Number

Z = 3.33	1.0	2.0	4.0	7.0	10.0	15.0	20.0
0.01 meV	1.200	5.000	18.000	47.000	86.000	160.000	580.000
0.02 meV	1.400	6.600	24.000	64.000	140.000	310.000	1000.000
0.05 meV	2.300	9.700	36.000	100.000	360.000	1500.000	4300.000
0.10 meV	3.650	11.000	43.000	130.000	700.000	4800.000	19000.00
0.20 meV	3.200	8.000	27.000	89.000	280.000	1050.000	2700.000

Z = 13.0	1.0	2.0	4.0	7.0	10.0	15.0	20.0
0.01 meV	1.007	1.014	1.027	1.043	1.058	1.078	1.095
0.02 meV	1.058	1.110	1.210	1.340	1.450	1.590	1.720
0.05 meV	2.060	3.190	4.870	9.390	14.300	24.000	34.800
0.10 meV	2.820	5.640	12.900	40.600	91.000	245.000	457.000
0.20 meV	2.710	5.350	13.200	45.300	117.000	345.000	718.000

Z = 26.0	1.0	2.0	4.0	7.0	10.0	15.0	20.0
0.01 meV	1.001	1.002	1.004	1.006	1.008	1.011	1.013
0.02 meV	1.007	1.013	1.024	1.037	1.047	1.060	1.070
0.05 meV	1.086	1.160	1.270	1.390	1.480	1.600	1.700
0.10 meV	1.350	1.670	2.280	3.070	3.830	5.040	6.250
0.20 meV	1.710	2.620	4.880	9.250	14.800	24.200	37.300

Z = 50.0	1.0	2.0	4.0	7.0	10.0	15.0	20.0
0.01 meV	1.002	1.003	1.006	1.009	1.012	1.016	1.021
0.02 meV	1.009	1.017	1.031	1.048	1.062	1.080	1.094
0.05 meV	1.013	1.023	1.038	1.054	1.065	1.078	1.089
0.10 meV	1.054	1.093	1.150	1.200	1.250	1.300	1.350
0.20 meV	1.200	1.350	1.580	1.870	2.110	2.460	2.760

Z = 74.0	1.0	2.0	4.0	7.0	10.0	15.0	20.0
0.01 meV	1.001	1.001	1.002	1.004	1.005	1.006	1.008
0.02 meV	1.003	1.006	1.012	1.018	1.023	1.030	1.035
0.05 meV	1.030	1.054	1.090	1.130	1.160	1.190	1.220
0.10 meV	1.019	1.033	1.052	1.073	1.090	1.120	1.150
0.20 meV	1.073	1.120	1.190	1.260	1.320	1.390	1.450

Z = 82.0	1.0	2.0	4.0	7.0	10.0	15.0	20.0
0.01 meV	1.000	1.001	1.002	1.003	1.004	1.005	1.006
0.02 meV	1.002	1.005	1.009	1.013	1.017	1.022	1.026
0.05 meV	1.022	1.039	1.066	1.093	1.110	1.140	1.160
0.10 meV	1.018	1.033	1.062	1.100	1.140	1.220	1.300
0.20 meV	1.055	1.091	1.140	1.200	1.230	1.290	1.330

WHC-SD-WM-UM-030
Revision 0

Z = 92.0	1.0	2.0	4.0	7.0	10.0	15.0	20.0
0.01 meV	1.000	1.001	1.001	1.002	1.003	1.004	1.004
0.02 meV	1.002	1.004	1.006	1.010	1.013	1.017	1.020
0.05 meV	1.016	1.029	1.048	1.069	1.083	1.100	1.120
0.10 meV	1.058	1.100	1.160	1.230	1.280	1.340	1.390
0.20 meV	1.042	1.069	1.110	1.150	1.180	1.230	1.280

Taylor Coefficient Tables - by Atomic Number

Energy meV	Atomic Number = 3.33			Atomic Number = 13.0		
	A	a1	a2	A	a1	a2
0.150	33.000	-0.2350	-0.1600	28.000	-0.1600	-0.1100
0.250	30.000	-0.2000	-0.1200	22.000	-0.1500	-0.0700
0.350	27.399	-0.1691	-0.0822	16.527	-0.1406	-0.0352
0.475	23.782	-0.1419	-0.0457	11.985	-0.1314	-0.0037
0.650	18.306	-0.1221	-0.0133	9.417	-0.1231	0.0211
0.825	13.895	-0.1115	0.0098	8.543	-0.1165	0.0352
1.000	11.000	-0.1040	0.0300	8.000	-0.1100	0.0450
1.225	9.048	-0.0958	0.0534	7.266	-0.1015	0.0553
1.475	7.892	-0.0882	0.0725	6.553	-0.0933	0.0675
1.700	7.135	-0.0825	0.0831	6.081	-0.0875	0.0797
1.900	6.610	-0.0780	0.0894	5.749	-0.0836	0.0892
2.100	6.223	-0.0741	0.0944	5.458	-0.0806	0.0961
2.300	5.937	-0.0705	0.0986	5.196	-0.0783	0.1009
2.500	5.700	-0.0675	0.1020	4.965	-0.0763	0.1050
2.700	5.483	-0.0650	0.1047	4.764	-0.0744	0.1093
3.000	5.200	-0.0620	0.1080	4.500	-0.0720	0.1160
3.600	4.766	-0.0580	0.1140	4.048	-0.0691	0.1287
4.500	4.165	-0.0539	0.1193	3.545	-0.0668	0.1400
5.500	3.736	-0.0504	0.1226	3.159	-0.0648	0.1484
6.600	3.410	-0.0476	0.1255	2.823	-0.0633	0.1543
8.600	2.884	-0.0440	0.1287	2.407	-0.0614	0.1443

Energy meV	Atomic Number = 26.0			Atomic Number = 50.0		
	A	a1	a2	A	a1	a2
0.150	11.300	-0.0990	-0.0050	2.600	-0.0586	0.1040
0.250	10.900	-0.0976	0.0010	3.100	-0.0600	0.1100
0.350	10.527	-0.0966	0.0055	3.542	-0.0610	0.1139
0.475	10.085	-0.0953	0.0106	3.941	-0.0623	0.1189
0.650	9.522	-0.0933	0.0175	4.244	-0.0640	0.1265
0.825	9.030	-0.0908	0.0235	4.371	-0.0660	0.1321
1.000	8.600	-0.0880	0.0285	4.400	-0.0680	0.1350
1.225	8.113	-0.0840	0.0338	4.357	-0.0707	0.1360
1.475	7.601	-0.0798	0.0391	4.261	-0.0737	0.1373
1.700	7.149	-0.0765	0.0436	4.157	-0.0763	0.1395
1.900	6.773	-0.0743	0.0473	4.054	-0.0787	0.1404
2.100	6.436	-0.0729	0.0506	3.944	-0.0813	0.1390
2.300	6.121	-0.0723	0.0535	3.828	-0.0839	0.1359
2.500	5.800	-0.0720	0.0562	3.710	-0.0865	0.1325
2.700	5.466	-0.0719	0.0587	3.590	-0.0890	0.1294
3.000	5.000	-0.0720	0.0620	3.400	-0.0930	0.1250
3.600	4.321	-0.0730	0.0660	2.980	-0.1028	0.1142
4.500	3.688	-0.0754	0.0669	2.375	-0.1192	0.0917
5.500	3.263	-0.0788	0.0629	1.882	-0.1362	0.0646
6.600	2.911	-0.0825	0.0527	1.506	-0.1529	0.0312
8.600	2.339	-0.0896	0.0272	1.036	-0.1753	0.0168

Values* were modified to produce smooth curves when plotted against photon energy.

*Source: H. Goldstein, 1959, *Fundamental Aspects of Reactor Shielding*, Addison-Wesley Publishing Co., Inc., Reading, Massachusetts.

Taylor Coefficient Tables - by Atomic Number

Energy meV	Atomic Number = 74.0			Atomic Number = 82.0		
	A	a1	a2	A	a1	a2
0.150	3.470	0.0476	0.0840	1.120	-0.0200	0.6200
0.250	3.450	0.0300	0.0950	1.300	-0.0240	0.5000
0.350	3.429	0.0165	0.1034	1.414	-0.0271	0.3898
0.475	3.404	0.0018	0.1131	1.603	-0.0307	0.2934
0.650	3.375	-0.0162	0.1260	1.955	-0.0356	0.2280
0.825	3.341	-0.0301	0.1374	2.255	-0.0403	0.1976
1.000	3.300	-0.0400	0.1470	2.450	-0.0450	0.1780
1.225	3.240	-0.0484	0.1577	2.568	-0.0509	0.1572
1.475	3.167	-0.0554	0.1697	2.617	-0.0574	0.1369
1.700	3.100	-0.0610	0.1806	2.631	-0.0632	0.1207
1.900	3.035	-0.0657	0.1864	2.617	-0.0684	0.1088
2.100	2.963	-0.0703	0.1860	2.576	-0.0736	0.0999
2.300	2.887	-0.0747	0.1799	2.509	-0.0788	0.0934
2.500	2.810	-0.0790	0.1700	2.420	-0.0840	0.0880
2.700	2.733	-0.0832	0.1575	2.314	-0.0893	0.0832
3.000	2.600	-0.0900	0.1360	2.150	-0.0970	0.0770
3.600	2.267	-0.1064	0.0924	1.856	-0.1121	0.0680
4.500	1.815	-0.1323	0.0508	1.441	-0.1378	0.0607
5.500	1.393	-0.1589	0.0132	1.082	-0.1643	0.0585
6.600	0.999	-0.1842	0.0038	0.848	-0.1861	0.0605
8.600	0.645	-0.2088	0.0795	0.613	-0.2082	0.0708

Energy meV	Atomic Number = 92.0		
	A	a1	a2
0.150	0.930	-0.0270	0.4000
0.250	1.090	-0.0280	0.3950
0.350	1.225	-0.0288	0.3896
0.475	1.371	-0.0298	0.3818
0.650	1.579	-0.0314	0.3671
0.825	1.793	-0.0332	0.3446
1.000	2.000	-0.0350	0.3100
1.225	2.241	-0.0371	0.2467
1.475	2.478	-0.0397	0.1775
1.700	2.671	-0.0427	0.1408
1.900	2.827	-0.0456	0.1243
2.100	2.968	-0.0484	0.1114
2.300	3.073	-0.0510	0.0979
2.500	3.100	-0.0540	0.0860
2.700	3.024	-0.0576	0.0776
3.000	2.800	-0.0640	0.0700
3.600	2.353	-0.0782	0.0609
4.500	1.831	-0.1041	0.0532
5.500	1.390	-0.1355	0.0473
6.600	0.999	-0.1654	0.0430
8.600	0.553	-0.1992	0.0435

Values* were modified to produce smooth curves when plotted against photon energy.

*Source: H. Goldstein, 1959, *Fundamental Aspects of Reactor Shielding*, Addison-Wesley Publishing Co., Inc., Reading, Massachusetts.

This page intentionally left blank.

APPENDIX C

VALUES FOR FLUENCE-TO DOSE CONVERSIONS

This page intentionally left blank.

Fluence-to-Dose Factors Used

Energy meV	Exposure R/h per meV/cm ² /s	----- Dose Equivalent, rem/h per meV/cm ² /s -----					Original ANSI '77
		Frontal AP	Rear PA	Side LAT	All Sides ROT	Any Dir ISO	
0.015	8.183E-05	3.87E-06	7.54E-07	7.83E-07	1.72E-06	1.42E-06	1.30E-04
0.025	1.656E-05	4.15E-06	1.90E-06	9.83E-07	2.02E-06	1.66E-06	3.20E-05
0.035	6.084E-06	3.52E-06	2.04E-06	1.08E-06	1.87E-06	1.52E-06	1.25E-05
0.045	3.203E-06	2.98E-06	1.90E-06	1.09E-06	1.69E-06	1.36E-06	7.05E-06
0.055	2.216E-06	2.60E-06	1.76E-06	1.06E-06	1.54E-06	1.25E-06	4.98E-06
0.065	1.827E-06	2.34E-06	1.65E-06	1.02E-06	1.43E-06	1.16E-06	3.99E-06
0.075	1.664E-06	2.15E-06	1.58E-06	9.82E-07	1.35E-06	1.10E-06	3.44E-06
0.085	1.603E-06	2.03E-06	1.53E-06	9.49E-07	1.30E-06	1.07E-06	3.11E-06
0.095	1.592E-06	1.94E-06	1.51E-06	9.24E-07	1.27E-06	1.04E-06	2.90E-06
0.150	1.728E-06	1.80E-06	1.50E-06	9.53E-07	1.29E-06	1.05E-06	2.53E-06
0.250	1.935E-06	1.87E-06	1.55E-06	1.04E-06	1.35E-06	1.11E-06	2.52E-06
0.350	2.019E-06	1.87E-06	1.57E-06	1.10E-06	1.38E-06	1.15E-06	2.51E-06
0.475	2.043E-06	1.84E-06	1.58E-06	1.13E-06	1.40E-06	1.18E-06	2.35E-06
0.650	2.029E-06	1.77E-06	1.56E-06	1.16E-06	1.40E-06	1.19E-06	2.22E-06
0.825	1.983E-06	1.71E-06	1.53E-06	1.17E-06	1.38E-06	1.19E-06	2.09E-06
1.000	1.923E-06	1.65E-06	1.50E-06	1.16E-06	1.35E-06	1.17E-06	1.98E-06
1.225	1.850E-06	1.57E-06	1.45E-06	1.15E-06	1.31E-06	1.15E-06	1.87E-06
1.475	1.775E-06	1.50E-06	1.40E-06	1.13E-06	1.27E-06	1.13E-06	1.77E-06
1.700	1.712E-06	1.45E-06	1.36E-06	1.11E-06	1.23E-06	1.10E-06	1.69E-06
1.900	1.660E-06	1.41E-06	1.32E-06	1.09E-06	1.20E-06	1.08E-06	1.63E-06
2.100	1.613E-06	1.37E-06	1.29E-06	1.08E-06	1.17E-06	1.06E-06	1.58E-06
2.300	1.592E-06	1.33E-06	1.26E-06	1.06E-06	1.15E-06	1.04E-06	1.53E-06
2.500	1.534E-06	1.30E-06	1.23E-06	1.05E-06	1.12E-06	1.02E-06	1.49E-06
2.700	1.499E-06	1.27E-06	1.21E-06	1.03E-06	1.10E-06	1.01E-06	1.45E-06
3.000	1.453E-06	1.23E-06	1.17E-06	1.01E-06	1.07E-06	9.82E-07	1.40E-06
3.600	1.375E-06	1.16E-06	1.11E-06	9.74E-07	1.02E-06	9.41E-07	1.31E-06
4.500	1.289E-06	1.09E-06	1.04E-06	9.29E-07	9.58E-07	8.94E-07	1.20E-06
5.500	1.223E-06	1.03E-06	9.87E-07	8.90E-07	9.11E-07	8.55E-07	1.13E-06
6.600	1.167E-06	9.77E-07	9.44E-07	8.59E-07	8.75E-07	8.24E-07	1.06E-06
8.600	1.098E-06	9.18E-07	8.95E-07	8.21E-07	8.39E-07	7.91E-07	9.85E-07

Derivation of Values:

Exposure (second column)¹--Values shown were obtained by cubic spline interpolation in log-log coordinates.

Original ANSI '77 (last column)--computed with formulas given in ANSI/ANS-6.4.3-1977.²

¹Goldstein, H., 1959, *Fundamental Aspects of Reactor Shielding*, table on page 17, Addison-Wesley Publishing Co., Inc., Reading, Massachusetts.

²ANSI/ANS, 1977, *American National Standard for Neutron and Gamma-Ray Flux-to-Dose-Rate Factors*, ANSI/ANS-6.1.1-1977, American Nuclear Society, La Grange Park, Illinois.

Frontal (AP) to Any Direction (ISO)--computed with formulas in
ANSI/ANS-6.4.3-1991.¹

¹ANSI/ANS, 1991, *American National Standard for Neutron and Gamma-Ray Fluence-to-Dose Factors*, ANSI/ANS-6.1.1-1991, American Nuclear Society, La Grange Park, Illinois.

APPENDIX D

LISTING OF THE NUCLIDES IN THE ISO-PC LIBRARY

This page intentionally left blank.

APPENDIX D

LISTING OF THE NUCLIDES IN THE ISO-PC LIBRARY

Two lists of the nuclides in ISO-PC.LIB are provided. The first is sorted by the atomic mass number (A) of the nuclide, and by atomic number (Z) for isotopes with the same atomic mass. The second is sorted alphabetically by the chemical symbol. The column headings are the following:

- A : Atomic mass number of the isotope
- Name : Chemical symbol for the element. Excited states are indicated with the letter "m" (i.e., metastable).
- rad : Types of radiation emitted. "b" means that beta energies are given in the beta library. "g" means that gamma (and x-ray) energies are given in the photon library. No entry in this column means the isotope is stable (it was needed by RIBD).
- Weight : The library number of the isotope. It is used to identify the isotopes in the namelist input. It is the array index for the WEIGHT variable in the namelist input.

ISOSHL Nuclide Library--Sorted by Atomic Mass Number

A	Name	rad	Weight	A	Name	rad	Weight	A	Name	rad	Weight
10	Be	b	6	77m	Se	g	20	87	Kr	b,g	65
14	C	b	451	78	Ge	b,g	22	87	Rb	b	66
16	N	b,g	452	78	As	b,g	23	87m	Sr	g	67
22	Na	b,g	529	78	Se		24	87	Sr		68
24	Na	b,g	453	79	As	b,g	25	88	Br	b,g	69
25	Na	b,g	454	79m	Se	g	26	88	Kr	b,g	70
27	Mg	b,g	455	79	Se	b	27	88	Rb	b,g	71
28	Al	b,g	456	79	Br		28	88	Sr		72
29	Al	b,g	457	80	As	b,g	29	89	Br	b	73
31	Si	b,g	458	80	Se		30	89	Kr	b,g	74
32	P	b	459	80m	Br	g	31	89	Rb	b,g	75
35	S	b	460	80	Br	b,g	32	89	Sr	b,g	76
36	Cl	b,g	3	80	Kr		33	89m	Y	g	77
40	K	b,g	521	81	As	b	34	89	Y		78
41	Ar	b,g	535	81m	Se	g	35	90	Br	b	79
45	Ca	b	461	81	Se	b,g	36	90	Kr	b,g	80
46	Sc	b,g	462	81	Br		37	90	Rb	b,g	81
47	Sc	b,g	463	81	Kr		38	90	Sr	b	82
51	Cr	g	464	82	Se		39	90m	Y	b,g	83
54	Mn	g	465	82	Br	b,g	40	90	Y	b,g	84
55	Cr	b	466	82	Kr		41	90	Zr		85
55	Fe		467	83m	Se	b,g	42	91	Kr	b	86
56	Cr	b,g	468	83	Se	b,g	43	91m	Rb	b	87
56	Mn	b,g	469	83	Br	b,g	44	91	Rb	b	88
57	Co	g	527	83m	Kr	g	45	91	Sr	b,g	89
58	Co	g	470	83	Kr		46	91m	Y	g	90
59	Fe	b,g	471	84	Se	b,g	47	91	Y	b,g	91
60	Co	b,g	472	84m	Br	b,g	48	91	Zr		92
64	Cu	b,g	473	84	Br	b,g	49	92	Kr	b	93
65	Zn	g	474	84	Kr		50	92	Rb	b	94
69	Zn	b	475	85	As	b	51	92	Sr	b,g	95
72	Zn	b,g	1	85	Se	b	52	92	Y	b,g	96
72	Ga	b,g	2	85	Br	b	53	92	Zr		97
73	Zn		4	85m	Kr	b,g	54	93	Kr	b	98
73	Ga	b,g	5	85	Kr	b,g	55	93	Rb	b	99
74	Ga	b,g	7	85	Rb		56	93	Sr	b,g	100
74	Ge		8	85m	Sr	g	532	93	Y	b,g	101
75	Ga	b,g	9	86	Se	b	57	93	Zr	b	102
75m	Ge	g	10	86	Br	b,g	58	93m	Nb	g	103
75	Ge	b,g	11	86	Kr		59	93	Nb		104
76	Ga	b,g	13	86m	Rb	g	60	94	Kr	b	105
76	As	b,g	15	86	Rb	b,g	61	94	Rb	b	106
77m	Ge	b,g	17	86	Sr		62	94	Sr	b,g	107
77	Ge	b,g	18	87	Se	b	63	94	Y	b,g	108
77	As	b,g	19	87	Br	b,g	64	94	Zr		109

ISOSHL Nuclide Library--Sorted by Atomic Mass Number

A	Name	rad	Weight	A	Name	rad	Weight	A	Name	rad	Weight
94m	Nb	b,g	110	103	Tc	b,g	154	111m	Cd	g	198
94	Nb	b,g	111	103	Ru	b,g	155	111	Cd		199
94	Mo		112	103m	Rh	g	156	112	Pd	b,g	200
95	Kr	b	113	103	Rh		157	112	Ag	b,g	201
95	Rb	b	114	104	Mo	b	158	112	Cd		202
95	Sr	b	115	104	Tc	b,g	159	113	Pd	b	203
95	Y	b,g	116	104	Ru		160	113m	Ag	b,g	204
95	Zr	b,g	117	104m	Rh	b,g	161	113	Ag	b,g	205
95m	Nb	b,g	118	104	Rh	b,g	162	113m	Cd	b,g	206
95	Nb	b,g	119	104	Pd		163	113	Cd	b	207
95	Mo		120	104	Cd	g	528	113	In		208
95	Tc	b,g	531	105	Mo	b	164	114	Pd	b	209
96	Y	b,g	121	105	Tc	b,g	165	114	Ag	b,g	210
96	Zr		122	105	Ru	b,g	166	114	Cd		211
96	Nb	b,g	123	105m	Rh	g	167	114m	In	g	212
96	Mo		124	105	Rh	b,g	168	114	In	b,g	213
97	Kr	b	125	105	Pd		169	115	Pd	b	214
97	Rb	b	126	106	Ru	b	170	115m	Ag	b	215
97	Sr	b	127	106m	Rh	b,g	171	115	Ag	b,g	216
97	Y	b	128	106	Rh	b,g	172	115m	Cd	b,g	217
97	Zr	b,g	129	106	Pd		173	115	Cd	b,g	218
97m	Nb	g	130	107	Tc	b	174	115m	In	b,g	219
97	Nb	b,g	131	107	Ru	b,g	175	115	In	b	220
97	Mo		132	107	Rh	b,g	176	115	Sn		221
98	Zr	b	133	107	Pd	b	177	116	Pd	b	222
98m	Nb	b	134	107	Ag		178	116	Ag	b,g	223
98	Nb	b,g	135	108	Ru	b,g	179	116	Cd		224
98	Mo		136	108	Rh	b,g	180	116m	In	b,g	225
99	Zr	b	137	108	Pd		181	116	In	b,g	226
99	Nb	b,g	138	108m	Ag	g	182	116	Sn		227
99	Mo	b,g	139	108	Ag	b,g	183	117	Ag	b	228
99m	Tc	g	140	108	Cd		184	117m	Cd	b,g	229
99	Tc	b	141	109	Rh	b	185	117	Cd	b,g	230
99	Ru		142	109m	Pd	g	186	117m	In	b,g	231
100	Nb	b,g	143	109	Pd	b,g	187	117	In	b,g	232
100	Mo		144	109m	Ag	b,g	188	117m	Sn	g	233
100	Tc	b,g	145	109	Cd	b,g	189	117	Sn		234
100	Ru		146	110	Pd		190	118	Cd	b	235
101	Nb	b	147	110m	Ag	b,g	191	118	In	b,g	236
101	Mo	b,g	148	110	Ag	b,g	192	118	Sn		237
101	Tc	b,g	149	110	Cd		193	119m	Cd	b	238
101	Ru		150	111m	Pd	b,g	194	119	Cd	b,g	239
102	Mo	b	151	111	Pd	b,g	195	119m	In	b,g	240
102	Tc	b,g	152	111m	Ag	g	196	119	In	b,g	241
102	Ru		153	111	Ag	b,g	197	119m	Sn	g	242

ISOSHLD Nuclide Library--Sorted by Atomic Mass Number

A	Name	rad	Weight	A	Name	rad	Weight	A	Name	rad	Weight
119	Sn		243	129m	Te	b,g	288	137	I	b	333
120	In	b,g	244	129	Te	b,g	289	137	Xe	b,g	334
120	Sn		245	129	I	b,g	290	137	Cs	b	335
121	Cd	b	246	129	Xe		291	137m	Ba	g	336
121m	In	b	247	130	Sn	b	292	137	Ba		337
121	In	b,g	248	130	Sb	b,g	293	138	I	b	338
121m	Sn	b,g	249	130	Te		294	138	Xe	b,g	339
121	Sn	b	250	130	I	b,g	295	138	Cs	b,g	340
121	Sb		251	130	Xe		296	138	Ba		341
122	In	b,g	252	131	Sb	b,g	297	139	I	b	342
122	Sn		253	131m	Te	b,g	298	139	Xe	b,g	343
122m	Sb	g	254	131	Te	b,g	299	139	Cs	b,g	344
122	Sb	b,g	255	131	I	b,g	300	139	Ba	b,g	345
122	Te		256	131m	Xe	g	301	139	La		346
123	In	b,g	257	131	Xe		302	140	Xe	b,g	347
123m	Sn	b,g	258	132	Sb	b	303	140	Cs	b,g	348
123	Sn	b,g	259	132	Te	b,g	304	140	Ba	b,g	349
123	Sb		260	132	I	b,g	305	140	La	b,g	350
123m	Te	g	261	132	Xe		306	140	Ce		351
123	Te		262	133	Sb	b	307	141	Xe	b	352
124	Sn		263	133m	Te	b,g	308	141	Cs	b	353
124m	Sb	b,g	264	133	Te	b,g	309	141	Ba	b,g	354
124	Sb	b,g	265	133	I	b,g	310	141	La	b,g	355
124	Te		266	133m	Xe	g	311	141	Ce	b,g	356
125m	Sn	b,g	267	133	Xe	b,g	312	141	Pr		357
125	Sn	b,g	268	133	Cs		313	142	Xe	b,g	358
125	Sb	b,g	269	133	Ba	b,g	320	142	Cs	b	359
125m	Te	b,g	270	134	Sb	b	314	142	Ba	b,g	360
125	Te		271	134	Te	b,g	315	142	La	b,g	361
126	Sn	b,g	272	134	I	b,g	316	142	Ce		362
126m	Sb	b,g	273	134	Xe		317	142	Pr	b,g	363
126	Sb	b,g	274	134m	Cs	b,g	318	142	Nd		364
126	Te		275	134	Cs	b,g	319	143	Xe	b	365
127	Sn	b,g	276	135	Sb	b	321	143	Cs	b	366
127	Sb	b,g	277	135	Te	b	322	143	Ba	b	367
127m	Te	b,g	278	135	I	b,g	323	143	La	b,g	368
127	Te	b,g	279	135m	Xe	g	324	143	Ce	b,g	369
127	I		280	135	Xe	b,g	325	143	Pr	b	370
128	Sn	b,g	281	135	Cs	b	326	143	Nd		371
128m	Sb	b,g	282	135m	Ba	g	327	144	Xe	b	372
128	Sb	b,g	283	135	Ba		328	144	Cs	b	373
128	Te		284	136	I	b,g	329	144	Ba	b	374
128	I	b,g	285	136	Xe		330	144	La	b	375
128	Xe		286	136	Cs	b,g	331	144	Ce	b,g	376
129	Sb	b,g	287	136	Ba		332	144	Pr	b,g	377

ISOSHL Nuclide Library--Sorted by Atomic Mass Number

A	Name	rad	Weight	A	Name	rad	Weight	A	Name	rad	Weight
144	Nd		378	156	Eu	b,g	421	222	Rn	g	514
145	Ce	b,g	379	156	Gd		422	224	Ra	b,g	522
145	Pr	b,g	380	157	Eu	b,g	423	225	Ra	b,g	515
145	Nd		381	157	Gd		424	225	Ac	g	516
146	Ce	b,g	382	158	Eu	b,g	425	226	Ra	b,g	485
146	Pr	b,g	383	158	Gd		426	227	Ra	b,g	486
146	Nd		384	159	Eu	b,g	427	227	Ac	b,g	487
146	Pm	b,g	477	159	Gd	b,g	428	228	Ra	b,g	488
147	Ce	b	385	159	Tb		429	228	Th	b,g	442
147	Pr	b,g	386	160	Eu	b	430	229	Th	g	517
147	Nd	b,g	387	160	Gd		431	230	Th	g	518
147	Pm	b,g	388	160	Tb	b,g	432	231	Th	b,g	450
147	Sm		389	160	Dy		433	233	Th	b,g	489
148	Ce	b	390	161	Gd	b,g	434	233	Pa	b,g	490
148	Pr	b,g	391	161	Tb	b,g	435	233	U	g	519
148	Nd		392	161	Dy		436	234	Th	b,g	530
148 ^m	Pm	b,g	393	162	Gd	b,g	437	234	Pa	b,g	441
148	Pm	b,g	394	162	Tb	b,g	438	234 ^m	Pa	b,g	533
148	Sm		395	162	Dy		439	234	U	b,g	520
149	Nd	b,g	396	163	Tb	b,g	440	235	U	b,g	476
149	Pm	b,g	397	165 ^m	Dy	b,g	443	237	U	b,g	491
149	Sm		398	165	Dy	b,g	444	237	Np	b,g	502
150	Nd		399	165	Ho		445	238	U	b,g	526
150	Eu	g	400	166	Dy	b,g	446	238	Pu	g	492
151	Nd	b,g	401	166	Ho	b,g	447	239	Np	g	503
151	Pm	b,g	402	166 ^m	Ho	b,g	448	239	Pu	g	493
151	Sm	b,g	403	167 ^m	Er	g	449	240	Pu	g	494
151	Eu		404	182	Ta	b,g	501	241	Pu	b,g	495
152	Pm	b,g	405	187	W	b,g	478	241	Am	b,g	496
152	Sm		406	198	Au	b,g	479	242	Pu	g	497
152 ^m	Eu	b,g	407	203	Hg	b,g	480	242 ^m	Am	g	498
152	Eu	b,g	408	205	Hg	b,g	481	242	Am	b,g	499
152	Gd		409	209	Pb	b	482	242	Cm	g	504
153	Pm	b,g	410	210	Tl	b,g	484	243	Am	g	505
153	Sm	b,g	411	210	Pb	b,g	508	243	Cm	g	506
153	Eu		412	210	Bi	b	483	244	Cm	g	500
154	Pm	b	413	212	Pb	b,g	524	245	Cm	g	507
154	Sm		414	212	Bi	b	525	246	Cm	g	534
154	Eu	b,g	415	213	Bi	b,g	509	270	Jc	b	12
154	Gd		416	214	Pb	b,g	510	271	Jc	b,g	14
155	Sm	b,g	417	214	Bi	b,g	511	272	Jc	b,g	16
155	Eu	b,g	418	214	Po	g	512	273	Jc	b,g	21
155	Gd		419	220	Rn	g	523				
156	Sm	b,g	420	221	Fr	g	513				

ISOSHLD Nuclide Library--Sorted Alphabetically

A	Name	rad	Weight	A	Name	rad	Weight	A	Name	rad	Weight
225	Ac	g	516	144	Ba	b	374	144	Ce	b,g	376
227	Ac	b,g	487	10	Be	b	6	145	Ce	b,g	379
107	Ag		178	210	Bi	b	483	146	Ce	b,g	382
108m	Ag	g	182	212	Bi	b	525	147	Ce	b	385
108	Ag	b,g	183	213	Bi	b,g	509	148	Ce	b	390
109m	Ag	b,g	188	214	Bi	b,g	511	36	Cl	b,g	3
110m	Ag	b,g	191	79	Br		28	242	Cm	g	504
110	Ag	b,g	192	80m	Br	g	31	243	Cm	g	506
111m	Ag	g	196	80	Br	b,g	32	244	Cm	g	500
111	Ag	b,g	197	81	Br		37	245	Cm	g	507
112	Ag	b,g	201	82	Br	b,g	40	246	Cm	g	534
113m	Ag	b,g	204	83	Br	b,g	44	57	Co	g	527
113	Ag	b,g	205	84m	Br	b,g	48	58	Co	g	470
114	Ag	b,g	210	84	Br	b,g	49	60	Co	b,g	472
115m	Ag	b	215	85	Br	b	53	51	Cr	g	464
115	Ag	b,g	216	86	Br	b,g	58	55	Cr	b	466
116	Ag	b,g	223	87	Br	b,g	64	56	Cr	b,g	468
117	Ag	b	228	88	Br	b,g	69	133	Cs		313
28	Al	b,g	456	89	Br	b	73	134m	Cs	b,g	318
29	Al	b,g	457	90	Br	b	79	134	Cs	b,g	319
241	Am	b,g	496	14	C	b	451	135	Cs	b	326
242m	Am	g	498	45	Ca	b	461	136	Cs	b,g	331
242	Am	b,g	499	104	Cd	g	528	137	Cs	b	335
243	Am	g	505	108	Cd		184	138	Cs	b,g	340
41	Ar	b,g	535	109	Cd	b,g	189	139	Cs	b,g	344
76	As	b,g	15	110	Cd		193	140	Cs	b,g	348
77	As	b,g	19	111m	Cd	g	198	141	Cs	b	353
78	As	b,g	23	111	Cd		199	142	Cs	b	359
79	As	b,g	25	112	Cd		202	143	Cs	b	366
80	As	b,g	29	113m	Cd	b,g	206	144	Cs	b	373
81	As	b	34	113	Cd	b	207	64	Cu	b,g	473
85	As	b	51	114	Cd		211	160	Dy		433
198	Au	b,g	479	115m	Cd	b,g	217	161	Dy		436
133	Ba	b,g	320	115	Cd	b,g	218	162	Dy		439
135m	Ba	g	327	116	Cd		224	165m	Dy	b,g	443
135	Ba		328	117m	Cd	b,g	229	165	Dy	b,g	444
136	Ba		332	117	Cd	b,g	230	166	Dy	b,g	446
137m	Ba	g	336	118	Cd	b	235	167m	Er	g	449
137	Ba		337	119m	Cd	b	238	150	Eu	g	400
138	Ba		341	119	Cd	b,g	239	151	Eu		404
139	Ba	b,g	345	121	Cd	b	246	152m	Eu	b,g	407
140	Ba	b,g	349	140	Ce		351	152	Eu	b,g	408
141	Ba	b,g	354	141	Ce	b,g	356	153	Eu		412
142	Ba	b,g	360	142	Ce		362	154	Eu	b,g	415
143	Ba	b	367	143	Ce	b,g	369	155	Eu	b,g	418

ISOSHLD Nuclide Library--Sorted Alphabetically

A	Name	rad	Weight	A	Name	rad	Weight	A	Name	rad	Weight
156	Eu	b,g	421	138	I	b	338	141	La	b,g	355
157	Eu	b,g	423	139	I	b	342	142	La	b,g	361
158	Eu	b,g	425	113	In		208	143	La	b,g	368
159	Eu	b,g	427	114m	In	g	212	144	La	b	375
160	Eu	b	430	114	In	b,g	213	27	Mg	b,g	455
55	Fe		467	115m	In	b,g	219	54	Mn	g	465
59	Fe	b,g	471	115	In	b	220	56	Mn	b,g	469
221	Fr	g	513	116m	In	b,g	225	94	Mo		112
72	Ga	b,g	2	116	In	b,g	226	95	Mo		120
73	Ga	b,g	5	117m	In	b,g	231	96	Mo		124
74	Ga	b,g	7	117	In	b,g	232	97	Mo		132
75	Ga	b,g	9	118	In	b,g	236	98	Mo		136
76	Ga	b,g	13	119m	In	b,g	240	99	Mo	b,g	139
152	Gd		409	119	In	b,g	241	100	Mo		144
154	Gd		416	120	In	b,g	244	101	Mo	b,g	148
155	Gd		419	121m	In	b	247	102	Mo	b	151
156	Gd		422	121	In	b,g	248	104	Mo	b	158
157	Gd		424	122	In	b,g	252	105	Mo	b	164
158	Gd		426	123	In	b,g	257	16	N	b,g	452
159	Gd	b,g	428	270	Jc	b	12	22	Na	b,g	529
160	Gd		431	271	Jc	b,g	14	24	Na	b,g	453
161	Gd	b,g	434	272	Jc	b,g	16	25	Na	b,g	454
162	Gd	b,g	437	273	Jc	b,g	21	93m	Nb	g	103
74	Ge		8	40	K	b,g	521	93	Nb		104
75m	Ge	g	10	80	Kr		33	94m	Nb	b,g	110
75	Ge	b,g	11	81	Kr		38	94	Nb	b,g	111
77m	Ge	b,g	17	82	Kr		41	95m	Nb	b,g	118
77	Ge	b,g	18	83m	Kr	g	45	95	Nb	b,g	119
78	Ge	b,g	22	83	Kr		46	96	Nb	b,g	123
203	Hg	b,g	480	84	Kr		50	97m	Nb	g	130
205	Hg	b,g	481	85m	Kr	b,g	54	97	Nb	b,g	131
165	Ho		445	85	Kr	b,g	55	98m	Nb	b	134
166	Ho	b,g	447	86	Kr		59	98	Nb	b,g	135
166m	Ho	b,g	448	87	Kr	b,g	65	99	Nb	b,g	138
127	I		280	88	Kr	b,g	70	100	Nb	b,g	143
128	I	b,g	285	89	Kr	b,g	74	101	Nb	b	147
129	I	b,g	290	90	Kr	b,g	80	142	Nd		364
130	I	b,g	295	91	Kr	b	86	143	Nd		371
131	I	b,g	300	92	Kr	b	93	144	Nd		378
132	I	b,g	305	93	Kr	b	98	145	Nd		381
133	I	b,g	310	94	Kr	b	105	146	Nd		384
134	I	b,g	316	95	Kr	b	113	147	Nd	b,g	387
135	I	b,g	323	97	Kr	b	125	148	Nd		392
136	I	b,g	329	139	La		346	149	Nd	b,g	396
137	I	b	333	140	La	b,g	350	150	Nd		399

ISOSHL D Nuclide Library--Sorted Alphabetically

A	Name	rad	Weight	A	Name	rad	Weight	A	Name	rad	Weight
151	Nd	b,g	401	239	Pu	g	493	108	Ru	b,g	179
237	Np	b,g	502	240	Pu	g	494	35	S	b	460
239	Np	g	503	241	Pu	b,g	495	121	Sb		251
32	P	b	459	242	Pu	g	497	122m	Sb	g	254
233	Pa	b,g	490	224	Ra	b,g	522	122	Sb	b,g	255
234	Pa	b,g	441	225	Ra	b,g	515	123	Sb		260
234m	Pa	b,g	533	226	Ra	b,g	485	124m	Sb	b,g	264
209	Pb	b	482	227	Ra	b,g	486	124	Sb	b,g	265
210	Pb	b,g	508	228	Ra	b,g	488	125	Sb	b,g	269
212	Pb	b,g	524	85	Rb		56	126m	Sb	b,g	273
214	Pb	b,g	510	86m	Rb	g	60	126	Sb	b,g	274
104	Pd		163	86	Rb	b,g	61	127	Sb	b,g	277
105	Pd		169	87	Rb	b	66	128m	Sb	b,g	282
106	Pd		173	88	Rb	b,g	71	128	Sb	b,g	283
107	Pd	b	177	89	Rb	b,g	75	129	Sb	b,g	287
108	Pd		181	90	Rb	b,g	81	130	Sb	b,g	293
109m	Pd	g	186	91m	Rb	b	87	131	Sb	b,g	297
109	Pd	b,g	187	91	Rb	b	88	132	Sb	b	303
110	Pd		190	92	Rb	b	94	133	Sb	b	307
111m	Pd	b,g	194	93	Rb	b	99	134	Sb	b	314
111	Pd	b,g	195	94	Rb	b	106	135	Sb	b	321
112	Pd	b,g	200	95	Rb	b	114	46	Sc	b,g	462
113	Pd	b	203	97	Rb	b	126	47	Sc	b,g	463
114	Pd	b	209	103m	Rh	g	156	77m	Se	g	20
115	Pd	b	214	103	Rh		157	78	Se		24
116	Pd	b	222	104m	Rh	b,g	161	79m	Se	g	26
146	Pm	b,g	477	104	Rh	b,g	162	79	Se	b	27
147	Pm	b,g	388	105m	Rh	g	167	80	Se		30
148m	Pm	b,g	393	105	Rh	b,g	168	81m	Se	g	35
148	Pm	b,g	394	106m	Rh	b,g	171	81	Se	b,g	36
149	Pm	b,g	397	106	Rh	b,g	172	82	Se		39
151	Pm	b,g	402	107	Rh	b,g	176	83m	Se	b,g	42
152	Pm	b,g	405	108	Rh	b,g	180	83	Se	b,g	43
153	Pm	b,g	410	109	Rh	b	185	84	Se	b,g	47
154	Pm	b	413	220	Rn	g	523	85	Se	b	52
214	Po	g	512	222	Rn	g	514	86	Se	b	57
141	Pr		357	99	Ru		142	87	Se	b	63
142	Pr	b,g	363	100	Ru		146	31	Si	b,g	458
143	Pr	b	370	101	Ru		150	147	Sm		389
144	Pr	b,g	377	102	Ru		153	148	Sm		395
145	Pr	b,g	380	103	Ru	b,g	155	149	Sm		398
146	Pr	b,g	383	104	Ru		160	151	Sm	b,g	403
147	Pr	b,g	386	105	Ru	b,g	166	152	Sm		406
148	Pr	b,g	391	106	Ru	b	170	153	Sm	b,g	411
238	Pu	g	492	107	Ru	b,g	175	154	Sm		414

ISOSHLN Nuclide Library--Sorted Alphabetically

A	Name	rad	Weight	A	Name	rad	Weight	A	Name	rad	Weight
155	Sm	b,g	417	100	Tc	b,g	145	131	Xe		302
156	Sm	b,g	420	101	Tc	b,g	149	132	Xe		306
115	Sn		221	102	Tc	b,g	152	133m	Xe	g	311
116	Sn		227	103	Tc	b,g	154	133	Xe	b,g	312
117m	Sn	g	233	104	Tc	b,g	159	134	Xe		317
117	Sn		234	105	Tc	b,g	165	135m	Xe	g	324
118	Sn		237	107	Tc	b	174	135	Xe	b,g	325
119m	Sn	g	242	122	Te		256	136	Xe		330
119	Sn		243	123m	Te	g	261	137	Xe	b,g	334
120	Sn		245	123	Te		262	138	Xe	b,g	339
121m	Sn	b,g	249	124	Te		266	139	Xe	b,g	343
121	Sn	b	250	125m	Te	b,g	270	140	Xe	b,g	347
122	Sn		253	125	Te		271	141	Xe	b	352
123m	Sn	b,g	258	126	Te		275	142	Xe	b,g	358
123	Sn	b,g	259	127m	Te	b,g	278	143	Xe	b	365
124	Sn		263	127	Te	b,g	279	144	Xe	b	372
125m	Sn	b,g	267	128	Te		284	89m	Y	g	77
125	Sn	b,g	268	129m	Te	b,g	288	89	Y		78
126	Sn	b,g	272	129	Te	b,g	289	90m	Y	b,g	83
127	Sn	b,g	276	130	Te		294	90	Y	b,g	84
128	Sn	b,g	281	131m	Te	b,g	298	91m	Y	g	90
130	Sn	b	292	131	Te	b,g	299	91	Y	b,g	91
85m	Sr	g	532	132	Te	b,g	304	92	Y	b,g	96
86	Sr		62	133m	Te	b,g	308	93	Y	b,g	101
87m	Sr	g	67	133	Te	b,g	309	94	Y	b,g	108
87	Sr		68	134	Te	b,g	315	95	Y	b,g	116
88	Sr		72	135	Te	b	322	96	Y	b,g	121
89	Sr	b,g	76	228	Th	b,g	442	97	Y	b	128
90	Sr	b	82	229	Th	g	517	65	Zn	g	474
91	Sr	b,g	89	230	Th	g	518	69	Zn	b	475
92	Sr	b,g	95	231	Th	b,g	450	72	Zn	b,g	1
93	Sr	b,g	100	233	Th	b,g	489	73	Zn		4
94	Sr	b,g	107	234	Th	b,g	530	90	Zr		85
95	Sr	b	115	210	Tl	b,g	484	91	Zr		92
97	Sr	b	127	233	U	g	519	92	Zr		97
182	Ta	b,g	501	234	U	b,g	520	93	Zr	b	102
159	Tb		429	235	U	b,g	476	94	Zr		109
160	Tb	b,g	432	237	U	b,g	491	95	Zr	b,g	117
161	Tb	b,g	435	238	U	b,g	526	96	Zr		122
162	Tb	b,g	438	187	W	b,g	478	97	Zr	b,g	129
163	Tb	b,g	440	128	Xe		286	98	Zr	b	133
95	Tc	b,g	531	129	Xe		291	99	Zr	b	137
99m	Tc	g	140	130	Xe		296				
99	Tc	b	141	131m	Xe	g	301				

This page intentionally left blank.

APPENDIX E

OUTPUT GENERATED BY THE SAMPLE INPUT FILE

This page intentionally left blank.

Contents of Full Output File: CSSR.19

Run started at 09:00:00 08/06/94

ISO-PC Version 1.98 August 1994
originally ISOSHLD-II; RIBD was removed

Please send questions or comments to:
Paul D. Rittmann, PhD CHP 509-376-8715
Westinghouse Hanford Company H6-30
PO Box 1970 Richland, WA 99352

Title Line from Library File (ISO-PC.LIB):

Attenuation & Buildup for 30 Groups; Photon & Beta Production 7/6/94 PDR

Run Title: Standard 55 gallon Drum with Cs & Sr Contaminated Waste

Low Density Source, 3 ft Away

Table of Source Activity:

Scale Factor = 1.000E+00

Isotope Name	Initial Values	Final Curies
SR- 90	7.00E+00	7.000E+00
Y - 90	7.00E+00	7.000E+00
CS-137	1.00E+00	1.000E+00
BA-137M	9.46E-01	9.460E-01

Low Density Source, 3 ft Away

Shield Composition, g/cc

	Shield 1	Shield 2	Shield 3
TISSUE	1.000E-02	0.000E+00	0.000E+00
AIR	0.000E+00	0.000E+00	1.290E-03
IRON	0.000E+00	7.860E+00	0.000E+00

Totals: 1.000E-02 7.860E+00 1.290E-03

E, Mev	Linear Attenuation, per cm (last region is air)		
0.015	8.913E-03	4.622E+02	2.046E-03
0.025	4.168E-03	1.096E+02	6.138E-04
0.035	3.296E-03	4.186E+01	3.664E-04
0.045	2.967E-03	2.035E+01	2.837E-04
0.055	2.800E-03	1.178E+01	2.491E-04
0.065	2.688E-03	7.715E+00	2.314E-04
0.075	2.593E-03	5.451E+00	2.184E-04
0.085	2.515E-03	4.096E+00	2.090E-04
0.095	2.450E-03	3.237E+00	2.019E-04
0.150	2.165E-03	1.541E+00	1.758E-04
0.250	1.835E-03	9.660E-01	1.477E-04
0.350	1.619E-03	7.923E-01	1.298E-04
0.475	1.435E-03	6.768E-01	1.146E-04
0.650	1.254E-03	5.813E-01	1.001E-04
0.825	1.122E-03	5.172E-01	8.984E-05
1.000	1.024E-03	4.700E-01	8.194E-05
1.225	9.283E-04	4.239E-01	7.398E-05
1.475	8.438E-04	3.860E-01	6.718E-05
1.700	7.812E-04	3.602E-01	6.249E-05
1.900	7.339E-04	3.420E-01	5.889E-05
2.100	6.938E-04	3.268E-01	5.564E-05
2.300	6.581E-04	3.141E-01	5.263E-05
2.500	6.266E-04	3.033E-01	5.003E-05
2.700	5.998E-04	2.942E-01	4.778E-05
3.000	5.641E-04	2.830E-01	4.511E-05
3.600	5.079E-04	2.669E-01	4.158E-05
4.500	4.451E-04	2.521E-01	3.746E-05
5.500	3.942E-04	2.428E-01	3.381E-05
6.600	3.545E-04	2.371E-01	3.111E-05
8.600	3.037E-04	2.325E-01	2.771E-05

Low Density Source, 3 ft Away

Photon Production Rate for Each Radionuclide:

ISOSHLD Energy Group Structure:

Group Number	Photon Energy, Mev			Group Number	Photon Energy, Mev		
	Low	Mid	High		Low	Mid	High
1	0.010	0.015	0.020	16	0.900	1.000	1.100
2	0.020	0.025	0.030	17	1.100	1.225	1.350
3	0.030	0.035	0.040	18	1.350	1.475	1.600
4	0.040	0.045	0.050	19	1.600	1.700	1.800
5	0.050	0.055	0.060	20	1.800	1.900	2.000
6	0.060	0.065	0.070	21	2.000	2.100	2.200
7	0.070	0.075	0.080	22	2.200	2.300	2.400
8	0.080	0.085	0.090	23	2.400	2.500	2.600

WHC-SD-WM-UM-030
Revision 0

9	0.090	0.095	0.100	24	2.600	2.700	2.800
10	0.100	0.150	0.200	25	2.800	3.000	3.200
11	0.200	0.250	0.300	26	3.200	3.600	4.000
12	0.300	0.350	0.400	27	4.000	4.500	5.000
13	0.400	0.475	0.550	28	5.000	5.500	6.000
14	0.550	0.650	0.750	29	6.000	6.600	7.200
15	0.750	0.825	0.900	30	7.200	8.600	10.000

Nuclide 82 is SR- 90 (Z = 38)

Group No.	Gamma X-ray	Brems	Total photon/sec
1	0.000E+00	7.521E+08	7.521E+08
2	0.000E+00	4.679E+08	4.679E+08
3	0.000E+00	2.648E+08	2.648E+08
4	0.000E+00	1.343E+08	1.343E+08
5	0.000E+00	1.007E+08	1.007E+08
6	0.000E+00	7.049E+07	7.049E+07
7	0.000E+00	5.265E+07	5.265E+07
8	0.000E+00	4.193E+07	4.193E+07
9	0.000E+00	3.164E+07	3.164E+07
10	0.000E+00	1.228E+08	1.228E+08
11	0.000E+00	2.047E+07	2.047E+07
12	0.000E+00	3.209E+06	3.209E+06
13	0.000E+00	3.569E+05	3.569E+05

Weight(82) = 7.000E+00 Ci

Group No.	Gamma X-ray	Brems	Total photon/sec
16	0.000E+00	0.000E+00	0.000E+00
17	0.000E+00	0.000E+00	0.000E+00
18	0.000E+00	0.000E+00	0.000E+00
19	0.000E+00	0.000E+00	0.000E+00
20	0.000E+00	0.000E+00	0.000E+00
21	0.000E+00	0.000E+00	0.000E+00
22	0.000E+00	0.000E+00	0.000E+00
23	0.000E+00	0.000E+00	0.000E+00
24	0.000E+00	0.000E+00	0.000E+00
25	0.000E+00	0.000E+00	0.000E+00
26	0.000E+00	0.000E+00	0.000E+00
27	0.000E+00	0.000E+00	0.000E+00
28	0.000E+00	0.000E+00	0.000E+00

Totals: 0.000E+00 2.063E+09 2.063E+09

Nuclide 84 is Y - 90 (Z = 39)

Group No.	Gamma X-ray	Brems	Total photon/sec
1	1.968E+07	4.843E+09	4.862E+09
2	0.000E+00	2.468E+09	2.468E+09
3	0.000E+00	1.545E+09	1.545E+09
4	0.000E+00	1.121E+09	1.121E+09
5	0.000E+00	8.139E+08	8.139E+08
6	0.000E+00	7.115E+08	7.115E+08
7	0.000E+00	6.584E+08	6.584E+08
8	0.000E+00	6.054E+08	6.054E+08
9	0.000E+00	5.523E+08	5.523E+08
10	0.000E+00	2.828E+09	2.828E+09
11	0.000E+00	9.171E+08	9.171E+08
12	0.000E+00	4.601E+08	4.601E+08
13	0.000E+00	3.600E+08	3.600E+08
14	0.000E+00	2.244E+08	2.244E+08
15	0.000E+00	8.362E+07	8.362E+07

Weight(84) = 7.000E+00 Ci

Group No.	Gamma X-ray	Brems	Total photon/sec
16	0.000E+00	5.855E+07	5.855E+07
17	0.000E+00	3.122E+07	3.122E+07
18	0.000E+00	1.073E+07	1.073E+07
19	8.806E+06	2.537E+06	1.134E+07
20	0.000E+00	5.785E+05	5.785E+05
21	3.626E+05	4.999E+04	4.126E+05
22	0.000E+00	7.431E+02	7.431E+02
23	0.000E+00	0.000E+00	0.000E+00
24	0.000E+00	0.000E+00	0.000E+00
25	0.000E+00	0.000E+00	0.000E+00
26	0.000E+00	0.000E+00	0.000E+00
27	0.000E+00	0.000E+00	0.000E+00
28	0.000E+00	0.000E+00	0.000E+00
29	0.000E+00	0.000E+00	0.000E+00
30	0.000E+00	0.000E+00	0.000E+00

Totals: 2.885E+07 1.830E+10 1.832E+10

WHC-SD-WM-UM-030
Revision 0

Nuclide 335 is CS-137 (Z = 55)				Weight(335) = 1.000E+00 Ci			
Group No.	Gamma X-ray	Brems	Total photon/sec	Group No.	Gamma X-ray	Brems	Total photon/sec
1	0.000E+00	1.114E+08	1.114E+08	16	0.000E+00	3.984E+03	3.984E+03
2	0.000E+00	6.528E+07	6.528E+07	17	0.000E+00	3.141E+01	3.141E+01
3	0.000E+00	3.499E+07	3.499E+07	18	0.000E+00	0.000E+00	0.000E+00
4	0.000E+00	2.094E+07	2.094E+07	19	0.000E+00	0.000E+00	0.000E+00
5	0.000E+00	1.584E+07	1.584E+07	20	0.000E+00	0.000E+00	0.000E+00
6	0.000E+00	1.114E+07	1.114E+07	21	0.000E+00	0.000E+00	0.000E+00
7	0.000E+00	8.588E+06	8.588E+06	22	0.000E+00	0.000E+00	0.000E+00
8	0.000E+00	6.259E+06	6.259E+06	23	0.000E+00	0.000E+00	0.000E+00
9	0.000E+00	4.800E+06	4.800E+06	24	0.000E+00	0.000E+00	0.000E+00
10	0.000E+00	1.960E+07	1.960E+07	25	0.000E+00	0.000E+00	0.000E+00
11	0.000E+00	3.944E+06	3.944E+06	26	0.000E+00	0.000E+00	0.000E+00
12	0.000E+00	1.076E+06	1.076E+06	27	0.000E+00	0.000E+00	0.000E+00
13	0.000E+00	4.998E+05	4.998E+05	28	0.000E+00	0.000E+00	0.000E+00
14	0.000E+00	1.724E+05	1.724E+05	29	0.000E+00	0.000E+00	0.000E+00
15	0.000E+00	2.557E+04	2.557E+04	30	0.000E+00	0.000E+00	0.000E+00
			Totals:	0.000E+00	3.046E+08	3.046E+08	

Nuclide 336 is BA-137M (Z = 56)				Weight(336) = 9.460E-01 Ci			
Group No.	Gamma X-ray	Brems	Total photon/sec	Group No.	Gamma X-ray	Brems	Total photon/sec
3	2.548E+09	0.000E+00	2.548E+09	18	0.000E+00	0.000E+00	0.000E+00
14	3.149E+10	0.000E+00	3.149E+10	29	0.000E+00	0.000E+00	0.000E+00
			Totals:	3.404E+10	0.000E+00	3.404E+10	

Low Density Source, 3 ft Away

Source Cylindrical Shields Slab Distance to Detector, X = 1.196E+02 cm
Source Volume = 2.020E+05 cc
Source Mass = 2.020E+03 grams
Source Length = 8.200E+01 cm Distance Along Cylinder, Y = 4.100E+01 cm
Integration Specs: NTHETA = 9 NPSI = 11 DELR = 2.000E+00 cm
Total Intervals: 1.386E+03 (photon source is the 1st region)
Shield Thickness: 2.800E+01, 1.600E-01, 9.144E+01 cm
Distances from Dose Point to the Outside of
(1) Source Region: 9.160E+01 cm (2) Next Layer: 9.144E+01 cm
Dose Buildup Data for Shield 1 with Effective Atomic Number 3.44
Fluence-to-Dose Conversion: Photons in Air

Average E, Mev	Source Total photons/sec	Fluence to Dose Factor	Energy Fluence Mev/sq.cm/sec	Dose Rate R/hr
0.015	5.726E+09	8.183E-05	3.466E-28	2.836E-32
0.025	3.001E+09	1.656E-05	3.556E-04	5.888E-09
0.035	4.393E+09	6.084E-06	3.762E+00	2.289E-05
0.045	1.276E+09	3.203E-06	2.464E+01	7.893E-05

WHC-SD-WM-UM-030

Revision 0

0.055	9.305E+08	2.216E-06	6.985E+01	1.548E-04
0.065	7.931E+08	1.827E-06	1.110E+02	2.028E-04
0.075	7.197E+08	1.664E-06	1.341E+02	2.231E-04
0.085	6.535E+08	1.603E-06	1.666E+02	2.671E-04
0.095	5.887E+08	1.592E-06	1.904E+02	3.030E-04
0.150	2.971E+09	1.728E-06	1.927E+03	3.330E-03
0.250	9.416E+08	1.935E-06	1.143E+03	2.213E-03
0.350	4.644E+08	2.019E-06	8.099E+02	1.635E-03
0.475	3.608E+08	2.043E-06	8.491E+02	1.735E-03
0.650	3.172E+10	2.029E-06	9.667E+04	1.961E-01
0.825	8.365E+07	1.983E-06	3.038E+02	6.024E-04
1.000	5.855E+07	1.923E-06	2.468E+02	4.747E-04
1.225	3.122E+07	1.850E-06	1.584E+02	2.931E-04
1.475	1.073E+07	1.775E-06	6.519E+01	1.157E-04
1.700	1.134E+07	1.712E-06	7.856E+01	1.345E-04
1.900	5.785E+05	1.660E-06	4.433E+00	7.358E-06
2.100	4.126E+05	1.613E-06	3.472E+00	5.600E-06
2.300	7.431E+02	1.592E-06	6.823E-03	1.086E-08

Totals: 5.474E+10 photons/sec 1.030E+05 2.079E-01 R/hr
= 1.490E-08 amp/kg

Low Density Source, Contact (2 inches)

Source Cylindrical Shields Slab Distance to Detector, X = 3.324E+01 cm
Source Volume = 2.020E+05 cc
Source Mass = 2.020E+03 grams
Source Length = 8.200E+01 cm Distance Along Cylinder, Y = 4.100E+01 cm
Integration Specs: NTHETA = 9 NPSI = 11 DELR = 2.000E+00 cm
Total Intervals: 1.386E+03 (photon source is the 1st region)
Shield Thickness: 2.800E+01, 1.600E-01, 5.080E+00 cm
Distances from Dose Point to the Outside of
(1) Source Region: 5.240E+00 cm (2) Next Layer: 5.080E+00 cm
Dose Buildup Data for Shield 1 with Effective Atomic Number 3.44
Fluence-to-Dose Conversion: Photons in Air

Average E, Mev	Source Total photons/sec	Fluence to Dose Factor	Energy Fluence Mev/sq.cm/sec	Dose Rate R/hr
0.015	5.726E+09	8.183E-05	1.584E-27	1.296E-31
0.025	3.001E+09	1.656E-05	4.911E-03	8.132E-08
0.035	4.393E+09	6.084E-06	1.280E+02	7.785E-04
0.045	1.276E+09	3.203E-06	8.346E+02	2.673E-03
0.055	9.305E+08	2.216E-06	2.081E+03	4.612E-03
0.065	7.931E+08	1.827E-06	2.961E+03	5.410E-03
0.075	7.197E+08	1.664E-06	3.549E+03	5.906E-03
0.085	6.535E+08	1.603E-06	4.040E+03	6.477E-03
0.095	5.887E+08	1.592E-06	4.409E+03	7.019E-03
0.150	2.971E+09	1.728E-06	3.838E+04	6.633E-02
0.250	9.416E+08	1.935E-06	1.979E+04	3.829E-02
0.350	4.644E+08	2.019E-06	1.333E+04	2.692E-02

WHC-SD-WM-UM-030
Revision 0

0.475	3.608E+08	2.043E-06	1.355E+04	2.767E-02
0.650	3.172E+10	2.029E-06	1.518E+06	3.079E+00
0.825	8.365E+07	1.983E-06	4.761E+03	9.440E-03
1.000	5.855E+07	1.923E-06	3.869E+03	7.440E-03
1.225	3.122E+07	1.850E-06	2.466E+03	4.561E-03
1.475	1.073E+07	1.775E-06	1.006E+03	1.785E-03
1.700	1.134E+07	1.712E-06	1.208E+03	2.069E-03
1.900	5.785E+05	1.660E-06	6.814E+01	1.131E-04
2.100	4.126E+05	1.613E-06	5.331E+01	8.598E-05
2.300	7.431E+02	1.592E-06	1.046E-01	1.665E-07

Totals:	5.474E+10 photons/sec		1.634E+06	3.297E+00 R/hr = 2.363E-07 amp/kg

Soil Filled Drum, Contact (2 in)

Table of Source Activity:

Scale Factor = 1.000E-01

Isotope Name	Initial Values	Final Curies
SR- 90	7.00E+00	7.000E-01
Y - 90	7.00E+00	7.000E-01
CS-137	1.00E+00	1.000E-01
BA-137M	9.46E-01	9.460E-02

Soil Filled Drum, Contact (2 in)

Shield Composition, g/cc

	Shield 1	Shield 2	Shield 3
AIR	0.000E+00	0.000E+00	1.290E-03
ORD CONC	1.500E+00	0.000E+00	0.000E+00
IRON	0.000E+00	7.860E+00	0.000E+00
Totals:	1.500E+00	7.860E+00	1.290E-03

E, Mev Linear Attenuation, per cm (last region is air)

0.015	1.272E+01	4.622E+02	2.046E-03
0.025	2.976E+00	1.096E+02	6.138E-04
0.035	1.238E+00	4.186E+01	3.664E-04
0.045	7.062E-01	2.035E+01	2.837E-04
0.055	4.959E-01	1.178E+01	2.491E-04
0.065	3.943E-01	7.715E+00	2.314E-04

0.075	3.357E-01	5.451E+00	2.184E-04
0.085	2.995E-01	4.096E+00	2.090E-04
0.095	2.757E-01	3.237E+00	2.019E-04
0.150	2.157E-01	1.541E+00	1.758E-04
0.250	1.746E-01	9.660E-01	1.477E-04
0.350	1.524E-01	7.923E-01	1.298E-04
0.475	1.343E-01	6.768E-01	1.146E-04
0.650	1.170E-01	5.813E-01	1.001E-04
0.825	1.049E-01	5.172E-01	8.984E-05
1.000	9.561E-02	4.700E-01	8.194E-05
1.225	8.637E-02	4.239E-01	7.398E-05
1.475	7.849E-02	3.860E-01	6.718E-05
1.700	7.294E-02	3.602E-01	6.249E-05
1.900	6.888E-02	3.420E-01	5.889E-05
2.100	6.546E-02	3.268E-01	5.564E-05
2.300	6.246E-02	3.141E-01	5.263E-05
2.500	5.990E-02	3.033E-01	5.003E-05
2.700	5.760E-02	2.942E-01	4.778E-05
3.000	5.474E-02	2.830E-01	4.511E-05
3.600	5.020E-02	2.669E-01	4.158E-05
4.500	4.535E-02	2.521E-01	3.746E-05
5.500	4.170E-02	2.428E-01	3.381E-05
6.600	3.897E-02	2.371E-01	3.111E-05
8.600	3.581E-02	2.325E-01	2.771E-05

Soil Filled Drum, Contact (2 in)

Photon Production Rate for Each Radionuclide:

Nuclide Group No.	82 is SR- 90 (Z = 38)			Weight(82) = 7.000E-01 Ci			
	Gamma X-ray	Brems	Total photon/sec	Group No.	Gamma X-ray	Brems	Total photon/sec
1	0.000E+00	1.211E+08	1.211E+08	16	0.000E+00	0.000E+00	0.000E+00
2	0.000E+00	7.470E+07	7.470E+07	17	0.000E+00	0.000E+00	0.000E+00
3	0.000E+00	4.198E+07	4.198E+07	18	0.000E+00	0.000E+00	0.000E+00
4	0.000E+00	2.097E+07	2.097E+07	19	0.000E+00	0.000E+00	0.000E+00
5	0.000E+00	1.566E+07	1.566E+07	20	0.000E+00	0.000E+00	0.000E+00
6	0.000E+00	1.089E+07	1.089E+07	21	0.000E+00	0.000E+00	0.000E+00
7	0.000E+00	8.082E+06	8.082E+06	22	0.000E+00	0.000E+00	0.000E+00
8	0.000E+00	6.407E+06	6.407E+06	23	0.000E+00	0.000E+00	0.000E+00
9	0.000E+00	4.800E+06	4.800E+06	24	0.000E+00	0.000E+00	0.000E+00
10	0.000E+00	1.826E+07	1.826E+07	25	0.000E+00	0.000E+00	0.000E+00
11	0.000E+00	2.868E+06	2.868E+06	26	0.000E+00	0.000E+00	0.000E+00
12	0.000E+00	4.184E+05	4.184E+05	27	0.000E+00	0.000E+00	0.000E+00
13	0.000E+00	4.349E+04	4.349E+04	28	0.000E+00	0.000E+00	0.000E+00

Totals: 0.000E+00 3.262E+08 3.262E+08

WHC-SD-WM-UM-030
Revision 0

Nuclide 84 is Y - 90 (Z = 39)				Weight(84) = 7.000E-01 Ci			
Group No.	Gamma X-ray	Brems	Total photon/sec	Group No.	Gamma X-ray	Brems	Total photon/sec
1	1.968E+06	8.037E+08	8.056E+08	16	0.000E+00	7.785E+06	7.785E+06
2	0.000E+00	4.073E+08	4.073E+08	17	0.000E+00	3.975E+06	3.975E+06
3	0.000E+00	2.540E+08	2.540E+08	18	0.000E+00	1.301E+06	1.301E+06
4	0.000E+00	1.825E+08	1.825E+08	19	8.806E+05	2.936E+05	1.174E+06
5	0.000E+00	1.314E+08	1.314E+08	20	0.000E+00	6.437E+04	6.437E+04
6	0.000E+00	1.146E+08	1.146E+08	21	3.626E+04	5.352E+03	4.161E+04
7	0.000E+00	1.060E+08	1.060E+08	22	0.000E+00	7.821E+01	7.821E+01
8	0.000E+00	9.740E+07	9.740E+07	23	0.000E+00	0.000E+00	0.000E+00
9	0.000E+00	8.877E+07	8.877E+07	24	0.000E+00	0.000E+00	0.000E+00
10	0.000E+00	4.499E+08	4.499E+08	25	0.000E+00	0.000E+00	0.000E+00
11	0.000E+00	1.415E+08	1.415E+08	26	0.000E+00	0.000E+00	0.000E+00
12	0.000E+00	6.936E+07	6.936E+07	27	0.000E+00	0.000E+00	0.000E+00
13	0.000E+00	5.296E+07	5.296E+07	28	0.000E+00	0.000E+00	0.000E+00
14	0.000E+00	3.194E+07	3.194E+07	29	0.000E+00	0.000E+00	0.000E+00
15	0.000E+00	1.149E+07	1.149E+07	30	0.000E+00	0.000E+00	0.000E+00

Totals: 2.885E+06 2.956E+09 2.959E+09

Nuclide 335 is CS-137 (Z = 55)				Weight(335) = 1.000E-01 Ci			
Group No.	Gamma X-ray	Brems	Total photon/sec	Group No.	Gamma X-ray	Brems	Total photon/sec
1	0.000E+00	1.799E+07	1.799E+07	16	0.000E+00	4.497E+02	4.497E+02
2	0.000E+00	1.044E+07	1.044E+07	17	0.000E+00	3.336E+00	3.336E+00
3	0.000E+00	5.544E+06	5.544E+06	18	0.000E+00	0.000E+00	0.000E+00
4	0.000E+00	3.288E+06	3.288E+06	19	0.000E+00	0.000E+00	0.000E+00
5	0.000E+00	2.478E+06	2.478E+06	20	0.000E+00	0.000E+00	0.000E+00
6	0.000E+00	1.732E+06	1.732E+06	21	0.000E+00	0.000E+00	0.000E+00
7	0.000E+00	1.329E+06	1.329E+06	22	0.000E+00	0.000E+00	0.000E+00
8	0.000E+00	9.609E+05	9.609E+05	23	0.000E+00	0.000E+00	0.000E+00
9	0.000E+00	7.317E+05	7.317E+05	24	0.000E+00	0.000E+00	0.000E+00
10	0.000E+00	2.935E+06	2.935E+06	25	0.000E+00	0.000E+00	0.000E+00
11	0.000E+00	5.650E+05	5.650E+05	26	0.000E+00	0.000E+00	0.000E+00
12	0.000E+00	1.496E+05	1.496E+05	27	0.000E+00	0.000E+00	0.000E+00
13	0.000E+00	6.768E+04	6.768E+04	28	0.000E+00	0.000E+00	0.000E+00
14	0.000E+00	2.204E+04	2.204E+04	29	0.000E+00	0.000E+00	0.000E+00
15	0.000E+00	3.045E+03	3.045E+03	30	0.000E+00	0.000E+00	0.000E+00

Totals: 0.000E+00 4.824E+07 4.824E+07

Nuclide 336 is BA-137M (Z = 56)				Weight(336) = 9.460E-02 Ci			
Group No.	Gamma X-ray	Brems	Total photon/sec	Group No.	Gamma X-ray	Brems	Total photon/sec
3	2.548E+08	0.000E+00	2.548E+08	18	0.000E+00	0.000E+00	0.000E+00
14	3.149E+09	0.000E+00	3.149E+09	29	0.000E+00	0.000E+00	0.000E+00

Totals: 3.404E+09 0.000E+00 3.404E+09

WHC-SD-WM-UM-030
Revision 0

Shield Thickness: 2.800E+01, 1.600E-01, 9.144E+01 cm
Distances from Dose Point to the Outside of
(1) Source Region: 9.160E+01 cm (2) Next Layer: 9.144E+01 cm
Dose Buildup Data for Shield 1 with Effective Atomic Number 9.39
Source Scale Factor was 1.000E-01
Fluence-to-Dose Conversion: Photons in Air

Average E, Mev	Source Total photons/sec	Fluence to Dose Factor	Energy Fluence Mev/sq.cm/sec	Dose Rate R/hr
0.015	9.447E+08	8.183E-05	3.279E-31	2.683E-35
0.025	4.925E+08	1.656E-05	3.280E-07	5.432E-12
0.035	5.563E+08	6.084E-06	5.540E-03	3.370E-08
0.045	2.067E+08	3.203E-06	9.088E-02	2.911E-07
0.055	1.495E+08	2.216E-06	4.502E-01	9.976E-07
0.065	1.273E+08	1.827E-06	1.143E+00	2.088E-06
0.075	1.154E+08	1.664E-06	2.147E+00	3.572E-06
0.085	1.048E+08	1.603E-06	3.302E+00	5.293E-06
0.095	9.430E+07	1.592E-06	4.558E+00	7.257E-06
0.150	4.711E+08	1.728E-06	5.279E+01	9.122E-05
0.250	1.449E+08	1.935E-06	4.184E+01	8.096E-05
0.350	6.993E+07	2.019E-06	3.264E+01	6.591E-05
0.475	5.307E+07	2.043E-06	3.566E+01	7.286E-05
0.650	3.181E+09	2.029E-06	3.064E+03	6.217E-03
0.825	1.149E+07	1.983E-06	1.466E+01	2.907E-05
1.000	7.785E+06	1.923E-06	1.252E+01	2.407E-05
1.225	3.975E+06	1.850E-06	8.174E+00	1.512E-05
1.475	1.301E+06	1.775E-06	3.366E+00	5.975E-06
1.700	1.174E+06	1.712E-06	3.625E+00	6.206E-06
1.900	6.437E+04	1.660E-06	2.279E-01	3.784E-07
2.100	4.161E+04	1.613E-06	1.664E-01	2.684E-07
2.300	7.821E+01	1.592E-06	3.490E-04	5.556E-10
Totals:	6.738E+09 photons/sec		3.281E+03	6.629E-03 R/hr = 4.750E-10 amp/kg

Closing: This is the End of the Drum Case !!

Finish run at 09:00:19 08/06/94
Input File (CSSR.) is shown below:

```

0      2 Standard 55 gallon Drum with Cs & Sr Contaminated Waste
Low Density Source, 3 ft Away
&Input Next=1,
  IGeom= 8, SLTH= 82, Y= 41, T(1)= 28, 0.16, X= 119.6,
  NShld= 2, JBuf= 1, NTheta= 9, NPsi= 11, Delr= 2.0, Option= 1,
  Weight(82)= 7, Weight(84)= 7, Weight(335)= 1, 0.946 &
  misc 2 0.01
1 iron 9 7.86
Low Density Source, Contact (2 inches)
&Input Next= 4, x= 33.24 &

```

```
Soil Filled Drum, Contact (2 in)
  &Input Next= 3, SFact= 0.1 &
  conc 16 1.5
1 iron 9 7.86
Soil Filled Drum, 3 ft Away
*****> this second line will be ignored
  &Input Next= 4, X= 119.6 &
This is the End of the Drum Case !!
&Input Next= 6 &
```

The factor 0.1 in the third case checks the use of SFact in the
Option=1 tables.

Contents of Summary Output File: CSSR.19S

Standard 55 gallon Drum with Cs & Sr Contaminated Waste

2.079E-01 R/hr	Low Density Source, 3 ft Away
3.297E+00 R/hr	Low Density Source, Contact (2 inches)
1.224E-01 R/hr	Soil Filled Drum, Contact (2 in)
6.629E-03 R/hr	Soil Filled Drum, 3 ft Away

This page intentionally left blank.