

348
10-20-78
25 exp to NPLS

59c

19. 629

DOE / NASA CONTRACTOR REPORT

DOE / NASA CR-150757

MASTER

INSTALLATION PACKAGE FOR A SOLAR HEATING AND HOT WATER SYSTEM

Prepared by

Colt, Inc.
71-590 San Jacinto Drive
Rancho Mirage, California 92270

Under Contract NAS8-32242 with

National Aeronautics and Space Administration
George C. Marshall Space Flight Center, Alabama 35812

For the U. S. Department of Energy



U.S. Department of Energy



Solar Energy

DISTRIBUTION OF THIS DOCUMENT IS UNLIMITED

DISCLAIMER

This report was prepared as an account of work sponsored by an agency of the United States Government. Neither the United States Government nor any agency Thereof, nor any of their employees, makes any warranty, express or implied, or assumes any legal liability or responsibility for the accuracy, completeness, or usefulness of any information, apparatus, product, or process disclosed, or represents that its use would not infringe privately owned rights. Reference herein to any specific commercial product, process, or service by trade name, trademark, manufacturer, or otherwise does not necessarily constitute or imply its endorsement, recommendation, or favoring by the United States Government or any agency thereof. The views and opinions of authors expressed herein do not necessarily state or reflect those of the United States Government or any agency thereof.

DISCLAIMER

Portions of this document may be illegible in electronic image products. Images are produced from the best available original document.

NOTICE

This report was prepared to document work sponsored by the United States Government. Neither the United States nor its agents the United States Department of Energy, the United States National Aeronautics and Space Administration, nor any federal employees, nor any of their contractors, subcontractors or their employees, make any warranty, express or implied, or assume any legal liability or responsibility for the accuracy, completeness, or usefulness of any information, apparatus, product or process disclosed, or represent that its use would not infringe privately owned rights.

1. REPORT NO. DOE NASA CR-150757		2. GOVERNMENT ACCESSION NO.		3. RECIPIENT'S CATALOG NO.	
4. TITLE AND SUBTITLE Installation Package for a Solar Heating and Hot Water System				5. REPORT DATE August 1978	
				6. PERFORMING ORGANIZATION CODE	
7. AUTHOR(S)				8. PERFORMING ORGANIZATION REPORT #	
9. PERFORMING ORGANIZATION NAME AND ADDRESS Colt, Inc. 71-590 San Jacinto Drive Rancho Mirage, CA 92270				10. WORK UNIT NO.	
				11. CONTRACT OR GRANT NO. NAS8-32242	
12. SPONSORING AGENCY NAME AND ADDRESS National Aeronautics and Space Administration Washington, D. C. 20546				13. TYPE OF REPORT & PERIOD COVERED Contractor Report	
				14. SPONSORING AGENCY CODE	
15. SUPPLEMENTARY NOTES This work was done under the technical management of Mr. Mitchell Cash, George C. Marshall Space Flight Center, Alabama.					
16. ABSTRACT Colt, Incorporated of Southern California, under NASA/MSFC Contract NAS8-32242, has developed two commercial solar heating and hot water systems. The systems have been installed at Yosemite National Park, California and Pueblo, Colorado. The systems consist of the following subsystems: collector, storage, transport, hot water, auxiliary energy and controls. This document provides general guidelines which may be utilized in development of detailed installation plans and specifications. In addition, it provides instruction on operation, maintenance and repair of a solar heating and hot water systems.					
17. KEY WORDS			18. DISTRIBUTION STATEMENT UC-59c Unclassified-Unlimited <i>William A. Brooksbank, Jr.</i> WILLIAM A. BROOKSBANK, JR. Mgr, Solar Heating and Cooling Project Office		
19. SECURITY CLASSIF. (of this report) Unclassified		20. SECURITY CLASSIF. (of this page) Unclassified		21. NO. OF PAGES 75	22. PRICE NTIS

TABLE OF CONTENTS

SECTION	TITLE	PAGE
1.0	Introduction	1
2.0	System Description	1
3.0	Installation	3
3.1	Preparation for Installation	4
3.1.1	Step I: Receive Systems Drawings and Specifications	4
3.1.2	Step II: Complete Parts Take Off	4
3.1.3	Step III: Order Standard Parts from Suppliers	5
3.2	Collector Type	5
3.2.1	Integrated Collector	5
3.2.1.1	Checking Tilt Angle and North-South Orientation	6
3.2.1.2	Framing Requirements	6
3.2.1.3	Receiving Collectors	7
3.2.1.4	Hoisting Collectors to the Roof	7
3.2.1.5	Collector Attachment	8
3.2.1.6	Installing Flashing and Caulking	13
3.2.2	Truss-Mounted Collectors	16
3.2.2.1	Checking North-South Orientation	16
3.2.2.2	Installing Truss Foundation Plates	16
3.2.2.3	Installing the Truss Structure	17
3.2.2.4	Receiving Collectors	19
3.2.2.5	Hoisting Collectors to Roof	19
3.2.2.6	Attaching Collectors to Truss	19
3.2.2.7	Installing Flashing and Caulking	19

NOTICE

This report was prepared as an account of work sponsored by the United States Government. Neither the United States nor the United States Department of Energy, nor any of their employees, nor any of their contractors, subcontractors, or their employees, makes any warranty, express or implied, or assumes any legal liability or responsibility for the accuracy, completeness or usefulness of any information, apparatus, product or process disclosed, or represents that its use would not infringe privately owned rights.

DISTRIBUTION OF THIS DOCUMENT IS UNLIMITED

TABLE OF CONTENTS (continued)

SECTION	TITLE	PAGE
3.3	Installing Collector Manifolds	20
3.4	Installing Pumps and Valves	23
3.5	Installing the Expansion Tank	23
3.6	Thermal Storage Installation	26
3.6.1	Site Preparation	27
3.6.2	Receiving Storage Tanks	28
3.6.3	Installing Heat Exchanger	30
3.6.4	Installing Plumbing	31
3.6.5	Installing Tank-Fill Plumbing	32
3.6.6	Installing Control Instrumentation	33
3.6.7	Insulating Tank	36
3.6.8	Interfacing Plumbing with Collectors	37
3.6.9	Filling & Checking Collector Loop for Leaks	38
3.7	Domestic Hot Water Installation	41
3.7.1	Connecting Domestic Water to Thermal Storage	41
3.7.2	Installing Auxiliary Hot Water Storage Tank	42
3.7.3	Connecting Electricity to Auxiliary Hot Water	43
3.7.4	Checking for Hot Water Leaks	43
3.8	Heating System Installation	43
3.8.1	Installing Heat Exchanger Coils	44
3.8.2	Installing Coil Plumbing	46
3.8.3	Checking Heating System for Leaks	47
3.8.4	Installing Auxiliary Heating Systems	48
3.9	Insulate All Piping	48

TABLE OF CONTENTS (continued)

SECTION	TITLE	PAGE
3.10	Controls Installation	49
3.10.1	Installing Differential Controller	50
3.10.2	Installing Temperature Thermostat	52
3.10.3	Installing Motor Controllers	52
3.11	Testing System	54
3.11.1	Testing Electrical Controls	54
3.11.2	Testing Flow Controls	54
3.11.3	Testing Safety Devices	55
3.12	Filling the Thermal Storage Vessel	56
3.13	Balancing Performance	56
4.0	System Operation	57
4.1	Description of System	57
4.2	Nominal System Operating Parameters	61
4.3	Effect of Variations on Performance	62
5.0	Maintenance	62
5.1	Routine and Preventive Maintenance	62
5.2	Trouble Shooting	64
5.3	Unscheduled Maintenance	66
5.4	Safe Installation and Maintenance Procedures	69

LIST OF ILLUSTRATIONS

FIGURE NO.	TITLE	PAGE
3.2-A	Integrated Colt Collector	7
3.2-B	Hoisting Solar Panels to the Roof	8
3.2-C	Integrated Collector Installation	9
3.2-D	Attaching Flashing Adapter	11
3.2-E	Typical Flashing Installation	13
3.2-F	Upper Flashing Installation	14
3.2-G	Lower Flashing Installation	15
3.2-H	Channel Foundation Plates with Attached Support Truss	17
3.2-I	Block Foundation Plates with Attached Support Truss	18
3.2-J	Lower Clip Support Truss Installation	20
3.3-A	Collector Manifold Installation	21
3.3-B	Collector Array Schematic	22
3.5-A	Expansion Tank Installation	24
3.5-B	Alternate Expansion Tank Configuration	25
3.6-A	Subterranean Thermal Storage Installation	29
3.6-B	Above-Ground Thermal Storage Installation	29
3.6-C	Heat Exchanger Installation	30
3.6-D	Typical Manifold Plumbing	31
3.6-E	Temperature Switch/Sensor Installation	34
3.8-A	Plumbing Schematic	44
3.8-B	Liquid-to-Air Heat Exchanger Installation	45
3.10-A	Wiring Diagram	49
3.10-B	Alternate Wiring Diagram	50
3.10-C	Recirculation Pump Sensor Installation	51

1.0 Introduction

The Colt solar system is a space and domestic water heating system based on a collector that was developed by an independent research laboratory. The collector plate has a selective coating and the fluid flow pattern within the plate is designed to allow maximum fluid contact with the plate surface. These two features contribute to making the Colt collector one of the most efficient solar panels presently available. In addition, the Colt collector has the versatility of either being installed directly on rafters as an integrated component of the roof or retrofitted on top of an existing flat or sloped roof.

All other system components delivered are sized and designed to adequately provide for the space and domestic water heating requirements. Although it is true that very few geographic locations can support total solar capability, maximum solar contribution accompanied by a reduction in heating fuel costs can be expected from the Colt system, if it is properly installed according to this manual.

2.0 System Description

The Colt solar system is a closed-loop system utilizing a submerged heat exchanger and a heat collection/transfer medium which is a special mineral oil with paraffinic qualities.

The heat exchanger is immersed in a large thermal storage

vessel which has been sized for this installation. The vessel contains water as a heat storage medium. This water is circulated for use in space heating.

The energy collection and transfer process begins each day as the sun rises and heats the solar collector surface. The system starts up when a specific temperature differential between the collector surface and thermal storage is reached. This solar energy process continues through the day as long as the design temperature differential is exceeded. As the sun recedes, this differential decreases. The energy process, however, continues until the temperature differential drops to its design value. At this point, the energy collection and transfer process ceases until the next morning when the cycle begins again. Sufficient cloud cover may interrupt the collection process by causing the temperature differential to drop below the design value.

Room space heating is accomplished by pumping heated water from the thermal storage vessel through a liquid-to-air heat exchanger which is installed within the forced air ductwork (or through radiators, if so installed). This system operates in the conventional manner using a standard room thermostat. However, because it is necessary to supplement the solar energy system with an auxiliary heat source system, two temperature switches are installed within the thermal storage vessel to determine which system or systems must be used to

fulfill the space heat requirement. Reference to section 4.1 will clarify the temperature switch operating criteria.

Domestic hot water is supplied by a secondary heat exchanger within the thermal storage vessel. City water flows through this heat exchanger before it enters a standard water heater, thus supplying the water heater with hot rather than cold water. If it becomes necessary, the heating element contained within the water heater can serve as a secondary heat source to maintain acceptable water temperature.

The preceding brief description of the Colt solar energy system is intended to familiarize the installer with the basic concepts contained within a solar space and domestic water heating system. A more thorough explanation, along with system schematics, is provided in the installation and operation sections of this manual.

3.0 Installation

The following is a concise and complete guide to the installation of a Colt solar system. Illustrations are provided to help clarify portions which may be unfamiliar to the installer. It is advisable to read the entire installation portion of this manual as a unit, since questions that arise while reading a specific section might possibly be answered in subsequent sections. The installer should also familiarize himself with the safety requirements discussed in section 5.4.

3.1 Preparation for Installation

In order to assure adequate preparation, it is necessary to read all the following steps before actually beginning installation of the system.

3.1.1 Step I: Receive Systems Drawings and Specifications

Colt Inc. will deliver to the contractor, or installer, a data package including all systems drawings, schematics and specifications which are necessary to enable competent installation of this system. The installer should completely familiarize himself with the Colt solar energy system by studying these drawings, schematics and specifications. Every effort should be made by the installer to follow the instructions carefully.

3.1.2 Step II: Complete Parts Take Off

After the initial study phase has been completed, the installer should then carefully read through the parts list on each drawing. It is necessary to become familiar with all parts to be supplied, either by Colt Inc. or by the installer himself, that will be necessary to complete this system installation. Colt will provide, at time of delivery, all system components that are not commonly available to the installer. A partial list of the Colt supplied components might include the following: the solar panels, the differential controller and related sensors, the expansion tank, the motor controllers, the thermal storage tank and heat exchanger, the liquid-to-air

heat exchanger and necessary temperature switches. At the installer's request, Colt Inc. will also supply all system pumps, transformers and the thermostat. The drawings will specify the parts to be supplied by Colt Inc.

3.1.3 Step III: Order Standard Parts from Suppliers

After carefully studying the parts list on each drawing, the installer should be completely familiar with which systems components will be provided as part of the Colt package. At that time, the installer will have to order all remaining components from his own suppliers. Should there be any questions, or should component sizing specifications be necessary, a Colt Customer Service Representative will be available for assistance.

3.2 Collector Type

As was mentioned in the system description, the Colt solar collector is unique in that it may be installed either as an integrated portion of the building roof or mounted on a truss and retrofit to an existing building. The contractor is responsible for predetermining which type of installation has been planned. He should then read the following appropriate section.

3.2.1 Integrated Collector

The following is a summary of the installation procedure which

is necessary to install Colt solar panels as an integrated portion of the building roof.

3.2.1.1 Checking Tilt Angle & North-South Orientation

When the collector array is to be mounted as part of the building roof, it is necessary to construct that portion of the roof at the appropriate pitch to allow for the most efficient collector operation. The standard collector tilt angle is the geographic latitude plus ten degrees. For example, if the latitude is 35° North, then the solar collector should be installed at a 45° angle. It is necessary to orient the collector in a due south position in order to take full advantage of maximum solar insolation. Thus, in the integrated collector installation, it is necessary to orient the roof to accommodate the entire collector surface facing a due south direction. If it is not possible to achieve a due-South orientation, deviations up to 20° may be permitted with a slight loss in efficiency.

3.2.1.2 Framing Requirements

When installing the Colt collector in an integrated configuration, it is recommended that the collector be set so that the eight foot length is oriented parallel to the ground. (See Figure 3.2-A.) In this manner, the collector can be laid across the roof rafters. Either the standard 16"-center rafter or the 24"-center prefabricated roof truss can be

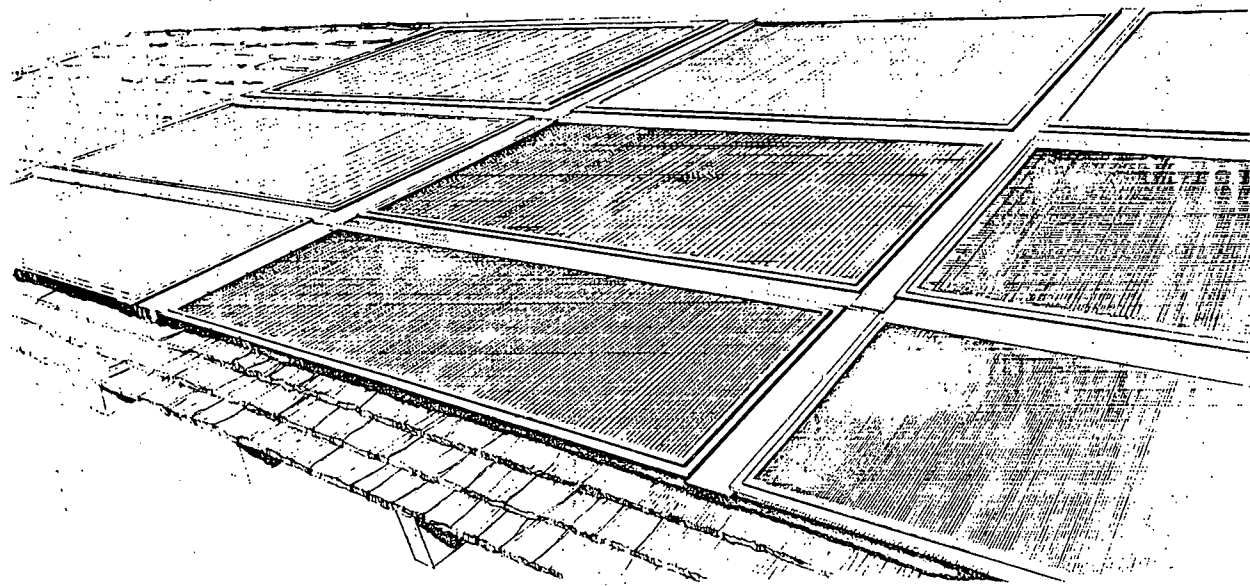

FIG. 3.2 - A INTEGRATED COLT COLLECTOR

accommodated: The Colt collector, when wet, weighs approximately 4.5 lbs. per square foot, and thus it may be necessary to modify the building roof to withstand the extra weight represented by the collector array.

3.2.1.3 Receiving Collectors

The Colt collectors are delivered to the construction site in disposable styrofoam and corrugated cartons. If necessary, they can be stored in these cartons until actual installation is begun. They can be stored flat and can be stacked.

3.2.1.4 Hoisting Collectors to the Roof

It is recommended that a standard ladder, winch and elevator be

used to hoist the solar panel to the building roof. Figure 3.2-B illustrates the use of the ladder winch. The Colt solar collector weighs 100 lbs. and therefore two men only are required for this task. Because the solar panel is being mounted on a roof with a rather steep slope, only one panel at a time should be hoisted and mounted.

3.2.1.5 Collector Attachment

Figure 3.2-C illustrates the correct manner to attach the solar panel to the building rafter or truss member. Colt Inc. will supply the angle clips necessary for installation of the entire array. The recommended distances between solar panels are: (a) a minimum of eight inches between collectors end-to-end, allowing sufficient space for manifolds; (b) a minimum of 3.5 inches

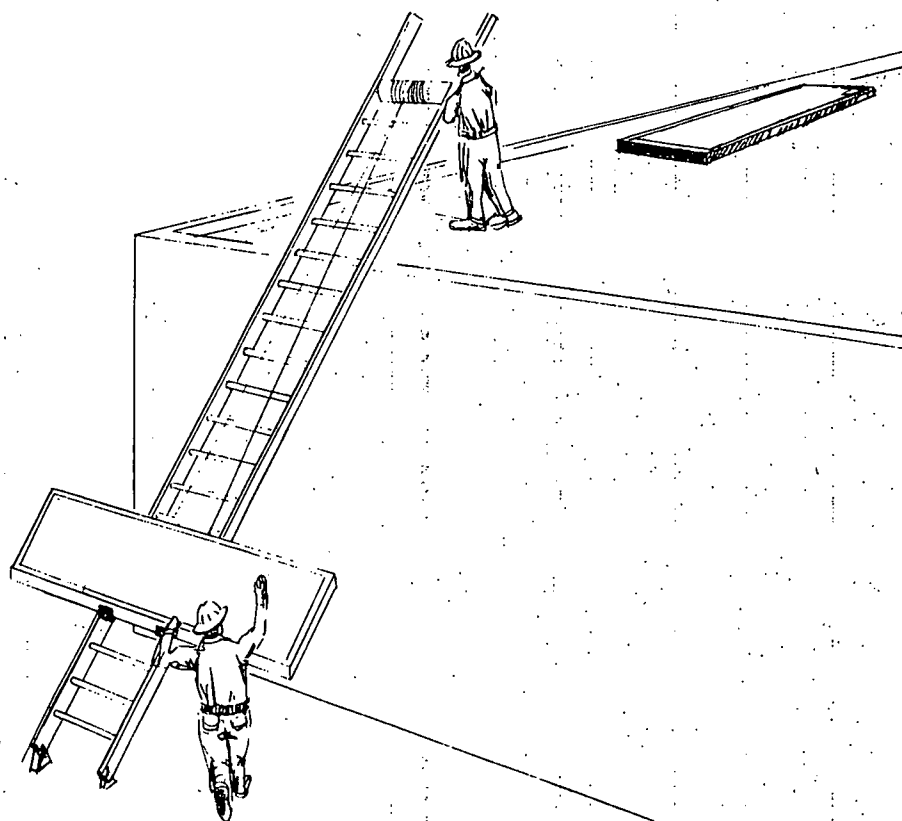
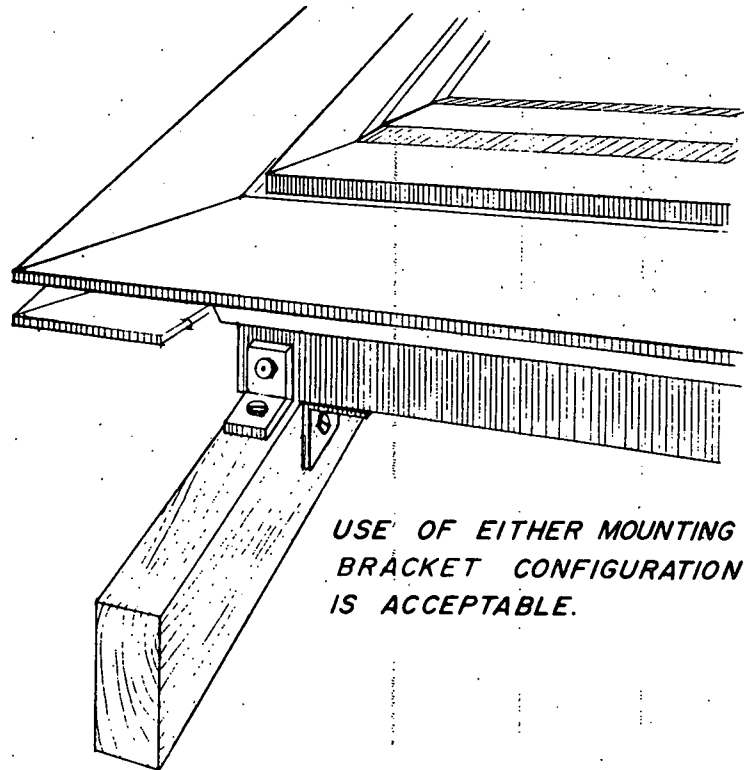

FIG. 3.2 - B HOISTING SOLAR PANELS TO THE ROOF



**FIG. 3.2-C INTEGRATED COLLECTOR
INSTALLATION**

between collectors, side-to-side, providing sufficient area for proper flashing.

It is recommended that the installer begin at the top and install each row of panels proceeding downward along the rafters. This will eliminate the necessity of hoisting each panel over previously installed rows.

To begin actual collector installation, it is necessary for the installer to first determine the position of the top row of collectors. Next, he should snap a level, straight chalk line across all of the rafters at this position, and then install a

support clip on each rafter at the chalk line. The clip may be either nailed or screwed into the rafter or truss member. By referring to paragraph 3.2.1.4, the installer can now hoist the panel to the roof, lift it onto the rafter or truss members and slide it down to rest against the support clips already installed. Then he must bore holes, with an electric hand drill, into the collector housing using the holes in the support clip as a guide. Next, using a hand "pop" riveter, he has to rivet the collector to the support clip with 3/16" diameter rivets. The installer may now choose to either hoist a second collector to the building roof and install it in like manner or attach the upper support clips to the collector housing. This is done by simply sliding the clip down along the rafter or truss member until it contacts the Colt collector housing frame, nailing or screwing it to the rafter member and then once again boring holes into the side of the housing and riveting the clip. The installer proceeds in this manner until he has completed the entire first row across all the rafters. He should then install the flashing adapters to each panel as is illustrated in Figure 3.2-D. The flashing adapter is most easily attached by first lowering the upper lip down into the groove along the top collector surface. By using a rubber mallet, the installer gently taps the lower portion of the flashing adapter, snapping it into place within the collector housing. He should, in this manner, attach the remaining three flashing adapters to each collector.

THE USE OF A RUBBER MALLET
MAY BE REQUIRED.

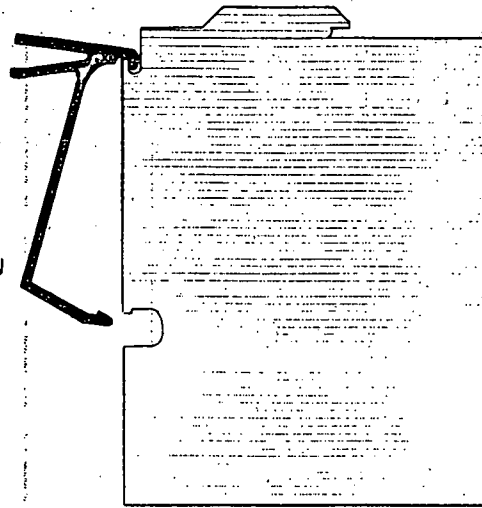

**FIG. 3.2-D ATTACHING FLASHING
ADAPTER**

The installer may now proceed with the installation of the second row of panels. This is accomplished by once again determining the position of the second row, snapping a level, straight chalk line across all of the rafter or truss members at this position, and then once again nailing or screwing the collector support clips to the rafter or truss member at these locations. Because the second row of collectors will be installed at a lower portion along the roof, there will be two minor changes in the installation procedure that should be observed. Before hoisting the panels to the roof, it is first necessary to install the upper flashing adapter section. This is done on the ground. (Assuming that the collector panels

are installed to within 3.5 or 4 inches of each other, there would be inadequate room to tap the flashing adapter into place after the panels are placed into position on the roof.) Next, the installer can hoist the collector with the attached flashing adapter section to the roof. He will once again lift it from the ladder onto the rafter and then slide it up to the collector clips already installed. After lifting the collector over the clips, he can lay it on the rafter and slide it back down until it rests against the clips. The second change in procedure will be observed here. Because there is very little room in between collectors, it will be very difficult to install the upper support clip in the same manner as the clip installed on the first row of collectors. Therefore, these clips should be installed from underneath the collector and this is also shown in Figure 3.2-C. The installer slides the collector clip upward along the rafter until it contacts the bottom of the collector housing and then he either nails or screws the clip to the rafter member. Now, he once again bores holes into the housing using the holes in the clip as a guide and then rivets the clip to the housing. He proceeds in like manner with the remaining collectors in the second row. To complete the second row installation, the installer attaches the remaining three pieces of the flashing adapter to each collector.

All other rows within the collector array are to be installed

following the same procedures described for the second row of collectors.

3.2.1.6 Installing Flashing and Caulking

The contractor should purchase 22 or 24 gauge galvanized steel or anodized aluminum flashing material. This material should be sheared to the proper width and length and, for galvanized steel only, it should be painted before beginning installation.

Figure 3.2-E shows the correct method of installing the flashing. It is necessary to first install the flashing sections between the long sides of the collector panels. These flashing sections slide into the flashing adapters. They must be cut long enough to overlap at the ends of each collector. The flashing that will be installed along the upper portion of

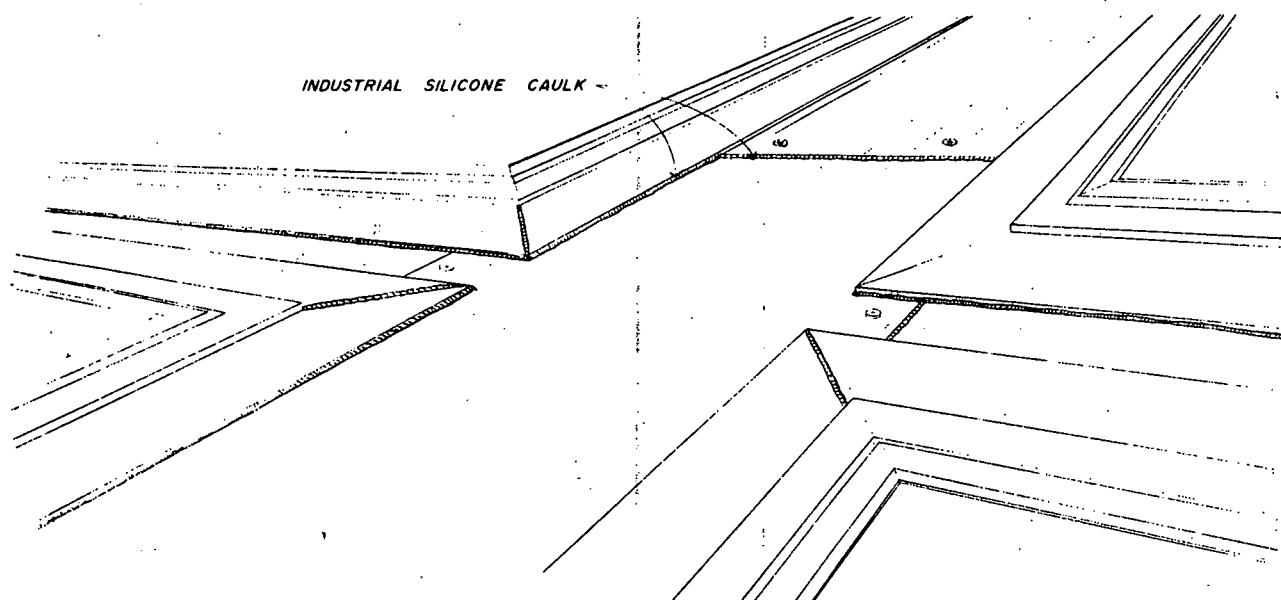

FIG. 3.2-E TYPICAL FLASHING INSTALLATION

the top row of collectors must be bent and installed according to Figure 2.3-F. By applying the correct obtuse angle to this piece of flashing, proper water runoff can be assured. The flashing sections along the bottom edge of the collector array can now be installed. Figure 3.2-G shows how these flashing sections should be bent and interfaced with the roof.

Now the flashing sections between the short sides, or ends, of the collector may be installed. If more than one length of these sections are required, the installer should make sure that the upper piece always overlaps the adjacent piece below.

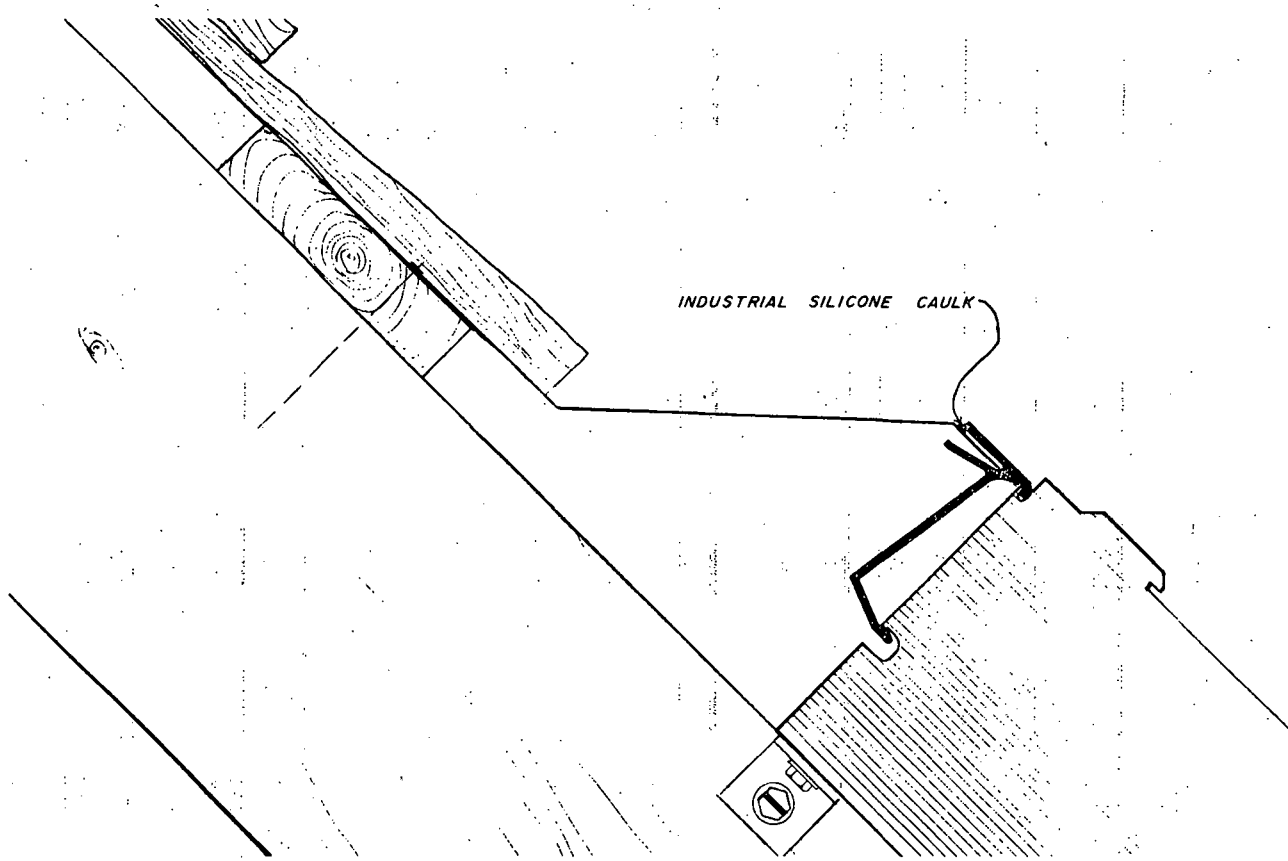

FIG. 3.2-F UPPER FLASHING INSTALLATION

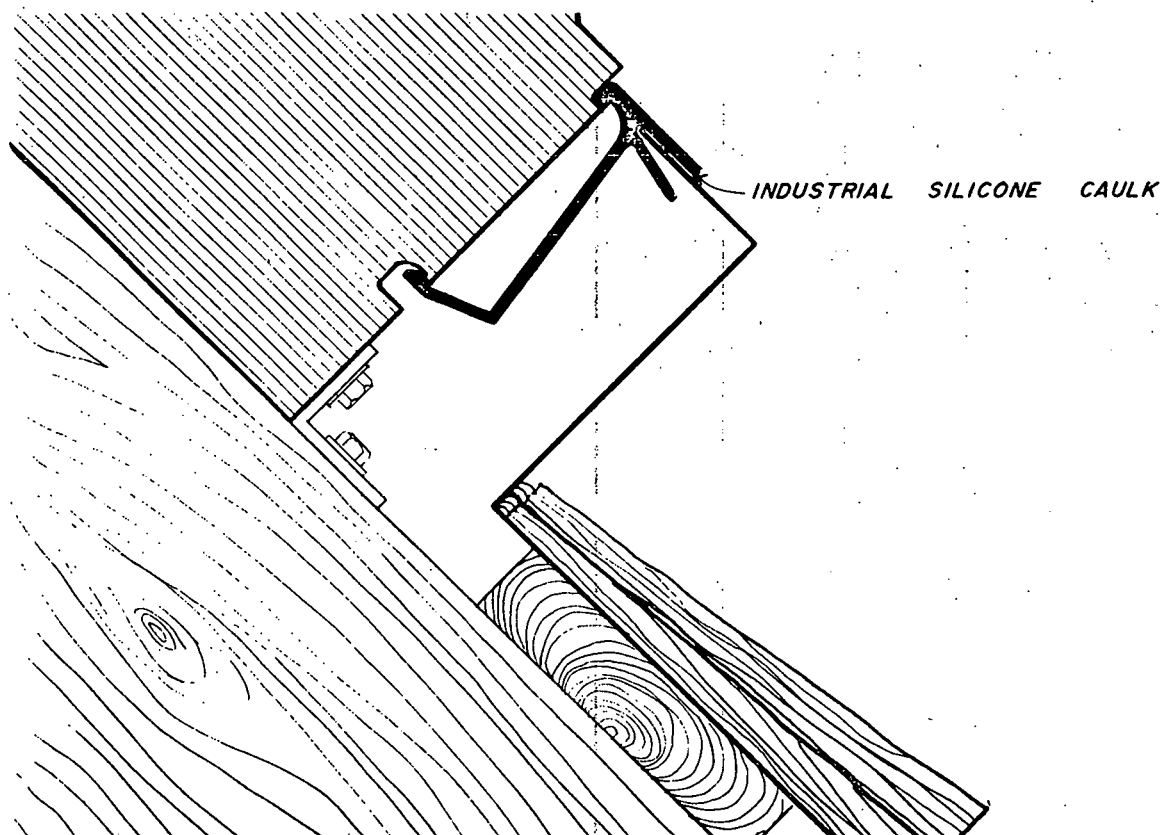

FIG. 3.2-G LOWER FLASHING INSTALLATION

The installer should study carefully Figure 3.2-E which illustrates the correct flashing installation procedure. Colt Inc. recommends "pop" riveting all flashing junctions.

Flashing requirements are met when all flashing junctions, including rivets and adapter mitered edges, are properly and thoroughly caulked with any of the commercial grade silicone rubber compounds designed for this purpose.

The contractor may choose instead to install flashing immediately following the installation of each row of collectors within the array. This method may be preferable when a very large array of collectors is being installed.

3.2.2 Truss-Mounted Collectors

If the solar collector is being retrofit to an existing building roof, truss members are usually required to provide the proper collector surface angle. Some of the following steps are identical to those described in the preceding sections.

3.2.2.1 Checking North-South Orientation

It is necessary to make an accurate determination of North-South orientation in order to assure proper collector installation. The collectors should then be installed in a manner that takes full advantage of the space available and still maintains a consistent array pattern. Difficult installation patterns should be avoided; for example, a row of eight collectors followed by a row of two or three. To avoid installation problems, Colt Inc. suggests that the installer use Colt's design service provided at a modest engineering cost.

3.2.2.2 Installing Truss Foundation Plates

The use of 16-gauge aluminum channels as the truss foundation plate member is recommended, spaced as shown in Figure 3.2-H. An alternate truss foundation plate of treated wood can also be used as Figure 3.2-I illustrates. They should be fastened with lag bolts to each rafter they cross. It is important that the installer thoroughly seal each lag bolt with roofing cement before attaching the collector trusses. The channels must be installed parallel to each other on 19" centers, and

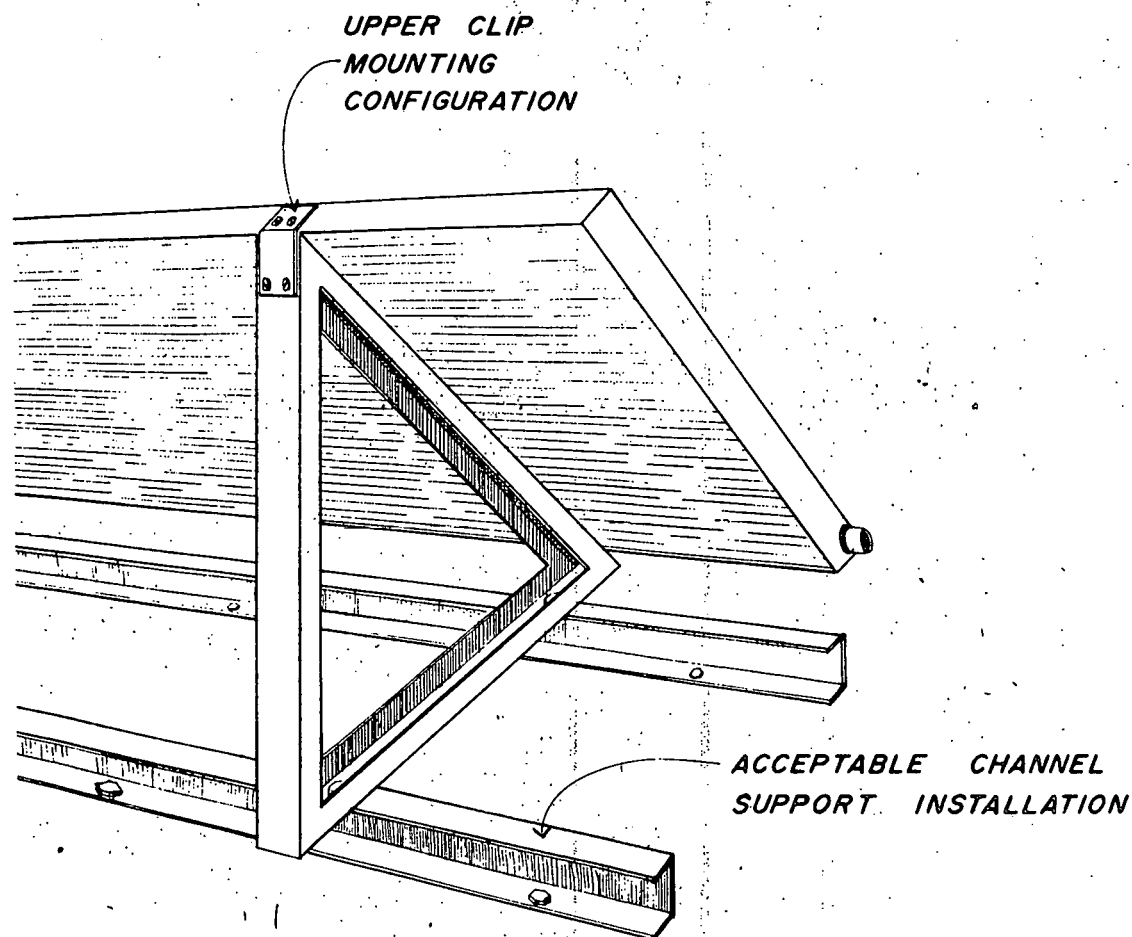

FIG. 3.2-H CHANNEL FOUNDATION PLATES WITH ATTACHED SUPPORT TRUSS

they must be level, so low portions of the roof have to be built up. Care must be taken to provide the correct distance between each row of collectors in the array in order to prevent any row of collectors from casting shadows on the next row. Colt Inc. provides engineering and architectural integration service in this area, if requested.

3.2.2.3 Installing the Truss Structure

The collector truss structure will be installed as illustrated in either Figure 3.2-H or 3.2-I. It is recommended that the

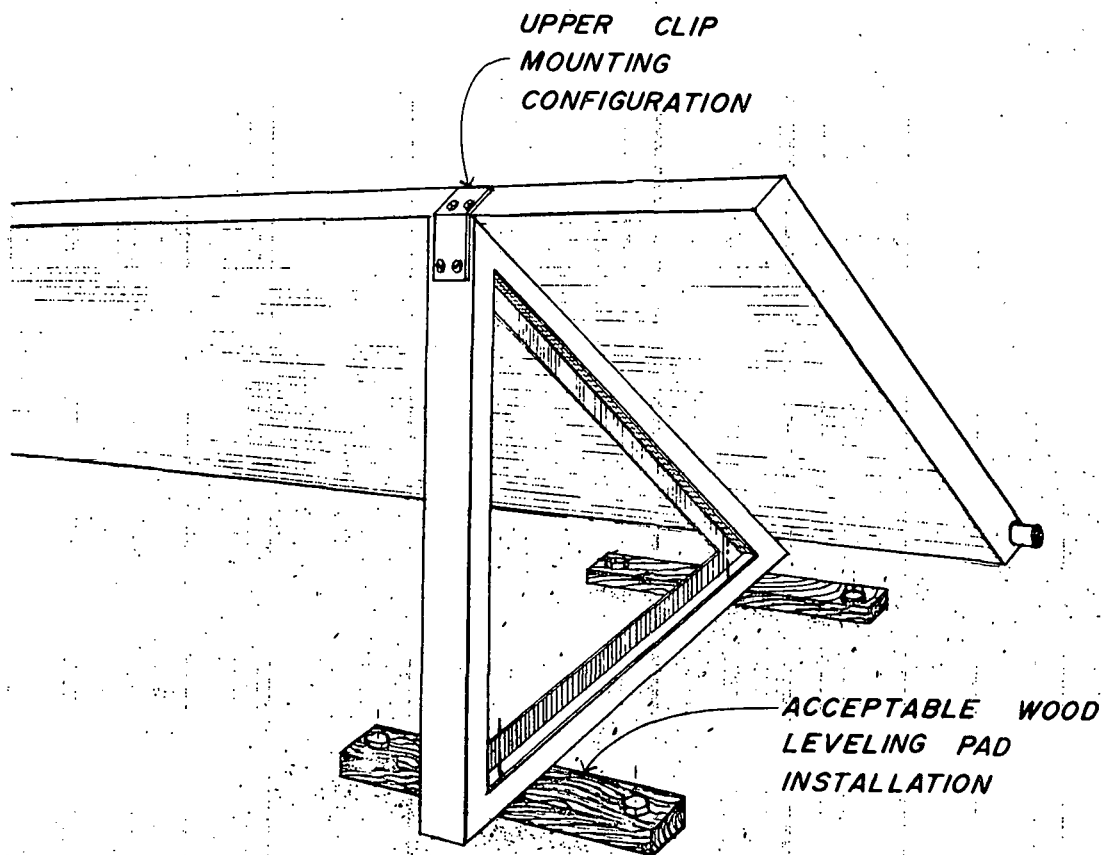

FIG. 3.2-1 BLOCK FOUNDATION PLATES WITH ATTACHED SUPPORT TRUSS

truss member be installed to allow a collector overhang of one foot on each end. The trusses should be spaced so that there is a minimum of eight inches between collector ends. This provides adequate room for collector manifolding. All Colt supplied collector trusses are pre-bored, so the installer has only to place them on top of the truss foundation channels, mark the hole positions and bore the holes through the channel with an electric hand drill. Colt Inc. recommends using 3/8" machine bolts and nuts to attach the collector trusses to the

foundation channels. If wood foundation plates are used, 3/8" lag bolts are recommended. It is necessary, however, to seal these lag bolts with roofing cement.

3.2.2.4 Receiving Collectors

Review Section 3.2.1.3.

3.2.2.5 Hoisting Collectors to Roof

Review Section 3.2.1.4.

3.2.2.6 Attaching Collectors to Truss

Each collector truss has a collector support clip welded along the lower front edge. Colt Inc. supplies all remaining loose support and angle clips necessary to complete the installation. Two angle clips have to be riveted to the collector housing wall. Next, the installer places the collector on two support trusses and slides it down until the two angle clips engage the two support clips that are welded to the trusses. With the bored holes in alignment, the installer secures the collector with #10 self-tapping screws. Figure 3.2-J illustrates how this is done. Figure 3.2-H or 3.2-I shows how clips are riveted to the upper portion of the collector housing and the support truss.

3.2.2.7 Installing Flashing and Caulking

This is an optional installation available to the contractor.

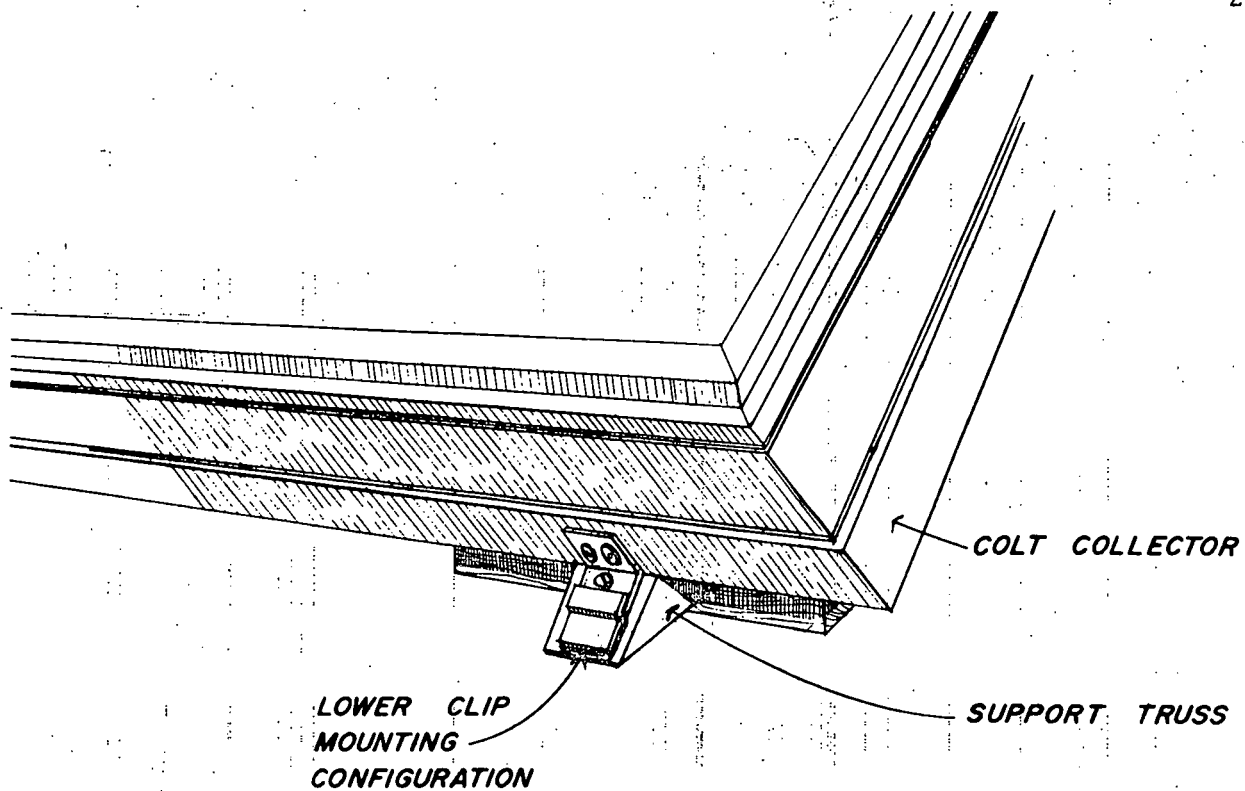
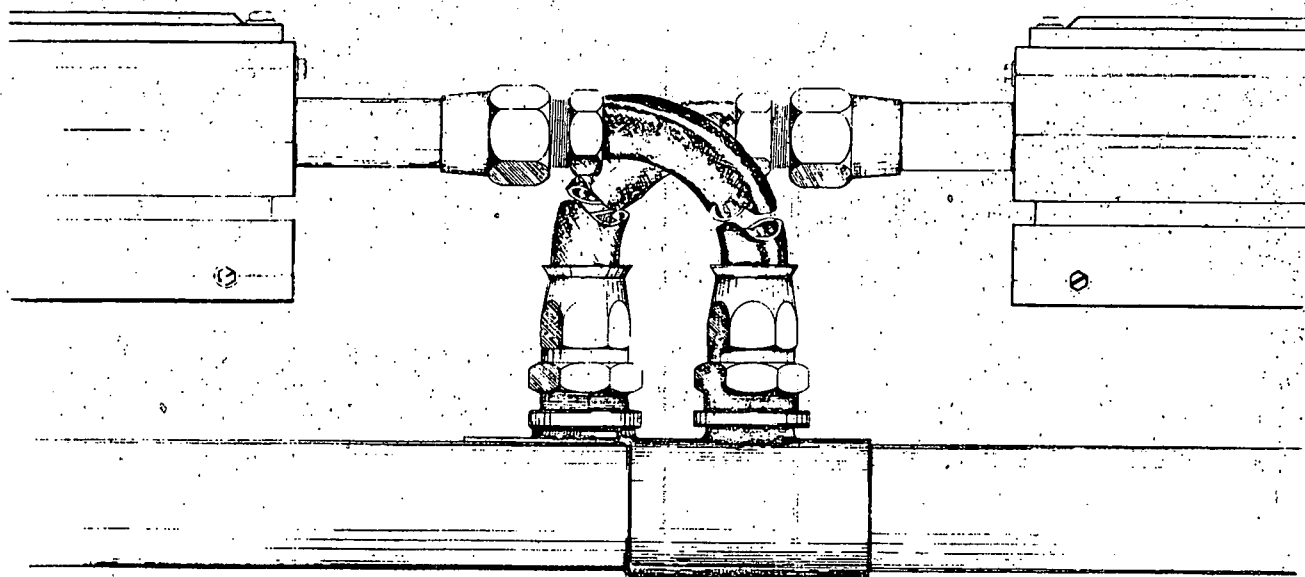

**FIG. 3.2 - J LOWER CLIP SUPPORT TRUSS
INSTALLATION**

After all of the collector manifolding has been finished, the installer may choose, for aesthetic purposes, to cover the area between the ends of adjacent collectors by using flashing similar to that used and described in section 3.2.1.6.

3.3 Installing Collector Manifolds

Colt Inc. uses one-foot sections of stainless steel-braided teflon tubing as a flexible link between the collector plate and the collector manifold. Figure 3.3-A illustrates the proper installation of this linkage. One end of the flexible tubing is supplied with a standard male pipe thread fitting which screws into either a threaded tee off of the manifold



**FIG. 3.3-A COLLECTOR MANIFOLD
INSTALLATION**

or into a threaded adapter that has been soldered into a non-threaded tee. The other end of the teflon hose is joined to the collector plate with a standard compression fitting. This fitting is secured while using lubricating grease to prevent improper ferrule compression. Great care should be exercised in fastening this fitting to the aluminum manifold extending from the collector so that leak-tight integrity may be assured. The collector is properly manifolded when the heat transfer fluid arriving from thermal storage enters the collector through the lower manifold and exits the collector at the opposite upper end.

In a large collector array, so that the entire array operates with a balanced fluid flow rate, it is necessary to install valves in each feeder manifold serving a row of collectors. Figure 3.3-B, an array schematic, illustrates how this is accomplished. By installing thermowells on each collector row return line and by placing a thermometer in each thermowell, the entire array is balanced by either opening or closing each corresponding valve until all thermometers read the same.

It is necessary to install a vent valve on each returning manifold at the point where the last collector in each row joins the return manifold. This valve is used to remove air from the system during the filling process, and should be the highest point in each row of collectors. The installer may

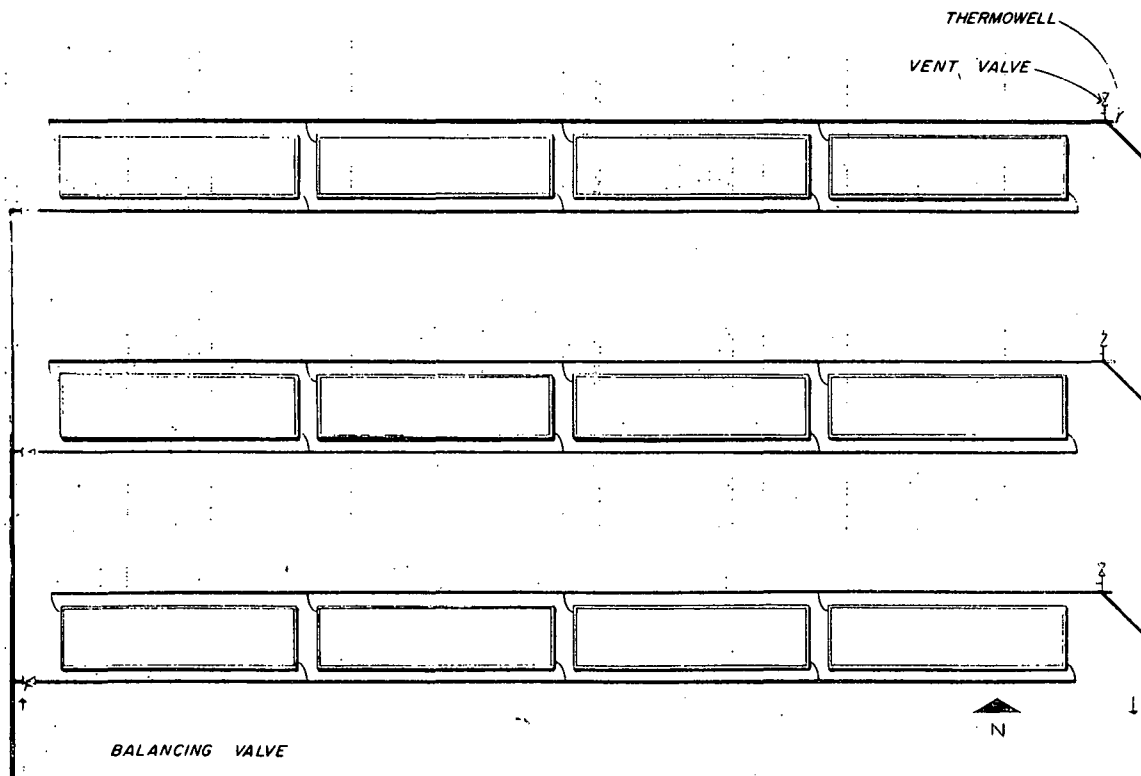

FIG. 3.3 - B COLLECTOR ARRAY SCHEMATIC

also choose to put in a drain valve on the return manifold, although this valve should be at the lowest point in each row.

Please note:

COLT INC. RECOMMENDS ONLY THE USE OF 95/5 SOLDER FOR ALL SOLDERED CONNECTIONS IN THE COLLECTOR HEAT TRANSFER FLUID LOOP. USE OF A LOWER TEMPERATURE SOLDER MAY RESULT IN MELTED JOINTS WHEN THE CIRCULATION FLUID IS HOT.

3.4 Installing Pumps and Valves

Standard competent plumbing practice should be observed during the installation of all system pumps and valves. It is recommended that unions are used for the installation of each pump to facilitate servicing. It is also recommended that ball valves supplied with solder fittings be used for all in-line flow applications.

3.5 Installing the Expansion Tank

Colt Inc. supplies the proper size expansion tank for each installation. One of two types of expansion tanks is used, depending on the size of the collector array. Figures 3.5-A and 3.5-B illustrate how either tank is installed in its respective system. The tank in Figure 3.5-A is a static tank. That is, collector heat transfer fluid does not flow through the tank as it circuits the heat collecting loop, thus avoiding a hot oil/air interface. It is important to note that there

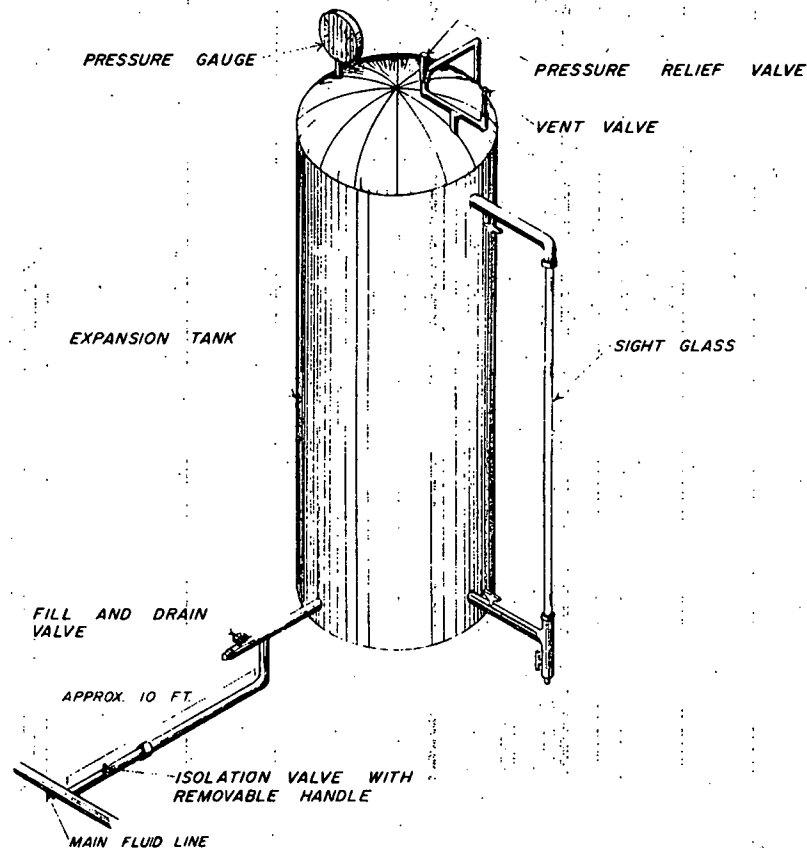

FIG. 3.5-A EXPANSION TANK INSTALLATION

should never be a hot oil/air interface anywhere in the heat collection/transfer loop. This is explained in a later section, 5.2. The tank in Figure 3.5-B contains a pressurized diaphragm. It is a static tank also, since the collector fluid does not circulate through the tank. In this case, the pressurized diaphragm continuously assures that there will not be a hot oil/air interface. In both Figures 3.5-A and 3.5-B, the expansion tank has been installed on the suction side of the fluid pump to facilitate fitting the system with collector fluid.

Figure 3.5-A illustrates a standard expansion tank configura-

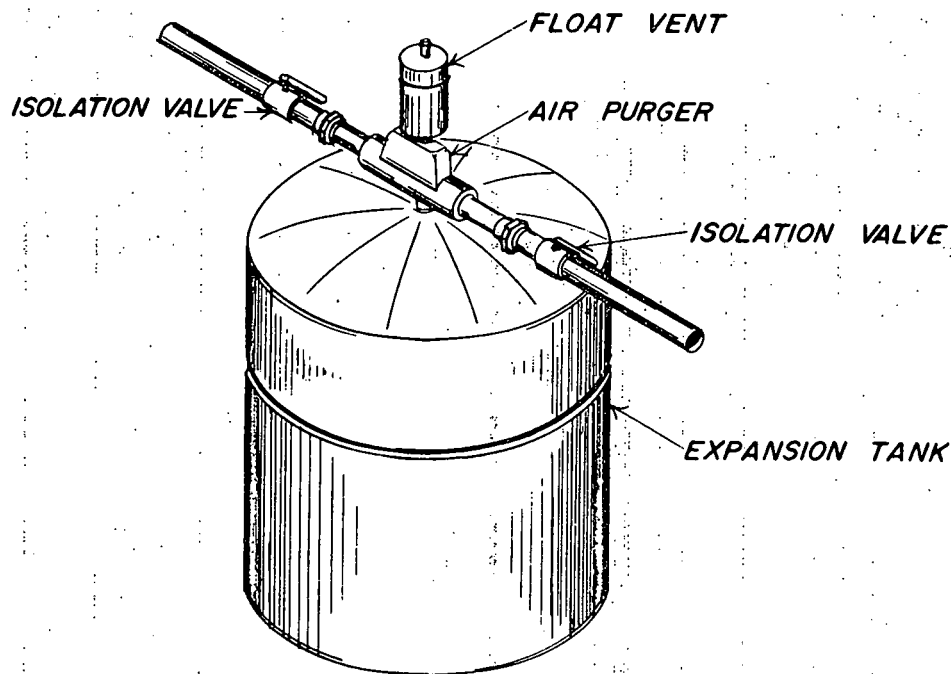

FIG. 3.5-B ALTERNATE EXPANSION TANK CONFIGURATION

tion. It should be placed so that there is a minimum of ten feet of 1/2" copper tubing connecting an opening tapped near the lower end of the expansion tank with the main heat transfer loop. It is important to install a fill and drain valve in this connecting line some place near the expansion tank. Again, it is important that all soldering is done with 95/5 solder composition. Openings tapped on the top of the expansion tank provide access to a pressure gauge, pressure relief valve and a vent valve for capping or purging the system. The relief valve should be vented to a holding vessel. Colt Inc. also supplies fittings to accommodate the installation of a sight glass.

Figure 3.5-B illustrates the alternate expansion tank installation specifically designed for the Colt solar system. It includes a diaphragm, is charged with twelve pounds of air, and has an air purger and a float vent. The air purger is installed in-line and the float vent allows entrapped air to bleed off as it accumulates. This assembly should be installed using two unions to facilitate complete removal during pressure testing. In this configuration, it is necessary to install a system drain and fill valve directly from an in-line tee. The expansion tank must be installed near a vertical support, either wall or shelf frame, so that it may be strapped to or mounted on that vertical support.

3.6 Thermal Storage Installation

In almost all geographic locations, it is necessary to provide adequate thermal storage capability. As heat energy is absorbed by the collector fluid from the solar panels, it is transferred from the fluid to the water in the fiberglass thermal storage vessel through a flat plate heat exchanger, which is inside the thermal storage vessel. Both the heat exchanger and thermal storage vessel are sized for this installation. The purpose of the thermal storage vessel is to meet both the system space and water heat requirements during periods when the sun is not providing insolation to the solar panels; that is, at night or during inclement weather conditions. The thermal storage capability easily and adequately provides all

heating requirements during the night and it is designed to provide for extended periods of inclement weather. While it is expected that there is heat storage capacity for periods up to four or five consecutive days with little or no insolation, each installation's requirements depend on the number of people using the system and their individual heat needs.

3.6.1 Site Preparation

The contractor should decide as part of the original construction plans if he wants to accommodate a subterranean thermal storage installation. If he does, it is necessary to excavate a hole large enough to hold the thermal storage vessel.

(Specific vessel dimensions can be obtained from Colt Inc.)

After the hole is dug, the bottom should be leveled to accommodate the installation of the storage vessel which will be discussed in Section 3.6.7.

If the contractor chooses an above-ground thermal storage installation, Colt Inc. recommends that a small shed-like structure on a concrete slab be built to accommodate the vessel. The support cradles are placed in position so that the vessel overhangs the two outermost cradles by no more than 18".

An alternative to the shed structure is to allow the thermal storage vessel to stand in the corner of an existing building

(such as a garage). If the contractor chooses to install the thermal storage vessel in an existing garage or similar type structure, the vessel will be delivered with the insulation already applied. (See Figure 3.6-C.)

3.6.2 Receiving Storage Tanks

The contractor has the option to receive the storage tank completely pre-assembled already containing the heat exchangers, all plumbing stubs, fixtures and control instrumentation. In this case, the thermal storage vessel will be delivered with insulation already applied. The contractor then only has to lower it into the hole and make sure to set it down so that the access holes are pointed straight upward. Next, he packs loose dirt or sand around the vessel base to prevent it from rolling. If this vessel is to be installed in an above-ground shed structure, it will be delivered without insulation. Figures 3.6-A and 3.6-B illustrate these installations. The installer can then disregard section 3.6.3 of this manual.

If the contractor chooses to install the heat exchanger himself, he will receive all system components that are necessary to complete the installation of the thermal storage vessel. The vessel is delivered with fittings in place so that all plumbing and control instrumentation may easily be installed. These steps are described in subsequent sections.

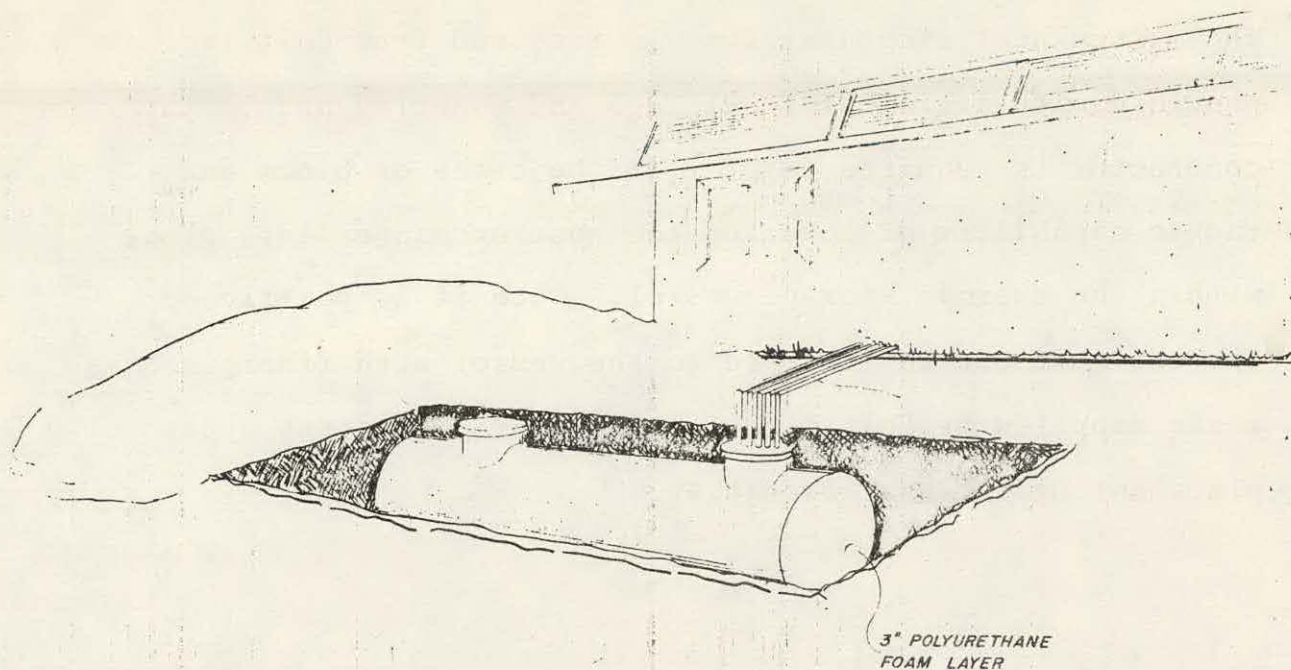

FIG. 3.6 - A SUBTERRANEAN THERMAL STORAGE
INSTALLATION

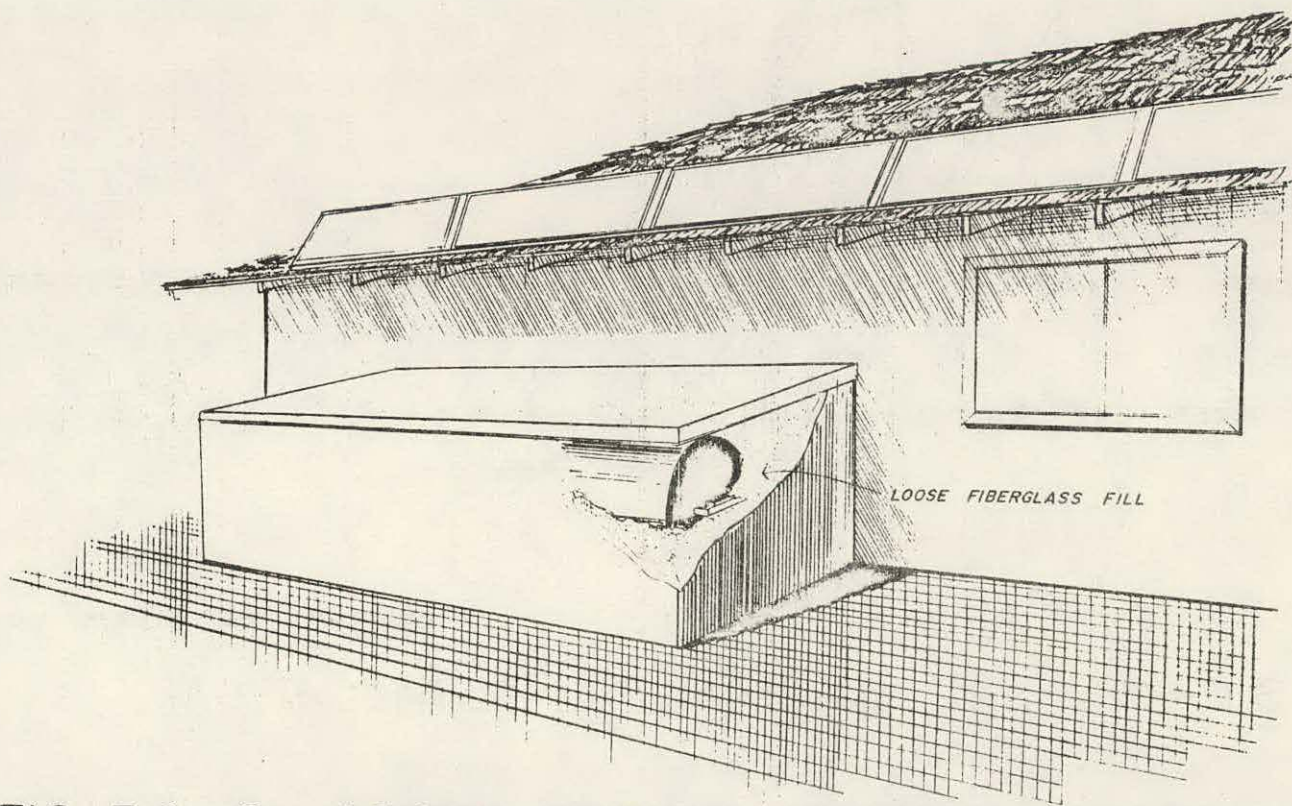

FIG. 3.6 - B ABOVE-GROUND THERMAL STORAGE
INSTALLATION

3.6.3 Installing Heat Exchanger

The system heat exchanger that is received from Colt Inc. is provided with stainless steel legs and mounting pads. The contractor is required to provide the crane or block and tackle capability of lowering the heat exchanger into place within the thermal storage vessel. Once it is positioned correctly it can be fastened to the vessel with fiberglass and resin supplied by Colt Inc. Figure 3.6-C illustrates correct placement of the heat exchanger.

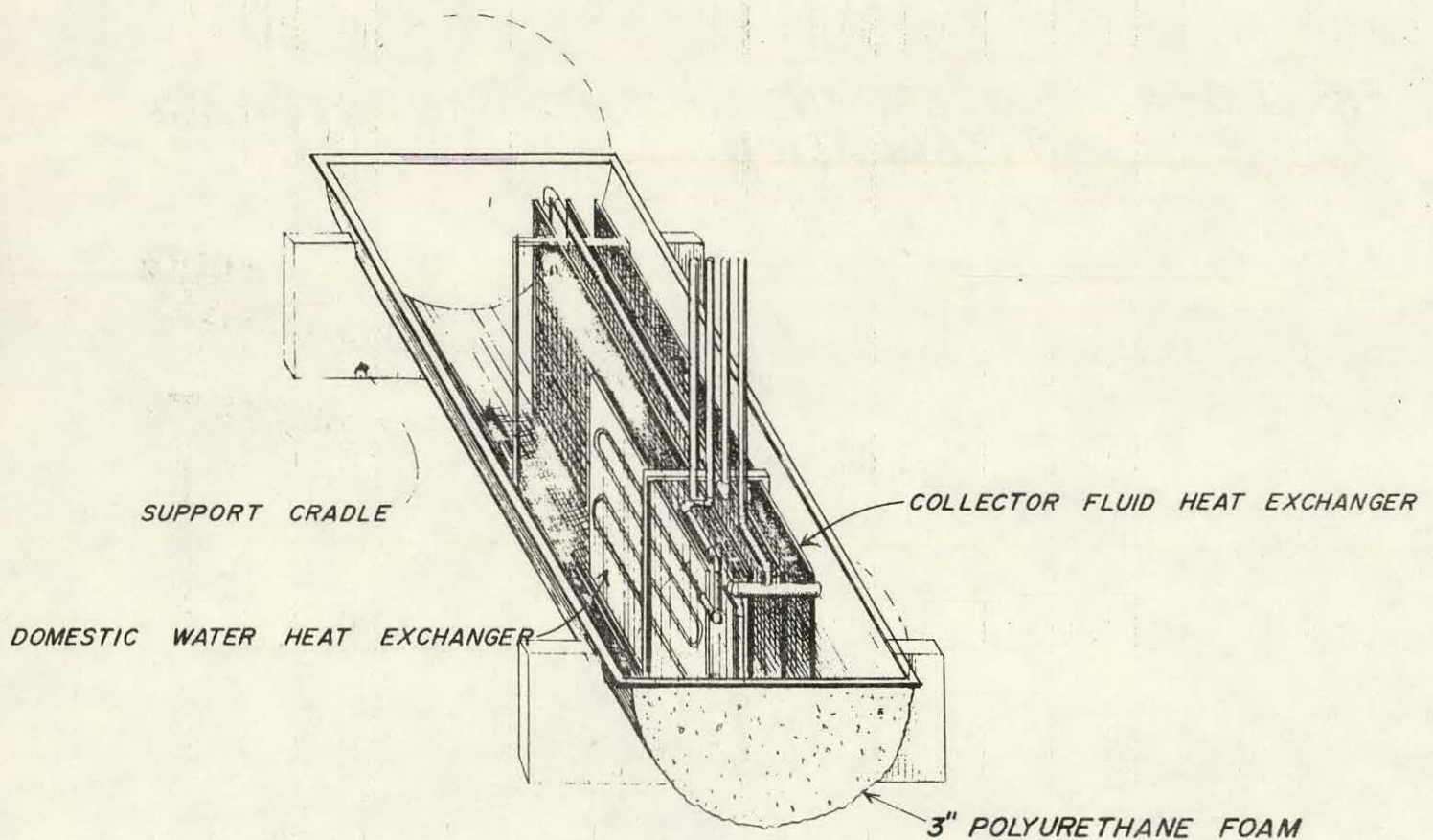

FIG. 3.6-C HEAT EXCHANGER INSTALLATION

3.6.4 Installing Plumbing

Figures 3.6-A and 3.6-D indicate two methods of installing the necessary interior plumbing.

One method depicts all plumbing manifolding entering and exiting the thermal storage vessel through one of the two openings provided at the top. This method is used if the vessel is installed in a subterranean location. For ease of handling, the installer should stub off all manifolding at a convenient length, but long enough to facilitate later above-ground connections.

If the thermal storage vessel is installed above the ground,

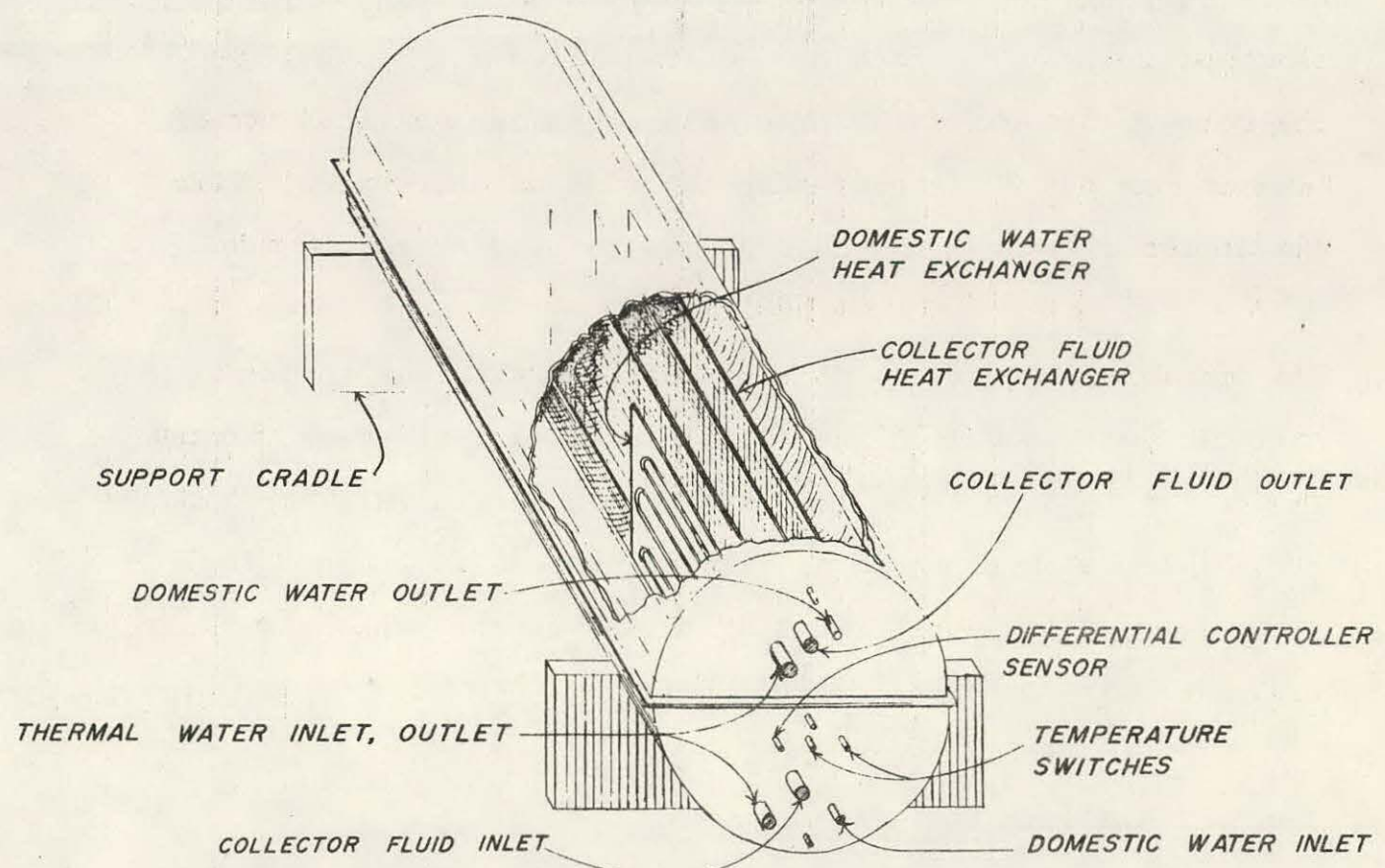

FIG. 3.6-D TYPICAL MANIFOLD PLUMBING

the contractor should refer to Figure 3.6-D for installation details. This figure indicates that all manifolding enters and exits the thermal storage vessel through copper stubs that have been molded in place in one of the end walls. This more readily accommodates circulator pump capability. After the heat exchanger manifolding has been completed, the installer should check his work for leaks. Section 3.6.9 provides specific instructions on this.

The contractor should note that the heat exchanger supplied by Colt Inc. actually contains two separate heat exchanging units: (1) a main exchanger for the thermal collection and transfer fluid loop system, and (2) a secondary heat exchanger for domestic hot water. Each can be identified very readily by the size of its manifold. The main exchanger manifold varies between one and 2" depending on the size of the system, while the domestic water manifold accommodates a 3/4" copper tube.

The installer should assemble the necessary tubing to the domestic water manifold and, if it is to exit the tank through the top, he should stub these tubes at a convenient length to facilitate later connection. If the tank is to be installed above ground, he should run 3/4" tubing to the stubs that are molded-in-place in the end wall.

3.6.5 Installing Tank-Fill Plumbing

The interior tank-fill plumbing for an above-ground thermal

storage vessel is supplied by the copper stub that has been fiberglassed in-place at one end wall of the vessel. The installer runs 3/4" copper tubing from the exterior portion of the copper stub to the outside of the structure which houses the thermal storage vessel. He next installs a globe valve in the exterior tank-fill line. This globe valve is later connected to the domestic water inlet supply, after it has been installed according to Section 3.7.

If the contractor chooses a subterranean thermal storage vessel installation, the tank-fill plumbing is accommodated by simply supplying a length of 3/4" copper tubing running from a position about 18" above the bottom of the tank, through the top coffer, to a convenient height above the tank, where it is stubbed to facilitate the above-ground installation of the globe valve, as explained earlier in this section.

3.6.6 Installing Control Instrumentation

Colt Inc. supplies two temperature switches as part of the instrumentation control for the space heating requirements. One switch is a normally-open switch; the other, a normally-closed switch. Also supplied is a thermal sensor which is used as part of the differential control for the heat collection/transfer fluid pump. In the lower half of the end wall of the thermal storage vessel, 1/2" fittings are fiberglassed in place. Using normal installation methods which

successfully prevent any water leakage, the three temperature switches are placed into these fittings. Figure 3.6-E illustrates this installation. Eighteen-gauge, two-conductor stranded wire is connected to each temperature sensor and is run through standard electrical conduit (for above-ground installation), or through PVC tubing (recommended for subterranean installation). The wire is connected to a junction box located either on the outside of the thermal storage enclosure or some other place above ground where it is convenient to service.

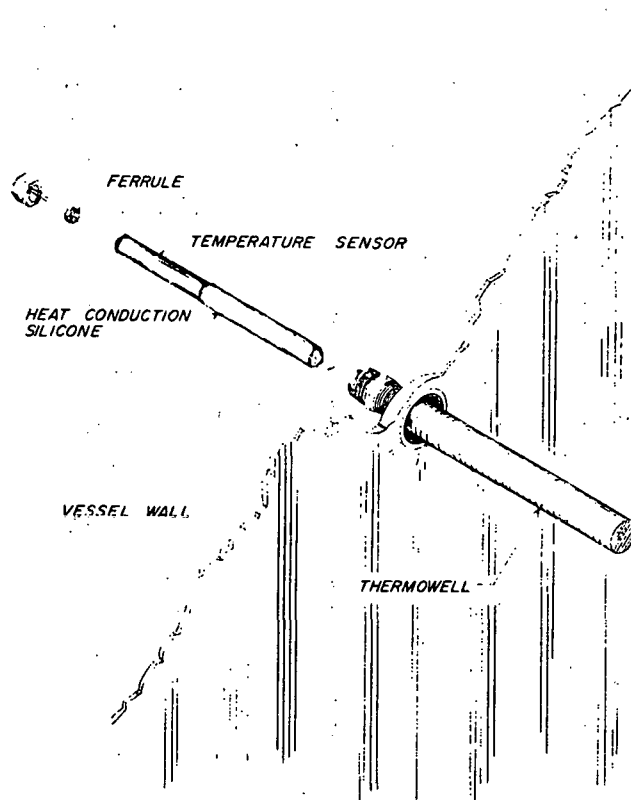

**FIG. 3.6 - E TEMPERATURE SWITCH / SENSOR
INSTALLATION**

The contractor may choose to install a standard float switch to control the water level within the thermal storage vessel. The switch can be strapped to the tank-fill line entering the vessel through one of the top access holes. The switch should be converted from a normally-open to normally-closed component to activate an indicator light when the water level drops below the height pre-set at the float switch. This will normally maintain a water level to within six inches of the top of the storage vessel.

If the contractor desires a visual inspection method, he can simply provide an eight-foot wood dowel marked so that when one end rests on the bottom of the vessel, it will indicate a water level which is 6" from the top of the tank.

After completing all interior plumbing requirements, the installer should fiberglass the top half to the bottom half of the thermal storage vessel. A kit with specific instructions is provided by Colt Inc.

After sufficient time has been allowed for the fiberglass resin to set and dry, the installer should test the thermal storage vessel for leaks. To do this, he must first cap all openings in the side of the vessel and then fill the vessel with water. Following this, he should carefully inspect each brass/fiberglass interface and the entire tank seam. If a

leak is found, it is necessary to empty the vessel and refiber-glass the area around the leak. After the water is drained from the vessel and all necessary repairs are made, the vessel should be cleaned thoroughly. Note: It may be necessary to retest the tank after repairing it.

3.6.7 Insulating Tank

After the tank has been checked for leaks, the insulation can be installed. For a subterranean thermal storage vessel installation, the contractor is responsible for obtaining the polyurethane foam application to adequately insulate the vessel. Colt Inc. recommends a three-inch minimum insulation layer applied all around the vessel.

As mentioned earlier in this section, the contractor can choose between two options available to him. One is to purchase a thermal storage vessel that is completely pre-assembled with all necessary components; the other option is to purchase the vessel in two halves and assemble all of the components himself. The preceding paragraphs have addressed mostly the latter option. However, for a subterranean thermal storage vessel installation, if the contractor chooses the first option, the vessel is delivered with the polyurethane foam insulation already applied. The contractor then simply lowers the tank into the prepared hole, taking care not to disturb the foam layer. After positioning the vessel correctly, he should

then pack loose dirt or sand around the base to prevent it from shifting or rolling. Polyurethane foam need not be used as insulation for above-ground thermal storage vessel installations.

Colt recommends that after all necessary plumbing is completed and the tank is tested for leaks, the structure surrounding the vessel is completely filled with loose fiberglass insulation, the type that is normally blown between ceiling and roof in standard housing construction. To accommodate this type of insulation, the enclosing structure is sized to allow one foot of space on all sides of the thermal storage vessel. (See Figure 3.6-B.)

3.6.8 Interfacing Plumbing with Collectors

The installer next assembles the thermal collection/transfer loop. This loop includes the fluid pump, the expansion tank and the solar panels, in addition to the heat exchanger. All collector manifolding should already be installed according to Section 3.3. In addition, a by-pass containing an in-line oil filter and flow control valves is to be provided on the suction side of the pump. (As previously mentioned, Colt Inc. recommends the use of only one type of solder, the 95/5 composition.) The heat transfer loop is completed by connecting (1) the expansion tank and fluid pump in line to the exit manifold of the heat exchanger contained within the

thermal storage vessel, and (2) the return collector manifold in-line to the entrance manifold of the heat exchanger. Colt Inc. recommends installing a ball valve in line between the fluid pump and the collectors to serve as the throttling valve, although the balancing valves already installed on the collector manifolds accomplish the same purpose. A single throttling valve to control the overall flow, however, is easier to operate.

3.6.9 Filling and Checking Collector Loop for Leaks

If the installer has equipment available to detect freon leaks, the best method of checking the heat transfer loop for leaks is to pressurize the system with freon. However, a number of very important precautionary procedures should be followed before attempting this test. First, this test should be conducted before the collector manifolds are connected to the rest of the fluid loop. To do this, the installer should stub the feeder manifolds and solder normal end caps in place to close up the loop. Second, (1) he should isolate the expansion tank and its accompanying pressure gauge and pressure relief valve, if it is the type of tank illustrated in Figure 3.5-A; or (2) if it is the type of tank illustrated in Figure 3.5-B, he should remove it at the unions and substitute a short piece of copper tubing in its place. Third, the fluid pump should also be isolated in a similar manner, that is, removed at the unions and replaced by a short piece of copper tubing with a

tee fitting and a valve that allows for system pressurization. The installer should now pressurize the system with freon and check the line with his leak detector. After this system is checked and found free of leaks, the installer should purge off all freon and reconnect the collector feeder manifolds, pump and expansion tank to complete the system loop. The collector manifolds, pump and expansion tank should now be checked by pressurizing the system with air to 40 or 45 psi. All mechanical and soldered connections in the collector manifolding, all unions flanking the system pump and expansion tank and all fittings associated with the pressure relief valve and pressure gauge should now be checked with a soap and water solution. When this is completed the relief valve operation may be tested by slowly increasing the air pressure to 50 psi, at which point the valve should open.

If the installer does not have freon leak detecting equipment available, he may check the entire heat transfer loop for leaks by pressurizing it with air as described above. After the pressure is raised to between 40 and 45 psi, he should check all soldered and threaded connections with a soap and water solution.

After the entire heat collection/transfer loop is tested and found free of all leaks, the system is filled with the mineral-based oil provided by Colt Inc. This can be done in

two ways. The first method is recommended: use a vacuum pump to draw a vacuum at the vent of the last row of collectors in the array and then fill the system with the fluid through the drain and fill valve in line at the expansion tank. By throttling the fill, it is possible to completely fill the entire loop with the fluid, avoiding all air entrapment. The installer must take care to use a liquid entrapment vessel between the manifold and vacuum pump for collecting the mineral oil from the last row of collectors as they fill up so that no fluid enters the vacuum pump. If the collector array is installed on a roof that is covered with asphalt shingling or on a flat roof that is coated with asphalt and gravel, additional care should be taken to avoid spilling any of the mineral oil on the roof itself. A more detailed explanation of this last point is provided in Section 5.3.

If the contractor decides not to use a vacuum pump, a second method may be used. The heat transfer loop can be filled from the fill and drain valve at the expansion tank location with the use of an auxiliary circulator pump. Colt Inc. provides this pump on a per day rental basis. It is necessary to pump the oil up through the system until it begins to exit at each vent valve located at the end of each collector row. Again, care should be taken to avoid spilling any oil on the roof. The removal of all entrapped air cannot be guaranteed with this method of system fill, and it is therefore not the

preferred alternative. During the system operation, this entrapped air is purged, however, at the air purger and flow vent installed on the expansion tank (if the system is so equipped).

After system filling has been completed the installer should operate the system through the by-pass filter, installed on the suction side of the pump, to thoroughly cleanse the circulating fluid of all contaminants. After operating in this manner for four or more hours, the installer can then close the by-pass valves and remove and clean the filter.

3.7 Domestic Hot Water Installation

After the heat transfer loop portion is completed, the installer may proceed with the domestic hot water system installation.

3.7.1 Connecting Domestic Water to Thermal Storage

In Section 3.6.4, the installer is given specific instruction on how to install the plumbing from the secondary heat exchanger (the domestic water heat exchanger), to the exterior portion of the thermal storage vessel or the thermal storage vessel enclosure. The installer must bring the main line from the city water to the thermal storage vessel area and install this line to the lower 3/4" line coming from the secondary heat exchanger. It is recommended that a standard anti-syphon valve be installed in this line prior to connecting the line to

the heat exchanger. The installer should leave sufficient room between the anti-syphon valve and the connection to the heat exchanger to install a tee, from which will run a line to the globe valve which is a part of the tank-fill plumbing line referred to in Section 3.6.5. The installer may now connect 3/4" copper tubing to the second line coming from the domestic water heat exchanger and run this 3/4" line in to the water heater.

3.7.2 Installing Auxiliary Hot Water Storage Tank

A standard gas or electric water heater may be used as the auxiliary hot water storage tank. It should be sized to handle estimated usage. Colt Inc. recommends the use of an electric water heater with a minimum size of 60 gallons. The contractor completes the domestic hot water installation by connecting the 3/4" copper tubing between the exiting line of the domestic water heat exchanger and the cold water inlet of the water heater. The hot water outlet from the water storage tank is connected to the existing hot water lines in the building.

A recirculation pump may be installed as an optional system component. The addition of this pump to the domestic hot water circuit will assure that domestic hot water will be continuously recirculated from the water heater through the heat exchanger located in the thermal storage vessel. This will prevent the activation of the auxiliary heating unit

within the water tank during extended periods of little or no domestic hot water usage.

3.7.3 Connecting Electricity to Auxiliary Hot Water

The contractor should arrange to have an electrician connect 220-voltage AC power to the water heater, according to industrial electrical standards. If the water heater is a gas-fired model, the installer should connect it to the gas supply according to local code requirements.

3.7.4 Checking for Hot Water Leaks

After the entire domestic hot water line is connected properly, it is possible to check for leaks by using the freon pressurization system coupled with a freon leak detector. Colt Inc. recommends that to conduct the test properly, the line should be pressurized to between 50 and 75 psi. The contractor may choose a second method in which he pressurizes the system with air and checks for leaks by applying a detergent solution at each soldered and mechanical connection. A third method, of course, would be to run city water slowly through the system while watching each soldered and mechanical connection for visible signs of leaks. All tests should be completed before proceeding to system filling.

3.8 Heating System Installation

The space heat system includes a liquid-to-air heat exchanger.

and an auxiliary heat source as a second source of heat. Both are installed into the ductwork in a conventional forced-air heating system. A general plumbing schematic is illustrated in Figure 3.8-A.

3.8.1 Installing Heat Exchanger Coils

Colt Inc. supplies a liquid-to-air heat exchanger that has been sized specifically for this installation. Figure 3.8-B illustrates the way in which this heat exchanger is installed within the forced-air ductwork. The exchanger is provided with flanges that have mounting holes already bored. The two sections of the forced-air ductwork adjoining both sides of the heat exchanger coil unit should be provided with a flange depth that aligns with the flanges on the heat exchanger.

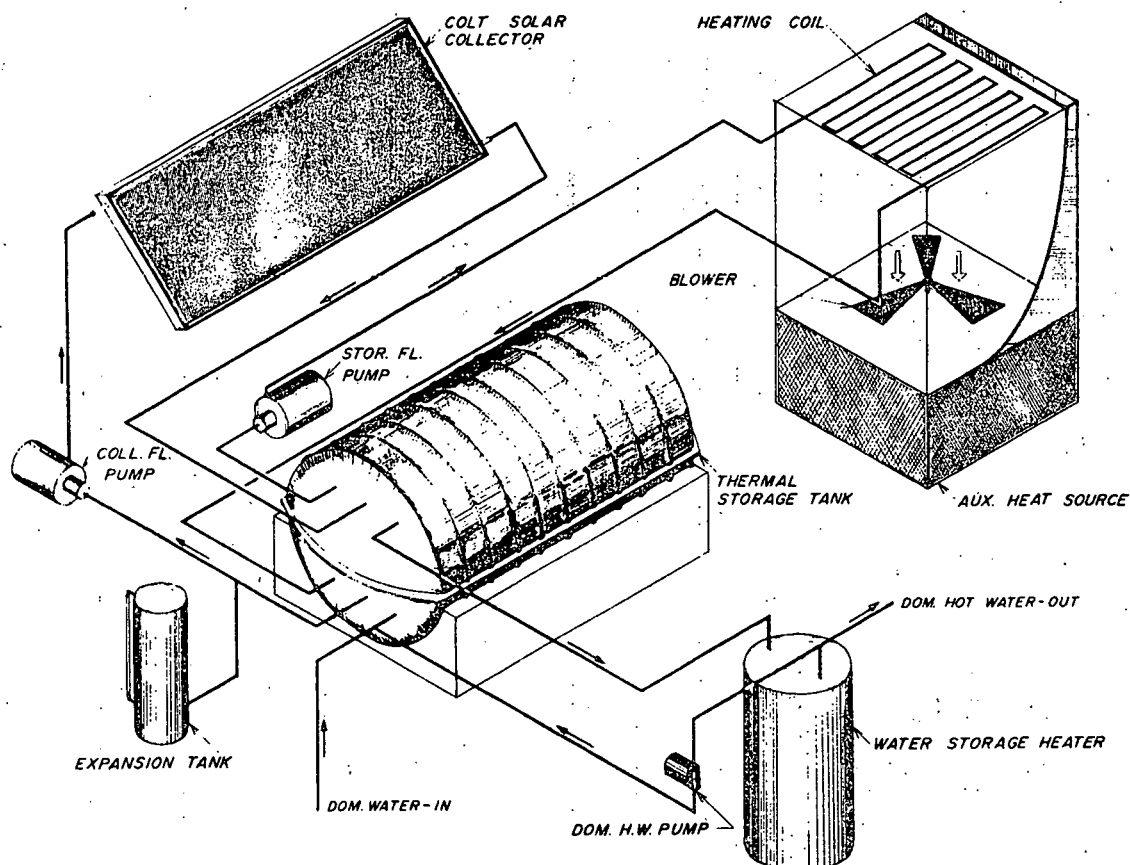

FIG. 3.8-A PLUMBING SCHEMATIC

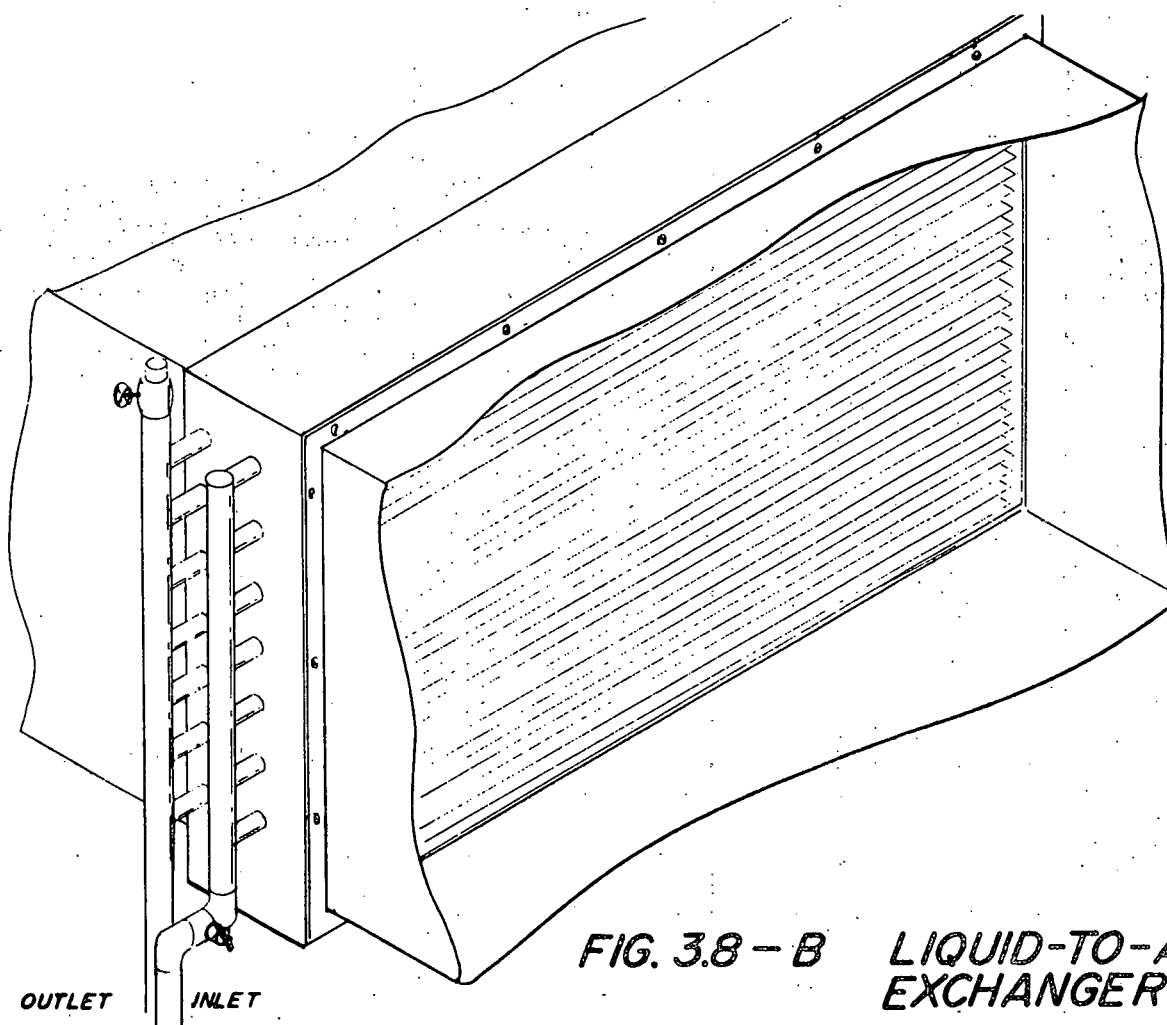

FIG. 3.8 - B LIQUID-TO-AIR HEAT EXCHANGER INSTALL.

Holes are bored into the flanges of the ductwork adjacent to both sides of the exchanger. Existing holes in the heat exchanger are used as a guide for boring. Standard sheet metal screws are used to connect the ductwork to each side of the heat exchanger coil unit. The assembly is now ready to be installed into the ductwork in much the same way that a normal forced-air furnace would be installed. If necessary, the blower and motor used in this installation can either be purchased separately by the contractor or obtained from Colt Inc. as part of the system component package. The blower and motor should be installed in the forced-air ductwork between the filtering system in the cold-air return duct and the heat

exchanger coil assembly. The heat exchanger may be installed in either a vertical or horizontal mode, whichever lends itself more conveniently to the space available for this purpose, but must be installed upstream of the auxiliary heating device.

3.8.2 Installing Coil Plumbing

Colt Inc. specifies the size of copper tubing needed to meet the space heat requirements of this installation. The appropriate copper tubing stubs are supplied as part of the thermal storage vessel unless the contractor purchased an unassembled unit. In this case, Section 3.6.4 clarifies how the copper tubing for the space heat application is stubbed in place. It is necessary to connect copper tubing from the thermal storage vessel to the liquid-to-air heat exchanger located in the forced-air ductwork. More specifically, the copper tubing connects the exiting water line which leads from the upper part of the thermal storage vessel through the water system pump to the inlet of the liquid-to-air heat exchanger coil. This allows water of maximum temperature to run through this heat exchanger. A swing check valve is to be installed just outside the thermal storage vessel in the line that connects the water system tubing exiting from the upper part of the thermal storage vessel to the water system pump. The pump is to be hooked up in the same way that the pump for the collector fluid line is connected, that is, with the use of unions to facilitate removal and servicing

when required. Next, the installer is to attach a line connecting the pump to the inlet of the heat exchanger coil. The installer should provide a tee with a vent valve in the high point of the line exiting the heat exchanger coil so that air can be purged from the system on start-up and testing. This line is to run from the heat exchanger coil back to the storage water inlet located in the lower part of the thermal storage vessel. This completes the solar heating section installation.

3.8.3 Checking Heating System for Leaks

Because the heating system is not a closed loop, but open to the inside portion of the thermal storage vessel, it is not possible to pressurize the entire loop. However, the installer can pressure test the lines by placing end caps on the main and return lines outside the thermal storage vessel before running the lines into the vessel. With these end caps in place, he may remove the system pump at the unions and insert a short section of copper tubing with a tee connected to a vent valve. He then can pressurize the system with either air or freon and perform leak tests as described in Section 3.6.9 of this manual. After completing the test, he must re-install the pump, remove the end caps that are soldered in place on the main and return lines, just outside the thermal storage vessel, and then finish installing the heat-system plumbing within the vessel itself. He should then be careful to watch for leaks, in line where the end caps were soldered, when the

heating system is started up.

3.8.4 Installing Auxiliary Heating Systems

The auxiliary heat source may be either a standard gas furnace, a central electric strip heater, individual room duct strip heaters, or a heat pump.

Colt Inc. specifies the total estimated BTU requirement and the corresponding total required kilowatt output. The contractor, however, is responsible for supervising the proper installation of the auxiliary heat source according to the standard industrial practice in the geographic area.

3.9 Insulate All Piping

To facilitate most efficient operation of the heating system, Colt Inc. will, if necessary, specify the R-value of the insulation that is to be used around all exposed piping. The contractor may choose the type insulation to be used and is responsible for supervising its correct installation. He should note that all exterior piping must be insulated and then coated with a weather-proof membrane. Colt Inc. suggests specific brands and suppliers to provide the best type of insulation for each purpose within the heating system.

The following piping must be insulated: (1) the entire heat collection/transfer loop; (2) the domestic water piping between

the thermal storage vessel and the hot water storage tank; and (3) the space heat supply and return lines running between the thermal storage vessel and the heat coil within the ductwork.

3.10 Controls Installation

The control system design includes the following: (1) a differential control coordinating the heat collection/transfer fluid pump with the amount of available insolation, and (2) two separate motor controllers coordinating the solar and auxiliary source heating operation. A third differential controller is necessary, if a domestic hot water circulating pump is used. An illustration is provided to clarify the installation of these control designs. Figure 3.10-A, the system schematic, shows

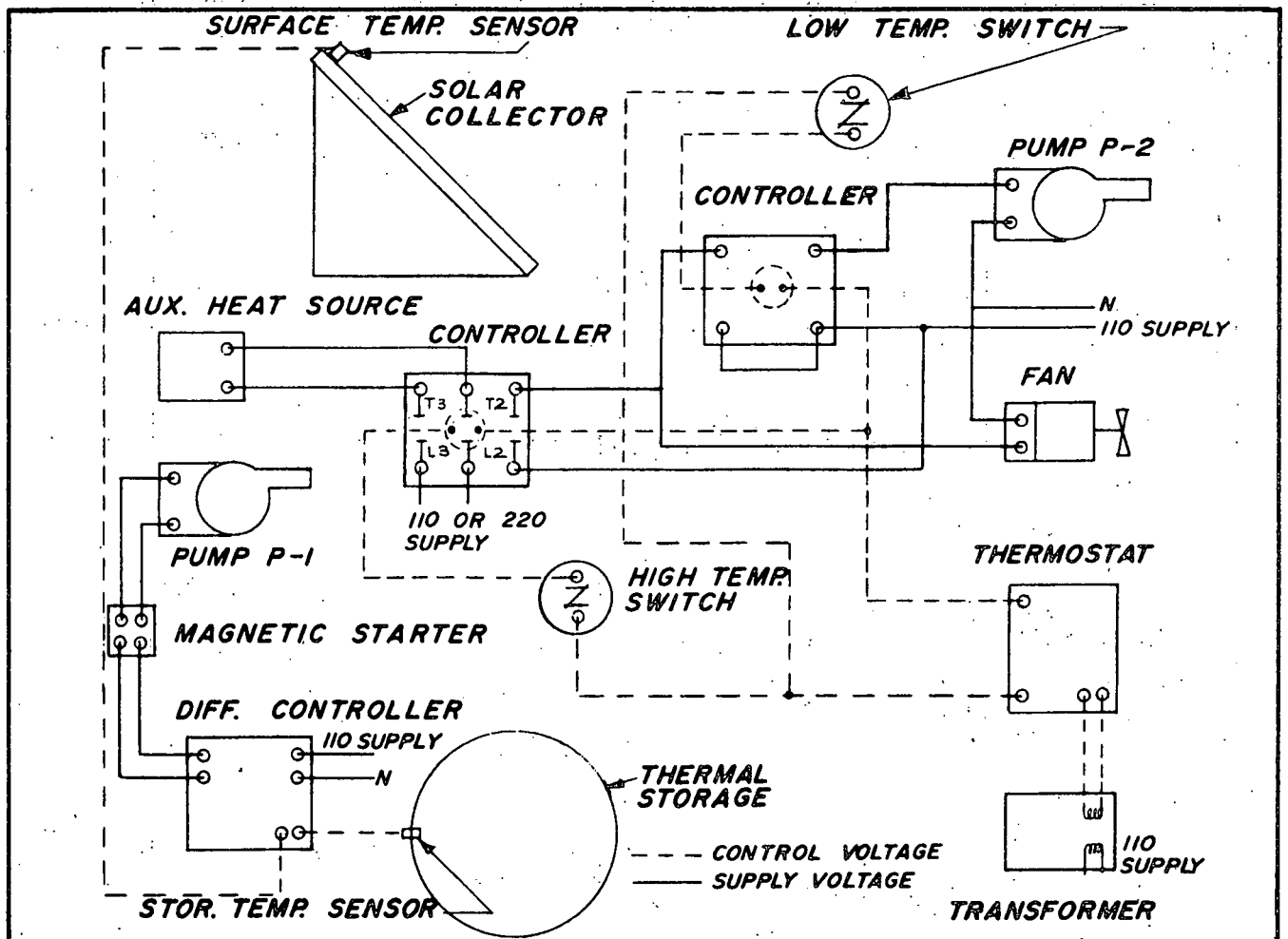

FIG. 3.10 - A WIRING DIAGRAM

the placement of the differential controller, the sensors, temperature switches, the standard thermostat and the two motor controllers within the control circuit. Figure 3.10-B is an alternate system schematic which illustrates a two-stage thermostat rather than the high temperature switch.

3.10.1 Installing Differential Controller

A specific differential controller with installation instructions and a schematic is supplied as part of the system component package. Basically, its function is to monitor the pumping activity within the heat transfer loop. (See Section 4.1 for a more detailed explanation.) It can be installed anywhere near the collector fluid pump.

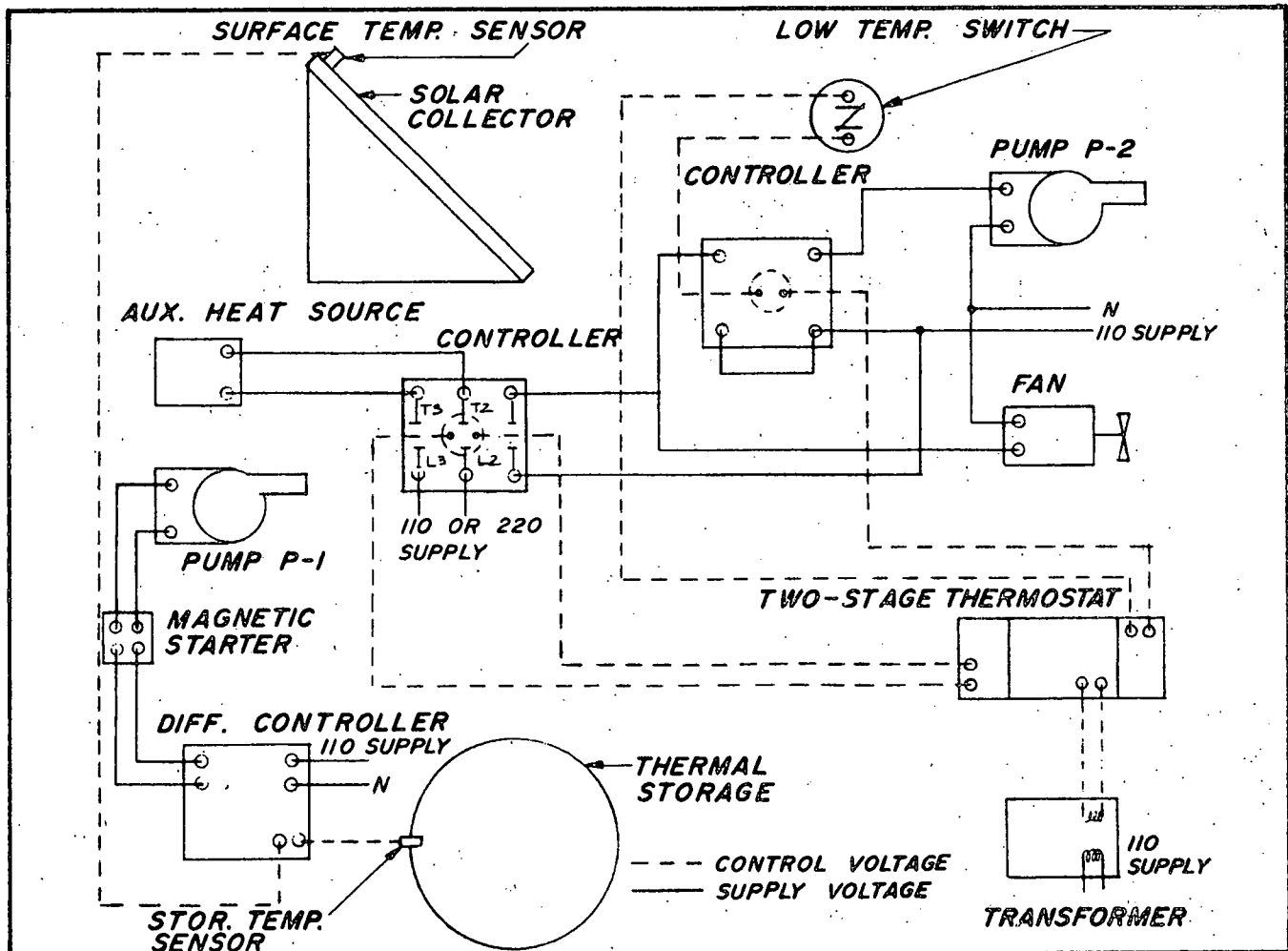

FIG. 3.10-B ALTERNATE WIRING DIAGRAM

Two sensors activate the differential control. One of these sensors is installed as part of the thermal storage vessel installation. (Review Section 3.6.6.) The other is a small sensor which is installed by Colt on the absorber surface of one of the solar panels. Its purpose is to measure solar collector surface temperature. Colt Inc. recommends that 18-gauge, two-conductor stranded wire in conduits be used to attach the sensors to the differential controllers.

If a domestic hot water circulating pump is used in this installation, Colt will supply another temperature sensor to be installed within the domestic hot water storage tank. Figure 3.10-C illustrates this installation. In this case, the

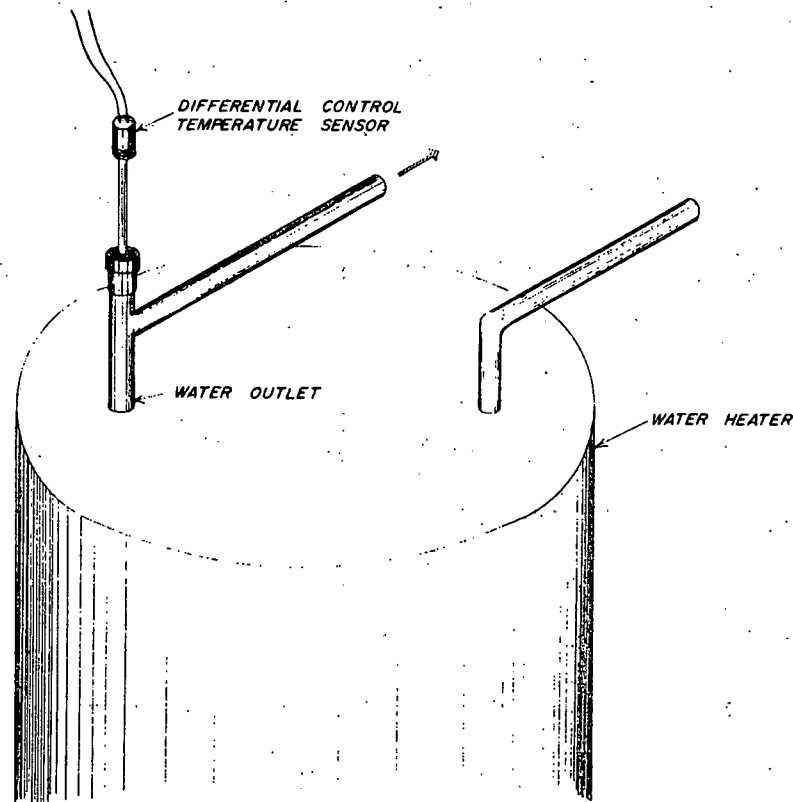

FIG. 3.10 - C RECIRCULATION PUMP SENSOR INSTALLATION

temperature sensor which is included as part of the thermal storage vessel installation comes with two sets of leads.

This second set of leads is to be attached to the appropriate leads within the differential controller. Specific installation instructions, including a schematic, are provided as part of the component package.

3.10.2 Installing Temperature Thermostat

The temperature thermostat is a standard room thermostat. It should be installed in a convenient place inside the building and is connected as shown in the schematic, Figure 3.10-A. The thermostat has a dual purpose: (1) to control the activity of the auxiliary heat source, and (2) to control the pumping activity within the solar space heating system. If a two-stage thermostat is used, the installer should refer to Figure 3.10-B for a diagram of proper wiring. He should note that the high temperature switch is eliminated. It is important that the auxiliary heat source controller is connected to the second stage within the room thermostat. For new buildings, all wiring to and from the thermostat should be run during the prewiring stage of construction.

3.10.3 Installing Motor Controllers

Colt Inc. supplies two motor controllers as part of the system component package. These controllers are sized for the

voltage and amperage requirements of their respective control activity. (See schematic, Figure 3.10-A or 3.10-B.) The motor controllers can be installed within the utility or maintenance section of the building and should be wired through conduit using a method standard to the electrical codes in that geographic area.

One of the controllers will activate the water pump within the solar space heat portion of the system. It is controlled by the room thermostat and by the low temperature switch previously installed. (Review section 3.6.6.) All control wiring is low-voltage, 24-volt wiring. The motor controller is equipped with a relay activated by a low-voltage power source. The relay contacts are either 110- or 220-volts, sized for the water pump used in the system.

The other motor controller is controlled by the same room thermostat and by the high temperature switch previously installed, or by the second stage within the two-stage thermostat. (Review Section 3.6.6.) The controller is also equipped with a relay activated by a 24-volt source. The relay has 220-volt contacts which control the activity of an electrically supplied auxiliary source heat system. However, if the auxiliary source is a standard gas furnace, or a gas heat pump, a low-voltage relay will be used to send a 24-volt signal to the pilot and burner assembly within the gas furnace.

3.11 Testing System

Testing is required to make sure that all controls within the system are functioning properly. The tests covered in this section are meant as a guide only. If the electrical or plumbing sub-contractor prefers other reliable tests, he is encouraged to use them.

3.11.1 Testing Electrical Controls

The schematic, Figure 3.10-A, shows that the electrical control circuit contains the high temperature switch, the room thermostat and one motor controller. The high temperature switch is a normally closed switch which opens when the temperature rises to 105°F. Before it is installed, this switch can be tested with an ohm meter to make sure that it is closed at ambient air temperatures below 105°F. The contractor can then place the switch in water heated somewhat above 105°F. If the switch is operating properly, it should open immediately upon being submerged. Assuming that the ambient air within the thermal storage vessel is below 105°F, the auxiliary heat electric system can also be tested by adjusting the room thermostat so that the internal contacts close, at which point both the fan and the auxiliary heat source should be activated.

3.11.2 Testing Flow Controls

As indicated by the schematic, the flow control part of the system contains the low temperature switch, the room thermostat and the motor controller which activates the system

water pump. The low temperature switch is a normally-open switch which closes when the temperature rises to 90°F. This switch can be tested with a standard ohm meter to make sure that it is open at ambient air temperatures below 90°F. The contractor can then place the switch in water heated somewhat above 90°F. If the switch is operating properly, it should close immediately upon being submerged. To test the flow-control electric system, it is necessary to remove the low temperature switch from its position in the thermal storage vessel and immerse it in water known to be above 90°F. Now the thermostat should be adjusted so that the internal heat contacts close, at which point, both the fluid pump and the air blower should be activated. To make sure that the centrifugal pump has water running through it during the test, it is important that a hose carrying city water be attached to the fill valve on the suction side of the water pump.

After the tests have been satisfactorily completed, both the high and low temperature switches can be re-installed into the thermal storage vessel.

3.11.3 Testing Safety Devices

A safety device that should be tested is the pressure relief valve installed at the expansion tank in the heat-transfer fluid loop. Colt supplies this relief valve factory pre-set at a safe maximum operating pressure. By slowly pressurizing

the system at the expansion tank to the pre-set pressure, if the valve is operating correctly, it should automatically relieve the pressure buildup when the pre-set pressure is reached. This test should be conducted before filling the heat collection/transfer fluid loop with mineral oil.

3.12 Filling the Thermal Storage Vessel

The thermal storage vessel is filled by opening the globe valve from the domestic water supply. If the contractor has decided not to install the float switch, he should provide a dip stick to measure accurately the height of the water within the vessel. The stick is marked at the recommended height for system operation which will maintain the water level to within one foot of the inside top surface of the vessel. The contractor should avoid exceeding the dip stick mark when filling the vessel with water. If a float switch has been installed, he should fill the system until the indicator light goes off.

3.13 Balancing Performance

The three positions on the differential controller switch are "off," "on" and "automatic." In the "automatic" position, the system is controlled by the two temperature sensors: one on the collector surface, the other inside the thermal storage vessel. However, while balancing the system, the "on" position must be used to gain manual control of the heat-transfer fluid

pump. The "off" position merely turns the system off.

The system should be balanced during daylight hours when an appreciable amount of insolation is being received. The installer places a thermometer into each thermowell installed at the end of each collector return manifold. While continuously monitoring the temperature readings, the contractor throttles the ball valves in the supply manifold until all thermometers indicate the same temperatures. This balancing should be done long enough to make sure that the system is stabilized.

4.0 System Operation

Up to this point, the manual has covered the installation procedure for the Colt solar heating system. From this point on, the manual deals with system operating procedures established by Colt Inc. to assure the correct and most efficient operation of the system.

4.1 Description of System

A solar heating system is a two-part system consisting of energy collection and energy distribution.

Energy collected within the system is called "free energy" because it comes from an inexhaustible supply; that is, the sun. It is a non-polluting form of energy collection and is

indeed free after all original costs have been recaptured.

The energy collection apparatus consists of an array of solar panels, the fluid transport loop, the fluid pump and the differential controller which activates the pump. The controller activates the pump, turning it on when a pre-set temperature differential of 20°F is reached. This differential is defined as the difference in temperature between the surface of the solar collectors and the water within the thermal storage vessel.

When the 20°F temperature differential is reached at the beginning of the day, the differential controller turns on the fluid pump. At this differential and greater, the pump runs at full speed achieving maximum heat-collection capability.

As the fluid passes through each solar panel, it absorbs heat directly from the collector surface and transports the heat to the heat exchanger inside the thermal storage vessel. As the fluid passes through the exchanger, it releases the heat to the surrounding water inside the storage vessel. The fluid then passes out of the heat exchanger to return to the solar panels for reheating, and the cycle is completed. After start-up, this cycle is repeated continuously throughout the day at maximum heat-collection capability as long as the temperature differential is 30°F or greater. Toward sunset, as the collector surface begins to cool and the differential

decreases to 3°F and below, the controller turns the pump off. This is a very important part of the system control because it is undesirable for the pump to be operating when the collector surface temperature is equal to or below that of the water temperature contained within the thermal storage vessel. If the pump is turned on when the temperature of the solar collector surface is less than that of the water in the storage vessel, the solar collector will act as a liquid-to-air heat exchanger, dissipating heat from the thermal storage vessel into the atmosphere. This is obviously an undesirable condition and can be avoided by operating the differential controller correctly.

The energy distribution apparatus includes the water pump and the liquid-to-air heat exchanger which is installed in the forced-air ductwork. Heat is distributed when ambient air within the building is low enough to close the heat switch contact inside the room thermostat. The temperature of the water inside the vessel determines whether the solar heat, auxiliary heat, or both systems will be activated to meet the heat requirements of the building.

If only the solar heat system is activated, heat is distributed by hot water transported from the thermal storage vessel to the liquid-to-air heat exchanger inside the forced-air ductwork. The hot water gives up heat to the air being blown across the coils. The storage vessel is sized to meet most

thermal energy requirements, even during periods when there is no insolation. Depending upon the number of people using the system and their individual heat requirements, the thermal storage vessel can possibly meet space and water heating demands for several days during periods of inclement weather. If the heat contained within the storage vessel is insufficient to meet the space heat requirements, the auxiliary heat system will activate automatically. This is regulated by the high and low temperature switches installed within the thermal storage vessel. When the water within this vessel is above 105°F, the solar energy system can, without any assistance, meet all normal space heat requirements. When the water is below 90°F, the system cannot meet any of the space heat requirements (the low temperature switch turns the system water pump off). When the temperature of the water in the storage vessel is between 90°F-105°F, the solar heat system can meet the space heat requirements. However, it may do so at a slower rate than the building occupants are willing to tolerate. For this reason, the auxiliary heat system is activated at a 105°F water temperature and below.

In summary, (1) when the water within the thermal storage vessel is above 105°F, all space heat requirements are met by the solar heat system; (2) when the temperature of the water is below 90°F, all space-heat requirements are met by the auxiliary heat system and (3) when the temperature of the

water is between 90°F and 105°F, both systems operate to meet space heat requirements.

If the contractor chooses a two-stage thermostat as part of the system control, then the high temperature switch operating criterium is not applicable. Instead, the auxiliary heat source will be activated when room temperature drops to two degrees below that temperature set on the room thermostat. The solar control portion as described above will still be applicable.

4.2 Nominal System Operating Parameters

Colt Inc. includes as part of its data package the nominal operating parameters that should be maintained to provide the most efficient heat collection and distribution. These parameters include a heat collection/transfer fluid flow rate of approximately .7 gallons per minute for each collector installed within the array; a storage water flow rate of five to 10 gallons per minute; and an expected temperature rise between 10 and 12 degrees per pass through each collector. The contractor should make sure that the blower and motor combination is correctly sized so that it will provide the desired air flow rate when operating inside the duct system. Colt Inc. has thoroughly studied the space-heat requirements for this building and is supplying pumps that meet required flow rates for both the heat-transfer fluid and water systems.

This information on flow rates is provided on the specification sheet within the data package. If the contractor chooses to monitor the two fluid flow rates, he can do so by installing visual flow meters in each of the two lines.

4.3 Effect of Variations on Performance

System performance will be adversely affected if the flow rates vary appreciably from specifications. Within the energy collection and transport loop, a variation in the fluid flow rate will cause a decrease in the rate of thermal energy input into the storage vessel. A variation in the water flow rate causes less than efficient liquid-to-air heat transfer.

5.0 Maintenance

The Colt solar heating system is a sophisticated heating system and, in some ways, can be considered a commercial heat plant. It is somewhat more complex than the standard gas or electrically powered furnace found extensively in today's housing industry. For this reason, the solar heating system may require general maintenance unfamiliar to the average homeowner. The following sections outline various maintenance areas that one can expect to encounter.

5.1 Routine and Preventive Maintenance

Routine and preventive maintenance should be performed on a regular schedule for increased overall system longevity.

The collector surfaces should be washed thoroughly when dirty; approximately four times a year. This maintenance should be done only when the collector surface is cool, during the early morning hours. It should not be performed at any time during considerable insolation since the thermal shock to the glass surfaces may be sufficient to cause breakage.

Both pump motors and the blower motor should be lubricated using the correct weight motor oil at intervals specified within the instructions supplied with each of these components.

The water level within the thermal storage vessel should be checked every three months and water should be added if it has dropped below the recommended level. Also, this water should be tested for alkalinity periodically, and, if necessary, neutralized to help prevent mineral buildup within the coils of the liquid-to-air heat exchanger.

The mineral oil within the heat collection/transfer loop should be checked every twelve months for signs of sludging or general deterioration by running a small amount of oil from a vent valve in the solar panel array. Care should be exercised to prevent spilling oil on to the building roof. This oil has an indefinite closed-loop operation lifespan if proper maintenance is observed. However, if it comes in constant contact with an air interface, it will show severe

discoloration and sludging.

The water in the water storage heater should be flushed periodically to minimize rust and mineral buildup.

The air filter inside the ductwork should be changed every six months or, if needed, sooner, depending upon geographic location.

5.2 Trouble Shooting

The Colt solar system is primarily made up of two sub-systems: one, mechanical; the other, electrical. If problems occur in either of the two sub-systems, the following is a brief trouble-shooting guide that should be followed while trying to locate the source of the failure.

A problem occurring within the mechanical sub-system usually manifests itself by a variation in fluid flow rate or a decrease in heat output from the thermal storage vessel. The maintenance technician should begin by looking for leaks within the system. If he does not find any leaks, he should check the pump to see if it has lost its prime, which will cause severe damage to the pump impeller. In this case, the pump will not be operating. However, if a small amount of air is entrapped within the system, the pump will continue to operate, but at less than an optimum performance level. In this

case, the maintenance technician should bleed off some of the oil from the pump housing to check its clarity. If the oil from the pump is foamy, it will indicate cavitation because of excessive air entrainment.

If other components, such as valves, fail to function properly, the system could be contaminated with dirt, steel wool, solder chips or other foreign particles that might not have been removed during filtration prior to operating the system. The specific component may have to be removed for cleaning or, possibly, replacing. System contamination may also come from a hot oil/air interface that has lasted long enough to cause sludging of the mineral oil, which is discussed previously in this section. The sludging or excessive discoloration will be immediately apparent.

In this case, it is necessary to re-install the system filter to trap any large particles and then to pump the oil out of the system. When this is completed, the system may be filled with new oil. (Review Section 3.6.9.) Before actual start-up of the system containing the new oil, the filtering process explained above should once again be used.

Electrical malfunctions could be caused by a failure within the primary power circuit which includes the 110- and 220-volt main circuits, the control panel and connections to the

controllers and other system components. If there is a failure in the heat transfer fluid line not due to the pump itself, then the maintenance technician should look for an electrical failure by inspecting the wiring from the pump through the differential controller to the two thermal sensors: one on the roof, the other in the thermal storage vessel. The technician should test both of these sensors with a standard ohm meter to assure that there is no line break. He should then make sure that the differential controller is in good operating condition and that the triac and other electronic components within the controller have not been burned or damaged in some other way. He should make sure that all relays are operating correctly.

If there is a failure in the auxiliary heat source apparatus, the technician should first test the two temperature switches installed within the thermal storage vessel; that is, the low temperature and high temperature switches. He should make sure that there are no line breaks. He should also make sure that the room thermostat is operating properly and then check the lines leading to the two controllers that operate the pump and the auxiliary heat source. Finally, he should test the specific component, that is, the water pump motor and the auxiliary heat source.

5.3 Unscheduled Maintenance

Unscheduled maintenance is major maintenance required as the

result of a failure in a system component, of plumbing leaks, or of a malfunctioning electric controller. Such maintenance generally requires the services of an electrician or plumbing contractor.

Two types of unscheduled maintenance include: (1) problems occurring within the thermal storage vessel, and (2) problems resulting from failure of component parts, in particular, the two fluid pumps.

If it is necessary to gain access to the interior of the thermal storage vessel, the repairman should first pump as much water out of the vessel as necessary to gain this access. It is very important that the interior of the vessel is properly ventilated before the repairman enters it. If the vessel has to be completely drained to service an interior component, the repairman should clean out all accumulated sludge at the bottom of the vessel before refilling it.

In the case of pump failure, the pump can be easily removed from its position within the fluid loop at the union junctions. After the pump is serviced and while it is being reinstalled into the fluid loop, the repairman should make sure no air gets into the loop. This is accomplished by first reconnecting the fluid line at the union on the suction side of the pump; then, by pulling slightly out of alignment the tubing

connected to the discharge side of the pump, it is possible to fill the discharge tube and pump with replacement heat-transfer oil by using a funnel. Finally, the discharge side of the pump can be connected to the fluid loop by joining the upper union halves. Should a small amount of air enter the system during this process, it is purged at the vent valve.

Two precautions must be taken to repair leaks that occur, either on the roof or inside the building: (1) remove any oil that has leaked onto the building roof; (2) drain the oil from the immediate work area in the heat transfer loop where soldering is to be done.

Oil on the roof should be cleaned up as thoroughly and quickly as possible by using a common detergent dissolved in water. If mineral oil is allowed to remain on the roof for an extended period of time, it can soften asphalt shingles. The repairman should be especially careful while doing any type of repairing or venting of the collector manifold.

When it is necessary to resolder a fitting or to exchange fittings within the heat transfer loop, the repairman should first drain the oil from the immediate work area, if possible. He then should cut out the defective part with either a tubing cutter or a hacksaw. Before installing a new component with couplings, he should try to dry out as much mineral oil

as possible from the inside of the adjacent tubing. If proper precautions are taken, there should be no problem soldering the new component in place. After the repair or replacement is completed, it is necessary to use a vacuum to facilitate thoroughly filling the system and removing all entrapped air.

If a minor leak occurs at a fitting that is soldered in place, it is not necessary to drain the oil in the area of the leak in order to make a solder-type patch. Because the oil is in an air-free environment, it cannot support combustion, even while the repairman is soldering the exterior of the pipe and fitting. He should, however, thoroughly clean the area before soldering to assure good adhesion. Note that, when normal soldering practices are followed, even residual mineral oil in the fluid lines will not present a combustion hazard.

5.4 Safe Installation & Maintenance Procedures

The objective of this section is to familiarize the maintenance technician with information that will help him perform his job in a safe manner. First of all, extreme care should be taken when using a soldering torch to repair the heat collection/transfer fluid line. The fluid flowing within this line is not water, but a mineral oil with a specific flash point. However, the line can be repaired in a safe way, as indicated in Section 5.3, which provides instructions for repairing leaks.

Another point on maintenance safety is: the pressure relief valve in the collector fluid line should be checked periodically to make sure it is functioning properly. This can be done by slowly pressurizing the system until the specific pre-set pressure is reached. At this point, the valve should open, relieving the excess air pressure from the top of the expansion tank.

A third point on maintenance safety is a warning about cleaning the collector glass surface during periods of considerable insolation. All maintenance on the glass surfaces of the collectors should be done only during early morning hours when it is cool in order to avoid breakage resulting from thermal shock to the glass surface.