

ENERGY

CONSERVATION

120
9-14-78

LB. 519

COO-4211-2

GRID-CONNECTED INTEGRATED COMMUNITY ENERGY SYSTEM

Preliminary Report, Phase II, August 9–November 8, 1977

Work Performed Under Contract No. EC-77-C-02-4211

Clark University
Worcester, Massachusetts

MASTER



U. S. DEPARTMENT OF ENERGY

Division of Buildings and Community Systems

DISTRIBUTION OF THIS DOCUMENT IS UNLIMITED.

DISCLAIMER

This report was prepared as an account of work sponsored by an agency of the United States Government. Neither the United States Government nor any agency Thereof, nor any of their employees, makes any warranty, express or implied, or assumes any legal liability or responsibility for the accuracy, completeness, or usefulness of any information, apparatus, product, or process disclosed, or represents that its use would not infringe privately owned rights. Reference herein to any specific commercial product, process, or service by trade name, trademark, manufacturer, or otherwise does not necessarily constitute or imply its endorsement, recommendation, or favoring by the United States Government or any agency thereof. The views and opinions of authors expressed herein do not necessarily state or reflect those of the United States Government or any agency thereof.

DISCLAIMER

Portions of this document may be illegible in electronic image products. Images are produced from the best available original document.

NOTICE

This report was prepared as an account of work sponsored by the United States Government. Neither the United States nor the United States Department of Energy, nor any of their employees, nor any of their contractors, subcontractors, or their employees, makes any warranty, express or implied, or assumes any legal liability or responsibility for the accuracy, completeness or usefulness of any information, apparatus, product or process disclosed, or represents that its use would not infringe privately owned rights.

This report has been printed directly from copy supplied by the originating organization. Although the copy supplied may not in part or whole meet the standards for acceptable reproducible copy, it has been used for reproduction to expedite distribution and availability of the information being reported.

Available from the National Technical Information Service, U. S. Department of Commerce, Springfield, Virginia 22161.

Price: Paper Copy \$7.25
Microfiche \$3.00

PREFACE

The reader should note that the draft contract between Clark and the Massachusetts Electric Company presented in Appendix 2B has been superseded by a new draft which, however, arrived too late to be included in this report. Because of our uncertainty about the nature of the final agreement, the economic analysis presented in this report is based on the understandings in effect at the end of Phase I. While the general conclusions we present are still correct, the reader should refer to the Phase II Final Report for all details.

GRID-CONNECTED INTEGRATED
COMMUNITY ENERGY SYSTEM

PRELIMINARY REPORT

PHASE II

FOR PERIOD

AUGUST 9, 1977, TO NOVEMBER 8, 1977

CLARK UNIVERSITY
950 MAIN STREET
WORCESTER, MASSACHUSETTS 01610

NOTICE
This report was prepared as an account of work sponsored by the United States Government. Neither the United States nor the United States Department of Energy, nor any of their employees, nor any of their contractors, subcontractors, or their employees, makes any warranty, express or implied, or assumes any legal liability or responsibility for the accuracy, completeness or usefulness of any information, apparatus, product or process disclosed, or represents that its use would not infringe privately owned rights.

PREPARED FOR
THE U. S. DEPARTMENT OF ENERGY
UNDER CONTRACT NO. EC-77-C-02-4211.A001

PREPARED BY
CLARK UNIVERSITY
THERMO ELECTRON CORP.
FITZMEYER AND TOCCI, INC.
BOZENHARD COMPANY
SHEPHERD ENGINEERING
NEW ENGLAND ELECTRIC SYSTEM
L. G. COPLEY ASSOCIATES

MASTER

DISTRIBUTION OF THIS DOCUMENT IS UNLIMITED *EB*

CONTENTS

1.	Introduction.....	1
2.	Institutional Documentation.....	4
	2.0 Introduction.....	4
	2.1 Corporate Power.....	4
	2.2 Interchange Terms.....	4
	2.3 Financing.....	5
	2.4 Environmental Impact.....	7
3.	Preliminary Design Analysis.....	9
	3.0 Introduction.....	9
	3.1 Energy Load Profiles.....	9
	3.2 Design Options and Final Choice of Engine.....	11
	3.3 Update of Conceptual Design.....	14
4.	Cost Analysis.....	17
	4.0 Introduction.....	17
	4.1 Capital Costs.....	17
	4.2 Fuel and Maintenance Costs.....	19
	4.3 Comparison with the Conventional System.....	20
	4.4 Evaluation of the Investment.....	27
Appendices		
1A	Letter from Lawrence Landry, Vice President of Business and Finance and Treasurer.....	28
2A	Letters for Institutional Documentation.....	32
2B	Present Retail Electricity Rate and Standby Terms.....	38
2C	Environmental Evaluation Report.....	51
3A	Engine Operating Experience and Guarantees.....	103
3B	Plant Descriptions.....	106
3C	Performance of the Candidate Systems.....	111
3D	Heavy Fuel Treatment System.....	121
4A	Detailed Capital Cost Analysis.....	126
4B	Operation and Maintenance Costs.....	131

TABLES

2.4-1	Estimated Air Pollution Impact--Present System and Proposed Grid-Connected ICES.....	8
3.3-1	Performance Characteristics of Three Diesel Engines.....	15
3.3-2	Properties of Fuel Treatment System.....	15
4.1-1	Capital Cost Summary.....	18
4.2-1	Fuel Cost and Heat Credit.....	19
4.2-2	Maintenance Costs.....	20
4.3-1	Base Case Assumptions.....	21
4.3-2	Electricity and Thermal Outputs.....	22
4.3-3	Financial Analysis of the System.....	23
4.3-4	Key Parameters for Sensitivity Analysis.....	25
2C-EIA-1	Noise Levels at Clark University.....	60
2C-EIA-2	Baseline Sound Data.....	62
2C-EIA-3	Quarterly Air Pollution at Clark.....	67
2C-EIA-4	Estimated Air Pollution Impact--Present System and Proposed Grid-Connected ICES.....	77
4A-1	Capital Cost Analysis inside New Building.....	128
4A-2	Engineering Cost Analysis.....	130
4B-1	Lifetime of Major Engine Components.....	133
4B-2	Manufacturers' Recommended Limits for Vanadium and Sodium Going into Engine.....	135
4B-3	Summary of Diesel Engine Operation and Maintenance Costs.....	136
4B-4	Summary of System Operation and Maintenance Costs.....	137

FIGURES

3.1-1	Electricity Load Profile.....	10
3.1-2	Revised Thermal Load Profile.....	10
3.1-3	Energy Outputs of Sulzer Engine.....	12
3.3-1	Location of Proposed Building and Goddard Memorial, West Base; System Layout.....	16
4.3-1	Projected Base-Case Yearly Savings.....	24
4.3-2	Sensitivity of Sulzer Savings to Variation of Parameters.....	26
2C-EIA-1	Plan of the East Wing of Jonas Clark Hall.....	57
2C-EIA-2	Steam Distribution System at Clark University.....	58
2C-EIA-3	Illustration of Energy Consumption at Clark since 1970.....	63
3C-1	Schematic for Diesel Heat Balance.....	113
3C-2	Heat Balance: Sulzer, 100% Load.....	116
3C-3	Heat Balance: Sulzer, 50% Load.....	117
3C-4	Heat Balance: Superior, 100% Load.....	118
3C-5	Heat Balance: Superior, 50% Load.....	119
3C-6	Heat Balance: Fairbanks-Morse, 100% Load.....	120
3D-1	Fuel Treatment System.....	124
3D-2	Key to System Flow Diagram.....	125

1. INTRODUCTION

Clark University represents an attractive site for demonstration of cogeneration. The principal features of the site are as follows.

(1) Clark is located in New England, a region that depends on imported oil for most of its electric generation, and has some of the highest electric prices in the nation.

(2) Clark, with a 1.5 MW peak electrical demand, offers a variety of demand patterns in its 30+ major buildings.

(3) Clark already has an operating steam distribution system which serves its 12-acre campus.

(4) Clark is serviced currently by the Massachusetts Electric Company, an organization that has taken an active and creative interest in cogeneration.

In Phase I of the ERDA Demonstration ICES Program, the team from Clark University, consisting of representatives from the University, Thermo-Electron Corporation, Fitzmeyer and Tocci, and Massachusetts Electric, reported the following results:

(1) The system of choice for ICES demonstration at Clark is a diesel generator sized at about Clark's peak electric demand.

(2) In order to avoid placing additional demand on scarce light-oil sources, such a generator should burn #6 oil if at all possible.

(3) Through Massachusetts Electric's agreement to purchase excess power at about the cost of displaced fuel, the system can run at nearly full capacity the year round, sell 40% of its output to the utility, and receive backup as needed from the utility.

(4) Under a variety of possible financing plans, and reasonable projections of fuel costs, the system will deliver for Clark an internal rate of return of 15-20%.

(5) There appear to be no institutional or environmental problems that would prevent operation of the system as planned.

In this report we provide an update on a number of issues that were incompletely resolved in the Phase I report.

In Section 2 we provide additional documentation on institutional

issues involved in the proposed demonstration at Clark, particularly as follows.

(1) According to the best information available from the State Attorney General's Office, there will be no problem with Clark's sale of electricity to the utility.

(2) We have now a draft agreement with Massachusetts Electric that both we and the utility can support. It follows the general outlines discussed previously. Because of utility support, we expect no difficulty in obtaining final approval from the State Department of Public Utilities (DPU).

(3) After further investigation of financing possibilities we are now assured that we can obtain 6-7% HEFA financing. This will be sufficient to make the project viable. At the same time, the project would be even more attractive to us if anticipated federal loan programs at 3% interest receive Congressional approval, and if we qualify, as we expect, for support from these.

(4) A revision of environmental impact assessments shows no difficulties with the proposed project.

In Section 3 we provide a preliminary design analysis that clearly defines our choice of engine and provides revised operating data in light of additional load profile studies. In particular we now find :

(1) A Sulzer #6-oil-burning 1405 KW diesel is the system of choice.

(2) The engine should be housed in a separate building in close proximity to the existing central boiler and steam distribution points.

(3) As a result of detailed summer load studies the engine as specified can be operated with higher capacity factors than anticipated in Phase I.

In Section 4 we provide a revised cost estimate using information developed in Sections 2 and 3. Compared to the Phase I report, we find no significant change in net cash flow, and an internal rate of return of 15%. In reaching this conclusion we note that increased capital charges roughly cancel decreased fuel costs arising from use of #6 oil and higher engine efficiency.

Our overall conclusion is therefore that, though some details have changed, the Clark demonstration project continues to appear highly attractive.

It should be attractive to ERDA because the grid-connection plays a pivotal role both in the choice of system and in the energy savings. Approximately 40% of the electricity output is to be exported to the utility and thus 40% of the oil savings comes directly from the grid-connection.

For Clark, the ICES is especially attractive as an investment, for reasons that go beyond its satisfactory rate of return. As discussed by L. Landry, the University's chief business officer (see Appendix 1A), the ICES offers protection against inflating energy costs by stabilizing half of the University's electrical costs. Additionally, ownership of the ICES almost completely insulates Clark from possible unfavorable changes in the utility retail rate structure. Furthermore, the demonstration would increase Clark's national visibility and add to the program in energy studies. Therefore Charles Sanders, Chairman of the Board of Trustees, and L. Landry are confident that the Trustees will vote to construct the ICES, provided the results presented here are verified in the rest of Phase II.

2. INSTITUTIONAL DOCUMENTATION

2.0 Introduction

In Phase I we identified several institutional issues which had to be resolved. These critical issues were (1) whether the University has the power to sell electricity, (2) whether we could make suitable arrangements for interchange with Massachusetts Electric that would be approved by the Massachusetts Department of Public Utilities, (3) whether we could find a suitable mode of financing the system, and (4) whether the plant would meet environmental and zoning requirements. We can now report that each of these issues has been resolved or is at least well on the way toward resolution.

2.1 Corporate Power

We had initially hoped to obtain a formal ruling from the Attorney General on whether the University as a charitable institution has the power to sell electricity. However, since we are not a government agency, we are not entitled to a formal ruling. We have instead been given an informal opinion by the division in the Attorney General's office responsible for overseeing charitable institutions. In the opinion of Assistant Attorney General Reedy (letter in Appendix 2A), "the distribution of excess energy to a public utility would be incidental to the primary purposes [of the project], and would not affect the charitable status of the University." According to the University Counsel, Richard Mirick, since this is from the division of the state government charged with supervising the conduct of charitable institutions, it is sufficient assurance that the University's power to sell electricity will not be challenged (see Mirick's letter in Appendix 2A).

2.2 Interchange Terms

The Massachusetts Electric Company has reaffirmed its intent to offer Clark terms of interchange. A letter from Mass. Electric President William Cadigan appears in Appendix 2A. A preliminary draft of the contract is given in Appendix 2B. Mass. Electric has assured Clark that while there may be minor modifications in the details of the agreement, no changes will be made that will be deleterious to the demonstration.

The agreement empowers Clark to use directly as much of the ICES electricity output as Clark needs. Only when the ICES output is insufficient for the Clark demand will Clark purchase electricity from Massachusetts Electric. Those purchases will be at the current published energy rate, C-22, together with a monthly distribution capacity charge based on contracted demand. The distribution charge is based on Mass. Electric's present distribution system costs. The present C-22 rate is also shown in Appendix 2B. When Clark makes more electricity than it can use, the excess will be sold to the utility for a price closely approximating the cost of displaced fuel. This price depends on time of day; thus there will be two prices, one for weekdays from 7:00 A.M. to 11:00 p.m., the other for the remaining times. For convenience, the price will be factored into two pieces, a multiplier times the average wholesale fuel cost. There will be two multipliers, one for peak and the other for off-peak sales. In 1974 the peak multiplier would have been 1.3; the off-peak multiplier would have been 1.06. The multipliers will be reevaluated periodically to take account of changes in the mix of generating costs. Our estimate is that based on 1977 data the multipliers will be about 5% greater than the 1975 values.

The terms of interchange must be approved by the Massachusetts Department of Public Utilities. We have spoken with the DPU and expect soon to have a timetable for obtaining DPU approval of the proposed terms. We anticipate no difficulty in obtaining approval since Massachusetts Electric strongly supports the demonstration project.

2.3 Financing

In Phase I we identified four alternative modes of financing the ICES. These were borrowing from the endowment, a commercial loan, a Health and Education Facilities Authority (HEFA) tax-exempt bond issue, and federal loan programs. We found that the last two possibilities were distinctly preferable, but we were not able to definitely determine their feasibility. At this writing we can report in relation to federal programs that we would have been eligible under last year's HUD loan program had we been ready to begin construction soon enough. The HUD program provides loans for

investments for the purpose of conserving energy in dormitories and dining facilities. Since about half of Clark's heat and electricity go to dormitories and dining (see Phase I Report, Tables 1.2.4-2 and 1.2.4-3), this program, if funded for the coming year, could provide financing at 3% for half the project cost. Unfortunately, no decision has been made yet on whether the program will be funded for the coming year. A parallel program for academic buildings under the Office of Education was not funded last year, and its prospects for this year are not easy to estimate. We are prepared to submit applications for either program the moment Congress appropriates funds to it.

Because federal financing is not certain, we have spent considerable effort in seeking approval for a HEFA bond issue. As a first step we have retained an investment broker, Marsom Pratt of Adams, Harkness and Hill, to handle the bond issue. Mr. Pratt is investment counsel to HEFA. In 1976 he developed the successful bond issue for Clark's new Student Activities Center and he is confident that a HEFA bond issue can be developed for the ICES and that it will be approved by HEFA. He recommends that we place the bonds privately, instead of having a public issue. For a private issue, Clark will not need to tie up resources in securing the bonds, and approval and placement will be easier to obtain. We will, however, have to pay a higher interest rate than the 5% we paid on the public issue for the Student Activities Center. The interest charges will not exceed 7% in any event. HEFA approval for the bond issue must come in two stages. We expect to obtain preliminary approval for the bond issue next month. Preliminary approval authorizes the preparation of a prospectus for the bond issue. We expect to obtain final approval for the bond issue after a review of the proposed prospectus. The prospectus can, however, be completed only with the preliminary design results of Phase II; consequently, final approval of the bond issue can only be obtained after the completion of Phase II. At the same time Pratt assures us that, if the cost analysis presented in part IV of this report is confirmed in the rest of Phase II, there will be no difficulty in obtaining final approval.

Pratt has also suggested the use of the leveraged lease as another mode of financing. This may offer even better terms than the HEFA bond issue. Under this plan an investor would own the facility and lease it to Clark. The investor

would be able to offer good terms because he could take advantage of tax benefits, investment tax credit, accelerated depreciation, etc., which do not apply to the University. This mode of financing was used for the Harvard Hospitals' total energy plant.

To summarize, we feel confident that we can obtain financing through a HEFA bond issue, and are taking the necessary steps to achieve this. We are continuing to pursue two alternative possibilities which might offer even better terms, namely federal loan programs and a leveraged lease. While we do not regard borrowing from the endowment as a satisfactory method of long-term financing, it is technically possible for us to borrow for this purpose, and this provides us with enough flexibility to meet unforeseen short-falls.

2.4 Environmental Impact

In Phase I we concluded that there were no insurmountable environmental barriers to the ICES. That is still our conclusion; however, the selection of a number 6-oil-burning engine has changed emission data on two counts.

(1) Emissions from the #6-burning engine contain appreciably more sulfur dioxide because of the higher sulfur content of #6 oil. While the increase is not enough to put the ICES emissions in violation of the present and anticipated air quality standards, we have, as before, requested and received explicit assurances from the Central Massachusetts Air Quality Division. (See letter from E. Benoit, Appendix 2A). A comparison of emissions from the ICES and from the present systems is shown in Table 2.4-1.

(2) Because a #6-burning engine requires fuel treatment, we plan discharge of the treatment water in the sewage system. Provided that a settling tank is used to reduce the amount of oil in the discharge, the quantities to be discharged are too small to cause any problems.

Our updated environmental impact evaluation is given as Appendix 2C.

Table 2.4-1

Estimated Air Pollution Impact--Present System and Proposed Grid-Connected ICES

System	Annual Emission (in Tons/Year)				
	SO ₂	NO _x	CO	HC ₊	Particulates
<u>Present System</u>					
Utility boiler ^a	36.2	25.2	--	0.47	1.5
Clark boiler ^b	76.9	53.4	--	1.0	3.2
System impact ^c	113.1	78.6	--	1.47	4.7
<u>ICES System</u>					
Clark diesel ^d	55.1	140.7	23.8	11.0	0.6
Clark boiler	56.9	39.6	--	0.8	2.3
Utility boiler	-21.8	-15.2	--	-.29	-.9
System impact	90.2	165.1	23.8	11.5	2.0
<u>Net Change</u>					
At Clark	35.1	126.9	23.8	10.8	-.3
% Change ^e	46.0	238.0	NA	1080.0	-9.0
Auto equivalent ^f	--	2540.0	44.0	154.0	--
New England ^g	-22.9	86.5	23.8	10.0	-2.7
% Change	-20.0	110.0	NA	680.0	-57.0
Auto equivalent ^f	--	1725.0	44.0	142.0	--

a. Based on generalized data for utility boilers burning residual oil with an ash content of 0.04% (by weight), sulphur content of 1.0% (by weight), weight of 7.83 lbs. per gallon, 148,000 Btu per gallon and a Btu to kwh ratio of 10,050 to 1. Assuming the consumption of 6.8×10^6 per year.

b. Based on the use of residual oil with the same characteristics as specified in note a and a boiler efficiency of 75%. Assuming a thermal load of 109×10^9 Btu per year.

c. Carbon monoxide levels (less than .01 tons) are considered negligible here.

d. Based on the manufacturer's specifications and the use of #6 residual oil with an ash content of 0.04% (by weight), sulphur of 1% (by weight), a weight of 7.83 lbs per gallon, and an energy value of 148,000 Btu per gallon. Assuming operation at full capacity for 7750 hours per year.

e. The percent change for carbon monoxide is meaningless since basically none was emitted previously.

f. Auto equivalents are included to provide a means of evaluating the relative significance of the net changes. They are based on EPA's estimates for the average emissions of all the motor vehicles operating in the U.S. in 1976.

g. The New England figures represent the net additional emissions of the Clark ICES and net reduction in the emissions at New England Electric System's residual oil fired generators. Assumes a net reduction in NEES's oil consumption by 279,000 gallons per year.

3. PRELIMINARY DESIGN ANALYSIS

3.0 Introduction

Our preliminary design analysis incorporates a number of changes from Phase I. We have found that our summer thermal demand is not quite what we had estimated, and the correction will enable the ICES to generate somewhat more heat and electricity. We have decided to locate the generating system in a new building outside Jonas Clark hall. Most important, we have found a diesel system which meets essentially all of the requirements we defined in the Phase I analysis. It is a Sulzer engine, Model 8 ASL 25/30; it is ebulliently cooled, burns #6 oil, and produces about 1400 KW of electricity. With the number 6-burning engine, we need one more subsystem for the conceptual design, a fuel treatment system.

In the next section, 3.1, we present our new results on thermal demand, and describe the electrical and thermal outputs of the new diesel. In section 3.2 we review the Phase I choice of system and then give our reasons for selecting the Sulzer engine and the new location. In section 3.3 we describe the changes needed in the conceptual design to accommodate the new engine and location.

3.1 Energy Load Profiles

The electricity load profile presented in our Phase I report was based on several years of recorded data. Since our recent data is consistent with the previous records, we have not altered our estimated electricity load profile; it is reproduced in Figure 3.1-1. That profile contains an estimated contribution from the new gym; we will have data on its actual contribution as soon as it begins to be used, in less than a month.

The thermal load profile presented in the Phase I report used estimated summer thermal demands. We now have data on thermal demand for this summer and this changes somewhat our previous estimate. We have found that at present summer thermal demand is considerably more uniform than we had estimated. The revised profile is presented in Figure 3.1-2. As with the electrical profile, we have estimated the contribution of the new gym and we will be able to test this estimate in the next few months. The added demand in summer nights means that we will be able to operate the ICES, at

Fig. 3.1-1: Electricity Load Profile

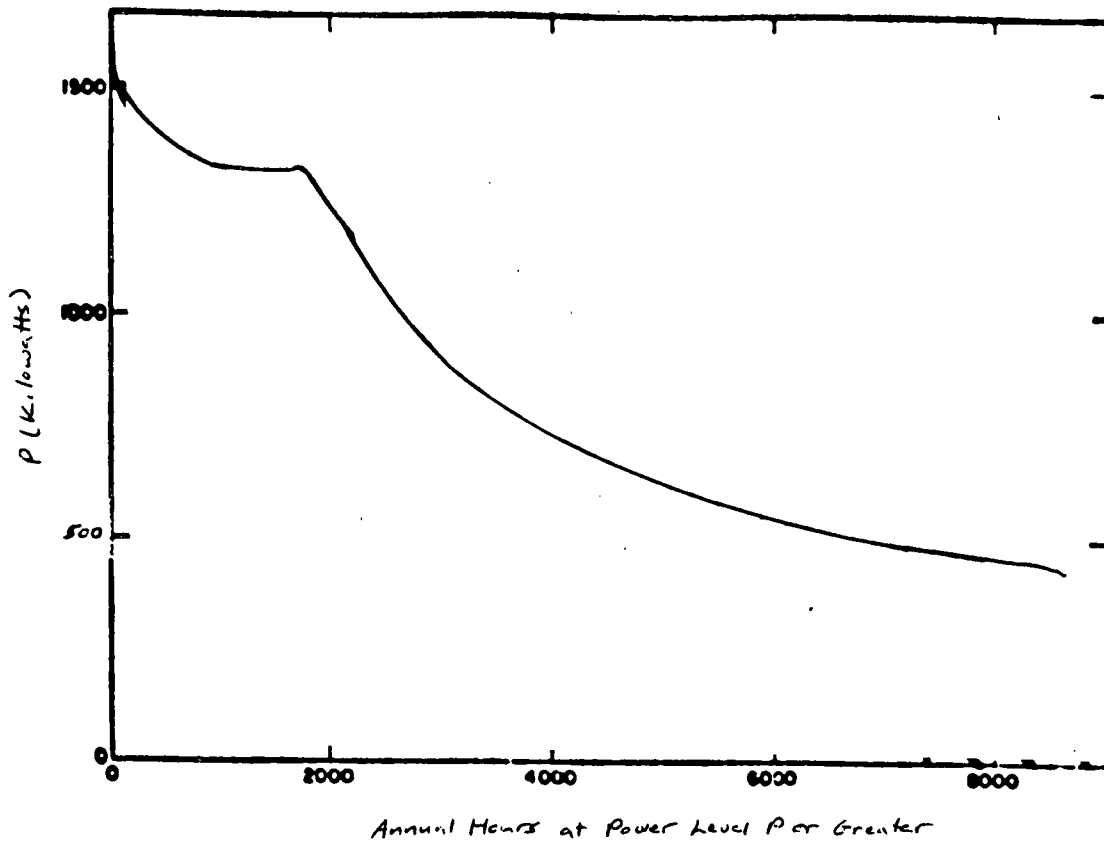
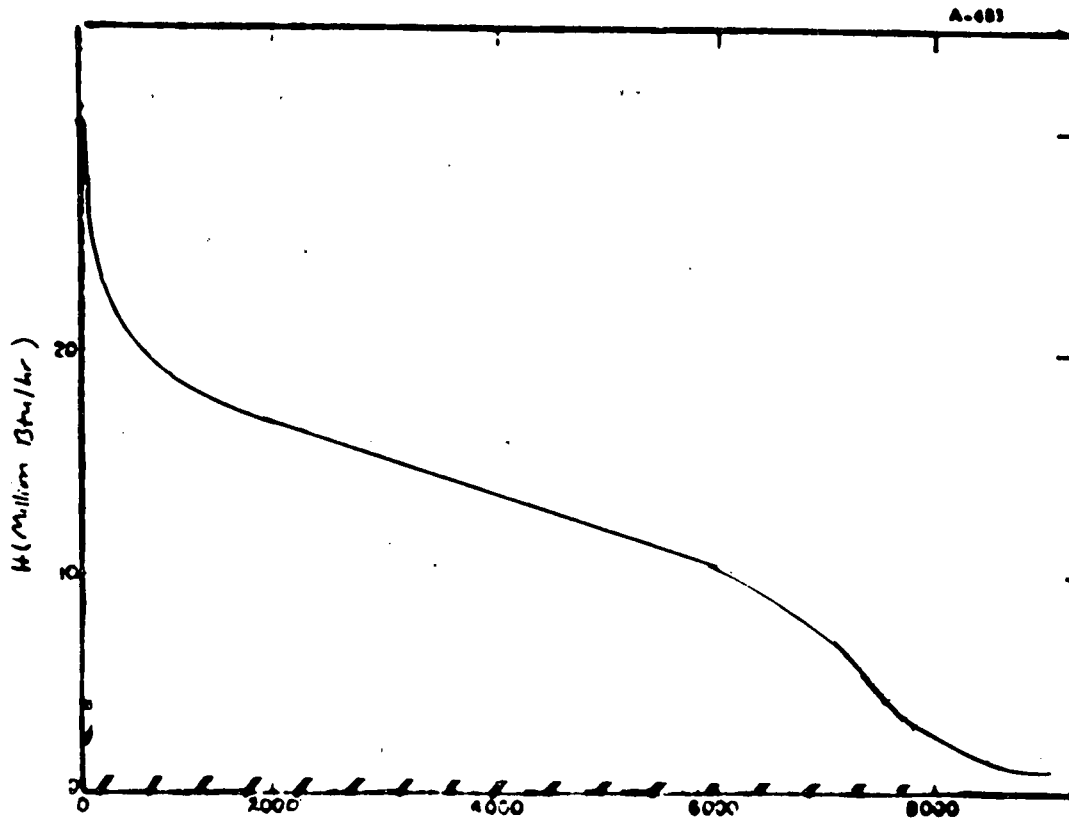

Fig. 3.1-2: Revised Thermal Load Profile



part load, for many summer nights, and the overall output of the system could be somewhat greater than our previous estimate.

We repeat the thermal and electric load profiles in Fig. 3.1-3; shown on these profiles are the electric and thermal outputs of the Sulzer 1405 KW engine. Except for summer nights and brief periods for maintenance, the engine operates at full load continuously. The overall fuel saving we expect is about 250,000 gals/yr oil saved by Clark and the electric utility. Notice that the grid-connection, in addition to its other benefits, gives rise to about 40% of those savings.

3.2 Design Options and Final Choice of Engine

We have decided to put the generating plant in a new building adjacent to the boiler room in the basement of Jonas Clark hall. This location is preferable to a location inside Jonas Clark, because (1) it avoids major problems with noise and vibration insulation; (2) it does not eliminate classroom space; (3) it will be much easier to make the demonstration system accessible and attractive for public viewing. The disadvantage of the choice is that it adds significantly to the capital cost of the project (see section 4.1 and Appendix 4A). We believe that the advantages more than make up for the extra cost.

In Phase I we concluded that the optimum ICES for Clark would use a single diesel engine, ebulliently cooled, burning residual oil, with a maximum electricity output of about 1500 KW and a maximum recoverable heat output of about 4 million Btu/hr. We reached this conclusion after examining a variety of diesel engines in various configurations along with representative steam turbine systems and gas turbine systems. We have reviewed that analysis for this report and found it still correct. Steam turbines small enough for Clark's heat demand simply do not make enough electricity to finance them. Gas turbines suited to our size burn distillate oil and have slightly poorer performance characteristics than comparable light-oil-burning diesels. Ebullient cooling is necessary because the University has a steam heating system and it would be prohibitively expensive to make the modifications needed for heating some buildings with hot water. There are two advantages to burning residual oil: it is significantly cheaper, and

Fig. 3.1-3: Electric and Thermal Outputs of Sulzer Engine
a. Electricity Output

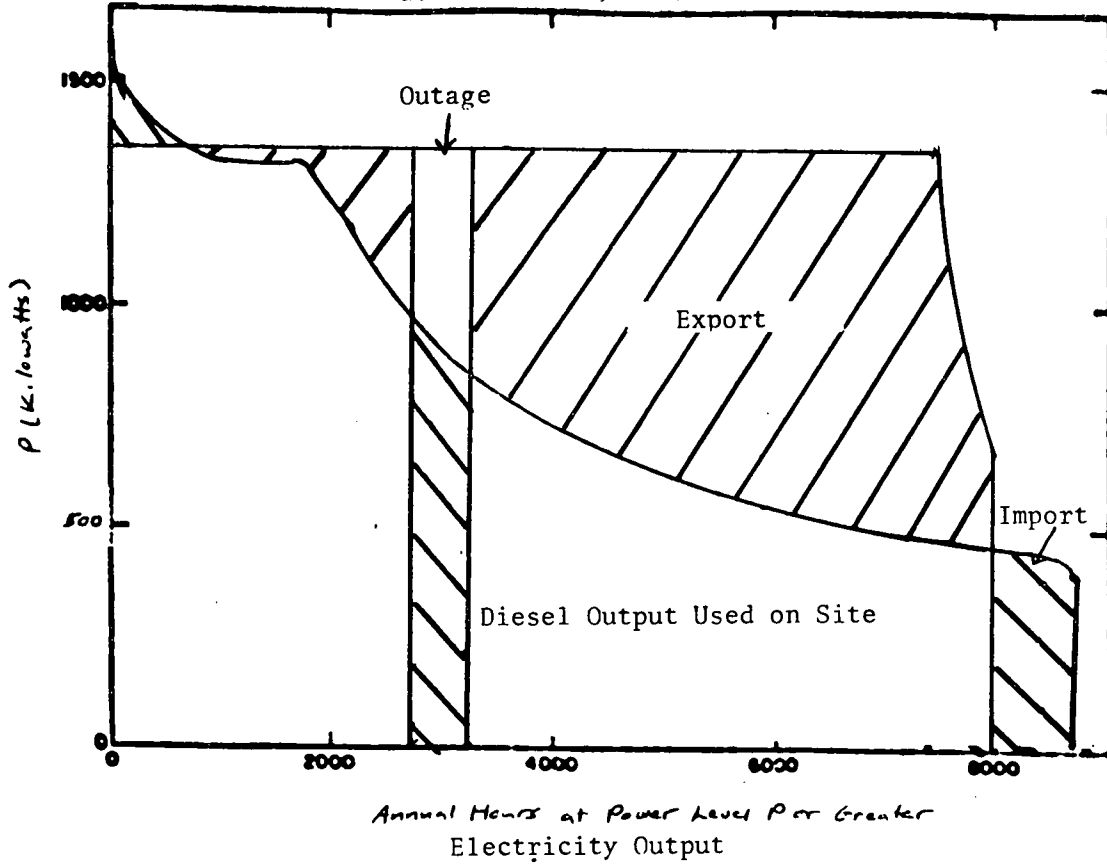

b. Thermal Output

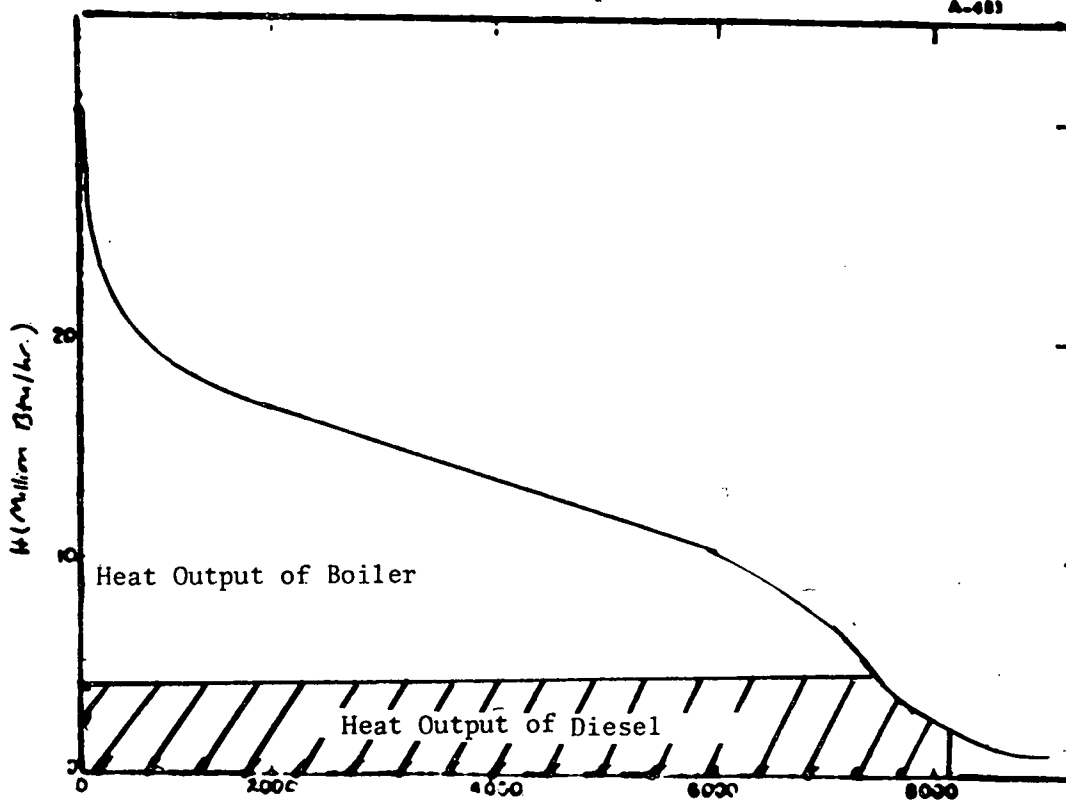

it is in the national and regional interest not to add to the pressure on the demand for light oil and gas. Grid-connection obviates the need for multiple engines as we don't have to follow Clark's electrical demand and as we are not considering engines large enough to require extensive variation of heat output. Finally, the size of the generating system is fixed by economic considerations. While it is profitable to sell excess electricity to the utility, it is not sufficiently profitable under the present terms to finance capacity which is solely for exports. Thus the optimum generator will produce approximately as much electricity as will meet Clark's peak electrical demand.

In Phase I we made our analysis using a diesel generating system which met all of the above requirements except for one; the engine burned only distillate oil, not residual oil. Since then we have identified two candidate diesels of the right size which can burn residual oil and be cooled ebulliently. These are a 1400 KW engine made by Sulzer, model 8 ASL 25/30, and a 1500 KW engine made by Cooper Bessimer, Superior model 40-X-16. The Sulzer engine is normally water cooled, not ebulliently cooled; however, the Sulzer Company assures us that the alterations are minor ones and that they are happy to maintain their standard one-year guarantee. The Superior engine normally burns distillate oil; the manufacturer, Cooper Energy Systems, is willing to modify the engine to burn residual oil. They too will maintain their one-year guarantee, with the proviso that the fuel entering the engine be carefully monitored to ensure strict limits on sodium and vanadium in the fuel.

Since both manufacturers are confident that the modifications will not impair the performance of the engines and since they will guarantee the engines, we feel that both engines are viable options. Since they offer a significant economic advantage over the distillate-fired engine, we would prefer one of them as the generator for the grid-connected ICES. It is worth noting that, according to Thermo-Electron, both manufacturers have thoroughly competent field service representatives. Sulzer's U.S. service is performed by Golten Marine, Brooklyn, New York, who have worked many years on residual-burning marine diesels. Superior has their own field service team which also has much experience.

We chose the Sulzer engine in preference to the Superior for the following reasons. (1) We believe that the burning of residual oil is a more sensitive modification than the change to ebullient cooling. Sulzer has both laboratory and field experience with burning #6 oil in that engine. That experience is summarized in Appendix 3A. (2) Sulzer places less stringent limits on vanadium and sodium than Superior. (3) The Sulzer engine gives a slightly better return on investment (see section 4.3). (4) The Sulzer engine is smaller and will be easier to install.

Each of these is a small consideration, but taken together they lead to a clear preference for the Sulzer engine.

3.3 Update of Conceptual Design

The conceptual design section of the Phase I report has to be modified to take account of (1) the new choice of diesel engine, (2) the need for a fuel treatment system for #6 oil, and (3) the decision to place the system in a new location.

In Appendix 3B we give a detailed description of the two candidate #6-burning engines, Sulzer and Superior, and compare them with the #2-burning Fairbanks Morse. The #6 oil engines differ from the #2-burning engine described in Phase I in requiring a #6 fuel treatment system and a separate set of #2 oil storage and day tanks for starting and stopping. The steam and electrical systems are the same for all engines. In Appendix 3C we present details of their performance, including heat balances at 100% and 50% loads. Engine performance deteriorates only slightly down to 50% load; it falls off rapidly for lower loads. Performance characteristics at 100% load are summarized in Table 3.3-1. Heat and electric outputs of all three engines are similar; however, because #6 oil is cheaper and is the fuel now used in the boiler system, the #6-burning engines have appreciably lower fuel costs, about 5.5 mills/kwh less than the #2-burning engine.

In Appendix 3D we give specifications and operating characteristics for the fuel treatment system. The system removes sodium by demulsifying and centrifuging; this also removes most other metals. It then neutralizes the damaging vanadium compounds by combining the vanadium with the magnesium to make magnesium vanadate, which is not damaging to the engine at the diesel

operating temperature. These properties are summarized in Table 3.3-2.

Table 3.3-1: Performance Characteristics of Three Diesel Engines

	<u>Sulzer</u>	<u>Superior</u>	<u>Fairbanks-Morse</u>
Fuel	#6	#6	#2
Maximum Electrical Output	1405 KW	1500 KW	1531 KW
Thermal Output	3.6×10^6	5.2×10^6	4.0×10^6 Btu
Low pressure steam	1.3×10^6	2.5×10^6	1.0×10^6 Btu
High pressure steam	2.3×10^6	2.7×10^6	3.0×10^6 Btu
Electric Efficiencies	38%	32%	36%
Thermal Efficiencies	40%	49%	42%
Heat Rate	8970	10,700	9500
Incremental Heat Rate with Heat Credit	6050	6150	6280

Table 3.3-2: Properties of Fuel Treatment System

Impurity	Sodium (Na)	Vanadium (V)
Impurity content of Typical Fuel	150 ppm	150 ppm
Impurity Content of Treated Fuel (for Sulzer engine)	<30 ppm	<100 ppm
Treatment	Demulsification followed by centrifuging	Formation of harmless magnesium vanadate
Treatment Chemical	Tretolite RI-35 or Nalco 9-533DA	Tretolite KI-16
Dosage	--	3.2/1 Mg/V

Figure 3.3-1 shows a sample layout for the components of the system using the Sulzer engine and including the fuel treatment system. It is set in a new building 60' x 37' x 24'. This figure also shows the location of the building relative to the Goddard Memorial now under construction. The building location and shape is chosen to obtrude as little as possible on the memorial.

FIGURE 3.3-1
Location of Proposed Building and
Goddard Memorial, West Base
System Layout

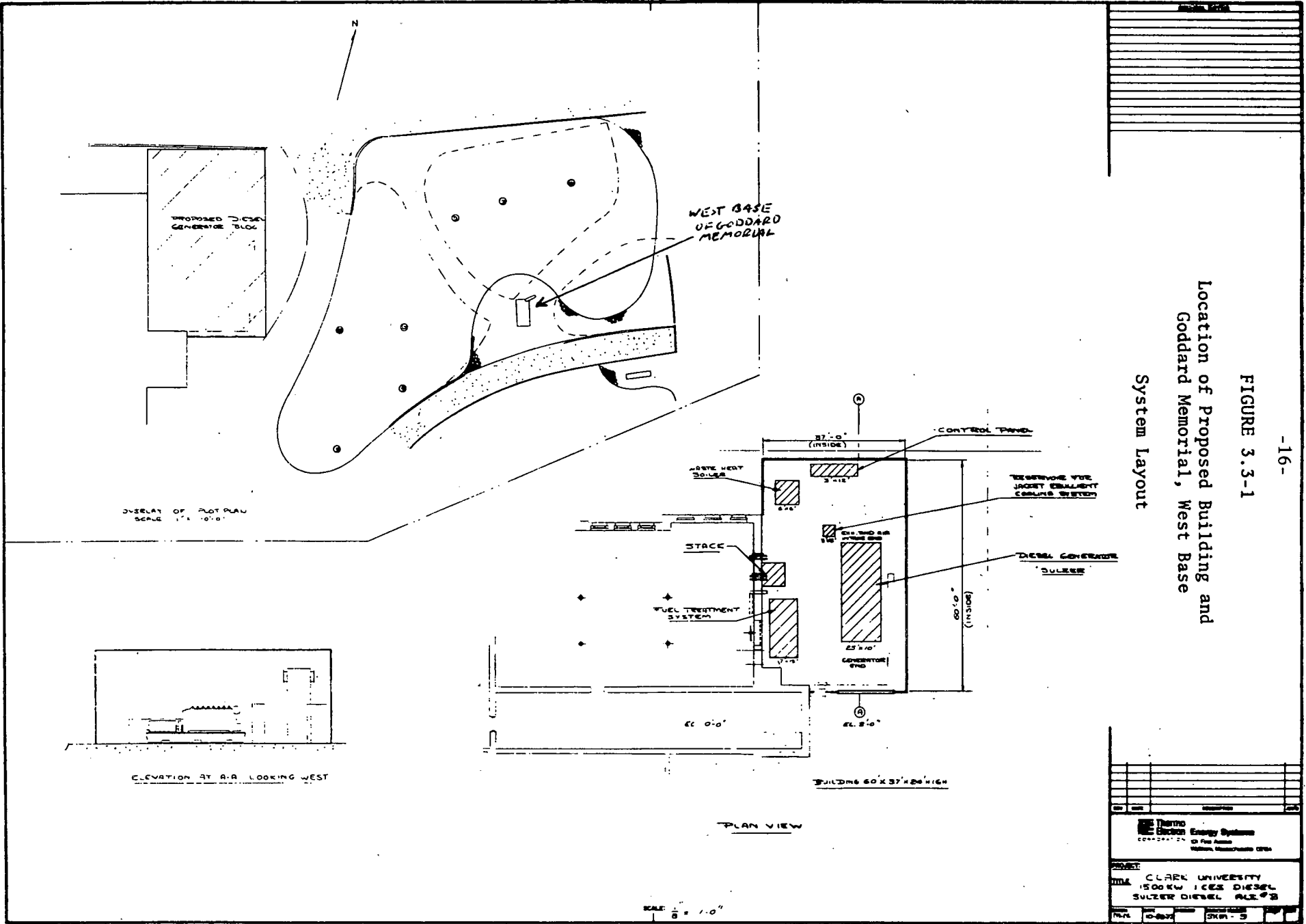

4. COST ANALYSIS

4.0 Introduction

There are two substantial changes in the cost analysis of our Phase I report. (1) Capital costs have increased. Because of uncertainty in federally subsidized financing programs, we take 6% as a base case interest rate. The combined effect is to raise annual capital charges by \$63,500. (2) We have identified a suitable #6-oil-burning engine. The effect of this is to reduce fuel costs by \$56,700 per year. In addition, our new analysis contains some minor changes. There are additional maintenance costs associated with burning #6 oil; as a result of further monitoring, we find we can run at half power on most summer nights; and we have refined our evaluation of the utility standby charge. Taken together, both major and minor changes give net cash flows similar to those obtained in Phase I.

We discuss capital and operating costs in the next two sections. In section 4.3 we compare the ICES with the conventional system and show that the internal rate of return is about 15%. We also discuss the sensitivity of the analysis to our assumptions. Finally, in section 4.4 we discuss other features of the ICES which make it an attractive investment.

4.1 Capital Costs

Capital cost summaries for three systems, the Sulzer 1405 KW engine, the Superior 1500 KW engine, and the Fairbanks-Morse 1531 KW engine, are shown in Table 4.1-1. Detailed cost breakdowns appear in Appendix 4A. The total capital cost for our selected system, the Sulzer 1405 KW engine, is \$1,380,000, compared to the \$820,000 Phase I estimate of cost for the Fairbanks-Morse 1531 KW system. An analysis of the cost increase follows: (1) Clark's decision to use a new building for the plant adds about \$200,000 to the cost; (2) a fuel treatment system for #6 oil adds about \$100,000 to the cost; (3) a more expensive engine adds about \$100,000 to the cost; and (4) miscellaneous extra equipment and engineering costs not considered in Phase I add about \$150,000 to the estimate. Only (1) and (4) apply to the Fairbanks-Morse engine, so its revised capital cost is \$1,190,000. Table 4.1-1 also shows the yearly finance costs assuming level payments on a 20-year note at both three percent and six percent interest. The

TABLE 4.1-1
Capital Cost Summary

	Sulzer	Superior (Costs/\$1000)	Fairbanks Morse
Equipment and Mechanical Work	869	807	681
Civil Work	255	255	255
Electrical Work (not including grid connection)	51	51	51
Engineering Cost	207	207	200
Total Cost to Clark	1382	1320	1187
Grid Connection Equipment	40	40	40
Monitoring Equipment	35	35	35
Engineering	15	15	15
Cost to ERDA	90	90	90
Clark Yearly Payments at 6% Level Loan	118	113	102

yearly costs for the Sulzer would be \$91,000/yr and \$118,000/yr, respectively. The Fairbanks-Morse costs would be \$78,000 or \$101,000. Going from 6% to 7% financing would place the Sulzer capital costs at \$128,000/year.

In the remainder of Phase II we will refine these cost estimates. We will also evaluate the escalation of the costs through the construction period.

4.2 Fuel and Maintenance Costs

Fuel costs with heat credit for the three engines are evaluated in Table 3.3-1 and Appendix 3C. These are summarized in Table 4.2-1:

Table 4.2-1: Fuel cost and heat credit

Engine	Fuel cost (mills/kwh)	Heat credit (mills/kwh)	Net fuel cost (mills/kwh)
Sulzer 1405 KW	22.4	7.3	15.1
Superior 1500 KW	26.7	11.4	15.3
F & M 1531 KW	28.5	8.0	20.5

Note the much greater net fuel cost of the Fairbanks-Morse engine, because it burns more expensive #2 oil.

We constructed Table 4.2-1 assuming that the price of #6 oil to Clark would be \$2.50/10⁶ Btu, and the price of #2 oil would be \$3.00/10⁶ Btu. The present prices are \$2.20/10⁶ Btu and \$2.65/10⁶ Btu, respectively. The increase is based on the assumption that oil prices will show the same seasonal change this year as last.

Maintenance costs for the three engines are summarized in Table 4.2-2.

Table 4.2-2: Maintenance Costs

	<u>Yearly Cost \$</u>		
	<u>Sulzer</u>	<u>Superior</u>	<u>Fairbanks- Morse</u>
Diesel Engine	41,900	45,000	37,000
Fuel Treatment	5,400	15,400	--
Miscellaneous	9,000	9,000	7,000
TOTAL	<u>56,300</u>	<u>69,400</u>	<u>44,000</u>
Cost/kwh	5.7 mills/kwh	6.6 mills/kwh	4.0 mills/kwh
3 % Increase	5.9	6.8	4.1

The derivation of these cost estimates is given in Appendix 4B. The estimates include diesel manufacturer's recommended maintenance and cost experience, chemicals for fuel treatment, and a safety margin.

For the economic comparison in section 4.3, we have assumed 6% inflation and thus estimate a 3% increase in average cost. Notice that burning #6 oil increases maintenance costs both by the cost of chemicals for fuel treatment and by increased wear on the engine.

4.3 Comparison with the Conventional System

In Table 4.3-1 we list the base-case assumptions we have made about costs which we will use to compare the grid-connected ICES with the conventional system. We assumed that the ICES was completed today at the capital cost of section 4.1, that fuel prices for the coming year will show the same seasonal variation as last year, and that all costs will escalate at 6%/yr. We show later in this section that the results do not depend drastically on the assumptions.

We list in Table 4.3-2 the energy output of the ICES used at Clark and sold to the utility. These numbers are taken from the energy outputs described in section 3.1. There is one complication, however; because the standby terms require only that Clark pay at least a minimum charge each month, Clark has available a certain amount of "free" electricity, that is,

Table 4.3-1: Base case assumptions

Variable	Value
Rate of inflation	6%/yr
Price of fuel (anticipated)	
#2 oil	\$3.00/MBtu
#6 oil	\$2.50/MBtu
Prices of electricity (anticipated)	
Purchased by Clark	4.45¢/kwh
Sold by Clark, weekdays 7 A.M. - 11 P.M.	2.60¢/kwh
Sold by Clark, other	2.15¢/kwh
Standby Minimum	\$32,000/yr
Retail rate structure multiplier	1.2
Plant lifetime	20 years
Clark electric demand	6.9×10^6 kwh/yr
Conventional boiler efficiency	75%

electricity which it has already paid for by paying the minimum. That electricity can have two values; one is a value equal to the present retail price of electricity when it replaces electricity that Clark would purchase anyway, and the other is a value equal to the operating costs of the ICES when it replaces ICES-generated electricity. Our estimates for each quantity of electricity are also shown in Table 4.3-2. We expect that there will be approximately $.55 \times 10^6$ kwh of free electricity. About $.3 \times 10^6$ kwh will replace electricity that Clark would purchase anyway and about $.25 \times 10^6$ kwh will substitute for ICES generated electricity. The ICES will generate in all about 10.4×10^6 kwh of which 4.2×10^6 kwh will be sold to the utility.

We are now ready to compare the costs of the ICES with the costs of the conventional system. The comparison is made in Table 4.3-3. Under the base assumptions, the Sulzer 1405 KW engine has a first-year operating savings of about \$148,000/yr, and net savings after payment of financing costs of about \$30,000/yr. By the tenth year we project these savings to be approximately \$270,000 and \$150,000, respectively. The projected base-case yearly savings for the three engines are shown in Figure 4.3-1.

Table 4.3-2: Electricity and Thermal Outputs

ELECTRICITY

1. Clark total demand	6.9x10 ⁶ kwh
2. Clark demand supplied by diesel	6.2
3. Clark demand supplied by purchases up to minimum standby payment	.55
a. Minimum purchases replacing retail purchase	.25
b. Minimum purchases replacing ICES generation	.30
4. Clark demand supplied by additional purchases	.15
5. Diesel-produced energy sold to utility	4.2
6. Total production by diesel	10.4
7. Maximum possible production by diesel	12.5
8. Capacity factor	83%
9. Outages for maintenance and certain summer nights	8%
10. Operation at de-rated power level (average 65% full load)	12%

HEAT

11. Clark total demand	11x10 ¹⁰ Btu
12. Clark demand supplied by diesel	2.6x10 ¹⁰ Btu

FUEL SAVINGS

13. Savings at Clark plus savings at utility due to reduced generation	3x10 ¹⁰ Btu
--	------------------------

It is clear that the residual-oil-burning engines are preferable to the distillate-oil-burning engine; the Sulzer engine has a slight lead over the Superior.

We have examined the sensitivity of the projected savings to the values of our base case parameters. In Table 4.3-4 we list the key parameters and the sample variations we have used to test the sensitivity of the savings. Figure 4.3-2 shows the variation of the Sulzer engine savings with each of the changes. The total variation is taken to be the square root of the sum of the squares of each individual variation. The savings are always

Table 4.3-3
FINANCIAL ANALYSIS OF THE SYSTEM

	<u>Sulzer</u>	<u>Superior</u>	<u>Fairbanks- Morse</u>
A. DIESEL PLANT	(in units of \$1,000)		
1. Capital cost	118	113	102
2. Fuel cost	233	299	297
3. Maintenance costs	61	76	43
4. Gross operating costs	294	375	340
5. Heat credit	76	128	83
6. Standby charge	32	32	32
7. Purchases over standby minimum	7	7	7
8. Operating costs	257	286	296
B. UTILITY PRICE ARRANGEMENTS			
9. Price of electricity sold to Clark under conventional system	307	307	307
10. Credit for electricity sold by Clark to utility under proposed system	97	115	97
11. Operating credits	404	422	404
C. FIRST YEAR BENEFIT TO CLARK			
12. Net operating savings	147	138	97
13. Net savings	29	25	-5
D. FUTURE BENEFITS			
14. Yearly benefit in fifth year	80	75	30
15. Yearly benefit in tenth year	150	142	75
16. Integrated 10-year benefits	828	800	350
E. PAYBACK			
17. Years to pay back loan if all savings used to reduce debt	9.2 years	9.5 years	13.0 years
18. Internal rate of return	15%	14.3%	12.2%

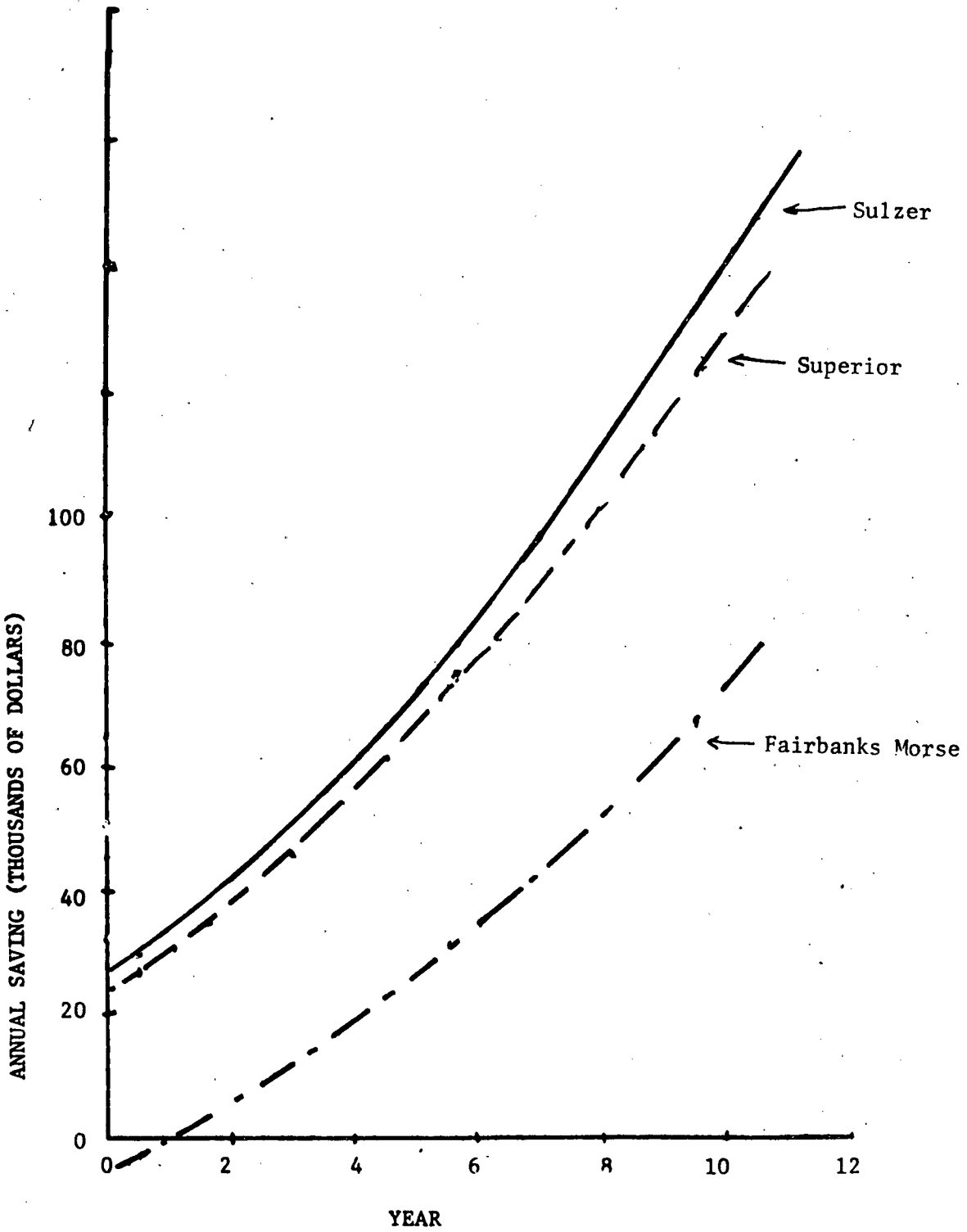

Figure 4.3-1
Projected Base-Case Yearly Savings

TABLE 4.3-4
Key Parameters for Sensitivity Analysis

Key Parameters	Base Value	Variation Tested
Efficiency of Clark Boiler	.75	.85
Interest Rate on Loan	.06/yr	.03-.07/yr
Retail Electricity Rate Multiplier	1.2	1.35 (flat rate is 1.5)
Rate of Fuel Price Escalation	.06/yr	0.0-.12/yr
Additional Credit for Exports	0	.3¢/kwh
Underestimate of Capital Costs	0	\$200,000
Inflation Rate	.06/yr	.03-.09/yr

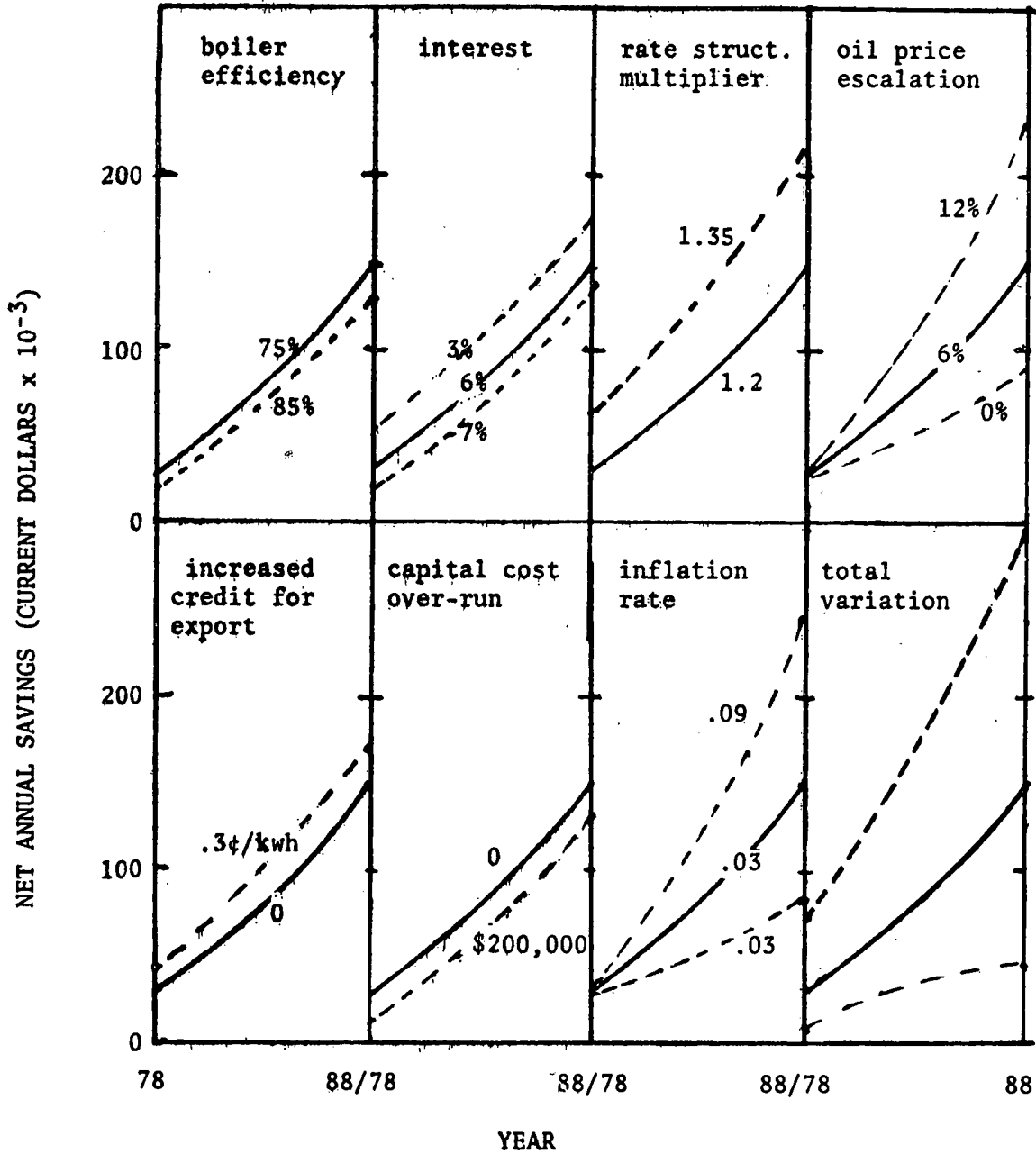

Fig. 4.3-2: Sensitivity of savings for the Sulzer engine burning #6 oil. Base case is shown as solid line, variation by dotted line. The variation used is defined in Table 4.3-4.

positive even for the total variation, so there is little risk to be expected from the variation of those parameters. Note that flattening of the retail electricity rate structure could cause a big increase in the savings.

4.4 Evaluation of the Investment

The anticipated 15% internal rate of return with the reasonable assurance of positive net savings is enough to make the grid-connected ICES an attractive investment for Clark. In addition, as pointed out by the University business officer, L. Landry, the investment in the ICES is a hedge against the inflation of energy costs (see his letter in Appendix 1A). If about half of the electricity generation costs are fixed as capital costs, only the remaining half are subject to inflation. Thus the costs using the ICES will rise much more slowly than costs for the conventional system as oil prices go up. Of course, costs would decline less rapidly if oil prices dropped, but we consider that much less likely. Furthermore, by generating most of its electricity, the University would be almost completely insulated from unfavorable changes in electricity rates. It is certain that electricity rates will change in the next year, as the DPU has required utilities to introduce time-of-day rates. It is not certain that the changes will be unfavorable to Clark, but it is likely. The University now benefits from sharply declining block rates (see Appendix 2B), and there is both state and federal pressure for flattening rate structures. Furthermore, the University does not have much flexibility for shifting more electric use to the nighttime and so it could be hurt by very high peak rates.

Thus we consider the ICES an attractive investment on two grounds. It offers a decent rate of return with only modest risk, and it helps protect the University from potential unfavorable changes in energy prices. Along with these benefits Clark would benefit significantly from being a demonstration site. The demonstration would give Clark national visibility and would give a major boost to our research and teaching in energy studies.

APPENDIX 1A

Letter from Lawrence Landry,
Vice President of Business and Finance
and Treasurer

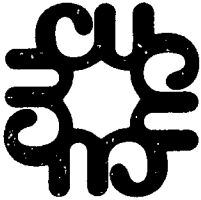

Clark University WORCESTER, MASSACHUSETTS 01610

OFFICE OF THE TREASURER

617-793-7443

4 November 1977

TO: Frank Puffer, Director ICES Study

FROM: Lawrence L. Landry *Lawrence L. Landry* Vice President of Business and Finance
and Treasurer

I would like to summarize my findings to date as to the financial desirability of the proposed ICES to service the Clark University campus. The economic analysis can be stated in several ways, depending upon the assumptions one wishes to use about future operating and final capital costs for constructing the ICES. For my purposes, I am assuming a \$1,400,000 capital investment will be required and that prior to debt service payments, first year savings in operating costs will be \$148,000. Assuming a 6 percent inflation factor, the savings will rise to \$199,000 by the fifth year and \$269,000 by the tenth year. Overall the analysis indicates a nine to ten year payback period. These numbers are sufficiently attractive to warrant an investment by Clark.

As you know, the Executive and Finance Committee reviewed the preliminary findings last summer and felt that the investment was attractive enough to continue our study. Recently I have shared our updated numbers from the economic analysis with Charles Sanders, Chairman of the Trustees' Finance Committee. He shares my enthusiasm for proceeding with the project. We would expect that if the findings to date are verified in the course of our Phase II study that the Trustees would vote to construct the ICES.

Perhaps it would be helpful for you and other members of the research team to understand the reasons for our enthusiasm. Aside from the initial cost savings, our interest in the cogeneration plant has a direct relationship to the overall financial situation at the University. The basic problem in Higher Education is that the costs per student have been rising at a greater rate than the income per student. In other words, a University is much more vulnerable to inflation than an enterprise that has productivity increases through the use of new technology. Because of this reason as well as our labor intensity, Clark has developed the philosophy of making prudent investments which at least result in fixing our costs at current levels.

The cogeneration project is an excellent example of the type of investment which can help further control costs. To date, the University has an outstanding record in the field of energy management. For example, since the first oil embargo we have reduced electrical and heating consumption by 35 percent. However, costs continue to escalate. An added attraction of the proposed plant is that it would insulate a substantial portion of the University's energy costs from inflation. Currently 100 percent of our energy bill is subject to inflation; with cogeneration, about 50 percent of energy costs would be affected by inflation. Furthermore, and I expect much more significant, is the fact that the project will provide a perfect defense against electrical cost increases that would result from alteration in the current price structure of electricity. Under the existing price structure, the unit cost of electricity declines as consumption increases. However, we seem to be moving toward a "flat rate" or "peak load" formula for pricing electrical power. These or similar changes would increase the unit cost of electricity to Clark. However, with a cogeneration plant, the University would be less vulnerable to these cost shifts.

Another consideration in evaluation of an investment in the ICES is that unlike industrial concerns, the University does not have alternative investments that could yield the same benefit. This fact as well as the opportunity to finance completely through debt makes the investment that much more attractive. In connection with financing the plant, I am quite optimistic that funds can be raised at a cost not to exceed 7 percent. Although our first preference for financing would be from federal programs, we are also developing a fallback position in case federal funds are not available. We are pursuing two alternative routes of financing and are receiving advice from an investment banker; namely, Adams, Harkness & Hill. Mr. Marsom Pratt from this firm has worked previously with the University and assisted us in placing a tax-exempt bond issue in August 1977 for \$2,200,000 at a net interest cost of 5 percent through the Health Educational Facilities Authority (HEFA).

Alternative to federal financing is to use tax exempts through the HEFA Authority. I have discussed this option with Samuel C. Brown, Executive Director of the Authority and he is optimistic about our possibilities for financing the plant. Accordingly, he has asked Marsom Pratt to work with us in evaluating our study and developing a tax-exempt package.

A further alternative to a tax-exempt bond issue, we are also exploring financing through a leveraged lease. Recently, Harvard University successfully financed a generation plant by using this method. Adams, Harkness & Hill is a highly regarded firm with many contacts and I believe that they will successfully finance the ICES plant for the University.

Although I expect that one of the above-mentioned financing routes will eventually be approved by the Clark Trustees, I should point out that the Board could elect to borrow from endowment funds and in that respect provide self-financing. The final decision on financing, however, will be made in conjunction with the final plans for the plant. In other words, once we have fixed a time schedule and capital costs, the Trustees can then commit the University to a particular financing package.

LLL/pa

APPENDIX 2A

Letters from:

Mary Joann Woods Reedy, Assistant Attorney General, Division of
Public Charities

Richard W. Mirick, Mirick, O'Connell, DeMallie and Lougee, Counselors
at Law

Ronald W. Plutnicki, Consumer Services Consultant, New England
Power Service Co., NEES

Edmund G. Benoit, Chief, Air Quality Control Section .



THE COMMONWEALTH OF MASSACHUSETTS
DEPARTMENT OF THE ATTORNEY GENERAL
JOHN W. MC CORMACK STATE OFFICE BUILDING
ONE ASHBURTON PLACE, BOSTON 02108

FRANCIS X. BELLOTTI
ATTORNEY GENERAL

October 21, 1977

Richard W. Merick
Merick, O'Connell, DeMallie and Lougee
1700 Mechanics National Tower
Worcester, MA 01608

Dear Mr. Merick:

You have requested the opinion of this office on the legal power of Clark University to engage in the construction and operation of an integrated community energy system (ICES).

Upon review of your letter and the attached charter and feasibility study it is my conclusion that the primary purposes of the project will advance the charitable purposes of the University. The distribution of excess energy to a public utility would be incidental to the primary purposes, and would not affect the charitable status of the University. Conklin v. John Howard Industrial Home, 224 Mass., 222 (1916); McKay v. Morgan Memorial Goodwill Industries, 272 Mass. 121 (1930).

Sincerely,

A handwritten signature in cursive script that reads "Mary Joann Woods Reedy".

Mary Joann Woods Reedy
Assistant Attorney General
Division of Public Charities

MJWR/kah

MIRICK, O'CONNELL, DEMALLIE & LOUGEE
COUNSELORS AT LAW
1700 MECHANICS NATIONAL TOWER
WORCESTER CENTER
WORCESTER, MASS. 01608
617 799-0541

November 4, 1977

Lawrence L. Landry, Vice President for
Business and Finance
Clark University
950 Main Street
Worcester, Massachusetts 01610

Dear Mr. Landry:

I suggested to you some time ago that if the University proceeded with construction and operation of a grid-connected integrated community energy system, and sold any excess electricity to the local public utility, it might be argued that the University as an eleemosynary institution did not have the legal power to manufacture and sell electricity.

I am happy to report that discussion and correspondence with the Division of Public Charities of the Department of the Attorney General of the Commonwealth of Massachusetts has resulted in a response indicating that the project would not affect the charitable status of the University. I am attaching a copy of the letter from Assistant Attorney General Reedy.

The Division of Public Charities is the agency which represents the public interest in matters involving the charitable status of eleemosynary institutions. In view of her letter I do not anticipate any questions from any other state or local government source as to the University's legal power to proceed with the project as planned.

Very truly yours,



Richard W. Mirick

RWM/pjb
Enc.



Massachusetts Electric

Massachusetts Electric Company
939 Southbridge Street
Worcester, Massachusetts 01610
Tel. (617) 791-8511

William J. Cadigan
President

February 16, 1978

Dr. Frank W. Puffer
Dean of Academic Affairs
Clark University
950 Main Street
Worcester, Massachusetts 01610

Dear Dr. Puffer:

Clark-DOE Demonstration Program of a
Grid-Connected Integrated Community
Energy (Cogeneration) System

I have been advised of your recent meeting with Clark's Board of Trustees concerning the status of the subject program. Apparently, some of the members of the Board are unsure of Massachusetts Electric Company's position relative to its support of Clark's proposed Cogeneration project.

Let me assure you that my Company's position toward this project has not changed since we agreed to become an active participant in your proposed program to DOE back in November of 1976. We have expended much time and effort in the development of the Phase I Report, as well as the soon to be completed Phase II Report; and, offer the same continued effort through the remaining Phases of work toward a successful completion of the demonstration facility.

It is important to note that our parent company, New England Electric System, has committed itself to the national energy conservation program. This has been demonstrated by undertaking various studies to evaluate the long range benefits of energy conservation programs. One such effort is our Solar Water Heating Experiment. This demonstration program was designed to test the suitability of solar water heater systems to help meet the energy needs of New England and their possible future integration with utility operations. Cogeneration of heat and electricity at an industrial or institutional site offers a great potential for energy conservation through improved overall efficiency.

However, many economic, technical and institutional factors will impact the future of cogeneration. These factors must be studied and carefully evaluated before the cost/benefit ratio of the cogeneration potential can be determined.

Dr. Frank W. Puffer, Clark University

February 16, 1978

In order to properly evaluate these factors, it is essential that my Company have some experimental installations in our service area to accumulate valuable operating information. We have recently completed a survey, designed to assess the potential of cogeneration with a further attempt to identify a class of cogeneration customers.

As a member of the Task Force, we have benefited greatly from the input of the other members. We have used this input in our work to develop a policy and cogeneration rate. The information gained in the following phases of work would be most valuable in assessing the cogeneration potential.

We are now studying the long range potential economic benefits of the Cogeneration capacity. The value of this cogeneration capacity will be greatly affected by its availability, its fuel economics, and the manner in which it is dispatched. The Clark Project will be valuable in terms of the information provided by the operating experience of the facility.

We are hopeful that the Clark Cogeneration Demonstration Program will proceed on schedule; and, we continue to support its successful completion.

Very truly yours,

William J. Cadigan



The Commonwealth of Massachusetts

Department of Environmental Quality Engineering

Central Massachusetts Air Pollution Control District

75 Grove Street

Worcester, Massachusetts 01605

TEL. (617) 791-3672

November 4, 1977

Mr. Lawrence Landry
Vice President of Finance
Clark University
950 Main Street
Worcester, Massachusetts 01610

Dear Sir:

On November 3, 1977, I met with Mr. Robert Caiazzo, student, at Clark University, regarding the proposed Inter Connected Energy System (ICES) for Clark University, 950 Main Street, Worcester, Massachusetts.

As was explained to Mr. Caiazzo, the Worcester area is non-attainment for total suspended particulates, oxidants, and carbon-monoxide. The recently enacted Clean Air Act of 1977 specifically addressed the problems for non-attainment regions. In addition, the Act requires actions to be taken to assure deterioration of air quality in clean areas will not occur. It is not yet certain whether this project would have to undergo the review procedures associated with the non-attainment or PSD (Prevention of Significant Deterioration), provisions of this Act.

It is anticipated that many of the questions surrounding applicability of the Act to this project will be resolved shortly.

It is expected that most issues of concern to this office would be addressed during the design stage. This would include issues such as air quality monitoring requirements, stack testing, modeling, submittal for approval of specific plans and specifications and possibly subjects such as growth analysis and emission offsets.

As I have stated in the past, this office supports the purpose of this project and will continue to provide information and guidance in air quality matters.

Yours truly,

A handwritten signature in cursive script, appearing to read "Edmond G. Benoit".

Edmond G. Benoit
Chief, Air Quality Control Section

EGB:mlk
cc: Harry Schwartz

APPENDIX 2B

Present Retail Electricity Rate and Standby Terms

New England Power Service

New England Power Service Company
20 Turnpike Road
Westborough, Massachusetts 01581
Tel. (617) 366-9011

January 25, 1978

Dr. Robert L. Goble
Physics Department
Clark University
950 Main Street
Worcester, MA 01611

Subject: Clark-DOE, Demonstration of a Grid-Connected Integrated
Community Energy System

Dear Dr. Goble:

In order to comply with the Department of Energy's request, as stated in its letter of December 15, 1977, I am enclosing herewith a preliminary draft of a Purchase and Sale Agreement for the interchange of electric energy between Massachusetts Electric Company and Clark University. The draft has not been reviewed by our Legal Department at this time. Therefore, in providing it to you, we intend only to indicate the type of provisions which we would expect to include in a contractual agreement between us. Out of necessity, these provisions are subject to change. Further, it should be understood that it may be necessary to include additional provisions in any contract between us. As soon as our attorneys have completed their review, we will forward to you a copy of the Company's final proposed form of agreement for your review.

Further, you are well aware of our efforts and attempts to formulate a Cogeneration Policy and Rate; but, at this time, we are not ready to file a cogeneration document with the Massachusetts Department of Public Utilities (M.D.P.U.). When our Cogeneration Policy and Rate have been finalized, accepted and approved by M.D.P.U., then the Rate will be made available to Clark as an alternate purchase price schedule to that presented in paragraph 6 (b) of the Agreement.

I must remind you that any proposed agreement that Massachusetts Electric Company would offer to Clark must be approved by M.D.P.U. before the agreement may be executed. If you have any questions, please contact me.

Very truly yours,



Ronald W. Plutnicki, P.E.
Consumer Services Consultant

BETWEEN

CLARK UNIVERSITY AND MASSACHUSETTS ELECTRIC COMPANY

AGREEMENT dated as of _____ and made by Clark University (Clark), a Massachusetts university of higher education and Massachusetts Electric Company (Masselec) a Massachusetts Corporation engaged in the retail sale of electricity.

1. Scope of Agreement

Clark will generate electricity as a by-product of its cogeneration plant. The majority of this electric energy will be used to satisfy Clark's requirements. Since the cogeneration plant has been designed with an electrical output greater than Clark's present and projected requirements, Clark seeks to sell its excess electric energy from the cogeneration plant.

Masselec is willing to absorb (in whatever amount) the excess electricity so generated, at the cogeneration plant, into its system whenever this generation is available. Masselec is also willing to provide backup service, (in an amount to be identified) whenever the cogeneration plant cannot meet Clark's electrical requirements.

The parties of this agreement hereby set down the terms whereunder they will provide for an interchange of electric energy.

2. Sale of Electricity

(a) Clark agrees to sell and Masselec agrees to buy all excess electricity (over and above Clark's requirements) that is generated at Clark's cogeneration plant at the times and under the terms of paragraph 4 of this agreement.

Masselec agrees to sell and Clark agrees to buy all electricity needed to meet Clark's electrical requirements when the cogeneration

plant is unable to meet Clark's requirements, under the terms of paragraph 4 of this agreement.

3. Effective Date and Term

The term of this contract shall commence upon the Commercial Operation date of Clark's cogeneration plant and the interconnection with Masselec's system, in such a manner as will allow delivery to be made to Masselec, and shall continue until terminated by either party giving to the other six (6) months written notice specifying the date of termination, such date of termination to be not earlier than twenty (20) years after the aforesaid date of commencement.

4. Terms of Sale

Clark will operate its cogeneration system so as to meet the thermal and electrical requirements of the university complex. Clark's excess electricity may be delivered to Masselec at any time each day, and such electricity will be purchased by Masselec at the price stipulated in paragraph 6 (a) herein.

Masselec will provide Clark with electric service during those times when the Clark cogeneration plant cannot meet the university's total requirements, at a price stipulated in paragraph 6 (b) herein.

Clark will arrange its maintenance program to preclude the possibility of the cogeneration system being out of service during the following months of the year: December, January, February, June, July and August.

5. Delivery

Electricity shall be delivered at the interconnection point between the parties' facilities in the form of three phase, sixty hertz, alternating current at approximately 13,800 volts. The voltage shall not vary more than 10% from said voltage, momentary fluctuations excepted.

6. Price and Billing

(a) Recognizing that the term of this contract is for a term of twenty (20) years or more, Masselec is agreeable to a variable rate for such a term. A definable cost that will serve as a base for Masselec purchases from Clark is the cost of fuel as set out in the New England Power Company (NEP) FERC Electric Tariff. The payment will be defined by Masselec on a monthly basis as follows:

(Weekdays, 7:00 a.m. to 11:00 p.m.) \$/kwh = A x 1.30

(Weekdays, 11:00 p.m. to 7:00 a.m.) \$/kwh = A x 1.06

(Weekends and Holidays, 24 hours) \$/kwh = A x 1.06

A = the average New England Power Company (NEP) fuel costs for the current operating month.

1.30 & 1.06 = multipliers used to convert NEP's average fuel costs to incremental fuel costs. These multipliers are subject to modifications, to reflect changes in the relationship between the average fuel cost and the incremental fuel cost.

(b) Masselec will stand ready to sell electricity to Clark during those times when the cogeneration plant cannot provide the total university requirements. The pricing of such service will be the sum of the following:

Distribution Capacity Charge

\$2.00 per month per kilowatt of Distribution Capacity contracted for as a maximum service taking by Clark.

Energy Charge

All energy purchases will be billed in accordance with Masselec's General Rate C-22 as filed from time to time with the Massachusetts Department of Public Utilities (M.D.P.U.), presently M.D.P.U. No. 374 or any supercession

or modification thereto, except that the minimum charge will not apply to this agreement.

Determination of Distribution Capacity

The Distribution Capacity made available to Clark will be determined by the capability contracted for as a maximum service taking and for this agreement shall be fifteen hundred (1500) kilowatts.

If at any time the Demand as measured in kilowatts (kw) exceeds the capability contracted for, that demand will become the contracted for capability.

High Voltage Metering Adjustment

Masselec reserves the right to determine the metering installation. Where service is metered at Masselec's supply line voltage, thereby saving Masselec transformer losses, before determining the number of kilowatts of demand and kilowatthours to be billed under the preceding provisions, there shall be deducted from the meter registrations of kilowatts and kilowatthours for the month in question an amount, respectively, of one percent (1%) of such registrations.

- (c) If in the future Masselec files with the M.D.P.U. a cogeneration policy and cogeneration rate, and if said policy and rate are approved by the M.D.P.U.; then said cogeneration policy and cogeneration rate will be made available to Clark as an alternate purchase price schedule to that presented in paragraph 6 (b) of this agreement.

7. Rate of Taking, Transformer Capacity

For the period from the date of commercial operation of Clark's Cogeneration Plant until such time as additional capacity is needed by Clark, and Masselec shall have given written consent, upon timely notice, to an increased level,

Clark may take hereunder electricity (when the Cogeneration Plant cannot meet the University's needs) at any rate not exceeding sixteen hundred (1600) Kilovolt-amperes, and for the said period the transformer capacity will be deemed to be 1600 Kilovolt-amperes.

8. Parallel Operation

Clark may operate its electrical generating equipment in parallel with Masselec's system provided that:

- (a) Clark own, install, and maintain protective devices and apparatus that Masselec deems acceptable, and
- (b) that Clark save and hold harmless Masselec from all claims for damage to Clark's equipment or injury to Clark's employees or others on Clark's property arising out of or referable to such parallel operation.

9. Interconnection Responsibilities

The responsibilities of each party to this Contractual Agreement which will allow for the interchange of electric energy are described as follows:

- (a) Clark will install the necessary protective devices in its substation in accordance with design drawing No. _____. Clark will do all synchronizing of its electric generator.
- (b) Masselec will do all work in its substation, at Clark's expense, that will insure the interchange of electric energy, in accordance with design drawing No. _____. Masselec will install the necessary metering equipment in Clark's substation and at Clark's expense, in accordance with design drawing No. _____ for electricity registration, for billing purposes and priced according to Paragraph 6 of this agreement, for Masselec's purchase and sale of electricity.

(c) Masselec will supply relay settings. Masselec must either set and test the relays, or witness the setting and testing, both at Clark's expense.

10. Metering

All electricity shall be measured in the form of three phase, sixty hertz alternating current of approximately 13,800 volts.

11. Access to Facilities and Records

Representatives of the parties to this Agreement shall at all reasonable times have access to the facilities and daily/monthly information sheets of the other for the purpose of making inspections and obtaining information reasonably required in connection with this Agreement.

12. Modern Apparatus and Practice

Each party to this Agreement shall use modern standard commercial apparatus and shall exercise the necessary skill and diligence required to secure satisfactory operation in accordance with the best modern practice in order that the best service practicable can be maintained.

13. Regulations and Franchises

This agreement and all rights, obligations and performances of the parties hereunder are subject to (a) all present and future applicable state and federal law and to all duly promulgated orders and other duly authorized action of governmental authority having jurisdiction in the premises; and (b) the retention by the parties of the rights of way, franchises, locations, permits and other rights necessary for the performance of this Agreement.

14. M.D.P.U. Approval

-46-

Prices to be paid for electricity by Masselec hereunder, along with Masselec's filed Terms and Conditions, Provisions, and Rates, are subject to review and determination by M.D.P.U. in any proceeding brought under Sections 93 or 94 of Chapter 164 of the General Laws, as amended, to the extent provided for and in accordance with the terms of Section 94A of said Chapter.

15. Assignment

This Contractual Agreement shall be binding upon and shall inure to the benefit of, and may be performed by, the successors and assigns of the parties, except that no assignment, pledge or other transfer of this Contractual Agreement by either party, shall operate to release the assignor, pledgor or transferee of any of its obligations under this Agreement unless consent to the release is given in writing by the other party, or, if the other party has heretofore assigned, pledged or otherwise transferred its interest in this Agreement, by the other party's assignee, pledgee or transferee.

16. Integration

This document contains the entire agreement and understanding between the parties as to the subject matter of this Agreement, and merges and supercedes all prior agreements, commitments, representations, writings, and discussions between them.

Neither this Agreement nor any term or provisions hereof, excluding the multipliers presented in paragraph 6 (a), may be changed, modified, amended, waived, discharged or terminated orally, but only by an instrument in writing signed by an officer of the party against which the enforcement of the change, modification, amendment, waiver or discharge, or termination is sought.

17. Severability

Should any provision of this Agreement be held invalid, such provisions shall be considered severable and such invalidity shall not affect the remainder of the provisions herein.

18. Applicable Law

This Agreement is made in and shall be construed and interpreted in accordance with the laws of the Commonwealth of Massachusetts.

[THIS PRELIMINARY DRAFT CONTRACT IS SUBJECT TO CHANGE UPON LEGAL REVIEW]

MASSACHUSETTS ELECTRIC COMPANY

BY _____

TITLE _____

CLARK UNIVERSITY

BY _____

TITLE _____

MASSACHUSETTS ELECTRIC COMPANY

General Rate C-22
M.D.P.U. No. 374

Purchased Power Cost Adjustment No. 6

Effective February 1, 1977

Monthly Charge as Adjusted

\$2.00	First	20	KWH or less per month
6.672¢ per KWH	Next	80	KWH per month
6.072¢ per KWH	Next	200	" " "
4.962¢ per KWH	Next	1700	" " "
3.772¢ per KWH	Xcs of	2000	" " "

Minimum Charge

Zero Use = \$1.87

Use 1-20 KWH = \$2.00

However, if the KVA transformer capacity needed to serve a customer exceeds 25 KVA, the minimum charge will be increased by \$1.75 for each KVA in excess of 25 KVA.

Other Rate Clauses apply as usual.

MASSACHUSETTS ELECTRIC
COMPANY

GENERAL RATE C-22

AVAILABILITY

Service under this rate is available for all purposes.

No service will be furnished hereunder to a Customer for resale in whole or in part within the territory of the Company, except to a Customer who was engaged in reselling electricity furnished by the Company on April 21, 1958 who may continue to resell, but only under the same circumstances or conditions, in the same location and to the same extent as such Customer was reselling on said date.

MONTHLY CHARGE

- \$1.87 for the first 20 kilowatt-hours or less of electricity delivered each month,
- 6.016 cents per kilowatt-hour for the next 80 kilowatt-hours,
- 5.416 cents per kilowatt-hour for the next 200 kilowatt-hours,
- 4.306 cents per kilowatt-hour for the next 1700 kilowatt-hours,
- 3.116 cents per kilowatt-hour for the excess over 2000 kilowatt-hours.

PURCHASED POWER COST ADJUSTMENT

The prices under this rate as set forth under "Monthly Charge" may be adjusted from time to time in the manner provided in the Company's Purchased Power Cost Adjustment Provisions to reflect changes occurring on or after January 1, 1971 in the Primary Service for Resale Rate of the Company's supplier, New England Power Company.

ADJUSTMENT FOR COST OF FUEL

The amount determined under the preceding provisions shall be adjusted in accordance with the Company's Standard Fuel Clause as from time to time effective in accordance with law.

**MASSACHUSETTS ELECTRIC
COMPANY**

GENERAL RATE C-22

MINIMUM CHARGE

\$1.87 per month.

However, if the KVA transformer capacity needed to serve a customer exceeds 25 KVA, the minimum charge will be increased by \$1.75 for each KVA in excess of 25 KVA.

BIMONTHLY BILLING

The Company reserves the right to read meters and render bills on a bimonthly basis. When bills are rendered bimonthly, the charge for the initial block, the kilowatt-hours stated in each block and the Minimum Charge shall be multiplied by two.

TERMS AND CONDITIONS

The Company's Terms and Conditions in effect from time to time, where not inconsistent with any specific provisions hereof, are a part of this rate.

Effective December 8, 1976.

Appendix 2C

Draft

ENVIRONMENTAL EVALUATION REPORT

Table of Contents:

1. Summary of Phase II Activities
2. Preliminary Environmental Impact Assessment
3. Massachusetts Environmental Assessment Form
4. Individuals and Offices Consulted

November, 1977

1. SUMMARY OF PHASE II ACTIVITIES

Changes in the assessment of environmental impacts were caused by the change of equipment from an engine burning #2 distilled oil to one operating on #6 residual. This new engine and its appurtenances, such as oil treatment equipment, water treatment equipment and auxiliary tanks, changed the configuration of the project, its operational characteristics, and its pollutant emissions. Major changes from the environmental impact assessment prepared during Phase I are a reduction in the increase of NO_x emissions and particulates and an increase in SO₂ and HC_x emission. In addition, a liquid effluent is now present. The following sections, organized in the same way as was the Phase I report, reflect these changes. Discussions with the regulatory agencies affected do not, however, raise any new problems due to the changes in the installation.

2. PRELIMINARY

Environmental Impact Assessment

November, 1977

Environmental Impact Assessment (E.I.A.) of the proposed contract EC-77-C-02-4211, "Demonstration of a Grid-Connected Integrated Community Energy System" at Clark University, Worcester, Massachusetts.

Submitted in accordance with the National Environmental Policy Act of 1969 and according to the guidelines promulgated by ERDA on December 8, 1976, and published in the Federal Register, Volume 42, Number 17, January 26, 1977, pp. 4826-4833.

Submitted to: The Energy Research and Development Administration
Chicago Operations Office
9800 South Cass Avenue
Argonne, Illinois 60439

Contents

- I. Introduction
- II. Description of Proposed Action
- III. Description of Existing Environment
- IV. Potential Environmental Impacts
 - A. Positive
 - B. Negative
 - 1. Construction -- short term
 - 2. Operation -- long term
- V. Coordination with federal, state, regional and local plans.
- VI. Description of Alternatives
- VII. Conclusion

Submitted by: The Environmental Impact Assessment Group
Professor Harry Schwarz, Coordinator
Clark University
950 Main Street

I. Introduction

The more efficient use of energy is an urgent national challenge. Nowhere is this need greater than in New England where the energy prices and reliance on imported energy supplies are the highest in the country. In response to this situation, Clark University is proposing that it decrease its energy use through the installation of a co-generation system. This system would involve the generation of electricity on campus by a diesel generator and the utilization of the engine's "waste heat" in the University's steam heating system. By utilizing the heat that is normally lost in the generation process, the energy efficiency of the co-generating system will be approximately 25% higher than at present.

Similar co-generation systems have a proven record of safety, technologic success, energy conservation, and economic savings in many European countries.

II. Description of the Proposed Action

The cogeneration system would involve the installation of a Sulzer 8 cylinder, ASL-30 diesel rated at 1494 Bhp at 900 RPM. The diesel would generate 1405 kilowatts of electricity and provide 3.67×10^6 Btu/hr of energy to the University heating plant. When in operation the system will meet nearly all of the University's electrical demand. The system will be integrated with Massachusetts Electric Company. The utility has agreed to purchase electricity generated in excess of the University's demand and to sell electricity to the University when the

generator is not in operation or otherwise unable to fulfill the University's demand. The thermal load of the University that exceeds the diesel's output will be provided by the present boiler system.

The positive environmental impacts include: (a) the conservation of scarce resources, (b) maintenance of the financial strength of Clark University, (c) the creation of an energy conservation demonstration facility in Massachusetts, (d) enhancement of Clark University's programs and reputation in energy management, (e) additional experience in the design, construction and operation of co-generation facilities by the technical participants, (f) the expenditure of approximately one million dollars in some of the most economically depressed regions of the country, (g) a small reduction in the emission of some air pollutants in the New England region, (h) reduction in the negative environmental impacts involved with the extraction, processing and transport of fuels, and (i) decreasing the negative economic impacts that result from New England's dependence on expensive imported oil, (j) assisting in a more positive national balance of payments, and (k) reducing the political vulnerability that results from the nation's lack of energy self-sufficiency.

The anticipated negative environmental impacts may be associated with the construction (approximately 6 months) or the operations phase. The former include (a) additional traffic on the campus, (b) the aesthetic impact (audio and visual) of the construction operation, (c) emission of particulate matter (dust) in the local area, Anticipated negative impacts of the

operational phase include: (a) an increased emission of some air pollutants at Clark University, (b) the discharge of a limited amount of water contaminated by oil treatment residues, (c) the noise and vibration of the diesel engine and generator, (d) the increased presence of oil delivery trucks, (e) the visual and physical impact of the building that will house the diesel and generator, (f) the audio and visual impact of the system's small cooling tower, and (g) an element of unknown risk that accompanies the alteration of an existing system. All of these impacts, including an evaluation of the significance of each, are discussed in detail in Section IV.

III. Description of the Existing Environment

For the purpose of evaluating the system's environmental impact, the description of the existing environment has been divided into five categories: (a) the present energy system, (b) the building in which the present energy system is located, (c) the University campus, (d) the surrounding residential community, and (e) metropolitan Worcester.

(a) The Present Energy System. The central heating plant is located in the northwest quadrant of the basement of Jonas Clark Hall (see Fig. 2C-EIA-1). There are three boilers--two rated at 21×10^6 Btu per hour and one rated at 29×10^6 Btu per hour. The peak thermal demand of the University can be met by one of the small and the larger boiler. The steam and hot water are piped through a network of underground tunnels to the other buildings on campus (see Fig. 2C-EIA-2). The boilers can be adapted to burn either residual (#6) or distillate (#2) oil, or natural gas. Exhaust from the boilers is vented through a 95 foot

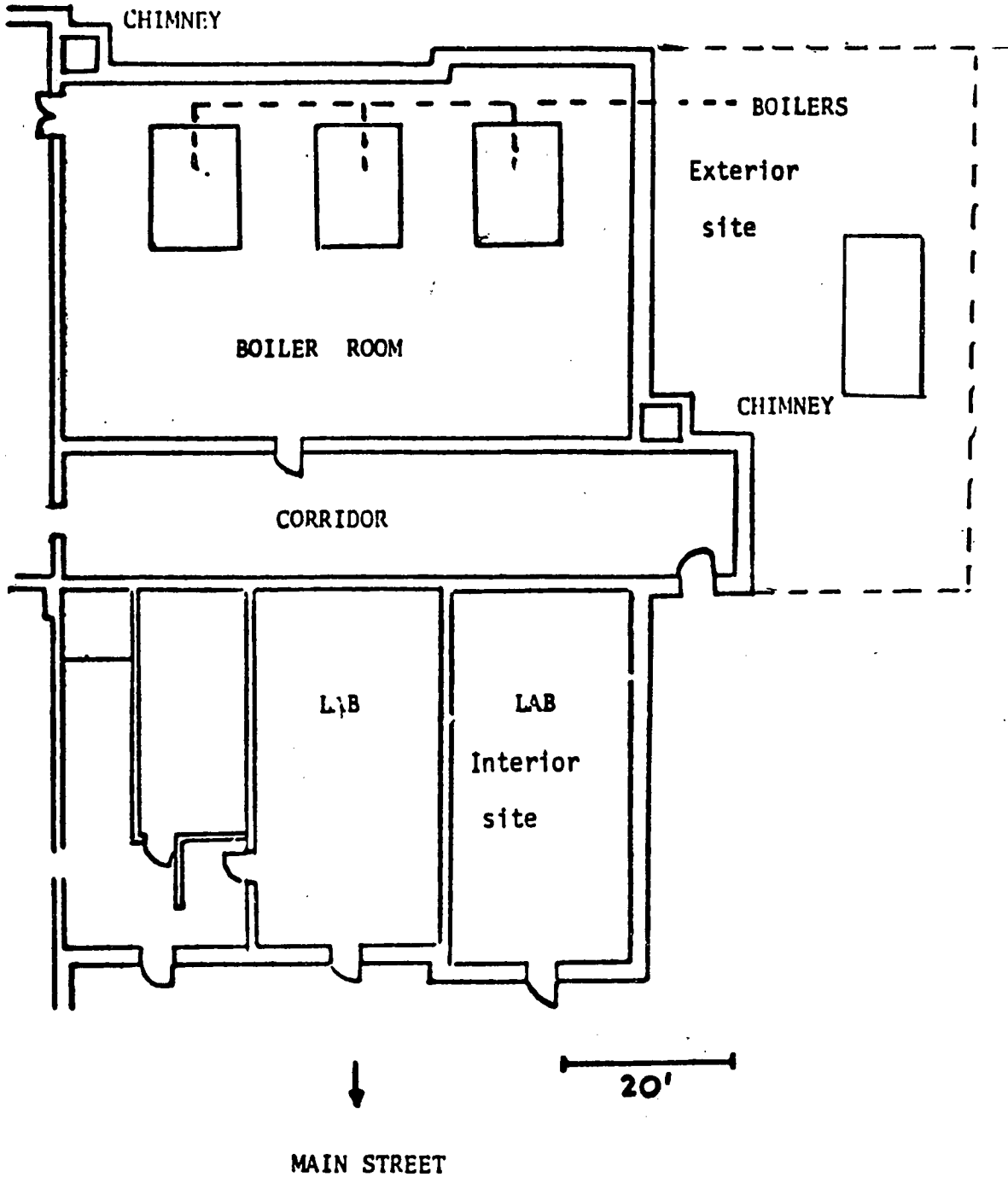
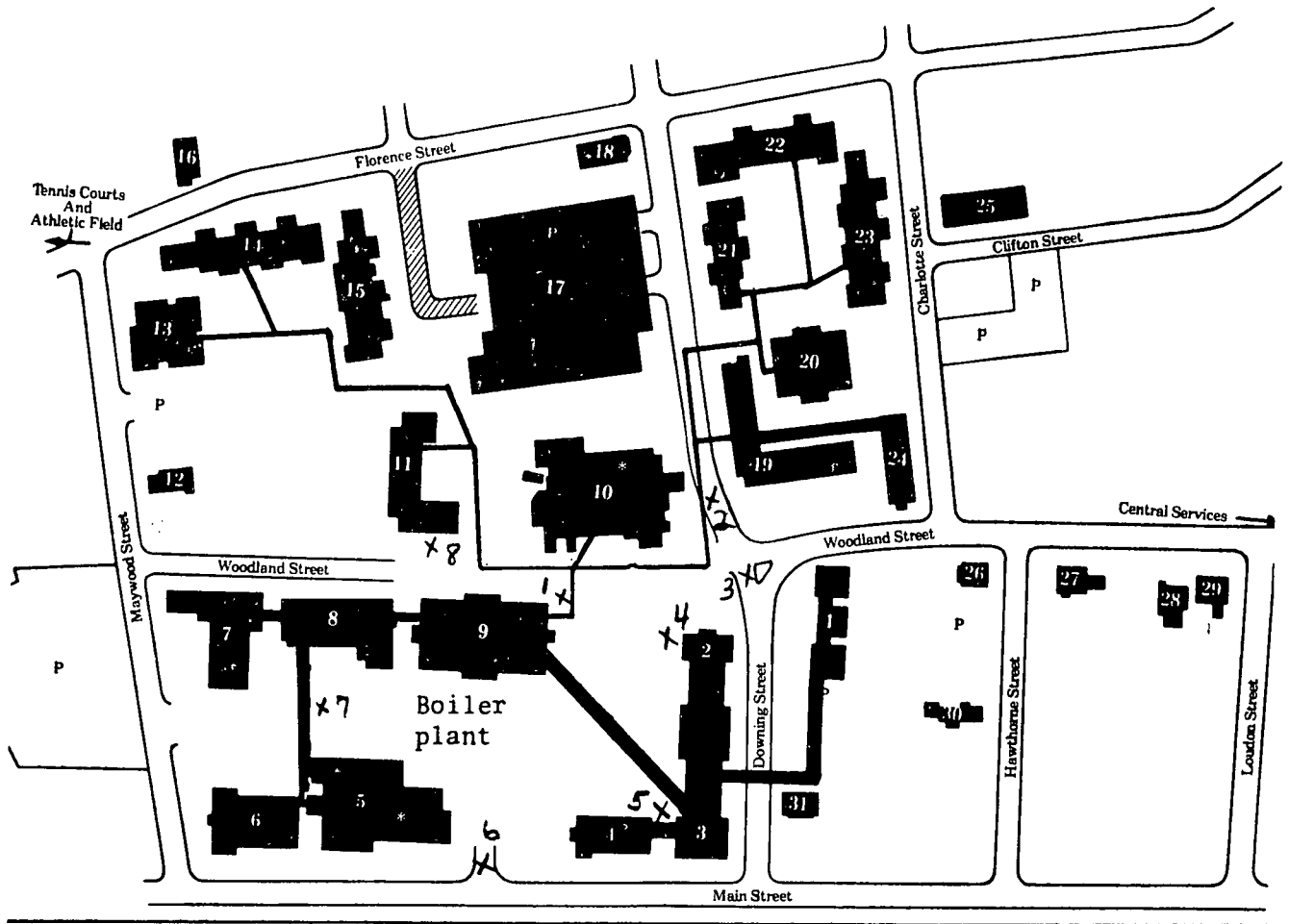

Figure 2C-EIA-1. Plan of the East wing of Jonas Clark Hall, showing the present boiler plant and the space for the possible grid-connected ICES



- 125 psig steam lines
- 40 psig steam lines
- 15 psig steam lines

Figure 2C-EIA-2. Steam distribution system at Clark University. Steam lines in all cases include both steam supply and condensate return.

- | | |
|--------------------------------------|--|
| 1. Downing Administration Center | 18. General Store/Birth Control Center |
| 2. Atwood Hall | 19. Wright Hall |
| 3. Academic Center | 20. Little Center for the Visual and Performing Arts |
| 4. Geography Building | 21. Dodd Hall |
| 5. Jefferson Hall | 22. Johnson Hall |
| 6. Alumni Gymnasium | 23. Sanford Hall |
| 7. Science (Bio-Physics) Building | 24. Estabrook Hall |
| 8. Jeppson Laboratory | 25. Physical Plant |
| 9. Jonas Clark Hall | 26. Alumni House |
| 10. Robert Hutchings Goddard Library | 27. English House |
| 11. Bullock Hall | 28. Carriage House |
| 12. Potter Laboratory | 29. Department of Management |
| 13. Dana Commons | 30. Nursery School/Computer Lounge |
| 14. Dana Dormitory | 31. Downing Residence Restrooms and Public Telephone |
| 15. Hughes Hall | P Parking Area |
| 16. Florence Residence | |
| 17. Student Activities Center | |

stack mounted on the north side of the building. The oil is delivered on campus by tanker truck and stored underground in two 20,000 gallon tanks. The boiler operations are inspected periodically and meet all local, state, and federal regulations. They are operated by specially licensed personnel.

Electric power is supplied by Massachusetts Electric Company, a member of the New England Electric System. The electricity is provided by a single, 13,800 volt utility line. It is connected to University owned transformers located on the North side of Jonas Clark Hall near the heating plant. Electricity is distributed from this point throughout the campus.

(b) Jonas Clark Hall. Jonas Clark Hall is located in the center of the campus (see Fig. EIA-2). It was built in 1887, is a brick construction, has four floors and contains 84,289 gross square footage. As mentioned previously, the present boiler system is located in the northwest corner of the building's basement. An old gym, craftshop, gameroom, three small laboratories, and a lavatory are also located in the basement level. The three upper floors are devoted to classrooms, faculty offices, and the offices of the College of Professional and Continuing Education.

Although the sound levels inside the boiler room are high (95-85 decibels), the building's thick brick walls, the boiler room's brick ceiling, and sound proofing reduce the sound levels immediately outside the boiler room to the ambient level. (See Table EIA-1 for specific decibel readings.) The sound reduction is important since the building is set in the center of the campus.

Table 2C-EIA-1

Noise levels at Clark University^a

Location	Noise level (dB)
Main Street, heavy trucks	95
Inside present boiler plant	95
Main Street, normal traffic	75
Outside window of present boiler room	70
Residential street at back of campus	70
Inside Clark computer center	68
Inside room with people talking	65
Street enclosed by campus, no cars	55
Park across Main Street, opposite Clark	55
Dormitory quadrangle	52

a. Data measured by students in the Program on Science, Technology and Society with a portable dB meter..

(c) The Campus. The University owns 35 acres of land. The area covered by the main buildings and served by the central steam distribution system is 15 acres. The University owns 46 buildings, of which 21 are considered "major." There is approximately 1,000,000 gross square feet of building space. (Fig. 2C-EIA-2 indicates the layout of the central campus.)

The architectural styles of the buildings vary considerably, representing a history of the changing perceptions of the "academic style" held by architects and administrators. The result is a combination of modified gothic, New England mill, high efficiency barracks, and modern irregular. A 12 person aesthetics committee advises on architectural changes that might detract from or intrude upon this architectural melange.

Clark is a small university with about 2,000 undergraduates, 250 graduate students, 280 staff members and 140 full-time faculty members. This results in a campus week day population of 2,600 and an evening/weekend population of 1,200 when the University is in session. Clark has not escaped the recent economic pressures familiar to private universities. Tuition raises have been a regular, unavoidable feature as have staff reductions and very modest salary increases for the remaining staff and faculty. In the 10 year period from 1965 to 1975, the University's total energy costs rose from \$81,000 to \$560,000. The University's energy costs in 1976 were \$389,938, which indicates that Clark's efforts to respond to these pressures have been determined and effective. Past operating deficits have been eliminated, active cost cutting measures have been under-

taken, a major fund raising campaign is underway, energy conservation efforts have reduced thermal demand by 41% between 1972 and 1976 and electrical demand by 41% between 1970 and 1976, and imaginative programs have been instituted to both attract superior students and insure the financial stability of the University. The proposed cogeneration system is, of course, one such project. (See Fig. 2C-EIA-3.)

The sound level on the campus varies considerably with time of day and location. Fig. 2C-EIA-2 shows locations on the campus at which sound measurements were made to establish baseline data. Table EIA-2 presents average and lowest readings taken over several days.

Table 2C-EIA-2

Baseline Sound Data

Level	Average Sound Levels A curve				Time	Minimum Sound Levels A curve		Time Measured
	8am	11am	5pm	2am		Location	db	
1	65db	67	65	60		1	60	2 am
2	60	54	54	42		2	42	2 am
3	62	60	58	46		3	46	2 am
4	58	60	58	51		4	51	2 am
5	53	52	50	44		5	44	2 am
6	68	70	70	49		6	49	2 am
7	55	55	50	46		7	46	2 am
8	57	56	56	50		8	50	2 am

(d) The Community. The University's campus is situated in a residential neighborhood 1.2 miles south of the city center (see Fig. EIA-2). The campus is set in a high density landscape

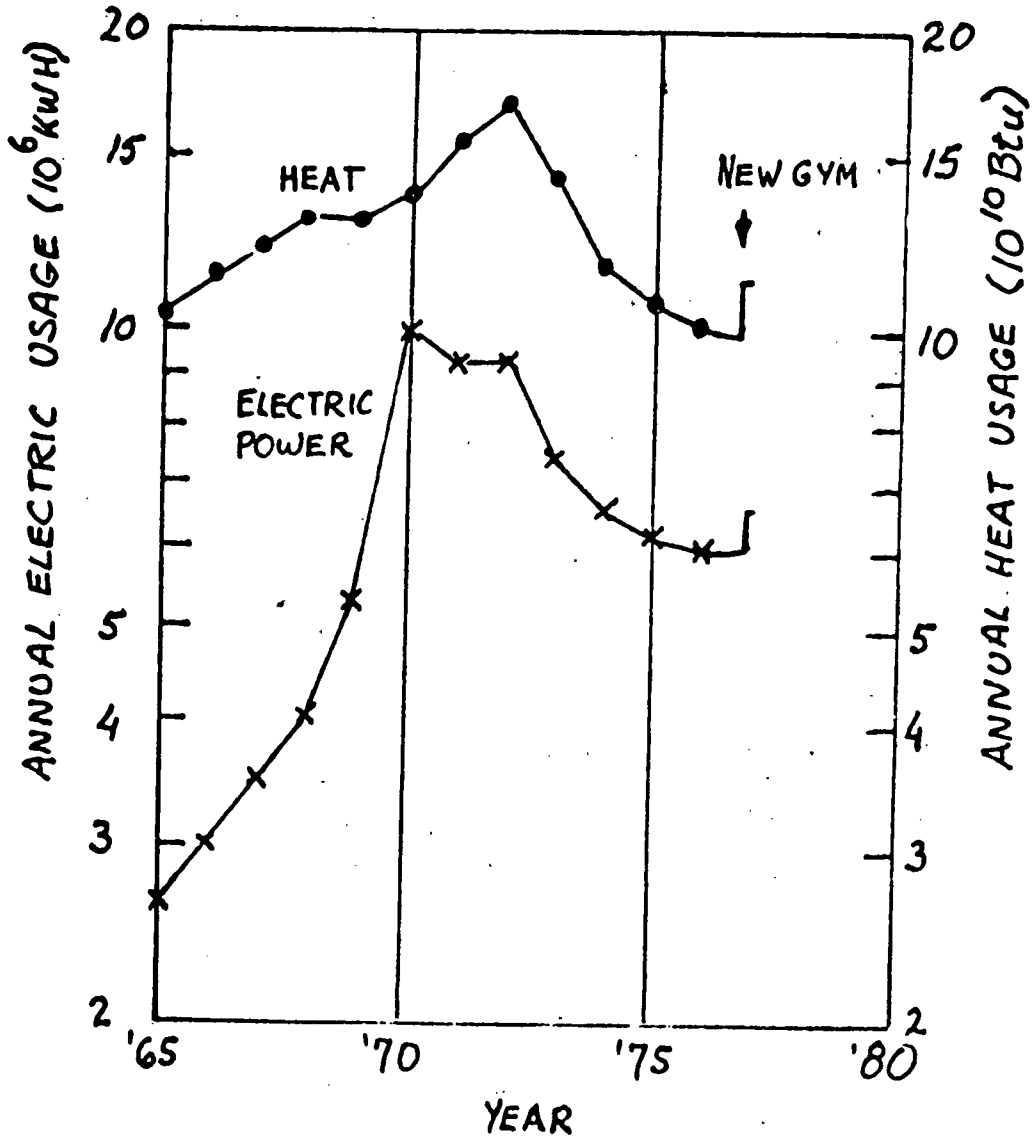

Figure 2C-EIA-3

Illustration of energy consumption at Clark since 1970.

typical of urban New England. On three sides the neighborhood consists of two and three story houses (triple deckers) located on small, narrow lots. Some of these structures are single family residences, but most contain several rental units. The median family income of the area was \$8,819 in 1975. Main Street lies to the east of the campus. It is a major artery and truck route. On it are located a number of small service oriented businesses, churches, and public service organizations. The residential neighborhood resumes to the east of the artery (see Fig. EIA-2).

The University's relations with the surrounding community are generally positive. The primary issues of community-university conflict are all related, but for clarity are presented separately here. (1) There has been a serious lack of student parking on campus. Although the university added 140 new parking spaces in 1976 and will add 200 spaces in 1977, the problem is still not entirely resolved. (2) Students rent many of the apartments in the area surrounding the campus. Some residents in the community feel that this movement has decreased the community's viability. (3) The issue that has caused the most stress is the University's purchase of adjacent, residential property for expansion. Similar to student apartment renting, the same residents feel that this decreases the number of school age children in the community and jeopardizes the continued operation of the community elementary school on Downing St. Since the University plans no major future expansion, this dispute should not be an issue in the future. A significant aspect

of the proposed ICES installation is that it will not affect any of these areas of University-Community conflict.

(e) Metropolitan Worcester. The city of Worcester has a population of approximately 170,000 and more than 6 million people live within 50 miles of the city. Although Worcester is the second largest city in New England, it is best described as an old, medium-sized, industrial city. Similar to many cities in the Northeast, the post World War II era has brought changes that have stressed the economic and social fabric of the city. The population has declined as the more affluent moved to the suburbs, textile and related industries have closed, the tax rate has continuously increased, urban renewal programs have met with only partial success, abandoned buildings degrade older neighborhoods, etc. Recently the city's response to these problems has been more effective and actually reversed many of the negative trends. The city center is being revitalized, and the exodus of people and industry has slowed, newer service industries are expanding.

Clark is one of eleven colleges and universities of the Worcester Consortium of Higher Education. These institutions combine to become one of the largest employers in the city. For this and other reasons, the well-being of the region's colleges and universities is critically important to the resurgence mentioned above.

Worcester, like the rest of the Northeast, suffers from extremely high energy costs. These costs exceed those in any

other part of the country. Most industries and many individuals have instituted conservation measures and reduced their energy consumption significantly. But further conservation measures, such as Clark's ICES proposal, will be necessary if the city and region are to remain economically competitive in the future.

The most persistent, specific "environmental" problem in Worcester is the high particulate content of its air. Worcester is presently a "Non-Attainment" area for particulate matter, consistently violating the state air quality standards for particulate matter.

A review of the quarterly air pollution measurements at Clark, contained in EIA Table 2, indicates that the particulate levels exceed the standards by a maximum of 25% over the past 5 years.

Table 2C-EIA-3

Quarterly air pollution at Clark^a

Year	Total suspended particulates ^b (ugm/m ³)				SO ₂ ^c (ppb)				NO ₂ ^d (ppb)			
	1	2	3	4	1	2	3	4	1	2	3	4
1971			62	68			9	14			78	71
1972	76	62	50	46	13	6	4	14	42	34	42	39
1973	76	44	43	55	15	3	1	6	29	47	51	24
1974	68	62	40	51	12	2	1	13	30	25	21	32
1975	63	58	32	40	16	4	4	12	30	24	19	36
1976	57				11					29		

a. Data supplied by Edward Benoit, District Chief, Central Massachusetts Air Quality Control District. The numbers quoted are quarterly mean values.

b. Federal and Massachusetts Air Quality Standards for Total Suspended Particulates are.

	<u>Primary</u>	<u>Secondary</u> (in ugm/m ³)
Year	75	60
Day	260	150

c. SO₂ levels at Clark are less than 1/3 of typical values encountered in major cities.

d. NO₂ levels at Clark are 1/3 to 1.2 of typical values encountered in major cities.

The high particulate content of the air is thought to be a result of the topography of the city. The city is extremely hilly and this results in the use of excessive amounts of road sand in winter. In addition, the city is located in a basin

which discourages dispersion of particulates and encourages the development of temperature inversions.

IV. Potential Environmental Impacts

A. Positive. The positive impacts that were listed in section II will be discussed in detail in this section.

The conservation of scarce resources is one of the primary objectives of the installation. Measures that result in significant reductions in national oil consumption without serious economic or environmental disruption must be viewed as positive contributions to the human and physical environment. The significance of these actions is even higher when it occurs in regions which have no indigenous sources of fossil fuels. The ICES plant will reduce Clark University's total energy consumption from 213.3×10^9 Btu to 171.5×10^9 Btu per year or by approximately 20%. These figures correspond to a reduction of 284,900 gallons of oil consumed per year to meet the University's electrical and thermal needs. The total energy savings are even greater in terms of net energy savings due to energy saved by not needing to extract, transport, and refine the 284,900 gallons of oil per year.

In the context of fuel conservation, the ICES installation should be viewed as part of the University's overall commitment to reduce its energy consumption. This commitment has been active and effective. Since 1970, the University has managed to reduce its thermal energy demand by 41% and its electrical demand by 41%. These savings have been achieved through the

efforts of students, staff and faculty, energy use studies, the improved efficiency of end use equipment, an IBM System load dropping computer and improved thermostatic and electrical controls.

The maintenance of the financial strength of the University is a significant attribute of the ICES proposal. The cost of fulfilling the energy requirements at Clark in 1975 was \$560,000. This amounts to approximately 20% of the amount spent on faculty salaries at the University. Reducing these figures by 20% would be a very positive economic impact. Since other conservation measures have already been successfully implemented, the ICES installation is the only practical means of further reducing the University's energy cost burden.

Clark is a private university and tuition costs have increased dramatically over the last decade. Already many individuals are excluded from attending for financial reasons. The savings from the ICES will help to reduce further tuition increases, maintain the University's ability to compete for the most qualified students, and hopefully, renew opportunities that were previously closed due to high tuition rates. It should be pointed out that presently Clark benefits from a declining block rate pricing structure. The projected savings of the ICES will be larger if these rates move towards a more uniform rate structure.

The creation of an energy conservation demonstration facility in Massachusetts would be a positive contribution of the ICES installation. Establishment of a co-generation demon-

stration plant, of a size and scale appropriate to many industrial, commercial, institutional, and public facilities would be an important asset to the region. The effect that the ICES would have as a demonstration site encouraging similar conservation efforts by others is the primary reason the project has received the attention and support of the Commonwealth's Governor and Energy Policy Office.

Three factors insure that the ICES installation will provide an effective demonstration facility. First, Worcester is unusually accessible to the rest of New England. The city's motto "The Heart of New England" implies and its location on I-90 and I-290, functioning train station and airport insure ease of access to the facility. Over 50% of the region's population lives within 50 miles of the Clark Campus. Secondly, the University has established an impressive record in monitoring and recording its energy use patterns: The Science, Technology and Society Program at Clark has devoted three issues of its journal to energy use at the University. Finally, the demonstration facility would include information on the University's other conservation efforts which, as noted above, have been extremely effective.

The ICES will enhance Clark University's programs and reputation in energy management. Clark has become a center for a considerable amount of research in the energy field. This research has ranged from projects in methane gas digestion, solar energy, wind energy, conservation technologies to funded research in the societal risk of nuclear power, the electric utility-solar energy interface, and methane gas generation from waste treatment

plants. Students and faculty in two departments, Geography and Physics, and two Programs, Environmental Affairs and Science, Technology, and Society, have been particularly active in the field of energy research. A co-generation facility on campus would provide numerous new research opportunities. Installation of an ICES system at the University would enhance the University's position in the energy management field.

The ICES installation will result in additional experience in the design, construction and operation of co-generation facilities by the technical participants. Although the concept of co-generation has been understood for many years and many such facilities exist in Europe, there is relatively little technical experience with them in the United States. Installation of the ICES plant at Clark should be considered an important addition to this experience. This experience is an important addition to the technical resources that the nation will need to respond to the energy crisis. Since this installation will play a significant role in moving co-generation from theoretical concept to political reality, the increase in the knowledge gained in dealing with the issues involved in each step (design, construction, and operation) is a very positive impact resulting from the ICES.

The expenditure of approximately one million dollars in some of the most economically depressed regions of the country. The ICES installation will involve the dispersal of about one million dollars in the national economy. The money will help generate jobs in the regions where unemployment has been most

persistent and severe -- New England and the Upper Mid-West. In New England many of the jobs will be in the construction field where unemployment levels have been especially high. If the Clark University ICES acts as a stimulus for other installations (as is expected), the positive effect on regional employment levels would be even more significant.

A reduction in the emission of some air pollutants will occur because the increased efficiency of the ICES will result in reducing total oil consumption by 284,900 gallons. The savings will be at the Massachusetts Electric generating stations. Assuming that the fuel not consumed is residual oil, the emission of particulate matter will be reduced by 2.7 tons/year and SO₂ emissions will be reduced by 22.9 tons/year. (See EIA Table 4.)

Reduction in the negative environmental impacts involved with the extraction, processing and transport of fuels. The 284,900 gallons of oil that is conserved by the ICES installation also contributes to the reduction of the negative effects often associated with drilling, refining and transportation of oil. This positive impact is not very significant, but it is a factor that should be considered when evaluating the decisions that may encourage or discourage the widescale use of ICES.

Decreasing the negative economic impacts that result from New England's dependency on expensive imported oil. New England's dependency on more expensive, foreign oil supplies contributes to the region's high cost of living and higher operating costs for business establishments. Electricity rates in the region are

particularly high and act to discourage the growth of industries that use large quantities of that source of energy. In addition, the region is particularly vulnerable to actions that reduce the availability of oil shipments. Installations of the ICES would reduce the region's dependence on foreign supplies and vulnerability to another embargo. As such, it would improve the economic potential of the region significantly.

Assisting in a more favorable balance of trade. Since the rapid rise in oil prices in 1973, oil imports have consistently been the most expensive item imported by the United States. With oil imports now exceeding domestic production, the ability of the nation to maintain a surplus balance of trade will be severely tested. Installation of the ICES system will decrease the outflow of money. Presently, approximately 75% of New England's residual oil is from foreign sources charging \$12.00 a barrel. At these rates, the ICES would save \$82,000 per year, a small amount when compared to the billion dollar trade figures, but still a savings.

The political vulnerability that results from the nation's lack of energy self-sufficiency. As stated in the proposed National Energy Plan, complete energy independence is an unrealistic goal. Nevertheless, programs that reduce the nation's need to import foreign supplies of oil and gas do reduce the influence that fossil fuels have on the political decision-making process. The fuel conservation of the ICES installation will contribute positively to the nation's political environment.

IV. B. The Negative Environmental Impacts

The potential negative environmental impacts of the construction and operation of the ICES were listed in Section II. They are discussed below in greater detail.

Construction Phase. The negative impacts of this phase are like those associated with similar construction projects. The length of the construction phase is difficult to estimate at this point in time, but it is probably about 6 months long. The negative impacts that will be experienced in this phase include:

Additional traffic along Downing Street and at the site on the north side of Jonas Clark Hall. Since Downing Street is near and Jonas Clark Hall is at the center of the campus this will have a disruptive effect. The inconvenience of heavy machinery on the compact campus will be greatest when the excavation equipment, dump trucks, and cement trucks are on campus.

The aesthetic impacts, both audio and visual, will persist throughout the construction phase. This impact should not be too great since the installation is not a large construction project, yet it is located in the center of the campus. Clearly, it will be necessary to insure that the most disruptive aspects of the construction phase be conducted when the University is not in session.

Particulate emissions, primarily dust, will be generated during the production process. Although these emissions will not be significant, they are mentioned here because of Worcester's air particulate problem.

In summary, the negative environmental impacts of the construction phase are mainly related to inconvenience. To keep this inconvenience to a minimum, it is important that the construction be undertaken during the late spring and summer months when the University is not in session.

B. The Operations Phase. The negative environmental impacts of the operations phase are considered to be more important than those of the construction phase because that phase will be relatively brief. The negative impacts of the operations phase include:

An increased emission of some air pollutants. While the ICES will reduce some emissions, NO_x emissions will increase by approximately 86.5 tons, CO will increase by 23.8 tons and HC will increase by 10.0 tons. The air quality impact is more negative if only the Worcester region is considered (instead of the New England region which includes the Massachusetts Electric generating plants). Clark's impact on the local air quality is listed in Table EIA-4.

Worcester is a "Non-Attainment" area for particulate matter at the present time. In the local area, emissions in this category will be decreased by 0.3 tons. The NO_x emissions do represent a major increase both at Clark and in the New England region. However, levels of NO_x in the Worcester region are well below the ambient standards and there is no photo-chemical smog problem in the region. It should be noted that the Regulations as Amended for the Control of Air Pollution exempt diesel engines from NO_x limits. In addition, NO_x is a dispersing pollutant, so higher emissions will not result in significantly higher concentrations at the site. As a result of these factors, the NO_x emissions do

not appear to result in a significant negative impact in the opinion of the EIA team and the Director of the Central Massachusetts Air Quality Control District. However, these emissions will be critically reviewed in the Air Quality Analysis at a later stage in the design process.

Liquid effluent. Oil treatment equipment will produce an effluent of _____ gallons per hour containing approximately _____ and 1% of oil. Water pretreatment prior to discharge of this waste will reduce the oil content to 80 ppm.

Noise and vibration of the diesel engine and generator. These impacts are potentially significant but can and will be eliminated through proper design and construction techniques. To insure that vibration is kept to a minimum, the diesel and generator will "float" on a cement pad independent from Jonas Clark Hall. Sound proofing will be applied to insure that the ICES will meet the noise standards as specified by the Commonwealth and approved by the EPA. Noise levels at other co-generation installations indicate that noise reduction should not be a difficult process. Commonwealth Gas Corporation's co-generation plant in Southborough, Mass. reduces the noise levels from 95-104dB in the generator room to 61-66dB in the observation room with standard construction techniques.

The increased presence of oil delivery trucks will result from the increase of 455,900 gallons of fuel consumed on the Clark Campus. At present there are approximately 123 deliveries per year. The ICES installation will require about 57 additional deliveries per year. This represents an increase of nearly 50%. Aside from their visual and olfactory impact, the increased

Table 2C-EIA-4

Estimated Air Pollution Impact--Present System and Proposed Grid Connected ICES

System	Annual Emission (in Tons/Year)				
	SO ₂	NO _x	CO	HC ₊	Particulates
<u>Present System</u>					
Utility boiler ^a	36.2	25.2	--	0.47	1.5
Clark boiler ^b	76.9	53.4	--	1.0	3.2
System impact ^c	113.1	78.6	--	1.47	4.7
<u>ICES System</u>					
Clark diesel ^d	55.1	140.7	23.8	11.0	0.6
Clark boiler	56.9	39.6	--	0.8	2.3
Utility boiler	-21.8	-15.2	--	-.29	-.9
System impact	90.2	165.1	23.8	11.5	2.0
<u>Net Change</u>					
At Clark	35.1	126.9	23.8	10.8	-.3
% Change ^e	46.0	238.0	NA	1080.0	-9.0
Auto equivalents ^f	--	2540.0	44.0	154.0	--
New England ^g	-22.9	86.5	23.8	10.0	-2.7
% Change	-20.0	110.0	NA	680.0	-57.0
Auto equivalents	--	1725.0	44.0	142.0	--

a. Based on generalized data for utility boilers burning residual oil with an ash content of 0.04% (by weight), sulphur content of 1.0% (by weight), weight of 7.83 lbs. per gallon, 148,000 Btu per gallon and a Btu to kwh ratio of 10,050 to 1. Assuming the consumption of 6.8×10^6 per year.

b. Based on the use of residual oil with the same characteristics as specified in note a and a boiler efficiency of 75%. Assuming a thermal load of 109×10^9 Btu per year.

c. Carbon monoxide levels (less than .01 tons) are considered negligible here.

d. Based on the manufacturer's specifications and the use of #6 residual oil with an ash content of 0.04% (by weight), sulphur of 1% (by weight), a weight of 7.83 lbs per gallon, and an energy value of 148,000 Btu per gallon. Assuming operation at full capacity for 7750 hours per year.

e. The percent change for carbon monoxide is meaningless since basically none was emitted previously.

f. Auto equivalents are included to provide a means of evaluating the relative significance of the net changes. They are based on EPA's estimates for the average emissions of all the motor vehicles operating in the U.S. in 1976.

g. The New England figures represent the net additional emissions of the Clark ICES and net reduction in the emissions at New England Electric System's residual oil fired generators. Assumes a net reduction in NEES's oil consumption by 279,000 gallons per year.

presence of 8000 gallons fuel trucks carries with it an element of risk. The increased presence of these trucks is only considered significant on the Clark Campus and Downing Street. Other streets, such as Main Street, are major truck arteries and 60 more trucks per year will be insignificant.

The visual and physical impact of the ICES building. The system will be installed in a separate building on the north side of Jonas Clark Hall. This location will require an addition of about 40 by 60 feet. This building will have an effect on the appearance of Jonas Clark Hall which is a focal point of the campus. The University Aesthetics Committee will review these proposals before a final decision is reached. The location will also intrude upon the campus, which is already lacking in "green space." However, this location reduces the levels of unknown risk that are involved with installing the system within the 90 year old building.

The audio and visual impact of the cooling tower may produce negative impacts. A more definite evaluation will be presented after the exact sizing and location of the cooling tower is determined.

Elements of unknown risk accompany any alteration of an existing system. To reduce potential of this negative impact becoming significant, the ICES system will use only proven equipment and engineering techniques. The experience of the technical partners in co-generation should reduce this threat still further.

In summary, the known negative impacts from the ICES are not deemed significant. It should be noted that the ICES system's negative impacts are relatively contained within the Clark University campus. As a result, almost all of the negative impacts

are experienced by the same people who benefit from the more significant positive impacts. Negative impacts on third parties, such as the local community, are minimal.

V. Coordination with Federal, State, Regional and Local Plans.

The ICES installation is only feasible if it can comply with all of the appropriate statutes, codes and regulations. The importance of complying with these legal and institutional factors has been recognized throughout the planning process. Aside from these specific factors, it is also important that the ICES not conflict with any policies and programs of Federal, state and local governments. The relevant items and the steps that have been undertaken in response to them are discussed below. The specific codes and letters from appropriate regulatory and planning officials are contained in Appendices 2B and 2C.

Environmental Impact Analysis. Regulations regarding overall environmental impact analysis are presented in Chapter III, U. S. Energy Research and Development Administration, Part 711 - Guidelines for Environmental Review published in the Federal Register, 26 January 1977, pp 4826-4833. (See Appendix 2B). These regulations require that an Environmental Impact Assessment (EIA) be

written as specified in Part 711 - 25 of the regulations. This document is a preliminary draft of an EIA based on the present state of knowledge on the Clark ICES installation. This report will be updated and expanded as the planning process continues.

The applicability of the state requirements for an environmental impact assessment is unknown at the present time and will depend on the degree of involvement of the Commonwealth in the ICES project. A preliminary draft of a Massachusetts Environmental Assessment Form is included as section 3 of this report. It was completed in accordance with specifications contained in "Preparation of Environmental Impact Reports" (see Appendix 2B).

Air quality standards. The exhaust emissions of the ICES installation are subject to state and Federal air quality standards. The main applicable regulations are the Federal and Massachusetts Air Quality Standards (40 CFR 50), Requirements for Preparation, Adoption, and Submittal of Implementation plans (40 CFR 51), Interpretive Ruling for Implementation of the Requirements of 40 CFR 51.18, and Regulations as Amended for the Control of Air Pollution, Dept. of Environmental Quality Engineering, the Commonwealth of Massachusetts as amended through 13 June 1975. (All of the above regulations are contained in Appendix 2B).

Emissions figures have been reviewed by Mr. Edmond G. Benoit, Chief, Central Massachusetts Air Quality Control District. Mr. Benoit has stated that, based on presently available data and pending more detailed analysis, the project would not be in

violation of air pollution regulations (See letter in Appendix 2C). Moreover, Mr. Benoit is very supportive of the project and its ability to provide better data as to the air quality impact of co-generation systems. The staff of the Central Massachusetts Air Quality Control District will be asked to recommend the most appropriate monitoring equipment to gather this data.

Further discussions have been held with air quality specialists at EPA's Region I, Boston office. They confirmed that compliance with all state standards will also guarantee compliance with Federal regulations.

Noise regulations. The Director of the Central Massachusetts Air Quality Control Board has jurisdiction over noise pollution under the Regulations as Amended for the Control of Air Pollution, Dept. of Environmental Quality Engineering, Commonwealth of Massachusetts, adopted 26 Jan. 1972 and amended through 13 June 1975. (See Appendix 2B). He foresees no difficulty in meeting these standards. Representative of the EPA noise pollution branch in Boston also have been contacted. They stated that the Commonwealth's standards either meet or exceeded theirs and would be acceptable.

Building Codes. The applicable building codes are contained in Article II, "Heating Equipment and Appliance mounting, Clearances and Connections." of the State Building Code. In addition, boilers and unfired pressure vessels are subject to the provisions of Chapter 146 of the MGLA as amended. These issues

have been reviewed with Mr. Norton Remmer, Commissioner, Dept. of Building Code Inspection of the City of Worcester. Commissioner Remmer states that compliance with all requirements of the building code can be achieved by applications of standard designs and construction techniques. (See letter in Appendix 2C.) The provisions of Chapter 146 require the approval of certain boilers and pressure vessels by the Board of Boiler Rules of the State Department of Public Safety. Such approval will be obtained, if appropriate, once detailed designs and specifications are known.

Zoning. The City of Worcester Zoning Ordinance applies to the University and the ICES installation. Clark is located in a residential district which is permissible under Section 15A (6) of the code (See Appendix 2B). The ICES installation was discussed with Mr. Remmer, Commissioner, Dept. of Building Code Inspection, City of Worcester. He stated that the project would not violate existing zoning regulations (See letter in Appendix 2C). The Office of Community Planning and Development was also contacted to insure that the installation did not interfere with the plans and programs of that agency. They indicated that the project would not affect their plans. The Worcester Redevelopment Authority, an agency that operates in the vicinity of the Clark campus, has also indicated that they have no objection to the ICES installation (See letter in Appendix 2C).

To conclude, the Clark ICES proposal does not conflict in a significant manner with any specific legal and institutional requirements or the plans and policies of related governmental

agencies. On the contrary, the majority of these entities supported the ICES proposal on the basis of the positive impacts such a system would have on energy conservation and economic welfare of the community. The advice of the regulatory personnel have been of great assistance to the Environmental Impact Assessment Group. The Group will continue to seek their advice and opinions in the future.

VI Description of Alternatives.

There are four sets of alternatives open to Clark University. Those being: (1) to continue with present practices; (2) to institute additional strong conservation measures to reduce energy demand; (3) to install a totally independent integrated energy system; or (4) to select a different grid connected ICES system.

Continue with present practices.

This alternative would have no environmental impacts at Clark University, it would however continue unabated use of oil within the New England area. This would, therefore, be contrary to the national and regional objective of fuel conservation. Furthermore, it would continue Clark's vulnerability to cost increases in fuel and electricity with the inherent danger to its financial stability and the indirect effect of financial instability on the student body, the faculty and the community.

Institute additional conservation measures.

The University has already instituted strong conservation measures. The principle one being an IBM System 7 load dropping

computer which has 26 electric controls and 13 steam controls. The computer is programmed to balance loads, essentially reducing peak demand. The introduction of this conservation device in conjunction with simpler conservation rules has already resulted in a reduction of about 35% for the thermal load and 45% of the electric load. Investigation of further conservation measures indicate that such measures are likely to produce adverse effects on the Clark community, produce increasingly marginal conservation yields and as a corrolary, increases in marginal costs. Fuel savings would be only proportional to energy input reduction with no improvement in fuel to energy conversion efficiency.

Independent integrated energy system

Total energy plants for the Clark campus not connected with the existing electric grid have been investigated in several studies. Such systems have generally the same advantages as a grid connected ICES. Cost, however, are higher as system's reliability must be achieved by the installation of standby units. Engineering studies show that the cost of interconnection including standby charges for electricity are lower than those of standby units.

Different grid connected ICES

A large number of alternative ICES installations including differently sized diesel units, steam turbines and gas turbines were investigated. These investigations showed that diesel units produced the best balance between efficiency and tech-

nologic risk, that generally larger units produced increased efficiency and rate of return and also higher initial cost. On environmental grounds few differences can be ascertained except that larger units are likely to increase aesthetic problems, air pollution but reduce oil consumption. On economic grounds, larger units in addition to increased initial cost, represent higher opportunity cost and larger risks.

VII Conclusion

Based on the previous section of this environmental assessment, the following conclusions can be derived.

- (1) There will be no significant negative or positive environmental impacts at the project site, i.e. the Clark campus. Physical changes will be minimal and do not affect ecologically sensitive areas. Aesthetic effects and noise effects can be mitigated by proper facilities design. Air pollution effects at site will be minimal as the increase in pollutants that have localized effects such as CO, SO₂ and particulates is small.
- (2) Socio-economic effects at the project site are beneficial. Significant financial savings accrue to Clark University and the presence of the demonstration project will enhance the reputation and academic programs of the University.
- (3) Community environmental effects of the project are negative, however, only to a small degree. The significant output of NO_x will increase the NO_x level in Worcester. This however is not serious as the present ambient NO_x level is well below ambient

standards and there are no local photo chemical smog problems. Traffic in the area surrounding Clark will be increased slightly by the increased frequency of oil delivery trucks and there may be some temporary nuisance conditions during construction.

(4) Socio-economic effects on the community are expected to be small but positive. The increased local expenditure for construction, operation and maintenance should to some degree enhance the community.

(5) Regional environmental impacts of the project are small on a national scale but they are positive and as a demonstration project, this is highly significant. Oil savings of nearly 8000 barrels per year may not be large when compared with the present national consumption of that fuel, but being nearly 25% of the fuel consumed for Clark's need, they are a significant indication of the contribution that grid connected ICES can make towards the national goal.

(6) Regional and national socio-economic impacts, while insignificant by themselves, are important as indicators of the opportunities that exist, through cooperation of individual institutions, utilities and government towards achievement of socio-economic goals.

(7) The overall increase in the emission of nitrogen oxides, carbon monoxide and hydrocarbon indicate that the increased efficiencies of co-generation systems are not without environmental cost. The increases from a single ICES at Clark are not

considered significant. However, it is important to project the impact of many such installations to gain a more thorough understanding of the total environmental impact. As a demonstration project, the Clark ICES will provide more precise data to anticipate these impacts. At present, the figures suggest that large numbers of diesel powered ICES should not be installed in regions with high NO_x concentrations or high incidence of photochemical smog without careful evaluation of their impact.

9. Summary of Proposal (narrative):

The co-generation system would involve the installation of a Sulzer 8 cylinder, ASL/30 diesel rated at 1494 BHP at 900 RPM. The diesel would generate 1405 kilowatts of electricity and provide 3.67×10^6 Btu/hr of energy to the University heating plant. When in operation the system will meet the University's entire electrical demand. The system will be integrated with Massachusetts Electric Company. The utility has agreed to purchase electricity generated in excess of the University's demand and to sell electricity to the University when the generator is not in operation or is otherwise unable to fulfill the University's demand. The thermal load of the University that exceeds the diesel's output will be provided by the present boiler system.

II. ACTIVITY DESCRIPTION.

A. Include an original 8½ x 11 section of a U.S.G.S. 7½ minute, 1:24,000 scale map with the activity or project area boundaries delineated. (Original U.S.G.S. sheet required for filing with Secretary only; copies may be supplied to others.) Include multiple maps if activity or project is larger than the area delineated on a U.S.G.S. 1:24,000 scale map. Include maps, diagrams or sketches at a larger scale if the features of the activity or project cannot be clearly shown at the 1:24,000 scale.

B. Give a brief description of the present use of the area or areas affected in 5. Indicate the number of acres affected that are:

1. Developed

3. Wetland

2. Open Space

4. Shoreline

5. See Attached

C. Give a brief description of the proposed activity, including all phases and characteristics, in 2.

1. Fill in the following dimensions, if applicable:

a. Total Activity Area (Acres):

d. Number of Stories:

b. Length In Miles:

e. Number of Parking Spaces:

c. Number of Housing Units:

f. Vehicular Traffic Generated Per Day:

2. See Attached

D. Describe how your agency is involved in the activity in 4. Specify:

1. Permit or Program Type:

2. Pertinent Governing Statute(s) or Regulation(s):

3. Other State Agencies Involved:

4.

B. 5.

The present use of this area adjacent to Jonas Clark can be described as a small open space plot. Location of the glass enclosed structure housing unit will, in the belief of this team, enhance the aesthetic value of this area.

C. 2.

The proposed action involves the installation and operation of one 1405 Kw Sulzer 8 cylinder ASL/30 diesel, 1494 BHP at 900 RPM. The machine is expected to operate 7750 hrs/yr w/110⁰hrs of down-time or maintenance.

The rate of fuel consumption and exhaust specifications as supplied by the manufacturer are as follows:

Fuel consumption: .357 lbs/BHP/HR

Exhaust Specs.: No_x: 8.3 gr/BHP/HR

CO: 1.4 gr/BHP/HR

HC+: .65 gr/BHP/HR

Particulate: .031 gr/BHP/HR

SO₂: 3.25 gr/BHP/HR

It will continue to afford a view of the Goddard Library as well as the Jonas Clark facade. As the structure itself will highlight the operation of the facility, an educational function--for the University as well as the community--will be served.

III. ASSESSMENT OF POTENTIAL ENVIRONMENTAL IMPACT

Answer the following questions by placing an "X" in the appropriate YES/NO space; consider activity, construction, operational, as well as indirect impacts.

Indicate under "Explanation" why significant impact is considered likely or unlikely to result.

A. OPEN SPACE AND RECREATION

1. Might the activity affect the condition, use or access to any open space and/or recreation area?

NO YES

If YES, specify area(s) and acreage(s) affected:

- (1) _____
- (2) _____
- (3) _____
- (4) _____
- (5) _____

Acreage

Duration

Severity

Enter Code

2. Explanation:

No significant impact on use or access to any open space and/or recreational area is expected, as the location of the facility is not in or near any such area.

B. HISTORIC RESOURCES

1. Might any site or structure of historic significance be affected?

NO YES

If YES, state level of historic significance:

Significance

Duration

Severity

2. Might any known archaeological site be affected by the activity?

NO YES

If YES, specify duration and severity:

Duration

Severity

3. Might any known paleontologic site be affected by the activity?

NO YES

If YES, specify duration and severity:

Duration

Severity

4. Explanation:

No significant impact is expected on any historical, archaeological or paleontological site as the location area has undergone previous excavation - piping, etc. - without damage to any of the above.

After checking with the necessary commissions it has been concluded that the project is not located in a sensitive area.

C. ECOLOGICAL EFFECTS

1. Might the activity affect any natural feature adjacent to or near the activity area?

If YES, specify natural features affected:

(1) _____
 (2) _____
 (3) _____
 (4) _____
 (5) _____
 (6) _____

NO YES

Duration Severity Enter Code

2. Might the activity affect wildlife or fisheries?

If YES, specify wildlife or fisheries affected:

(1) _____
 (2) _____
 (3) _____
 (4) _____

NO YES

Duration Severity Enter Code

If YES, specify whether any rare or endangered wildlife or fisheries species might be affected:

NO YES

3. Might the activity affect natural vegetation?

If YES, specify vegetation and acreage(s) affected:

(1) _____
 (2) _____
 (3) _____
 (4) _____
 (5) _____
 (6) _____

Acreage

NO YES

Duration Severity Enter Code

If YES, specify whether any rare or endangered plant species might be affected:

NO YES

4. Explanation:

D. ENVIRONMENTAL HAZARDS

1. Might the activity involve the use, storage, release of, or disposal of potentially hazardous substances?

If YES, specify substance type and rate of usage:

(1) _____
 (2) _____
 (3) _____

Usage Rate

NO YES

Duration Severity Enter Code

2. Might the activity involve alteration of riverine floodplains, inland wetlands, or coastal wetlands?

If YES, specify duration and severity of impact:

NO YES

--	--

Duration Severity

3. Might the activity involve construction or other action within geologically unstable areas? X NO YES

4. Explanation: Operation of this facility does not require the use, storage or release of potentially dangerous materials. In addition, its location is not near/on wetlands or a specifically unstable geological area. For these reasons, the facility is not regarded as posing a potential environmental threat.

E. RESOURCE CONSERVATION AND USE

1. Might the activity affect or eliminate land suitable for agricultural or timber production? X NO YES

If YES, specify present agricultural land use and respective acreage(s) affected:

(1) _____ (2) _____ (3) _____

 Acreage

 Duration

 Severity

 Enter Code

2. Might the activity affect potential use or extraction of an indispensable or scarce mineral or energy resource? NO X YES

If YES, specify resource affected and approximate amount:

(1) Oil _____ (2) _____ (3) _____

4	8	7	6

 Tons

3

 Duration

3	6

 Severity

5	2	1

 Enter Code

3. Explanation: As this facility is not located in an agricultural area, and any excavation would be to nominal depths (no more than 12') in a shale ledge, there are no expected impacts on any resources due to construction. However, operation of the ICES will result in a net savings of approximately 8,000 barrels of oil/yr. These savings are important in light of our national goal to decrease energy consumption.

F. WATER QUALITY AND QUANTITY

1. Might the activity affect the quantity of water resources, within, adjacent to, or near the activity area? X NO YES

If YES, specify water source affected and respective amount (gallons/day):

(1) _____ (2) _____ (3) _____ (4) _____

 Gallons/Day

 Duration

 Severity

 Enter Code

2. Might the activity result in a deleterious effect on the quality of any water resource areas or watersheds? X NO YES

If YES, specify water resource that might be affected:

(1) _____ (2) _____ (3) _____ (4) _____

 Duration

 Severity

 Enter Code

If YES, specify possible substance causing effects:

- (1) _____
- (2) _____
- (3) _____
- (4) _____

Duration

Severity

Enter Code

3. Explanation:

G. AIR QUALITY

1. Might the activity affect the air quality in the project area, immediately adjacent areas, or the Air Quality Control Region?

_____ NO X _____ YES

If YES, specify possible substances affecting air quality:

- (1) Construction - Dust
- (2) Nitrogen Oxides (No_x)
- (3) Particulate
- (4) Hydrocarbons (HC+)
- (5) Sulphur Dioxide (SO₂)
- (6) Carbon Monoxide (CO)

1
3
3
3
3
3

Duration

1	6
3	6
2	6
2	6
2	6
2	6

Severity

7	0	6
7	0	2
7	0	6
7	0	4
7	0	1
7	0	3

Enter Code

If YES, specify whether any key receptors may be in the affected area:

- (1) Educational Facility (Clark University)
- (2) _____
- (3) _____

3

Duration

2	6

Severity

7	2	3

Enter Code

2. Explanation:

See attached.

H. NOISE

1. Might the activity result in the generation of noise?

_____ NO X _____ YES

If YES, specify noise source:

- (1) Construction
- (2) Operation - i.e., cooling tower
- (3) _____

1
3

Duration

1	6
1	6

Severity

8	0	1
8	0	6

Enter Code

2. Explanation:

See Attached.

G. 2. Explanation:

The operation of the diesel will affect the air quality in the project area to a minor degree. Installation of a TEP will alter air pollution impacts, not only because the TEP based system will use less fuel, but, more importantly, because air pollution from internal combustion engines has a different character from that from furnaces. The greatest increases will be in amounts of NO_x and SO₂ emitted due to the high operation temperature of the equipment. For the former, and high sulphur content of #6 residual oil, the increase in emission is directly related to the increased capabilities of the new system and must be considered in light of possible reductions regionally owing to the overall expected decrease in oil consumption.

H. 2. Explanation:

The proposed project is expected to have an imperceptible noise impact on the environment. Noise levels inside the building will meet the OSHA standard of 85 DB. All measures will be utilized to insure against any disruption of the present environment, in and around Clark University. Construction noise will be kept to a minimum through the use of heavily muffled equipment. No negative noise impact is expected during the operation phase owing to use of noise abatement materials in construction of, and around, the equipment housing.

I. AESTHETICS

1. Might the activity cause a change in the visual character in or near the activity area?

___ NO ___ YES

If YES, specify natural and cultural features that may be changed:

- (1) Old man-made structure (if TEP is placed
- (2) outside)
- (3) _____
- (4) _____
- (5) _____
- (6) _____

4	2	6	9	0	1

Duration Severity Enter Code

2. Explanation:

See Attached.

J. PLANNING

1. Will the activity require a variance from or result in a potential violation of any statute ordinance, by law, regulation, or standard, the major purpose of which is to prevent or minimize damage to the environment?

___ NO ___ YES

If YES, specify variances and/or statutes:

- _____
- _____
- _____

2. Will the activity require certification, authorization, review of plans, or issuance of a permit by any local, state or federal agency?

___ NO ___ YES

If YES, specify agency and action required:

- _____
- _____
- _____

3. Will the activity comply with all federal, state and local land use, transportation, open space, recreation and conservation plans?

___ NO ___ YES

If NO, state plan type and specific agency concerned:

- (1) _____
- (2) _____
- (3) _____
- (4) _____

Enter Code

4. Explanation:

1. 2. Explanation:

With the construction of a new building designed to house Clark's Total Energy plant, a part of the Jonas Clark structure, approximately 8 feet high and 40 feet long will be obstructed. It is the belief of the Environmental Group that aesthetic values added outweigh the loss arising from obstruction of the Jonas Clark side facade. This belief lies in our conviction that an attractive structure, as the one planned, allowing view of Plant operations, has greater aesthetic value than the small part of the facade that will be obstructed. In addition, this feature will enhance relations with the community surrounding Clark as the plant will provide an additional site of interest on the campus.

IV. FINDINGS AND CERTIFICATION

A. It has been determined that this project is not one which may cause significant damage to the environment (Negative Assessment).

B. It has been determined that this project may cause significant damage to the environment (Positive Assessment).

1. The draft impact report will be submitted on or about: _____

2. The draft impact report will be: Standard

Extensive

3. The draft impact report will be combined:

4. The draft impact report will be joint in conjunction with:

C. I hereby certify that this assessment has been or will be, if applicable regulations provide for subsequent circulation, duly circulated to the Attorney General, the appropriate Regional Planning Agency, and other review agencies as required by Appendix B.

DATE

Signature of Responsible Officer

(print or type) Name of Responsible Officer

Signature of Preparing Officer (if different from Responsible Officer)

Address

Telephone Number

4. Individuals and Offices Consulted

Edmond G. Benoit
Chief, Air Quality Control Section
Central Mass Air Quality District

Tom Cusson
Central Mass Air Quality District

Al Nicks
Noise Pollution
EPA, Boston

John Lynch
E.I.S. Office
EPA, Boston

Linda Murphy
Air Quality: New Sources
EPA, Boston

Charles O'Connor
Office of Planning and Community Development
Worcester, Mass.

Norton S. Remmer, P.E.
Commissioner: Department of Code Inspection
City of Worcester, Massachusetts
419 Belmont St. 01604



NORTON S. REMMER, P.E.
COMMISSIONER

City of Worcester, Massachusetts

DEPARTMENT OF CODE INSPECTION

419 BELMONT STREET 01604

TELEPHONE (617) 798-8111

Mr. Lawrence Landry
Vice President of Finance
Clark University
950 Main Street
Worcester, Mass. 01610

Dear Mr. Landry,

This letter will serve to confirm the conclusions reached at a meeting on Monday, April 11, 1977 relative to regulations controlling the proposed installation of mechanical facilities at Clark University in conjunction with an ERDA demonstration project.

1. **Zoning.** In accordance with the Zoning Ordinance of Worcester and the Official Map the proposed use would not be in violation of zoning and could proceed routinely for approval.
2. **Building Code.** There are no requirements of the Building Code relative to the proposed locations which were reviewed for which compliance could not be achieved by standard design and construction techniques.
3. All other requirements of the City relative to construction based upon the proposed preliminary concepts, would be subject to routine procedures.
4. This office cannot take responsibility for State mandated and administered requirements relative to environmental impact, and pollution controls. These items would have to be reviewed by the appropriate authorities.
5. Certain Boilers and Unified Pressure Vessels ^{fixed} require approval by the Board of Boiler Rules of the State Department of Public Safety as indicated in Sections 1100.11 and 1103.1 of the State Building Code, and this office would have no jurisdiction over those approvals.

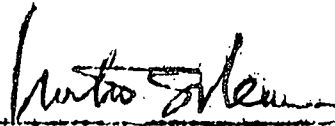
Norton S. Remmer
Commissioner



DEPARTMENT OF CODE INSPECTION
CITY OF WORCESTER
MASSACHUSETTS 01604

NORTON S. REMMER, P.E.
COMMISSIONER

419 BELMONT STREET
TEL. 617-798-8111

November 3, 1977

Mr. Lawrence Landry
Vice President of Finance
Clark University
950 Main Street
Worcester, MA 01610

Dear Mr. Landry:

This Department previously submitted a letter (copy attached) relative to the installation of mechanical facilities for generating power at Clark University.

A review of the current proposed specifications has not altered the decisions reached previously. Within those areas for which this Department has primary legal responsibility relating to the project, i.e., Building Code and Zoning Ordinance, I can see no reason to expect that the project as proposed would not meet zoning ordinance requirements or could not be constructed in accordance with the Building Code or its reference standards, using standard design and construction techniques.

Norton S. Remmer, P.E.
Commissioner

NSR/cv
c.c. Mr. Harry Shwarz
Environmental Affairs Program

APPENDIX 3A

Engine Operating Experience and Guarantees

APPENDIX 3A

Engine Operating Experience and Guarantees

Operating Experience

Both Sulzer and Superior have had extensive experience with the candidate engines burning distillate oil. Sulzer's experience has been with low-temperature (less than 200°F) water-jacket cooling, but they feel that the change to ebullient cooling is quite straightforward. Superior's experience with their engine is largely with ebullient cooling.

We believe that the behavior of the engine when using residual oil is the most sensitive question. Sulzer's experience with heavy-oil-burning engines is considerable, since they have about 50% of the market for large marine engines. They also have heavy-oil experience with engines of the same design as the one proposed for Clark. They have run 6-cylinder ASL 25/30 engine in the laboratory from 1969-1972. They accumulated 1130 hours of operation, 880 on heavy fuel and 250 on distillate oil during break-in, starting and stopping. The sodium/vanadium content of the fuel varied between 13ppm/76ppm and 27ppm/173ppm. Measurements of wear were made after 300 hours of operation with the 27/173 Na/V fuel. The chromium-plated top piston ring had wear of about .0015inch/1000 hours. Liner wear was .0004 to .0008inch/1000 hours. No wear could be measured on valves or the piston ring grooves. According to Sulzer, rate of wear on piston ring and liner drops to about 1/3 of the initial rate after about 5000 hours. Assuming this change is linear for the first 5000 hours and remains constant thereafter, the wear on the top piston ring would be .005 inch after 5000 hours and .0075 inch after 10,000 hours. The liner wear would be .00133 to .0027 inch after 5000 hours and .0019 to .0038 inch after 10,000 hours. From these values, Sulzer has predicted the lifetimes of various components. These predicted lifetimes are presented in Appendix 4B, Table 4B-1, where they are used to estimate maintenance costs for the engine. In addition to the test engine, two ASL 25/30 engines have accumulated more than 10,000 hours burning residual in regular service.

Superior had 10 installations of their older in-line version of models 40, 60, and 80, engines designed for crude or residual oil. However, they do not know what the experience of these sites has been. We obtained useful information from one of these sites, an eight-cylinder engine rated at 1000kw that has run about 107,000 hours for the Florida Keys Electric Corporation in Marathon, Florida. About 75% of those hours were for operation between 1954

and 1964, using residual fuel. In 1964 the plant changed to #2 oil as the price difference between #2 and #6 oils disappeared. A further consideration was that the vanadium content in the available fuel had increased, and they were not set up to treat vanadium. A spokesman for Florida Keys stated that wear on valves and other engine parts was not appreciably different for #2 and #6 oils, except when there were high vanadium levels in the oil (unfortunately the spokesman could not say definitely what a high vanadium level was). There was an increase in maintenance costs for such components as injectors, fuel pumps, and other fuel handling equipment.

To summarize, Sulzer has experience operating their candidate engine with residual fuels; Superior does not. Sulzer does not have experience with the ebullient cooling of their engine while Superior does. Both manufacturers have considerable experience burning heavy fuels in other engines, but Sulzer's experience is probably more extensive as they are the larger company.

Guarantee Terms

Both companies offer us their standard guarantee. Sulzer will guarantee the engine for 12 months from the commissioning of the power plant. The guarantee applies to an ebulliently cooled, residual-oil-burning engine, but the engine must maintain limits of sodium/vanadium of 30ppm/100ppm. The guarantee covers repair or replacement of defective parts; the details of the guarantee can be negotiated at the time of purchase. The guarantee will not cover normal wear, improper maintenance, incorrect operation, etc.

Superior's guarantee is similar. It is also for one year and covers repair or replacement of defective parts. Their guarantee requires regular monitoring of the fuel input to the engine to ensure that limits of sodium/vanadium of 5ppm/30ppm are not exceeded.

APPENDIX 3B

Plant Descriptions

I. ENGINES

A. Superior Engine

The Superior engine is Model 40-X-16 (V type). It has 16 cylinders, 900 RPM, and is rated at 2120 bhp at 100% load. The generator output at 100% load is 1500 kw. The engine has a break mean effective pressure of 141.4 at 100% load and is turbocharged. As currently available it does not use heavy oil. Cooper Energy Systems has advised that with modifications the engine will be suitable for residual oil.

The following design changes would be necessary to make it capable of burning residual oil as fuel:

1. Injection pumps would require special clearanced plungers and barrels and have a bypass to allow an adequate flow of oil through the pump for cooling.
2. The injection nozzles would require special clearances in the area of the valve and seat.
3. The injection nozzle tips would require low sac volume and an orifice size selected for the particular fuel used.
4. The fuel would require pre-treatment including, as a minimum, water washing and centrifuging. Preheating would also be required to reduce the fuel's viscosity in order to make it more easily handled for the treatment necessary. We would be working with commercially available manufacturers of fuel treating equipment to make the final selection. Once the fuel is treated, it would also require additional filtration at the engine. Further heating of the fuel may also be required before and after filtration depending upon the fuel viscosity.
5. The engine would be equipped with a duplex fuel system which would allow the engine to start and stop on No. 2 diesel fuel and transfer to residual operation after the engine is running. This will ensure that there is no #6 oil in the engine when the block is cool.
6. Reduction in metallic alloys in the fuel system may be required depending upon the amount of corrosives in the residual. Many residuals contain extremely high sulphur and water content which, under the right conditions, can form corrosive acids.

7. The use of a high total base number (TBN) lubricating oil would be required in the crankcase along with more frequent oil change periods. The high TBN oil has high alkaline reserve preventing acid build-up in the crankcase and minimizing corrosion in this area. The manufacturer would like to have a minimum of one month available for testing an engine with the residual fuel selected.

B. Sulzer Engine

The Sulzer engine is Model 8 ASL 25/30 (in-line cylinders). It has eight cylinders, 900 RPM and is rated at 1984 bhp at 100% load. The generator output at 100% load is 1405 kw. The engine is currently available as a residual oil engine. It has a brake mean effective pressure of 242.7 at 100% load and is turbocharged. There are two A 25/30 engines burning #6 oil. They have accumulated over 10,000 hours of service.

Both the Superior and Sulzer jacket and air cooler will be cooled by Glycol-to-air radiators.

II. STEAM SYSTEMS (common to Superior and Sulzer engines)

- A. The new diesel plant will utilize the existing deaerator, condensate system and feedwater pump of the university boiler plant.
- B. A new waste heat boiler will be installed. This will be rated at approximately 2500 lb/hr at 125 psig saturated steam. The unit will be equipped with a gas bypass valve to control steam pressure. The boiler will be equipped with level controls, high and low water alarms.
- C. The ebullient jacket cooling system consists of supply and return piping to a steam reservoir separator. The reservoir/separator will be equipped with level controls and high and low-level alarms. Make-up water to the system will be via a water softener. Pressure in the system will be maintained by a modulating steam valve which will release the steam to the 15 psig system. Any steam not required by the 15 psig university system will be condensed in a radiator condenser.

III. FUEL SYSTEM

Two fuels are required for engine operation, No. 2 and No. 6. No. 6 oil is the basic fuel. No. 2 oil is used for starting and shutting down the engine. The oil storage system will consist of an existing 20,000

gallon No. 6 oil storage tank and a buried 2000 gallon No. 2 oil storage tank. Two fuel oil transfer pumps will be required, one for No. 2 oil and one for No. 6 oil. These pumps will be located in the diesel plant building. The No. 2 pump will take oil from the No. 2 tank and pump to a 300 gallon day tank in the diesel plant. The No. 6 oil transfer pump will pump the No. 6 oil from the buried tank to the oil treatment system. After treatment, the oil will be pumped to an elevated 600 gallon oil storage system. From this point an engine driven pump will pump the oil to the engine.

IV. FUEL TREATMENT SYSTEM

The fuel treatment system is described in Appendix 3D of this report.

V. ELECTRICAL SYSTEM

The diesel generator will generate power at 13,800 volts. The unit will operate continuously, in parallel with the Massachusetts Electric Power System. The existing Jonas Clark 208V electrical system will be tied into a new switchboard located in the diesel plant. This power will feed the auxiliaries and lighting for the diesel plant. The 13,800V power will be fed (via the new switchboard) to the Goddard Library via two buried conduits. At the distribution system in Goddard, the power, which can flow into or out of Clark, will be metered in each direction.

PLANT DESCRIPTION
DISTILLATE OIL ENGINE

I. ENGINE

A. The engine selection for distillate oil is the Colt Fairbanks-Morse, opposed piston, 9 cylinder, 720 RPM, rated at 2160 bhp. The generator output at 100% load is 1531 kw. This engine has many years of experience and is recognized as a highly reliable engine.

II. STEAM SYSTEMS

The steam system would be the same as for the heavy oil engines.

III. FUEL SYSTEM

The fuel system will consist of a 20,000 gallon buried distillate oil tank and transfer pump and a day tank from which the oil would be pumped to the engine by the engine driven oil pump.

IV. FUEL TREATMENT SYSTEM

There is no fuel treatment system required for the distillate oil.

V. ELECTRICAL SYSTEM

This is the same system as described for the heavy oil engine.

APPENDIX 3C

Performance of the Candidate Systems

APPENDIX 3C

Performance of the Candidate Systems

For each diesel generator considered, heat balance data were obtained from the engine manufacturer in terms of Btu per bhp-hr. The heat balance parameters given by the manufacturer were:

Work Output
Jacket Water
Lubricating Oil Cooling
Exhaust Gases
Exhaust Latent Heat
Radiation and Unaccounted

Exhaust gas flows and exhaust gas temperatures were also obtained from the engine manufacturer for each engine evaluated. This data was then used to obtain system heat balances, showing the amount of 125 psig and 15 psig steam flows.

A characteristic of diesel engines is that performance (i.e. heat balance in terms of Btu/kwh) is fairly constant down to about 50% of design load and then drops off substantially. We show this by showing heat balances at 50% load.

For each candidate system, the following assumptions were used to determine the best balances:

1. The deaerator in the existing heating plant was used.
2. The boiler blowdown was taken to be 5%.
3. 95% of the steam was returned. The return temperature was 160°F. The makeup water temperature was 60°F.
4. The final feedwater temperature was 225°F.
5. The boiler exit gas temperature for fired and heat recovery boilers was fixed at 325°F. The diesels were evaluated with ebulliently cooled jackets. An analysis of the campus heating system showed that the maximum average low pressure steam duty which could be utilized by the heating system was 2.4×10^6 Btu/hr.
6. Heat balances were evaluated taking the efficiency of the conventional systems as either 75% or 85%. The actual figure is near 75%.

Figure 3C-1 is a schematic for the heat balance calculation for a diesel.

The heat rate for the engine was calculated by comparing the fuel requirements for the proposed demonstration system with those for the conventional system. The fuel to the engine per Kwh is:

FIGURE 3C-1
Schematic for Diesel
Heat Balance

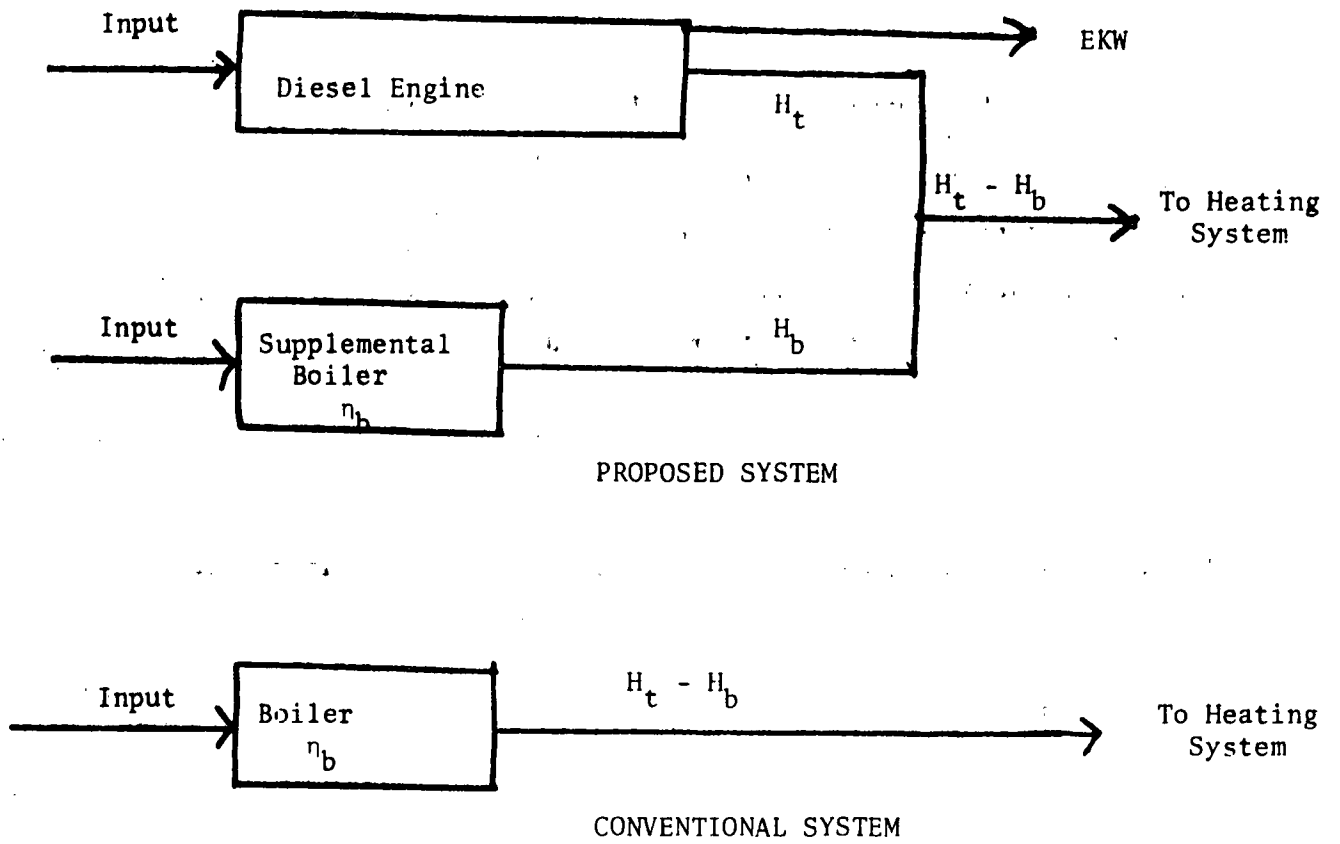

$$\text{EHR} = \frac{\text{lb fuel}}{\text{bhp-hr}} \times \frac{1}{.746} \times \text{heating value (Btu/lb fuel)} \quad (1)$$

where

EHR = engine heat rate (Btu/Kwh)

The total fuel per Kwh used by the proposed system is then obtained by adding boiler fuel used to supplement the engine thermal output:

$$\frac{H_{ds}}{\epsilon_T} = \text{EHR} + \frac{H_b}{\eta_b \epsilon_T} \quad (2)$$

where

H_{ds} = total fuel used by demonstration system (Btu/hr)

H_b = thermal output of supplemental boiler (Btu/hr)

ϵ_T = electricity produced by engine (Kw)

The total fuel used by the conventional system is just the boiler fuel required to obtain the required thermal output.

$$H_{cs} = \frac{H_b + H_t}{\eta_b} \quad (3)$$

Subtracting equations 2 and 3 then results in the desired incremental heat rate:

$$\text{HR} = \text{EHR} + \frac{H_b}{\eta_b \epsilon_T} - \frac{H_{cs}}{\epsilon_T} \quad (4)$$

$$= \text{EHR} - \frac{H_t}{\eta_b \epsilon_T}$$

We see from equation 4 that the term H_t/η_b is the useful thermal output (from the exhaust and cooling jacket) generated by the diesel. It replaces boiler fuel which would have had to be utilized in a conventional boiler. This fuel is therefore credited to the diesel.

Another key parameter is the cost of fuel attributable to generation of electricity. This is the cost of fuel for running the system less the cost of fuel that would be used in the existing boiler to make up the heat output of the candidate system. This can be expressed

$$fc_T = f_e \times EHR - \frac{f_b \times H_t}{\eta_b \epsilon_T} \quad (5)$$

where

fc_T = cost of fuel attributable to generation of electricity ($\$/kwh$)

f_e = price of fuel used in engine ($\$/10^6$ Btu)

EHR = fuel input to engine (or high pressure boiler for a steam turbine) (Btu/kwh)

f_b = price of fuel that would be used in a conventional boiler ($\$/10^6$ Btu)

H_t = useful thermal output of system (Btu/hr)

η_b = efficiency of conventional boiler

The derivation of equation 5 is similar to that for the heat rate, equation 4. When the same type of fuel is used for both the engine and the boiler, or when the costs for these fuels are equal, fc_T is simply the fuel cost multiplied by the heat rate.

The performance data for three engines, the Sulzer 1405 KW, the Superior 1500 KW and the Fairbanks Morse 1531 KW are shown in Table 3C-1.

The heat balances themselves for full and half-load are shown in Figures 3C-2 to 3C-6.

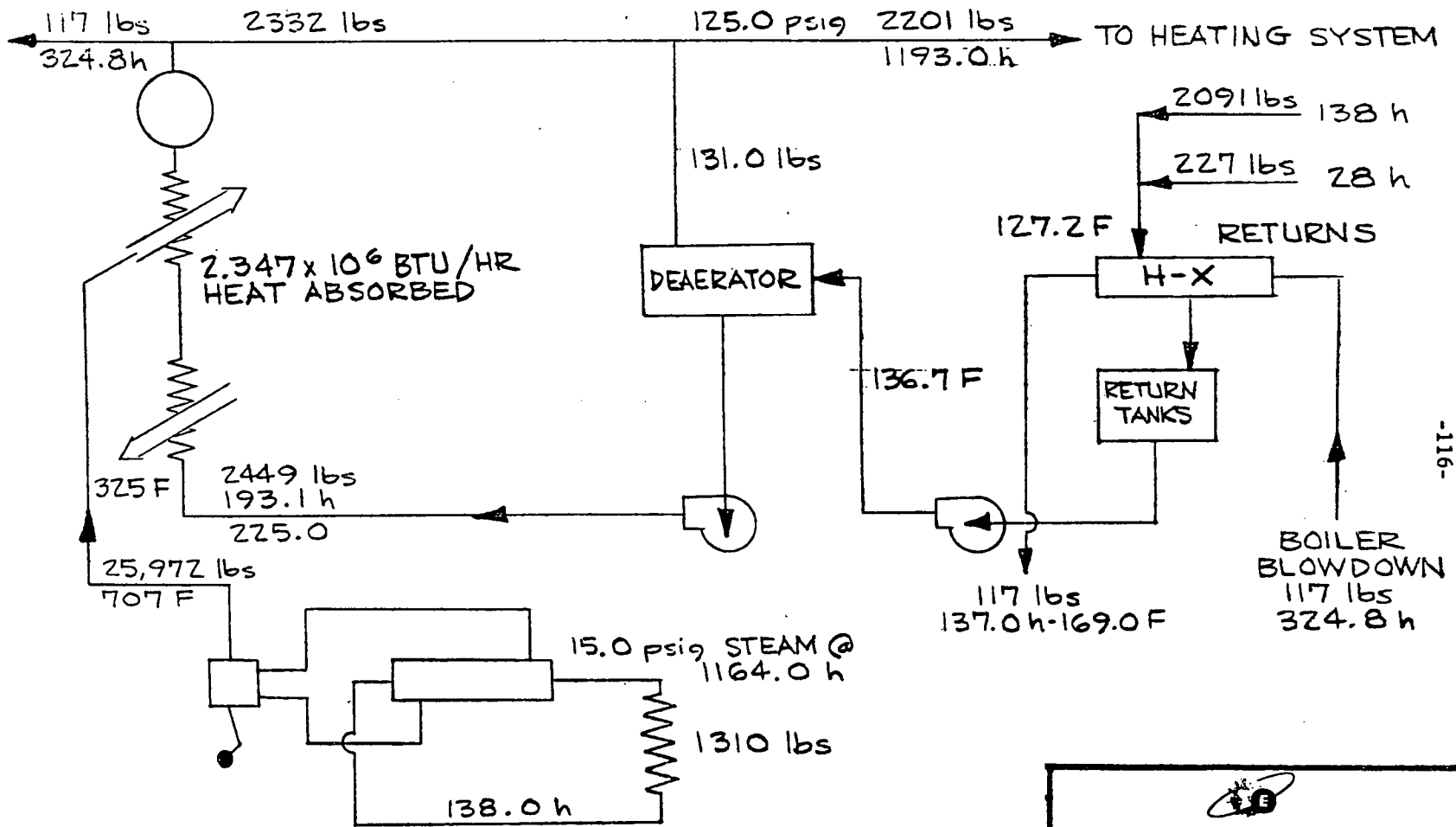

-116-

BASED ON 85 % EFFICIENCY BOILER

$$\text{HEAT RATE} = \frac{1984 \times .357 \times 18,924 - \frac{2201 \times 1193 - 2318 \times 127.2 + 1,343 \times 10^6}{0.85}}{1405.0} = 6466 \text{ BTU/KWH}$$

$$\text{FUEL COST} = 6466 \times \$2.50/10^6 = \$0.01617 / \text{KWH}$$

BASED ON 75 % EFFICIENCY BOILER

$$\text{HEAT RATE} = 6053 \text{ BTU/KWH}$$

$$\text{FUEL COST} = \$0.0151 / \text{KWH}$$

Figure 3C-2
Heat Balance: Sulzer 100% Load

THERMO ELECTRON ENGINEERING CORPORATION 85 FIRST AVENUE • WALTHAM, MASS. 02154		
DRAWN	CHECKED	ENGINEER
P. Greco	J. P. S.	
TITLE: CASE I - 100 % LOAD SULZER 8 CYL. MOD. ASL 25/30 1984 BHP - 900 RPM EKW = 1405		
SIZE	DRAWING NUMBER	SHEET REV
A		

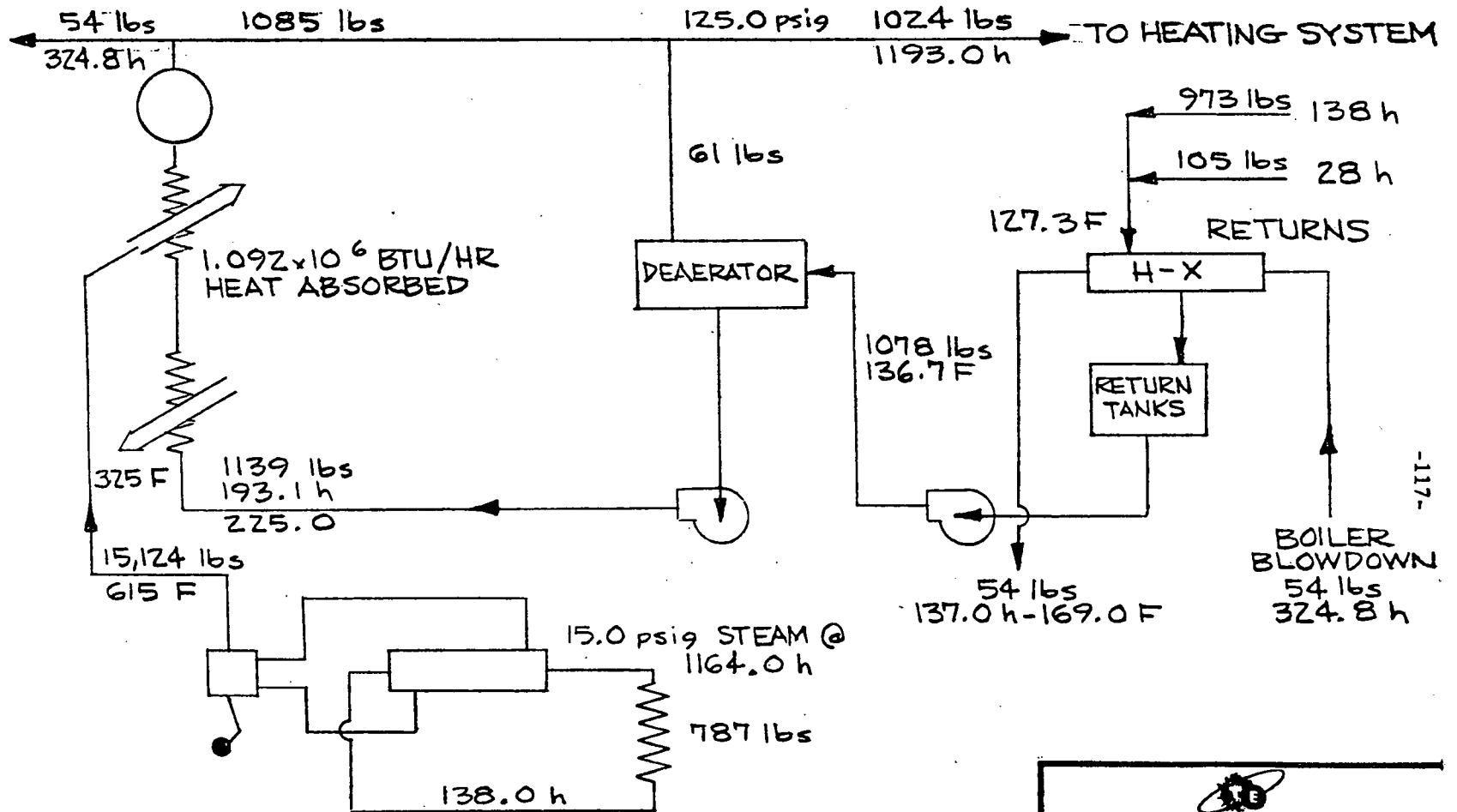

BASED ON 85 % EFFICIENCY BOILER

$$\text{HEAT RATE} = \frac{992 \times 371 \times 18,924 - \frac{687}{0.85} (1024 \times 1193 - 1078 \times 127.3 + .807 \times 10^6)}{687} = 6894 \text{ BTU/KWH}$$

$$\text{FUEL COST} = 6894 \times \$2.50 / 10^6 = \$.01724 / \text{KWH}$$

BASED ON 75 % EFFICIENCY BOILER

$$\text{HEAT RATE} = 6467 \text{ BTU/KWH}$$

$$\text{FUEL COST} = \$.01617 / \text{KWH}$$

Figure 3C-3
Heat Balance: Sulzer 50% Load

 THERMO ELECTRON ENGINEERING CORPORATION 88 FIRST AVENUE • WALTHAM, MASS. 02154		
DRAWN	CHECKED	ENGINEER
P. Greco	J. C. A.	
TITLE: CASE I 50 % LOAD SULZER 8 CYL. MOD. ASL 25/30 992 BHP - 900 RPM EKW = 687		
SIZE	DRAWING NUMBER	SHEET RE
A		

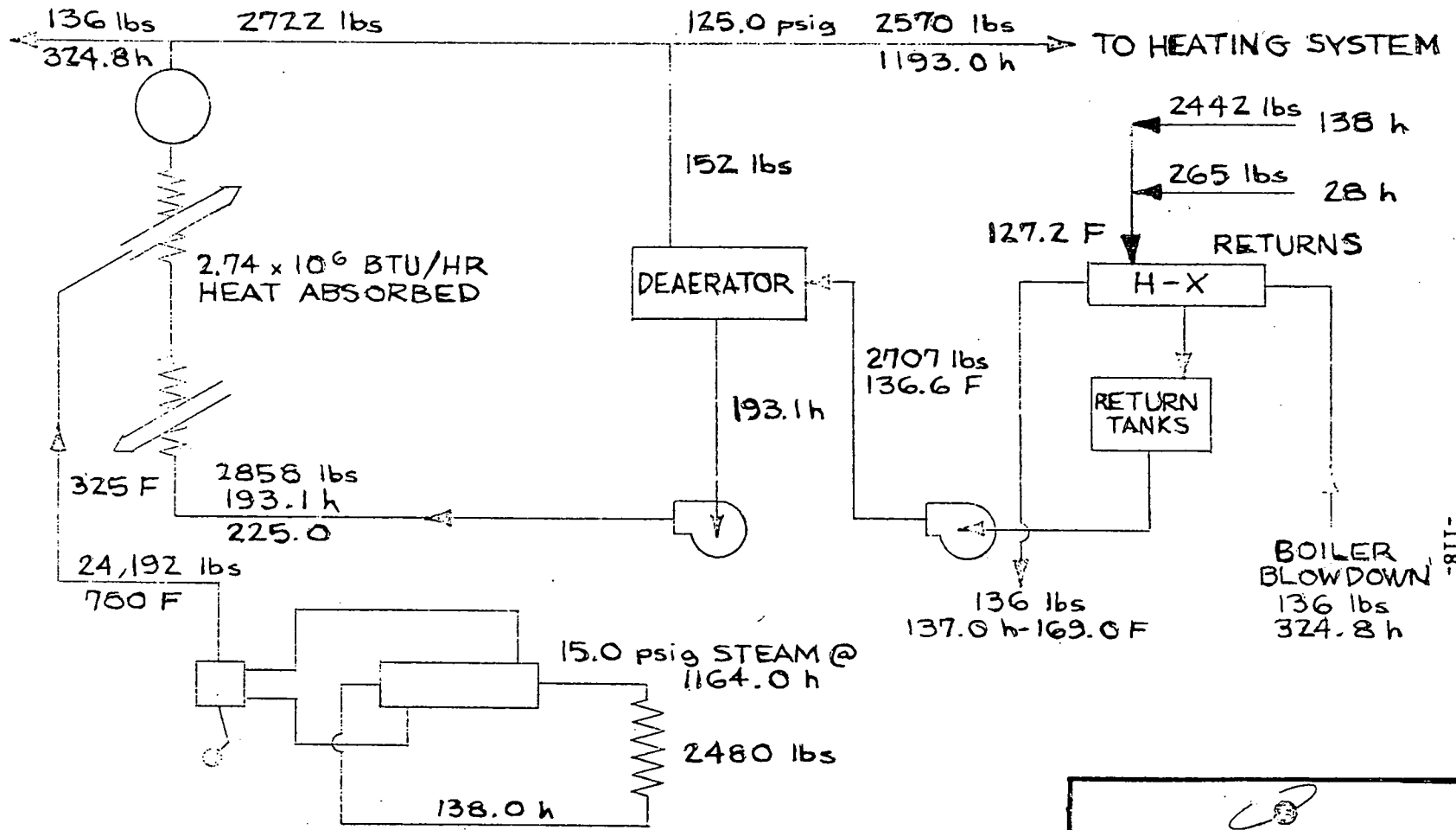

BASED ON 85 % EFFICIENCY BOILER

$$\text{HEAT RATE} = \frac{2120 \times .400 \times 18,924 - \frac{2570 \times 1193 - 2705 \times 127.2 + 24 \times 10^6}{1500}}{0.85} = 6681 \text{ BTU/KWH}$$

$$\text{FUEL COST} = 6681 \times \$2.50/10^6 = \$0.01670 / \text{KWH}$$

BASED ON 75 % EFFICIENCY BOILER

$$\text{HEAT RATE} = 6146 \text{ BTU/KWH}$$

$$\text{FUEL COST} = \$0.015364 / \text{KWH}$$

Figure 3C-4 Heat Balance: Superior, 100% Load

THERMO ELECTRON
ENGINEERING CORPORATION
85 FIRST AVENUE - WALTHAM, MASS. 02154

DRAWN	CHECKED	ENGINEER
R. Cole	J. L.	W. L.
TITLE: CASE II 100 % LOAD SUPERIOR 16 CYL. MOD. 40x1 2120 B.H.P. 900 RPM EKW = 1500		
SIZE: DRAWING NUMBER SHEET R. A		

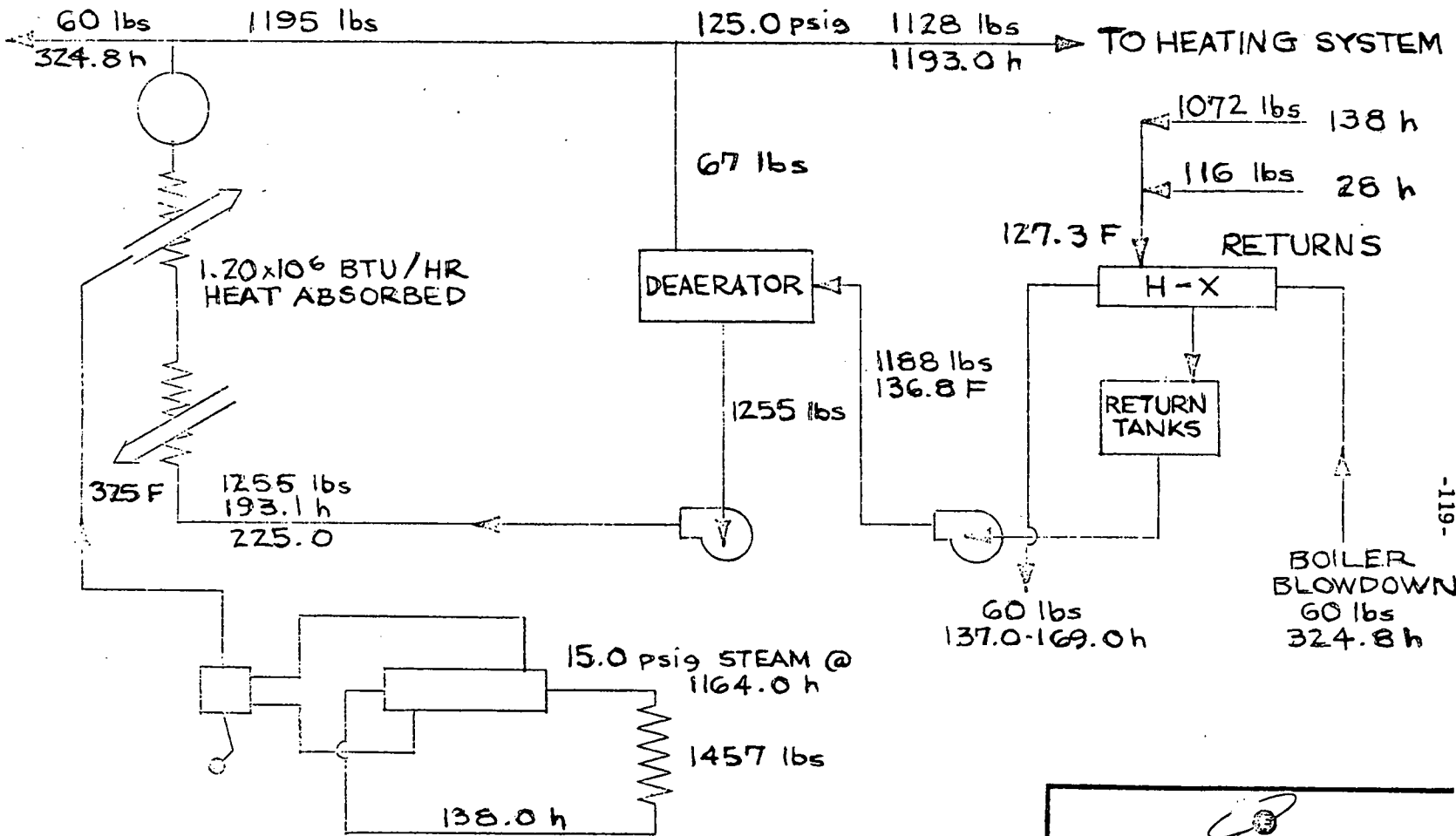

BASED ON 85 % EFFICIENCY BOILER

$$\text{HEAT RATE} = \frac{1083 \times 433 \times 18924 - \frac{1128 \times 1193 - 1188 \times 127.3 + 1495 \times 10^6}{0.85}}{750} = 7614 \text{ BTU/KWH}$$

$$\text{FUEL COST} = 7614 \times \$2.5/10^6 = \$0.01904/\text{KWH}$$

BASED ON 75 % EFFICIENCY BOILER

$$\text{HEAT RATE} = 7051 \text{ BTU/KWH}$$

Figure 3C-5

$$\text{FUEL COST} = \$0.01763/\text{KWH}$$

Heat Balance: Superior, 50% Load

 THERMO ELECTRON ENGINEERING CORPORATION 85 FIRST AVENUE • WALTHAM, MASS. 02154		
DRAWN	CHECKED	ENGINEER
P. Graco	J. C. Co.	J. W. Co.
TITLE: CASE II 50 % LOAD SUPERIOR 16 CYL. MOD. 40 x 16 1083 BHP, 900 RPM EKW = 750		
SIZE	DRAWING NUMBER	SHEET NO.
A		

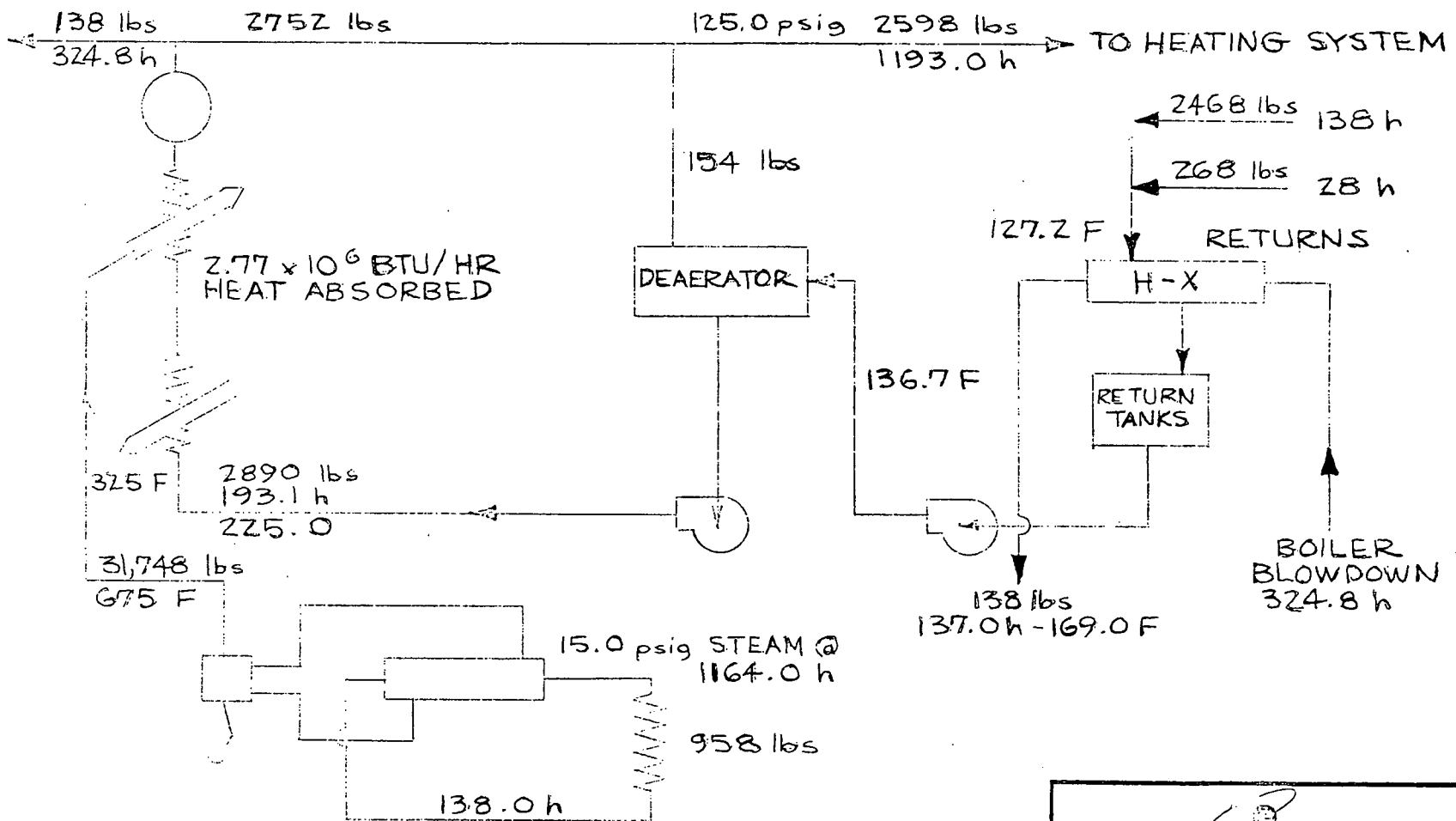

BASED ON 85 % EFFICIENCY BOILER

$$\text{HEAT RATE} = \frac{2160 \times 357 \times 18,924 - \frac{2598 \times 1193 - 2736 \times 127.2 + .983 \times 10^6}{0.85}}{1531} = 6662 \text{ BTU/KWH}$$

$$\text{FUEL COST} = \frac{2160 \times 357 \times 18,924 \times \$3.00/10^6 - \left[\frac{2598 \times 1193 - 2736 \times 127.2 + .983 \times 10^6}{0.85} \right] \times 2.5/10^6}{1531} = \$0.02142/\text{KWH}$$

BASED ON 75 % EFFICIENCY BOILER

$$\text{HEAT RATE} = 6279 \text{ BTU/KWH}$$

$$\text{FUEL COST} = \$0.02046/\text{KWH}$$

Figure 3C-6
Heat Balance: Fairbanks-Morse, 100% Load

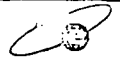
 THERMO ELECTRON ENGINEERING CORPORATION 85 FIRST AVENUE • WALTHAM, MASS. 02154		
DRAWN	CHECKED	ENGINEER
<i>D. G. ...</i>	<i>V. K. J.</i>	
TITLE: CASE III P.M.-O.P.-9 CYL. MOD. 25 TC 3 1/2 2100 BHP 1720 RPM ERW - 1531		
SIZE	DRAWING NUMBER	SHEET REV.
A		

APPENDIX 3D
Heavy Fuel Treatment System

APPENDIX 3D

Heavy Fuel Treatment System

The 120 GPM integrated heavy fuel treatment system can perform the following operations:

1. Heating the raw fuel.
2. Injection of demulsification agent.
3. Centrifugal desalting and sludge removal resulting in reductions of water-soluble metallic salts such as sodium, potassium, lead, calcium, etc.
4. Fuel management involving inhibition of vanadium via magnesium sulfonate, residual to distillate transfer capability, filtration and pumping.
5. All control and supervisory equipment for fully automatic operation of the entire system.

The system will reduce the sodium and vanadium content of the fuel as follows:

	<u>Influent Oil (representative values)</u>	<u>Effluent Oil</u>
Sodium	200 PPM	< 5 PPM
Vanadium	200 PPM	<30 PPM

Part of the sodium is water-soluble. Therefore, water (about 18 GPM) is first mixed with the fuel in a mixer. The fuel is then centrifuged. The single-stage centrifuge separates and removes water-soluble and nonsoluble sodium, potassium, lead, calcium and magnesium. The purifying effect of the centrifuge is dependent on the product of flow rate and the (kinematic) viscosity of the oil at the centrifuging temperature. This product must be small. The effluent is 99% water with the above metallic soluble plus approximately 1% oil. This oil is removed in a skimming tank where the oil content is reduced to less than 80 PPM.

After the centrifuging, the vanadium is treated. Organic vanadium is extremely corrosive in high-temperature areas of an engine. Because it is not very soluble in water, it is difficult to remove. Instead, it is made non-corrosive by combining it with magnesium prior to combustion in a ratio of a minimum of three parts of magnesium (by weight) to each part of vanadium (by weight). We will treat the vanadium with oil-soluble magnesium sulfonate. This chemical is available in the commercial product tretolite (KI-16) which is widely used in industry. Tretolite has 8% magnesium sulfonate and a

density of 9.25 lb/gal. See section 4B for cost analysis.

The following equipment modules will be required:

Centrifugal Desalting Skid consisting of:

- One solids ejecting centrifuge, capable of processing 120 GPH of the specified fuel.
- One (1) Mixer for blending fuel and water.
- One (1) Water system with pumping, heating and flow control.
- One (1) Heat exchanger for heating fuel complete with appropriate temperature controls.

Above skid will also include:

- Demulsifier system consisting of metering pump, level switch, gauge glass and calibrated metering glass.
- Inhibition system for appropriate addition of oil-soluble magnesium additive. Basis for design: 360 PPM vanadium, 3/1 Mg to V ratio.
- Controls consisting of starting circuits for all motors with appropriate termination points for easy interconnection to field terminals.

Fuel management skid consisting of a 100 gallon receiving tank for treated fuel, high-low controls and agitator.

The building must be properly ventilated and be equipped with an overhead crane providing access to all equipment.

The system flow diagram is shown on Figure 3D-1. Figure 3D-2 is a key drawing giving instrumentation symbols.

Utility Requirements:

1. Electrical power -- 208/3/60 - 13 KW
2. Air (instrument quality) -- 100 psig - 5 kg/cm²
3. Water (potable and less than 25 PPM Na+)
40 psig, 60°F with nominal flow capability of 12 GPH
4. Steam -- saturated 15 psig, approximately 60 lbs. per hour

Process Additives:

1. Demulsification agent:

Dosage	
Source	Nalco Chemical Company or Tretolite
Identification	Nalco 9-537DA or Tretolite RI-35

2. Inhibition of Vanadium:

Dosage	3.2/1 mg/Va
Source	Tretolite
Identification	Tretolite KI-16

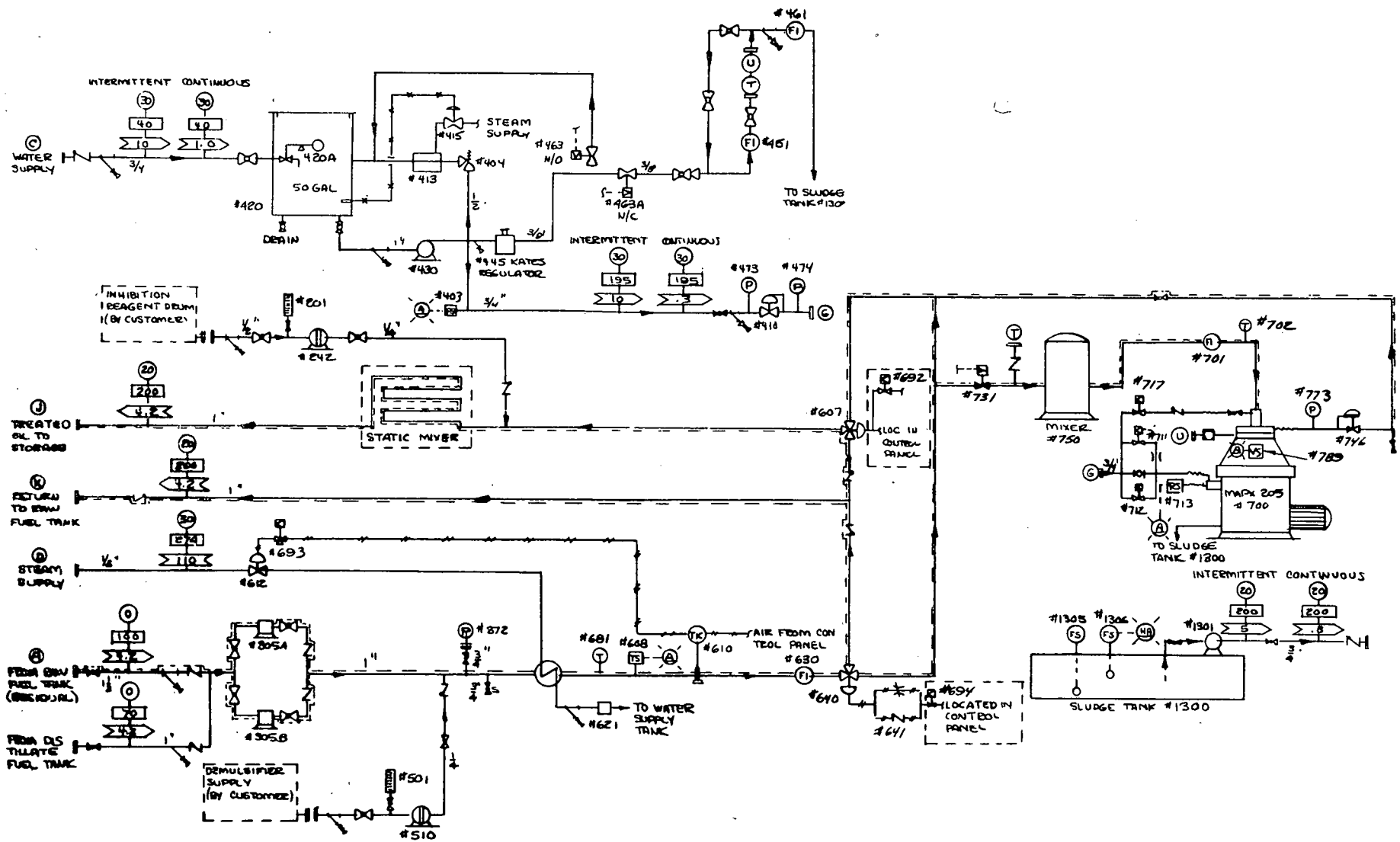

RESIDUAL FUEL OIL TREATMENT SYSTEM

	PROCESS LINE		FLASH BOTTOM TANK VALVE		REDUCER		MAGNETIC SEPARATOR		PANEL MOUNTED INSTRUMENT
	AUXILIARY LINE		2-WAY SANITARY VALVE, MANUAL OPERATED		RESISTOFLEX COUPLING		TRAP-CONDENSATE		VACUUM INDICATOR
	ELECTRICAL LINE		2-WAY SANITARY VALVE W/AIR ACTUATOR		DIAPHRAGM SEAL		SIGNAL CONVERTER		PRESSURE INDICATOR
	INSTRUMENT AIR LINE		3-WAY SANITARY DIVERT VALVE, MANUAL OPERATED		SIGHTGLASS		PUSHBUTTON		TEMPERATURE INDICATOR
	INSTRUMENT CAPILLARY LINE		3-WAY SANITARY DIVERT VALVE W/AIR ACTUATOR		FUNNEL		AIR SWITCH		LEVEL INDICATOR
	CLEAN IN PLACE LINE		SANITARY TEE VALVE, MANUAL OPERATED		SPRAY NOZZLE		PRESSURE SWITCH		FLOW INDICATOR
	STEAM TRACED LINE		SANITARY TEE VALVE W/AIR ACTUATOR		THERMOWELL		DIFFERENTIAL PRESSURE SWITCH		PRESSURE CONTROLLER
	JACKETED PIPE LINE		SELF DRAINING VACUUM VALVE		THERMOMETER W/WELL		LIMIT SWITCH		TEMPERATURE CONTROLLER
	FLOW DIRECTION ARROW		DIVERSION BALL VALVE		THERMOSTATIC AIR VENT		THERMAL SWITCH		CONDUCTIVITY CONTROLLER
	FLEXIBLE HOSE		FLOAT VALVE		ORIFICE		FLOW SWITCH		LEVEL CONTROLLER
	LINE STRAINER		AIR OPERATED KNIFE VALVE (GATE)		IN LINE RUPTURE DISC		FLOAT SWITCH		HAND INDICATING CONTROLLER
	BASKET STRAINER		SAUNDERS VALVE W/HANDWHEEL		RUPTURE DISC ON LINE OR NOZZLE		GREEN LIGHT		TEMPERATURE INDICATING CONTROLLER
	MANUAL CLEAN LINE FILTER		DIAPHRAGM VALVE		TANK VENT		DIAPHRAGM PUMP		CURRENT INDICATING CONTROLLER
	MOTORIZED LINE FILTER		PRESSURE REDUCING VALVE		ACCUMULATOR		TURBINE PUMP		HAND INDICATING CONTROLLER
	GATE VALVE		BACK PRESSURE VALVE		LINE BLIND		CENTRIFUGAL PUMP		FLOW RATIO RECORDING CONTROLLER
	SAMPLE VALVE, GATE		2-WAY SOLENOID VALVE		FIGURE 8 TYPE BLIND		POSITIVE PUMP		pH RECORDING CONTROLLER
	BALL VALVE		3-WAY SOLENOID VALVE		IN LINE MIXING TEE OR STEAM JET HEATER		POSITIVE PUMP W/VARIDRIVE		CONDUCTIVITY RECORDING CONTROLLER
	PNEUMATIC BALL VALVE		4-WAY SOLENOID VALVE		REVERSIBLE ELBOW - FLANGED		PROPORTIONING PUMP		FLOW RECORDER
	GLOBE VALVE		PRESSURE REGULATOR		REVERSIBLE ELBOW - CLAMPED		DESIGNED LINE TEMPERATURE		FLOW INDICATING CONTROLLER
	2-WAY PLUG VALVE		DUPLEX STRAINER VALVE INTEGRAL		CONDENSATE SEPARATOR		STEAM JACKETED		FLOW RECORDING CONTROLLER
	3-WAY PLUG VALVE		HAND VALVE W/LIMIT SWITCH		KATES FLOW REGULATOR		STEAM TRACED		LEVEL RECORDING CONTROLLER
	4-WAY PLUG VALVE				ALARM HORN				TEMPERATURE RECORDING CONTROLLER
	3-WAY TRANSFLO VALVE				ALARM BELL				PRESSURE RECORDING CONTROLLER
	CHECK VALVE				STEAM JET EJECTOR				PRESSURE TRANSMITTER
	NEEDLE VALVE				HEATER OR COOLER				TEMPERATURE TRANSMITTER
	RELIEF VALVE				SIPHON OR PIGTAIL				FLOW TRANSMITTER
	RELIEF VALVE W/HANDWHEEL OR HERMETIC CENTRIFUGE				TRANSDUCER				COMBINATION INSTRUMENT W/TWO SERVICES
	BACK PRESSURE VALVE				FLAME ARRESTER				LOW LEVEL INDICATOR
	ANGLE VALVE								HIGH LEVEL INDICATOR
	DAMPER VALVE								LOW LEVEL ALARM
	BUTTERFLY VALVE, MANUAL								HIGH LEVEL ALARM
	BUTTERFLY VALVE W/AIR CYLINDER								FLOW METER
	DIAPHRAGM CONTROL BUTTERFLY VALVE W/POSITIONER								
	DIAPHRAGM CONTROL VALVE W/POSITIONER								
	QUICK OPENING VALVE								

APPENDIX 4A

Detailed Capital Cost Analysis

We present here, in Tables 4A-1 and 4A-2, an update of the Phase I capital cost analysis. We have made the following important changes:

(1) We have computed costs for installation in a new building. (2) We have obtained costs for two new engines, the Sulzer and Superior. (3) We have made estimates, based on manufacturers' quotations, for the cost of a #6 oil fuel treatment system. (4) We have reviewed our previous cost estimates and made changes where necessary.

Our complete capital cost analysis is shown in Table 4A-1. The total costs for the Superior, Sulzer, and Fairbanks-Morse systems are about \$1,320,000, \$1,382,000, and \$1,187,000, respectively. It should be noted that these are costs to Clark; grid connection and special instrumentation will cost about an additional \$90,000.

Among the costs we reviewed were the engineering cost estimates. Our new estimate is shown in Table 4A-2. The engineering costs from final design on are expected to be around \$207,000. The grand total shown includes feasibility and preliminary design and is our estimate of the total engineering costs to another site duplicating the Clark system. The costs include engineering of the fuel treatment system. We expect the engineering of the #2-burning Fairbanks-Morse system to cost about \$7,000 less.

Table 4A-1

CAPITAL COST ANALYSIS INSIDE NEW BUILDING

MECHANICAL COSTS	Superior 1500 Kw Diesel Residual Oil Model 40-X-16	Sulzer 1405 Kw Diesel Residual Oil Model ASL 25/30	Colt F-M 1531 Kw Diesel Distillate Oil Model 38TD8-1/8
	<u>Total Cost</u>	<u>Total Cost</u>	<u>Total Cost</u>
Item No. 1 Engine and generator	\$ 385,411	\$ 444,704	\$ 438,000
2 Vibration isolation	3,375	3,375	3,375
3 No. 6 oil engine development	27,172	---	---
4 Switchgear	40,000	37,878	Included in Item 1
5 Skid and piping for engine and generator	---	30,000	---
6 Service platforms and rails	---	6,000	---
7 Control panel	---	8,000	---
8 Engine freight	5,000	2,500	5,000
9 Exhaust waste heat boiler and controls	63,900	54,766	54,766
10 Jacket ebullient boiler and controls	14,845	13,500	13,500
11 Jacket air cooled radiator, condenser and controls	12,035	10,350	10,350
12 Jacket circulating water pump	3,300	2,900	2,900
13 L.C. after cooler, and turbo cooler Glycol radiator with surge tank	6,440	5,500	5,500
14 Water softeners	4,000	4,000	4,000
15 Fuel oil treatment system	111,240	94,500	---
16 Air compressor for diesel starting and for instrumentation		7,000	7,000
17 Fire protection	10,000	10,000	10,000
18 Heating and ventilating including sound attenuation of fan penetrations. Floor and roof drains	\$ 25,000	\$ 25,000	\$ 25,000
19 Piping and hanger	40,000	40,000	40,000
20 Valves	20,000	20,000	20,000
21 Insulation	8,000	8,000	8,000
22 Intake filter		4,000	4,000
23 Intake silencer		5,700	5,700
24 Exhaust silencer	5,700	5,700	5,700
25 Diesel air inlet duct	5,000	5,000	5,000
26 Diesel exhaust gas duct	5,000	5,000	5,000
27 No. 6 F.O. day tank (600 gals.)		4,000	---
28 No. 2 F.O. day tank (300 gals.)	2,500	2,500	2,500
29 Fuel oil pumps	5,500	5,500	5,500
30 Sludge tank - 4000 gals.	4,000	4,000	---
TOTAL MECHANICAL	\$ 807,418	\$ 869,373	\$ 680,791

Table 4A-1

CAPITAL COST ANALYSIS INSIDE NEW BUILDING
(Continued)

Item No.	Superior 1500 Kw Diesel Residual Oil Model 40-X-16	Sulzer 1405 Kw Diesel Residual Oil Model ASL 25/30	Colt F-M 1531 Kw Diesel Distillate Oil Model 38TD8-1/8	
	<u>Total Cost</u>	<u>Total Cost</u>	<u>Total Cost</u>	
CIVIL WORK				
1.	New building - 37W x 60L x 24H including:			
a.	All foundations and exterior walls of brick and concrete block with unified proofed structural steel, bar joints and acoustical roof deck.			
b.	Foundations for engine-generator and auxiliary equipment.			
c.	An opening into the existing boiler room protected by a Class A sliding fire door.			
d.	14 x 14 sound proofed overhead door in the south wall.			
e.	An internal envelope of corrugated and perforated aluminum acoustical treatment on all walls and ceiling.			
f.	Crane having a span of 30' and 7 tons capacity.			
g.	95 foot brick stack.			
TOTAL CIVIL WORK	\$ 255,000	\$ 255,000	\$ 255,000	
ELECTRICAL WORK				
1.	Connections to generator set.	5,000	5,000	5,000
2.	Lighting for generator area, wiring for controls, pumps, heaters, ventilating system and motor control center.	25,000	25,000	25,000
3.	Underground four duct bank to the existing library distribution board.	<u>21,000</u>	<u>21,000</u>	<u>21,000</u>
TOTAL ELECTRICAL WORK	\$ 51,000	\$ 51,000	\$ 51,000	
TOTAL INSTALLED COST	\$1,113,418	\$1,175,373	\$ 986,791	
ENGINEERING COST TO CLARK (Final Design, Installation and Start-up)**	<u>207,000</u>	<u>207,000</u>	<u>200,000*</u>	
TOTAL PROJECT COST	\$1,320,418	\$1,382,373	\$1,186,791	

*For distillate fuel fired engine \$7,000 is subtracted from engineering costs because fuel treatment system not required.

**Refer to Table 4A-2.

TABLE 4A-2
Engineering Cost Analysis

	MAN MONTHS		
	Engineering	Design	Supervision
1.0 Engineering and economic feasibility	1.0		
2.0 Preliminary Design			
Detailed layouts	0.5	1.0	
Detailed cost analysis	0.7		
Grid connection	0.3		
Site and civil engineering	1.5	1.0	
Environmental engineering	0.8		
TOTAL	<u>3.8</u>	<u>2.0</u>	
3.0 Final Design			
General arrangement drawings	1.1	2.2	
Flow diagrams	1.1	2.5	
Electrical drawings and layout	1.0	2.0	
Thermal distribution system drawings and design	0.2	1.0	
Heating and ventilation drawings and design	0.4	.5	
Structural and accoustics drawings and designs	2.0	2.0	
Engine system specifications	1.9		
Electrical specifications	1.0		
Structural and accoustics specifications	2.0	1.4	
Heat and ventilation specifications	1.0		
Thermal distribution system specifications	1.0		
Project purchases, schedules and construction plan	2.0		
Construction cost budget	0.5		
TOTAL	<u>15.2</u>	<u>11.6</u>	
4.0 Installation			
Engine installation			1.7
Electrical installation			0.4
Civil and architectural installation			3.0
Heat and ventilation installation	.5		0.4
Thermal distribution installation			0.2
Drawing changes	0.5	1.0	0.2
TOTAL	<u>1.0</u>	<u>1.0</u>	<u>5.9</u>
5.0 Test and Startup	0.5		0.5
Sub Total (Final Design, Installation, Test and Start-up)	16.7	12.6	6.4
GRAND TOTAL	21.5	14.6	6.4
Sub Total Engineering Cost (Final design, Installation, Test and Start-up)		\$207,000	
GRAND TOTAL (Replication Engineering Costs)		\$247,000	

APPENDIX 4B
Operation and Maintenance Costs

APPENDIX 4B

Operation and Maintenance Costs

Operation and maintenance costs were estimated for the diesel engine, generator, boiler and accessory equipment. The estimates for the diesel engine were arrived at in consultation with representatives for Sulzer and Superior. Operation and maintenance costs for other equipment were estimated by Thermal Electron staff.

Sulzer reported that injectors should be removed and checked every 2000 hours and that this is an operation requiring 2 man hours. Their estimated lifetime is about 6000 hours. Annual checkups consisting of lifting the engine covers, checking valves, and pulling the pistons should be performed every 6000-8000 hours of operation. Cost for these annual checkups, including labor and replacement parts, (valves, lines, bearings, etc.) when required, amounts to about \$10-12/hp over the life of the engine. Expected lifetime of engine components is given in Table 4B-1 with estimated differences between distillate and residual oil use. Oil changes are recommended every 10-12,000 hours of operation. Sulzer recommended increasing the resultant costs by 25% to obtain a conservative estimate for operation on residual fuel.

Superior recommended checking the injector tips and changing the engine oil every 1000 hours, but claim that the injectors last 20,000 hours. They recommend periodic maintenance inspection periods consisting of engine observation and checks by field service mechanics every 2000 hours. They anticipate major overhaul periods every 20,000 hours. The major overhauls would include replacement of bearings, pistons, rings, and valves if required. Superior experience has been that the cost of the major overhauls for the worst case gas engines is about \$14-21/kwyr.

Both engines, Sulzer and Superior, require extensive fuel treatment of the residual oil. As explained in Appendix 3D, the two primary harmful impurities in the residual oil are vanadium and sodium. Both must be reduced to tolerable levels to insure proper engine operation and minimum maintenance costs. The sodium is removed by washing and centrifuging. The vanadium is treated with a magnesium-based compound to form magnesium ortho-vanadate¹ which has a higher melting point than organic vanadium.

¹ G.E. Krolls, Liquid Fuel Treatment Systems, General Electric Gas Turbine Reference Library, GER-2484, 1973.

TABLE 4B-1

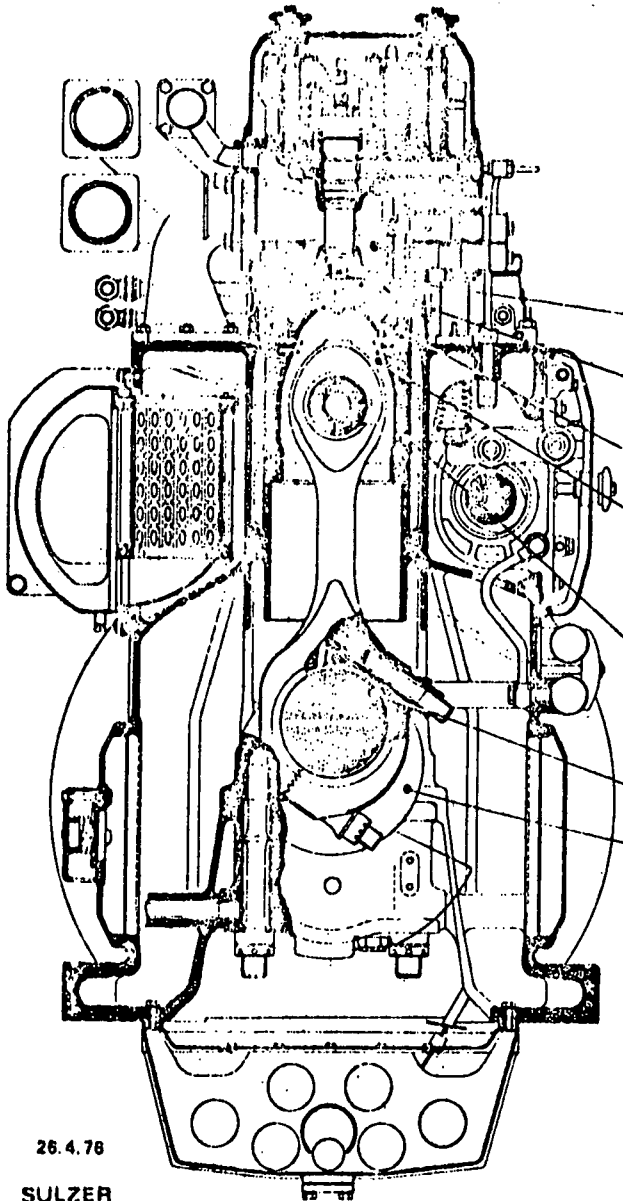

AL25/30 and AV25/30

Expected lifetime of engine components due to wear (load factor <0.9) [hrs]

	(Heavy fuel)	Diesel fuel
Injection nozzle:		above 6000
Valves:	(10000)	above 30000
Top piston ring:		10000-15000
Piston:		above 100000
Piston ring groove: Oversized		above 50000
Liner:		above 60000
Connecting rod bearings:		24000-48000
Main bearings:		32000-64000

Values depending on environment conditions and taking reconditioning possibilities into account

26.4.78

SULZER
0778 0032

This prevents deposition on the valves and cylinder walls. The amount of additive required depends on the content of the fuel and the amount that must be removed prior to use in the engine, amounting to about 3.2 parts of magnesium per part of vanadium (by weight) removed. Fuels available in New England have a wide range of vanadium content, from 50-250 PPM. For the purposes of this analysis we have assumed the vanadium content to be 150 PPM. Manufacturers' recommended limits on vanadium content going into the engine are listed in Table 4B-2. We see from this table that, according to manufacturer's experience, the Sulzer engine can tolerate greater limits on sodium and vanadium. Costs for neutralizing the vanadium are calculated in Table 4B-2, which shows that the cost of Tretolite KI-16 for the Superior engine is almost a mil/kwhr. greater than for the Sulzer engine.

Table 4B-3 summarizes the operation and maintenance costs for both the Sulzer and Superior engine based on the above discussion. We see from Table 4B-2 and 4B-3 that the difference is attributable to the larger amounts of fuel additive required by the Superior engine for removal of the vanadium. Other system operation and maintenance expenses are given in Table 4B-4. From this table we see that the operation and maintenance costs are 5.7 mils/kwhr for the Sulzer engine and 6.6 mils/kwhr for the Superior engine. This can be compared to an expected cost of about 4 mils/kwhr for the distillate-fired 1531 KW Fairbanks Morse with opposed piston described in the Phase I report.

TABLE 4B-2
 MANUFACTURERS' RECOMMENDED LIMITS
 FOR VANADIUM AND SODIUM GOING INTO ENGINE

	<u>Superior</u>	<u>Sulzer</u>
Vanadium	30 PPM	100 PPM
Sodium	5 PPM	<1/3 V content

Cost of Tretolite for Removal of Vanadium
 from 150 PPM to Limits Imposed by Manufacturers

Sulzer (150 PPM to 100 PPM)

$$\frac{50 \text{ lb V}}{10^6 \text{ lb fuel}} \times \frac{3.2 \text{ lb Mg}}{1 \text{ lb V}} \times \frac{100 \text{ lb tretolite}}{8 \text{ lb Mg}} \times \frac{\text{gal tretolite}}{9.25 \text{ lb tretolite}}$$

$$\times \frac{0.504 \text{ lb fuel}}{\text{kwhr}} \times \frac{\$5.00}{\text{gal tretolite}} = \$0.000545/\text{kwhr}$$

Superior (150 PPM to 30 PPM)

$$\frac{120 \text{ lb V}}{10^6 \text{ lb fuel}} \times \frac{3.2 \text{ lb Mg}}{1 \text{ lb V}} \times \frac{100 \text{ lb tretolite}}{8 \text{ lb Mg}} \times \frac{\text{gal tretolite}}{9.25 \text{ lb tretolite}}$$

$$\times \frac{0.565 \text{ lb fuel}}{\text{kwhr}} \times \frac{\$5.00}{\text{gal tretolite}} = \$0.00147/\text{kwhr}$$

TABLE 4B-3
SUMMARY OF DIESEL ENGINE OPERATION AND MAINTENANCE COSTS

	Sulzer Type 8 ASL 25/30 1405 kwe	Superior Model 40-X-16 1500 kwe
Injector Inspection and Replacement	\$ 1,300/yr	\$ 1,300/yr
Annual Maintenance and Overhaul (every 6-8000 hours)*	22,000	
Periodic Maintenance/Inspection**	2,200	2,200
Major Overhaul (every 20,000 hours)*		26,500
Oil	<u>8,000</u>	<u>6,000</u>
Sub Total	\$33,500/yr	\$36,000/yr
Sub Total x 1.25	41,900/yr	45,000/yr
Tretolite***	<u>5,400</u>	<u>15,400/yr</u>
Total Engine	\$47,300/yr	\$60,400/yr
Total Engine/kwhr	\$0.00481/kwhr	\$.000575/kwhr

*Includes major overhaul and replacement of all parts over 20 year life of engine.

**Includes oil analysis, replace filters, check fuel pumps, valves, crankcase, balance cylinder temperatures, etc.

***Based on vanadium content in oil of 150 PPM and treatment with tretolite (8% Mg) at 3.2 parts Mg/part V and \$5.00/gal tretolite.

TABLE 4B-4
SUMMARY OF SYSTEM OPERATION AND MAINTENANCE COSTS

	Sulzer Type 8 ASL 25/30 1405 kwe	Superior Model 40-X-16 1500 kwe
Diesel Engine (see Table C)	\$ 47,300/yr	\$ 60,400/yr
Generator	2,000	2,000
Boilers	1,600	1,600
Pumps	1,500	1,500
Fuel Treatment System	2,000	2,000
Miscellaneous	2,000	2,000
Total System	\$ 56,400/yr	\$ 69,500/yr
Total System/kwhr	\$0.00573/kwhr	\$0.00662/kwhr