

465
9/21/84 JRS (2)

DR-0420-0

JPL-PUB-83-88
(DE84014617)

Energy

S
O
L
A
R

ENVIRONMENTAL, HEALTH, AND SAFETY ASSESSMENT
OF PHOTOVOLTAICS

By
Elizabeth C. Rose

October 15, 1983

Work Performed Under Contract No. AC04-76DP00789

Jet Propulsion Laboratory
Pasadena, California

Technical Information Center
Office of Scientific and Technical Information
United States Department of Energy



DISCLAIMER

This report was prepared as an account of work sponsored by an agency of the United States Government. Neither the United States Government nor any agency Thereof, nor any of their employees, makes any warranty, express or implied, or assumes any legal liability or responsibility for the accuracy, completeness, or usefulness of any information, apparatus, product, or process disclosed, or represents that its use would not infringe privately owned rights. Reference herein to any specific commercial product, process, or service by trade name, trademark, manufacturer, or otherwise does not necessarily constitute or imply its endorsement, recommendation, or favoring by the United States Government or any agency thereof. The views and opinions of authors expressed herein do not necessarily state or reflect those of the United States Government or any agency thereof.

DISCLAIMER

Portions of this document may be illegible in electronic image products. Images are produced from the best available original document.

DISCLAIMER

This report was prepared as an account of work sponsored by an agency of the United States Government. Neither the United States Government nor any agency thereof, nor any of their employees, makes any warranty, express or implied, or assumes any legal liability or responsibility for the accuracy, completeness, or usefulness of any information, apparatus, product, or process disclosed, or represents that its use would not infringe privately owned rights. Reference herein to any specific commercial product, process, or service by trade name, trademark, manufacturer, or otherwise does not necessarily constitute or imply its endorsement, recommendation, or favoring by the United States Government or any agency thereof. The views and opinions of authors expressed herein do not necessarily state or reflect those of the United States Government or any agency thereof.

This report has been reproduced directly from the best available copy.

Available from the National Technical Information Service, U. S. Department of Commerce, Springfield, Virginia 22161.

Price: Printed Copy A04
Microfiche A01

Codes are used for pricing all publications. The code is determined by the number of pages in the publication. Information pertaining to the pricing codes can be found in the current issues of the following publications, which are generally available in most libraries: *Energy Research Abstracts (ERA)*; *Government Reports Announcements and Index (GRA and I)*; *Scientific and Technical Abstract Reports (STAR)*; and publication NTIS-PR-360 available from NTIS at the above address.

Environmental, Health, and Safety Assessment of Photovoltaics

Elizabeth C. Rose

October 15, 1983

Prepared for
Sandia National Laboratories
U.S. Department of Energy
Through an Agreement with
National Aeronautics and Space Administration
by
Jet Propulsion Laboratory
California Institute of Technology
Pasadena, California

THIS PAGE
WAS INTENTIONALLY
LEFT BLANK

ABSTRACT

Potential environmental, health, and safety (E,H&S) concerns associated with all phases of the photovoltaic (PV) energy system life cycle are identified and assessed. E,H&S concerns affecting the achievement of National PV Program goals or the viability of specific PV technologies are emphasized. The report is limited to near-term manufacturing process alternatives for crystalline silicon PV materials, addresses flat-plate and concentrator collector designs, and reviews system deployment in grid-connected, roof-mounted, residential and ground-mounted central-station applications. The PV life-cycle phases examined include silicon refinement and manufacture of PV collectors, system deployment, and decommissioning. The primary E,H&S concerns that arise during collector fabrication are associated with occupational exposure to materials of undetermined toxicity or to materials that are known to be hazardous, but for which process control technology may be inadequate. Stricter exposure standards are anticipated for some materials and may indicate a need for further control technology development. Minimizing electric shock hazards is a significant concern during system construction, operation and maintenance, and decommissioning.

ACKNOWLEDGMENTS

This report was prepared by Elizabeth C. Rose of the Systems Research and Technology Subprogram of the Photovoltaic Program's Technology Development and Applications (TD&A) Lead Center at the Jet Propulsion Laboratory (JPL), with support provided by the U.S. Department of Energy and Sandia National Laboratories through an agreement with the National Aeronautics and Space Administration.

The author thanks members of the Photovoltaics TD&A Lead Center, the Flat-Plate Solar Array Project, and the staff at JPL, especially Elisabeth J. Dutzi and Russell S. Sugimura, and to the staff at Sandia National Laboratories, Underwriters Laboratory, Inc., and Brookhaven National Laboratory for their invaluable assistance. Special thanks are extended to James R. Huning and Kent Volkmer at JPL, to Gary J. Jones at Sandia National Laboratories, and to Paul D. Moskowitz at Brookhaven National Laboratory.

Because the author is no longer affiliated with JPL,
all communication should be directed to
Kent Volkmer

CONTENTS

I.	INTRODUCTION	1
A.	RATIONALE	1
B.	SCOPE	2
C.	FORMAT	4
II.	SILICON REFINEMENT AND MODULE FABRICATION	5
	SUMMARY MATRIX	5
A.	SILICA MINING	8
B.	SILICON MATERIAL PRODUCTION	9
	1. Electric-Arc Furnace Silica Reduction Substep	9
	2. Semiconductor-Grade Silicon Refining Substep	10
C.	WAFER PRODUCTION	11
	1. Czochralski Ingot Method	11
	a. Single-Crystal Silicon Production Substep	11
	b. Ingot Wafering Substep	12
	2. Silicon Ribbon: Sheet Growth and Wafering	13
D.	WAFER SURFACE PREPARATION	14
	1. Acid Etch	14
	2. Alkali Etch	15
	3. Plasma Etch	16
E.	JUNCTION FORMATION	17
	1. Ion Implantation	18
	2. Gaseous Diffusion	19
	3. Liquid Dopant	19

F.	FRONT AND BACK SURFACE METALLIZATION	20
1.	Electroless/Electrolytic Plating	20
2.	Thick-Film Print	21
3.	Evaporation	22
G.	ANTIREFLECTIVE COATING	22
1.	Chemical Vapor Deposition	22
2.	Liquid Coating	23
3.	Evaporation	23
H.	ASSEMBLY OF FLAT-PLATE OR CONCENTRATOR MODULES	24
1.	Cell Interconnection Substep	24
2.	Encapsulation and Module Fabrication Substep	25
3.	Cell and Module Testing and Handling Substep	25
I.	NON-SILICON PHOTOVOLTAIC COLLECTOR MANUFACTURING	26
III.	RESIDENTIAL PHOTOVOLTAIC SYSTEM DEPLOYMENT	27
	SUMMARY MATRIX	27
A.	SYSTEM CONSTRUCTION	28
B.	SYSTEM OPERATION	30
IV.	CENTRAL-STATION SYSTEM DEPLOYMENT	33
	SUMMARY MATRIX	33
A.	SYSTEM CONSTRUCTION	33
B.	SYSTEM OPERATION	37
1.	Routine Operation	37
2.	Routine Maintenance	38
3.	Off-Normal Events Resulting in Fire	40

V.	SYSTEM DECOMMISSIONING	43
	SUMMARY MATRIX	43
	A. SYSTEM DISMANTLEMENT	43
	B. WASTE MANAGEMENT	44
VI.	POSTSCRIPT	47
VII.	GLOSSARY	49
VIII.	BIBLIOGRAPHY	53

Figures

1.	Photovoltaic Crystalline Silicon System Life Cycle: Typical Fabrication and Deployment Options	3
2.	Four Basic Array Mounting Schemes	29
3.	Central-Station Array Designs	35

Tables

1.	Environmental, Health, and Safety Concerns Associated with Typical Photovoltaic Crystalline Silicon Module Manufacturing Processes	5
2.	Environmental, Health, and Safety Concerns Associated with Roof-Mounted, Residential Photovoltaic System Deployment	27
3.	Environmental, Health, and Safety Concerns Associated with Ground-Mounted, Central-Station Photovoltaic System Deployment	34
4.	Environmental, Health, and Safety Concerns Associated with Residential and Central-Station Photovoltaic System Decommissioning	43

SECTION I

INTRODUCTION

A. RATIONALE

A major goal of the National Photovoltaics (PV) Program, U.S. Department of Energy (DOE), is to research and develop PV technology options that can be transferred to the private sector for further development, process optimization, and commercialization. For the near-term material option, crystalline silicon, that goal is well within reach. Lessons learned at the various national laboratories involved in PV research and technology development under the National PV Program can benefit the PV industry.

An element of the Program is the requirement that the DOE develop technological options that are environmentally sound, and that comply with all applicable regulations. The three main reasons for incorporating environmental, health, and safety (E,H&S) research at the earliest possible time are:

- (1) DOE is responsible under the National Environmental Policy Act (NEPA) to integrate environmental assessment activities at the earliest possible time in research and development programs [CEQ Regulations (40 CFR 1500-1598)]; NEPA integration is required to preclude potential litigation.
- (2) The cost of environmental compliance can be significantly reduced if environmental analyses are incorporated early into research and development, rather than being applied after technology development programs are in place.
- (3) Early and sufficient attention to environmental factors ensures that occupational and public health and safety are not jeopardized.

This document identifies and assesses potential E,H&S concerns associated with the life cycle of crystalline silicon residential and central-station PV systems. The document is intended to serve as a guideline for the Government and industry to help identify potential problem areas.

Early assessments of the developing PV technologies identified a variety of potential E,H&S concerns that have not been discussed in this report because they have been either resolved or determined to be insignificant as a result of programmatic research or advances in the technology. Only E,H&S issues having potentially significant technical or economic impact either on the viability of current PV manufacturing options or system applications are addressed in this report. Those areas in which a cost reduction in the process stream may be realized are noted, as are the many areas in which too little information exists to perform an adequate sensitivity analysis on potential process tradeoffs for environmental purposes. These may be prime targets for further investigation. The document also notes that current environmental regulations and legislative mandates can adversely affect the

development of PV technology if adequate E,H&S analyses are not incorporated as part of the system design process. Finally, those areas in which regulation is expected to be stricter in the future are identified. If standards are made stricter, process step selection and control technology availability or development may be affected.

All elements within the system life cycle are impacted to some degree by environmental regulations. Regulatory impacts upon PV technology developments range from requirements for the protection of worker health and safety during all phases of the PV life cycle under Occupational Safety and Health Act (OSHA) regulations, to requirements for the environmentally sound disposal of toxic or hazardous manufacturing wastes under Resource Conservation and Recovery Act (RCRA) regulations. OSHA and RCRA and their implementing regulations are two cost drivers which may significantly affect PV costs. Other statutes having an as yet undetermined regulatory impact on one or more phases of the PV system life cycle include the Clean Air Act (CAA), the Clean Water Act (CWA), the Hazardous Materials Transport Act (HMTA), and the Safe Drinking Water Act (SDWA).

B. SCOPE

This document identifies and assesses potential E,H&S concerns currently associated with the fabrication, deployment, and decommissioning of PV systems in terrestrial applications. The document is limited to crystalline silicon technologies, and it discusses the entire life cycle of residential and central-station PV systems: resource acquisition; cell and module fabrication; system deployment; system operation and maintenance; and system decommissioning. Both flat-plate and concentrator collector options are discussed. Figure 1 is a flow diagram of the PV system life-cycle phases addressed in this report (shaded titles), including typical silicon material production and PV module fabrication process options (listed vertically).

Material and process options still in the research phase are not addressed in detail in this report. These material and process options include, but are not limited to, thin-film technologies such as amorphous silicon, gallium arsenide, copper-indium diselenide, cadmium sulfide/copper sulfide, cadmium telluride, zinc phosphide, and a variety of other uncommon materials.

The report is also limited to the E,H&S concerns associated with grid-connected, roof-mounted, flat-plate residential systems and ground-mounted, fixed and tracking flat-plate and concentrator central-station systems. These two application areas serve to identify the primary E,H&S concerns associated with PV systems. Other PV applications such as remote systems of several hundred watts used to power ocean signal buoys, mountain-top radio and microwave repeaters, and water pumps in remote locations; intermediate systems of from 10 kilowatts to 1 megawatt suitable for commercial, multifamily residences; and institutional applications, must also address E,H&S considerations, but are outside the scope of this document.

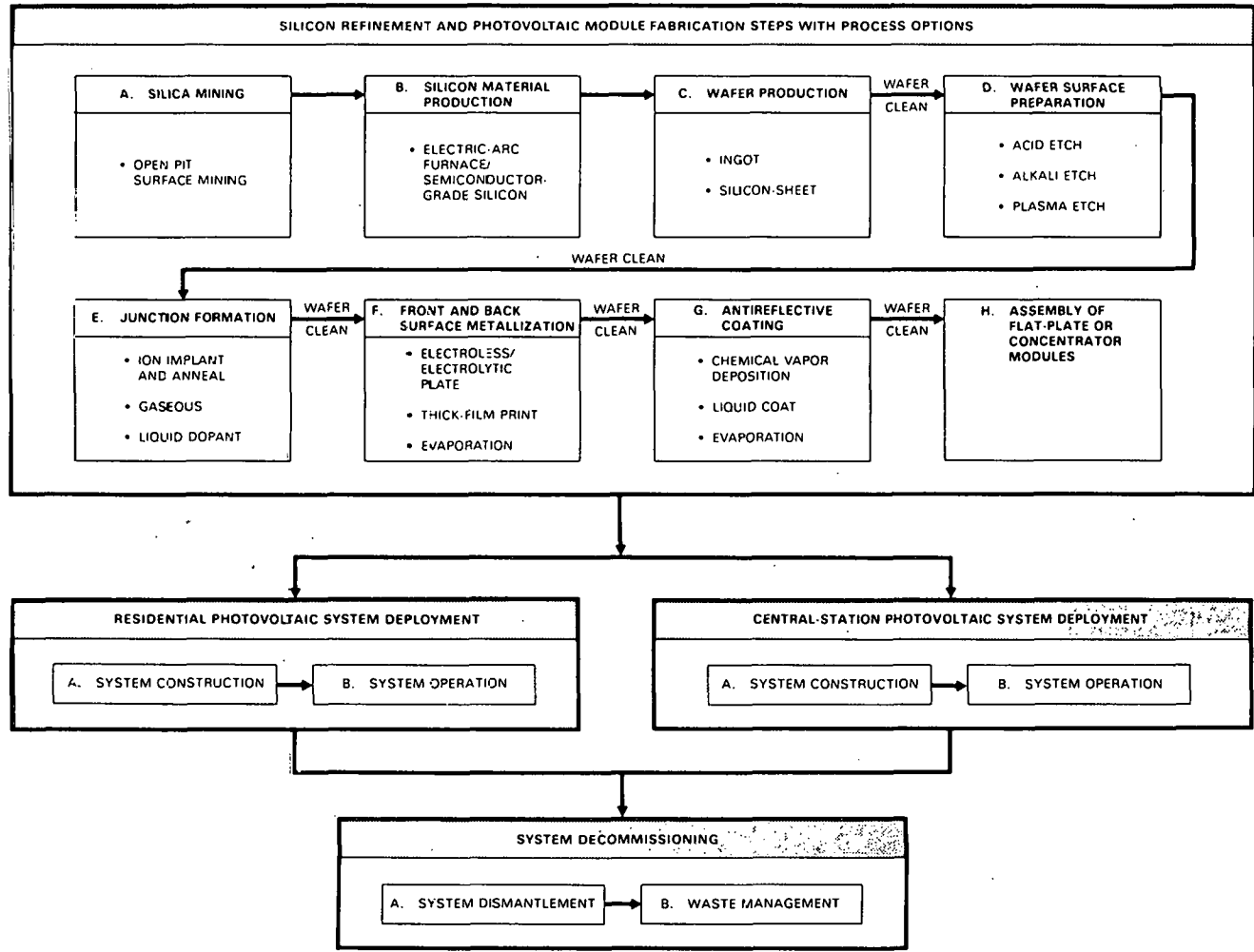

Figure 1. Photovoltaic Crystalline Silicon System Life Cycle: Typical Fabrication and Deployment Options

C. FORMAT

The four sections that follow discuss the major system phases of the PV life cycle: silicon refinement and module fabrication, residential system deployment, central-station system deployment, and system decommissioning. Following these four sections of the report are a postscript, a glossary, and a bibliography. Each section briefly describes the sequential activities that occur during the system phase, and identifies and assesses the E,H&S concerns associated with specific activities or processes. The section on module fabrication also addresses alternative module manufacturing options. Residential systems and central-station systems are the primary applications for finished modules. A summary matrix is presented at the beginning of each section for clarification and to provide an overview of the material that follows.

SECTION II

SILICON REFINEMENT AND MODULE FABRICATION

SUMMARY MATRIX

This section discusses E,H&S concerns associated with silicon refinement, PV cell manufacturing, and module fabrication. Table 1 summarizes individual generic process steps, identifies the E,H&S concerns associated with each step, and summarizes the assessment of those concerns. A generic sequence of process steps that lead from raw silica to finished PV modules includes silica mining, silicon material production, wafer production, wafer surface preparation, diffusion, metallization, antireflective coating, and module assembly.

Table 1. Environmental, Health, and Safety Concerns Associated with Typical Photovoltaic Crystalline Silicon Module Manufacturing Processes

Process Step	E,H&S Concern(s)	Assessment
A. Silica Mining	-Occupational exposure to silica	S
B. Silicon Material Production		
1. Electric-arc Furnace Reduction Substep	-Public and occupational exposure to Si particulates	S
2. Semiconductor-grade Silicon Refining Substep	-Occupational exposure to silane and chlorosilanes	S
C. Water Production		S
1. Czochralski Method		
a. Single-crystal Silicon Production Substep	-Health and environmental hazards from organic solvents	S
b. Ingot Wafering Substep	-Evolution of hydrogen from Si-slurry wastes	AT
2. Silicon Ribbon Sheet Growth and Wafering	-Occupational hazards from lasers	CA

Table 1. Environmental, Health, and Safety Concerns Associated with Typical Photovoltaic Crystalline Silicon Module Manufacturing Processes (Cont'd)

Process Step	E,H&S Concern(s)	Assessment
D. Wafer Surface Preparation		
1. Acid Etch	-Occupational exposure to acids	AP
	-Health and environmental hazards from acid wastes	S
2. Alkali Etch	-Occupational exposure to alkalis	AP
	-Health and environmental hazards from alkali wastes	CA
3. Plasma Etch	-Occupational exposure to uncharacterized plasma effluents	U
	-Occupational hazards from RF radiation	CA
E. Junction Formation		
1. Ion Implantation	-Occupational exposure to phosphorus	S, CI
	-Health and environmental hazards from organic solvents (applies also to 2. and 3.)	S
2. Gaseous Diffusion	-Occupational exposure to phosphorus	S, CI
3. Liquid Dopant	-Accidental occupational exposure to phosphorus	U
F. Metallization		
1. Electroless/Electrolytic Plating	-Health and environmental hazards from organic solvent wastes	S
	-Health and environmental hazards from plating wastes	CA

Table 1. Environmental, Health, and Safety Concerns Associated with Typical Photovoltaic Crystalline Silicon Module Manufacturing Processes (Cont'd)

Process Step	E,H&S Concern(s)	Assessment
2. Thick-Film Print	-Occupational exposure to metal inks	CI
3. Evaporation	-Potential occupational exposure to metal wastes	U
G. Antireflective Coating		
1. Chemical Vapor Deposition	-Occupational exposure to dichlorosilane	S
	-Occupational exposure to silicon nitride	U
2. Liquid Coating	-Insignificant	N/A
3. Evaporation	-Potential occupational exposure to metal wastes	U
H. Assembly		
1. Cell Interconnection Substep	-Occupational exposure to metal solders	CI
2. Encapsulation and Module Fabrication Substep	-Occupational exposure to encapsulant fumes	U
3. Cell/Module Testing and Handling Substep	-Occupational shock hazard from PV arrays	U
I. Non-silicon PV Collector Manufacturing	-E,H&S concerns are unassessed	U

Key: AP = Alternative processes are available; Cost-benefits undetermined
 AT = Alternative treatment methods are available; Cost-benefits undetermined
 CA = Current control technology is adequate
 CI = Current control technology is inadequate; Cost impacts undetermined
 NA = Not applicable
 S = Stricter standards anticipated; Cost impacts undetermined
 U = Toxicity, hazard, or safe exposure levels undetermined

A. SILICA MINING

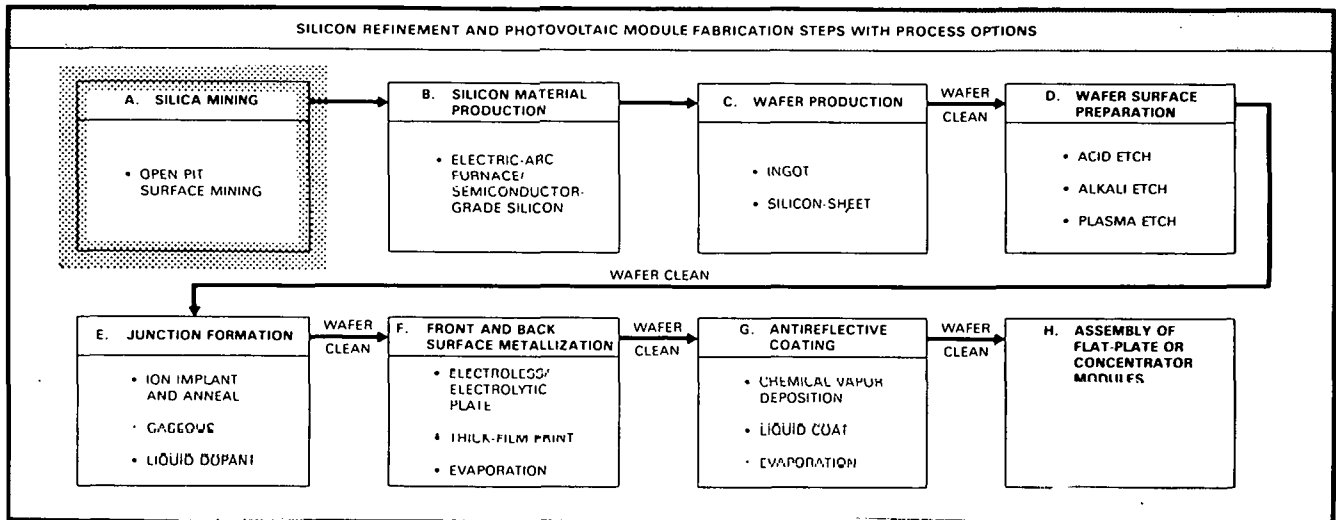

Silicon is produced from raw silica or quartzite, which is easily mined from shallow subsurface deposits. The E,H&S concerns associated with quartzite mining include land disruption, surface mining occupational injuries, and silicosis, a respiratory disease typically caused by chronic long-term exposure to silica dust.

E,H&S Concern: Occupational exposure to airborne silica via inhalation resulting in silicosis.

Assessment: Silicosis is a fibrotic lung disease caused by long-term exposure by inhalation to respirable (less than $5\ \mu\text{m}$) silicon dioxide particles. On-site dust control (e.g., by keeping the work area wet) and use of personnel protection equipment such as particulate-filtering can reduce worker exposure to silica. Silica mining attributable to PV manufacturing needs for a full gigawatt peak of modules, however, would constitute less than one half of 1% of the projected annual United States demand for silicon for the year 2000 (Bureau of Mines, 1979) [assuming $4\ \text{gm/W}_p$, 53% silica processing yield for ribbon wafers, and approximately 12% module efficiency at standard operating conditions (SOC)]. Therefore, the E,H&S concerns mentioned are not likely to have significant impact on the current or future PV industry.

B. SILICON MATERIAL PRODUCTION

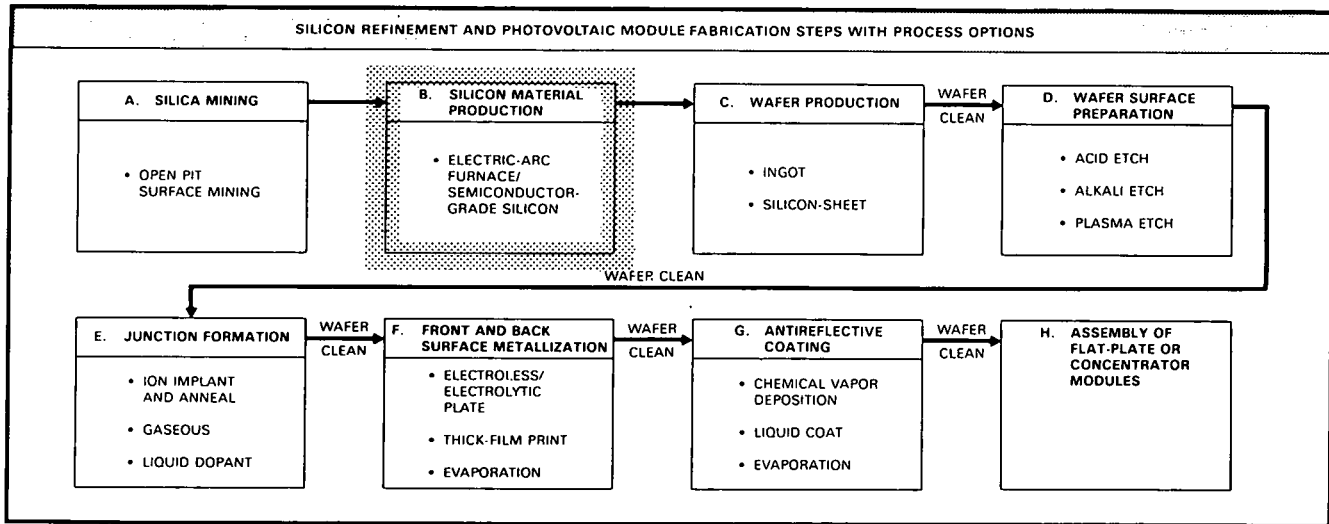

1. Electric-Arc Furnace Silica Reduction Substep

Silicon reduction and refinement begins with the crushing and cleaning of raw quartzite to form high-purity quartz chunks. The chunks are smelted in an electric-arc furnace with coke to produce metallurgical-grade silicon (MG-Si).

E,H&S Concern: Public and occupational exposure to airborne particulates from arc furnace silica reduction.

Assessment: Electric-arc furnace reduction of silica may expose the public and workers to airborne particulates of silica and fly ash that form when the vaporized silica emitted from the stack cools to form fine powders. These powders consist primarily of amorphous silica (SiO_2), which fall back into the work place or neighboring vicinity. To meet primary and secondary National Ambient Air Quality Standards (NAAQS), particulate emissions from silica refinement may be collected by bag-house or other filtering mechanisms; however, no specific emission standards exist for this industry. Because many particulates are submicron (0.1 to $4.0 \mu\text{m}$) (Vitruvs, et al., 1977), it is difficult to capture all particulate emissions. Average daily particulate concentrations of up to $875 \mu\text{g}/\text{m}^3$ have been measured in one work area (Gandel and Sears, 1977). To date, particulate emissions are well within allowable Clean Air Act ambient air quality and OSHA industrial hygiene standards. The current OSHA exposure standard for respirable crystalline silica is $10 \text{ mg}/\text{m}^3$ [Toxicity Limit Value (TLV)-Time Weighted Average (TWA) for a normal 8-hour workday or 40-hour workweek]. A new trial standard for respirable amorphous silicon has been set at $3 \text{ mg}/\text{m}^3$ [American Conference of Governmental Industrial Hygienists (ACGIH), 1982]. The National

Institute for Occupational Safety and Health (NIOSH) has recommended that the permissible exposure limit be changed to $50 \mu\text{g}/\text{m}^3$ (U.S. Department of Health and Human Services, 1978). With stricter emission standards, high-efficiency particulate emission controls, such as graduated filter bag-houses connected in series, will probably be required. Respiratory filters in the work area may also be required (U.S. Department of Health and Human Services, 1972). Pollution control equipment for electric-arc silica reduction has accounted for about 20% of capital costs and 10% of operating costs of new silica reduction plants. If stricter SiO_2 particulate standards are adopted, capital and operating costs for silica particulate control could nearly double (Bureau of Mines, 1981). Stricter silica particulate control requirements could impact material costs for the silicon-using technologies addressed within this document.

2. Semiconductor-Grade Silicon Refining Substep

In one process, MG-Si from the electric-arc furnace is reacted with concentrated hydrochloric acid (HCl) at high temperatures (approximately 1000 C) in a fluidized-bed reactor to form mono-, di-, tri-, and tetrachlorosilane (SiH_3Cl , SiH_2Cl_2 , SiHCl_3 , SiCl_4) feedstocks. The chlorosilane feedstock purified from MG-Si is converted primarily to liquid trichlorosilane (TCS) by condensation separation. TCS, purified by multiple distillation, is mixed with hydrogen and fed to a deposition chamber where polycrystalline silicon (poly-Si) is deposited on a silicon seed rod.

E,H&S Concern: Accidental occupational exposure to chlorosilanes via inhalation during chlorosilane production.

Assessment: Emissions of chlorosilanes can occur during silicon purification. Chlorosilanes react with moisture in the air to form HCl. HCl is highly corrosive, causes acute respiratory inflammation, and can severely damage eyes and skin in high concentrations or after prolonged exposure. If hydrogen-rich chlorosilanes predominate, a potential explosion hazard also exists. OSHA standards for exposure to both HCl and chlorosilanes is 5 ppm (parts per million) in air ($7 \text{ mg}/\text{m}^3$) (U.S. Department of Health and Human Services, 1978). Measurements in the silicon purification workplace have indicated chlorosilane levels below 1 ppm in air (Owens, et al., 1980). Under normal working conditions, exposure to chlorosilanes is not expected to be a significant concern. A chlorosilane leak, however, may rapidly result in explosive ambient concentrations. Because of the volatility of certain chlorosilanes, current OSHA safety standards are considered inadequate (SEMI, Inc., 1982). Standards are likely to become stricter in the future, which means that additional controls and monitoring may be required. Associated cost impacts are undetermined.

In a new refining method, MG-Si is converted to gaseous TCS in a hot, copper-catalyzed, fluidized-bed reactor. Non-volatile metal-chloride contaminants are drawn off at the dew point, and hydrogen is separated as a non-condensable gas from the condensed crude TCS. The crude TCS is stripped of dissolved volatile impurities in a stripping column. After a series of conventional distillation columns and redistribution reactors, hydrogen-rich silane (SiH₄) liquid results.

Following distillation and redistribution, silane is pyrolyzed to remove the hydrogen gas. Most hydrogen is recycled, but it may be burned. Pyrolysis leaves a high-purity silicon metal powder that is consolidated by melting to remove it from the process. Current control technology is adequate to meet hydrogen and silicon metal particulate standards (Owens, et al., 1980). Standards are not expected to change in the near-term (ACGIH, 1982).

E,H&S Concern: Occupational exposure to silane via inhalation.

Assessment: Silane is toxic and highly volatile. Trial exposure standards have only recently been established (ACGIH, 1982). The adequacy of these standards is now under study (SEMI, Inc., 1982). Silane is being studied by the ACGIH to determine safe occupational exposure limits (ACGIH, 1982). Additional process controls and monitoring will be required if new and stricter standards are adopted. Cost impacts resulting from stricter standards are undetermined.

C. WAFER PRODUCTION

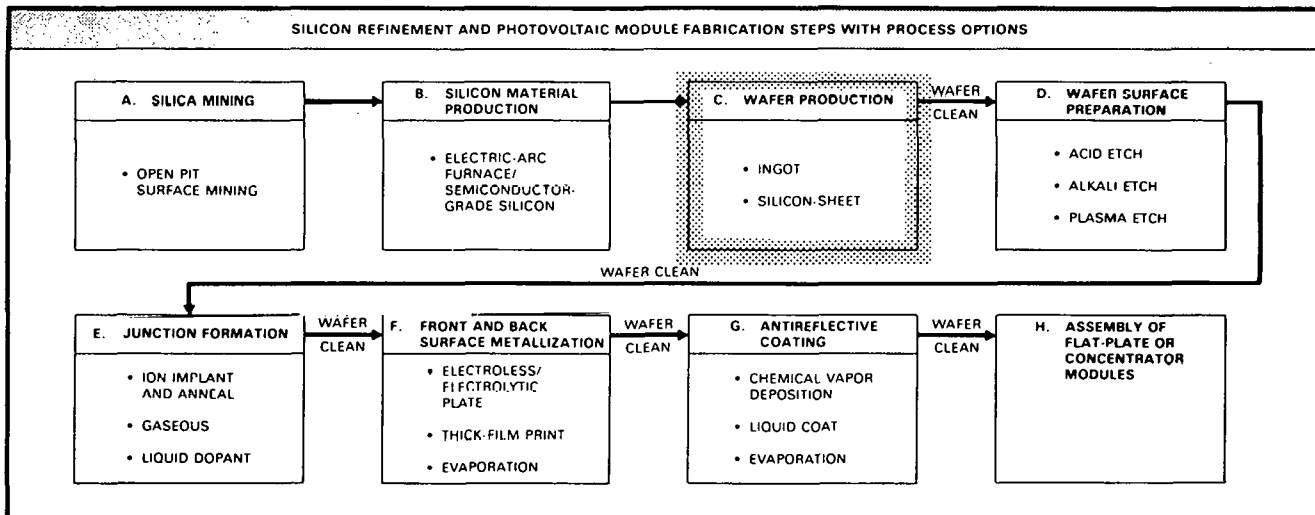

1. Czochralski Ingot Method

a. Single-Crystal Silicon Production Substep. Semiconductor-grade silicon (SG-Si) is crushed and a dopant, usually boron, is added. It is then placed in a quartz crucible where it is melted and a seed silicon crystal is

introduced. In an argon or helium atmosphere, a single-crystal SG-Si ingot is slowly pulled from the crucible. Ingot-growing equipment is periodically cleaned with solvents.

E,H&S Concern: Health and environmental hazards from improper use and disposal of organic solvents.

Assessment: Most organic solvents are flammable and are toxic to humans, animals, and plants. Wastes improperly disposed of can contaminate ground water and drinking water. Some solvents are suspected human carcinogens; their presence in contaminated drinking water supplies is a significant health concern (U.S. Department of Health and Human Services, 1978). Wastes improperly discarded are also a significant fire hazard. Toxic waste fires not only present immediate dangers of heat and smoke, but can also spread harmful particles over wide areas. Diffusion and metallization involve the use of large quantities of solvent-based materials for applying, developing, and stripping photoresist and mask materials (California Department of Industrial Relations, 1981). Solvents typically used to remove surface wastes include acetone, toluene, trichloroethylene, and xylene. These chemicals are commonly used in the semiconductor and PV industries as solvents and degreasers, and are used to clean equipment as well as the prepared wafers. New and stricter OSHA standards have recently been adopted for acetone (reduced from 1000 to 750 ppm) and trichloroethylene (reduced from 100 to 50 ppm) (ACGIH, 1982; U.S. Department of Health and Human Services, 1978). Standards for xylene and toluene stand at 100 ppm; they are easily met with existing control technologies. The solvents, however, are considered either toxic or hazardous under RCRA (see RCRA wastes in glossary for EPA definitions of waste classifications). In addition, because they are flammable liquids, they may no longer be disposed of in Class I landfills, but must be incinerated or permanently destroyed by some other method (RCRA, U.S.C. 42, amended 1980). Incineration is a very costly procedure, especially if the wastes are contaminated with toxic metals. Incineration costs range from \$250 to \$500 per ton and may cost in excess of \$1000 per ton for highly toxic phosphorus-contaminated compounds (California Toxic Waste Assessment Group, 1981). Complete implementation of this new RCRA requirement is expected to further increase the control costs associated with solvent use. Cost impacts associated with solvent control requirements, treatment, and disposal are undetermined.

b. Ingot Wafering Substep. Prior to wafering, the tapered ends of the ingot are trimmed, and it is then ground to the desired diameter. Silicon wafers are sliced from the ingot either by a multiblade slurry saw or an inside-diameter diamond blade saw.

E,H&S Concern: Slurry wastes may evolve small amounts of explosive hydrogen gas and cannot be handled by conventional methods.

Assessment: Saw and ingot-trimming wastes constitute approximately one-half of the original high-purity silicon input to the ingot process. Only about one-third of this waste--the trimmed ends--can be recycled within the process. Slicing ingots with an abrasive slurry generate a sludge consisting of oils, clay, adhesives, solvents, alumina, silicon carbide, and steel (Gandel and Sears, 1977).

When allowed to stand in a confined area, hydrogen gas evolving from the waste sludge can accumulate to a dangerous concentration (SSD, 1982). Several slurry pipe explosions occurred before this problem was recognized. Materials that produce explosive gases are classified as ignitable by RCRA and must be disposed of in a secure landfill. Representative costs of disposal for non-toxic RCRA solid wastes in California are about \$30 per ton (BKK, 1983; Kettleman, 1983), and these do not include transportation or additional treatment. If the hydrogen gas or gas-producing reactants are removed from the sludge, however, it is not classified as ignitable and may be disposed of in an ordinary landfill, or it may be safely recycled to industries that do not require high-purity silicon, e.g., the steel industry. Current California landfill disposal fees for non-hazardous wastes are about \$4 per ton (Los Angeles Sanitation District, 1983). Hydrogen-gas producing reactants can be removed from the saw sludge by rinsing it twice with water. Ingot slicing produces approximately 1 gallon of abrasive slurry per wafer (Chamberlain, et al., 1980). Sludge rinsing could potentially double the volume of liquid/sludge saw wastes which still must be handled and treated. An alternative to sludge rinsing, but of undetermined feasibility, is to convey the sludge from the process area on open conveyors and dry it in evaporative ponds, or dry it by land spreading prior to landfill disposal. Land spreading costs approximately \$6 per ton (U.S. Environmental Protection Agency, 1979).

2. Silicon Ribbon: Sheet Growth and Wafering

Silicon ribbon sheet methods of wafer production are relatively new. Silicon ribbon sheets are pulled from liquid silicon by several processes including edge-defined film-fed growth and dendritic-web growth. The silicon sheets are laser-scribed and cut to form individual wafers. No process emissions are produced in this phase (Owens, et al., 1980). If a laser is used to cut or scribe the silicon sheets, workers must wear eye protection equipment. Two advantages of sheet ribbon wafer production over ingot wafer production are that none of the valuable silicon is lost as saw waste, and that there are no significant associated effluent treatment disposal requirements or sludge-related E,H&S concerns.

E,H&S Concern: Occupational exposure to physical hazards associated with lasers.

Assessment: Lasers produce intense, concentrated beams of light that can cause burns and eye injuries. Use of available process shielding and personnel protection equipment such as goggles and face masks can significantly reduce worker exposure to this physical hazard (National Council on Radiation Protection and Measurements, 1971). Occupational injuries caused by lasers are not expected to be a significant safety problem for this process (Owens, et al., 1980).

D. WAFER SURFACE PREPARATION

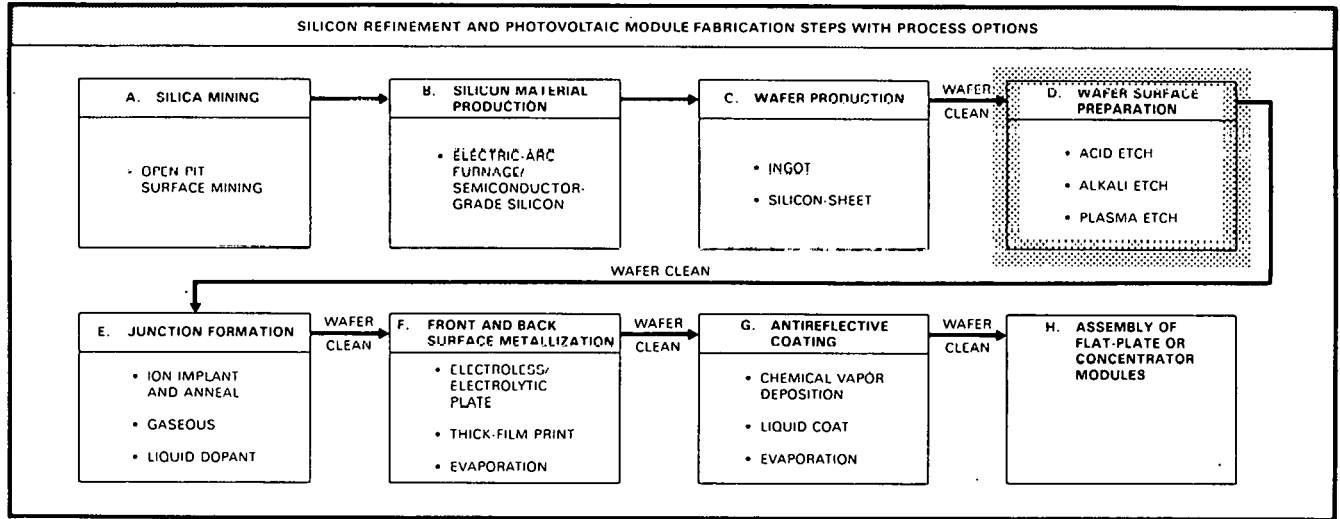

The raw silicon wafer must be cleaned and etched to remove oxidized silicon, to remove saw damage (for ingot wafers), and to prepare the wafer for further processing. Wafers may be "wet etched" with concentrated acid or alkali solutions, or "dry etched" with gaseous plasma.

1. Acid Etch

In the acid etch process, hot, concentrated hydrofluoric or a hydrofluoric/nitric acid (HF/HNO₃) solution is used to prepare the wafer surface. Plastic cassettes containing the wafers are currently manually loaded into the etch tank. This process produces liquid-acid wastes and corrosive silicon tetrafluoride (SiF₄) and hydrofluoric acid gases.

E,H&S Concern: Accidental occupational exposure via skin and/or eye contact with acid etchants.

Assessment: Acid burn hazards from hydrofluoric acid during the transfer of wafers to and from hot acid baths are significant safety concerns. Hydrofluoric acid is extremely corrosive and it is not easily washed off the skin. It continues to corrode until diluted within the exposed tissue or neutralized by calcium in bone. Acid burn hazards may be minimized by use of tank shields and protective clothing. However,

process automation would eliminate this worker-process interface and any costs associated with acid injury and protective equipment as well. Corrosive gas emissions are controllable and may be kept well within allowable standards with available acid fume control equipment. Cost impacts associated with automated versus non-automated etching processes are undetermined.

E,H&S Concern: Health and environmental hazards from improper acid waste disposal.

Assessment: Improper disposal of acid wastes can cause acid burn hazards to the public, contaminate drinking water supplies, and lower soil and water pH or change their natural chemistry so they cannot support life. Acid wastes constitute one of the largest liquid effluent streams in the semiconductor and PV component manufacturing industries (Coleman, et al., 1981; Moskowitz, et al., 1980). According to RCRA requirements, all concentrated acids must be neutralized prior to final disposal. In addition to neutralization, fluorides must be removed by precipitation with lime (CaO) for separate disposal as calcium fluoride (CaF₂). Neutralization and chemical precipitation costs range from \$50 to \$350 per ton in California, depending upon the degree of contamination by heavy metals (California Toxic Waste Assessment Group, 1981). Although no OSHA, CWA, or RCRA standards exist for calcium fluoride, local water treatment municipalities are generally imposing stricter standards on the amount of any fluoride compounds allowable in industrial waste water because they can poison biological treatment systems (Cartwright, 1982). Therefore, increased acid treatment costs may be anticipated for most locations in the near future. Cost impacts of local water treatment requirements for California's "Silicon Valley" and other major locations for the semiconductor industry are undetermined.

2. Alkali Etch

In the alkali etch process, concentrated sodium hydroxide (NaOH) is used to prepare the wafer surface. As in the acid etch process, cassettes of wafers are manually loaded into the etch tank.

E,H&S Concern: Accidental occupational exposure via skin and/or eye contact with alkali etchants.

Assessment: Alkali burn hazards from concentrated sodium hydroxide are significant safety concerns. Concentrated alkaline solutions are more corrosive than most inorganic acids, e.g., nitric or sulfuric acids. Strong alkalis gelatinize tissue forming soluble compounds, thereby producing deep, painful burns. An insidious hazard associated with alkali burns is that initial contact may not be painful; therefore, severe damage may occur before the victim becomes aware of the exposure. As with acid etchants, alkali burn hazards may be minimized,

although not eliminated, by use of tank shields and protective clothing. Process automation would reduce alkali etchants as a safety concern. Cost impacts associated with automated versus non-automated etching processes are undetermined.

E,H&S Concern: Health and environmental hazards from improper alkali waste disposal.

Assessment: As with improper acid disposal, improper disposal of alkali wastes can cause alkali burn hazards to the public, contaminate drinking water supplies, and change natural soil and water chemistry by raising the pH to a level where life cannot be supported. According to RCRA requirements, all concentrated alkalies must be neutralized prior to final disposal. Alkali treatment and disposal may ultimately cost less than treatment and disposal of an equivalent volume of acids because alkalies may be sold for the purpose of acid neutralization (Gallagher, 1983). Acids may also be sold for reuse. However, industrial processes in general tend to use more acids than alkalies. Therefore, there are more acids that must be neutralized than there are spent alkali solutions to neutralize them. Consequently, alkali etchants may be preferable to acid etchants because there typically is an existing market to receive spent alkali wastes in most industrial locations. Alkali waste treatment and disposal costs are comparable to acid waste treatment costs, but they vary depending upon the degree of contamination by heavy metals (California Toxic Waste Assessment Group, 1981).

3. Plasma Etch

Plasma etching, a so-called "dry-etch" process, is a new material-saving alternative to wet-acid/alkali etching. Wafers are etched with carbon tetrafluoride (CF_4) plasma in a vacuum chamber. The plasma reacts with oxidized silicon to form volatile reaction products that are removed by a vacuum pump. An advantage of this process over wet etching is that it is easily automated and eliminates the E,H&S concerns and costs associated with treatment and disposal of liquid etchant waste streams. Plasma etching is a relatively new process and the composition and toxicity of associated process effluents have not yet been determined.

E,H&S Concern: Potential occupational exposure via inhalation or other contact with plasma effluent stream.

Assessment: Plasma etchant effluents are primarily volatile reaction products. The volatile products may include silicon tetrafluoride (SiF_4), silicon fluoride radicals (SiF_x), silicon oxyfluoride compounds ($SiOF_2$, Si_2OF_6), oxygen (O_2), fluorine (F_2), and carbon dioxide (CO_2) (Owens, et al., 1980; California Department of Industrial Relations, 1981). Some effluent species, particularly silicon fluoride radicals, may prove toxic at low exposure levels because they are highly reactive (Patty, 1979). In addition, no OSHA standards

exist for occupational exposure to silicon fluorides or silicon oxyfluorides. If toxicity is demonstrated, occupational exposure standards may be established. Control technology requirements and costs associated with this process cannot be determined until the waste stream has been characterized and relative toxicity of its constituent chemical compounds determined with respect to industrial hygiene guidelines.

E,H&S Concern: Occupational exposure to physical hazards from RF radiation.

Assessment: Plasma used in plasma etching is generated with a RF power source. Occupational exposure to RF radiation is possible, although the likelihood of such exposures occurring during this process has not been determined (Moskowitz, et al., 1982). Little is known about the effects of RF radiation on humans, but results from animal studies indicate that a variety of changes in physical, nervous, and reproductive systems may be caused by exposure to RF radiation (U.S. Department of Health, Education, and Welfare, 1979). The power source used for plasma etching, however, is typically below the standard set by OSHA for occupational exposure to this physical hazard (Owens, et al., 1980). Thus, occupational injuries caused by exposure to RF radiation from this process are not expected to be a significant health or safety problem.

E. JUNCTION FORMATION

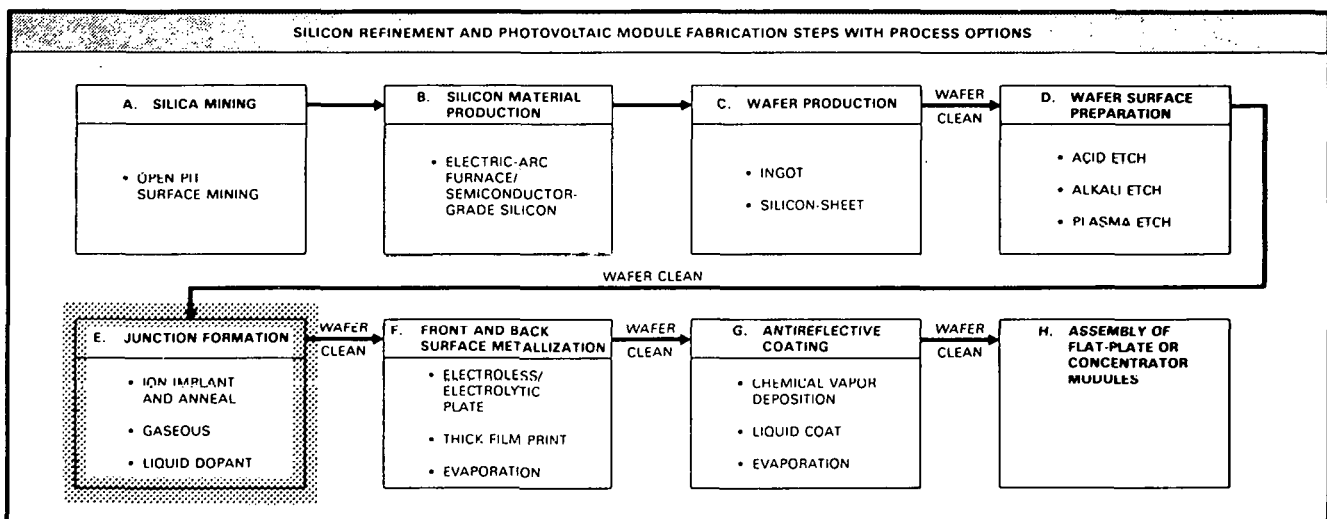

The junction formation process creates the p-n junction within the silicon crystal, enabling the cell to produce electricity. Junction formation is typically performed by one of three methods: ion implantation, gaseous diffusion, or liquid (polymer) dopant.

1. Ion Implantation

Phosphorus dopant ions from a gaseous compound (PH_3 , PF_5) or the solid element (P) are implanted into the silicon wafer by an automated closed vacuum chamber process. Following implant, the wafer must be annealed (by pulse electron, furnace, or laser pulse) to repair damage to the crystal structure caused by ion implantation.

E,H&S Concern: Occupational exposure to toxic phosphorus compounds via inhalation.

Assessment: Although only small amounts of phosphorus dopants are used in this process, and emissions are likely to be minimal, the phosphorus material options available are all toxic at extremely low levels (Owens, et al., 1980). OSHA toxicity limit values (TLVs) vary from 0.1 ppm to 0.3 ppm (ACGIH, 1982). In addition, phosphine (PH_3) is identified as an acute hazardous chemical under RCRA, CAA and CWA, and may have to be treated and disposed of under strict guidelines. Highly sophisticated control and monitoring devices have been developed by the semiconductor industry to prevent and detect even minimal leaks of toxic dopants in the event of a vacuum failure or other accident. However, due to the extreme toxicity of these materials, monitoring response and warning time is not adequate to prevent acute exposure to toxic phosphorus compounds in an emergency (SSD, 1982).

Annealing after ion implantation leaves an oxidized layer on the cells. This layer can only be removed by dilute hydrofluoric acid. Gaseous and liquid dopant diffusion leaves a phosphorus oxide (PO) glass layer on the cells and on the glass diffusion tubes in the gaseous diffusion process. Phosphorus glass is removed from cells by a sequence of front-surface mask application followed by back-surface etch with concentrated HF/HNO_3 acid to remove PO glass and to etch silicon and remove the unwanted back-surface junction. The front mask is then removed with a strong solvent, and finally etched with dilute hydrofluoric acid (10%) to remove the remaining PO glass from the front surface. Prior to the next process phase, the cells must be cleaned with distilled deionized water, and in some cases detergent followed by distilled water, to remove residual acids and solvents.

E,H&S Concern: Health and environmental hazards from improper use and disposal of acids and organic solvents.

Assessment: See discussion in Section II.C.1.a.

2. Gaseous Diffusion

A diffusion furnace is used to dope cell surfaces with a phosphorus dopant (typically phosphorus oxychloride) and form the p-n junction.

E,H&S Concern: Occupational exposure to toxic phosphorus compounds via inhalation .

Assessment: Exposure standards for phosphorus oxychloride (POCl_3) have only recently been adopted (ACGIH, 1982). As interpreted by these standards, POCl_3 is more toxic (TLV = 0.1 ppm) than PH_3 (TLV = 0.3 ppm). Solid phosphorus (P) toxicity falls between POCl_3 and PH_3 . Since POCl_3 standards have been adopted, it may also be added to RCRA's acute hazardous chemical list. Therefore, if control and disposal requirements for these dopants become stricter, costs associated with their use will undoubtedly also increase. Alternatively, less toxic, and hence less costly dopant material alternatives may be investigated. Control requirements and cost impacts associated with newly adopted standards are undetermined.

3. Liquid Dopant

An alcohol or water-based phosphorus-containing dopant is either spun, roller-coated, sprayed, or meniscus-coated onto the cell. Cells are baked dry and then diffused in a convection or infrared furnace at about 900°C . One of the liquid dopants used is phosphoric acid (H_3PO_4), made by adding water to anhydrous phosphorus pentoxide (P_2O_5) just prior to use.

E,H&S Concern: Accidental occupational exposure via skin contact with phosphorus.

Assessment; At present, no OSHA or RCRA standards exist for phosphorus pentoxide. Because phosphoric acid is formed immediately, it can result in severe phosphorus burns on contact with tissue. Phosphoric acid has a toxicity comparable to sulfuric and hydrochloric acids, but it is nearly ten times less toxic (based on TLV standards) than alternative phosphorus dopants. Although extreme caution should be used when handling either phosphorus pentoxide or phosphoric acid, only small amounts of either material are used (Gallagher, 1983). The liquid-dopant diffusion process can be made continuous and automated. Consequently, potential worker exposure to liquid phosphorus-dopants is likely to be minimal.

F. FRONT AND BACK SURFACE METALLIZATION

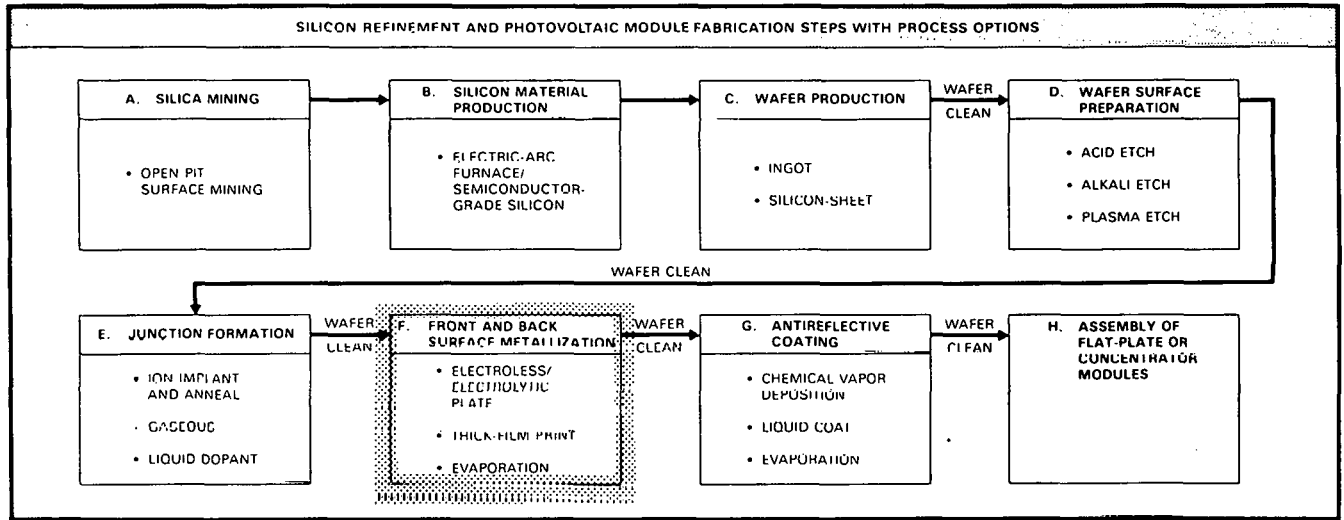

Wafers are metallized to form a back-surface field and back contact and a patterned front-surface current-carrying grid. Metallization is accomplished either by one process or a combination of processes including electroless or electrolytic plating, thick-film printing, and evaporation.

1. Electroless/Electrolytic Plating

A photoresist is applied to a clean wafer. The wafer is then baked to remove excess solvent, covered with a mask defining the metallization pattern, and exposed to a light source to polymerize the resist. The mask is removed and the wafer baked a second time. Acetone is used to remove the unwanted and unfixed resist from the area to be plated. The wafer is then plated with nickel, palladium, copper, or silver. After plating, the polymerized resist is removed with a strong solvent such as toluene or xylene.

E,H&S Concern: Health and environmental hazards from improper disposal of organic solvents.

Assessment: See discussion in Section II.C.1.a.

E,H&S Concern: Health and environmental hazards from improper disposal of plating wastes.

Assessment: Plating wastes contain heavy metals that may be bioaccumulated by humans, animals, and plants, where they can poison vital biological systems. Spent plating wastes are classified as hazardous wastes under RCRA; they are toxic and/or chemically reactive. Spent plating wastes constitute one of the largest liquid effluent waste streams in the semiconductor and PV industries (Coleman, et al., 1979; Moskowitz, et al., 1980). In addition, although the electronic

component industries (Standard Industrial Classification 3600) produce only about 4% of the hazardous wastes in California, these industries are responsible for almost 12% of all toxic metal wastes generated there (California Toxic Waste Assessment Group, 1981). Changes in control requirements, standards, or treatment and disposal costs associated with these wastes could significantly affect these industries.

Because quality control in both the PV and semiconductor industries demands high-purity plating solutions, plating solutions that are no longer suitable for these industries may still be adequate for other industrial plating operations. Spent plating wastes may be reclaimed for sale to industries not requiring high-purity solutions. Wastes that cannot be recycled internally or reclaimed for other uses, however, must be disposed of under RCRA guidelines. Specific wastes may require chemical treatment prior to disposal and some wastes may be disposed of either by chemical treatment or by secure Class I landfill disposal. Chemical treatment costs for toxic metals average \$250 per ton nationally. Class I disposal costs vary from \$60 to \$120 per ton in California depending upon toxicity (Kettleman/BKK, 1983; California Toxic Waste Assessment Group, 1981). Cost impact associated with plating waste disposal is undetermined.

2. Thick-Film Print

Wafers are metallized beginning with the back surface. Aluminum, silver or copper ink is applied to the surface through a mesh screen with a squeegee roller. They are dried and sintered at 550°C, then returned to the printer for the same process to apply a front grid pattern using silver or molybdenum/tin/titanium ink. This process may not be suitable for very thin silicon-sheet wafers (ribbons, for example) because these thin wafers become stressed when the thick film is sintered. Thick-film inks contain valuable metals which will probably be reclaimed for their salvage value.

E,H&S Concern: Occupational exposure to metal inks via inhalation.

Assessment: Analysis of several silver inks used for metallization indicates the presence of significant levels of toxic metals other than silver, including lead, nickel, and antimony. A sample survey of one semiconductor plant having in-place control technology showed that process operators were exposed to silver levels above OSHA standards (U.S. Department of Labor, 1979). According to RCRA, antimony, lead, nickel, and silver are considered hazardous constituents in a waste stream. Based on the sample survey, it was concluded that controls or procedures to prevent occupational exposure to those materials may be either inadequate or improperly executed. With inclusion of metal inks under RCRA guidelines, controls and monitoring of exposure to metal inks are expected to become more stringent. Development of more effective or stricter enforcement of in-place control technologies may be required to meet existing standards. Cost impacts associated with control and treatment of metal inks are undetermined.

3. Evaporation

Prior to metallization, photoresist patterned wafers are placed in a vacuum chamber. Titanium metal is heated in a small boat, and the evaporated metal is then deposited as a fine mist onto the wafers where it solidifies on contact. Titanium, palladium, and copper or silver are deposited in sequence on the wafer. Excess metal condensed on the chamber walls is hand-scraped for recycling.

E,H&S Concern: Potential occupational exposure to metal wastes via inhalation or other contact.

Assessment: Cleaning methods for large-scale evaporation processes have not been determined. E,H&S concerns associated with cleaning an evaporative vacuum chamber will depend upon the cleaning method employed and associated occupational hazards. It is not known whether occupational exposure to metals will be a problem for large-scale operations.

G. ANTIREFLECTIVE COATING

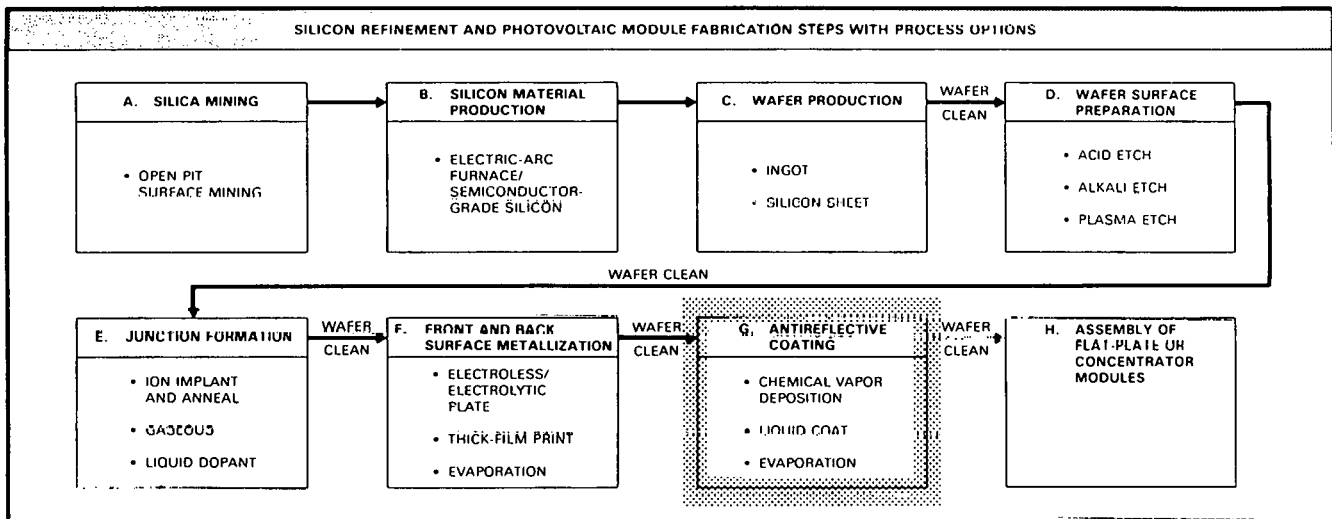

Prior to deposition of the antireflective (AR) coating, wafers are cleaned in dilute (10%) hydrofluoric acid to remove trace solvents and metal. Wafers are given an antireflective coating to decrease loss of sunlight due to reflection. An AR coating is typically applied in one of three ways: chemical vapor deposition, liquid coating, or evaporation.

1. Chemical Vapor Deposition

A diffusion furnace is used for chemical deposition of silicon nitride (Si_3N_4) using dichlorosilane and ammonia as deposition gases in an automated process. Dichlorosilane, ammonia, hydrochloric acid, and hydrogen are effluent gases (Gallagher, 1983).

E,H&S Concern: Occupational exposure to toxic and volatile dichlorosilane and hydrochloric-acid gas via inhalation.

Assessment: See discussion in Section II.B.2.

E,H&S Concern: Occupational exposure to silicon nitride reactant products via inhalation.

Assessment: Diffusion reactor tubes must be periodically cleaned with a hot etchant gas such as hydrochloric acid. Workers may be exposed to silicon nitride or its reactant products. Although silicon nitride is reportedly stable, its toxicity and the toxicity of its reactant products have not been determined. Until toxicity has been determined, precautions should be taken to minimize worker exposure to these materials. Future control requirements and associated control costs are undetermined.

2. Liquid Coating

A semiautomated conveyer belt is loaded with wafers that are sprayed or meniscus-coated with titanium isopropoxide [$\text{Ti}(\text{OC}_2\text{H}_5)_4$] and air-flashed to remove bubbles. The wafers are then infrared dried and fired at 200°C. In another liquid AR coating process, wafers are dipped into a bath of titanium isopropoxide and then oven dried. When solvents are driven from the coating material, titanium dioxide remains.

E,H&S Concern: E,H&S concerns associated with this process are not expected to be significant because fumes produced are minimal, and system ventilation and automatic shutoffs are adequate to prevent accidental leaks into the workplace.

3. Evaporation

A similar evaporative metal deposition process is used for metallization and antireflective coating, except that tantalum metal replaces titanium, palladium, and copper.

E,H&S Concern: Potential occupational exposure to metal wastes via inhalation or other contact.

Assessment: See discussion in Section II.F.3.

H. ASSEMBLY OF FLAT-PLATE OR CONCENTRATOR MODULES

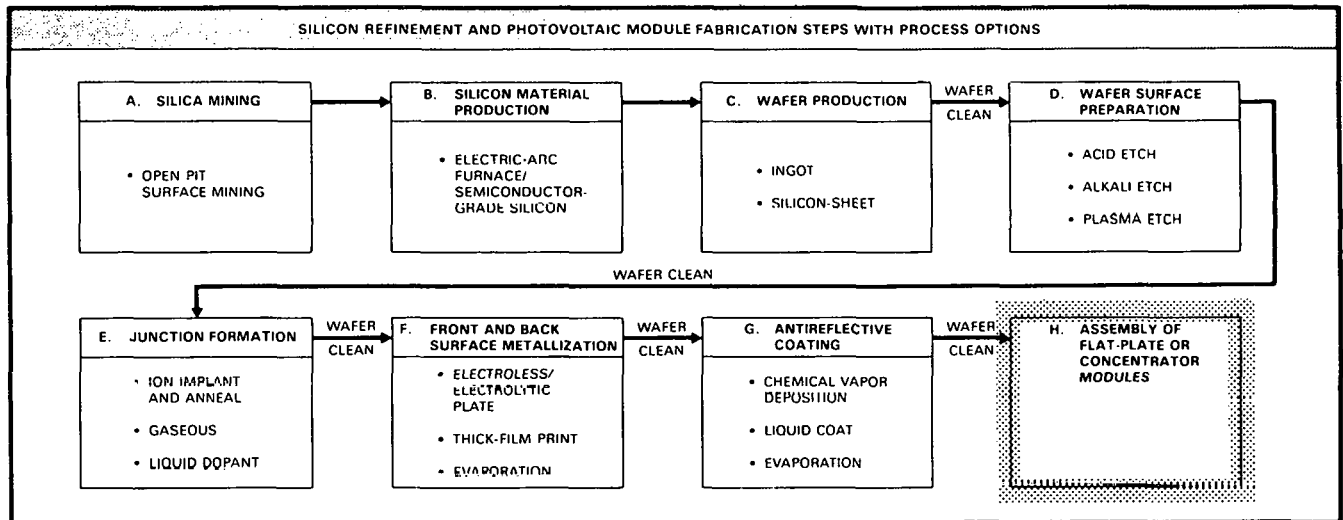

Following a final cleaning, the finished PV cells are ready to be assembled into operative PV modules. Finished PV cells are tested, interconnected, encapsulated, and assembled into a module. The finished modules are then tested to verify performance.

1. Cell Interconnection Substep

In an automated process, cells are aligned and interconnect tabs are soldered into place on the front and back of each cell. An assembly of cells is fed to a solder reflow oven and assembled into a string. Strings are then assembled into a module tray where interconnect tabs are placed on interconnect buses and soldered.

E,H&S Concern: Occupational exposure to metal solders via inhalation and ingestion.

Assessment: Lead/tin solder and zinc chloride flux are used during the interconnection process. Although occupational exposure to metal solders seemed to be well within OSHA standards for this operation, semiconductor industry workers were found to have body burdens of these metals higher than expected based on potential exposure (U.S. Department of Labor, 1979). The Semiconductor Safety Division (SSD), a voluntary organization of E,H&S professionals within the industry-sponsored Semiconductor Industry Association (SIA), has determined that the primary mode of employee exposure to metals was from smoking and consuming coffee and food within the work area (SSD, 1982). Metals were inhaled and/or ingested after cups, food, and cigarettes had been contaminated by the employee's gloved hands. It may be concluded that protective equipment is being used inadequately, industrial hygiene protocol is not observed, or protection equipment is inappropriately engineered to maximize protection in the worker environment.

2. Encapsulation and Module Fabrication Substep

Flat-plate modules are encapsulated against a glass substrate. Ethylene vinyl acetate (EVA) is applied to the glass sheet and the cell assembly is placed on top. An encapsulant cover is placed on the assembly and a sheet of mylar is added. The sandwiched assembly is baked in a double-chambered vacuum laminator or an autoclave to seal it. Concentrator modules are fabricated with plastic Fresnel lenses and are typically not as extensively encapsulated.

E,H&S Concern: Occupational exposure to EVA fumes via inhalation.

Assessment: Modules are autoclaved under a partial vacuum; consequently, potential occupational exposure to fumes should be minimal. The combustion products of EVA have not been determined, but potential emissions include acetic acid, carbon dioxide, carbon monoxide, and monomer constituents. EVA is a copolymer of polyethylene and vinyl chloride, the latter a known human carcinogen and a RCRA toxic waste. Vinyl chloride is also a fire and explosion hazard. It is not known whether vinyl chloride is an EVA combustion product. Therefore, unless it is determined that vinyl chloride is not an EVA combustion product, precautions should be taken to minimize worker exposure to these fumes. If toxicity is demonstrated, strict OSHA and possibly RCRA exposure standards will probably be established. The associated control costs are undetermined. To date, no Federal standards exist regarding occupational exposure to EVA fumes.

3. Cell and Module Testing and Handling Substep

Finished cells and modules are tested to demonstrate function and to rate their performance by exposure to simulated sunlight. Following testing, modules are packaged and transported for system installation at the job site (system deployment is addressed in subsequent sections of this report).

E,H&S Concern: Occupational shock hazard from factory-assembled PV arrays.

Assessment: PV modules produce nearly full voltage even under very low levels of illumination. Thus, the modules are always "on". Shock hazard is a function of module voltage. With most present-day modules, this concern is negligible because of low module voltage (Rabinowitz, 1982). For centralized system applications, however, modules may be factory-assembled into larger sized panels or arrays, with voltages high enough (greater than 30 volts dc) to present a significant electrocution hazard. An uninformed worker who is testing, handling, or transporting finished arrays could be seriously injured or even killed by an accidental shock. Module and array labeling, packaging, and shipping requirements that adequately protect individuals from shock hazards are now being addressed by Underwriters Laboratory Inc. (UL) for JPL.

I. NON-SILICON PHOTOVOLTAIC COLLECTOR MANUFACTURING

Many semiconducting materials exhibit the PV effect and may be used in PV collectors. Currently, and in the near future, commercially available modules will be limited chiefly to crystalline silicon. In the future, however, PV collectors may employ any of several promising "thin-film" materials now being researched, including amorphous silicon, cadmium telluride, copper-indium diselenide, zinc phosphide, gallium arsenide, or cadmium sulfide/copper sulfide (U.S. Department of Energy, 1983). The techniques used to make thin-film cells include vacuum evaporation, glow discharge, reactive sputtering, and chemical vapor deposition.

E,H&S Concern: Advanced "thin-film" processing techniques have not been assessed to determine potential associated E,H&S concerns.

Assessment: With the exception of gallium arsenide and cadmium sulfide/copper sulfide, collectors based on "thin-film" materials presently may be made only with advanced processing techniques. The E,H&S concerns associated with those processes have not yet been assessed. Thin-film processes are inherently attractive because of their low material consumption, low temperature process requirements, and their potential for continuous, large-volume, low-cost PV collector production. Undesirable and costly waste streams such as etchant or plating wastes may be replaced by wastes of undetermined toxicity from new processes. Control technology requirements and costs associated with thin-film processes cannot be determined until these processes and their waste streams have been characterized and the relative hazardousness or toxicity of effluents determined. The presence of highly toxic and/or hard-to-control effluents could indicate prohibitive control technology costs which would affect the viability of technologies based on certain PV collector materials.

SECTION III

RESIDENTIAL PHOTOVOLTAIC SYSTEM DEPLOYMENT

SUMMARY MATRIX

This section discusses E,H&S concerns associated with residential system deployment. Compared with module fabrication processes, issues associated with residential deployment are less well understood because experience with operating systems is limited. The following matrix (Table 2) summarizes the residential system phases, identifies the E,H&S concerns associated with each phase, and summarizes the assessment of those concerns. Residential PV system deployment includes system construction and operation. Off-normal events, particularly those which may result in fire, are also included in this section.

Table 2. Environmental, Health, and Safety Concerns Associated with Roof-Mounted, Residential Photovoltaic System Deployment

Process Step	E,H&S Concern(s)	Assessment (cost impacts are undetermined)
A. System Construction	-Public and occupational shock hazard from modules/arrays	-Public and occupational populations are unfamiliar with PV -Compliance with projected codes and standards will mitigate most but not all present safety concerns
B. System Operation	-Public and occupational shock hazard -Flammability of the PV array -Occupational and public exposure to toxic PV combustion fumes	-Public and occupational populations are unfamiliar with PV -Uniform operation and maintenance guidelines and safety procedures are presently unavailable -Requirements for module fire resistance being developed will mitigate present concerns -Toxicity and safe exposure levels are unknown

Because of the modular nature of PV modules and panels, PV systems can be tailored to any size. Residential systems will typically be in the 2 to 8 kW_p size range and may be either independent of, or connected to, the utility grid. Residential systems may be roof or ground mounted, although roof-mounted systems will probably predominate because existing roof members can be used for the array support structure. Concentrator arrays and tracking flat-plate systems will probably not be used in near-term residential applications because they occupy more space than fixed flat-plate arrays and require more complex support structures in order to track the sun.

Residential systems may be installed as a part of new construction or may be added as retrofit systems to existing homes. There are four basic mounting schemes (see Figure 2) by which a roof-mounted system may be installed: direct, integral, standoff, and rack (Burt Hill Kosar Rittelman Associates, 1979). Direct and integral mounting schemes are especially suitable for new construction because the PV modules replace standard shingles or other roofing material. Standoff and rack mounting schemes may also be used in new construction, but are especially suitable for retrofit construction because the system can be positioned at an optimal angle with respect to the sun.

Residential systems will be installed by local building contractors and/or electricians. System diagnostics, repair, and major maintenance will be performed by trained service personnel. The homeowner may undertake certain limited maintenance activities, such as keeping the array clear of debris and vegetation. Residential PV system deployment includes system construction and operation; system maintenance is part of the operational phase.

A. SYSTEM CONSTRUCTION

Whether new or retrofit, residential PV system construction begins with delivery of components to the job site. Upon delivery, PV components are inspected for shipping damage and the modules tested to verify their electrical and structural integrity. Once inspected and tested, components may be stored until installation. To install the PV system, individual modules or field-wired panels are attached and secured to the roof structure, and array wiring is completed. The power conditioner is installed, and interface wiring, and protective devices, such as overcurrent and lightning surge protection, system grounding, manual disconnect switches, are connected to complete the system. The finished system is inspected by local authorities and is checked out according to a prescribed sequence to verify proper system operation, safety, and electrical performance (Forman and Klein, 1982; Jet Propulsion Laboratory, 1983).

E,H&S Concern: PV modules, individually or as part of a system, may present a shock hazard condition to public and occupational populations.

Assessment: PV modules are electrically active when exposed to any light source; hence, they are always "on". A partially assembled system

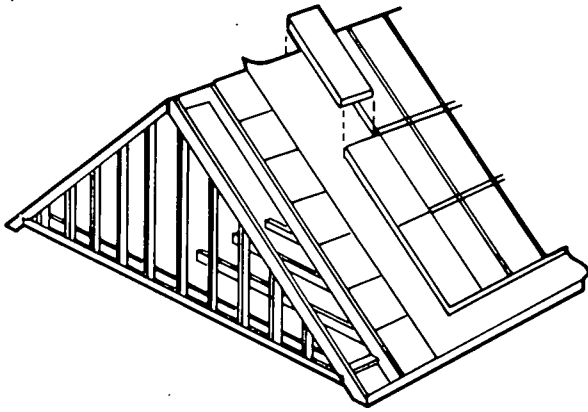

DIRECT

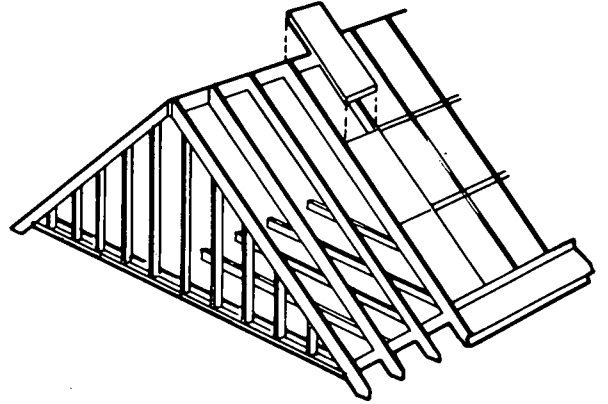

INTEGRAL

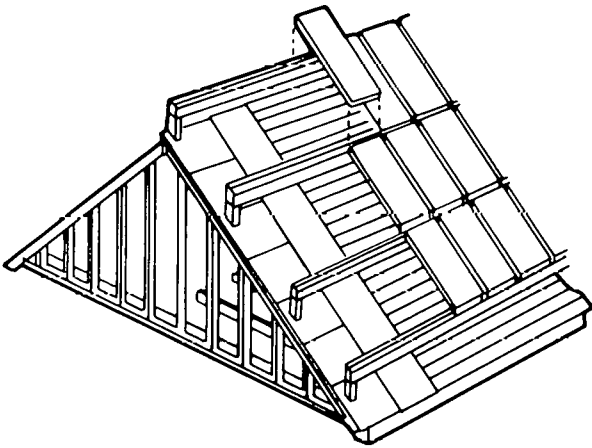

STANDOFF

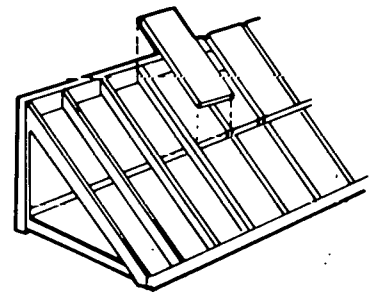

RACK

Figure 2. Four Basic Array Mounting Schemes

or a fully assembled system under low illumination may generate lethal voltages (Rabinowitz, 1982).

Many safety concerns associated with construction of residential systems are addressed by various codes and standards. The most widely adopted set of electrical requirements is the National Electrical Code (NEC). Until recently (1983), PV installation requirements were not addressed by any code or standard. Since then, the NEC has been revised and will address PV systems in Article 690 of the 1984 edition of the Code (NFPA, 1982). To further minimize safety concerns associated with fire, shock and casualty, UL has developed a Standard for Safety for flat-plate PV modules and panels (UL, 1982). The requirements of the NEC and the UL standard are interrelated; the UL standard addresses the factory-built item and the NEC addresses the system installation. The UL standard and the NEC describe levels of safety considered appropriate for product construction and installation that afford practical safeguarding of persons and property arising from the generation and use of PV electricity.

For the near term, most new systems will be custom designs built by an industry with relatively limited experience in PV and constructed from components that are new to the home construction industry. Complying with the NEC provisions and UL requirements will ensure that most PV electrical safety concerns have been addressed.

At present there is no network of trained PV installers or service personnel. Because of PV's unique operating characteristics, inexperienced workers will require informational assistance until practical experience with PV can be gained. Informational assistance, e.g., specific system design and installation manuals from the system designer or generic technical information based on experience derived from National PV Program system experiments, will assist in the development of installation, operation and maintenance guidelines that protect PV hardware, the residence, the occupants, and the workers. Programmatic PV residential design documentation is under preparation and may be expanded to address design-specific safety concerns by the emerging residential PV industry (Sandia National Laboratories, Photovoltaic Residential Design Documentation Task).

B. SYSTEM OPERATION

Residential PV system operation activities include routine operation and maintenance. As stated previously, homeowner maintenance responsibilities should be minimal. Maintenance activities that should be performed only by trained service personnel include array washing, performance checks, system diagnostics in the event of system malfunction, and repair and/or replacement of damaged components including array modules.

Although not a part of normal system operation and maintenance, off-normal events and the subsequent emergency conditions may present increased

hazard both to occupants of the residence and to emergency response personnel. Off-normal events consist of man-made and natural disasters, including fires and earthquakes.

E,H&S Concern: Electric shock hazard conditions from the system during maintenance activity.

Assessment: Because a PV system is electrically active whenever illuminated, service personnel must be expected to work on a live system. Although in some cases subsystem components can be electrically isolated and/or voltages reduced to safe levels, the array subsystem cannot be completely turned off. Service personnel new to PV maintenance and "do-it-yourself" homeowners attempting to troubleshoot and repair their own systems risk electrical shock. Mechanisms by which a shock may occur have been examined but are not well understood (Sugimura, 1983). Limiting access to high-voltage components and provision of labels, warnings, and posted instructions will reduce some of the risk associated with this concern. As with other electrical products, it is unlikely that all conceivable shock hazards associated with the operation and maintenance of PV systems can be prevented if the system is to retain its utility.

E,H&S Concern: Flammability of the PV array.

Assessment: Residential system concerns associated with array/module flammability involve two distinct risk areas: (1) the likelihood or ability of a module to ignite itself from an electrical arc and then lead to flame spreading beyond the arc site, and (2) the likelihood or ease of a module being ignited by an external flame source such as a flying ember or burning brand. These factors affect the flammability of a roof, and are especially important where local restrictions apply.

Residential roof-mounted arrays constitute a sensitive application class because the operating voltage and current levels are sufficient for sustained arcs, and the array is in close proximity to other flammable elements which can serve as a source to ignite the array or fuel the flames. More important, the array is likely to be close to personnel, so that risk to human life is involved.

Most residential building codes have no quantitative requirements for flame resistance of materials, but the modules will generally have to be listed (NEC, 1984), certified as being reasonably safe, by a nationally recognized testing organization such as UL. This listing requires insensitivity to ignition from arcs, but not from external flame sources. Product liability guidelines simply suggest that a PV array should not present an unreasonable or unexpected fire hazard. One interpretation is that a PV roof-mounted array should be no more flammable than a typical wood shingle or shake roof.

Fire-rated applications is a category that involves arrays where fire risks are high and specific fire-resistance levels have been established. Examples include public buildings and residential roofs in specific communities with a high fire-risk concern. The National Fire

Protection Association (NFPA), in conjunction with UL and the American Society for Testing Materials (ASTM), has established three classes: A, B and C; A being the most fire resistant, followed by B and C. The requirements and test procedures defining these ratings are presented in Safety Standards, such as UL Standard No. 790.

Comparison of the fire-resistance requirements of residential PV applications with the measured capabilities of the leading candidate module constructions indicates that the two are generally consistent. Additional activities, however, are being carried out to further clarify the issues. These include: (1) additional testing of materials, such as EVA, to verify their ability to meet the requirements of module listing for typical non-fire-rated applications; (2) definition of technical parameters required to prevent arc-initiated fires; and (3) experimentation with low-cost means of improving fire resistance of candidate module constructions (Sugimura, 1983).

E,H&S Concern: Exposure to toxic PV combustion products via inhalation in the event of a residential fire.

Assessment: In the event of a residential fire involving a PV roof array system, off-gassing of toxic fumes has been identified as a potential health hazard (Neff, 1979; Weinstein and Meeker, 1981). Current manufacturing techniques favor ethylene vinyl acetate (EVA) as an encapsulant material. As discussed previously (Section II.I.1), few data are available on the toxicity of EVA combustion products. Firefighters who are routinely exposed to toxic combustion products employ air-filtering masks, self-contained breathing apparatus, and other safety equipment to protect them from potential exposure to harmful materials. If EVA combustion fumes are determined to be toxic, firefighters may still experience some chronic low-level exposure to these fumes because current residential firefighting equipment does not provide total protection. Residents are exposed to only negligible amounts of toxic combustion fumes because home fires are typically isolated incidents.

Currently, and in the near future, residential PV collector materials will be limited to silicon. PV modules in the future, however, may contain materials such as gallium arsenide, cadmium sulfide/copper sulfide, cadmium telluride, zinc phosphide, or copper-indium diselenide. Many of the advanced collector materials contain acutely hazardous or toxic substances, giving rise to additional health concerns. In the event of fire in residences having PV systems based on advanced materials, firefighters could be chronically and repeatedly exposed to toxic heavy metals. It seems unlikely that the public will be exposed to dangerous levels of these materials during a single residential fire (Moskowitz, et al., 1980). Potential off-gassing, toxicity, and public and occupational exposure to certain PV collector materials and cell material options have not been investigated. The presence of toxic and/or flammable PV combustion products could affect the viability of technologies based on certain PV collector materials.

SECTION IV

CENTRAL-STATION SYSTEM DEPLOYMENT

SUMMARY MATRIX

This section discusses E,H&S concerns associated with central-station system deployment. Although these issues may not prove to be significant, it is significant that many of these concerns are not well understood and have not been completely assessed because of limited experience within this application area.

The matrix shown in Table 3 summarizes central-station system phases, identifies the E,H&S concerns associated with each phase, and summarizes the assessment of those concerns. Central-station system deployment includes system construction and operation. Off-normal events, especially those which may result in fire, are also included in this section.

Central-station PV systems are large, ground mounted, typically utility owned, and grid connected. Centralized systems may range in size from 1 MW_p to 100 MW_p or larger. Depending upon local terrain, insolation, collector efficiency, and system design, centralized systems require approximately 2 to 4 hectares of land per MW_p (Patten, 1980). Because the collector arrays for large systems require substantial land areas, many future scenarios assume that large systems will be built predominately in desert locations because of relatively low land costs and high insolation levels. Realistically, centralized PV systems will be placed in any geographic region where competing conventional energy costs, social acceptance, and land availability make them feasible. Photovoltaic plant sites favorable from the utility perspective may eventually encompass a wide range of ecosystems and geographic regions.

There are three design options for central-station arrays; fixed flat-plate, tracking flat-plate, and concentrator designs (Figure 3). Each option has certain advantages and tradeoffs.

Central-station system deployment includes system construction and operation. System construction requires site preparation prior to system installation, while system operation encompasses routine operation and maintenance. Special operations are required in the event of off-normal events or emergencies.

A. SYSTEM CONSTRUCTION

Central-station system construction begins with site preparation. Site preparation is followed by component delivery, system installation, and system startup and checkout. Site preparation includes, where necessary, removal of vegetation and obstructions to construction, surface grading, and re-surfacing. Building of service and access roads and construction support buildings is also a part of site preparation.

Table 3. Environmental, Health, and Safety Concerns Associated with Ground-Mounted, Central-Station Photovoltaic System Deployment

System Phase	E,H&S Concern(s)	Assessment (cost impacts are undetermined)
A. System Construction	-Environmental disruption of large land areas	-Alteration of standard construction practices may reduce this concern
	-Occupational shock hazards from arrays/system	-Guidelines for large system construction are being developed
		-Occupational populations are unfamiliar with PV
B. System Operation		
1. Routine Operation	-Ecological disruption from presence of PV system	-Impacts and methods of mitigation are unknown
	-Climatological disruption from presence of PV system	-Impacts and methods of mitigation are unknown
2. Routine Maintenance	-Occupational shock hazards from arrays/system	-Operation and maintenance guidelines are being developed
	-Water demand for array cleaning in water-deficient areas	-Standard washing techniques may be too water-consumptive in some areas
	-Environmental disruption from vegetation control	-Insignificant with proper procedures
3. Off-normal events resulting in fire	-Flammability of the PV array	-Probably not significant; detailed studies are in progress
	-Public and occupational exposure to toxic PV combustion products	-Toxicity and safe exposure levels are unknown
	-Fire hazards from power conditioner chemical spills	-Insignificant with proper siting

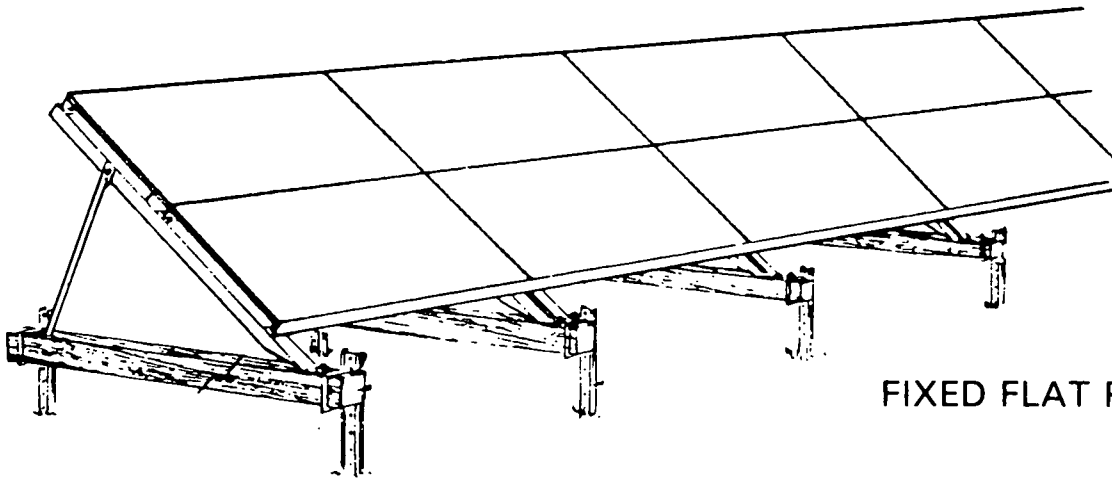

FIXED FLAT PLATE

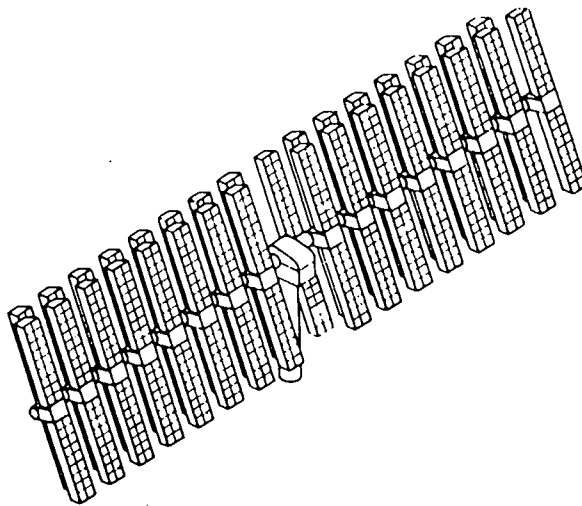

CONCENTRATOR

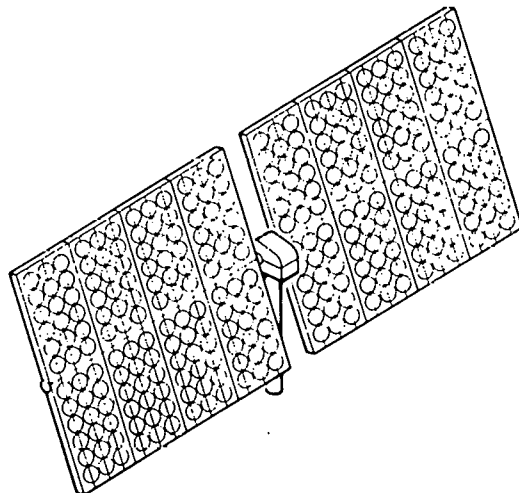

TRACKING FLAT PLATE

Figure 3. Central-Station Array Designs

Following site preparation, the PV system components are delivered to the site and, as necessary, stored prior to installation. As in residential system construction, the system components are checked for damage upon delivery and the PV modules or factory-assembled panels or arrays are tested to verify electrical integrity. The array field and associated support components including the power conditioning and transformer units are then installed. The power plant service buildings are also constructed at this time. The system is inspected by the utility against prescribed specifications at key points during system construction. Following installation the system is put through a prescribed sequence of startup and checkout to verify proper installation and electrical performance and to test safety and control functions.

E,H&S Concern: Site preparation and system construction disrupt large land areas and their associated ecosystems.

Assessment: Centralized PV facilities use large land areas. Ground-mounted, fixed flat-plate PV array fields require a minimum of about 2 hectares per MW_p, given optimal insolation, terrain, and collector efficiencies greater than 10%. Concentrator and tracking flat-plate array fields require approximately 30% more area because array shadowing must be minimized to maximize the benefits of a tracking system (Burt Hill Kosar Rittelman, 1982). When land required for access roads and service buildings is added to array field requirements, these areas increase. Construction activities damage and disrupt the physical terrain and local ecosystems. The severity and extent of disruption due to construction depends largely upon the fragility of the ecosystem and the amount of land required.

Early designs for central-station systems typically included standard site preparation, which involves land clearing, grubbing, grading, and artificial re-surfacing. However, even systems that can use a site in its natural state will alter land and ecosystems by array installation, service building construction, road building, and off-road vehicle traffic. Environmental impacts of large-scale land use in desert locations could be considerable. Wind erosion would increase because the protective desert crust, or pavement, would be broken. The effects of water erosion would also increase. Fragile, thin-layer ecosystems typical of desert environments require decades to recover from construction activities (Turner, 1979, 1980). Less delicate ecosystems usually recover more rapidly. System sites will probably be chosen to avoid dense wildlife populations and areas where fragile land or ecosystems would be significantly impacted by construction activities.

E,H&S Concern: Electrical shock hazards are associated with central-station system installation.

Assessment: In general, workers constructing a utility-sized system are likely to be aware of the hazards associated with PV, especially if appropriate cautions are incorporated into working plans and procedures prepared for system installation. Depending upon the system design and module technology chosen, workers may wire modules into panels and arrays at the job-site, or factory-assembled panels or arrays may be installed directly. Although workers are expected to be familiar with the hazards associated with PV and, accordingly, are expected to follow safe work practices, they must ultimately work with potentially hazardous voltages.

A detailed risk assessment of occupational hazards associated with central-station deployment, which includes operation and maintenance in addition to installation, has not been performed to date. Within the National PV Program, no centralized systems of sufficient size have yet been operated on which to base an analysis. Because of savings due to economies of scale, use of automated machinery, and worker familiarity with PV, centralized systems may present fewer occupational risks per kilowatt-installed than residential systems.

B. SYSTEM OPERATION

Central-station PV system operation activities include routine operation, routine maintenance, and emergency activities associated with off-normal events, especially fire.

1. Routine Operation

Routine operation activities involve plant monitoring and control (i.e., daily startup, shutdown, grid synchronization, and equipment monitoring), security, and communications. Although some hazards are associated with each of these activities, none is inherently unique to PV. Also, many of these plant operation activities are automatic; hence, the risk associated with many tasks is negligible.

E,H&S Concern: Ecological disruption because of the presence of a PV system.

Assessment: Local ecosystems may react, either positively, negatively, or not at all depending upon geographic region, to the presence of an installed array field. Collectors covering approximately 50% of the ground surface block from 50 to 80% of the daily incoming solar radiation, depending on the season. Modification of surface wind flow, surface temperatures, and evapotranspiration rates within the array field are seen because of the presence of an array canopy (Hanks, et al., 1967). Biota in desert locations could exhibit a positive response to these changes within the array field microenvironment because shading conserves deep soil moisture (Smith, 1981). A decrease in available

sunlight for desert plants may not inhibit growth under most circumstances. In humid ecosystems, however, the reduction in available sunlight may limit plant growth although the adverse impact that shading creates in this case is not expected to be significant.

Plans for large solar facilities in the arid southwestern United States must recognize that most of this arid region suffers from blowing dust and sand during one or more yearly seasons. For hydrological and economic reasons, resurfacing large land areas is impractical, yet surfaces beneath the collector canopy must be stabilized. Environmentally and economically, arid regions benefit when vegetation is allowed to remain within the array field. Land surfaces are stabilized by native vegetation which, in turn, benefits from supplemental water within the array field.

E,H&E Concern: Potential climatological disruption because of the presence of a PV system.

Assessment: It has been speculated that very large central-station PV power plants (greater than or equal to about 100 MW_p) may alter local climates by modifying the surrounding solar radiation balance. Array shading can cause changes in ground surface albedo, thermal conductivity, heat capacity, emissivity, and other surface characteristics. Sufficiently large changes in these characteristics could lead to climatological disruption including the formation of localized thunderstorms, and alteration of wind and rainfall patterns (Bhumralkar, et al., 1979, 1980).

2. Routine Maintenance

Maintenance activities on central-station PV facilities involve array cleaning, module and subsystem performance testing, diagnostics in the event of malfunction, repair and/or replacement of failed modules, maintenance of power conditioners and other electrical subsystems, adjustment to and maintenance of tracking mechanisms for concentrator and tracking flat-plate systems, road maintenance, and grounds maintenance.

E,H&S Concern: Electric shock from the system during maintenance operations.

Assessment: Maintenance operations on PV central-station facilities may require the handling of electrically active elements. Maintenance is hazardous since arrays operate at lethal voltages, even under low-level light conditions. Hazards arising from maintenance activities may include shocks from accidental contact with live components, burns from handling overheated arrays, cuts from broken glass and injuries incurred by a fall. Concentrator and tracking flat-plate systems introduce risks instead of, or in addition to, those associated with fixed flat-plate system maintenance because of the additional tracking mechanism.

Because concentrator systems may be defocused for maintenance activities, the risk of receiving a severe shock from the live system is substantially reduced. Photovoltaic systems using resistance-grounded circuits may reduce electrical shock hazard potential to safe levels.

Insufficient experimental data and experience have been gathered on which to base firm operation and maintenance requirements. As stated previously, no large centralized systems have yet been operated within the National PV Program. Safety procedures for maintenance operations were specifically written for the 25-kW_p Mead, Nebraska, prototype facility because of its uniqueness and the previous lack of safety regulations addressing PV systems (Forman and Landsman, 1978). However, the Mead prototype differs substantially in design from concentrator and newer flat-plate systems. Some electrical safety problems associated with system maintenance are addressed by UL standards. Operation and maintenance guidelines and recommended safety practices for central-station PV applications are currently being developed.

E,H&S Concern: Increased water demand for array cleaning purposes in water-deficient regions.

Assessment: Frequency of array cleaning and subsequent water use is determined, in part, by the environmental setting of the array field and the regional precipitation which may contribute to, or in some areas eliminate the need for, array cleaning. Array surfaces are subject to soiling by a variety of contaminants including common dust, sand, plant volatiles, bird excrement, and oily hydrocarbons from airborne pollutants. The extent of soiling by these contaminants will depend upon the location of the array field and the condition of the surrounding ground surface. For example, an unstabilized ground surface will contribute to array soiling by sand and dust, and an array proximate to a large metropolitan area will be subject to a higher degree of pollutant soiling. Soil, including oily hydrocarbons, may be removed by a mild detergent wash (many non-foaming, non-toxic, biodegradable solvents are available) followed by an ordinary tap water rinse (Hoffman and Maag, 1980). Cleaning water may be reclaimed and reused to some extent; however, a certain percentage (up to 40%) is lost by evaporation. The impact that increased water demand will have in water-deficient regions is site and design-specific. Availability and competing demand for water must be taken into consideration when siting large PV facilities in arid regions. The impact of PV-related water use on facility siting has not been assessed.

E,H&S Concern: Environmental disruption because of vegetation control measures.

Assessment: If natural vegetation is left intact during site preparation and array installation operations, then some degree of vegetation control may be necessary to prevent interference with system operation. Tracking mechanisms may be especially vulnerable to vegetative fouling, depending upon structure height and type of indigenous vegetation.

Vegetation control is not unique to PV. Fire breaks, transmission corridors, and unpaved access roads typically must be kept clear. Manual, mechanical, or chemical (i.e., herbicides) methods of control are available. Array shading may limit plant growth in some regions (e.g., temperate zones) while, conversely, growth rates may be so slow that vegetative fouling is not a problem in other regions (e.g., arid zones). Environmental concerns associated with vegetation control within the PV array field will probably be insignificant.

3. Off-Normal Events Resulting in Fire

Off-normal events, consisting of man-made or natural disasters, include major fires and earthquakes. Although not a part of normal system operation and maintenance, the possible consequences of these events may require subsequent emergency activities such as firefighting and emergency treatment of personnel.

E,H&S Concern: Flammability of the PV array.

Assessment: Central-station concerns associated with array/module flammability, as in the residential case, involve both module self-ignition from an electrical arc and ignition from an external source.

Central-station applications will generally involve system voltages above 200 volts, well above the minimum level for sustained arcing. Electrical arcs because of ground faults are expected periodically, so the modules must prevent the damage from spreading beyond the arc site. In addition, the array must be modestly resistant to ignition from external sources such as flying embers.

Comparison of the fire-resistance requirements of central-station PV applications with the measured capabilities of present configurations indicates that the two are generally consistent. In addition to the previously described activities to clarify remaining array flammability issues (see Section III.3), efforts are continuing to further define the flammability requirements of central-station applications (Sugimura, 1983).

E,H&S Concern: Exposure to toxic PV combustion products by occupational and public populations via inhalation.

Assessment: Significant health and environmental hazards may be associated with the release of large amounts of PV collector combustion products in the event of a major facility fire. Flat-plate encapsulant and concentrator lens materials are flammable, but the toxicity of their combustion products has not been determined. In addition, certain advanced collector materials contain identified acutely hazardous substances which can contaminate collector combustion fumes even if encapsulants and concentrator lenses are found non-toxic. Potential

toxicity, downwind magnitude, and public and occupational exposure to various PV collector combustion products which may be released during a major facility fire are unassessed. The presence of toxic and/or flammable PV combustion products may affect the viability of technologies based on certain PV collector materials for this application or the suitability of central PV systems in certain locations.

E,H&S Concern: Potential fire safety hazards associated with accidental power-conditioner fluid spills.

Assessment: In general, high-voltage power conditioners used in central-station PV systems will contain oil-based dielectric fluids. Dielectric fluids now used have low toxicity, high rates of biodegradability, and are somewhat flammable (Westin, 1979). A dielectric fluid spill from utility-sized power conditioners could complicate or even cause a fire hazard in the event of a major accident. Although the use of dielectric-filled power conditioners and transformers is not unique to PV, there is moderate reason for concern about power-conditioner placement and fluid spill prevention because of the flammability of certain PV collector materials (see preceding E,H&S concern).

THIS PAGE
WAS INTENTIONALLY
LEFT BLANK

SECTION V

SYSTEM DECOMMISSIONING

SUMMARY MATRIX

This section addresses the E,H&S concerns associated with residential and central-station system decommissioning. For both residential and centralized systems, decommissioning involves removal of the PV system from service. Although PV systems are built to have a 20- to 30-year operating lifetime, systems that have passed their technical or economic life must eventually be removed. Regardless of system size, PV system decommissioning will probably be performed by knowledgeable professionals. System decommissioning includes electrical and structural dismantlement of the system and treatment or disposal of subsequent waste materials. The following matrix (Table 4) summarizes the phases of system decommissioning, identifies the E,H&S concerns associated with each phase, and summarizes the assessment of those concerns.

Table 4. Environmental, Health, and Safety Concerns Associated with Residential and Central-Station Photovoltaic System Decommissioning

System Phase	E,H&S Concern(s)	Assessment (cost impacts are undetermined)
A. System Dismantlement	-Occupational shock hazards from arrays	-System dismantlement guidelines not yet available
	-Ecological disruption due to central-station system removal	-Impacts and methods of mitigation are unknown
B. Waste Management	-Improper disposal of toxic non-silicon PV materials	-Treatment methods are undetermined

A. SYSTEM DISMANTLEMENT

System dismantlement precedes all structural demolition. Dismantling should follow a sequence to electrically isolate subsystems and reduce system voltages to safe working levels according to accepted procedures.

E,H&S Concern: Electrical shock hazards to workers during system decommissioning.

Assessment: System dismantling is not simply the reverse of system installation. Decommissioning involves dismantling an operational PV system with potentially faulty components. For this reason, decommissioning procedures follow a sequence which systematically reduces system voltages to the lowest possible operating voltage. A low-voltage panel or a single module may represent the lowest possible operating voltage in a residential system. However, for centralized systems that may be built from factory-assembled arrays, the lowest possible operating voltage may be a single, high-voltage array. Although systems will be dismantled in a prescribed sequence by knowledgeable professionals, the possibility of accidental shock cannot be avoided. Occupational shock hazards and the means by which they may be mitigated during decommissioning of high-voltage central-station systems have not been determined.

E,H&S Concern: Ecological disruption because of PV central-station decommissioning.

Assessment: As discussed previously, central-station PV systems may significantly disrupt land and ecosystems during their construction and operation. The extent of initial ecological disruption will determine the nature and severity of effects caused by decommissioning. Wholesale clearance and soil compaction of a central-station site leave the land resistant to future re-establishment of natural vegetation even with artificial revegetation. However, central-station sites in which the natural vegetation has been allowed to remain within the array field and for which site preparation has been kept to a minimum have a good chance for complete recovery. Given time, these sites will eventually return to their original state. Decommissioning quickly reverses micro-environmental changes produced by array shading.

B. WASTE MANAGEMENT

Spent modules, power-conditioning equipment, and other system components are recycled or discarded depending upon their value. Decommissioned PV system equipment may be reused if it is functional, recycled for its recoverable materials, or discarded. Modules destined to be reused will be packaged and handled as new modules, whereas modules destined for recycling or disposal will be electrically deactivated or disabled.

E,H&S Concern: Certain non-silicon PV materials are toxic and can cause health hazards if inappropriately or incorrectly discarded.

Assessment: Disposal of decommissioned material should not pose a problem for the silicon cell technologies. Because silicon, glass, aluminum, and steel are common, non-toxic, and environmentally inert substances, ordinary landfill disposal could suffice. Landfill disposal is relatively inexpensive. For example, 1 ton of flat-plate silicon-based modules (about seven 8 x 20 ft² arrays) can be disposed of by landfill for a disposal fee of about \$4 in Southern California (Los Angeles Sanitation District, 1983). For economic and legal reasons, disposal of

spent PV materials may not be desirable. RCRA requires reclamation where possible, and recycling of spent materials. Competing demand for high-purity silicon by the semiconductor industry may also make recycling of spent PV cells economically desirable in the future.

If non-silicon PV materials such as gallium arsenide, cadmium sulfide/copper sulfide, copper indium diselenide, cadmium telluride, or zinc phosphide are used in PV systems, disposal may be costly. Several of these materials contain acutely hazardous metals which, if incorrectly disposed of in a landfill, could be transported into, and magnified by, biological systems creating health hazards. Certain non-silicon materials may be classified as hazardous and/or restricted and require special treatment (e.g., encapsulation or incineration) prior to disposal. Disposal of hazardous wastes is costly. A cubic yard of cadmium-containing modules (for example, about four 8- x 20-ft flat-plate arrays which weigh just over one-half ton) costs about \$60 in disposal fees alone in California, even though the amount of cadmium contained in the modules is small. Wastes containing arsenic are twice as expensive to dispose of because they are also classified as restricted. Disposal fees do not include the cost of special waste treatment (BKK, 1983; Kettleman, 1983). Recycling or reclamation of toxic PV materials may be a feasible alternative to costly hazardous waste treatment and disposal.

THIS PAGE
WAS INTENTIONALLY
LEFT BLANK

SECTION VI

POSTSCRIPT

The major E,H&S concerns presently associated with crystalline silicon PV system manufacture and deployment options have been discussed in this report. Early assessments of the developing PV technologies identified a variety of potential E,H&S concerns which have not been discussed in this report because they have been either resolved or determined to be insignificant as a result of programmatic research or advances in the technology. This report has been organized sequentially according to PV life-cycle phase to aid decision makers from industry or government in determining what impact these concerns might have on their area of interest. Although the E,H&S concerns identified in this report could be significant with respect to cost impacts within PV, they are controllable and can be mitigated in several ways including process optimization, use of alternative materials and manufacturing methods, and changes in system design. The significance of many E,H&S concerns associated with module fabrication will be a function of material requirements per watt peak of modules produced based on cell and module type and on module efficiency. Higher module efficiency means lower materials consumption for the overall system per watt peak and, consequently, lower waste volumes per watt peak. However, effluent volume alone does not determine the overall relative significance of E,H&S concerns associated with a specific process, and meaningful comparisons can only be obtained through a detailed assessment. Although a brief mention of some E,H&S concerns associated with thin-film technologies is included in each section of this report, an in-depth assessment of the E,H&S concerns associated with those technology options will be addressed in a later report.

THIS PAGE
WAS INTENTIONALLY
LEFT BLANK

SECTION VII

GLOSSARY

A. DEFINITIONS

Albedo - Reflectivity; the fraction of incident radiation at a given wavelength (or wavelengths) reflected by a surface or body.

Alternating Current (ac) - An electric current that reverses its direction at regularly recurring intervals.

Arc - A sustained luminous discharge of electricity across a gap in a circuit or between electrodes.

Array - A mechanically-integrated assembly of modules and panels together with support structure and foundation, tracking, thermal control, and other components, as required to form a dc solar power-producing unit.

Cell - The basic PV device that generates electricity when exposed to sunlight.

Direct Current (dc) - An electric current flowing in one direction only and having a substantially constant value.

Encapsulant - The insulating material enclosing the solar cells and cell interconnects.

Interconnect - A conductor within a module which provides a mechanism for conducting electricity between cells.

Metallization - Electrically conductive metal coating on the surface of a solar cell.

Module - The smallest, complete, environmentally protected, essentially planar assembly of solar cells, designed to generate dc power under unconcentrated terrestrial sunlight.

Panel - A collection of modules fastened together, pre-assembled and wired, designed to provide a field-installable unit.

Photovoltaic - The generation of an electromotive force at the boundary between dissimilarly charged substances when exposed to light.

Photovoltaic (PV) System - The total set of components that combine to convert solar energy into electrical energy suitable for connection to an applicable load. The major subsystems and their interfaces are the array, power conditioning, monitor and control, storage (where necessary), cabling, and power distribution units.

Series Paralleling - A term used to describe the module solar cell circuit configuration or the interconnection of modules to form an array.

Toxic Chemical - A material that when ingested, inhaled, or absorbed into the body in relatively small amounts, may cause physical damage or disturb biological function by its chemical action.

RCRA Hazardous Waste Characteristics:

Ignitable - Presents a fire or explosion hazard; temperature of vaporization (flash point) lower than 60°C.

Reactive - Can cause vigorous chemical reactions when exposed to air, water, or thermal or mechanical shocks.

Corrosive - Can destroy other materials through a chemical reaction; wastes are usually in liquid form and the process is slow. Corrosive wastes have a pH less than or equal to 3 or greater than or equal to 12.

Extraction Procedure (EP) Toxicity - Wastes found toxic following an extraction test designated to identify wastes likely to leach hazardous concentrations of toxic constituents into groundwater under conditions of improper management.

Acute Hazardous Waste - So designated by EPA biological and chemical testing and subsequently listed in Subpart D of RCRA. These wastes include arsenic, cadmium, cyanide, zinc phosphide, phosphorus, and other hazardous metal compounds.

Toxic Wastes - So designated by EPA biological and chemical testing and subsequently listed in Subpart D of RCRA. These wastes include solvents and other toxic organic wastes.

B. ABBREVIATIONS AND ACRONYMS

ACGIH	American Conference of Governmental Industrial Hygienists
AR	Antireflective
CAA	Clean Air Act
CWA	Clean Water Act
DOE	U.S. Department of Energy
E, H&S	Environmental, Health, and Safety
EPA	U.S. Environmental Protection Agency
HF	Hydrofluoric
HMTA	Hazardous Materials Transport Act
JPL	Jet Propulsion Laboratory
MG-Si	Metallurgical-grade Silicon
NAAQS	National Ambient Air Quality Standards
NASA	National Aeronautics and Space Administration
NEC	National Electric Code
NEPA	National Environmental Policy Act

NFPA	National Fire Protection Association
NIOSH	National Institute of Occupational Safety and Health
OSHA	Occupational Safety and Health Act
PO	Phosphorus Oxide
PV	Photovoltaic(s)
RCRA	Resource Conservation and Recovery Act
RF	Radio Frequency
SDWA	Safe Drinking Water Act
SEMI	Semiconductor Equipment and Materials Institute
SG-Si	Semiconductor-grade Silicon
Si	Silicon
SIA	Semiconductor Industry Association
SSD	Semiconductor Safety Division
TCS	Trichorosilane
TD&A	Technology Development and Applications
TLV	Toxicity Limit Value
TWA	Time Weighted Average
UL	Underwriters Laboratory, Inc.

THIS PAGE
WAS INTENTIONALLY
LEFT BLANK

SECTION VIII

BIBLIOGRAPHY

- American Conference of Governmental Industrial Hygienists (ACGIH), Threshold Limit Values for Chemical Substances and Physical Agents in the Work Environment with Intended Changes for 1982. ISBN: 0-936712-39-2.
- Arthur D. Little Co., "Draft Economic Analysis of Subtitle C, RCRA of 1976," Report to EPA, 1979.
- Bhumralkar, C. M., J. Williams, A. Slemmons, "The Impact of a Conceptual Solar Thermal Electric Conversion Plant on Regional Meteorological Conditions: A Numerical Study," Solar Energy 23:393-403, 1979.
- Bhumralkar, C. M., A. J. Slemmons, K. C. Nitz, "Numerical Study of Local/Regional Atmospheric Changes Caused by a Central Receiver Power Plant," DOE/CS/20537-1, 1980.
- BKK Landfill, Los Angeles, California, Hazardous Waste Disposal Price List, July 1983.
- Bureau of Mines, U.S. Department of the Interior, Mineral Commodity Profile: Silicon, February 1979.
- Bureau of Mines, U.S. Department of the Interior, Mineral Commodity Summaries, 1981.
- Burt Hill Kosar Rittelman Associates, Residential Photovoltaic Module and Array Requirements Study, DOE/JPL-955149-79/1, June 1979.
- Burt Hill Kosar Rittelman Associates, "Automated Methods for the Installation of Large Photovoltaic Arrays," based on data presented at the Photovoltaic Systems and Applications Project Integration Meeting, February 1982.
- California Department of Industrial Relations, Semiconductor Industry Study, Division of Occupational Safety and Health, Task Force on the Electronics Industry, 1981.
- California Toxic Waste Assessment Group, Governor's Office of Appropriate Technology, Alternatives to the Land Disposal of Hazardous Wastes, 1981.
- Cartwright, J., Motorola Inc., personal communication, April 1982.
- Casmalia Disposal Site, Santa Barbara, California, "Hazardous Waste Disposal Price List," July 1983.
- Chamberlain, R. G., R. W. Aster, P. J. Firnett, SAMICS Cost Account Catalog Low-Cost Solar Array Project, JPL 5101-154, Jet Propulsion Laboratory, Pasadena, California, April 1980.

- Coleman, M., L. Grenon, N. Hild, Solar Photovoltaic Industry Environmental Control Evaluation Study, Motorola, Inc., May 1981.
- Forman, S. E., D. N. Klein, Safety Inspection Guidelines for Photovoltaic Residences, a subcontract report SERI/TR-11061-1, November 1982.
- Forman, S. E., E. E. Landsman, "Safety Procedures for the 25 kW Solar Photovoltaic Array at Mead, Nebraska," U.S. Department of Energy, MIT/C00/4094-7, April 1978.
- Gallagher, B. D., Flat-Plate Solar Array Project, Jet Propulsion Laboratory, personal communication, June 1983.
- Gandel, M. G., D. R. Sears, Assessment of Large-Scale Photovoltaic Materials Production, EPA-600/7-77-087, August 1977.
- Hanks, R. J., H. R. Gardner, M. L. Fairborne, "Evaporation of Water from Soils as Influenced by Drying with Wind and Evaporation," Soil Science, So. Am Proc. 31, 1967.
- Hoffman, A. R., C. R. Maag, Photovoltaic Module Soiling Studies, May 1978-October 1980, U.S. Department of Energy, JPL 5101-151, November 1980.
- Jet Propulsion Laboratory, Residential Photovoltaic Systems: Installation, Operation and Maintenance, Topical Report to be published in 1984.
- Kettleman Hills Liquid Waste Disposal, Coalinga, California, "Hazardous Waste Disposal Price List", July 1983.
- Los Angeles Sanitation District, "Landfill Disposal Rates for Municipal Solid Wastes," July 1983.
- Moskowitz, P. D., J. I. Barancik, E. A. Coveney, L. D. Hamilton, P. E. Perry, E. Rabinowits, M. D. Rowe, J. Wilcnitz, Health and Environmental Effects Document for Photovoltaic Energy Systems - 1982, BNL-51599, September 1982.
- Moskowitz, P. D., L. D. Hamilton, S. C. Morris, K. M. Novak, M. D. Rowe, Photovoltaic Energy Technologies: Health and Environmental Effects Document, BNL 51284, September 1980.
- National Council on Radiation Protection and Measurement (NCRP), Basic Radiation Protection Criteria, NCRP Report No. 39, January 1971.
- National Fire Protection Association, Inc. (NFPA), National Electrical Code (NEC), Quincy, Massachusetts, 1982.
- Neff, T. L., Social Cost Factors and the Development of Photovoltaic Energy Systems, MIT/EL 79-026, October 1979.
- Owens, T., L. Ungers, T. Briggs, P. Moskowitz, Estimates of Occupational Safety and Health Impacts Resulting from Large-Scale Production of Major Photovoltaic Technologies, BNL 51324, August 1980.

- Patten, D. T. (ed.), "Ecological Disruption Associated with Photovoltaic Energy Generation: Potential Alteration of Habitats and Ecosystem Processes," Proceedings of BNL Workshop on Environmental Effects of PV Energy Technology, Development and Use, June 1980.
- Patten, D. T., Solar Energy Conversion: An Analysis of Impacts on Desert Ecosystems, DOE/COO-4339-3, May 1978.
- Patty, F. A., Patty's Industrial Hygiene and Toxicology. Vol. 3. Theory and Rationale of Industrial Hygiene Practice, Wiley-InterScience Publications, John Wiley and Sons, New York, New York, 1979.
- Rabinowitz, S., Electric Shocks: Health Hazards Associated with a Residential Photovoltaic Energy System, BNL 51659, August 1982.
- Semiconductor Equipment and Materials Institute, Inc. (SEMI), "Standards in Review," Vol. 3, No. 3, September 1983.
- Semiconductor Safety Division (SSD), Proceedings 1982 Annual Meeting, Phoenix Arizona, April 1982.
- Smith, S. D., Microenvironmental Responses of a Sonoran Desert Ecosystem to a Simulated Solar Collector Facility, Ph.D. Dissertation, Arizona State University, December 1981.
- Sugimura, R. S., Flat-Plate Solar Array Project, Jet Propulsion Laboratory, personal communication, September 1983.
- Turner, F. B., ed. Ecological Baseline Studies at the Site of the Barstow 10-MWe Pilot Solar Thermal Power System, Annual Report to the U.S. Department of Energy, UCLA 12-1223, 1979.
- U.S. Department of Energy, National Photovoltaics Program, 1983.
- U.S. Department of Health and Human Services, U.S. Department of Labor, NIOSH/OSHA Pocket Guide to Chemical Hazards, DHEW (NIOSH) #78-210, September 1978.
- U.S. Department of Health, Education, and Welfare, National Institute for Occupational Safety and Health and U.S. Department of Labor, Occupational Safety and Health Administration, "Radio Frequency Sealers and Heaters: Potential Health Hazards and Their Prevention," Current Intelligence Bulletin 33, December 1979.
- U.S. Department of Labor, An Interim Report to the Congress on Occupational Diseases, December 1979.
- U.S. Environmental Protection Agency, Draft Economic Impact Analysis; RCRA, 1979.
- Underwriters Laboratory, Inc. (UL), Development of Photovoltaic Array and Module Safety Requirements, Final Report, JPL 955392-1, 9950-730, June 1982.

Vittrums, V.C., et al., "Pulmonary Fibrosis from Amorphous Silica Dust; a Product of Silica Vapor." Arch. Environ. Health Vol. 32, 1977.

Weinstein, A. S., D. G. Meeker, Report of an Exploratory Study: Safety and Liability Considerations for Photovoltaic Modules/Panels, DOE/JPL 955846-81/1, January 1981.

Westin, R. A., Assessment of the Use of Selected Replacement Fluids for PCBs in Electrical Equipment, U.S. Environmental Protection Agency, PB-296377, March 1979.

