

Westinghouse
Electric Corporation

Water Reactor
Divisions

Tampa Division

Box 19218
Tampa Florida 33616
813-837-7235

MASTER

December 19, 1980

Mr. John Wagoner
Director Procurement Contract Division
U.S. Department of Energy
Oak Ridge Operations Office
P. O. Box E
Oak Ridge, TN 37830

Dear Mr. Wagoner:

SUBJECT: Contract DE-AC05-78OR13511 (formerly EF-78-C-01-2771)

REFERENCE: Eighth Quarterly Report

Attached is the fourth quarterly report FY 80 for reference contract.

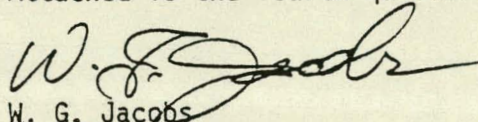

W. G. Jacobs
Contracts Administrator

RLN:pts
Attachments

xc: R. A. Bradley	- PM-ORNL
A. Brunsbold	- LCDM, ANL
J. D. Burleson	- CO, DOE/ORO
S. J. Dapkunas	- DOE-OART (Washington)
J. A. Ford	- DOE/RRT (Germantown)
C. E. Hartblower	- DOT
E. E. Hoffman	- TPO-DOE/ORO
C. J. Long	- TM-ORNL
R. M. Poteat	- DOE/ORO (Oak Ridge)
E. A. Wright	- RPCB-CRBR (Oak Ridge)
Technical Info. Center	- DOE U.S. Dept. of Energy
W. M. Byerley	- WTP
R. Ferrer	- "
E. P. Loch	- "
R. L. Nelson	- "
U. A. Schneider	- "
D. C. Ables	- R&D Center
G. G. Lessmann	- "
L. Mano	- "
D. Moon	- "
I. Stol	- "
E. Landerman	- Penn Center

DISCLAIMER

This report was prepared as an account of work sponsored by an agency of the United States Government. Neither the United States Government nor any agency Thereof, nor any of their employees, makes any warranty, express or implied, or assumes any legal liability or responsibility for the accuracy, completeness, or usefulness of any information, apparatus, product, or process disclosed, or represents that its use would not infringe privately owned rights. Reference herein to any specific commercial product, process, or service by trade name, trademark, manufacturer, or otherwise does not necessarily constitute or imply its endorsement, recommendation, or favoring by the United States Government or any agency thereof. The views and opinions of authors expressed herein do not necessarily state or reflect those of the United States Government or any agency thereof.

DISCLAIMER

Portions of this document may be illegible in electronic image products. Images are produced from the best available original document.

MAJOR CONTRACTOR'S RECOMMENDATION FOR
DISPOSITION OF SCIENTIFIC AND TECHNICAL DOCUMENT

*See Instructions on Reverse

1. EROA Report No. DE-AC05-78OR13511	3. Title DEVELOPMENT OF AUTOMATED WELDING PROCESS FOR FIELD FABRICATION OF THICK WALLED PRESSURE VESSELS - FOURTH QUARTER, FY80
2. Subject Category No.	
4. Type of Document ("X" one)	
<input checked="" type="checkbox"/> a. Scientific and Technical Report	
<input type="checkbox"/> b. Conference paper:	
Title of conference _____	
Date of conference _____	
Exact location of conference _____	
<input type="checkbox"/> c. Other (Specify, Thesis, Translation, etc.) _____	
5. Copies Transmitted ("X" one or more)	
<input type="checkbox"/> a. Copies being transmitted for standard distribution by ERDA-TIC.	
<input type="checkbox"/> b. Copies being transmitted for special distribution per attached complete address list.	
<input checked="" type="checkbox"/> c. Two completely legible, reproducible copies being transmitted to ERDA-TIC.	
6. Recommended Distribution ("X" one)	
<input checked="" type="checkbox"/> a. Normal handling (after Patent clearance): no restraints on distribution except as may be required by the security classification.	
<input type="checkbox"/> b. Make available only to U.S. Government agencies and their contractors.	
<input type="checkbox"/> c. Make available only within ERDA and to ERDA contractors.	
<input type="checkbox"/> d. Make available only within ERDA.	
<input type="checkbox"/> e. Make available only to those listed in item 12 below.	
<input type="checkbox"/> f. Other (Specify) _____	
7. Recommended Announcement ("X" one)	
<input checked="" type="checkbox"/> a. Normal procedure may be followed.	
<input type="checkbox"/> b. Recommend following announcement limitations: _____	
8. Reason for Restrictions Recommended in 6 or 7 above.	
<input type="checkbox"/> a. Preliminary information.	
<input type="checkbox"/> b. Prepared primarily for internal use.	
<input type="checkbox"/> c. Other (Explain) _____	
9. Patent Clearance ("X" one)	
<input checked="" type="checkbox"/> a. EROA patent clearance has been granted by responsible EROA patent group.	
<input type="checkbox"/> b. Document has been sent to responsible EROA patent group for clearance.	
10. National Security Information (For classified document only: "X" one)	
<input type="checkbox"/> a. Document does contain national security information other than restricted data.	
<input type="checkbox"/> b. Document does not contain national security information other than restricted data.	
11. Copy Reproduction and Distribution	
a. Total number of copies reproduced _____	
b. Number of copies distributed outside originating organization _____	
12. Additional Information or Remarks (Continue on separate sheet, if necessary)	
13. Submitted by (Name and Position) (Please print or type)*	
U. A. Schneider, Program Coordinator & Project Manager	
14. Organization	
Westinghouse Electric Corporation, Tampa, FL	
15. Signature	16. Date
W.G. Jacobs, Contract Administrator	9/28/80

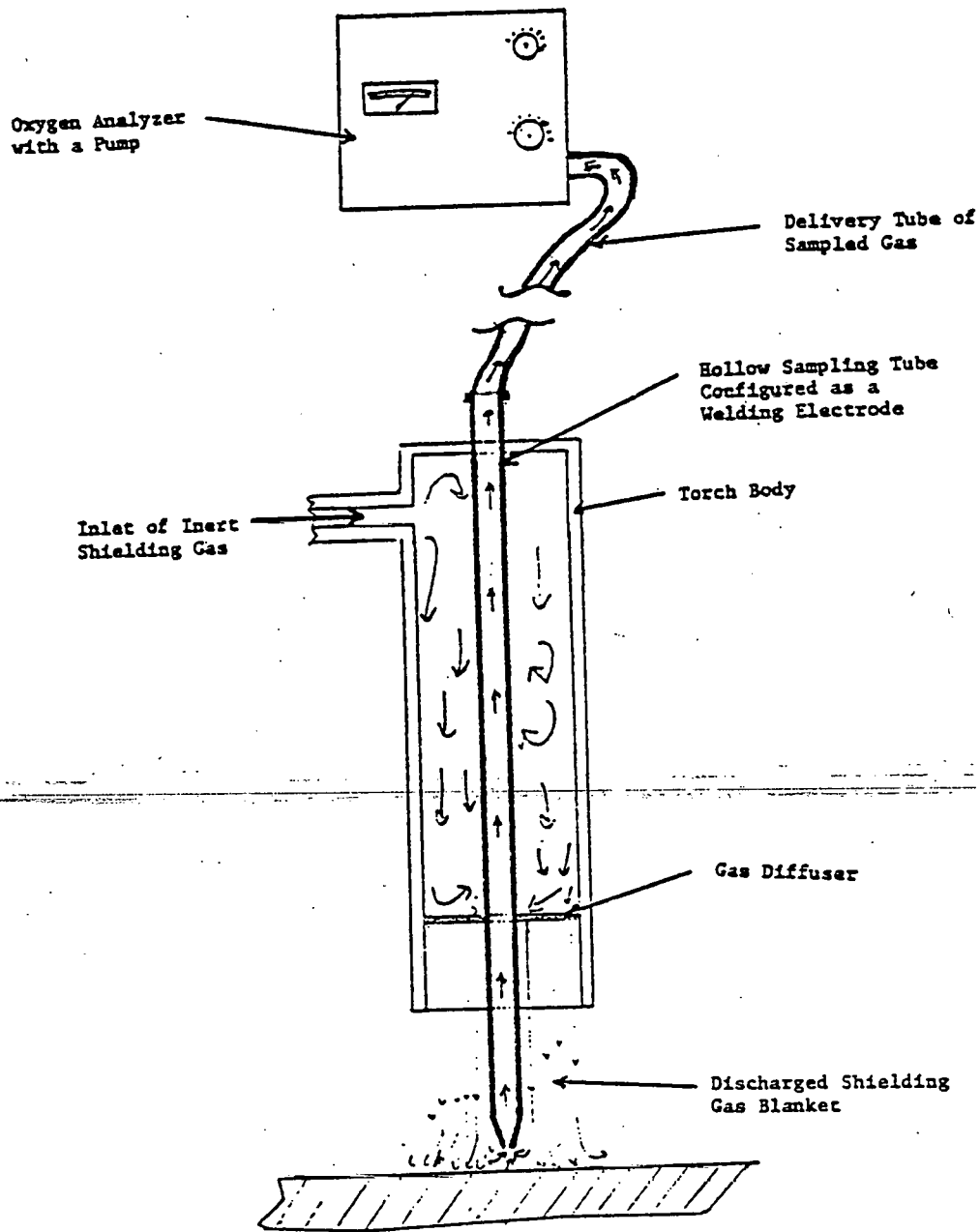

Figure 2.4-1 - System used for characterization of shielding quality delivered by the torch.

To summarize, the narrow-groove torch design used is suitable for welding the 2-1/4% Cr-1% Mo alloy (SA 387). For maximized shielding quality, maintain shortest electrode stick-outs and gas flow rates that are practically and economically feasible.

The shielding effectiveness study was conducted on Tip No. 7 because it most commonly employed in welding the narrow groove.

The oxygen level of the He/Ar gas mixture, measured about the gas inlet to the torch, was 6 ppmv. Therefore, the impurity levels of the element introduced by the environment about the sampled welding area are the reported levels minus 6 ppmv.

From Figures 2.4-4 through 2.4-13, it is learned that in both welding positions:

- (1) The shielding quality deteriorates as the apparent stick-out (Figure 2.4-3) increases, Undoubtedly, this variable has overriding importance.
- (2) Oscillation has an insignificant effect on the impurity level introduced into the shielding gas.
- (3) Speed of torch travel does not have a pronounced effect upon the gas integrity. No definite trend can be associated with this variable.
- (4) Increased flow rates improve the shielding quality of any helium/argon mixture within the joint.
- (5) The enrichment of helium beyond 50% in the mixture decreases shielding quality at most flow rates studied.
- (6) With the current torch and joint designs, the oxygen introduced into the narrow groove is within the 100 to 750 ppmv range. A substantial amount of destructive and nondestructive testing carried out on 2-1/4% Cr-1% Mo weld deposits, made with this torch, has shown acceptable results. Therefore, it is possible to conclude that for this narrow-groove application, these shielding levels are acceptable.

The shielding quality becomes more erratic as the joint's fill-up approaches its completion*. When welding commences near or about the baseplate's surfaces, the coverage of this torch becomes less resistant to environmental fluctuations, (wind eddies, etc.). This is evidenced from Table 2.7-2, where the impact absorbed energy of the weld deposit increases in specimens which were further removed from the baseplate's surfaces. Oxygen and nitrogen are known to adversely affect the toughness of steels.

* "Large deviation from average"

Note that the above study was done completely with the smallest cup size (#7). In recognizing the above "problem" previously, #8, #9, and #10 cups were designed and are effectively applied to maintain high quality gas shielding at the arc.

To summarize, the narrow-groove torch design used is suitable for welding the 2-1/4% Cr-1% Mo alloy (SA 387). For maximized shielding quality, maintain shortest electrode stick-outs and gas flow rates that are practically and economically feasible.

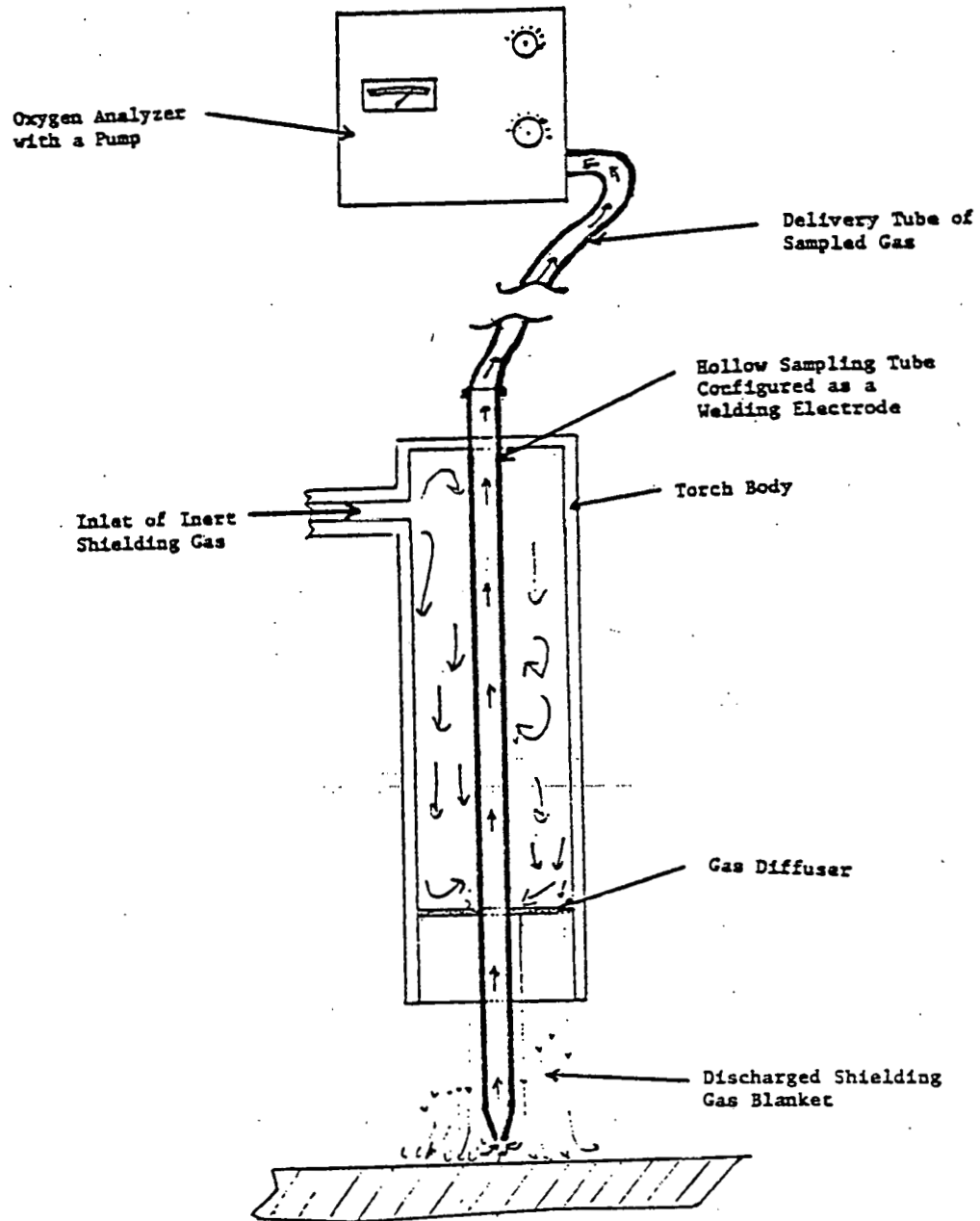

Figure 2.4-1 - System used for characterization of shielding quality delivered by the torch.

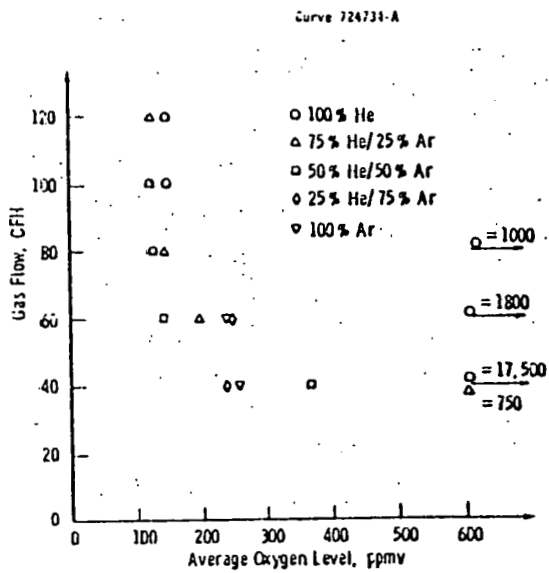

Fig. 2.4-8 - Tip No. 7, 0-Fill, Torch Altitude 0°, 1" Apparent Slick-Out, 3/16" Arc Gap, Travel Speed - 10 ipm, Preheat - 250°F, No Oscillation, Vertical (3G) Position
 Note: Slight Deviation from Average.

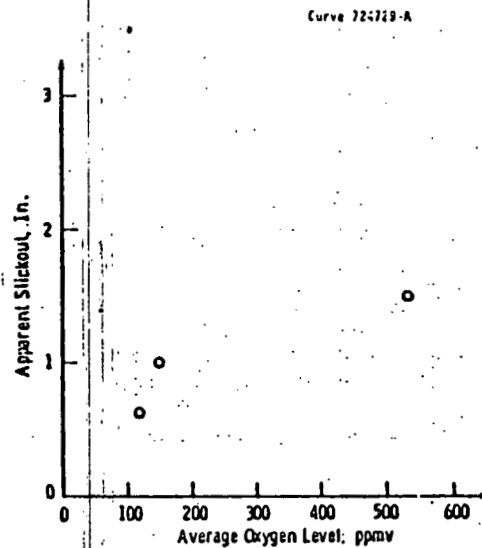

Fig. 2.4-9 - Tip No. 7, 0-Fill, Torch Altitude 0°, 3/16" Arc Gap, Travel Speed - 10 ipm, Preheat - 250°F, Flow Rate - 130 CFH (80 CFH He/50 CFH Ar), No Oscillation, Horizontal (2G) Position
 Note: Slight Deviation from Average.

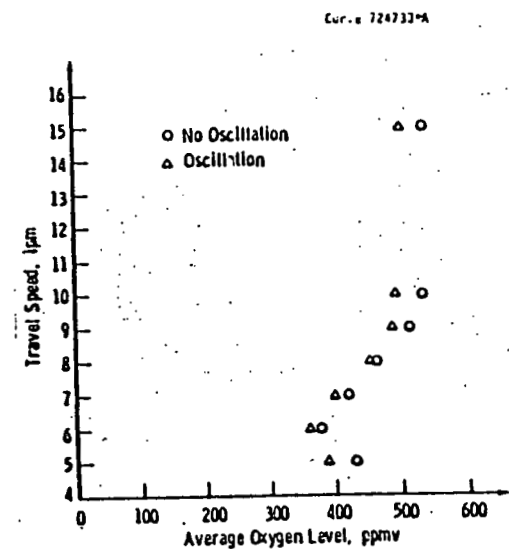

Fig. 2.4-10 - Tip No. 7, 0-Fill, Torch Altitude 0°, 1 1/2" Apparent Slick-Out, 3/16" Arc Gap, Preheat - 250°F, Flow Rate - 130 CFH (80 CFH He/50 CFH Ar), Horizontal (2G) Position
 Note: Slight Deviation from Average.

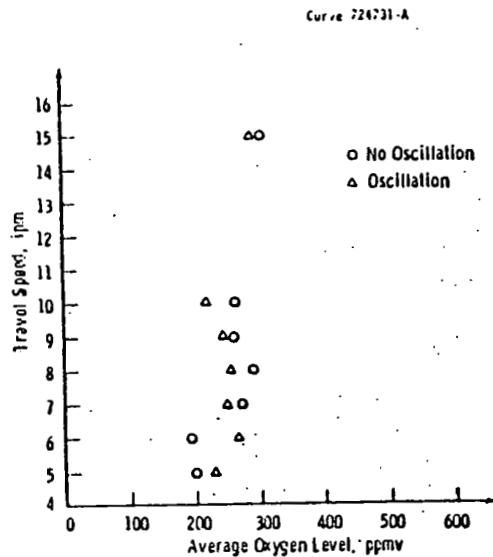

Fig. 2.4-11 - Tip No. 7, 1/2-Fill, Torch Altitude 0°, 5/8" Apparent Slick-Out, 3/16" Arc Gap, Preheat - 250°F, Horizontal (2G) Position
 Note: Large Deviation from Average

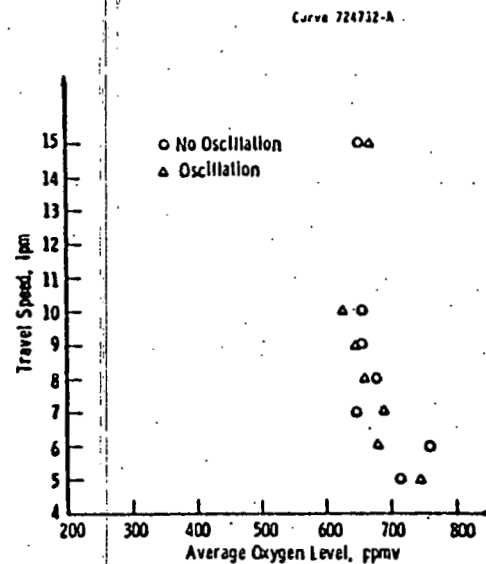

Fig. 2.4-12 - Tip No. 7, 3/4-Fill, Torch Altitude 0°, 5/8" Apparent Slick-Out, 3/16" Arc Gap, Preheat - 250°F, Flow Rate - 130 CFH (80 CFH He/50 CFH Ar), Horizontal (2G) Position
 Note: Large Deviation from Average

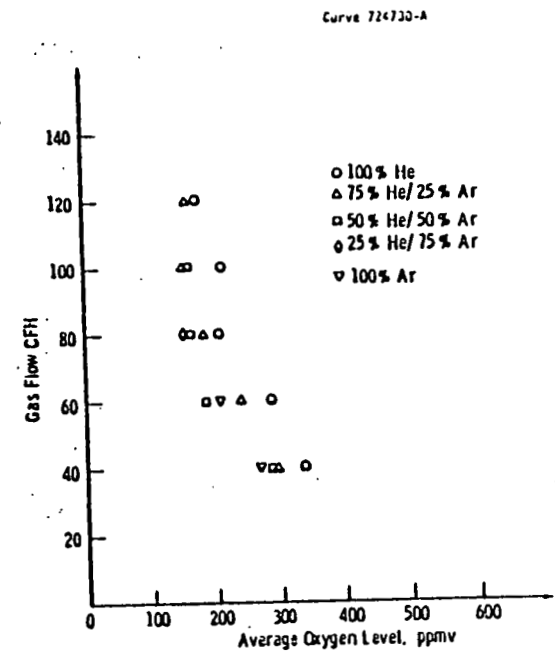

Fig. 2.4-13 - Tip No. 7, 0-Fill, Torch Altitude 0°, 1" Apparent Slick-Out, 3/16" Arc Gap, Travel Speed - 10 ipm, Preheat - 250°F, No Oscillation, Horizontal (2G) Position
 Note: Slight Deviation from Average.

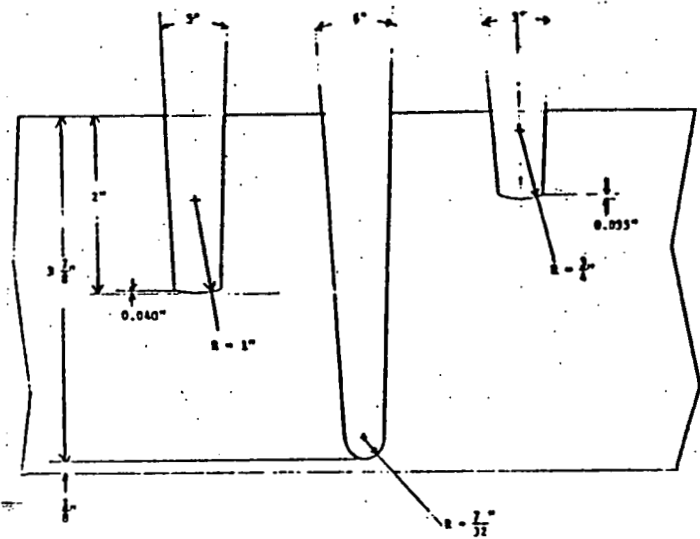

Figure 2.4-2 - Mock-up joints used in the study of shielding quality.

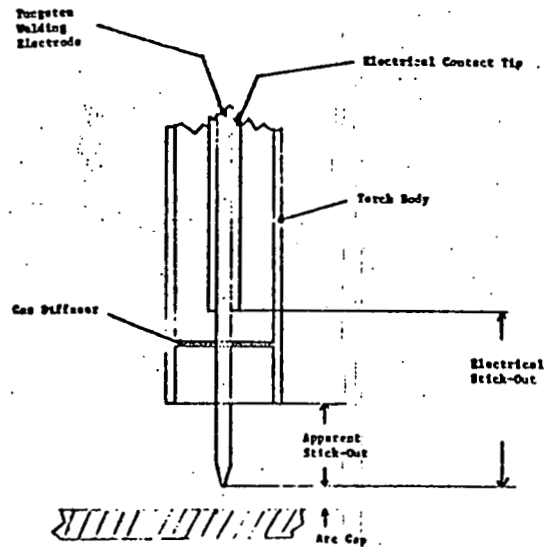

Figure 2.4-3 - Torch related notation.

Curve 724736-A

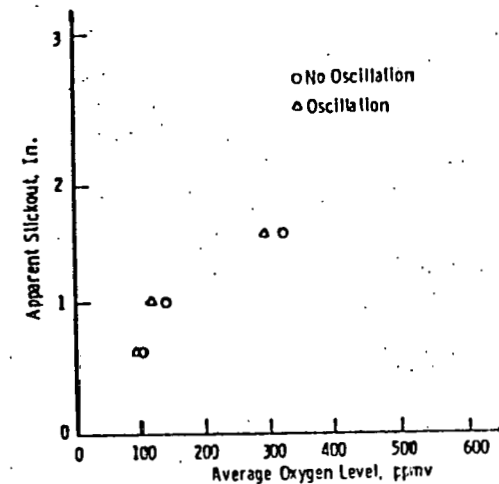

Fig. 2.4-4 - Tip No. 7, 0-Fil, Torch Altitude 0°, 3/16" Arc Gap, Travel Speed - 10 ipm, Preheat - 250°F, Flow Rate - 130 CFH (80 CFH He/ 50 CFH Ar), Vertical (3G) Position
Note: Slight Deviation from Average.

Curve 724737-A

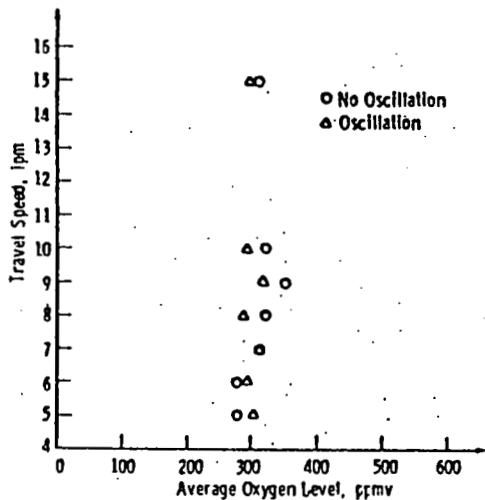

Fig. 2.4-5 - Tip No. 7, 0-Fil, Torch Altitude 0°, 1 1/2" Apparent Stick-Out, 3/16" Arc Gap, Preheat - 250°F, Flow Rate - 130 CFH (80 CFH He/ 50 CFH Ar), Vertical (3G) Position
Note: Slight Deviation from Average.

Curve 724736-A

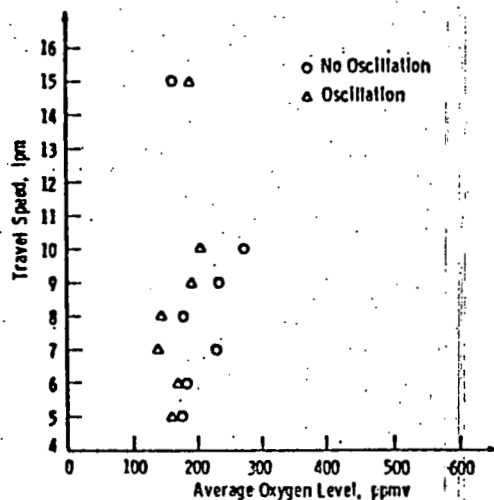

Fig. 2.4-6 - Tip No. 7, 1/2-Fil, Torch Altitude 0°, 5/8" Apparent Stick-Out, 3/16" Arc Gap, Preheat - 250°F, Flow Rate - 130 CFH (80 CFH He/ 50 CFH Ar), Vertical (3G) Position
Note: Large Deviation from Average.

Curve 724735-A

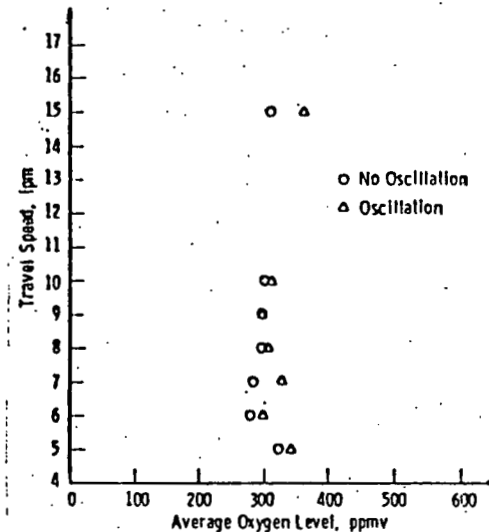

Fig. 2.4-7 - Tip No. 7, 3/4-Fil, Torch Altitude 0°, 5/8" Apparent Stick-Out, 3/16" Arc Gap, Preheat - 250°F, Flow Rate - 130 CFH (80 CFH He/ 50 CFH Ar), Vertical (3G) Position
Note: Large Deviation from Average.

2.5 PROCESS MECHANICAL CONTROL (W R&D)

2.5.1 Objective - Evaluate process control factors such as pulsing, tracking, and oscillation for heat input control, arc stabilization, mechanical integrity, and increased productivity.

2.5.2 Accomplishments:

2.5.2.1 Oscillation -

- . Minimum displacement mechanical oscillation improves wetting and feathering on both bead edges.
- . Minimum displacement mechanical oscillation is advantageous in both (2G) horizontal and (3G) vertical welding. 60/80 cycles/minute.
- . W pivoting design mechanical oscillation is superior to linear transverse oscillation.
- . More process forgiveness/margin to parametric variations.
- . More geometric and dimensional uniformity of the weld bead.
- . Magnetic oscillation is not feasible in this highly magnetic groove for space limitation does not allow a strong enough head.

2.5.2.2 Pulsing -

- . Evaluation of the pulsing aspect of mechanical control has not been initiated. It is anticipated that the root passes will be the area of greatest benefit.
- . It is anticipated that pulsed root passes will allow greater process flexibility in compensating for field joint land gaps, misalignment and local variations in land thickness.
- . Field demonstration welding system will utilize an analog pulsed circuit gated by the pivoting oscillator.

2.5.2.3 Tracking -

- . W R&D will conduct Eddy Current tracking accuracy test on narrow groove geometry.

- "Kaman Scientific" double sided non-contact Eddy Current probe with balanced bridge circuit design to maintain centerline.

2.5.2.4 The following material was included in the W R&D eighth quarterly report of this project.

"Because of the back-gouging technique adapted in welding the SA 387 baseplates, the criteria for judging acceptable root parameters became:

- (1) The ability to bridge over joint gaps and/or land mismatches.
- (2) Deposit quality conducive to subsequent welding. Namely, the root pass should possess volumetric and surface quality which when welded over, will not cause welding difficulties and defects in the following welding passes.
- (3) The deposit made with the root parameters must have sufficient "bulk" to sustain and conduct the arc force and heat inputs imposed by the following welding passes.

The welding parameters shown in Table 2.5-1 were developed on a root conditional simulator for welding a 0.150 inch thick land in the vertical (3G) position. Preliminary results on simulated root lands have proven these parameters to be capable of consistently bridging up to 0.100" root gaps.

In light of the back-gouging technique adapted, the merits of the root-parametric study are being reassessed."

TABLE 2.5.1

ROOT PASS WELDING PARAMETERS (NON-PULSING) - 3G DOWN

DC Amps	- 172.	Shield Gas:	61.5% He-38.5% Ar; 130 cfh
DC Volts	- 12.1	Oscillation:	Freq. -220 cpm; Disp. - 1/16"
AC Amps	- 13.0	Tung. Tip Geo:	Nose Dia - .040"; Inc. Angle-30°
AC Volts	- .3	Nozzle Size:	W No. 7
Wire Feed Speed	- 18 ipm	Land Thickness:	.150"
Travel Speed	- 10 ipm	Land Gap:	Up to .100"

NOTE: It is W Tampa's ultimate aim to develop the technique, joint dimensional limitations, and welding parameters to automatically weld any depth of narrow groove GTAW-HW joint from the front side without back-gouging.

This has been accomplished under production conditions by back-seal welding using manual GTAW. Then, without metal removal, welding the front full depth narrow groove by auto GTAW-HW.

NOTE (cont'd):

W Tampa has directed W R&D to complete this sub-task (2.5) and (2.6) by pulse welding (4), 1" thick, double-prepped test plates under the geometries of 2.6.2.2. These geometries and tolerances have been previously determined with GTAW-HW on low alloy steel, under production conditions.

It is hoped the root pass pulsing will extend the allowable range of joint dimensional variations and allow complete joint automatic welding.

2.5.3 Conclusions:

- 2.5.3.1 Minimum displacement mechanical pivoting oscillation will be used in both horizontal and vertical welding.
- 2.5.3.2 Manual trim for weld seam tracking will be used exclusively.
- 2.5.3.3 It is anticipated that pulsed root passes will allow greater process flexibility in compensating for field joint land gaps, misalignment and local variations in land thickness.

2.6 JOINT DESIGN (W R&D/W Tampa)

2.6.1 Objective - Evaluate adequacy of minimum volume joint design while retaining maximum margin in process reliability. Determine most effective combination of included angle, root diameter and land thickness with tolerance for each. In conjunction with root pulsing of sub-task 2.5 evaluate land gap, land-misalignment, land thickness variation.

2.6.2 Accomplishments:

- 2.6.2.1 Evaluated adequacy of six (6) joint designs starting with full accessibility and reducing toward minimum. Factors considered in this evaluation were:
 - . Arc molten puddle visibility
 - . Angular joint distortion
 - . Ease of torch and electrode manipulation within the groove.
 - . Observed gas shielding quality (bead appearance)
 - . Flexibility of parameters
- 2.6.2.2 The recommended (2G) and (3G) joint geometry is a double "U" with an included angle of $60^{\circ} \pm 1/2$ and a root radius of $7/32" \pm 1/32"$. Since machining and assembly under field conditions have a tendency to increase assembled root opening, these tolerances are not restricted.

2.6.3 Conclusions:

- 2.6.3.1 All aspects of this sub-task are complete with the exception of joint land dimensions.
- 2.6.3.2 In conjunction with pulsing studies evaluate the land thickness, root gap, and weld land misalignment.
- 2.6.3.3 Verify double "U" groove specific dimensions with completion of 8" weld thickness test plates. One (1) 8" double "U" groove complete to date - less angular distortion.
- 2.6.3.4 This 8" thick groove (Fig. 2.6.1) was welded in the 2G position with optimum groove dimensions (i.e. 6° included angle, 7/32" radius root bottom; .100" land thickness, root gap .032" local; land mismatch .062" local).
- 2.6.3.5 It was evaluated to:
 - . Verify process transition from single "U" to double "U".
 - . Verify potential for process 100% root fusion without backchip, manual backweld, grinding or arc pulsing Fig. 2.6.2.

2.7 FILLER WIRE OPTIMIZATION : (W R&D/W Tampa)

2.7.1 Objective - Survey all applicable commercially available filler wires. Consider special alloys as required. Evaluate on the basis of:

- . Weldability (feathering, wetting, bead texture, sluggishness, etc.)
- . Freedom from welding by-products (oxidation, "glass", etc.)
- . Weld deposit quality (freedom from defects).
- . Microstructure (element segregation, coarse grain - weld/HAZ, etc.)
- . Mechanical properties (cast, helix, surface finish, packaging, etc.)
- . Contract required physical properties (under Section VIII - Division 2 heat treatments).
 - . Ultimate tensile strength
 - . Yield strength (.2% offset)
 - . Elongation in 2"
 - . Reduction of area, min.

- . Metallographic examination (micro, macro & hardness)
- . Non destructive examinations
- . Material cost
- . Availability

2.7.2 Accomplishments:

- . Table 2.7 lists test results of three commercial wire chemistries under evaluation (lines 2, 3, & 4)
- . Table 2.7 lists test results of a commercial classified wire not purchased for the contract but tested for reference (line 1).
- . Table 2.7 also includes a special chemistry wire on order. Reduced from 2 to 1. (line 5).
- . Microhardness samples have been taken for preliminary data on (1) Bohler wire.
- . Transverse and longitudinal tests. (Parallel to and transverse to direction of plate rolling.)
- . Agreement with PVRC and University of Tennessee to provide 2-1/2 Cr - 1 Mo weldments for creep-rupture testing. Received plate material from PVRC. It has been welded and returned to PVRC.

TABLE 2.7 (SUMMARY)
PROPERTIES OF FILLER WIRES AND PLATE

WIRE IDENTITY	WIRE CHEMISTRY									CARBON EQUIV.	Mn/S RATIO	WELD POS.	PWHT TIME AT TEMP.	SIDE BENDS	PHYSICAL TESTING						
	C	Mn	Si	S	Cr	Mo	P	Ni	Cu						TENSILE TESTS			CHARPY IMPACT			
															T/S STR. PSI	Y/S 2% OFF PSI	ELONG. %	RED. AREA %	IMPACT FT-LBS	LAT. EXP. IN.	
1 PAGE # 47203	.080	.58	.58	.011	2.53	.98	.008	.014	.20 COATED	.520	53	20	4.0	REJECT	100,350	86,908	22.0	66.2	68.5	.027	
2 BOHLER 0305	.063	1.07	.60	.007	2.78	.91	.011	-	-	.610	163	20	4.0 [▲]	ACCEPT	100,438	86,108	23.2	66.3	35.2	.028	
												20	24.0 [●]	-	87,250	72,700	28.8	70.1	53.3	.043	
3 KOBE 9F-0561	.080	1.02	.51	.008	2.32	1.03	.013	.06	.17 COATED	.588	128	20	24.0 [●]		87,000	87,860	28.0	67.4	72.0	.059	
4 BOHLER 0407	.058	1.13	.69	.007	2.82	.94	.007	-	-	.622	161	30	4.0 [▲]	ACCEPT	88,450	75,500	24.3	67.7	38.7	.028	
												30	27.0 [▲]	ACCEPT	96,258	82,330	24.3	70.8	95.5	.072	
														ACCEPT	92,548	78,882	24.0	69.6	77.5	.062	
SPECIAL MELT CHEMISTRY DESIGNED FOR GTAW-HW																					
5 AIM 1 DEL SEPT.80	.010	.70	.30	.003	2.10	1.00	.007	-	.15 MAX	.507	188	-	-	-	-	-	-	-	-	-	
	.050	.08	.60	MAX	2.90	MAX	MAX	-	INCL COAT												

● 1" thick P-1 plate buttered with 2.25 CR-1 MO & tested as a "wire-gas" deposit evaluation, PWHT at 1275-1290° F
 ▲ 4" thick P-5 (2.25CR-1MO) non certified off-the-shelf plate of differing heats.
 ■ commercial GMAW on-the-shell wire NOT purchased for this contract.

PLATE HEAT #	PLATE CHEMISTRY									PWHT of SAMPL	PLATE PHYSICAL TESTING									
82-353-2	C	Mn	Si	S	Cr	Mo	P	Ni	Cu		TRANS.	DIR.	T/S STR.	Y/S 2% OFF	ELONG.	RED. AREA	IMPACT	LAT.		
8" PLATE TOP	.135	.570	.220	.003	2.310	.950	.008	-	-	-	190	-	24.0	TRANS.	50,400	36,200	34	73	198	.060
8" PLATE BOT.	.135	.570	.215	.003	2.312	.945	.008	-	-	-	190	-	24	DIR.	78,300	51,500	32	76	211	-
4" PLATE TOP	.135	.570	.220	.003	2.310	.965	.008	-	-	-	190	-	24.0	TRANS.	80,900	59,400	33	75	168	.083
4" PLATE BOT.	.120	.550	.220	.003	2.260	.940	.008	-	-	-	190	-	24.0	DIR.	78,800	57,000	32	76	174	.089

2.7.3 Summary:

1. Table 2.7 summarizes the physical properties of the three wire heats purchased for this contract and presently on hand. These are the two Bohler and the Kobe wires. These heats are commercial GMAW formulations.
2. The table illustrates the effect of PWHT time at temperature on the wires deposit properties. The table considers the two extremes of time at temperature; (4) hours Code minimum (for 4" plate) and 24 hours (W standard practice to allow for repair cycles).
3. Table 2.7a (below) contains additional PWHT data on the Bohler 305 deposit. This presents a good example in that all aspects of these three tests were identical except PWHT time at temperature. Note % of change of ultimate and yield strengths.
4. Graph 2.7 illustrates the shift. It also points out that the yield did not decrease sufficiently to go below the 8" plate ultimate tensile strength. Thus it indicates that the Code acceptable base plate will yield until it reaches its ultimate and fail without the excessively strong weld contributing and ductility to the joint.

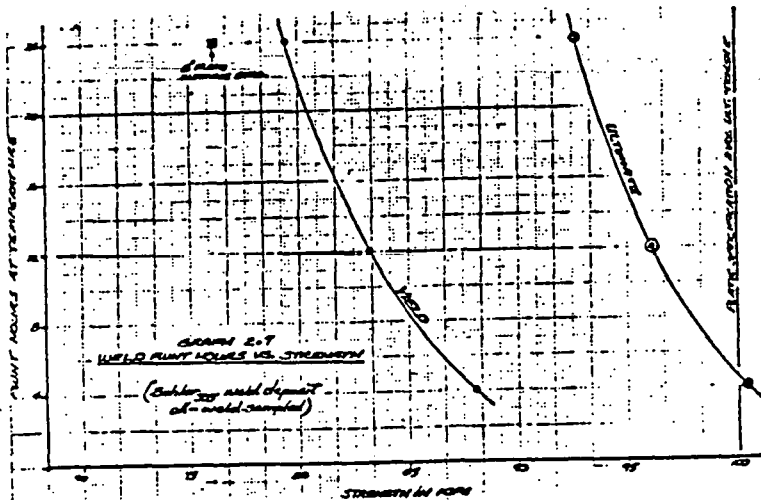

TABLE 2.7a
PWHT HOURS VS. PHYSICAL PROPERTIES

PWHT Hrs.	Ult. Ten. Str. PSI	Yield Str. PSI	Elong. %	Red. Area %	Impact Ft.-Lbs.	Lat. Exp. In.
4	100,436	88,108	23.2	68.3	35.2	.029
Diff.	4,236	4,843				
12	96,200	83,265	23.0	70.6	38.	.028
Diff.	3,355	3,891				
24	92,845	79,734	23.5	68.3	47.5	.038
Total Change %	7,511	8,734	.3	0.0	12.3	.009
	7.6	9.9	1.3	0	3.5	3.1

NOTE: Bohler₃₀₅ weld deposit all-weld sampled.

5. It is widely recognized in heavy wall fabrication that excessive strength and/or hardenability in the weld or base metal tend to increase weld metal cracks, HAZ cracks, and laminar tearing.

The more restrained and thicker the weldment, the greater the need for higher preheat and for PWHT. Excessive strength and/or hardenability in either member compounds the requirements.

If 100% joint efficiency with little or no mismatch is assured, preheat and PWHT requirements will be at their lowest required level. These are desirable field fabrication aims.

2.7.4 Conclusion:

- . The (3) "wire-gas" plates (lines 2, 3, & 4 - Table 2.7) were all identical with the exception of the wire heat used. They are, therefore, the most logical to compare for wire performance.
- . The Kobe wires deposit developed 100% joint efficiency with the least mis-match of these on-hand wires.
- . Secondary aspects of the Kobe wire evaluation such as:
 - . Weldability
 - . Freedom from welding by-products
 - . Mechanical wire characteristicsare superior to those of the two Bohler heats.
- . A specially melted wire chemistry designed for GTAW-HW, (Table 2.7 - line 5) will be available FY 81, second quarter. It will be compared with the Kobe wire.

2.8 NON-DESTRUCTIVE EVALUATION (W R&D)

2.8.1 Objective

2.8.1.1 Evaluate the field effectiveness and reliability of in-process non-destructive examinations.

2.8.1.2 Potential examination methods include:

- . Radiography (RT)
- . Liquid penetrant (PT)
- . Magnetic particle (MP)
- . Ultrasonic (UT)
- . Eddy Current (EC)
- . Acoustic Emission (AE)
- . Sonic monitoring

2.8.2 Accomplishments To Date:

- 2.8.2.1 W contracted for the technical services of a consultant for the implementation of special UT techniques for progressive inspection to the following scope:
- 2.8.2.2 Setup, calibrate and develop inspection techniques on test blocks at W Tampa, identify B.O.M. (e.g. high temperature coupling transducer, etc. for W Tampa, and W R&D ultrasonic equipment).
- 2.8.2.3 Based on the above, develop software (inspection procedure) for inspection of both 4" and 8" plate weldments.
- 2.8.2.4 Provide instructional and training services for W R&D personnel.
- 2.8.2.5 Provide technical direction for a complete progressive UT examination of one 4" test plate assembly at W R&D. This has been completed under sub-task 2.12 (3G).
- 2.8.2.6 Provide instructional and training services so that the personnel's technical ability allows them to perform independently of outside services. This is to be demonstrated on one 4" test plate at W Tampa.
- 2.8.2.7 Provide technical direction for the complete progressive UT examination of both 8" plate assemblies at W Tampa.
- 2.8.2.8 The first steps of the above scope has been in W R&D.
- 2.8.2.9 Further progressive UT examination will be conducted at W Tampa.
- 2.8.2.10 Acoustic emission monitoring has been preliminarily tested for application with the narrow groove GTAW/HW process. Results indicate that the GTAW process is too quiet - no slag.
- 2.8.2.11 The following was reported by W R&D under sub-task 2.8:

"In search for reliable inspection techniques, the magnetic particle test was found to yield misleading results when applied to nonheat-treated 2-1/4% Cr - 1% Mo weld deposits.

A magnetic particle test, operated at DC mode and 1000 amperes, was used for detection of surface and sub-surface weld defects. Depending upon the orientation

of the induced electromagnetic flux lines, the test persistently revealed somewhat diffused indications which exactly coincided with weld/weld and weld/base-plate tie-in areas.

UT inspection, radiography, careful microscopic scanning and dye penetrant test showed the samples to be very sound. But when the same test was applied to a postweld stress-relieved weld, no defect indications were found.

It is postulated that the magnetic properties, such as magnetic permeability, of certain regions in the deposit are altered by either thermal cycles and/or microsegregational mechanisms that commence during solidification. The grain refined and fusion line regions are most prevalent about the tie-in areas.

To summarize, the magnetic particle test can be used for inspecting only postweld stress-relieved weldments."

2.8.3 Conclusion:

2.8.3.1 The above ultrasonic testing techniques have been previously applied under field conditions on 4" plate. 8" plate may require extension of these techniques.

2.8.3.2 Under this contract (para. 2.8.2.5) these in-process UT techniques have now been successfully applied to a 4" test plate assembly.

2.9 REPAIR TECHNIQUES (W R&D)

2.9.1 Objectives:

2.9.1.1 Qualify a practical on-line repair capability.

2.9.1.2 Demonstrate the repair techniques in the horizontal and vertical positions by removing sections of completed welds and repairing them.

2.9.1.3 Test repairs for quality - optimize procedure for reliability.

2.9.1.4 Deliver a repair procedure (software - W Tampa format).

2.9.2 Accomplishments:

2.9.2.1 The following was reported by W R&D under sub-task 2.9:

"Special mock-up joints to simulate a repaired joint have been designed and submitted for machining. Few potential weld sequences were reviewed as possible candidates to be applied for weld repair."

2.9.3 Conclusion

2.9.3.1 No conclusion

2.11 HORIZONTAL POSITION PARAMETERS (W R&D)

2.11.1 Objectives:

2.11.1.1 To establish recommended horizontal position process parameters with their ranges.

2.11.1.2 Demonstrate the validity of these parameters in the (2G) welding of a 4" thick, 48" long test plate, using the preferred filler wire of sub-task 2.7.

2.11.1.3 Employ the recommended in-process inspection system of sub-task 2.8; and after PWHT, the recommended inspection system of the same sub-task.

2.11.1.4 Physical test to equal or exceed the plate properties of specification 2652A59. The testing shall include the following (after the PWHT per paragraph 2.3 of the specification):

- . Two test sections of longitudinal and two of transverse tensiles @60°F (16°C) and 600°F (326°C).
- . Two test sections of drop weights @ 60°F (16°C), both from weld and the HAZ.
- . Three test sections of "Vee" notch charpies @ 60°F (16°C) from the weld and the HAZ. (Section VIII - Division 2, Article T-2).
- . Four test sections of the transverse side bends.
- . One macro section with hardness 1/4T from the top, 1/4T from the bottom and from the center.
- . One micro section for metallographic characterization.
- . One weld chemistry block taken from the 1/2T location and tested for: C, Mn, P, S, Si, Cr, Mo, Ni and Cu.

2.11.2 Accomplishment:

2.11.2.1 The interactive balance of the parameters has been well established.

2.11.2.2 Several trial test plates have been welded, PWHT'd and tested.

2.11.2.3 These results are tabulated under sub-task 2.7 of this report.

2.11.3 Conclusion:

2.11.3.1 The final 4" thick - 48" long demonstration, using specification plate, has not been accomplished.

2.12 VERTICAL POSITION PARAMETERS (W R&D)

2.12.1 Objective:

2.12.1.1 Establish vertical position process parameters with their ranges.

2.12.1.2 Demonstrate the validity of these parameters in the (2G) welding of a 4" thick, 48" long sample test plate, using the preferred filler wire as determined in sub-task 2.7.

2.12.1.3 Employ the recommended in-process inspection system as determined in sub-task 2.8; including the after PWHT inspection system of the same sub-task.

2.12.1.4 Physical testing should equal or exceed the plate properties of specification 2652A59. The testing shall include the following (after PWHT per paragraph 2.3 of the specification):

- . Two test sections of the longitudinal and two test sections of the transverse tensiles @ 60⁰F (16⁰C) and 600⁰F (326⁰C).
- . Two test sections of drop weights at 60⁰F (16⁰C) and 600⁰F (326⁰C).
- . Two test sections of drop weights @ 60⁰F (16⁰C) both from the weld and the HAZ.
- . Three test sections of "Vee" notch charpies @ 60⁰F (16⁰C), both from the weld and the HAZ. (Section VIII - Division 2, Article T-2).
- . Four test sections of the transverse side bends.
- . One macro section with hardness transverse 1/4T from the top and 1/4T from the bottom and from the center.
- . One micro section for metallographic characterization.
- . One weld chemistry block taken from the 1/2T location and tested for: C, Mn, P, S, Si, Cr, Mo, Ni and Cu.

2.12.2 Accomplishment:

- 2.12.2.1 Vertical position evaluation of techniques and parameters has progressed to the completion and PWHT of the first trial test plates.
- 2.12.2.2 Table 2.7 - line 4 (under 3G position) summarizes vertical down test results to date, this test plate had 1/2 PWHT'd (4) hours and the balance (27) hours.
- 2.12.2.3 The following material was included in the W R&D eighth quarterly report of this sub-task:

"For weld procedure qualification, 48" long and 4" thick pedigree baseplates were welded. The joint consisted of a 6° included angle, 7/32" root radius and 1/4" land thickness. Approximately every inch of deposited weld was UT inspected with 45° and 60° shear angle under the supervision of Mr. Claude Galyen, an NDE level III inspector, contracted by the Tampa Plant. As welding progressed, longitudinal UT examination from the plate ends, 90° to the weld, was also carried out. The results showed the entire inspectable portion of the weld to be free of weld defects (Appendix I and II). In addition, the entire welding operation was continuously monitored by a two probe acoustic emission system, operated by engineers from the Gard, Inc. Although the system's gain was set to maximum sensitivity, the weld generated "extraordinarily low acoustic activity" (*).

Table 2.12-1 gives the welding parameters used in welding the pedigree baseplates. Strict adherence to these conditions is insufficient to assume a successful welding operation. The judgment of a skilled operator is an integral part of this effort.

As the welding approached completion and the inert gas mixture (75% He, 25% Ar) was not well confined as it was in the narrow groove, severe shielding difficulties arose. (**) The visibility of the arc and molten pool was obliterated by heavy smoke generated at the arc vicinity. As a result, the welding operator experienced difficulties in properly placing

* David W. Prine, Manager, Nondestructive Testing Systems, Gard, Inc.

** As previously noted, W R&D used the smallest size gas nozzle throughout this 3G weldment. The reported shielding difficulties point out the necessity of using the proper nozzle size.

the molten pool relative to the previous welding pass at the wire into the molten pool. Also, instabilities in arc characteristics caused weld deposits to become geometrically inconsistent. The tungsten electrode was replaced after every welding pass since its tip was heavily oxidized and interpass cleaning involved removal of an unusually heavy oxide.

The next order of steps for the 3G weldment are:

- (1) Remove strongbacks (Figure 2.12-1).
- (2) "Back-machine" a joint to virgin metal from the back face of the weldment (Figure 2.12-2). Dye penetrant inspection will be applied to assure the soundness of the weld deposit.
- (3) Machine the weld's reinforcement "flush" with the front face of the weldment (Figure 2.12-2) to a 250-500 RM surface finish.
- (4) Weld the back joint made in Step 2.
- (5) Postweld stress-relief the assembly.
- (6) Machine the weld's reinforcement "flush" with the back face of the weldment.
- (7) Radiograph the weld.
- (8) Conduct a final UT inspection.
- (9) Remove specimens for mechanical testing."

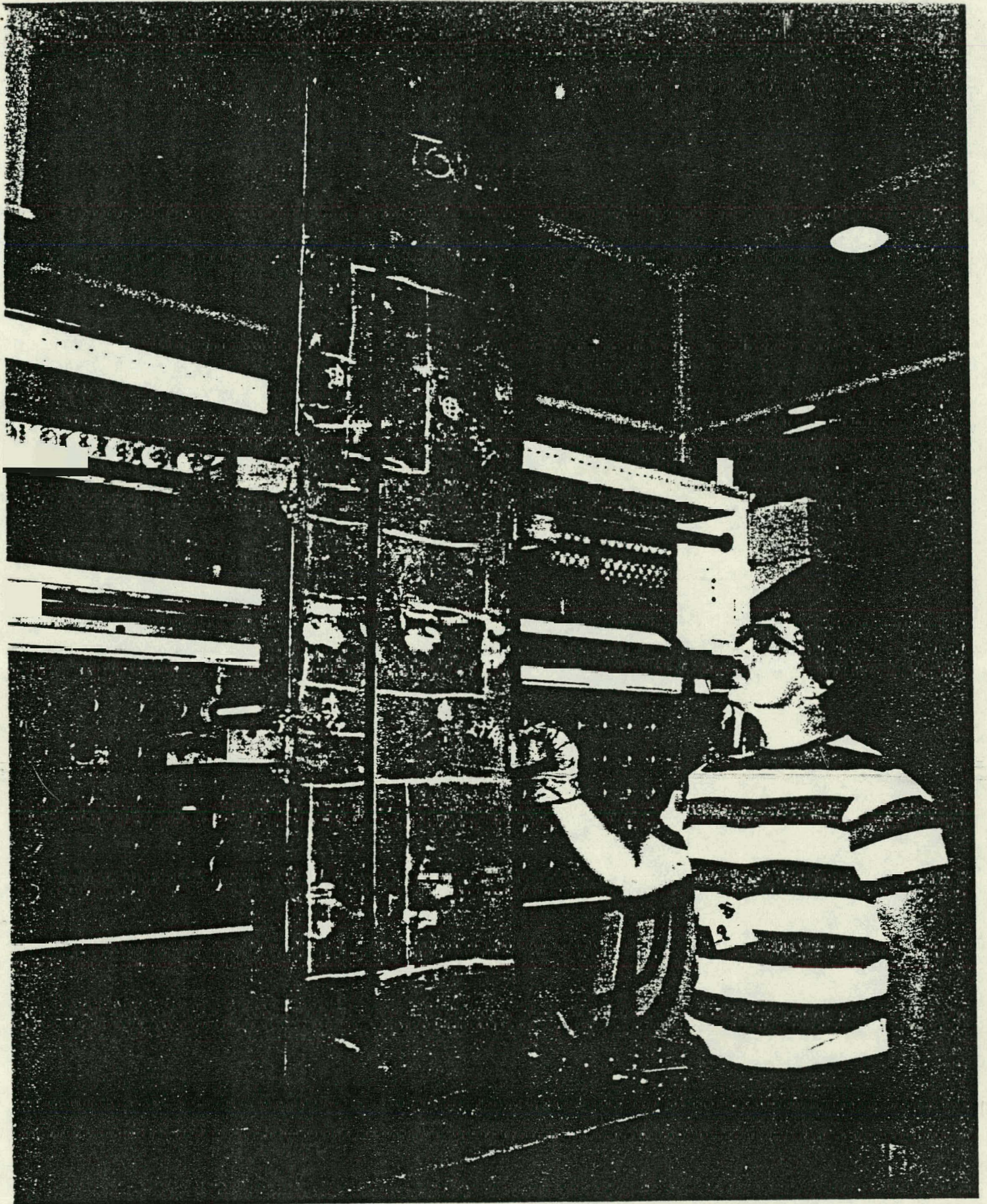

Figure 2.12-1 - Weldment and strongbacks for joint restraint against premature closing.

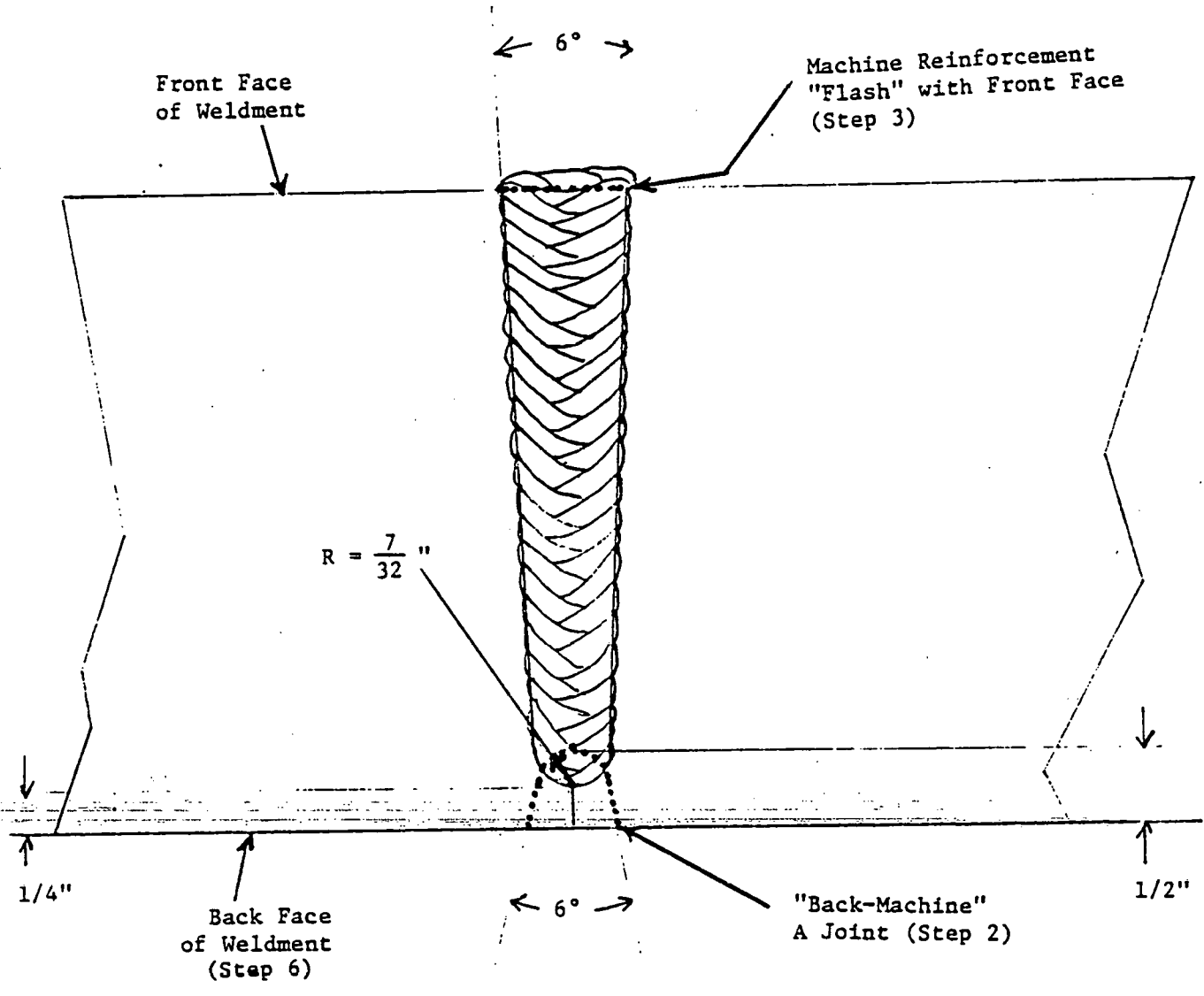

Figure 2.12-2 - Next machining steps on the qualifying weldment.

NARROW GROOVE WELDING UT RESULTS

DOE Contract #DE-ACOS-78OR13511 at R&D

C. A. Galyen

September 4, 1980

Approximately one inch of deposited weld metal on the first procedure test block was UT examined on 9/4/80. The UT examination was performed using the 45° and 60° shear angles. The results showed the weld to be apparently free of welding indications although the backchip groove reflections did interfere with the interpretations.

September 5, 1980

Approximately 2 inches of weld metal. The 45° and 60° shear angle examination showed no apparent indications. Longitudinal examination from the plate end, 90° to the weld, was also clear.

September 8, 1980

Approximately 3 inches of deposited weld metal on the above test block was UT examined on 9/8/80. The UT examination was performed using 45° and 60° shear angles and showed no apparent indications. The longitudinal examination from the plate end was also clear.

September 9, 1980

Approximately 3/16 in. from flush with top. Results same as above.

2.12.3 Conclusion:

2.12.3.1 Using the preferred filler wire and the 4" thick 48" long certified plate, perform the procedure qualification.

2.13.3.2 Employ all recommended non-destructive in-process and final examination techniques.

2.13.3.3 PWHT 24 hours at temperature and physically test.

2.13 MECHANICAL TESTING AND QUALIFICATION (W R&D)

2.13.1 Objective:

2.13.1.1 Test and report the plate physical properties (see Accomplishments 2.13.2) below.

2.13.1.2 Test and report the 4" demonstration test plate of sub-task 2.11 and 2.12 (see paragraphs 2.11.1.4 and 2.12.1.4 in connection with the sampling).

2.13.1.3 Develop a weld procedure specification (WPS) using the W Tampa format. Include all the requirements of QW256 (GTAW using notch tough base material).

2.13.1.4 Develop a procedure qualification record (PWR) using the W Tampa format and forms. Document the techniques, parameters and test results of either sub-task 2.11 or 2.12. Include all the requirements of QW 256 (GTAW using notch tough base material).

2.13.2 Accomplishment:

2.13.2.1 The certified 4" test plate (W specification 2652A59) has been tested to all requirements of the contract and it will not, in itself, need further testing. The suppliers' certification and test results are included in this quarterly report below:

3.3 (DEMONSTRATION FACILITY) FIELD ASSEMBLY ASSESSMENT (W TAMPA)

3.3.1 Objective --

- 3.3.1.1 Assess the field methods of sub-tasks 3.2.
- 3.3.1.2 Determine which do not need duplication.
- 3.3.1.3 Develop demonstration facility equipment concepts.
- 3.3.1.4 Provide necessary specifications to support an equipment RFQ.
- 3.3.1.5 Send out the RFQ to the equipment sub-contractor and review his proposal requesting revisions as required.
- 3.3.1.6 Issue the approved purchase order based on the acceptable proposal.

3.3.2 Accomplishment -

- 3.3.2.1 The design of the simulated field demonstration facility is based on an analogy of the above field sequence concepts.
- 3.3.2.2 Pertinent key areas of this design are made as facsimile of the field production equipment.
- 3.3.2.3 The simulated field demonstration weld equipment concept are developed in a series of eight sketches (FY-79, fourth quarter report).
- 3.3.2.4 ~~Specifications to support and RFQ have been developed.~~
These consist of the following:
 - . Work scope
 - . Equipment specification
 - . Concept sketches
 - . Bills of materials
- 3.3.2.5 An RFQ has been sent to the equipment contractor.
- 3.3.2.6 An acceptable P.O. Specification to W has been negotiated.

3.3.3 Conclusion -

- 3.3.3.1 The assessment of the demonstration facility and the demonstration unit is as follows:

- . The weld arc (from field concepts) is isolated from any hostile field environment. Consequently the demonstration facility will be located inside a building and not subject to adverse environmental conditions.
- . Weld prep milling capability need not be demonstrated. Previous experience in production utilized similar track-mounted milling apparatus.
- . Alignment of the carriage and tracks to the workpiece is a duplication of field concepts.
- . Electronic and electrical equipment packaging duplicates the environmentally sealed field concepts including moisture tight cable connections.
- . Shielding gas manifolding, distribution and quality monitoring duplicates site concepts.
- . All process aspects (i.e. preheating, welding, parameters, heat treating, inspection, etc.) shall be according to the process specification called for in task 4.0
- . The complete flow of operations of the simulated field demonstration weldment shall be documented and QA verified on a Weld Test Plate Routing Form.

3.3.3.2 The formal P.O. to procure the demonstration facility welding equipment has been submitted to DECASMA - Orlando for approval and has been approved.

3.3.3.3 The P.O. has been issued to the vendor -- equipment delivery date is March 31, 1981.

3.4 POST WELD HEAT TREATMENT (W Tampa)

3.4.1 Objectives:

- 3.4.1.1 Determine the type of heating, control and insulation consistent with the field fabrication, as well as the demonstration facility.
- 3.4.1.2 Develop a preheat/interpass and PWHT specification.
- 3.4.1.3 Draft an RFQ based on the above specifications.
- 3.4.1.4 Issue a P.O. to a field heat treatment subcontractor.

3.4.2 Accomplishment:

- 3.4.2.1 Westinghouse field construction, repair and alteration experience has found electrical resistance heating effective with sufficient field contractors available.
- 3.4.2.2 An RFQ has been drafted.

3.4.3 Conclusion -

3.4.3.1 No conclusion.

3.5 FILLER WIRE PROCUREMENT (W R&D/W TAMPA)

3.5.1 Objective -

3.5.1.1 From previous W GTAW-HW experience, determine the preferred wire chemistry.

3.5.1.2 Select the most suitable commercially-available wire heats in sufficient quantity for the full contract, (same heat as for sub-task 2.7).

3.5.1.3 If proper deposit results are not obtained, modify the wire chemistry as needed and order special heats.

3.5.1.4 Draft a wire specification (using the W Tampa format) satisfying the requirements of the optimum wire chemistry.

3.5.2 Accomplishment -

3.5.2.1 Three commercial heats (selected chemistries) have been obtained for both this and sub-task 2.7.

3.5.2.2 An additional (special melt) heat's chemistry has been developed and ordered.

3.5.3 Conclusion -

3.5.3.1 Initial test results indicate the ultimate tensile strength of the weld exceeds the maximum of the plate specification. (~~Commercial GMAW type wire~~).

3.5.3.2 A special chemistry heat designed for GTAW-HW is needed to achieve 100 joint efficiency with minimum properties mismatch.

3.5.3.3 Sub-tasks 2.7 and 3.5 are combined - see sub-task 2.7.4 for detailed conclusion.

3.6 EQUIPMENT QUALIFICATION (W Tampa)

3.6.1 Objective -

3.6.1.1 System check-out and verification to be accomplished at the supplier's facility.

3.6.1.2 The supplier is to furnish technical assistance in the reassembly of the demonstration equipment in W Tampa.

3.6.1.3 The supplier shall provide welding system verification checkout at W Tampa and integrate with gas distribution, services, and W Tampa facility arrangement.

3.6.2 Accomplishment -

3.6.2.1 No accomplishments

3.6.3 Conclusion -

3.6.3.1 No conclusion

3.7 FULL SECTION PROCESS REFINEMENTS (W Tampa)

3.7.1 Objective -

3.7.1.1 Since the GTAW-HW equipment in the W R&D lab is not designed to simulate the field welding conditions and the equipment of W Tampa is, there may be discrepancies develop that apply in one instance, but not in the other. Among those differences that are know to apply are (4" vs. 8" plate):

- . Heat sink
- . Weld shrinkage
- . Magnetism
- . Grounding direction/fields
- . Bead sequence/wire/placement

3.7.1.2 Modification to the hardware and process refinements will be identified and implemented as required.

3.7.2 Accomplishment -

3.7.2.1 W Tampa equipment has been adapted to weld short length 8" plate material in the (2G) horizontal position.

3.7.2.2 A retrofit tooling design has been developed for the W Tampa lab unit to enable short length vertical (3G) welding.

3.7.2.3 Preliminary weld shrinkage, distortion, data has been obtained from the 1st 8" test plate.

3.7.2.4 Other parametric observations, heat sink, magnetism, bead sequence etc. is now available - useful for full scale refinements.

3.7.3 Conclusion -

3.7.3.1 No conclusions

3.8 FINALIZE WELD PROCEDURES (W Tampa

3.8.1 Objective--

3.8.1.1 Draft a weld process specification (on W Tampa format) documenting all applicable requirements of ASME Section VIII-Div. 2 and Section IX.

3.8.1.2 Subjects in the weld process specification shall include:

- . Scope
- . Process euqlification (codes)
- . Safety requirements
- . Materials classification
- . Qualification of operators
- . Welding materials
- . Equipment
- . Preparation for welding
 - . Joint geometry
 - . Alignment tolerance
 - . Cleaning
- . Heating parameters
 - . Preheat
 - . Interpass
 - . Post Heat
 - . PWHT
- . Welding parameters and techniques
- . Position
- . Equipment set-up techniques
- . Welding techniques
- . Examination
- . Repair welding
 - . Automatic GTAW-HW
 - . Manual GTAW

3.8.2 Accomplishments -

3.8.2.1 No accomplishments

3.8.3 Conclusion -

3.8.3.1 No conclusion

3.9 FIELD SITE PREPARATION (W Tampa)

3.9.1 Objective -

3.9.1.1 Provide all temporary services:

- . Lifting capability
- . Power
- . Air
- . Water
- . Shielding gas
- . Heating capability
- . Deck surface
- . Environmental shielding
- . Test plate supporting fixture
- . Operator scaffolding

3.9.1.2 Install heating and environmental equipment.

3.9.2 Accomplishment -

3.9.2.1 Sub-task 3.2.3.2 draws the following conclusions:

- . the facility may be set-up inside a building
- . all services are essentially available
- . environmental conditions are similar
- . equipment design head travel, alignment similar
- . adaptation of existing GTAW-HW is straight forward

3.9.3 Conclusion -

3.9.3.1 All field site preparations are complete, with the exception of the preheating and PWHT capability.

- 3.9.3.2 Preheating and PWHT capability will be provided by a field heat treatment sub-contractor.
- 3.9.3.3 All physical source services have been verified.
- 3.9.3.4 A gas distribution and monitoring system has been designed for adaptation to the welding system at W Tampa. An RFQ has been issued, quotations complete.

3.10/HORIZONTAL AND VERTICAL FIELD DEMONSTRATION WELDING AND HEAT

3.11 TREATMENT: (W Tampa)

3.10.1 Objective -

3.10.1.1 Demonstrate and qualify the horizontal and vertical GTAW-HW welding (double preped 8" plate).

3.10.1.2 Factors to be considered:

- . loading and tack welding
- . temporary attachments
- . runoff clips
- . heaters and thermocouples (in-process and PWHT).
- . NDT (in-process and final)
- . fixturing
- . mass simulation
- . equipment profile/obstructions
- . environment
- . human engineering aspects
- . process parameters

3.10.2 Accomplishment -

3.10.2.1 No accomplishments

3.10.3 Conclusion -

3.10.3.1 No conclusion

3.12 NON-DESTRUCTIVE EVALUATION (W Tampa)

3.12.1 Objective -

3.12.1.1 During the welding of sub-tasks 3.10/3.11, continuous monitoring will be performed.

3.12.1.2 These techniques will include:

- . Continuous fiber optics
- . Ultrasonic examination at each shift's end
- . Essential parameters will be observed and recorded.

3.12.1.3 Other non-destructive test that may be used at various stages of the operation are:

- . Liquid penetrant
- . Magnetic particle
- . Ultrasonics
- . Radiography

3.12.1.4 After completion, the faces are to be magnetically and ultrasonically examined.

3.12.1.5 After PWHT the weld will be radiographed.

3.12.2 Accomplishment -

3.12.2.1 No accomplishments

3.12.3 Conclusion -

3.12.3.1 No conclusions

3.13 MECHANICAL TESTING - DEMONSTRATION WELDS (W Tampa)

3.13.1 Objective -

3.13.1.1 Physical test to equal or exceed the plate properties of specification 2652A59. The testing shall include the following (after the PWHT per paragraph 2.3 of the specification):

- . Two test sections of longitudinal and two of transverse tensiles @ 60^oF (16^oC) and 600^oF (326^oC).
- . Remove sufficient drop weight coupons to determine Nil Ductility Transition Temperature.
- . Sufficient charpie "Vee" notch specimens from base material, HAZ and weld with a resultant transition curve plot. Specifically test (3) weld specimens @ 60^oF (16^oC).
- . Four test sections of the transverse side bends.
- . One macro section with hardness 1/4T from the top, 1/4T from the bottom and from the center.

- . One micro section for metallographic characterization.
- . One weld chemistry block taken from the 1/2T location and tested for: C, Mn, P, S, Si, Cr, Mo, Ni, and Cu.

3.13.2 Accomplishment -

3.13.2.1 Limited all weld metal testing of "wire-gas" (three commercial wire heats) deposits to evaluate the effect of PWHT time at temperature on (specific wire chemistry) deposit physical properties.

3.13.2.2 Joint design geometry evaluations (primary macro sections) supporting sub-task 2.6.

3.13.3 Conclusion -

3.13.3.1 No conclusions

3.14 WELD DEMONSTRATION REPORT (W TAMPA)

3.14.1 Objective

3.14.1.1 Deliver the required procedure qualification records (PQR). They will satisfy all requirements of Section IX of the ASME Code.

3.14.2 Accomplishment -

3.14.2.1 No accomplishments

3.14.3 Conclusion -

3.14.3.1 No conclusions

4.1/ PROCESS SPECIFICATION AND OPERATIONAL MANUAL (W Tampa)
4.2

4.1.1 Objective

4.1.1.1 The process procedure handbook will include:

- . The equipment specifications (equipment supplier's proposal)
- . The operating instructions
- . The equipment operating manual
- . The trouble-shooting/repair manual
- . The process specifications (WPS)
- . The base material specification

- . The welding wire specification
- . The shielding gas specification

4.1.2 Accomplishment -

4.1.2.1 No accomplishments have been made with regard to the handbook, however, a revised listing of objectives is as below based on the equipment specification of sub-task 3.3:

- . Equipment Operating Instructions
 - . Functional sequence diagram
 - . Mechanical assembly sequence
 - . Utility services required
- . Maintenance and Trouble-shooting Manual
 - . Logic diagrams
 - . Symptom-cause-remedy
 - . Circuit logic matrix
 - . Recommended spare parts
- Operational Manual (photos and sketches as required)
 - . Weld equipment functional diagrams
 - . ~~Track and pin lock system~~
 - . Test plate fixture
 - . Welding power supply and control center
 - . Remote optical surveillance system
 - . Gas quality monitoring system
 - . Power, signal, festoon cables, and inter-connect lines
 - . Use of software programs to verify trouble-shooting analysis
- . The Process Specification (WPS)
 - . The base material specification
 - . The welding wire specification
 - . The shielding gas specification

4.1.3 Conclusion -

4.1.3.1 No conclusions

TASK	DESCRIPTION	PLANNED COMPLETION DATE	ACTUAL COMPLETION DATE	COMMENTS
1.0	REVIEW OF CURRENTLY AVAILABLE WELD PROC. AND PROJ. PLANNING			
1.1	Project Planning	4/1/79	3/20/79	
1.2	Welding Processes Review	8/1/79	3/28/80	
2.0	DEVELOPMENT OF PROC. AND LABORATORY DEMONSTRATION			
2.1	Consultation	4/1/80		
2.2	Facility Rearrangement	2/1/79	12/31/78	
2.3	Materials Procurement	10/1/79	5/14/80	Materials up to 4" thickness received and in use. 4" material combined with 3.1 - extended to 4/30/80.
2.4	Torch and Shield Adaptation	6/1/79	6/29/79	
2.5	Process Mechanical Control	11/1/79		Extended to 6/1/80 result of late plate delivery of 2.3.
2.6	Joint Design Evaluation	11/1/79		Extended to 6/1/80 result of late plate delivery of 2.3.
2.7	Filler Wire Optimization	7/1/80		Complete optimization of wire with present heats to complete (9/15/80). Move special melt wire to sub- task 3.7.
2.8	Non Destructive Evaluation	11/1/79	9/16/80	Extended to 10/28/80 result of late plate delivery of 2.3.
2.9	Repair Techniques	5/1/80		Extended to 10/28/80 result of late plate delivery of 2.3.
2.10	Flat Position Parameters	8/1/79	3/29/80	
2.11	Horiz. Position Parameters	10/1/79		Extended to 7/28/80 result of late plate delivery of 2.3.
2.12	Vert. Position Parameters	7/1/80	9/16/80	Extended to 9/15/81 result of late plate delivery of 2.3.
2.13	Mechanical Testing & Qual.	8/1/80		Extended to 12/15/81 result of late plate delivery of 2.3
2.14	Quarterly Report & Final Task Report	As Req'd	As Req'd	Quarterly Reports: Jan., April, July, Oct. Final Report: 10/1/80

MILESTONE LOG

TASK	DESCRIPTION	PLANNED COMPLETION DATE	ACTUAL COMPLETION DATE	COMMENTS
3.0	FIELD DEMONSTRATION			Vendor delivery scheduled for 4/30/80.
3.1	Material Procurement	6/1/80	5/14/80	
3.2	Plan for Demonstration Facility	1/1/80	9/30/79	
3.3	Demo Facility - Field Assembly Assessment	6/15/80		Extended negotiations with supplier is moving out equipment tentative delivery date (11/1/80) Scope error - field heat treatment sub-contractor must be present during demo. welding. Additional heats may have to be evaluated - move completion to 1/1/81.
3.4	Post Weld Heat Treatment	8/1/80		
3.5	Procure Filler Wire	4/1/80		
3.6	Equipment Qualification	9/1/80		
3.7	Full Section Process Refinements	1/1/81		WTP may have to do a special wire heat evaluation.
3.8	Finalize Demonstration Procedures	4/1/81		
3.9	Field Site Preparation	1/1/81		
3.10	Horiz. Position Welding PWHT	6/1/81		
3.11	Vert. Position Welding PWHT	8/1/81		
3.12	Non Destructive Evaluation	9/1/81		
3.13	Mechanical Testing - Demonstration Welds	9/1/81		
3.14	Weld Demonstration Report	9/28/81		
3.15	Quarterly Reports	As Req'd		Quarterly Reports: Jan., April, July, Oct.
4.0	WELDING PROCESS PROCEDURE HANDBOOK			Final Report 10/1/81
4.1	Process Specification	6/1/81		
4.2	Operation Manual	9/28/81		

U.S. ENERGY RESEARCH AND DEVELOPMENT ADMINISTRATION

MILESTONE PLAN AND MANAGEMENT REPORT

1. Contract Identification		2. Reporting Period		3. Contract Number											
DEVELOPMENT OF AUTOMATED WELDING PROCESS FOR FIELD FABRICATION OF THICK WALLED PRESSURE VESSELS		6/29/80 through 9/28/80		DE-AC05-78OR13511											
4. Contractor (Name, address)		5. Contract Start Date		6. Contract Completion Date											
WESTINGHOUSE ELECTRIC CORPORATION NUCLEAR EQUIPMENT DIVISIONS P.O. BOX 19218 TAMPA, FLA. 33626		09-29-78		09-28-81											
7. Milestone Number	8. Reporting Category (e.g., contract line item or work breakdown structure element)	9. Fiscal Years and Months												10. Percent Complete	
		FY 79				FY 80				FY 81					
		01	02	03	04	01	02	03	04	01	02	03	04		
1.0	REVIEW OF CURRENTLY AVAILABLE WELD PROC. AND PROJ. PLANNING														
1.1	Project Planning	→													100
1.2	Welding Processes Review	→				▼									100
2.0	DEVELOPMENT OF PROCESS AND LABORATORY DEMONSTRATION														
2.1	Consultation		△		△	△	△								
2.2	Facility Rearrangement	→													100
2.3	Materials Procurement	→				△									100
		(4" Material Combined With 3.1)													
2.4	Torch and Shield Adaptation	→				▼									100
2.5	Process Mechanical Control	→				△		◇							80
2.6	Joint Design Evaluation	→				△		◇							85
2.7	Filler Wire Optimization	→				△		◇							70
		(complete optimization with present (3) heats - move evaluation of (2) special melt heats to sub-task 3.7)													
2.8	Non Destructive Evaluation	→						◇							100
2.9	Repair Techniques					→	△		◇						10
2.10	Flat Position Parameters	→				▼		◇							100

11. Signature of Contractor's Project Manager and Date

12. Signature of Government Technical Representative and Date

U. S. ENERGY RESEARCH AND DEVELOPMENT ADMINISTRATION
MILESTONE PLAN AND MANAGEMENT REPORT

1. Contract Identification DEVELOPMENT OF AUTOMATED WELDING PROCESS FOR FIELD FABRICATION OF THICK WALLED PRESSURE VESSELS	2. Reporting Period 6/29/80 through 9/28/80	3. Contract Number DE-AC05-78OR13511
(Contractor Name, address) WESTINGHOUSE ELECTRIC CORPORATION NUCLEAR EQUIPMENT DIVISIONS P.O. BOX 19218 TAMPA, FLA. 33626	5. Contract Start Date 09-29-78 6. Contract Completion Date 09-28-81	

Itemization Number	B. Reporting Category (e.g., contract line item or work breakdown structure element)	D. Fiscal Years and Months																E. Percent Complete
		FY 79				FY 80				FY 81								
		01	02	03	04	01	02	03	04	01	02	03	04					
2.11	Horiz. Position Parameters				▲				◇									85
2.12	Vert. Position Parameters								◇									100
2.13	Mechanical Testing & Qual. (Quarterly Report & Final Task Report)								▲									30
2.14		▲	▲	▲	▲	▲	▲	▲	▲	▲	▲	▲	▲					
3.0	FIELD DEMONSTRATIONS																	
3.1	Material Procurement								▲									100
3.2	PLAN FOR- Demonstration Facility								▲									100
3.3	DEMO FACILITY - Field Assembly Assessment								▲									85
3.4	Post Weld Heat Treatment																▲	10
3.5	Procure Filler Wire								▲								◇	80
3.6	Equipment Qualification								▲									
3.7	Full Section Process Refinements								▲									10
3.8	Finalize Demonstration Procedures																▲	
3.9	Field Site Preparation																▲	75

11. Signature of Contractor's Project Manager and Date	12. Signature of Government Technical Representative and Date
--	---

U. S. ENERGY RESEARCH AND DEVELOPMENT ADMINISTRATION
MILESTONE PLAN AND MANAGEMENT REPORT

Page 41

1. Contract Identification DEVELOPMENT OF AUTOMATED WELDING PROCESS FOR FIELD FABRICATION OF THICK WALLED PRESSURE VESSELS		2. Reporting Period 6/29/80 through 9/28/80		3. Contract Number DE-AC05-78OR13511												
4. Contractor Name, address WESTINGHOUSE ELECTRIC CORPORATION NUCLEAR EQUIPMENT DIVISIONS P.O. BOX 19218 TAMPA, FLA. 33626		5. Contract Start Date 09-29-78		6. Contract Completion Date 09-28-81												
7. Identification Number	8. Reporting Category (e.g., contract line item or work breakdown structure element)	9. Fiscal Years and Months												10. Phase Code		
		FY 79				FY 80		FY 81								
		01	02	03	04	01	02	03	04	01	02	03	04			
3.10	Horizontal Position Welding - PHWT											△				
3.11	Vertical Position Welding - PHWT											△				
3.12	Non Destructive Evaluation											△				
3.13	Mechanical Testing - Demonstration Welds											△				
3.14	Weld Demonstration Report											△				
3.15	Quarterly Reports	▲	▲	▲	▲	▲	▲	▲	▲	△	△	△	△			
4.0	WELDING PROCESS PROCEDURE HANDBOOK															
4.1	Process Specification											△				
4.2	Operation Manual											△				

11. Contractor's Project Manager and Date _____
 12. Signature of Government Technical Representative and Date _____