

REPRODUCTION OF THIS REPORT AVAILABLE FREE
It has been reproduced from the best
available copy to insure the broadest
possible availability.

LBL--17685

DE84 013239

HEAVY ION UPGRADE OF THE BEVATRON LOCAL INJECTOR*

J. Staples, R. Gough, S. Abbott, R. Dwinell, J. Halliwell,
D. Howard, R. Richter, G. Stover, J. Tanabe and E. Zajec

Lawrence Berkeley Laboratory
University of California
Berkeley, California 94720

May 1984

Presented at the 1984 Linear Accelerator Conference,
Seeheim/Darmstadt, West Germany, May 7-11, 1984

* This work was sponsored by the Director, Office of Energy Research, Office of High Energy and Nuclear Physics, Nuclear Science Division, U.S. Department of Energy, under contract number DE-AC03-76SF00098.

DISCLAIMER

This report was prepared as an account of work sponsored by an agency of the United States Government. Neither the United States Government nor any agency thereof, nor any of their employees, makes any warranty, express or implied, or assumes any legal liability or responsibility for the accuracy, completeness, or usefulness of any information, apparatus, product, or process disclosed, or represents that its use would not infringe privately owned rights. Reference herein to any specific commercial product, process, or service by trade name, trademark, manufacturer, or otherwise does not necessarily constitute or imply its endorsement, recommendation, or favoring by the United States Government or any agency thereof. The views and opinions of authors expressed herein do not necessarily state or reflect those of the United States Government or any agency thereof.

HEAVY ION UPGRADE OF THE BEVATRON LOCAL INJECTOR*

J Staples, R Gough, S Abbott, R Dwinell, J Halliwell, D Howard, R Richter, G Stover, J Tanebe and E Zecce
Lawrence Berkeley Laboratory, Berkeley, California 94720, USA

Abstract

A new heavy ion injector system for the Bevatron, consisting of a PIG ion source, an RFQ linac, and two Alvarez linacs, is nearing completion. It will make available to the Bevatron a source of ions up to mass 40 independent of the SuperHILAC, enhancing the operational flexibility of the Bevalac complex. The RFQ accelerator, made operational in mid 1983, accelerates ions with $q/A \approx 0.14$ to 200 keV/n. The RFQ is followed by a new 200 MHz Alvarez linac operating in the 2B λ mode which further accelerates the ions to 800 keV/n. This linac is followed by a foil stripper and a portion of the old injector linac, rebuilt to accelerate beams with $q/A \approx 0.35$ to 5 MeV/n in the 2B λ mode. Details are given of the configuration, equipment modifications, and project status.

Introduction

The Bevatron has accelerated heavy ion beams since 1971, when deuteron, alpha and nitrogen beams were made available at energies from 28 to 2.1 GeV/n¹. These beams were provided by the 20 MeV proton injector, the "local injector", operating in the 2B λ mode, with the deuterons and alphas provided by a duoplasmatron and the nitrogen provided by a PIG ion source. Extracted intensities of 10^{11} deuterons, $5 \cdot 10^9$ alphas and $7 \cdot 10^5$ nitrogen ions per pulse were available.

In 1974, a transfer line linking the SuperHILAC to the Bevatron was completed, forming the Bevalac². With a vacuum in the low 10^{-7} Torr range, beams up to ⁵⁶Fe could be accelerated, and substantially higher intensities of the lighter ions. These light ion beams were used on a daily basis for the biomedical program and were generally provided by using the SuperHILAC as the injector, with the local injector as a lower intensity backup. However, the mixing of a light and a heavy ion beam causes certain difficulties, as the focussing quadrupoles in the SuperHILAC linacs are d.c., not pulsed, narrowing the range of ions that can be multiplexed through the tanks. By 1982, the vacuum in the Bevatron was improved to better than 10^{-10} Torr permitting relativistic acceleration of uranium and of partially stripped ions in the Bevalac³.

It is thus apparent that a new injector facility is needed at the Bevatron, independent of the SuperHILAC, that will provide a reliable source of light ions at high intensity primarily for use in the biomedical program, but also as an alternative to the SuperHILAC for some of the physics programs at the Bevatron.

New Local Injector System

The new local injector system consists of a sputter PIG ion source and a duoplasmatron, followed by an RFQ and two Alvarez linacs (a pre-stripper and a post-stripper). The design ion is silicon, which drives the parameter selection listed below, but the injector will work with useful intensity with ions as heavy as argon.

In this design, Si⁴⁺ is extracted from the PIG ion source and accelerated to 200 keV/n by a new RFQ linac operating at 200 MHz⁴. A new 200 MHz Alvarez prestripper linac operating in the 2B λ mode further accelerates the $q/A \approx 0.143$ ion to 800 keV/n, where it is stripped by a foil to the +10 charge state with a 30% efficiency. The ion with $q/A \approx 0.35$ is further accelerated to 5 MeV/n by the last 51 cells of the old local injector, which has had the first 24 cells removed. The beam is stripped once again, with a 50% efficiency and injected into the Bevatron.

The tank of the old Alvarez linac, with the first 24 cells removed, provides room to install part of the new Alvarez prestripper linac in its low energy end. The new prestripper cavity is longer than the section of the tank vacated by the old linac, so a 16 meter long extension is added. A 7 cm thick diaphragm is included between the two cavities which terminates the downstream end of the prestripper and the upstream end of the poststripper, and houses the foil stripper itself. The second stripper, at the end of the linac, has been used for all previous heavy ion operation and is already in place. Figure 1 shows the upgraded configuration.

Expected Performance

The beam intensity through the system is given in Table 1. The extracted and delivered intensity includes the known Bevatron capture, acceleration and extraction efficiency, and a 4 second cycle time to maximum guide field. Biomedical beams are frequently extracted at a lower guide field, reducing the cycle time by as much as a factor of two, raising the average particle flux over that listed below.

Table 1

Ion	carbon	neon	silicon	argon	
Charge state	- 2	+ 3	+ 4	- 6	
Ion source output	1400	670	135	80	ppA
LEBT output	980	469	95	55	ppA
RFQ output	784	375	76	45	ppA
Prestripper output	706	338	68	40	ppA
First stripper	353	149	27	3	ppA
Poststripper output	265	111	20	6	ppA
Second stripper	238	34	3	1	ppA
MEBT output	167	59	6	0.7	ppA
Extracted, delivered	$1 \cdot 10^{10}$	$3 \cdot 10^9$	$3 \cdot 10^8$	$4 \cdot 10^7$	p/sec

The PIG ion source has been under development since 1971. The intensities listed in Table 1 are based on proven ion source performance. The performance uncertainties of the rest of the linac chain are small, as the RFQ has already been operated, the stripper performance is well known, and the Alvarez linac acceptances are large compared to the RFQ.

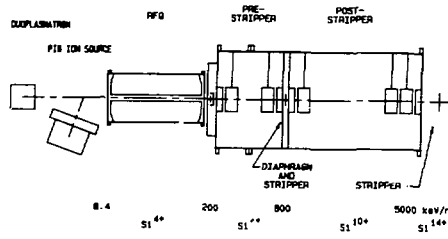

Fig. 1. Overall layout schematic showing the ion source, RFQ, and two Alvarez cavities. The poststripper consists of the last 51 cells of the original injector linac.

Details of Components

Ion Sources

The sputter PIG ion source used at the Bevatron for injection of ions through argon is similar to the type of PIG source used at the SuperHILAC Eve injector⁵. The water cooled tantalum extraction slit position is adjustable and is connected to the extractor electrode which may be pulsed as high as 30 kV. The source cathodes are titanium and at a 2% duty cycle may operate for a week or more without replacement.

The source for production of metallic ions uses the same basic geometry and includes a sputter electrode located opposite the extraction aperture. Neon is the primary support gas used with the silicon source and in both sources a pulsed quartz piezoelectric valve is used to inject the support gas.

A duoplasmatron ion source, injecting straight through the 70° PIG analyzing magnet will provide deuteron and alpha beams. Each ion source can be operated independently for testing purposes.

All ion source power supplies, A.C. distribution network, vacuum equipment, and the computer control system are contained in a four bay, rack mounted on insulators. The rack, transmission line, and the ion source housing can be raised by a DC power supply to 80 kilovolts above earth ground. All power supplies are referenced to rack ground, modular in construction, and easily removable for maintenance. A.C. power is delivered to the rack via a 21 KVA, 3 phase isolation transformer.

* This work was sponsored by the Director, Office of Energy Research, Office of High Energy and Nuclear Physics, Nuclear Science Division, U.S. Department of Energy, under contract number DE-AC03-76500098.

LEBT

The LEBT from the ion source to the RFQ is similar to the design used during the RFQ acceptance tests⁶. The Si^{+4} beam from the ion source is first accelerated across the 20 kV extractor gap, analyzed by 110° in the magnetic field of the source magnet, focussed by an einzel lens, and further accelerated by a 39 kV gap. The 8.4 keV/m beam is focussed by a pair of doublets through a 70° magnet to the final focussing quadrupole 4-plet 7 cm in front of the RFQ. The close spacing between the last focussing lens and the RFQ is dictated by the strong convergence required by the beam. The last vacuum valve is on the upstream side of the 4-plet, and a small Faraday cup with one central plate surrounded by a segmented annulus is inserted between the 4-plet and the RFQ.

RFQ Accelerator

The RFQ captures and accelerates a $q/A = 0.143$ beam from 8.4 to 200 keV/m at a frequency of 200 MHz. As space charge forces are not significant in this injector, a shortened sextant/buncher design has resulted in a structure 2.24 m long with 346 cells. The normalized transverse acceptance (100% contour) is 0.05° cm-mrad and the peak surface field at design gradient ($q/A = 0.143$) is 27 MV/m.

The RFQ, being the critical item in the linac chain, was designed, constructed and tested first before the old linac injector was disassembled. The results of the acceptance tests have already been published⁶, the RFQ meeting all our criteria. Immediately after finishing these tests in the summer of 1983, the 500 kV Cockcroft-Walton accelerator was removed to make way for the smaller 59 kV ion source equipment.

Alvarez Accelerator

The new Alvarez prestripper linac immediately follows the RFQ as shown in Figure 2, spaced by a 15.5 cm gap from the exit of the RFQ vane to the center of the gap in the first Alvarez cell causing the $\pm 15^\circ$ bunch to spread to $\pm 22^\circ$. The prestripper accelerates a $q/A \approx 0.143$ beam from 200 to 800 keV/m at 200 MHz. It is 3.53 m long, containing 38 cells. The drift tubes are all 14.5 cm in diameter, containing pulsed quadrupoles in a FFDD configuration, with the g/l increasing from 0.169 at the front end to 0.185 at the exit. The average axial field E_0 increases from 2.25 to 2.63 MV/m, for an average gap field of slightly over 13 MV/m in all the drift tube gaps. This field is high but quite a bit lower than the more than 15 MV/m field in the gaps of the old linac when operated as an injector in the 2BA mode for ions with $q/A = 0.33$.

The 17% tilt evers out the gap fields and increases the transverse acceptance of the linac, which is about 0.1° cm-mrad in both planes, normalized.

The prestripper is contained partly in the cavity previously occupied by the first 24 cells of the old linac and partly in a new 1.6 m long tank extension bolted onto the front end of the old linac. The drift tubes removed from the old linac were of double stem construction, each leaving two holes in the tank, azimuthally spaced by 90° . These holes were plugged and new holes were cut in the tank for the new double stem drift tubes, these holes rotated azimuthally by 22.5° from the old holes. This 22.5° rotation is carried on through the new tank addition, so all stems have the same orientation. The pulsed quadrupoles are oriented in the conventional sense.

The drift tube quadrupole magnets have wire wound coils and laminated poles and yokes. The poles are glued to the inside of the yoke ring while mounted in a precision assembly, fixture. The complete magnet assembly with the wire wound coils placed around each of the poles is then vacuum potted using a low shrinkage, high strength epoxy.

Each of the 14.5 cm diameter drift tube shells is made up of a body and a cap. The body is machined from solid OFHC copper rod, the cap from OFHC copper plate. The stems and stainless steel bore tubes are brazed to the drift tube bodies. Accurate stem and bore tube positioning along with minimal thermal distortion is accomplished by using special soldering fixtures. After the brazing is complete the quadrupole magnets are shrunk fit into the drift tube body and stem assemblies. The drift tube caps are electron beam welded to the bodies and bore tubes. There is negligible thermal distortion of the drift tube shells and no excessive heating of the magnets due to the low power input of the electron beam. Thus, no further machining is required after welding.

Cooling of the magnets and drift tube shells is accomplished by a 32°C water squirt tube inside one of the stems, providing effective cooling of the drift tube shells and magnets by thermal conduction through the copper drift tube bodies.

RF contact between the drift tube stems and the linac wall is made by compressing a washer fitted between each of the stems and tank wall. The washers have knife edges on both sides which cut into the wall and stems insuring good r.f. contact.

The prestripper linac uses 37 new drift tube quadrupoles divided into three groups, each having its own parameters and drive requirements. The basic current requirement for the largest groups was 42 amps max, flat to 1%, for 1 millisecond during the injected beam pulse.

The pulsed drift tube quadrupole power supplies consist of 40 water cooled bipolar transistor linear amplifiers. This apparatus was made available from a previous project, lowering the overall cost to below that of conventional pulsed capacitance discharge power supplies.

The prestripper and poststripper cavities are electrically separated from each other by a double walled diaphragm as shown in Figure 3. The walls are 7 cm apart, adding a drift 56% of the length of a 2BA cell. The transverse matching across the diaphragm is controlled by a small quadrupole in each half drift tube. A cassette containing several stripper foils and a wire position sensing grid for each plane is inserted through an airlock in the side of the tank to a position on axis between the two quadrupoles. The diaphragm consists of copper sheets mounted on an internal aluminum spider, clamped at their periphery to the outer tank wall with a copper hoop screwed to the tank wall every 4.1 cm. The half drift tubes at the ends of each cavity are axially moveable by ± 50 mils (± 0.13 cm) from outside the tank. Each cavity contains rotatable resonant loop tuners located every 64 cm along the tank.

Two new large holes were bored into the old linac tank for the stripper cassette airlock and for a new r.f. drive loop. The diaphragm straddles a pumping port, so safety pressure relief plugs were not included in the diaphragm design (as used in the diaphragms in the SuperHILAC). The extension tank contains two large pumping ports for the prestripper Alvarez.

The 1.6 meter long extension tank was rolled and welded from copper clad steel plate. Care was taken to remove all the copper cladding from areas which were welded to prevent copper induced weld cracking in the steel welds. The weld areas were then carefully fitted with copper strips which were welded in. Holes were drilled in the tank for 20 drift tubes, 3 r.f. coupling loops, 3 monitoring loops, and two pump ports. Copper plates with holes to provide adequate pumping were

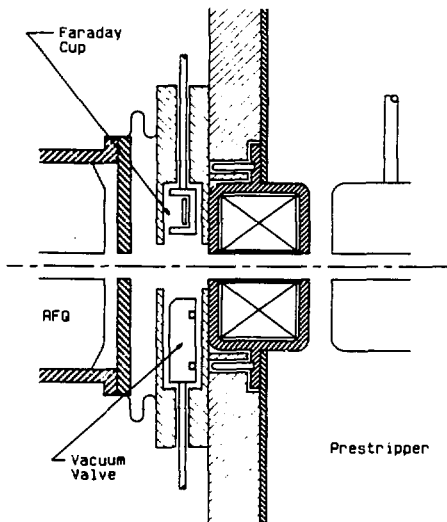

Fig. 2. RFQ-prestripper transition section schematic with vacuum valve, Faraday cup and first half drift tube. The end drift tube positioning device is not shown.

SL 80-171

fitted and welded to the large pump ports. Copper sleeves were fitted and welded to the coupling loop and monitoring ports

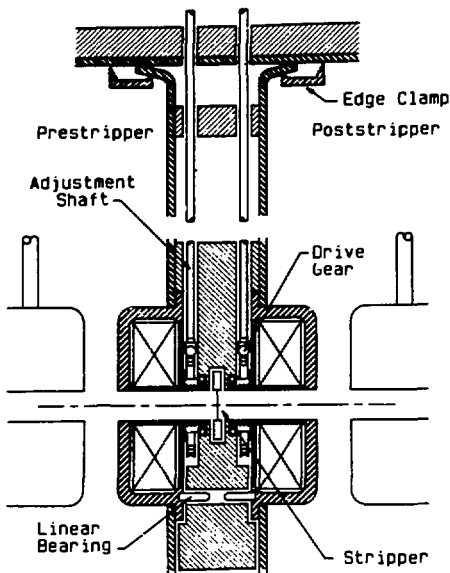

Fig. 3 Prestripper-poststripper transition schematic showing the two half drift tubes, quadrupoles, channel for insertion of stripper, and connection of diaphragm periphery to tank wall. The drive gear, turned by the adjustment shaft, moves the drift tube longitudinally

LBL 844-1370

The old Alvarez, used as an injector in the 28 kV mode since 1971, has accelerated ions with a q/A as low as 0.33 (C^{+4}). The transit time factor in the first group of 12 cells ranges from 0.31 to 0.46, requiring an average axial field of at least 3.5 MV/m at the beginning of the tank. The tilt introduced into the tank was about 9%, giving a field at the exit of the tank of 3.2 MV/m, larger than required beyond cell 24, the first cell of the third group, the groups differentiated by different bore diameters. This high accelerating gradient, has produced some damage to the faces of the first few drift tubes. The copper surface, almost out to the outer diameter, has been considerably roughened, and a substantial amount of copper dust from the drift tube faces was found on the bottom of the tank. The thickness of the drift tubes was originally adjusted by thick copper plating, which shows signs of lifting on one of the drift tubes. Very high gradient operation is indeed possible, but seems to take its toll with substantial surface damage.

The first two groups of drift tubes, 24 of them, with bore radii of 0.63 and 0.95 cm are removed from the old line. The transit time factors of the remaining drift tubes with bore radii of 1.27 and 1.59 cm are at least 0.38 in the 28 kV mode, allowing acceleration of $q/A \approx 357$ (Si^{+10}) with an average axial field of 2.8 MV/m and no tilt, less than the past operating gradient of over 3.2 MV/m at the end of the tank but more than the original design gradient of 2.0 MV/m. This part of the linac is far past the first few drift tubes that showed surface damage due to high gradient operation.

RF System

The original rf amplifier system consisted of two TH-515's, each driven by a 300 kW driver, feeding a coaxial distribution manifold connected to the old Alvarez with two drive loops. The new arrangement will consist of one 300 kW amplifier driving a TH-515, which drives two TH-515's, one for the prestripper, and one for the poststripper. The TH-515 has a gain of 10 db, and with sufficient drive can deliver 3 MW of power. The prestripper will require 0.6 MW and the

poststripper 2.2 MW at full gradient. The RFQ, requiring 160 kW, will be driven by the 300 kW driver made available by the reconfiguration. The entire rf system will be serviced from the longer poststripper tank. The phase and amplitude adjustments for the prestripper will be by trombones and rotatable loops at the 66 kW level, otherwise the prestripper rf will be locked to the poststripper.

Controls

The control system was designed to be compatible with the existing Bevalac control system while also providing some distributed pre-processing power. This compatibility will reduce the programming effort in the real time processors to one of merely adding a new device to a list of existing devices. Thus all of the existing software for closed-loop control, displays and storing and retrieving data may be used. The pre-processing will enhance the compatibility as well as off-loading some well defined and routine tasks from the existing system.

The existing control system consists of several ModComp 16 bit mini-computers acting as real time processors. These processors control all the Bevatron parameters and provide beam monitoring via high speed serial links. The data acquisition front end consists of in-house designed analog and digital hardware for controlling power supplies, acquiring beam data, etc. This front end hardware is linked to the real time processors via 1 MHz serial links.

It was at this front end level where we decided to provide some pre-processing power and to develop some newer data acquisition hardware. The analog front end consists of one signal conditioning amplifier and sample and hold per signal. This was necessary since most signals are of a pulsed 1 millisecond nature. The digital status and control are all passed through opto-isolated modules. These signals are then fed into a standard Multibus chassis for pre-processing and linking to the existing minicomputer control system. The pre-processing is performed by a standard 16 bit micro-processor CPU card. Also in the multibus chassis are several standard parallel I/O cards and an in-house designed serial link card to match the existing serial link protocol.

Project Status

The manufacture of all major elements of the project has been completed and final installation is in progress. Testing has been completed with the beam on the PIG ion source, PBT and RFQ. The remaining work is associated, for the most part, with the installation and commissioning of the Alvarez linacs and the duoplasmatron. First beam through the complete system for injection into the Bevatron is expected later this year.

This project could not have been carried out without the diligent work of R. Caylor, K. Kennedy, R. MacGill, S. Rovenpera and H. Schneider.

References

1. K. C. Crebbin et al., "First Phase of Heavy Ion Acceleration at the Bevatron," 1973 PAC, NS-20, No. 3, San Francisco, 1973, p. 178.
2. A. Ghiorso et al., "The Bevalac - An Economical Facility for Very Energetic Heavy Particle Research," 1973 PAC, NS-20, No. 3, San Francisco, 1973, p. 155.
3. R. T. Avery et al., "Performance of the New Cryogenic Vacuum System at the Bevatron," 1983 PAC, NS-30, No. 4, Santa Fe, 1983, p. 2895.
4. S. Abbott, D. Brodzik, R. Gough, D. Howard, H. Lancaster, R. MacGill, S. Rovenpera, H. Schneider, J. Staples and R. Yourd, "RFQ Development at LBL," Seventh Conference on Application of Accelerators, Denton, Texas, 1982.
5. H. Grunder, R. Richter, M. Tekawa, F. Zajec, "Pulsed Heavy Ion Source for the Bevatron," International Conference on Multiply Charged Heavy Ion Sources and Accelerating Systems, Gathinburg, 1971, p. 208.
6. J. Staples, R. Gough, H. Schneider, E. Zajec, "Initial Operation of the LBL Heavy Ion RFQ," Twelfth International Conference on High Energy Accelerators, FNAL, 1983.

This report was done with support from the Department of Energy. Any conclusions or opinions expressed in this report represent solely those of the author(s) and not necessarily those of The Regents of the University of California, the Lawrence Berkeley Laboratory or the Department of Energy.

Reference to a company or product name does not imply approval or recommendation of the product by the University of California or the U.S. Department of Energy to the exclusion of others that may be suitable.