

LA-UR- 98-942

HIGH INTENSITY PROTON LINAC ACTIVITIES AT LOS ALAMOS

CONF-9710122--

B. Rusnak, K. C. Chan, B. Campbell, B. Gentslinger, B. Haynes, F. Krawczyk, A. Shapiro, R. Bibeau, D. Montoya, B. Smith, R. Lujan, T. Hargenrader, D. Hammon, Los Alamos National Lab, Los Alamos, NM 87545, H. Safa, CEA Saclay

Abstract

High-current proton linear accelerators offer an attractive alternative for generating the intense neutron fluxes needed for transmutations technologies, tritium production and neutron science. To achieve the fluxes required for tritium production, a 100-mA, 1700-MeV cw proton accelerator is being designed that uses superconducting cavities for the high-energy portion of the linac, from 211 to 1700 MeV. The development work supporting the linac design effort is focused on three areas: superconducting cavity performance for medium-beta cavities at 700 MHz, high power rf coupler development, and cryomodule design. An overview of the progress in these three areas will be presented.

Introduction

In recent years, the application landscape for particle accelerators has been changing dramatically. Where large accelerators have traditionally been the tools of the trade for high-energy nuclear and particle physics, accelerator applications in the last decade have grown to include large-scale applications like synchrotron light sources and spallation neutron drivers. Accelerator-driven spallation sources have a number of potential applications which include neutron science, transmutation of nuclear reactor waste, sub-critical nuclear power generation, tritium production, and radiation-damage studies. While the generation of neutrons is the goal in each of these areas, specific applications require differing neutron energy, time, and fluence profiles from the spallation target.

Two application goals of significant interest at Los Alamos are the production of tritium and nuclear waste transmutation. Studies done at LANL that combine neutron production from high-Z targets, nominal accelerator parameters achievable today and the process requirements for these applications indicate that multi-megawatt proton accelerators with 100-mA beam current and final energies between approximately 1 and 2 GeV will provide the desired neutron fluxes in spallation targets [1]. Since these two applications are material-throughput processes, continuous-wave (cw) operation gives the highest overall efficiency for the operation of a plant.

Having shown that this class of accelerator is a feasible alternative to reactors for generating intense neutron fluxes, design optimizations on machines of this type have been carried out over the past three years. The goal of these optimizations is to increase the machine's reliability, operability and maintainability while reducing the operating and capital cost. This effort resulted in a machine design that applied superconducting rf technology to the high-energy portion of the linac (from 211 to 1700 MeV).

Work supported by the US Department of Energy

 MASTER

DISTRIBUTION OF THIS DOCUMENT IS UNLIMITED

DISCLAIMER

This report was prepared as an account of work sponsored by an agency of the United States Government. Neither the United States Government nor any agency thereof, nor any of their employees, makes any warranty, express or implied, or assumes any legal liability or responsibility for the accuracy, completeness, or usefulness of any information, apparatus, product, or process disclosed, or represents that its use would not infringe privately owned rights. Reference herein to any specific commercial product, process, or service by trade name, trademark, manufacturer, or otherwise does not necessarily constitute or imply its endorsement, recommendation, or favoring by the United States Government or any agency thereof. The views and opinions of authors expressed herein do not necessarily state or reflect those of the United States Government or any agency thereof.

DISCLAIMER

Portions of this document may be illegible in electronic image products. Images are produced from the best available original document.

Proton-Linac Design

The accelerator design proposed for the Accelerator Production of Tritium (APT) Project is a 100-mA, cw proton linac [2]. The beam would be bunched at 350 MHz with a Radio Frequency Quadrupole (RFQ), then accelerated to 211 MeV by a combination of Coupled Cavity Drift Tube Linac (CCDTL) and Coupled Cavity Linac (CCL) structures. At 211 MeV, the beam would enter into a superconducting linac. From 211 MeV to 471 MeV, the beam would be accelerated with 5-cell, 700-MHz elliptical superconducting cavities that have a reduced gap to better match the changing sub-relativistic velocities of the proton beam. The design beta for this section is 0.64. To maintain the required transverse focusing from the lattice, there are two 5-cell cavities per each cryomodule, which is between room-temperature quadrupole doublets. From 471 MeV to 1700 MeV, the cavity design beta goes to 0.82, and the lattice period increases to allow four 5-cell cavities per cryomodule, which is between the doublets. Fig. 1 shows a schematic layout of the linac design.

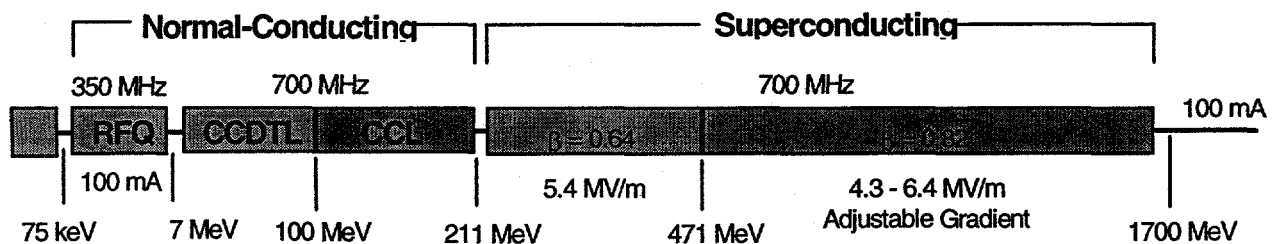

Fig. 1. Schematic layout of a cw proton linac showing the transition energies between various linac structures.

Since the velocity of the protons is changing as the beam goes through the linac, it is necessary to adjust the phase and gradient of the superconducting cavities along the length of the section to achieve efficient acceleration. This was one of the criteria that set the number of cells in each cavity to five. A certain amount of longitudinal phase mismatch was tolerated in the design to achieve the manufacturing simplicity that comes with only having two cryomodule designs in the linac. While this will lead to a slightly longer machine, it was felt the benefits in manufacturing and the smaller number of inventoried spare cryomodules to facilitate change outs were sufficiently attractive attributes of the integrated design to offset the increased length.

The other criteria that set the cell number was the amount of power that could be reliably delivered to the beam. It was felt that building a coupler that could handle 210-kW of cw power at 700 MHz was a reasonable goal. By putting two couplers per cavity, this allowed delivery of 420 kW into the beam while keeping peak electric fields below 18 MV/m.

An additional constraint on the machine design related to being able to do hands-on maintenance of the linac. With a high-energy 100-mA proton beam, losses greater than approximately 0.2 nA/m can cause significant activation to disallow hands-on maintenance. To minimize this possibility, the cavity and quadrupole apertures were chosen to be very large compared to the rms beam envelope. This was another advantage of using superconducting cavities in this application; the lower power

efficiency that comes from the decreased shunt impedance is much less important for superconducting cavities compared to copper structures.

Combining these constraints into a self-consistent linac design was done to evaluate the benefits of using a superconducting linac for the high-energy portion of this machine. In a comprehensive study of the applying rf superconductivity to this linac, the technical advantages were the large aperture, the ability to adjust gradient and phase along the linac which enabled varying the linac beam current and energy, and the ability to reconfigure the linac to compensate for failed modules which led to higher availability. In terms of cost, it was determined that using superconducting cavities in the high energy portion of the linac would reduce operating costs by as much as 20% over a conventional copper linac structure [3].

The parameter space for the design of such a linac is complex. There are many possible tradeoffs and compromises that need to be made between coupler power, gradient, number of cells, acceleration efficiency, beam current, aperture size, and focusing. The goal of the design effort was to select a combination of parameters that was conservative and would use values that were readily traceable to the present state of superconducting rf technology today to reduce cost and risk [4].

Technology Development and Demonstration

Rf Superconductivity has a mature application base in electron accelerators and heavy ion machines. Applying this to proton linacs raises some technical questions that cannot be directly addressed by this database. The technical issues are the performance of $\beta < 1$ elliptical niobium cavities and the effect of stray high-energy protons on the superconducting properties of a niobium cavity. Additional development work is also needed for the 210-kW power coupler, and for the cryomodule.

Medium- β Cavity Performance

Proton linacs in the 100- to 1000-MeV energy range need to effectively deal with the changing velocity of the proton beam in order to accelerate the beam efficiently. In a superconducting cavity, this is done by reducing the iris-to-iris spacing in a multicell structure. As this spacing is nominally $\beta\lambda/2$, elliptical cavities designed to work with $\beta < 1$ particles are termed "medium-beta cavities."

These structures represent a new operational regime for elliptical superconducting cavities which have traditionally been used for relativistic-electron acceleration, and hence have a β of effectively one. The primary technical concern of these reduced- β shapes is that they could multipactor across the narrowed gap and broadened flat wall of the cavity. Multipacting was responsible for limiting the performance of superconducting cavities in the early 70's before the "elliptical" cavity shape was developed and shown to provide a solution to the problem [5].

To address these concerns, four medium- β 700-MHz cavities were fabricated at Los Alamos; two at $\beta=0.48$ and two at $\beta=0.64$. Field tests were done on these cavities to determine if multipacting was present, and also to evaluate the field performance of the reduced- β shape. Fig. 2 shows representative power sweeps of both cavity shapes at both 2 and 4 K.

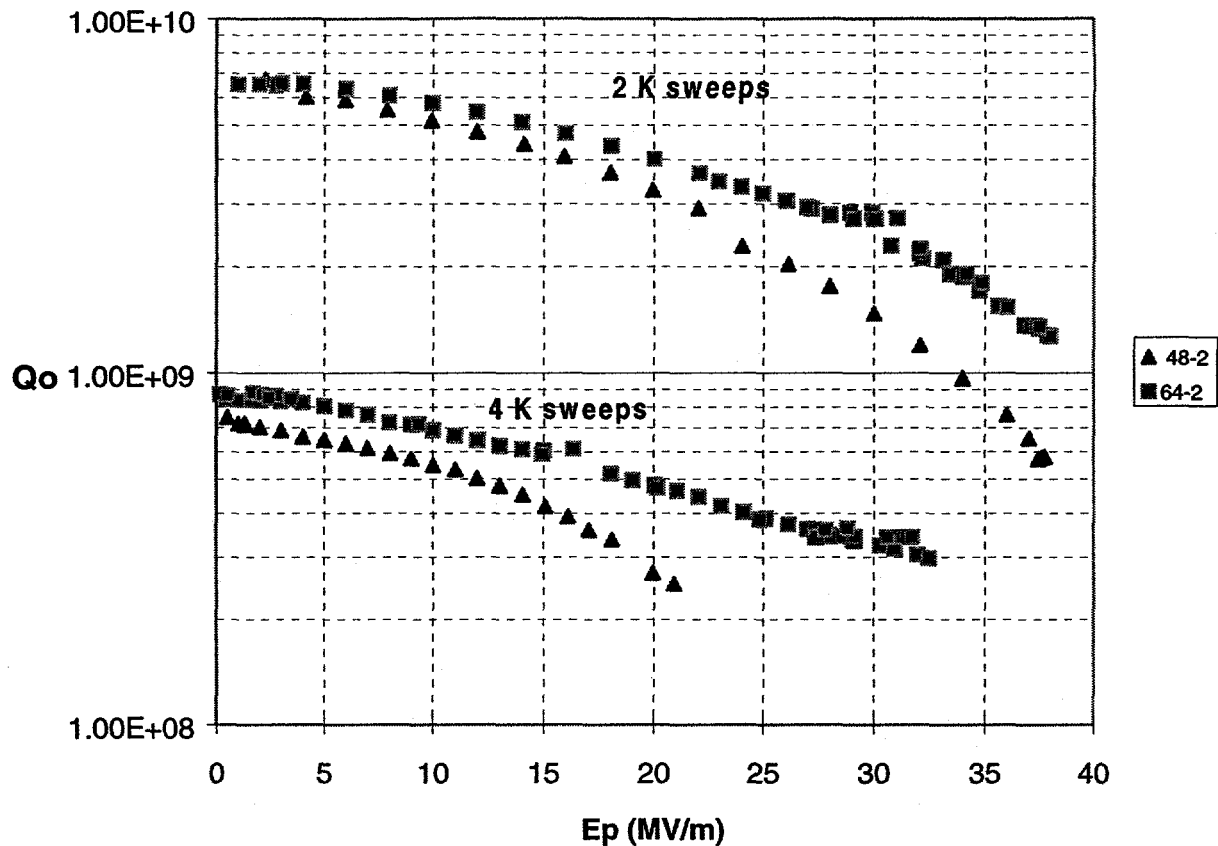

Fig. 2. Q_0 vs E_p curves for $\beta=0.48$ and 0.64 cavities at both 2 and 4 K. Neither cavity exhibited signs of multipacting, and field performance was acceptable.

As indicated in Fig. 2, and substantiated by 10 other tests, there was no indication of multipacting in the reduced β elliptical cavities. In addition, the field performance of the cavities was acceptable for the gradients needed for the project. Further information about the performance of these cavities and their run statistics are covered in another contribution to these proceedings [6].

Proton Radiation Effects Evaluation

To evaluate the effects of high-energy proton-induced radiation on the superconducting properties of a niobium cavity, a test was designed where two 3-GHz cavities were irradiated with up to 490 nA of 800 MeV protons at the LANSCE accelerator. The purpose of the test was to look for a manifestation of damage on the superconducting surface resistance of a cavity at cryogenic temperatures. Irradiating the cavity cold was done to insure any dislocation damage would remain frozen in, and would not be potentially repaired, as could be the case with a room temperature irradiation followed by a cold test.

The approach to the experiment was to irradiate two cavities. One cavity (cavity 1) was only measured at low power, to mitigate the possibility of rf conditioning changing the Q_0 . The other cavity (cavity 2) was swept in power to look at the high-field performance. For both cavities, the cavity Q_0 and field was measured at different stages between irradiations to evaluate cumulative damage effects. While the measurement data presented was obtained with the beam off, measurements were also taken with 490 nA passing through the cavity, and no deleterious effects were observed as a result of the primary beam or any secondary activity. After irradiation to 1.6×10^{16} p/cm², the cavities were warmed to 250 K, then re-cooled and remeasured. Fig. 3 shows a schematic layout of the test setup.

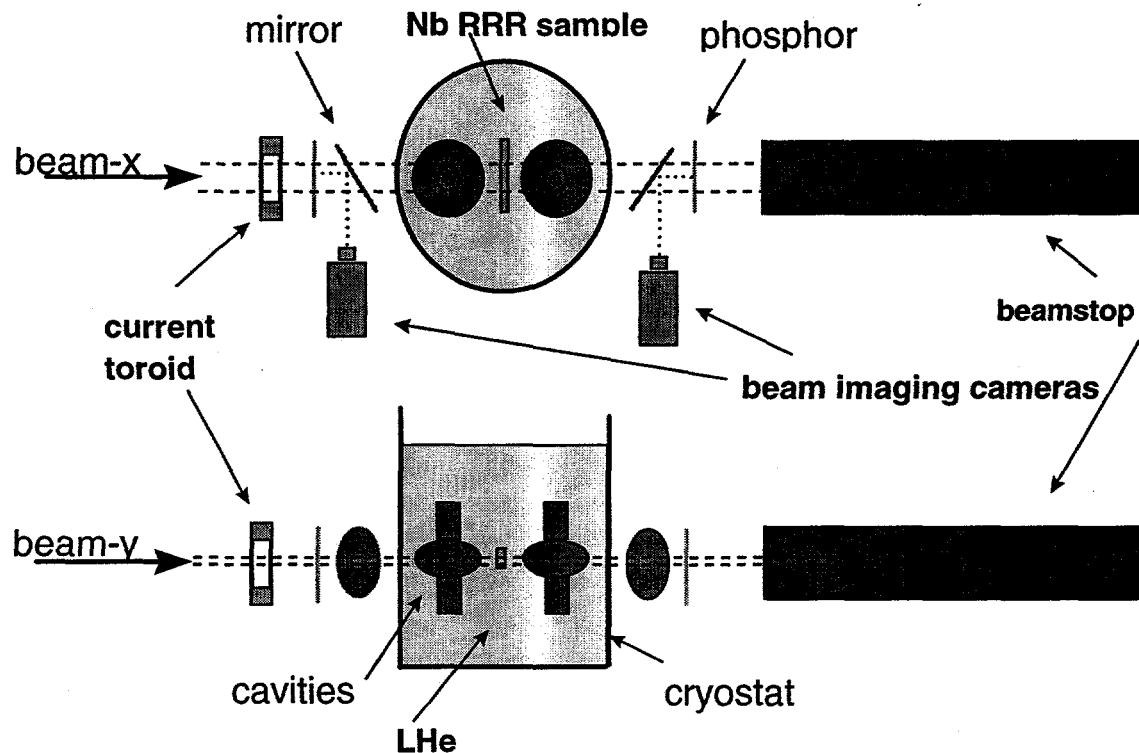

Fig. 3. Layout of the Proton Effects Experiment, showing the relative beam envelope to scale in the x and y planes. The 800 MeV proton beam passed through the entire assembly, including cavities, cryostat, and liquid helium. Approximately 10% of the beam was lost in transmission.

The goal of the test was to look for changes in the surface resistance (R_s) of the beam-affected zone. The cavities were run at 1.8-2.1 K to further increase sensitivity. Due to a residual magnetic field in the cryostat of less than 10 mG, the R_s at these temperatures was still not heavily dominated by the residual resistance (R_{res}).

To maximize the area and increase the sensitivity, the millimeter-size proton beam was expanded to 3.9 cm². With a H-field dominated cavity area of 161 cm², our maximum sensitivity to changes in R_s was estimated to be around 5%. Fig. 4 shows a plot of the low power Q_0 's for each cavity as a function of proton fluence. To a protons fluence of 1.6×10^{16} p/cm², no significant change was observed in the cavity Q_0 , indicating that there was no significant change in the local R_s due to radiation damage.

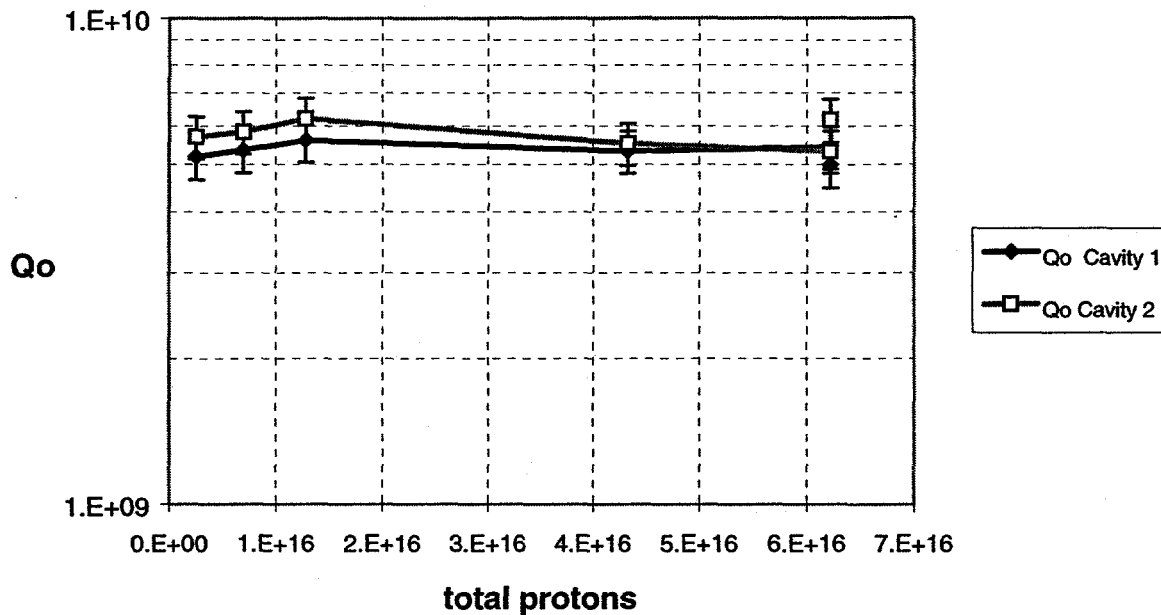

Fig. 4. Plot showing the low power Q_0 of both cavities as a function of fluence. No significant change was observed in the cavity Q_0 to a total proton irradiation of 6.2×10^{16} protons (fluence of 1.6×10^{16} p/cm²).

To evaluate the cavity field-handling capability as a function of irradiation, the second cavity (cavity 2) was swept in power between subsequent irradiations. The data from the power sweeps is shown in Fig. 5. The data is plotted as a histogram showing the maximum peak-electric field achieved before quench. As shown in the plot, the quench field decreased with an increase in total proton irradiation, which qualitatively agrees with other data that the RRR will decrease with increased proton radiation damage in the bulk material [7].

Fig. 5 also shows the response of the quench field to room-temperature annealing the cavity. The darker bar clearly shows an improvement in the quench field after the cavity was warmed to 250 K for approximately 1-2 hours. The improvement is attributed a "healing" of lattice damage due to radiation-induced dislocations having increased mobility at elevated temperatures compared to 2-4 K.

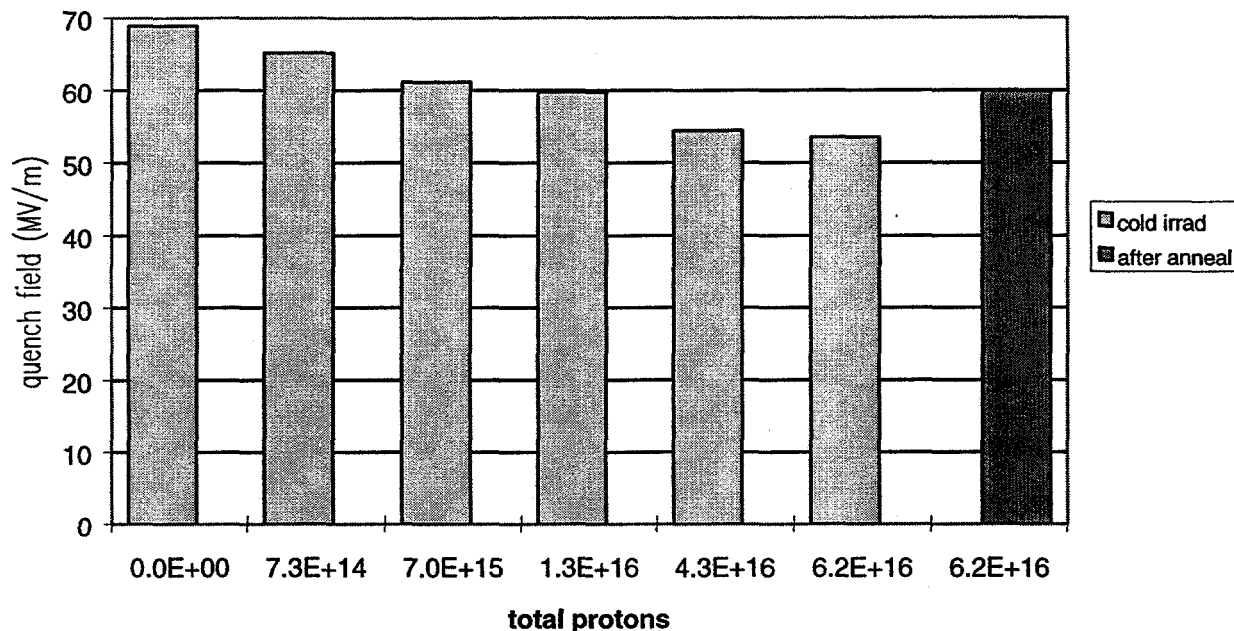

Fig. 5. Plot showing the maximum peak electric field achieved prior to quench related to the total number of protons irradiating the cavity. Note that the abscissa is not linear.

Power Coupler Development

The intensity of the proton beam in the APT accelerator necessitates the development of a high-power rf coupler. Even at modest accelerating gradients between 4.5 and 6 MV/m, the rf power in each cavity that is delivered to the 100 mA beam is 420 kW. As one of the primary design constraints on this linac application is high availability and reliability, we elected to focus our power coupler efforts on developing a 210-kW cw coupler, and then putting two couplers on each superconducting cavity. While this is a large number of couplers (approximately 800), we felt the modest amount of development needed to achieve a reliable 210-kW cw coupler was a reasonable trade off to the increased number of couplers needed. In addition, this approach was necessitated by the limited schedules of the ED&D program which supports the coupler development work.

The detailed coupler design is currently in development. One feature of the design is having two warm planar coaxial windows that are not in direct line of sight to the beam for isolating the cavity vacuum from the air in the waveguide. This window approach was selected since the world experience with high power couplers clearly shows that warm windows have been able to carry much higher cw rf power than cold windows. Having dual windows should decrease the extent of contamination in the event the air/vacuum window breaks or leaks, as the volume of air between the windows is limited. This translates into higher availability since fewer cavities would need to be taken "off line" in the event of a window failure.

Another feature of the design is in making the coupler adjustable over a limited range of external Q. Having an adjustable coupler is attractive, since optimal rf matching to the cavity allows more efficient operation of the accelerator and decreases the amount of standing wave power on the coupler and window. A schematic sketch of the window and coupler is shown in Fig. 6.

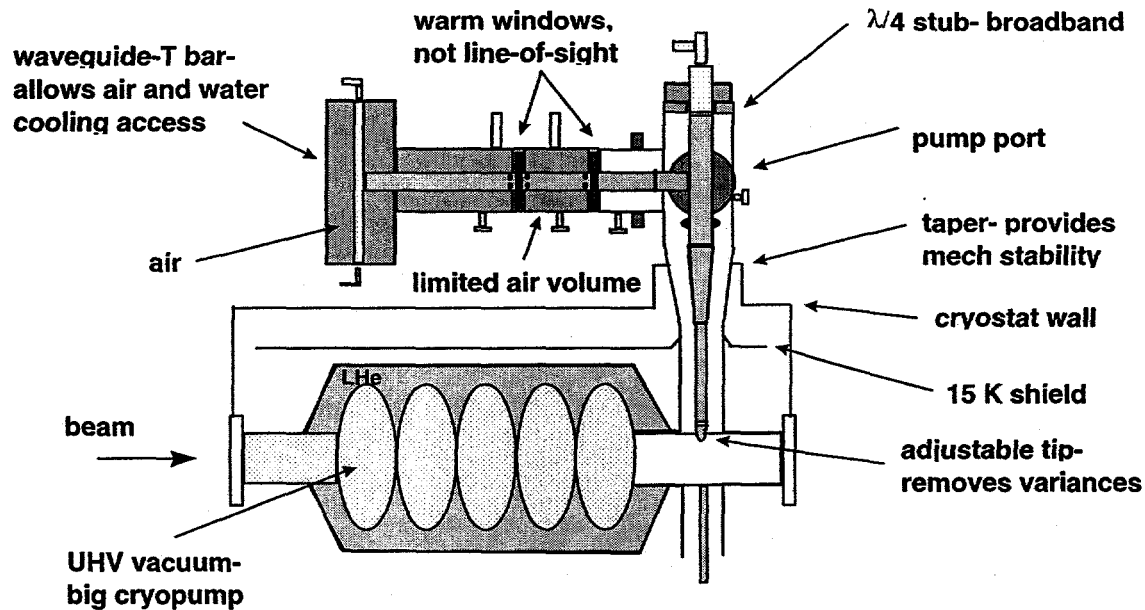

Fig. 6. Schematic diagram showing the design features being included in the 210-kW cw power coupler.

Modelling done using MAFIA indicates that the quarter-wave stub approach can be matched to a return loss greater than -35 dB, and with a bandwidth of 10 MHz the losses are no greater than -32 dB. To verify the modelling, low power rf measurements are also being carried out. A more detailed descriptions of the coupler design and modelling is available in another contribution in this proceedings [8].

Cryomodule Development

The cryomodule design effort for this linac is also underway for the $\beta=0.64$ and $\beta=0.82$ cryomodules. The $\beta=0.64$ cryomodule is made up of two 5-cell cavities, while the $\beta=0.82$ cryomodule encloses four. Fig. 7 shows a schematic representation of the cryomodule approaches for the different beta cavities.

As mentioned in the previous section, the power couplers for this accelerator are required to pass 420 kW to the beam, 210 kW through each coupler. Running at this power level puts additional constraints on the cryomodule approach in general and also changes how the thermal management on the cryomodule is optimized.

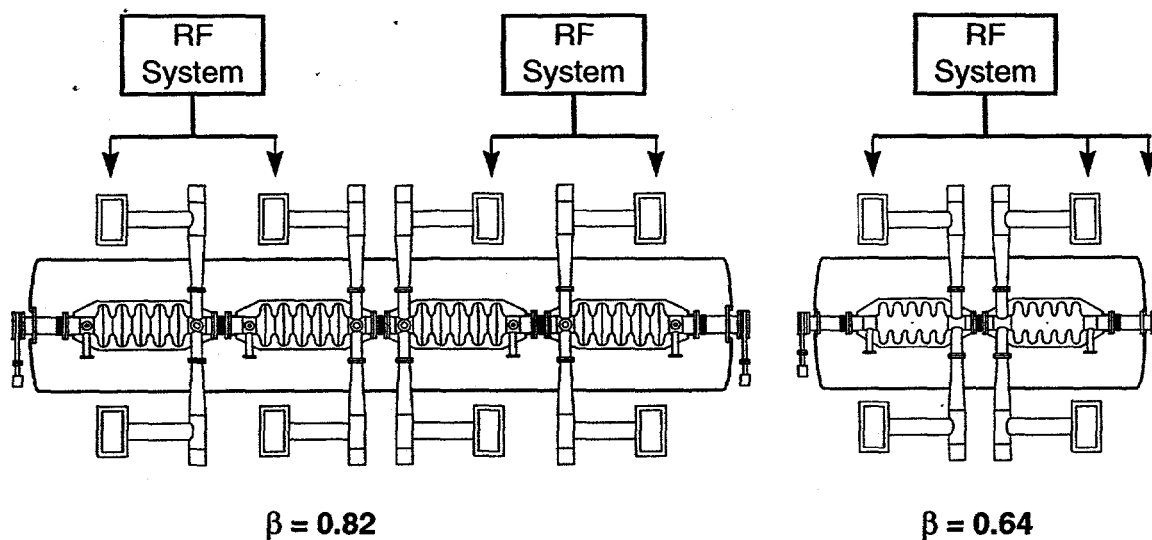

Fig. 7. Schematic representations of the $\beta=0.64$ and $\beta=0.82$ cryomodules.

Historically, the cryomodules designs for superconducting accelerators have fallen into two general categories: those with cold rf windows that are sealed in a clean room then assembled into the cryomodule as a unit (e.g., Jefferson Lab, TTF) and those with room-temperature rf windows that require the cavities be opened at some point to install the coupler into the partially (or fully) assembled cryomodule (e.g., CERN, KEK). The choice of window type (warm or cold) is driven primarily by how much average power needs to be delivered by the coupler. In applications where the average power is less than 5 to 10 kW, cold windows have proven to be a good approach since they greatly simplify the cryomodule design and assembly. In addition, cavities that are processed, cleaned, and assembled in the clean room and not reopened until they are on the beam line stand a greater chance of achieving higher gradients since the risk of contamination is believed to be lower.

For average power requirements on the coupler above 50 to 100 kW, the situation changes dramatically. Data from superconducting accelerators (KEK, CERN, DESY) clearly shows room-temperature windows are consistently used to reliably pass rf power at these levels. While test stand efforts in the past two years have seen windows and couplers go up to 500 to 800 kW average power [9,10], previous results indicate couplers and windows had difficulty running at 100 to 150 kW without failures. The limiting mechanisms in these assemblies were typically associated with the windows failing due to anomalous heating or arcing leading to heating and excessive stresses that cracked the ceramic, or from multipacting on the outer wall (for coaxial designs).

Given the difficulty of operating room-temperature windows at these powers suggests that achieving similar results with a cold window would be significantly more challenging, since cold windows require vacuum on both sides, and cold windows need to handle stresses not only from rf and electron heating, but also from contraction in cooling down to cryogenic conditions. Given these considerations, we elected to go with warm window for our couplers.

In choosing warm windows for this project, the resultant constraints on the cryomodule are apparent: either risk exposing the cavity to contamination by opening the cavities more than once, or assemble a large, complex assembly in the clean room. In both these cases, the main concern is

that contamination of the cavity may affect field performance. Fortunately for this application, the maximum expected peak surface electric field is 18 MV/m, so the contamination control constraints are not as stringent as they are for TTF at 50 MV/m, for example.

The difficulty is in quantifying which approach has a higher risk of contamination. Exposing the cavity by putting on the windows or couplers later necessitates taking special precautions in opening the coupler port late in the assembly stage. Assembling the cryomodule in a clean room to a significant level overly constrains the cryomodule thermal design and is no guarantee of the assembly being clean. The statistical nature of evaluating the impact of each of these approaches makes the task of choosing between them formidable.

The approach we elected at this time is to do enough of the cavity, coupler, window, and cryomodule assembly in a clean room to seal the cavities once, then build up the rest of the cryomodule outside the clean room. The major disadvantage in this is the thermal efficiency of the cryomodule design, as well as the assembly ease of the cryomodule may be compromised. A more detailed description of the cryomodule design work being done is available in another contribution in this proceedings [11].

Summary

Over the past two years, significant work has been done in the engineering development and demonstration of superconducting technology as it applies to intense proton linacs. Technological work has focused primarily in the areas of medium beta cavity performance, power coupler development, and the effects of proton radiation on the superconducting properties of niobium cavities. In moving toward an accelerator, design efforts are focussing on optimizing two different cryomodules corresponding to the two cavity beta types required.

To date, we have demonstrated that medium-beta-elliptical-cavity shapes down to $\beta=0.48$ show no evidence of deleterious multipacting at 700 MHz to field levels greater than twice the peak operating fields expected, and exhibit field and Q_0 performance similar to $\beta\approx 1$ cavities, thus addressing technical concerns about using these cavities for a proton linac that requires graded- β cavities.

In testing the resilience of niobium cavities to proton radiation, we have shown that the superconducting-cavity Q_0 appears to be virtually unaffected by proton radiation damage to 1.6×10^{16} p/cm², which is over a factor of 3 higher than the expected 40-year beam loss for the accelerator of 5×10^{15} p/cm². A drop in the cavity quench field of approximately 24% was observed, which did partially recover by warming the cavity to 250 K. This drop was attributed to the change in the RRR locally in the radiation-affected zone, which was experimentally determined elsewhere. But, since the required rf magnetic field levels needed for this application are approximately a factor of two below the expected quench field level for the test cavity, a change of the quench level of 10-20% is not a concern.

These two results give confidence in applying rf superconductivity to intense-beam proton linac applications. The other major component that needs demonstration is the high power rf coupler, which is the focus of significant development efforts not only at Los Alamos, but in the superconducting-accelerator community as a whole.

These results contribute to a growing technology base that supports applying superconducting rf structures to intense proton linac applications for spallation-neutron sources. These sources point in a new application direction for accelerator technology in general. Superconducting rf technology enables the design of many desirable features in such machines (operating efficiency, large apertures, operation flexibility) that makes it an attractive design option.

Acknowledgment

The authors would like thank all those who helped fabricate the medium beta cavities that were tested. The efforts made in forming, brazing, welding, machining, and chemical polishing were greatly appreciated.

References

- [1] G. P. Lawrence, T. P. Wangler, "Integrated Normal-conducting/Superconducting High-Power Proton Linac for the APT Project," Proceedings of the 1997 Particle Accelerator Conference, Vancouver, British Columbia, Canada, May 12-16, 1997, to be published.
- [2] "Conceptual Design Report", Los Alamos National Lab Report, LA-UR-97-1329, April 15, 1997.
- [3] K. C. D. Chan (ed), "A Feasibility Study of the APT Superconducting Linac, 1995," Los Alamos National Lab Report, LA-UR-95-4045, April, 1996.
- [4] G. P. Lawrence, T. P. Wangler, "Integrated Normal-conducting/Superconducting High-Power Proton Linac for the APT Project," Proceedings of the 1997 Particle Accelerator Conference, Vancouver, British Columbia, Canada, May 12-16, 1997, to be published.
- [5] U. Klein, D. Proch, "Multipacting in Superconducting RF Structures," Proceedings of the Conference on Future Possibilities for Electron Accelerators, Charlottesville, VA, 1979.
- [6] W. B. Haynes, et. al., "Medium-Beta Superconducting Cavity Tests at Los Alamos National Lab for High-Current, Proton Accelerators," this proceedings.
- [7] C. L. Snead, et. al., "Resistivity Changes in Superconducting-Cavity-Grade Niobium Following High-Energy-Proton Irradiation," Journal of Nuclear Materials, to be published.
- [8] F. Krawczyk, et. al., "Power Coupler Design for the APT Linear Accelerator," this proceedings.
- [9] S. Noguchi, private communication.
- [10] H. Kinderman, private communication.
- [11] B. Campbell, et. al., "Design Status of the Cryomodules for the APT Linac," this proceedings.

Publication External Mailing List
for RFSC publications
vers: 5/19/97

Dr. Daniel Boussard
CERN
AT Division
CH-1211 Geneve 23
Switzerland

Dr. Jean Delayen
Thomas Jefferson National Accelerator Facility
12000 Jefferson Ave.
Newport News, VA 23606

Dr. Peter Kneisel
Thomas Jefferson National Accelerator Facility
SRF Division
12000 Jefferson Ave.
Newport News, VA 23606

Dr. Motoharu Mizumoto
Department of Reactor Engineering
Japan Atomic Energy Research Institute
Tokai-mura, Naka-gun
Ibaraki-ken
Japan

Dr. Shuichi Noguchi
KEK High Energy Physics
Accelerator Department
1-1 Oho, Tsukuba-shi
Ibaraki-ken, 305
Japan

Dr. Hasan Padamsee
Newman Laboratory
Cornell University
Ithaca, NY 14853-5001
USA

Prof. Helmut Piel
Universitaet Wuppertal
FB 8, Physik
Gausstrasse 20
42097 Wuppertal 1
Germany

Dr. Dieter Proch
DESY
MHF-SL
Notkestrasse 85
D-22603 Hamburg
Germany

Dr. Claus Rode
Thomas Jefferson National Accelerator Facility
MS 12A2
12000 Jefferson Ave.
Newport News, VA 23606

Dr. Kenji Saito
KEK High Energy Physics
Accelerator Department
1-1 Oho, Tsukuba-shi
Ibaraki-ken, 305
Japan

Dr. Joachim Tuckmantel
CERN
AT/RF Division
CH-1211 Geneve 23
Switzerland

Dr. Yoshishige Yamazaki
KEK High Energy Physics
Accelerator Department
1-1 Oho, Tsukuba-shi
Ibaraki-ken, 305
Japan

on sabbatical @ LANL 5/97-5/98

Dr. Henri Safa
CE Saclay
DAPNIA/SEA
Orme des Merisiers
Bt 701
91191 GIF-SUR-Yvette Cedex
France