

PWR FLECHT SEASET 161-Rod Bundle  
Flow Blockage Task  
Task Plan Report

---

NP-1458  
Research Project 959-1  
FLECHT SEASET Program Report No. 6  
NUREG/CR-1370  
WCAP-9692

Interim Report, January 1981  
Work Completed, July 1980

Prepared by

WESTINGHOUSE ELECTRIC CORPORATION  
Nuclear Energy Systems  
P.O. Box 355  
Pittsburgh, Pennsylvania 15230

Principal Investigators

L. E. Hochreiter  
N. Lee  
H. W. Massie, Jr.  
M. J. Loftus  
M. M. Valkovic

Prepared for

United States Nuclear Regulatory Commission  
Washington, D.C. 20555

Program Management Representative  
L. H. Sullivan

Westinghouse Electric Corporation

Program Management Representative  
L. Chajson

Electric Power Research Institute  
3412 Hillview Avenue  
Palo Alto, California 94304

EPRI Project Manager  
Bill K. H. Sun

Water Reactor Technology Program  
Nuclear Power Division

DISTRIBUTION OF THIS DOCUMENT IS UNLIMITED

JHS

## **DISCLAIMER**

**This report was prepared as an account of work sponsored by an agency of the United States Government. Neither the United States Government nor any agency thereof, nor any of their employees, makes any warranty, express or implied, or assumes any legal liability or responsibility for the accuracy, completeness, or usefulness of any information, apparatus, product, or process disclosed, or represents that its use would not infringe privately owned rights. Reference herein to any specific commercial product, process, or service by trade name, trademark, manufacturer, or otherwise does not necessarily constitute or imply its endorsement, recommendation, or favoring by the United States Government or any agency thereof. The views and opinions of authors expressed herein do not necessarily state or reflect those of the United States Government or any agency thereof.**

---

## **DISCLAIMER**

**Portions of this document may be illegible in electronic image products. Images are produced from the best available original document.**

#### ORDERING INFORMATION

Requests for copies of this report should be directed to Research Reports Center (RRC), Box 50490, Palo Alto, CA 94303, (415) 965-4081. There is no charge for reports requested by EPRI member utilities and affiliates, contributing nonmembers, U.S. utility associations, U.S. government agencies (federal, state, and local), media, and foreign organizations with which EPRI has an information exchange agreement. On request, RRC will send a catalog of EPRI reports.

EPRI authorizes the reproduction and distribution of all or any portion of this report and the preparation of any derivative work based on this report, in each case on the condition that any such reproduction, distribution, and preparation shall acknowledge this report and EPRI as the source.

#### NOTICE

This report was prepared by the organization(s) named below as an account of work sponsored by the Electric Power Research Institute, Inc. (EPRI). Neither EPRI, members of EPRI, the organization(s) named below, nor any person acting on their behalf: (a) makes any warranty or representation, express or implied, with respect to the accuracy, completeness, or usefulness of the information contained in this report, or that the use of any information, apparatus, method, or process disclosed in this report may not infringe privately owned rights; or (b) assumes any liabilities with respect to the use of, or for damages resulting from the use of, any information, apparatus, method, or process disclosed in this report.

Prepared by  
Westinghouse Electric Corporation  
Pittsburgh, Pennsylvania

---

## EPRI PERSPECTIVE

### PROJECT DESCRIPTION

A major consideration in the design of engineered safety systems and licensing of pressurized water reactors (PWRs) is that there is sufficient heat transfer to cool the reactor core in the event of a loss-of-coolant accident (LOCA) or for long-term decay heat removal. Areas of technical concerns include reflooding (large-break LOCA), core uncover (small-break LOCA), and natural circulation (long-term cooling). A program called FLECHT SEASET (Full-Length Emergency Core Cooling Heat Transfer--Separate-Effects Tests And System-Effects Tests) is underway to address these concerns. It is a multifacility five-year test and analysis program. The program is jointly managed and funded by the U.S. Nuclear Regulatory Commission (NRC), Electric Power Research Institute (EPRI), and Westinghouse Electric Corporation (W). This work, under RP959-1, is closely coordinated as appropriate with major national and international research programs in the heat transfer areas of natural circulation, reflooding, and core uncover.

### PROJECT OBJECTIVE

The overall objective of this program is to provide experimental heat transfer and two-phase flow data in simulated PWR geometries for postulated conditions of reflooding, core boil-off, and natural circulation. The test parameters will cover a spectrum of conditions that encompass both the best-estimate and current licensing calculations. The test bundle simulates a full-length portion of PWR cores with fuel rod geometry typified by a Westinghouse 17 x 17 assembly design.

The program consists of two major subprograms, each with experimentation and analysis efforts: (1) the flow blockage subprogram to address safety and licensing requirements for steam cooling and the flow blockage effects and (2) the system effects subprogram to examine system and

bundle reflood response for a postulated LOCA. Both subprograms have flexibility to address small-break core uncover and natural circulation phenomena.

#### PROJECT RESULTS

Accomplishments to date are documented in the FLECHT SEASET Program NRC/EPRI/W Report No. 1 (Program Plan, December 1977); No. 2 (Steam Generator Separate-Effects Task Plan, March 1978); No. 3 (Unblocked Bundle Reflood Task Plan, March 1978); No. 4 (Steam Generator Separate-Effects Task Data Report, January 1980); and No. 5 (21-Rod Bundle Flow Blockage Task Plan Report, EPRI Interim Report NP-1382, October 1980).

This report documents the test and analysis plan to study the effect of flow channel blockage on reflooding heat transfer by using a 161-rod bundle test facility. The report should be useful to those who are interested in model development and computer code qualification in the area of reflooding heat transfer and steam cooling.

Bill K. H. Sun, Program Manager  
Nuclear Safety and Analysis Department  
FLECHT SEASET Program, EPRI Management Representative

## ABSTRACT

This report presents a descriptive plan of tests for the 161-Rod Bundle Flow Blockage Task of the Full-Length Emergency Cooling Heat Transfer Separate Effects and Systems Effects Test Program (FLECHT SEASET). This task will consist of forced and gravity reflooding tests utilizing electrical heater rods to simulate PWR nuclear core fuel rod arrays. All tests will be performed with a cosine axial power profile. These tests will be used to determine effects of flow blockage configurations on reflooding behavior and to aid in assessment/ development of computational models in predicting reflooding behavior of flow blockage configurations.



## ACKNOWLEDGMENTS

The work of the following Westinghouse Nuclear Energy Systems contributors, and the efforts of those individuals who formulated the blockage strategy contained herein is hereby acknowledged:

### PWR PROJECTS

H. J. Fix  
L. Chajson

### SAFEGUARDS DEVELOPMENT

R. P. Vijuk  
E. R. Rosal  
K. Beatty  
D. H. Dixon  
D. P. Kitzmiller

### THERMAL HYDRAULIC METHODS

J. E. Olhoeft

### FACILITIES ENGINEERING

L. R. Katz  
C. E. Conway  
B. R. Sinwell

### TEST OPERATIONS

C. E. Fuchs  
P. F. Orangio  
F. L. Lilly  
A. C. Toth

### FOREST HILLS DRAFTING

P. Brumbaugh  
J. Gaynord

### NUCLEAR FUEL DIVISION

D. L. Burman  
A. H. Wenzel  
T. K. Engel  
E. A. Dzenis

The work of the following members of the Program Management Group, their colleagues, and their consultants is hereby acknowledged:

EPRI - K. H. Sun, R. B. Duffey  
NRC-RSR - E. Davidson, L. B. Thompson, M. L. Picklesimer  
NRC-NRR - W. Hodges, D. A. Powers  
EG&G - G. Wilson  
NUS Corp. - D. A. Prelewicz



## TABLE OF CONTENTS

Section	Title	Page
1	SUMMARY	1-1
2	BACKGROUND	2-1
3	TASK OBJECTIVES	3-1
4	BLOCKAGE SHAPES AND TEST CONFIGURATIONS	4-1
4-1.	General	4-1
4-2.	Blockage Shapes	4-2
4-3.	Blockage Configurations	4-3
4-4.	Test Blockage Configurations	4-3
4-5.	Noncoplanar Blockage Distribution	4-6
4-6.	Partially Blocked Bundle	4-9
5	INITIAL CONDITIONS AND RANGE OF CONDITIONS	5-1
6	TEST FACILITY DESCRIPTION	6-1
6-1.	Facility Design and Layout	6-1
6-2.	Facility Component Description	6-5
6-3.	Test Section	6-5
6-4.	Test Bundle	6-6
6-5.	Carryover Vessel	6-6
6-6.	Entrainment Separator	6-6
6-7.	Exhaust Line Piping and Components	6-15
6-8.	Coolant Injection System	6-15
6-9.	Downcomer and Crossover Leg	6-17
6-10.	Heatup Boiler	6-17
6-11.	Facility Operation	6-18

## TABLE OF CONTENTS (cont)

Section	Title	Page
7	TEST FACILITY INSTRUMENTATION	7-1
7-1.	General	7-1
7-2.	Bundle Instrumentation	7-2
7-3.	Heater Rod Thermocouples	7-2
7-4.	Thimble Instrumentation	7-10
7-5.	Steam Probe Instrumentation	7-10
7-6.	Differential Pressure Measurements	7-14
7-7.	Power Measurements	7-14
7-8.	Plenum and Housing Instrumentation	7-15
7-9.	Upper Plenum	7-15
7-10.	Lower Plenum	7-15
7-11.	Housing	7-15
7-12.	Loop Instrumentation	7-17
7-13.	Data Acquisition and Processing System	7-23
7-14.	Computer Data Acquisition System	7-23
7-15.	Fluke Data Logger	7-28
7-16.	Multiple Pen Strip Chart Recorders	7-28
7-17.	Data Validation Criteria and Procedures	7-28
8	TEST MATRIX	8-1
8-1.	Introduction	8-1
8-2.	Shakedown Test Matrix	8-1
8-3.	Thermocouple Wiring Connection Checks	8-1
8-4.	Forced Reflood Configuration Testing	8-1
8-5.	Heater Rod Power Connection Check	8-2
8-6.	Instrumented Heater Rod Radial Location and Corresponding Thermocouple Checks	8-2

TABLE OF CONTENTS (cont)

Section	Title	Page
8-7.	Heater Rod, Thimble, and Steam Probe Axial Location Checks	8-2
8-8.	Test Section Differential Pressure Cell Axial Locations, Steam Separator Collection Tank and Carryover Tank Volume, and Level Transmitter Checks	8-2
8-9.	Pressure Control Valve Operation, Exhaust Orifice Plate Flow, and Differential Pressure Cell Zero Shift Checks	8-3
8-10.	Turbine Flowmeter Calibration and Flow Control Valve Operation Checks	8-3
8-11.	Carryover Tank, Steam Separator Tank, and Connecting Piping Heatup Checks	8-3
8-12.	Motion Picture Check	8-4
8-13.	Low-Power and Low-Temperature Test, Forced Reflood Configuration	8-4
8-14.	Steam Probe Operation Check	8-4
8-15.	Gravity Reflood Configuration Testing	8-5
8-16.	High-Range Turbine Flowmeter Flow Checks	8-5
8-17.	Bidirectional Turbo-Probe Flow Checks	8-5
8-18.	Low-Power and Low-Temperature Test, Gravity Reflood Configuration	8-5
8-19.	Test Matrix	8-5
8-20.	Constant Flooding Rate	8-6
8-21.	Pressure Effects	8-6
8-22.	Coolant Subcooling Effects	8-10
8-23.	Low Initial Clad Temperature	8-10
8-24.	Repeat Tests	8-10
8-25.	Variable Flooding Rate	8-10
8-26.	Gravity Reflood	8-11

TABLE OF CONTENTS (cont)

Section	Title	Page
9	DATA REDUCTION, ANALYSIS, AND EVALUATION PLANS	9-1
	9-1. Data Reduction	9-1
	9-2. Data Analysis and Evaluation	9-1
	9-3. Mechanistic Data Analysis	9-15
	9-4. Statistical Data Evaluation	9-16
10	TASK SCHEDULE	10-1
Appendix A	WORK SCOPE	A-1
Appendix B	FACILITY DRAWINGS	B-1
Appendix C	INSTRUMENTATION PLAN	C-1
Appendix D	BLOCKED BUNDLE TEST RUN SPECIFICATION AND VALIDATION SHEET	D-1
Appendix E	DATA REDUCTION AND ANALYSIS COMPUTER PROGRAMS	E-1

## LIST OF ILLUSTRATIONS

Figure	Title	Page
4-1	Blockage Sleeve for Beta Phase Swelling	4-4
4-2	Shape of Nonconcentric Sleeve	4-5
4-3	Bundle and Addresses of Subchannels Showing Line of Symmetry	4-10
4-4	Partial Blockage-Bypass Cases	4-12
4-5	Partial Blockage Case 1	4-13
4-6	Partial Blockage Case 2	4-14
4-7	Partial Blockage Case 3	4-16
4-8	Blockage Sleeve Distribution Used for COBRA Calculation (Case 3)	4-17
4-9	Blockage Sleeve Distribution Used for COBRA Calculation (Case 2)	4-18
4-10	Average Blockage Distribution of 21-Rod Cluster (Concentric Sleeve With 32.6% Strain)	4-19
4-11	Flow Rates in Channel 50	4-20
4-12	Flow Rates in Channel 51	4-21
4-13	Flow Rates in Channel 63	4-22
5-1	Cosine Axial Power Profile	5-6
6-1	Forced and Gravity Reflood Configuration Flow Diagram	6-3
6-2	FLECHT SEASET 161-Rod Blocked Bundle Test Section Assembly	6-7
6-3	FLECHT SEASET 161-Rod Blocked Bundle Low Mass Housing	6-9
6-4	FLECHT SEASET 161-Rod Blocked Bundle Cross Section	6-11
6-5	FLECHT SEASET Heater Rod Design	6-13
6-6	FLECHT SEASET Upper Plenum Baffle	6-16
7-1	FLECHT SEASET Computer Hardware Interface	7-3
7-2	Instrumented Heater Rod Locations	7-5
7-3	Instrumented Heater Rod Locations With Respect to Blockage Islands	7-6
7-4	Projected Instrumented Heater Rod Locations	7-9

## LIST OF ILLUSTRATIONS (cont)

Figure	Title	Page
7-5	Steam Probe and Thimble Wall Thermocouple Locations (161-Rod Bundle Task)	7-11
7-6	Steam Probe Schematic Diagram	7-12
7-7	Self-Aspirating Subchannel Steam Probe	7-13
7-8	Upper and Lower Plenum Thermocouple Locations (161-Rod Bundle Task)	7-16
7-9	161-Rod Blocked Bundle Task Loop Instrumentation	7-19
7-10	Exhaust Line Steam Probe (161-Rod Bundle Task)	7-21
8-1	Test-Simulated Boundaries of Predicted Upper Plenum Pressures During Reflood	8-7
8-2	Predicted Flooding Rate During Core Reflood of a Westinghouse PWR Dry Containment Plant	8-12
8-3	Predicted Flooding Rate During Core Reflood of a Westinghouse Ice Condenser Plant	8-13
8-4	Variable Stepped Flow Simulation of Predicted Core Reflood of a Westinghouse PWR Dry Containment Plant (Two Steps)	8-14
9-1	Flow Logic of Computer Codes	9-2
9-2	FLECHT SEASET Data Reduction Flow Chart	9-3
9-3	Sample Distribution Plots	9-19
9-4	Sample Frequency Distribution Plots at Different Elevations for a Given Time	9-20
10-1	Task Schedule for FLECHT SEASET 161-Rod Bundle Heat Transfer	10-3

## LIST OF TABLES

Table	Title	Page
2-1	Comparison of PWR Vendors' Fuel Rod Geometries (Old and New)	2-4
3-1	Blockage Configurations To Be Tested in 161-Rod Bundle	3-2
4-1	Comparisons of Partial Blockage - Bypass Configurations	4-23
5-1	Basic Data To Be Obtained for 161-Rod Bundle Flow Blockage Task	5-2
5-2	Reference and Range of Test Conditions for 161-Rod Bundle Flow Blockage Task	5-4
6-1	Thermophysical Properties of Heater Rod Materials	6-12
7-1	Axial Thermocouple Distribution	7-8
7-2	Bundle Instrumentation Requirements	7-24
8-1	Test Matrix for 161-Rod Bundle Flow Blockage Task	8-8
9-1	Data Reduction and Analysis Computer Codes for Flow Blockage Task	9-4
9-2	Information Derived From Basic 161-Rod Flow Blockage Task Data	9-11
10-1	Major Milestones for FLECHT SEASET 161-Rod Blocked Bundle Task	10-2



## GLOSSARY

This glossary explains definitions, acronyms, and symbols included in the text which follows.

Analysis -- the examination of data to determine, if possible, the basic physical processes that occur and the interrelation of the processes. Where possible, physical processes will be identified from the data and will be related to first principles.

Average fluid conditions -- average thermodynamic properties (for example, enthalpy, quality, temperature, pressure) and average thermal-hydraulic parameters (for example, void fraction, mass flow rate) which are derived from appropriately reduced data for a specified volume or a specified cross-sectional area

Axial peaking factor -- ratio of the peak-to-average power for a given power profile

Blocked -- a situation in which the flow area in the rod bundle or single tube is purposely obstructed at selected locations so as to restrict the flow

Bottom of core recovery (BOCR) -- a condition at the end of the refill period in which the lower plenum is filled with injected ECC water as the water is about to flood the core

Bundle -- a number of heater rods, including spares, which are assembled into a matrix with CRG-type rods, using necessary support hardware to meet the Task Plan design requirements

Carryout -- same as carryover

Carryout rate fraction -- the fraction of the inlet flooding flow rate which flows out the rod bundle exit by upflowing steam

Carryover -- the process in which the liquid is carried in a two-phase mixture out of a control volume, that is, the test bundle

Computational methods -- the procedure of reducing, analyzing, and evaluating data or mathematical expressions, either by hand calculations or by digital computer codes

Computer code -- a set of specific instructions in computer language to perform the desired mathematical operations utilizing appropriate models and correlations

Computer data acquisition system (CDAS) -- the system which controls the test and records data for later reduction and analysis

Computer tape -- magnetic tapes that store FLECHT SEASET data

Core rod geometry (CRG) -- a nominal rod-to-rod pitch of 12.6 mm (0.496 inch) and outside nominal diameter of 9.50 mm (0.374 inch) representative of various nuclear fuel vendors' new fuel assembly geometries (commonly referred to as the 17 x 17 or 16 x 16 assemblies)

Correlation -- a set of mathematical expressions, based on physical principles and experimental data but resting primarily on experimental data, which describes the thermal-hydraulic behavior of a system

Cosine axial power profile -- the axial power distribution of the heater rods in the CRG bundle that contains the maximum (peak) linear power at the midplane of the active heated rod length. This axial power profile will be used on all FLECHT SEASET tests as a fixed parameter.

Data -- recorded information, regardless of form or characteristic, of a scientific or technical nature. It may, for example, document research, experimental, developmental, or engineering work, or be usable or used to define a design or process or to procure, produce, support, maintain, or operate material. The data may be graphic or pictorial delineations in media such as drawings or photographs, text in specifications or related performance or design type documents, or computer printouts. Examples of data include research and engineering data, engineering drawings and associated lists, specifications, standards, process sheets, manuals, technical reports, catalog item identifications and related information, computer programs, computer codes,

computer data bases, and computer software documentation. The term data does not include financial, administrative, cost and pricing, and management information or other information incidental to contract administration.

Data validation -- a procedure used to ensure that the data generated from a test meet the specified test conditions, and that the instrumentation was functioning properly during the test

Design and procurement -- the design of the system, including the specification (consistent with the appropriate Task Plan) of the material, component, and/or system of interest; and the necessary purchasing function to receive the material, component, and/or system on the test site. This does not preclude Contractor from constructing components and systems on the test site to meet requirements of the Task Plan.

ECC -- emergency core cooling

Entrainment -- the process by which liquid, typically in droplet form, is carried in a flowing stream of gas or two-phase mixture

Evaluation -- the process of comparing the data with similar data, other data sets, existing models and correlations, or computer codes to arrive at general trends, consistency, and other qualitative descriptions of the results

Fallback -- the process whereby the liquid in a two-phase mixture flows counter-current to the gas phase

FLECHT -- Full-Length Emergency Core Heat Transfer test program

FLECHT SEASET -- Full-Length Emergency Core Heat Transfer - Systems Effects and Separate Effects Tests

FLECHT SET -- Full-Length Emergency Core Heat Transfer - Systems Effects Tests

Heat transfer mechanisms -- the process of conduction, convection, radiation, or phase changes (for example, vaporization, condensation, boiling) in a control volume or a system

Hypothetical -- conjectured or supposed. It is understood that this program is concerned with study of physical phenomena associated with reactor accidents that have an extremely low probability and are therefore termed hypothetical.

Loss-of-coolant accident -- a break in the pressure boundary integrity resulting in loss of core cooling water

Model -- a set of mathematical expressions generated from physical laws to represent the thermal-hydraulic behavior of a system. A model rests mainly on physical principles.

PMG -- Program Management Group

Pressurized water reactor (PWR) -- a nuclear reactor type in which the system pressure exceeds saturation pressure, thus preventing gross vapor formation under normal operating conditions

Reduce data -- convert data from the measured signals to engineering units. In some cases the data are manipulated in a simple fashion to calculate quantities such as flows.

Separation -- the process whereby the liquid in a two-phase mixture is separated and detached from the gas phase

Silicon-controlled rectifier (SCR) -- a rectifier control system used to supply dc current to the bundle heater rods

Spacer grids -- the metal matrix assembly (egg crate design) used to support and space the heater rods in a bundle array

Test section -- lower plenum, bundle, and upper plenum

● Test site -- the location of the test facilities where tests will be conducted

Transducer -- the devices used in experimental systems that sense the physical quantities, such as temperature, pressure, pressure difference, or power, and transform them into electrical outputs, such as volts

Unblocked -- the situation in which the flow area in the rod bundle or a single tube is not purposely obstructed



## SECTION 1 SUMMARY

As part of the NRC/EPRI Westinghouse FLECHT SEASET reflood heat transfer and hydraulic program,<sup>(1)</sup> a series of forced flow and gravity feed reflooding tests with flow blockage will be conducted on a 161-rod bundle whose dimensions are typical of current PWR fuel rod arrays. The purpose of these tests will be to test the flow blockage configuration which provided the least favorable heat transfer characteristics in the 21-rod bundle tests, in order to evaluate the additional effect of flow bypass in the larger 161-rod bundle. The 21-rod bundle will be utilized to develop a blockage heat transfer analysis method, and this analysis method will be assessed through comparison and analysis of the 161-rod blocked bundle data.

This document describes the data requirements, instrumentation plan, test facility, test matrix, and data reduction and analysis plans for Task 3.2.3, 161-Rod Bundle Flow Blockage Task, in the FLECHT SEASET program.<sup>(1)</sup>

In this particular test program, a new FLECHT facility will be built to accept a 161-rod bundle whose dimensions are typical of the fuel rod array sizes currently in use by PWR and PWR fuel vendors. This test facility will be very similar to the facility in the 161-rod unblocked bundle task.<sup>(2)</sup> Sufficient instrumentation will be installed in the test facility that mass and energy balances can be performed from the data. The instrumentation plan has also been developed such that local thermal-hydraulic parameters can be calculated from the experimental data. The thermal-hydraulic phenomena occurring during these tests will be identified and analyzed.

1. Conway, C. E., et al., "PWR FLECHT Separate Effects and Systems Effects Test (SEASET) Program Plan," NRC/EPRI/Westinghouse-1, December 1977.
2. Hochreiter, L. E., et al., "PWR FLECHT SEASET Unblocked Bundle, Forced and Gravity Reflood Task: Task Plan Report," NRC/EPRI/Westinghouse-3, March 1978.



## SECTION 2 BACKGROUND

The flow blockage tasks in the FLECHT SEASET program are intended to provide sufficient data and resulting analysis such that the existing Appendix K flow blockage (steam cooling requirements used in PWR safety analyses) can be assessed and replaced by a suitably conservative but physically correct safety analysis model.

Appendix K of 10CFR50.46 requires that any effect of fuel rod flow blockage must be explicitly accounted for in safety analysis calculations when the core flooding rate drops below 2.54 cm/sec (1 in./sec). The rule also requires that a pure steam cooling calculation must also be performed in this case. To comply with this requirement, PWR vendors have developed semiempirical methods of treating fuel rod flow blockage and steam cooling. Experimental data on single-rod and multirod burst test behavior have been correlated into a burst criterion which yields a worst planar blockage given the burst temperature and internal rod pressure of the average power rod in the hot assembly. The test data used to establish this burst criterion indicate that the rod burst is random and noncoplanar, and is distributed over the axial length of the hot zone. When calculating the flow redistribution due to flow blockage, PWR vendors used multi-channel codes to obtain the blocked channel flow.

Simpler models developed by Gambill<sup>(1)</sup> have also been used for flow redistribution calculations. In its ECCS evaluation model, Westinghouse modeled noncoplanar blockage as a series of planar blockages distributed axially over the region of interest, with each plane representing a given percentage blockage. The flow distribution effect was then calculated from a series of proprietary THINC-IV<sup>(2)</sup> computer runs and correlated into a simple expression for flow redistribution. The hot assembly was used as the unit cell in these calculations so that the individual subchannel flow redistribution

1. Gambill, W. R., "Estimate of Effect of Localized Flow Blockages on PWR Clad Temperatures During Reflood," CONF-730304-4, 1972.
2. Chelemer, H., et al., "An Improved Thermal-Hydraulic Analysis Method for Rod Bundle Cores," Nucl. Sci. Eng. 41, 219-229 (1977).

effects generated by the noncoplanar blockage at a given plane are averaged and each subchannel has the same flow reduction. However, it should be remembered that the percentage blockage simulated in these calculations was derived by examination of noncoplanar multirod burst data.

The resulting flow redistribution is then used to calculate a hot assembly enthalpy rise as part of the steam cooling calculation. The resulting fluid sink temperature and a radial conduction fuel rod model is then used to predict the clad peak temperature. Again, the flow redistribution or blockage effects and the steam cooling calculation is only used when the core flooding rate drops below 2.54 cm/sec (1 in./sec). Above this flooding rate, the unblocked FLECHT heat transfer data are used.

The purpose of the flow blockage task will be to provide sufficient experimental data such that a heat transfer model for low flooding rates, with flow blockage, can be developed to replace the current steam cooling calculation. If heat transfer benefit with flow blockage can be justified, a basis may exist for a new heat transfer model for the licensing of commercial nuclear power plants.

A review of flow blockage literature<sup>(1-4)</sup> indicates that there are four primary heat transfer effects which need to be examined for both forced and gravity reflooding:

- Flow redistribution effects due to blockage and their effect on the enthalpy rise of the steam behind the blockage. Bypass of steam flow may result in increased superheating of the remaining steam flow behind the blockage

1. Gambill, W. R., "Estimate of Effect of Localized Flow Blockages on PWR Clad Temperatures During Reflood," CONF-730304-4, 1972.
2. Davis, P. R., "Experimental Studies of the Effect of Flow Restrictions in a Small Rod Bundle Under Emergency Core Coolant Injection Conditions," Nucl. Technol. 11, 551-556 (1971).
3. Rowe, D. S., et al., "Experimental Study of Flow and Pressure in Rod Bundle Subchannels Containing Blockages," BNWL-1771, September 1973.
4. Hall, P. C., and Duffey, R. B., "A Method of Calculating the Effect of Clad Ballooning on Loss-of-Coolant Accident Temperature Transients," Nucl. Sci. Eng. 58, 1-20 (1975).

region. The higher the steam temperature, the lower the rod heat flux and resulting heat transfer coefficient behind the blockage.

- Effect of blockage downstream of the blockage zone and the resulting mixing of the steam and droplet breakup behind the blockage. The breakup of the entrained water droplets will increase the liquid surface area so that the drops will become a more effective heat sink for the steam. The breakup should desuperheat the steam; this would result in greater rod heat transfer behind the blockage zone in the wake of the blockage.
- The heat transfer effects in the immediate blockage zone due to drop impact, breakup, and mixing, as well as the increased steam velocity due to blockage flow area changes. The drop breakup is a localized effect primarily caused by the blockage geometry; it will influence the amount of steam cooling which can occur farther downstream of the blockage.
- Effect of blockage on the upstream region of the blockage zone due to steam bypass, droplet velocities, and sizes

In simpler terms, the flow blockage heat transfer effects are a combination of two key thermal-hydraulic phenomena:

- A flow bypass effect, which reduces the mass flow in the blocked region and consequently decreases the heat transfer
- A flow blockage effect, which can cause flow acceleration, droplet breakup, improved mixing, steam desuperheating, and establishment of new boundary layers, which consequently increases the heat transfer

These two effects are dependent on blockage geometry; they counteract each other such that it is not evident which effect dominates over a range of flow conditions.

It is expected that the tests planned in the 161-rod bundle task will provide sufficient data for the analysis of flow blockage and flow bypass effects on heat transfer.

The tests planned under the 161-rod bundle flow blockage task will utilize a new core rod geometry (CRG)<sup>(1)</sup> that is typified by the Westinghouse 17 x 17 fuel rod design (table 2-1). This CRG is representative of all current vendors' PWR fuel assembly geometries.

TABLE 2-1  
COMPARISON OF PWR VENDORS' FUEL  
ROD GEOMETRIES (OLD AND NEW)

Vendor	Dimension	
	Rod Diameter [mm (in.)]	Rod Pitch [mm (in.)]
NEW FUEL ASSEMBLIES (CRG)		
Westinghouse	9.5 (0.374)	12.6 (0.496)
Babcock & Wilcox	9.63 (0.379)	12.8 (0.502)
Combustion Engineering	9.7 (0.382)	12.9 (0.506)
OLD FUEL ASSEMBLIES		
Westinghouse	10.7 (0.422)	14.3 (0.563)
Babcock & Wilcox	10.9 (0.430)	14.4 (0.568)
Combustion Engineering	11.2 (0.440)	14.7 (0.580)

The tests performed in this task are classified as separate effects tests. In this case, the bundle is isolated from the system and the thermal-hydraulic conditions are prescribed at the bundle entrance and exit. Within the bundle, the dimensions are full scale (compared to a PWR) with the exception of overall radial dimension. The low mass housing used in this test series is designed to minimize the wall effects such that the rods one row or more away from the housing in the FLECHT bundle are unaffected by the housing. Examination of the housing performance for the skewed axial profile FLECHT tests<sup>(2)</sup> indicates that it does simulate this radial boundary condition fairly

1. The CRG is defined in this program as a nominal rod-to-rod pitch of 12.6 mm (0.496 in) and outside nominal diameter of 9.5 mm (0.374 in.), representative of various nuclear fuel vendors' new fuel assembly geometries and commonly referred to as the 17 x 17 or 16 x 16 assemblies.
2. Rosal, E. R., et al., "FLECHT Low Flooding Rate Skewed Test Series Data Report," WCAP-9108, May 1977.

well and that only the rods immediately adjacent to the housing are affected by the housing presence. To preserve proper thermal scaling of the FLECHT facility with respect to a PWR, the power to flow area ratio is made to be nearly the same as that of a PWR fuel assembly. In this fashion, the steam vapor superheat, entrainment, and fluid flow behavior should be similar to that in a PWR bundle environment for the same boundary conditions.



## SECTION 3

### TASK OBJECTIVES

The objectives of the 161-rod bundle test heat transfer tests are twofold:

- To obtain, evaluate, and analyze thermal-hydraulic data using 161-rod bundles to determine the effects of flow blockage and flow bypass on reflood heat transfer
- To assess/develop an analytical or empirical method for use in analyzing the blocked bundle heat transfer data

To achieve these objectives, the blockage configuration which provides the least favorable heat transfer characteristics in the 21-rod bundle task will be placed in the 161-rod bundle test facility. If no measurable difference is observed, then the blockage configuration which appears most common in the out-of-pile or in-pile burst tests will be used. The configurations which have been chosen for the 161-rod bundle and the basis for the choice are given in section 4. Although many different distributions of the blockage sleeves are possible, these combinations have been reduced to two test series in the 161-rod bundle through engineering judgment, examination of postulated flow blockage effects (section 2), and examination of the existing flow blockage model or method of calculation provided by Hall and Duffey.<sup>(1)</sup> The two 161-rod bundle test series are given in table 3-1, with an explanation of the different effects which are expected to be observed from the experiments.

The sleeves, which will be identical to those used in the 21-rod bundle tests, will be smooth, and no attempt will be made to simulate the burst opening in the clad. Reflood tests have been conducted with no blockage in an identical facility at the same

1. Hall, P. C., and Duffey, R. B., "A Method of Calculating the Effect of Clad Ballooning on Loss-of-Coolant Accident Temperature Transients," Nucl. Sci. Eng. 58, 1-20 (1975).

TABLE 3-1

BLOCKAGE CONFIGURATIONS TO BE TESTED IN 161-ROD BUNDLE

Configuration	Description	Comments
1	Unblocked	Reference (Task 3.2.1)
2	Noncoplanar blockage on two 21-rod bundle islands with the reference strain and distribution	This test series provides the flow bypass effect relative to the 21-rod bundle.
3	Blockage on two 21-rod bundle islands with a strain larger than the reference strain	This test provides a variation in the flow bypass effect relative to configuration 2

thermal-hydraulic conditions to serve as a basis for evaluation of the flow blockage heat transfer.<sup>(1)</sup>

Rod bundle instrumentation factors, such as heater rod thermocouple location and instrumented rods, will be nearly the same for each blockage configuration. The instrumentation in the test facility loop, housing, flow system, and controls will be identical. By conducting replicate tests at the same conditions in the same facility, the local heat transfer on a given blocked rod can be compared to that on an unblocked rod to obtain the effect of the flow blockage and flow bypass. Comparisons of this kind, on a one-to-one basis, will allow the development of a blockage heat transfer model.

To help ascertain the heat transfer effect of the flow blockage configuration relative to the unblocked bundle, two-phase forced reflooding and gravity reflooding tests will be performed on each blockage configuration. The COBRA-IV code model of the 161-rod bundle will be used to calculate the single-phase flow redistribution in and around the blockage zone for each configuration. In this fashion, the measured local heat transfer can be associated with a calculated local flow (single-phase) from COBRA; this should help explain the heat transfer behavior.

The COBRA-IV calculations to be performed will be single-phase steam, flow redistribution calculations. Although the flow during reflooding is two-phase for most of the test time, the flow regime which will exist at the quench front is a highly dispersed flow. Typical void fractions above the quench front for the low flooding rate test conditions given (section 9) are on the order of 0.95. Therefore, steam flow is in the continuous phase and the relatively few droplets may not strongly affect the macroscopic (subchannel average) steam flow and/or flow redistribution. Sample calculations have been performed and reported in the FLECHT SEASET program plan<sup>(2)</sup> on the single-phase flow redistribution effect on droplets. It was shown that, except

1. Hochreiter, L. E., et al., "PWR FLECHT SEASET Unblocked Bundle, Forced and Gravity Reflood Task: Task Plan Report," NRC/EPRI/Westinghouse-3, March 1978.
2. Conway, C. E., et al., "PWR FLECHT Separate Effects and Systems Effects Tests (SEASET) Program Plan," NRC/EPRI/Westinghouse-1, December 1977.

for the extremely small drops, the liquid phase does not redistribute with the steam flow. The drops have sufficient inertia to continue their flight through the blockage zone without any significant deviations.

Most of the tests in the 161-rod bundle test matrix will be constant forced flooding reflood tests. The test conditions represent typical safety evaluation model assumptions and initial conditions. The forced flooding tests will be used primarily to help evaluate the blockage model or method of analysis as developed in the 21-rod bundle tests through comparisons with identical unblocked forced reflooding tests and the associated COBRA-IV flow redistribution analysis. In a similar fashion, the gravity-driven reflood tests will permit one-to-one comparison with the unblocked gravity reflood tests in the 161-rod bundle test facility for each blockage configuration. The data analysis emphasis in these experiments will be on calculation of the fluid conditions at each instrumented bundle axial plane, to assess and evaluate the 21-rod bundle blockage model and provide a mechanistic explanation of the flow bypass effect in the bundle.

## SECTION 4

# BLOCKAGE SHAPE AND TEST CONFIGURATIONS

### 4-1. GENERAL

The high internal pressure and temperature of fuel rods during a postulated PWR LOCA are expected to cause the fuel rods to swell and burst. The resulting rod deformation would reduce the fluid flow area in the rod array. The shape of the rod swelling and burst is referred to as a blockage shape. This flow area reduction (or flow blockage) is governed by the shapes and spatial distribution of blockage. Therefore blockage shapes and their spatial distribution must be chosen properly to simulate the thermal-hydraulic conditions of the fluid flow in the blocked rod array. The number of selected blockage shapes should be minimized to make blockage tests feasible, but it must be sufficient to address the important effects of the flow blockage on heat transfer. The spatial blockage distribution must also be chosen to represent realistic situations and to provide fundamental understanding of blockage effects on the local heat transfer.

The results of several single-rod and multirod burst tests are available. These results were used to define the blockage shapes to be simulated in the 21-rod blockage task. Discussions with NRC and EPRI were also considered in the choice of blockage shape. A sleeve shape to be used in the present task will be chosen from the sleeve shapes used in the 21-rod blockage test. The blockage shape so determined will be simulated by stainless steel sleeves which can be attached to rods to effect flow blockage. Blockage configurations (spatial blockage distribution) for this task have been selected to provide as much understanding of blockage effects as possible. Further, an approach to better utilize the 21-rod bundle results in the design of the 161-rod bundle has also been considered, because of the desirability of a geometric similarity between the 21-rod and 161-rod bundles. This similarity is expected to provide a better basis for data analysis and for the understanding of bypass effects.

These considerations are discussed in the following paragraphs.

#### 4-2. BLOCKAGE SHAPES

Several out-of-pile and in-pile burst tests have been executed to aid in the understanding of rod burst phenomena during a LOCA. Out-of-pile tests have employed several heating methods to simulate rod heatup during a reflooding period. The heating methods include a stiff internal heater rod (continuous rigid heating element) method, external radiant heating, and direct resistance heating. The external radiant heating and direct resistance heatup are believed to distort the thermal response of the clad during its deformation. The internal heater rod may reduce the clad temperature non-uniformity which is expected in the real situation of stacked fuel pellets. Although an out-of-pile test method is not ideal, it is generally agreed that an internal heater method is most representative of the real situation. Therefore the results from the tests using internal heater rod methods were reviewed in the 21-rod blockage task to provide a basis for defining blockage shapes. Very limited in-pile test results were also reviewed.<sup>(1)</sup>

The available results from several rod burst tests showed that there were two distinctive rod swelling patterns, depending on the burst temperature. This is due to the existence of two phases of Zircaloy, whose material properties are quite different from each other. Zircaloy is in the alpha phase at temperatures of less than 830°C (1529°F) and in mixed phase of alpha and beta types between 830°C and 970°C (1529°F and 1779°F). Above 970°C (1779°F), Zircaloy is in beta phase. Alpha phase Zircaloy has anisotropic strain properties. Therefore, the resulting deformation of alpha phase Zircaloy is very sensitive to minor temperature irregularities in both circumferential and axial directions. This anisotropic property causes rod bowing, in addition to swelling and burst. Although the burst phenomenon in the mixed phase is not well understood, this burst range can be treated essentially as alpha phase burst because of the nonisotropic property of alpha phase. Beta phase Zircaloy has an isotropic strain property which causes more or less uniform clad swelling. Thus the property of alpha phase Zircaloy is different from that of beta phase Zircaloy. This difference gives a quite different clad swelling phenomenon for each phase. That is, alpha phase swelling has a long nonconcentric shape in contrast to the beta phase

---

1. Hochreiter, L. E., et al., "PWR FLECHT SEASET 21-Rod Bundle Flow Blockage Task: Task Plan Report," NRC/EPRI/Westinghouse-5, March 1980.

swelling of a relatively short concentric shape. Therefore, two typical blockage shapes representing alpha and beta phase swelling were chosen to be simulated in the 21-rod tests. Schematic drawings of the two blockage shapes are shown in figures 4-1 and 4-2. Detailed explanations of the choices are given in the 21-rod bundle flow blockage task plan.<sup>(1)</sup>

The 21-rod bundle task was designed to compare the blockage effects of the two sleeves and screen out one blockage shape which gives the least favorable heat transfer characteristics downstream of the blockage zone. The resulting blockage shape will be used in the 161-rod bundle blockage task.

#### 4-3. BLOCKAGE CONFIGURATIONS

The 161-rod blocked bundle task will examine the reflooding phenomenon in a large blocked bundle with ample flow bypass. The effects of blockage on heat transfer can be accounted for by two counteracting phenomena: flow depletion in the blockage zone due to flow bypass, and increased turbulence in the blocked area due to the flow disturbance. Bypass flow is expected to reduce heat transfer in the blocked region because of the coolant depletion; however, the increased turbulence and possible enhanced droplet disintegration may enhance heat transfer in the zone. Therefore, it is necessary to determine the dominant effect under various thermal-hydraulic conditions for a clear understanding of the blockage effect on heat transfer. This test series will study these effects to determine the relative importance of flow bypass and local disturbance. This large-bundle test is especially designed to maximize the usefulness of the small-bundle (21-rod) test results.

#### 4-4. Test Blockage Configurations

This large bundle will be used primarily to study the bypass effect, which cannot be investigated in the 21-rod bundle. The unblocked bundle tests will be used as reference tests for this blockage test series. To study the blockage effect, blockages in the

---

1. Hochreiter, L. E., et al., "PWR FLECHT SEASET 21-Rod Bundle Flow Blockage Task: Task Plan Report," NRC/EPRI/Westinghouse-5, March 1980.

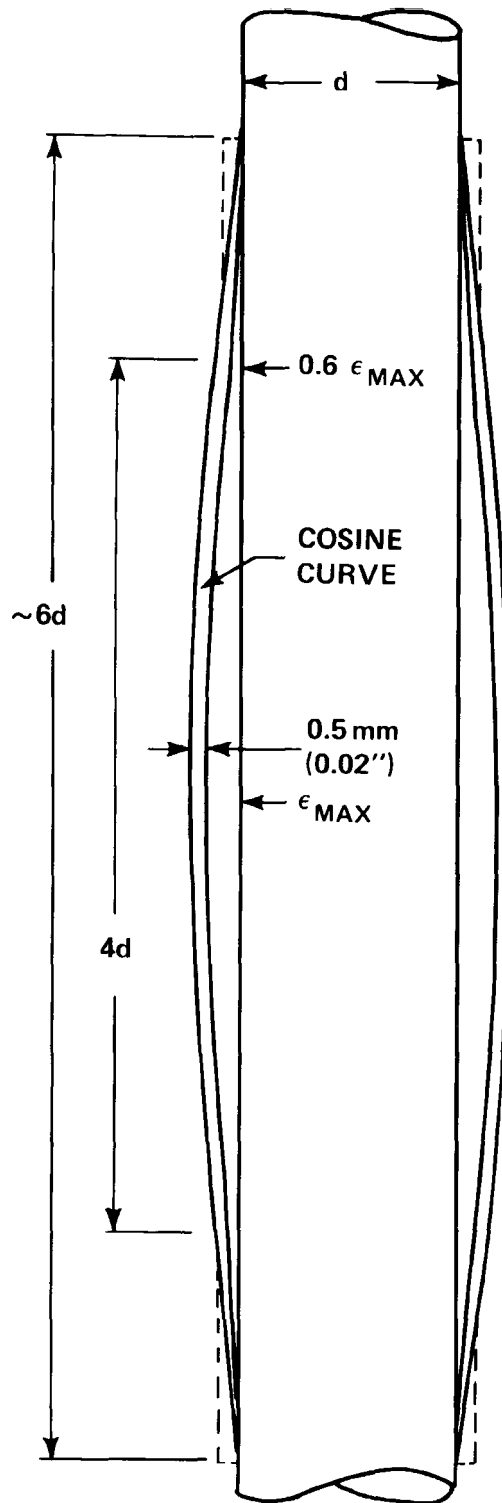

Figure 4-1. Blockage Sleeve for Beta Phase Swelling

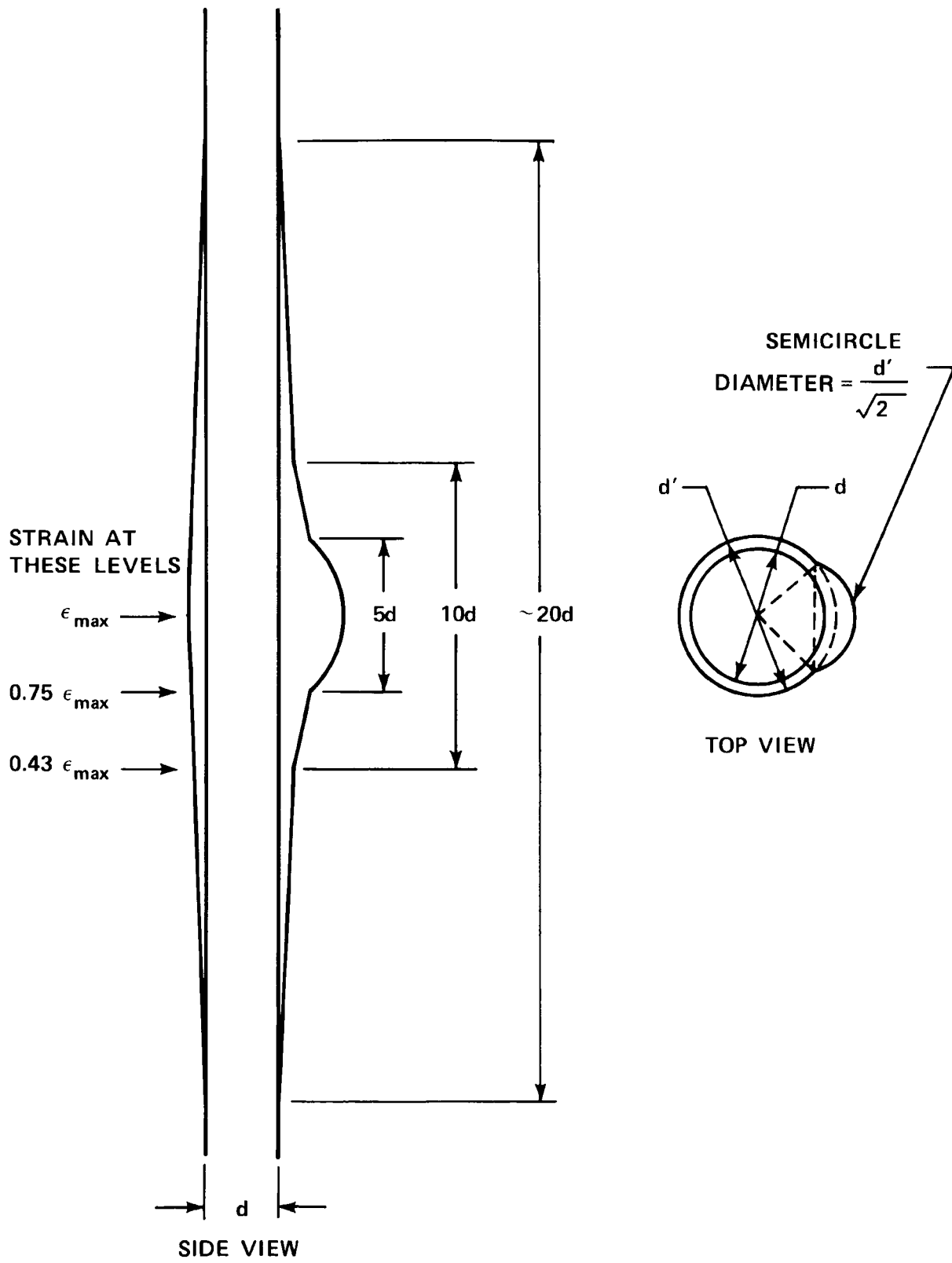

Figure 4-2. Shape of Nonconcentric Sleeve

bundle will be distributed to produce maximum flow bypass while significant flow disturbance is achieved.

The following two blockage configurations are planned to be tested:

- Blockage in the part of the bundle with the reference strain and axial configuration
- Blockage in the part of the bundle with the reference axial configuration and a strain larger than the reference strain

The first configuration is a bypass effect test with a reference blockage distribution, and the second is a parametric study of the blockage distribution effect.

#### 4-5. Noncoplanar Blockage Distribution

A noncoplanar blockage test configuration requires a method to axially distribute blockage in a noncoplanar fashion. The following paragraphs describe the method of distributing the blockage sleeves on the heater rods. The objective is to locate blockage sleeves in the bundle in such a manner that the statistics of the location coincide with the expected deformation and bursts of a PWR. The basis of this approach is the following statement from the ORNL multirod burst test results: "Posttest deformation measurements showed excellent correlation with the axial temperature distribution, with deformation being extremely sensitive to small temperature variations."<sup>(1)</sup>

Burman and Olson<sup>(2)</sup> have studied temperature distributions on rods in a bundle. Their method can be employed to determine the statistics of burst locations in the bundle.

1. Chapman, R. H., "Significant Results From Single-Rod and Multirod Burst Tests in Steam With Transient Heating," paper presented at Fifth Water Reactor Safety Research Information Meeting, Germantown, MD, November 7-10, 1977.
2. Burman, D. L., and Olson, C. A., "Temperature and Cladding Burst Distributions in a PWR Core During LOCA," paper presented at the Specialists Meeting on the Behavior of Water Reactor Fuel Elements Under Accident Conditions, Spatind (Nord-Torpa), Norway, September 13-16, 1976.

The burst locations so determined were selected without considering the grid effect on burst location which was observed in the German REBEKA tests.<sup>(1)</sup> It was found that rod burst locations were shifted toward the fluid flow direction because of enhanced heat transfer downstream of the grids.

Incorporation of this hydraulic effect on burst location requires knowledge of the time of rod burst. Rod bursts during blowdown are expected to occur at locations shifted downward, because of the downward fluid flow at the time. Burst at the end of blowdown may not be affected by fluid flow because there is virtually no fluid flow. During the refill and reflood phases, rod bursts would occur at locations shifted upward.

Rods in a PWR can burst at any phase of a LOCA transient, depending on power distribution, operating life, type of break, material strength uncertainties, and the like. Therefore, the hydraulic effect can be incorporated into the determination of burst locations in several ways. On the other hand, the most interesting phenomenon in the present study is local heat transfer under a typical blockage distribution; such a situation can be achieved without considering any hydraulic effect. This case is considered to be most typical when bursts occur during all three phases: blowdown, refill, and reflood.

To determine burst locations, it is assumed that all rods to be deformed have the same or similar temperature distribution. The ORNL multirod burst tests showed that there were no interactions among rods during burst, so it may be assumed that each rod in a bundle bursts independently. Then the characteristics of one rod may be used to infer the behavior of the rod bundle.

A rod is divided into several sections with the same interval. Burman and Olson computed the probability that a certain section (say, the *i*-th increment) of a fuel rod is at the highest temperature in the rod as follows:

$$\int_0^{\infty} \left\{ \frac{1}{\sigma_T \sqrt{2\pi}} \exp \left[ -\frac{(\mu_i - T)^2}{2\sigma_T^2} \right] \right. \prod_{j=1, N}^j \left. \frac{1}{\sigma_T \sqrt{2\pi}} \int_0^T \exp \left[ -\frac{-(\mu_i - t)^2}{2\sigma_T^2} \right] dt \right\} dT \quad (4-1)$$

1. Wiehr, K., et al., "Fuel Rod Behavior in the Refill and Flooding Phase of a Loss-of-Coolant Accident," CONF-771252-5, December 1977.

Here  $\sigma_T$  and  $\mu_i$  are the standard deviation of local temperature and the mean temperature at the  $i$ -th increment, respectively. It can be seen that these two characteristics ( $\sigma_T$  and  $\mu_i$ ) must be known to compute the local probability of highest temperature. As ORNL showed, this highest-temperature location can be interpreted as the burst location.

The mean temperature distribution required in equation (4-1) is the axial mean temperature of a nuclear fuel rod at the time of rod burst. The standard deviation of local temperature is included to account for the local temperature fluctuation. Burman and Olson assumed that the fluctuation is normally distributed.

The local temperature can be divided into two components:

$$T_{\text{local}} = \bar{T}_{\text{local}} + T'_{\text{local}}$$

where  $\bar{T}_{\text{local}}$  and  $T'_{\text{local}}$  are the mean and variation of local temperature, respectively. The mean temperature is obtained from the axial mean temperature distribution. The local temperature variation is a function of the following several effects:

-- Manufacturing effect

- Initial fuel pellet density
- Fuel pellet diameter
- Fuel enrichment
- Manufacturing variables which affect fuel densification
- Clad local ovality
- Fuel pellet chemical bonding

-- In-pile effect

- Fuel pellet radial offset within clad
- Fuel pellet cracking
- Fuel densification

Burst probabilities at each increment of rod can be computed by equation (4-1) with the inputs of  $\sigma_T$  and  $\mu_i$ .

Multiplying the probabilities by the total rod number gives theoretical burst numbers at the corresponding axial increments. These numbers are usually not integers. Therefore, for practical purpose, these numbers are transformed to integers to satisfy the requirement that the total burst number is the same as the total rod number. These integer numbers indicate how many sleeves should be located at specific axial increments. An increment (i-th) is then selected at random. Since it is known from the above calculation that  $N_i$  rods have bursts at this increment,  $N_i$  rods are selected at random. Each of these selected rods has a sleeve on the i-th increment. Then another increment and corresponding rods are selected at random. This procedure is repeated until all the axial increments where bursts occur have been considered.

A computer program has been written to execute this procedure for selection of sleeve locations. This program, tentatively called COFARR (Coolant Flow Area Reduction), can calculate subchannel blockage with given input strain information on the blockage sleeve. This program and relevant details are described in detail in the 21-rod bundle task plan.<sup>(1)</sup>

#### 4-6. Partially Blocked Bundle

Partial blockage in the large bundle will be used to study bypass effects on the heat transfer in the blocked channels of a rod array. One problem is how to arrange blockage in the bundle with sufficient bypass area so as to not force fluid through the blocked zone because of bundle size. Several methods could be used to produce a large bypass area in the bundle. However, several bundle limitations exist which help determine how the blockage should be arranged laterally. These bundle limitations are as follows:

- The large bundle has only one symmetry line because of thimble locations (figure 4-3).

---

1. Hochreiter, L. E., et al., "PWR FLECHT SEASET 21-Rod Bundle Flow Blockage Task: Task Plan Report," NRC/EPRI/Westinghouse-5, March 1980.

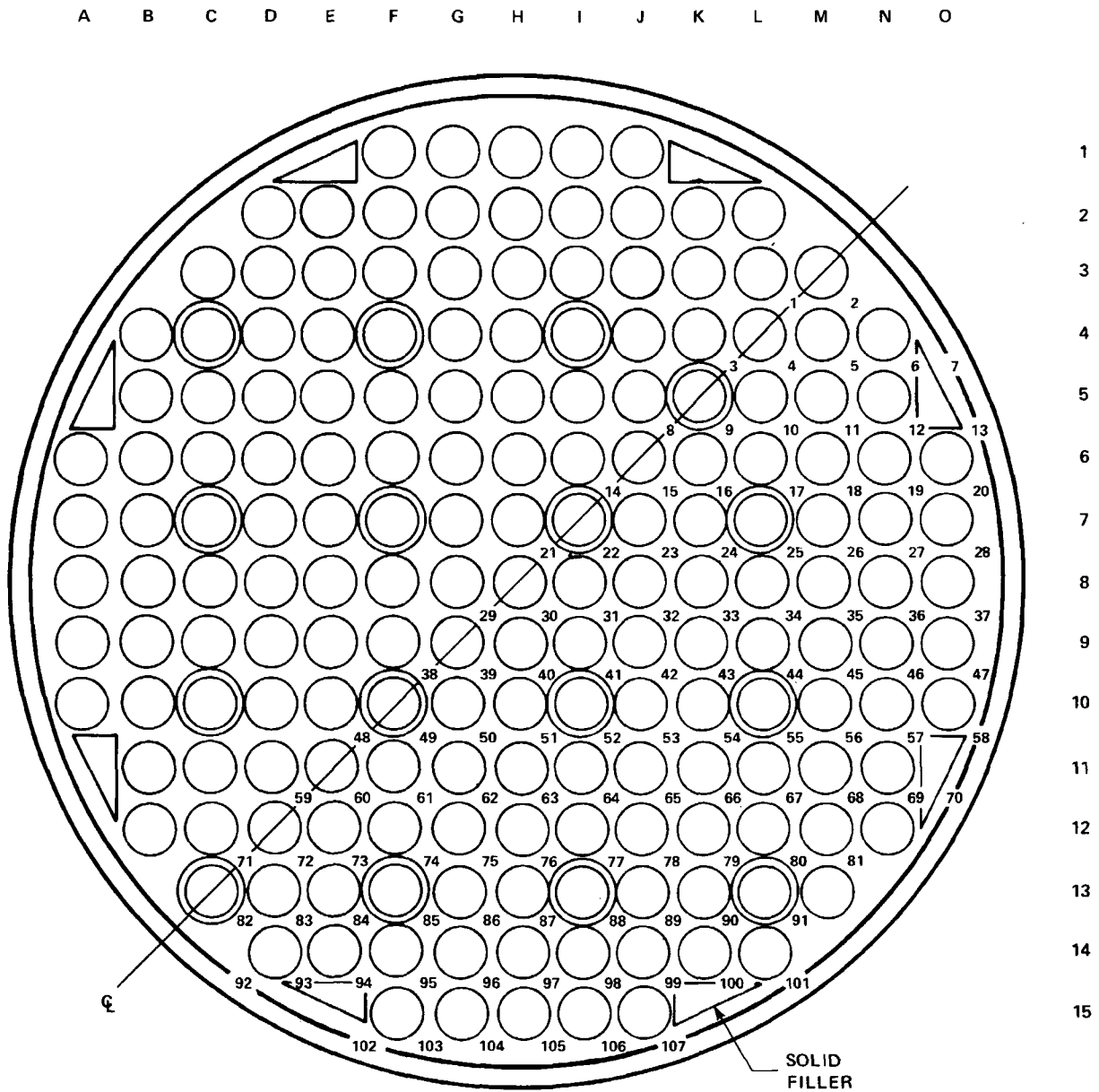

Figure 4-3. Bundle and Addresses of Subchannels Showing Line of Symmetry

- The large-bundle test should be linked to the small-bundle test (21-rod) to better utilize information.
- Lateral symmetry in the blocked bundle for the bypass area and blockage zone is desirable in view of possible data scattering and computer time for flow calculations.
- The blockage zone must be large enough to provide a detectable flow field distortion and a maximum flow depletion in the blocked zone.

With the above points in mind, three different blockage-bypass schemes have been considered; they are shown schematically in figure 4-4. For the first case, the blockage is at the half of the bundle divided by the symmetry line. Therefore this blocked bundle has no lateral symmetry. The second case blocks half of the bundle, providing symmetry. The third blocks two 21-rod clusters which are symmetrical to each other with respect to the symmetry line.

Figure 4-5 shows blockage-bypass case 1. This case has an advantage of direct data comparison between blocked and unblocked subchannels using the bundle (before blockage) symmetry. For example, the heat transfer characteristics measured at A and B in figure 4-5 can provide the blockage effect directly with all the other parameters the same. But the flow in this partially blocked bundle cannot be readily simulated by COBRA because of the limited computer capacity and lack of symmetry of the blocked bundle. However, COBRA calculations show that when half of the bundle is blocked (case 2), the fluid near the wall at the blocked side tends to be trapped in the blockage zone. Thus this case may have higher fluid flow in the blockage zone than the case where there is no wall. These shortcomings make this blockage-bypass configuration undesirable.

The second blockage-bypass case is shown in figure 4-6. The symmetry of the blocked bundle allows COBRA simulation of fluid flow in this bundle. This case also provides an indication of the magnitude of experimental uncertainty by comparing the behavior of identical subchannels, such as those at A and B in figure 4-6. In contrast to the first case, this case cannot provide blockage effects when all the other parameters are the same. This problem can be avoided, however, by lumping several rods to get several similar rod clusters.

CASE 1

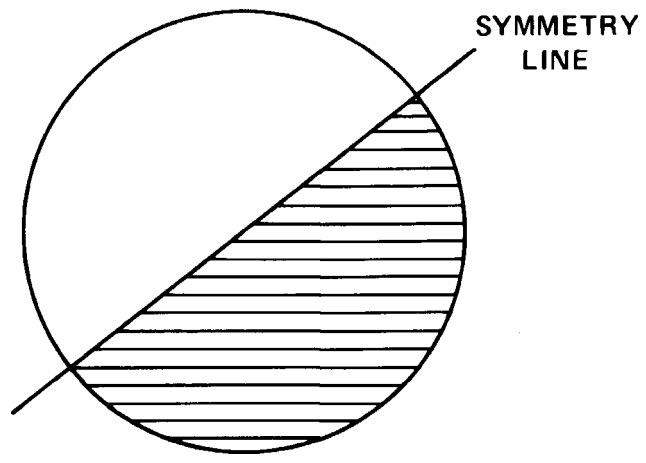

CASE 2

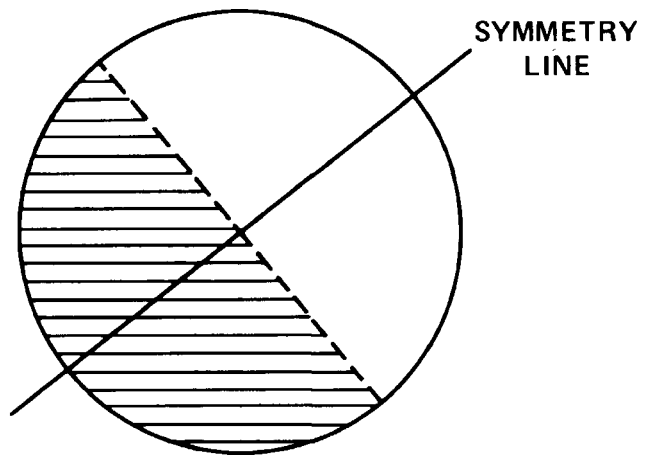

CASE 3

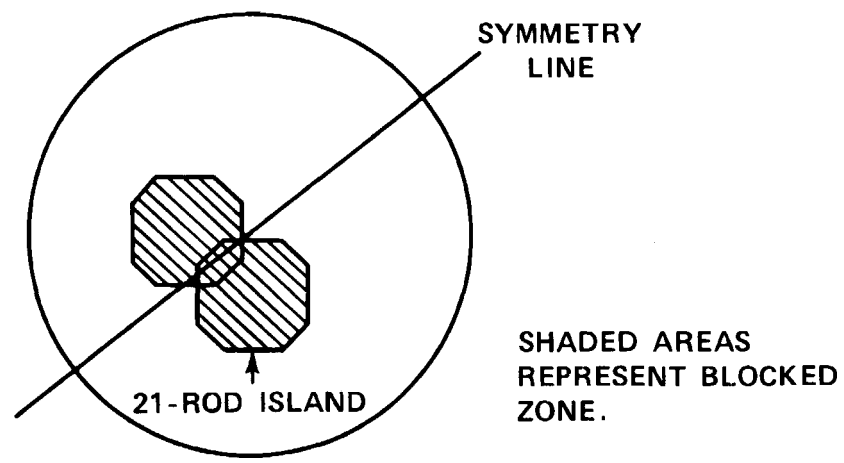

Figure 4-4. Partial Blockage-Bypass Cases

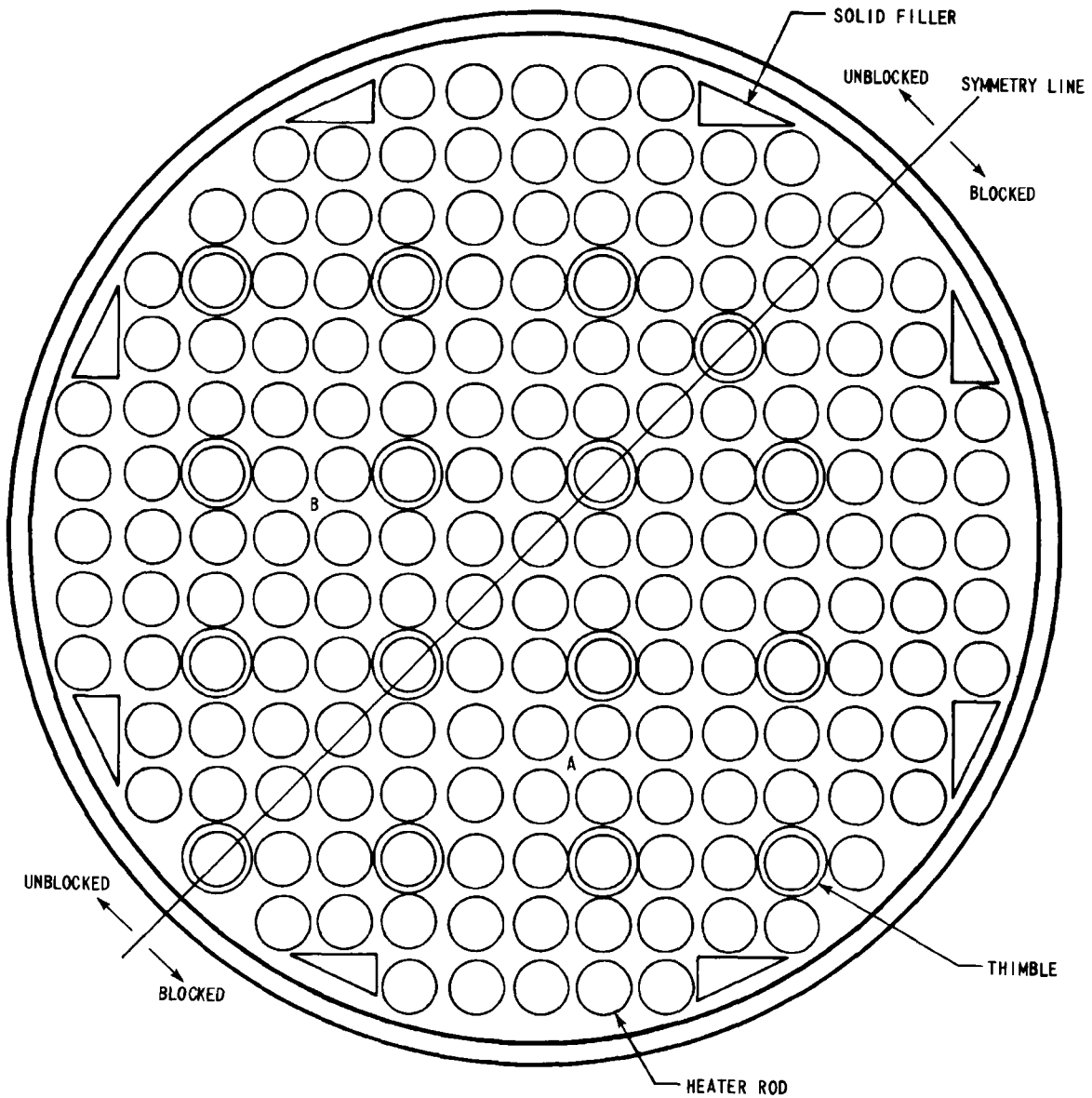

Figure 4-5. Partial Blockage Case 1

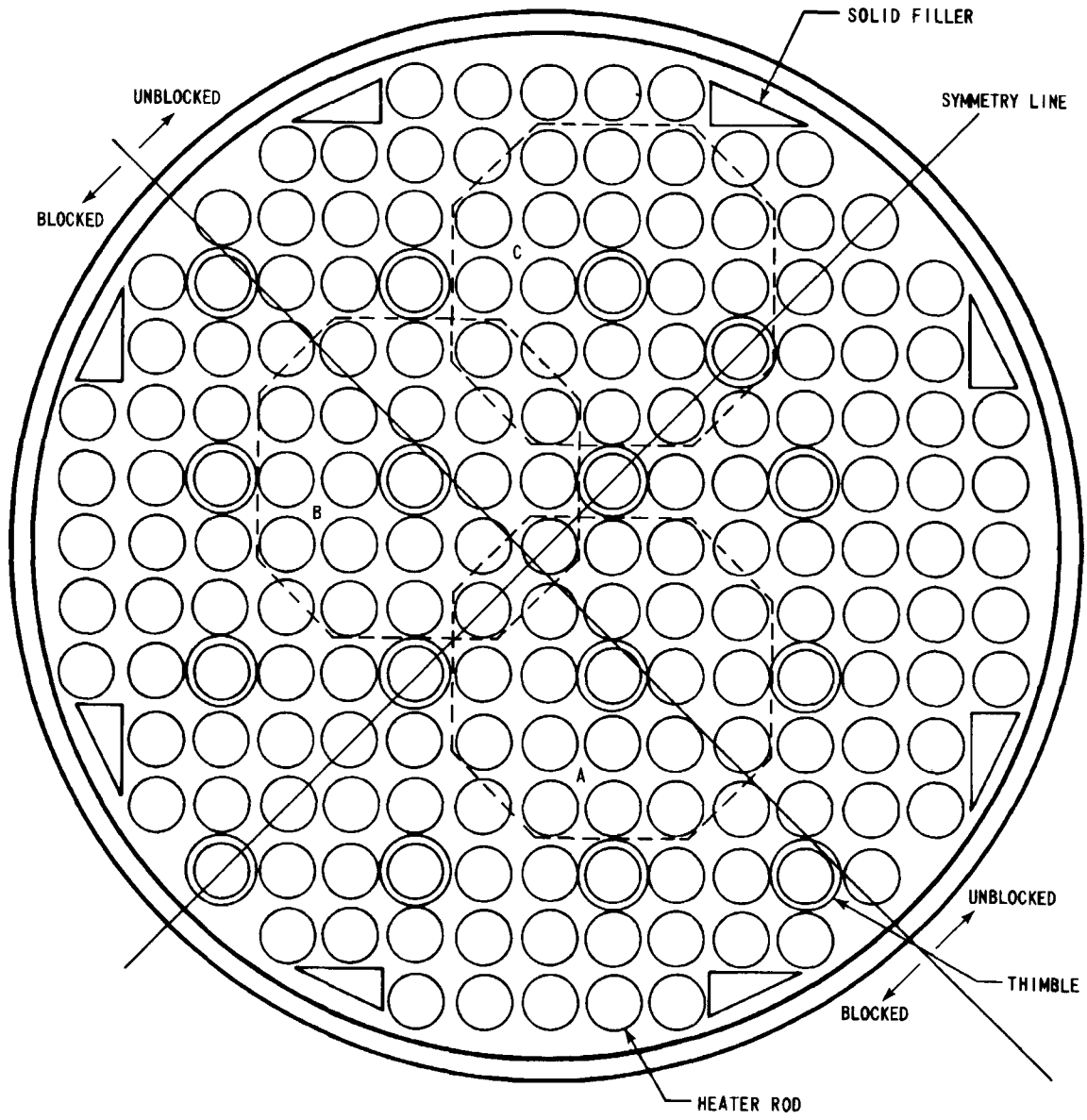

Figure 4-6. Partial Blockage Case 2

One way to lump the rods is by dividing the large bundle into 21-rod bundle clusters. Three such clusters are shown in figure 4-6 by the dotted lines. Each cluster is almost the same as the others. Therefore the fluid flow in each cluster can be considered the same and it is possible to locate "corresponding subchannels" in each cluster, such as subchannels A, B, and C in figure 4-6. Then the comparison between channels A or B and C is considered good enough to give the blockage effect with all the other parameters the same. As mentioned in case 1, however, the half-bundle blockage gives higher flow rates in the blocked zone because of the trapped fluid near the wall in the blocked side.

Case 3 is shown in figure 4-7. For this configuration, the inner rods surrounded by solid lines have sleeves to block subchannels, as in the 21-rod bundle blockage distribution. This blockage scheme has all the advantage of case 2 without any additional penalties. Furthermore, it has a higher bypass area because of the smaller and isolated island blockage zone.

Comparisons of the blockage schemes have been made by calculating flow rates in subchannels by COBRA-IV-I. The blockage patterns compared are shown in figure 4-8 (case 3) and figure 4-9 (case 2). The figures show subchannel addresses and sleeve locations. The sleeve locations in the 21-rod cluster were chosen using COFARR. The sleeve locations for case 2 were determined by considering that the blocked half bundle is a set of 21-rod clusters, as schematically shown in figure 4-9. The average axial blockage distribution of the 21-rod cluster with concentric sleeves of 32.6-percent strain is shown in figure 4-10. Comparison of the sleeve locations shows that four subchannels (38, 50, 51, and 63) have the same axial blockage distribution in both cases. Flow rates in three subchannels (50, 51, and 63) are compared in figures 4-11, 4-12, and 4-13. These results show that case 3 has lower flow rates in the similarly blocked zone, and the flow disturbance or depletion in the zone is almost comparable to that of the half-bundle blockage.

The above discussions are summarized in table 4-1. On this basis, case 3 is believed the best way to achieve a partial blockage in the large bundle. It should be noted again that this case provides the lowest flow rates in the blocked subchannels.

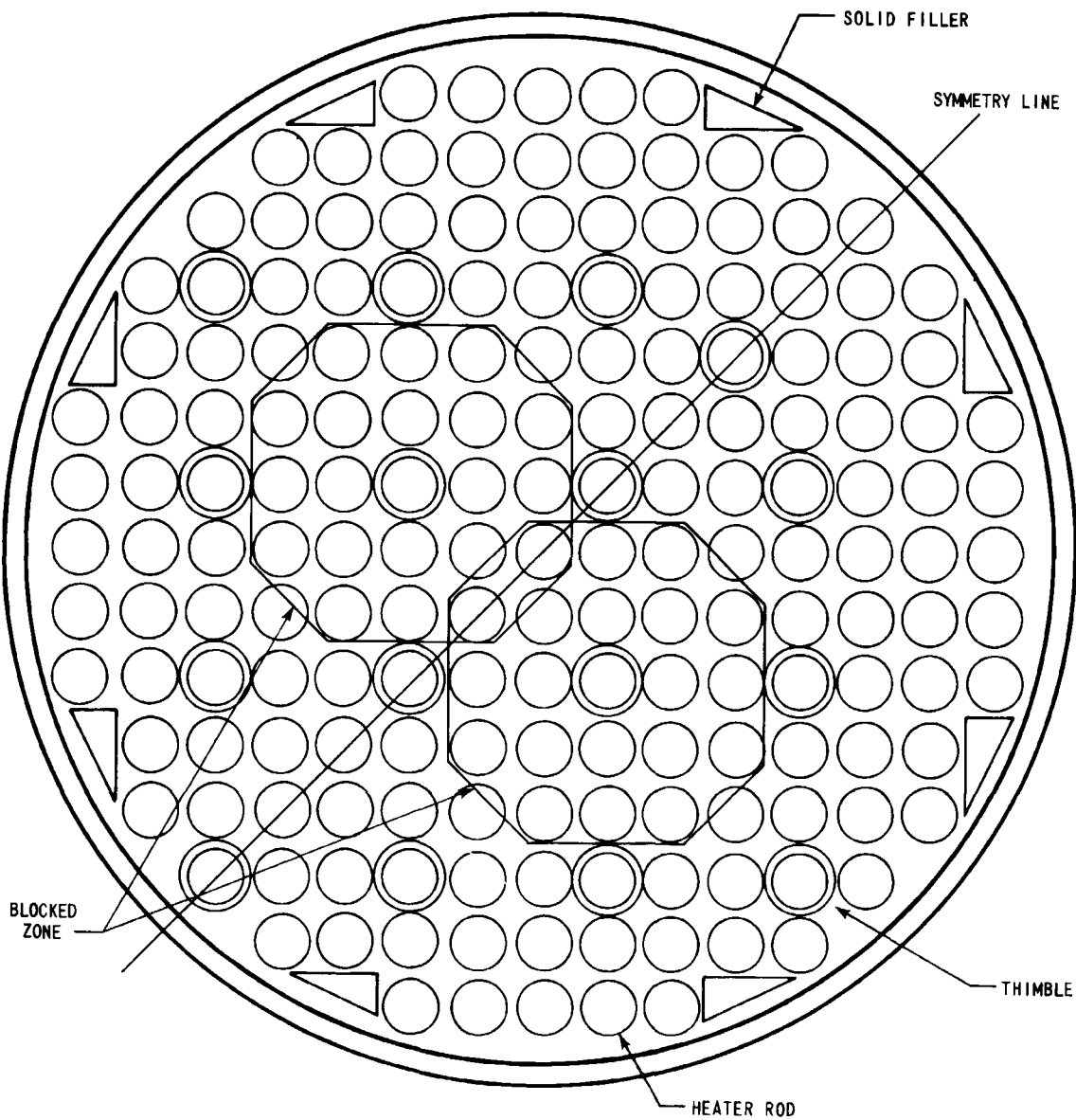
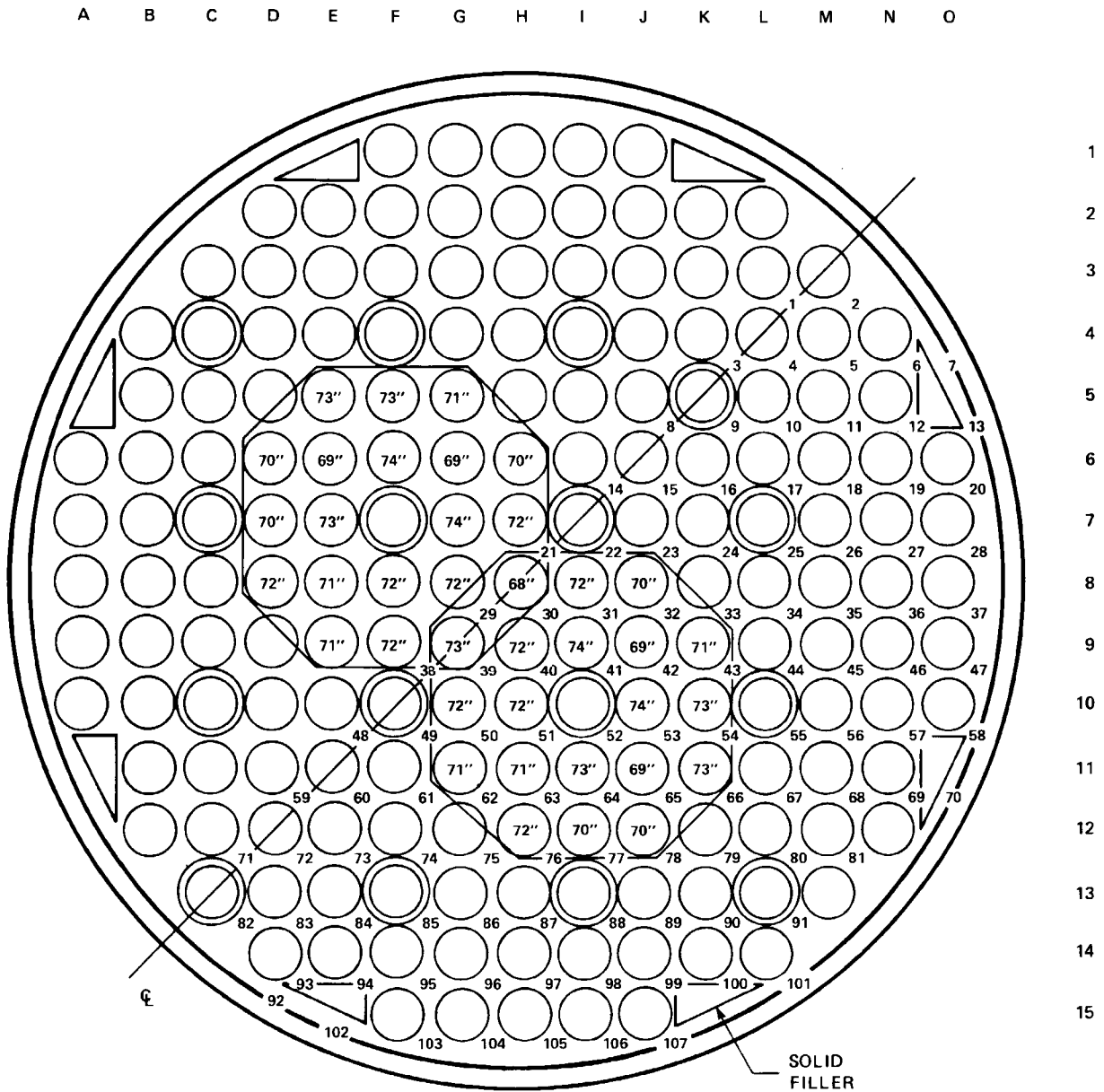
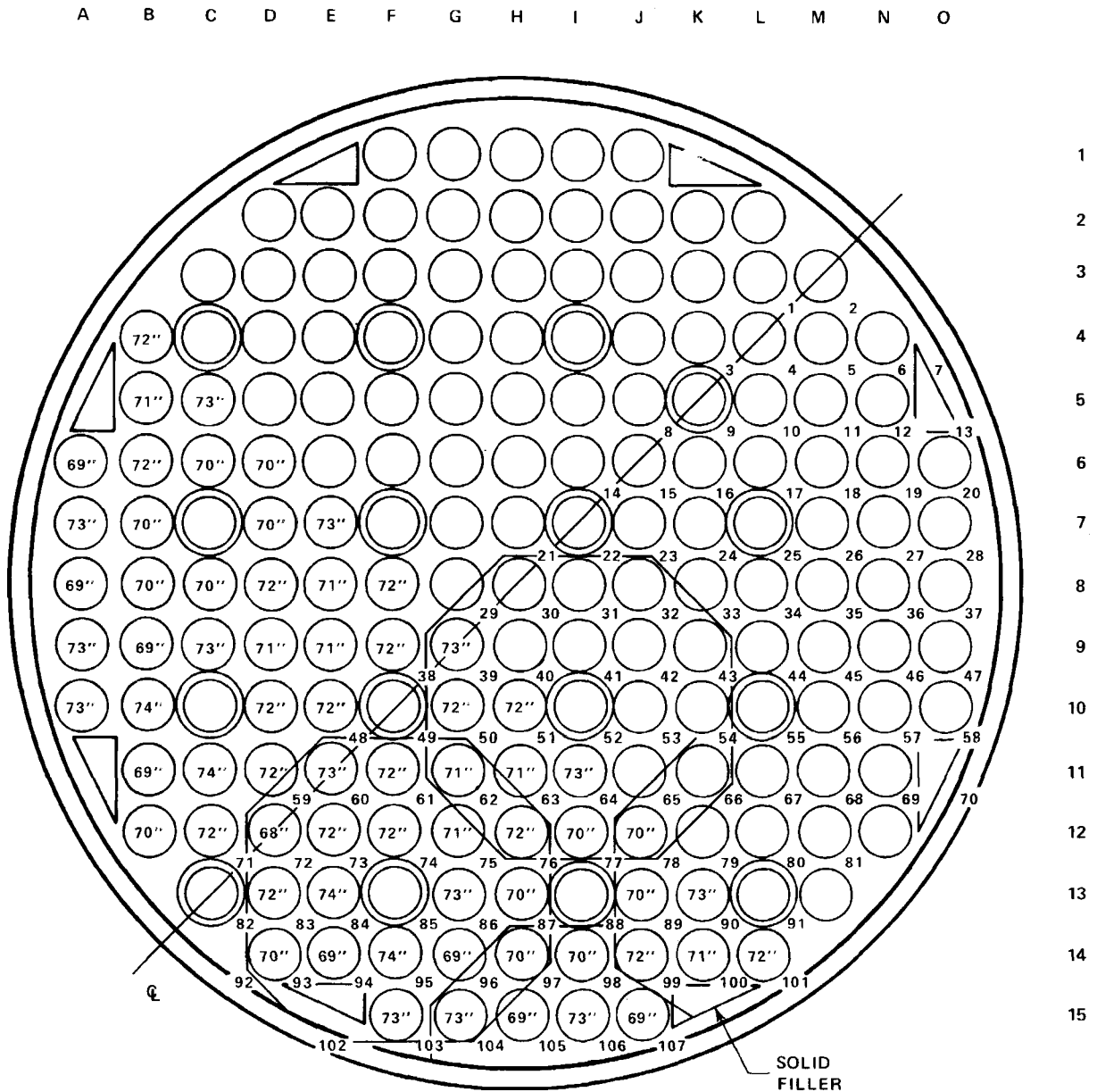

Figure 4-7. Partial Blockage Case 3



THE NUMBERS IN RODS ARE SLEEVE LOCATIONS. FOR EXAMPLE,  
 (72") - MAXIMUM STRAIN OF THE SLEEVE ON THE ROD IS LOCATED  
 72" ABOVE THE BOTTOM OF THE ROD.

Figure 4-8. Blockage Sleeve Distribution Used for COBRA Calculation (Case 3)



THE NUMBERS IN RODS ARE SLEEVE LOCATIONS. FOR EXAMPLE,  
 (72'') - MAXIMUM STRAIN OF THE SLEEVE ON THE ROD IS LOCATED  
 72'' ABOVE THE BOTTOM OF THE ROD.

Figure 4-9. Blockage Sleeve Distribution Used for COBRA Calculation (Case 2)

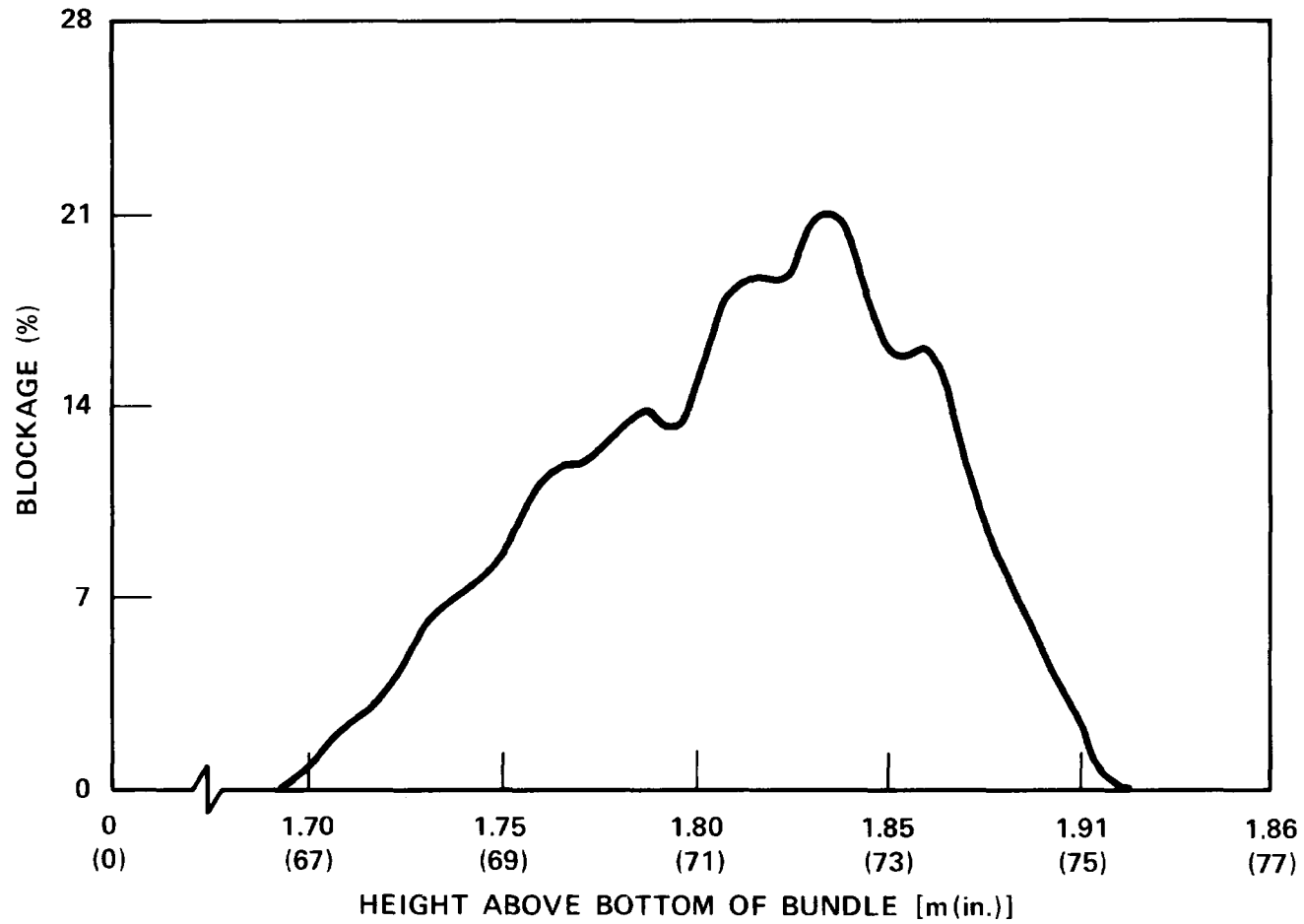

Figure 4-10. Average Blockage Distribution of 21-Rod Cluster (Concentric Sleeve With 32.6% strain)

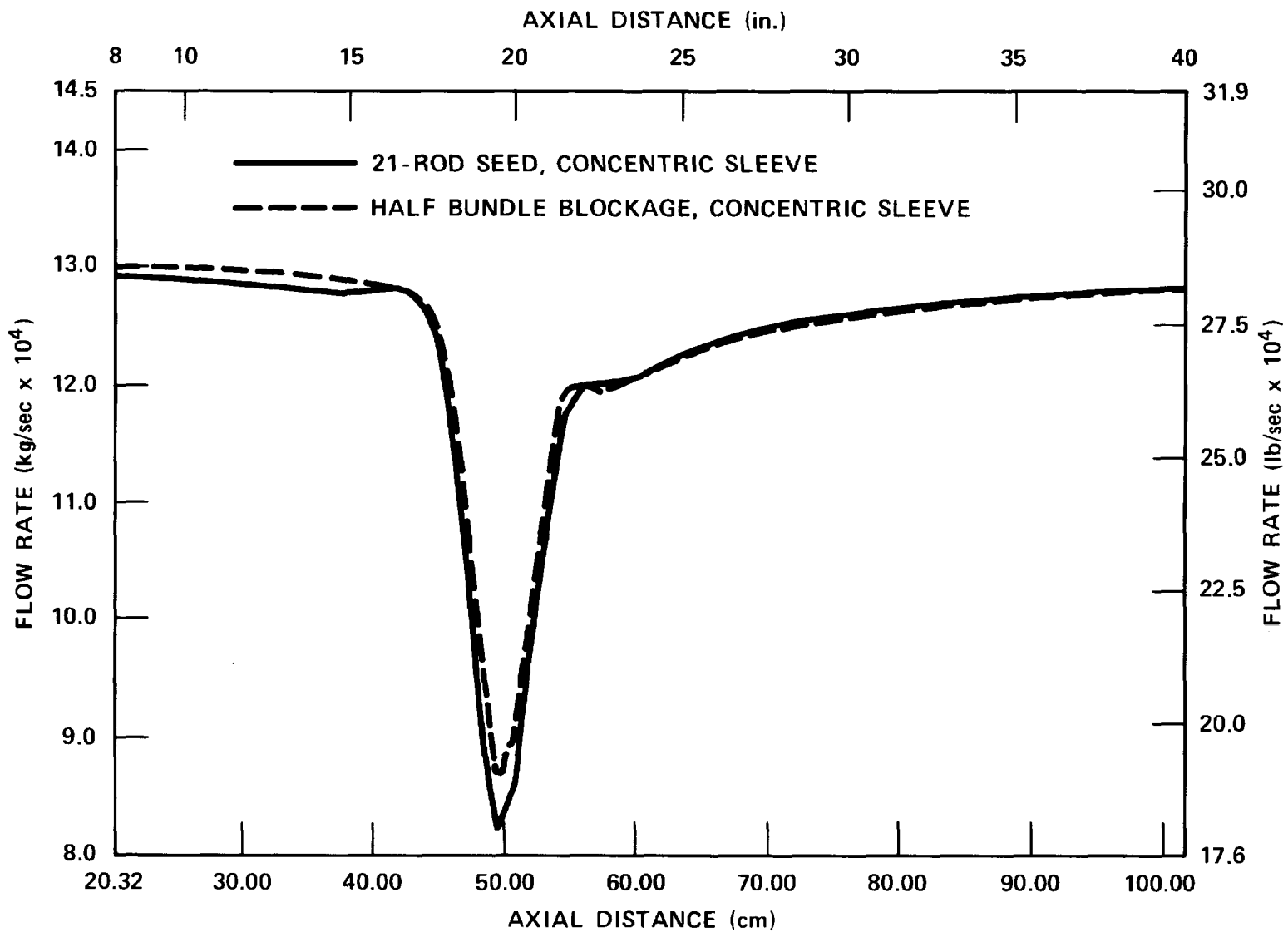

Figure 4-11. Flow Rates in Channel 50

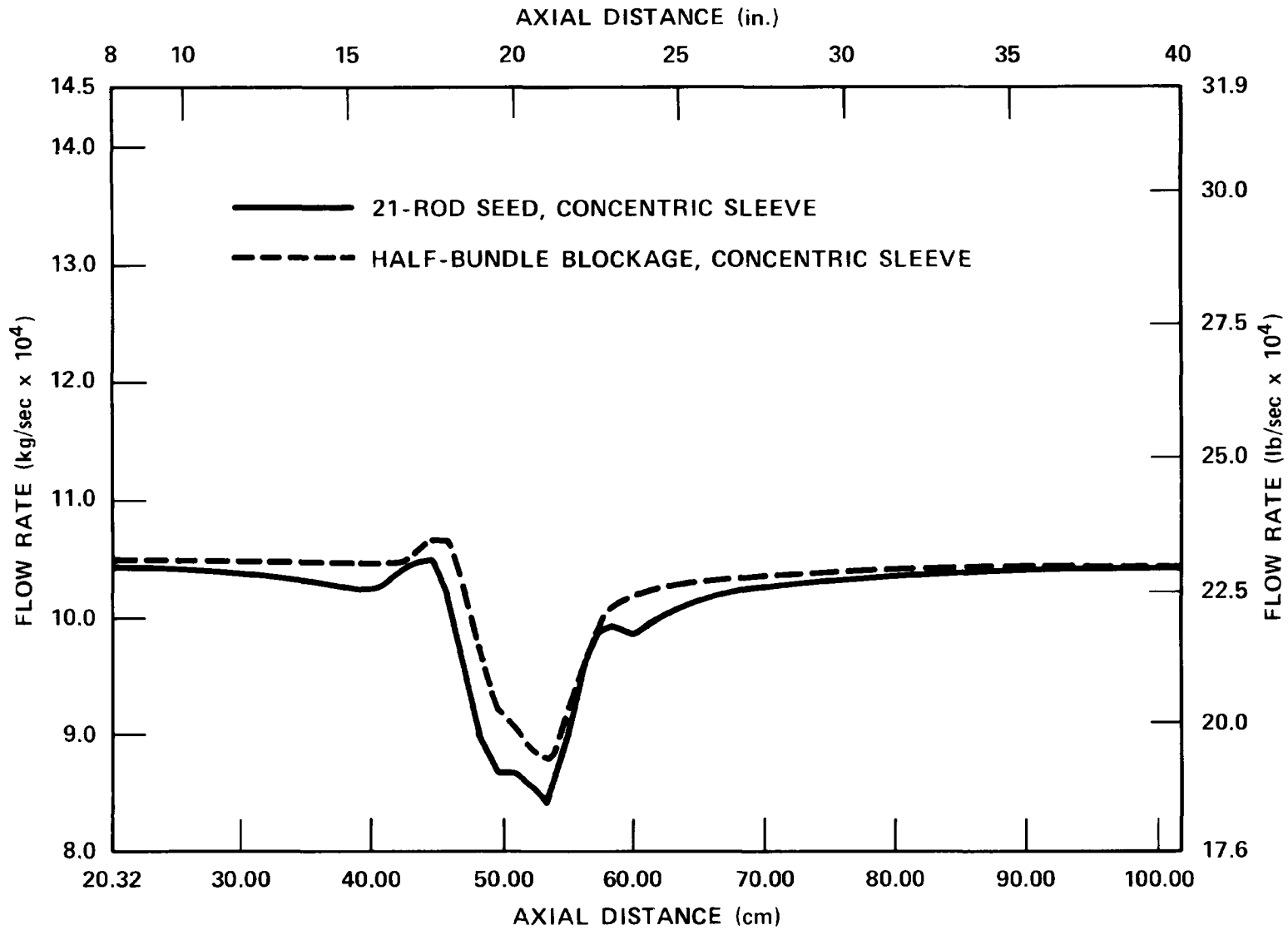

Figure 4-12. Flow Rates in Channel 51

4-22

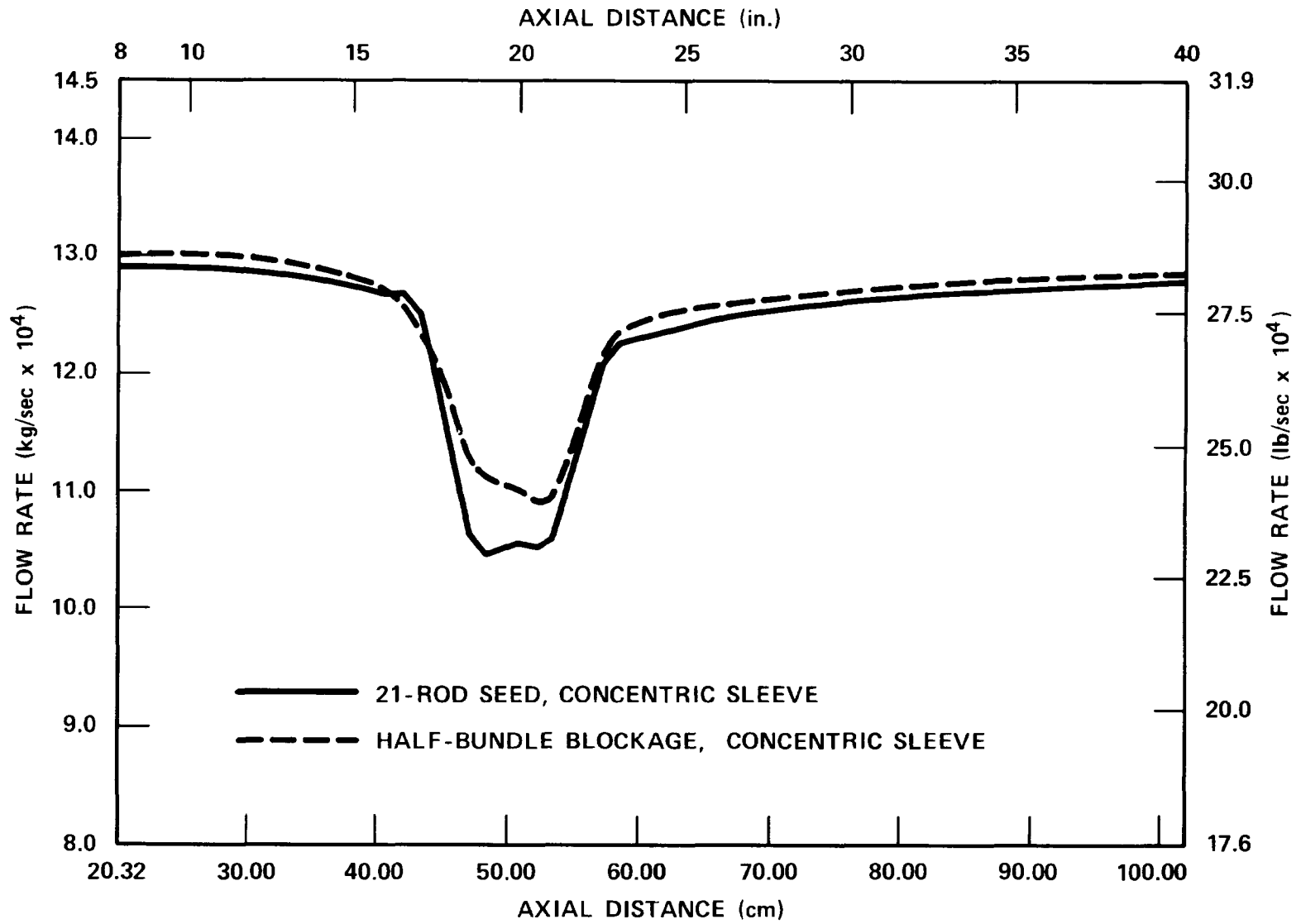

Figure 4-13. Flow Rates in Channel 63

16,389-5

TABLE 4-1

COMPARISONS OF PARTIAL BLOCKAGE-BYPASS CONFIGURATIONS

Case	Advantages	Disadvantages
1	<p>One-to-one heat transfer comparison between blocked and unblocked subchannels using bundle symmetry</p>	<p>Full-bundle COBRA simulation is not feasible</p> <p>Relatively limited bypass</p>
2	<p>Half-bundle COBRA simulation is feasible.</p> <p>Indirect one-to-one heat transfer comparison</p> <p>Allows determination of measurement uncertainty</p>	<p>Direct one-to-one heat transfer comparison is not possible.</p> <p>Limited bypass</p>
3	<p>Half-bundle COBRA simulation is feasible.</p> <p>Indirect one-to-one heat transfer comparison</p> <p>Allows determination of measurement uncertainty</p> <p>Large bypass</p> <p>Direct extension of 21-rod bundle test</p>	<p>Direct one-to-one heat transfer comparison is not possible.</p>

4-24

## SECTION 5

### INITIAL CONDITIONS AND RANGE OF CONDITIONS

Data requirements are determined by the task objectives, as presented in section 3 of this report, and by contract commitments, as presented in the work scope (appendix A). To meet task objectives, the heater rod bundle and test facility system instrumentation must be designed to provide sufficient data for calculating the following:

- Mass and energy balances around each loop component
  
- Global and local thermal-hydraulic conditions to develop models based on experimental data which can be used to interpret reflooding phenomena, and to identify flow and heat transfer regimes during reflood
  
- Heat transfer and mass entrainment data for formulating empirical correlations

Table 5-1 summarizes the basic data to be obtained and the instrumentation that will allow the above calculations to be made and hence achieve task objectives and task work scope. A more detailed description of bundle and system instrumentation is presented in section 7 of this report.

The resulting data and analysis from this task will be used to determine differences in flow blockage configurations. Parameter studies will subsequently be performed around the reference initial conditions for a worst case analyzed for a hypothetical loss-of-coolant accident of a Westinghouse standard 17 x 17 four-loop plant.<sup>(1)</sup>

The currently intended test reference initial conditions are listed in table 5-2. These specific conditions were derived from the following reference assumptions:

---

1. Johnson, W. J., et al., "Westinghouse ECCS Four-Loop Plant (17x17) Sensitivity Studies," WCAP-8566, July 1975.

TABLE 5-1

## BASIC DATA TO BE OBTAINED FOR 161-ROD BUNDLE FLOW BLOCKAGE TASK

Desired Data	Instrumentation	Location
Clad temperatures	Heater rod thermocouples	Inside surface of heater cladding at various axial and radial bundle elevations
Fluid temperatures	Fluid thermocouples and shielded steam probes	Test section plenums, in bundle at various elevations
Inlet flow rate	Turbine meter	Injection line
Inlet enthalpy	Fluid thermocouple and pressure transducer	Injection line and accumulator
System pressure	Pressure transducer	Test section upper plenum
System pressure drops	Differential pressure transducer	Across various loop components
Bundle exit steam mass rate	Orifice plate flowmeter	Exhaust line
Bundle exit liquid mass rate	Differential pressure transducer	Carryover tank and steam separator tank
Mass storage (void fraction distributions)	Differential pressure transducer	At each 0.3 m (1 ft) increment along the rod bundle heated length
System temperatures	Thermocouples	Accumulator, carryover tank, and steam separator piping
Rod bundle power	Wattmeter transducer	Input power lines

TABLE 5-1 (cont)

BASIC DATA TO BE OBTAINED FOR 161-ROD BUNDLE FLOW BLOCKAGE TASK

Desired Data	Instrumentation	Location
Housing temperatures	Wall thermocouple	Outside housing surface at various elevations
Flow regime	Photographs and movies	Bundle and upper plenum
Bundle exit steam temperature	Aspirating steam probe	Exhaust line, on either side of steam separator; and upper plenum

TABLE 5-2

REFERENCE AND RANGE OF TEST CONDITIONS FOR  
161-ROD BUNDLE FLOW BLOCKAGE TASK

Parameter	Initial Condition	Range of Conditions
Initial clad temperature	871 <sup>0</sup> C (1600 <sup>0</sup> F)	260 <sup>0</sup> C - 871 <sup>0</sup> C (500 <sup>0</sup> F - 1600 <sup>0</sup> F)
Peak power	2.30 kw/m (0.7 kw/ft)	0.89 - 2.3 kw/m (0.27 - 0.7 kw/ft)
Upper plenum pressure	0.28 MPa (40 psia)	0.14 - 0.41 MPa (20 - 60 psia)
Flooding rate:		
-- Constant	25.4 mm/sec (1 in./sec)	10.2 - 152 mm/sec (0.4 - 6 in./sec)
-- Variable in steps	-	152 to 20 mm/sec (6.0 to 0.8 in./sec)
Injection rate (gravity reflood - variable in steps	-	6.49 to 0.82 kg/sec (14.3 to 1.8 lb/sec)
Coolant $\Delta T$ subcooling	78 <sup>0</sup> C (140 <sup>0</sup> F)	3 <sup>0</sup> C-78 <sup>0</sup> C (5 <sup>0</sup> F-140 <sup>0</sup> F)

- The core hot assembly is simulated in terms of peak power and initial temperature at the time of core recovery, that is, the time when the emergency core cooling system water reaches the bottom of the core.
- Decay power is ANS + 20%, as specified by Appendix K.
- The initial rod clad temperature is primarily dependent on the full-power linear heating rate at the time of core recovery. For the period from 30 seconds to core recovery, typical results yield an initial clad temperature in the hot assembly of 871°C (1600°F).
- Coolant temperatures will be selected to maintain a constant subcooling to facilitate the determination of parametric effects.
- Coolant will be injected directly into the test section lower plenum for the forced flooding rate tests, and into the bottom of the downcomer for the gravity reflood scoping tests. Injection into the bottom of the downcomer is used for better test facility pressure control. (In previous gravity reflood experiments,<sup>(1)</sup> injection into the top of the simulated downcomer resulted in severe flow oscillation in the test section. The oscillation is believed to be caused by a condensation phenomenon associated with the specific facility designs. It was reduced by injection into the bottom of the downcomer.)
- Upper plenum pressure at the end of blowdown is approximately 0.14 MPa (20 psia) for an ice condenser plant, and about 0.28 MPa (40 psia) for a dry containment plant.
- Most tests will be performed with a uniform radial power profile, but some tests will be performed with radial power distribution which assumes a hot and cold channel power profile.
- The axial power shape built into the heater rod will be the modified cosine with a power peak-to-average ratio of 1.66 (figure 5-1).

---

1. Waring, J. P., and Hochreiter, L. E., "PWR FLECHT SET Phase B-1 Evaluation Report," WCAP-8583, August 1975.

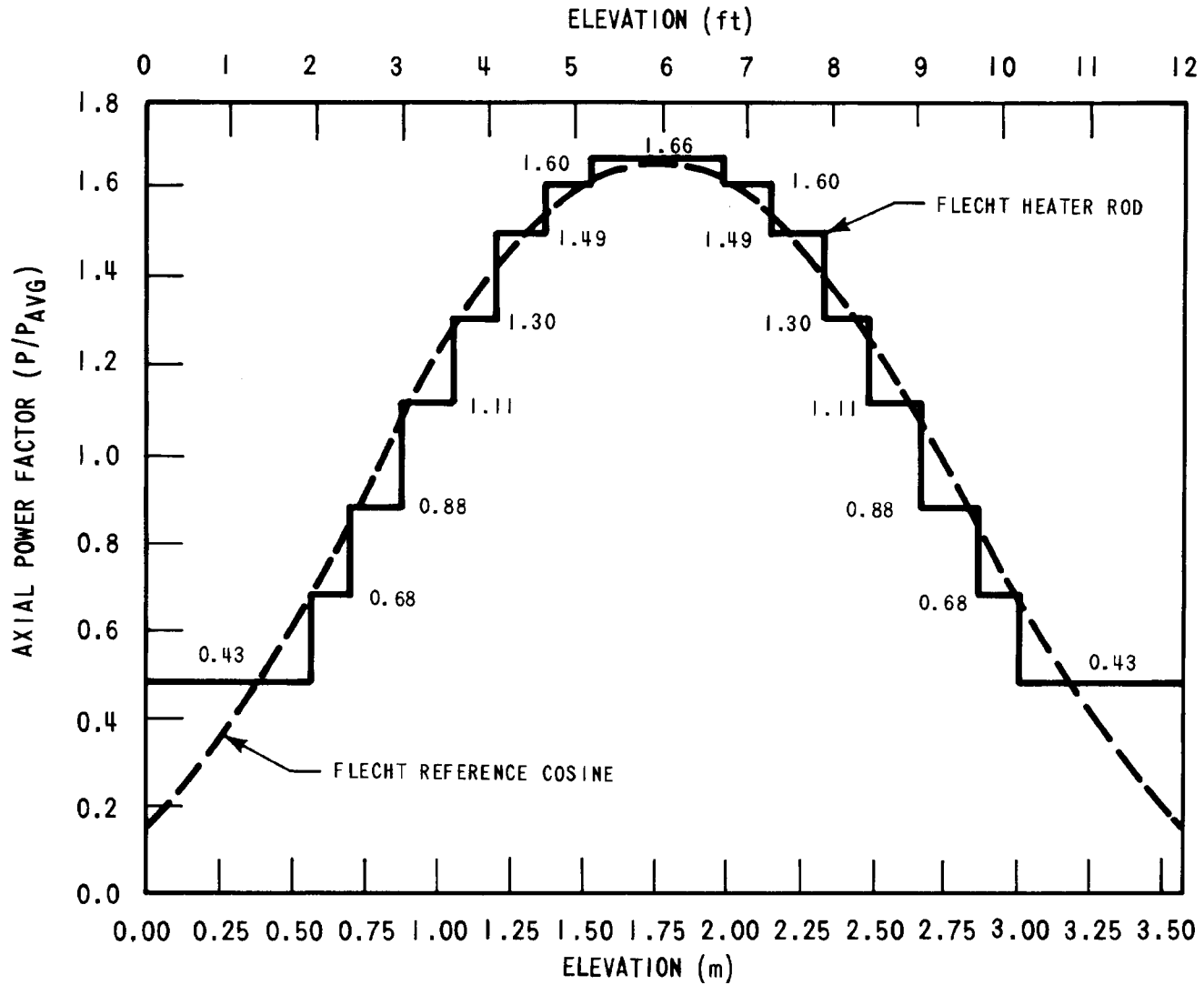

Figure 5-1. Cosine Axial Power Profile

The use of the 1.66 axial power profile will allow comparisons with the 161-rod unblocked and 21-rod bundle tests such that the bundle sizes are the primary difference among these tests.

The ranges of initial test conditions are listed in table 5-2. The specific tests to be conducted in this series are presented in section 8 of this report.



## SECTION 6

# TEST FACILITY DESCRIPTION

### 6-1. FACILITY DESIGN AND LAYOUT

A new facility will be designed and built for conducting the 161-rod bundle flow blockage tests, since the facility previously utilized for the unblocked bundle tests will be utilized in the systems effects tests. Facility drawings are presented in this section and in appendix B.

The test facility will be designed to the following basic requirements (figure 6-1):

- The facility will be capable of performing reflood heat transfer tests with a 161-rod bundle utilizing 0.950 cm (0.374 in.) OD heater rods (table 2-1).
- The facility will be capable of performing forced flooding and gravity reflood tests similar to those performed in the 21-rod bundle facility.<sup>(1)</sup>
- All loop components and piping downstream of the test section will be designed for 0.52 MPa (75 psia) and 343<sup>o</sup>C (650<sup>o</sup>F) service. The housing and upper plenum will be designed for 0.52 MPa (75 psia) and 816<sup>o</sup>C (1500<sup>o</sup>F) service. The test housing and plenums as well as all other components will be fabricated from stainless steel.
- The volumes of the upper and lower plenums, downcomer, crossover pipe, and steam separator tanks will be essentially the same as in the unblocked bundle facility.<sup>(2)</sup> The carryover tank volume will be increased to accommodate additional overflow capacity.

- 
1. Hochreiter, L. E., et al., "PWR FLECHT SEASET 21-Rod Bundle Flow Blockage Task: Task Plan Report," NRC/EPRI/Westinghouse-5, March 1980.
  2. Hochreiter, L. E., et al., "PWR FLECHT SEASET Unblocked Bundle, Forced and Gravity Reflood Task: Task Plan Report," NRC/EPRI/Westinghouse-3, March 1978.

-- The test section will be designed to facilitate disassembly for bundle changeovers.

The test facility will utilize existing silicon-controlled rectifier (SCR) power supplies and circuit breakers for bundle power supply, the computer front end for data acquisition, water supply tanks to supply flow, and the 21-rod facility electric boiler for steam heating. The remaining facility hardware and equipment will be new and will include the test section, test bundles, carryover vessel, entrainment separator, exhaust line piping, coolant injection system, and downcomer.

During forced reflood test operation, coolant flow from the 1.52 m<sup>3</sup> (400 gal) capacity water supply accumulators will enter the test section housing through a series of hand valves or automatically through a pneumatically operated control valve and a series of solenoid valves. Coolant flow will be measured by a turbine meter located in the injection line. Test section pressure will be established initially by a steam boiler connected to the upper plenum of the test section. During the experimental run, the boiler will be valved out of the system and pressure maintained by a pneumatically operated control valve located in the exhaust line. Liquid effluent leaving the test section will be separated in the upper plenum and collected in a close-coupled carryover tank. An entrainment separator located in the exhaust line will be used to separate any remaining entrained liquid in the vapor. Dry steam flow leaving the separator will be measured by an orifice meter before it is exhausted to the atmosphere. Additional system features include the following:

- Axial test section differential pressure (DP) cells installed every 0.30 m (12 in.) for accurate mass accumulation and void fraction measurements
- Two steam probes located in the test section outlet pipe
- A vee-ball control valve to control system pressure

The facility will be modified during the test series to conduct gravity reflood tests. The modifications consist of connecting a downcomer to the lower plenum, moving the injection line from the lower plenum to the bottom of the downcomer, venting the top

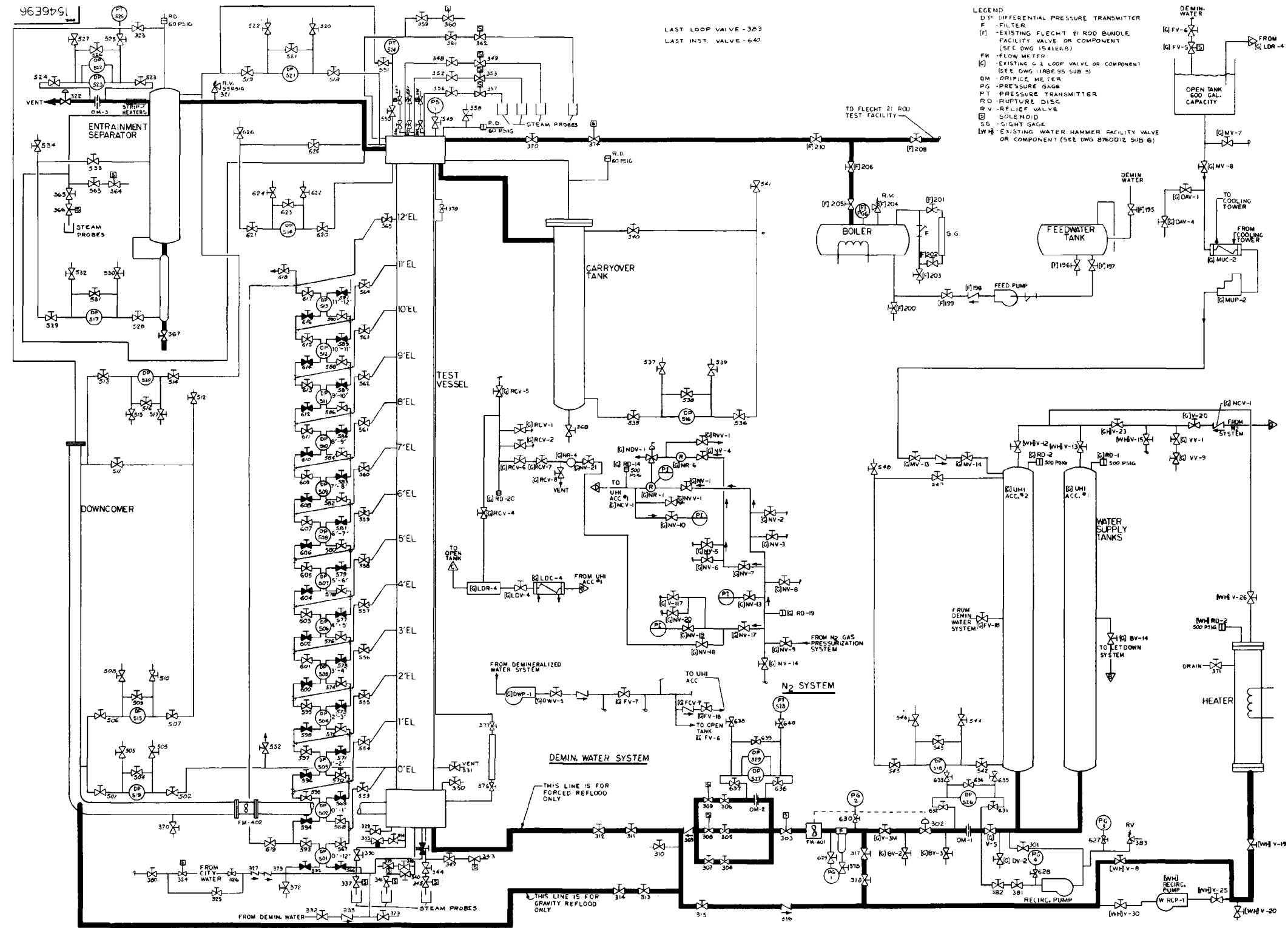

Figure 6-1. Forced and Gravity Reflood Configuration Flow Diagram



of the downcomer to the entrainment separator, and installing additional instrumentation and differential pressure cells. Reflood flow into the test section and any reverse flow out of the test section will be measured by a bidirectional turbo-probe located in the downcomer crossover leg.

## 6-2. FACILITY COMPONENT DESCRIPTION

The various components of the test facility are described in the following paragraphs.

### 6-3. Test Section

The low mass housing, together with the lower and upper plenums, constitutes the test section. With the exception of the stainless steel plenums and the number and location of nozzles, the test section is identical to that of the unblocked facility (figure 6-2).

The low mass housing shown in figure 6-3 is a cylindrical vessel of 193.7 mm (7.625 in.) ID by 5.08 mm (0.200 in.) wall thickness, constructed of 304 stainless steel rated for 0.52 MPa (60 psig) at 816<sup>o</sup>C (1500<sup>o</sup>F). The wall thickness, the minimum thickness allowed by Section I of the ASME Boiler and Pressure Vessel Code, was chosen so that the housing will absorb and hence release a minimum amount of heat as compared with the rod bundle. The inside diameter of the housing was made as close to the rod bundle outer dimensions as possible to minimize excess flow area. The excess flow area is further minimized by solid triangular fillers (figure 6-4). The housing has two commercially manufactured sight glasses located 180 degrees apart at the 0.9, 1.8, and 2.7 m (3, 6, and 9 ft) elevations; these will be used for viewing and photographic studies. The sight glass configuration allows both front and back lighting for photographic studies. The sight glasses will also have clamp-on heaters to raise the quartz temperature above saturation at the initiation of reflood, to approximately 260<sup>o</sup>C (500<sup>o</sup>F). This feature will help to prevent formation of a liquid film on the windows during a test run. The housing will also have differential pressure cell pressure taps located every 0.30 m (12 in.) to measure liquid level in the housing. To help eliminate buckling and thermal distortion, the section will be supported from the upper plenum to permit the housing to expand freely downwards. Lateral supports will be installed at four elevations to restrict the housing from bowing.

View ports will be added to the upper plenum for viewing and photographic studies. Provisions will also be made in the upper plenum to insert fluid thermocouples and endoscopes.

#### 6-4. Test Bundle

A cross section of the test bundle is shown in figure 6-4. The bundle comprises 161 heater rods (111 uninstrumented and 50 instrumented), 4 instrumented thimbles, 12 steam probe thimbles, and 8 solid triangular fillers. Details of the heater rods are shown in figure 6-5. The thermophysical properties of the heater rod materials are listed in table 6-1. The triangular fillers are split and pin-connected to one another between grids, and welded to the grids both to maintain the proper grid location and to accommodate thermal growth. The fillers will also help to reduce the amount of excess flow area in the housing. The excess flow area is 4.7 percent with the fillers and 9.3 percent without the fillers. Blockage sleeves will be installed on 38 heater rods in the bundle.

#### 6-5. Carryover Vessel

The function of the carryover vessel is to collect liquid which flows out of the bundle and is deentrained in the upper plenum. The vessel will be fabricated from stainless steel pipe and fittings. Its capacity will be increased over that of the unblocked facility vessel, which was undersized, to accommodate additional water carryover volume.

#### 6-6. Entrainment Separator

Located in the exhaust line, the steam separator is designed to remove any remaining water droplets leaving the upper plenum so that a meaningful single-phase flow measurement can be obtained by an orifice meter downstream from the separator. The vessel shell will be 0.30 m (12 in.) standard weight stainless steel pipe with a volume of 0.22 m<sup>3</sup> (7.8 ft<sup>3</sup>). The separator operates by utilizing centrifugal action to force the heavier moisture against the wall, where it drains to the bottom. The water is

BILL OF MATERIAL						
REV	QTY	PART NAME	QTY REQ'D	MATERIAL	UNIT	QTY
01		HOUSING	1	1444 E 97601		
02		UPPER PLENUM	1	1447 E 25601		
03		LOWER PLENUM	1	1447 E 29601		
04		UPPER EXTENSION	1	8764 D 56601		
05		LOWER EXTENSION	1	8764 D 55602		
06		25 UNK PAN SOC HD CAPSR	16	SST		
07		GASKET	2	8764 D 55606		
08		50 15 UNK 20 HEX NUT	32	SST		
09		GASKET	1	8764 D 55602		

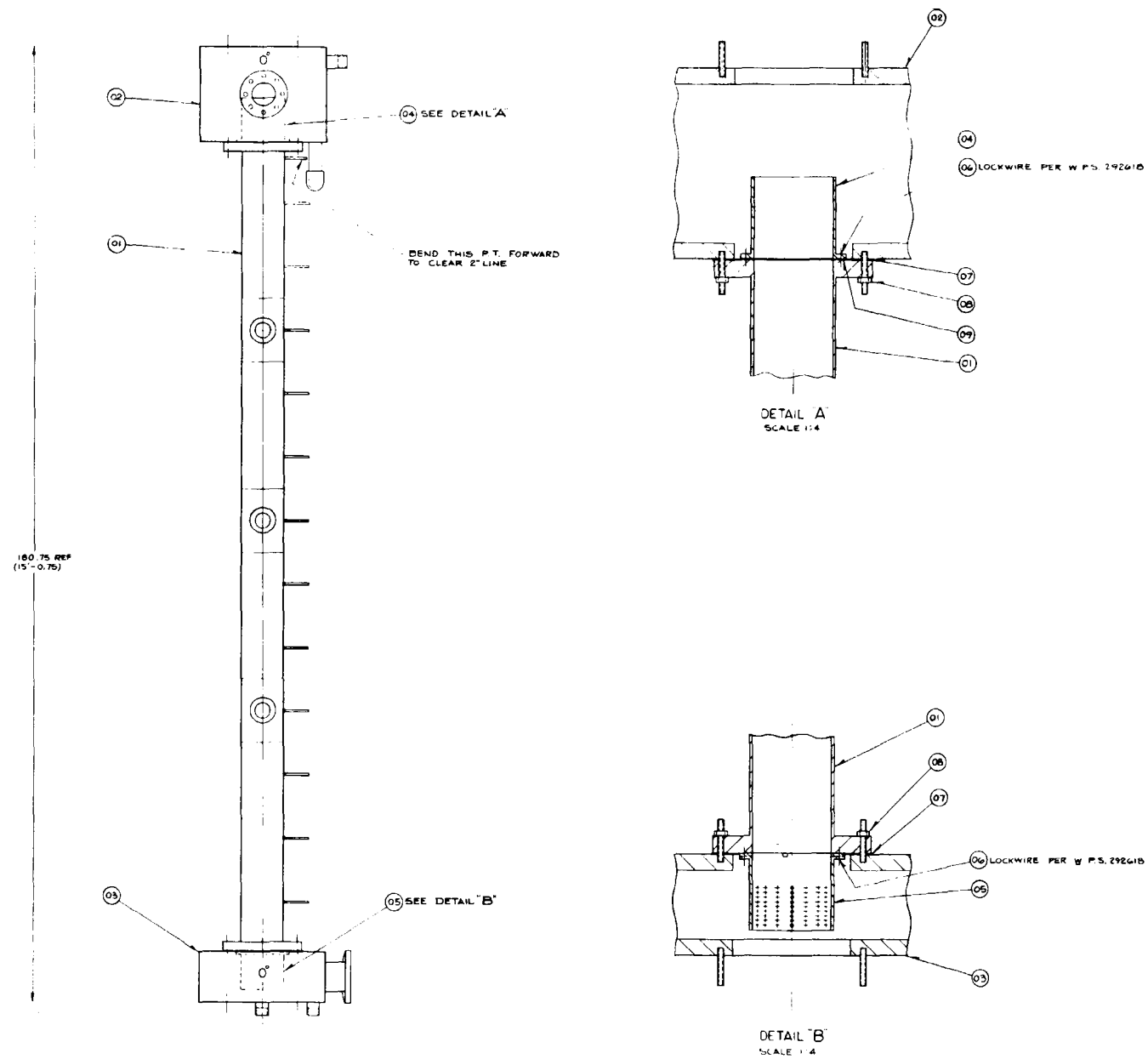

UNLESS OTHERWISE SPECIFIED THE FOLLOWING TOLERANCES APPLY

FINISHES: UNLESS OTHERWISE SPECIFIED, SURFACES SHALL BE: FRACTIONAL DIMENSIONS: UNLESS OTHERWISE SPECIFIED, DIMENSIONS SHALL BE TO THE NEAREST 0.0005 INCH. DECIMAL DIMENSIONS: UNLESS OTHERWISE SPECIFIED, DIMENSIONS SHALL BE TO THE NEAREST 0.0001 INCH. ANGLES: UNLESS OTHERWISE SPECIFIED, ANGLES SHALL BE TO THE NEAREST 5 MINUTES. HOLE POSITION: UNLESS OTHERWISE SPECIFIED, HOLE POSITION SHALL BE TO THE NEAREST 0.005 INCH. HOLE SIZE: UNLESS OTHERWISE SPECIFIED, HOLE SIZE SHALL BE TO THE NEAREST 0.0005 INCH. HOLE LOCATION: UNLESS OTHERWISE SPECIFIED, HOLE LOCATION SHALL BE TO THE NEAREST 0.005 INCH. HOLE DEPTH: UNLESS OTHERWISE SPECIFIED, HOLE DEPTH SHALL BE TO THE NEAREST 0.0005 INCH. HOLE TAPER: UNLESS OTHERWISE SPECIFIED, HOLE TAPER SHALL BE TO THE NEAREST 0.0005 INCH. HOLE CHAMFER: UNLESS OTHERWISE SPECIFIED, HOLE CHAMFER SHALL BE TO THE NEAREST 0.0005 INCH. HOLE DRILLING: UNLESS OTHERWISE SPECIFIED, HOLE DRILLING SHALL BE TO THE NEAREST 0.0005 INCH. HOLE REAMING: UNLESS OTHERWISE SPECIFIED, HOLE REAMING SHALL BE TO THE NEAREST 0.0005 INCH. HOLE POLISHING: UNLESS OTHERWISE SPECIFIED, HOLE POLISHING SHALL BE TO THE NEAREST 0.0005 INCH. HOLE FINISH: UNLESS OTHERWISE SPECIFIED, HOLE FINISH SHALL BE TO THE NEAREST 0.0005 INCH. HOLE TOLERANCE: UNLESS OTHERWISE SPECIFIED, HOLE TOLERANCE SHALL BE TO THE NEAREST 0.0005 INCH. HOLE LOCATION TOLERANCE: UNLESS OTHERWISE SPECIFIED, HOLE LOCATION TOLERANCE SHALL BE TO THE NEAREST 0.005 INCH. HOLE DEPTH TOLERANCE: UNLESS OTHERWISE SPECIFIED, HOLE DEPTH TOLERANCE SHALL BE TO THE NEAREST 0.0005 INCH. HOLE TAPER TOLERANCE: UNLESS OTHERWISE SPECIFIED, HOLE TAPER TOLERANCE SHALL BE TO THE NEAREST 0.0005 INCH. HOLE CHAMFER TOLERANCE: UNLESS OTHERWISE SPECIFIED, HOLE CHAMFER TOLERANCE SHALL BE TO THE NEAREST 0.0005 INCH. HOLE DRILLING TOLERANCE: UNLESS OTHERWISE SPECIFIED, HOLE DRILLING TOLERANCE SHALL BE TO THE NEAREST 0.0005 INCH. HOLE REAMING TOLERANCE: UNLESS OTHERWISE SPECIFIED, HOLE REAMING TOLERANCE SHALL BE TO THE NEAREST 0.0005 INCH. HOLE POLISHING TOLERANCE: UNLESS OTHERWISE SPECIFIED, HOLE POLISHING TOLERANCE SHALL BE TO THE NEAREST 0.0005 INCH. HOLE FINISH TOLERANCE: UNLESS OTHERWISE SPECIFIED, HOLE FINISH TOLERANCE SHALL BE TO THE NEAREST 0.0005 INCH. HOLE TOLERANCE: UNLESS OTHERWISE SPECIFIED, HOLE TOLERANCE SHALL BE TO THE NEAREST 0.0005 INCH. HOLE LOCATION TOLERANCE: UNLESS OTHERWISE SPECIFIED, HOLE LOCATION TOLERANCE SHALL BE TO THE NEAREST 0.005 INCH. HOLE DEPTH TOLERANCE: UNLESS OTHERWISE SPECIFIED, HOLE DEPTH TOLERANCE SHALL BE TO THE NEAREST 0.0005 INCH. HOLE TAPER TOLERANCE: UNLESS OTHERWISE SPECIFIED, HOLE TAPER TOLERANCE SHALL BE TO THE NEAREST 0.0005 INCH. HOLE CHAMFER TOLERANCE: UNLESS OTHERWISE SPECIFIED, HOLE CHAMFER TOLERANCE SHALL BE TO THE NEAREST 0.0005 INCH. HOLE DRILLING TOLERANCE: UNLESS OTHERWISE SPECIFIED, HOLE DRILLING TOLERANCE SHALL BE TO THE NEAREST 0.0005 INCH. HOLE REAMING TOLERANCE: UNLESS OTHERWISE SPECIFIED, HOLE REAMING TOLERANCE SHALL BE TO THE NEAREST 0.0005 INCH. HOLE POLISHING TOLERANCE: UNLESS OTHERWISE SPECIFIED, HOLE POLISHING TOLERANCE SHALL BE TO THE NEAREST 0.0005 INCH. HOLE FINISH TOLERANCE: UNLESS OTHERWISE SPECIFIED, HOLE FINISH TOLERANCE SHALL BE TO THE NEAREST 0.0005 INCH.

SEE PROCESS SPECIFICATION NO. CAP000128 FOR SUPPLEMENTARY MANUFACTURING INFORMATION

Figure 6-2. FLECHT SEASET 161-Rod Blocked Bundle Test Section Assembly



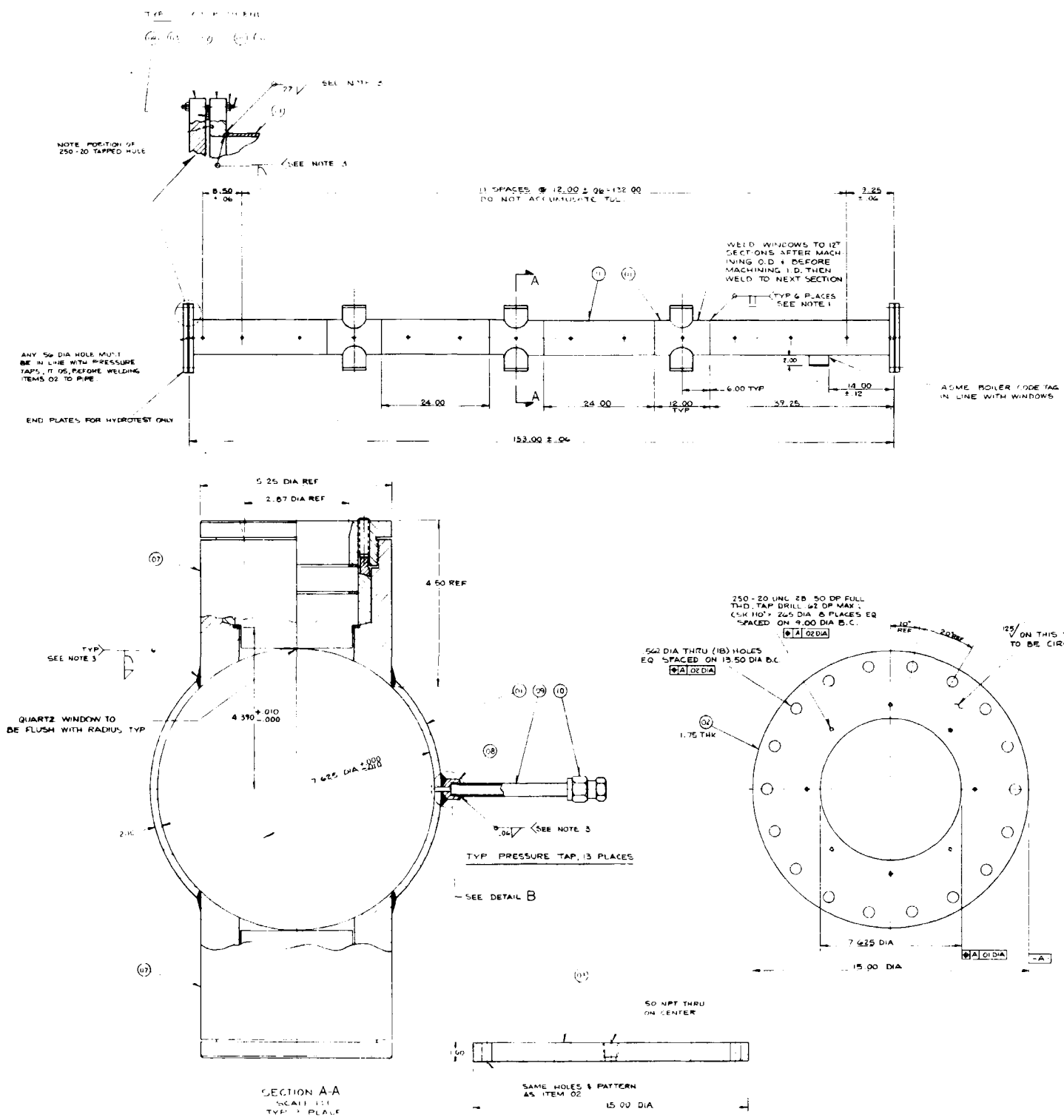

BILL OF MATERIAL					
NO	PART NAME	PART NO.	MATERIAL	QTY	UNIT
01	FLANGE		SA 312 TYPE 304	3	
02	FLANGE		SA 312 TYPE 304	2	
03	FLANGE		SA 312 TYPE 304	2	
04	FLANGE		SA 312 TYPE 304	2	
05	FLANGE		SA 312 TYPE 304	2	
06	FLANGE		SA 312 TYPE 304	2	
07	FLANGE		SA 312 TYPE 304	2	
08	FLANGE		SA 312 TYPE 304	2	
09	FLANGE		SA 312 TYPE 304	2	
10	FLANGE		SA 312 TYPE 304	2	
11	FLANGE		SA 312 TYPE 304	2	
12	FLANGE		SA 312 TYPE 304	2	
13	FLANGE		SA 312 TYPE 304	2	
14	FLANGE		SA 312 TYPE 304	2	
15	FLANGE		SA 312 TYPE 304	2	
16	FLANGE		SA 312 TYPE 304	2	
17	FLANGE		SA 312 TYPE 304	2	
18	FLANGE		SA 312 TYPE 304	2	
19	FLANGE		SA 312 TYPE 304	2	
20	FLANGE		SA 312 TYPE 304	2	
21	FLANGE		SA 312 TYPE 304	2	
22	FLANGE		SA 312 TYPE 304	2	
23	FLANGE		SA 312 TYPE 304	2	
24	FLANGE		SA 312 TYPE 304	2	
25	FLANGE		SA 312 TYPE 304	2	
26	FLANGE		SA 312 TYPE 304	2	
27	FLANGE		SA 312 TYPE 304	2	
28	FLANGE		SA 312 TYPE 304	2	
29	FLANGE		SA 312 TYPE 304	2	
30	FLANGE		SA 312 TYPE 304	2	
31	FLANGE		SA 312 TYPE 304	2	
32	FLANGE		SA 312 TYPE 304	2	
33	FLANGE		SA 312 TYPE 304	2	
34	FLANGE		SA 312 TYPE 304	2	
35	FLANGE		SA 312 TYPE 304	2	
36	FLANGE		SA 312 TYPE 304	2	
37	FLANGE		SA 312 TYPE 304	2	
38	FLANGE		SA 312 TYPE 304	2	
39	FLANGE		SA 312 TYPE 304	2	
40	FLANGE		SA 312 TYPE 304	2	
41	FLANGE		SA 312 TYPE 304	2	
42	FLANGE		SA 312 TYPE 304	2	
43	FLANGE		SA 312 TYPE 304	2	
44	FLANGE		SA 312 TYPE 304	2	
45	FLANGE		SA 312 TYPE 304	2	
46	FLANGE		SA 312 TYPE 304	2	
47	FLANGE		SA 312 TYPE 304	2	
48	FLANGE		SA 312 TYPE 304	2	
49	FLANGE		SA 312 TYPE 304	2	
50	FLANGE		SA 312 TYPE 304	2	

A-FLEXITALIC GASKET CO, CAMDEN, N.J.  
B-PRESSURE PRODUCTS CO, CHARLESTON, W.VA.  
C-PSH VALVE & FITTINGS CO, PSH, PA.

- NOTES:  
1-WELD PER W.P.W. PROC. SPEC. 292613-1.  
2-TO BE MADE PER ASME BOILER CODE SECTION I FOR 60 PSIG AT 1500° F. PEAK TEMP @ MID ELEVATION, 1000° F @ FLANGES, ITEM 02.  
3-WELD PER W.P.W. PROC. SPEC. 292613, LIQUID PENETRANT EXAM PER W.P.S. 595139, QUALITY LEVEL A.  
4-ITEMS 01 & 11 TO BE STRESS RELIEVED BEFORE FINAL MACHINING.  
5-HOUSING BODY TO BE STRAIGHT WITHIN .25 OVER ENTIRE LENGTH.

UNLESS OTHERWISE SPECIFIED THE FOLLOWING TOLERANCES APPLY:  
THREE PLACE DIMS ± .005 TWO PLACE DIMS ± .02  
DIMENSIONS ARE UNLESS OTHERWISE SPECIFIED TO THE NEAREST .001 INCH  
ALL DIMENSIONS ARE UNLESS OTHERWISE SPECIFIED TO THE NEAREST .001 INCH  
ALL DIMENSIONS ARE UNLESS OTHERWISE SPECIFIED TO THE NEAREST .001 INCH  
ALL DIMENSIONS ARE UNLESS OTHERWISE SPECIFIED TO THE NEAREST .001 INCH  
SEE PROCESS SPECIFICATION NO. CAPS98-26 FOR SUPPLEMENTARY MANUFACTURING INFORMATION

Figure 6-3. FLECHT SEASET 161-Rod Blocked Bundle Low Mass Housing



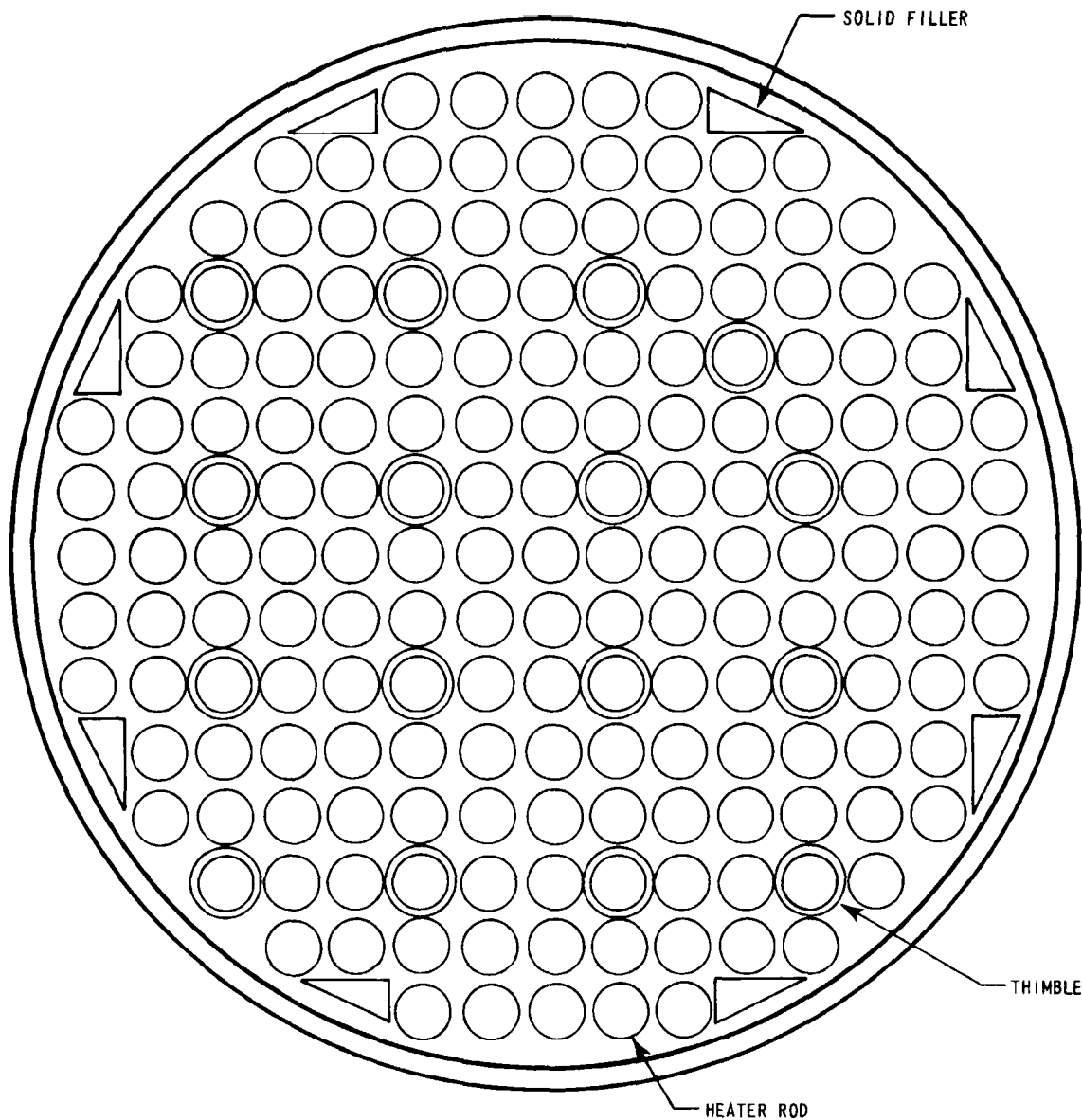

BUNDLE STATISTICS

Housing Inside Diameter	194.0 mm	7.625 in.
Housing Wall Thickness	5.08 mm	0.200 in.
Rod Diameter	9.50 mm	0.374 in.
Thimble Diameter	12.3 mm	0.484 in.
Rod Pitch	12.6 mm	0.496 in.
Cross-Sectional Flow Area	15476 mm <sup>2</sup>	23.989 in. <sup>2</sup>
Filler Dimensions	19.43 mm x 8.64 mm	0.765 in. x 0.340 in.
161 Heater Rods	-	-
16 Thimbles	-	-
8 Fillers	-	-

Figure 6-4. FLECHT SEASET 161-Rod Blocked Bundle Cross Section

TABLE 6-1

## THERMOPHYSICAL PROPERTIES OF HEATER ROD MATERIALS

Material	Density [ $\text{kg/m}^3(\text{lbm/ft}^3)$ ]	Specific Heat [ $\text{J/kg-}^\circ\text{C}(\text{Btu/lbm-}^\circ\text{F})$ ]	Thermal Conductivity [ $\text{W/m-}^\circ\text{C}(\text{Btu/hr-ft-}^\circ\text{F})$ ]
Kanthal	2898.70 (180.96)	$456.36 + 0.45674 T$ for $T \leq 649^\circ\text{C}$  $(0.109 + 0.000059 T)$ for $T \leq 1200^\circ\text{F}$  $4161.68 - 3.843 T$ for $649^\circ\text{C} < T < 871^\circ\text{C}$  $(0.994 - 0.00051 T)$ for $1200^\circ\text{F} < T < 1600^\circ\text{F}$  $664.86 + 0.0904 T$ for $T \geq 871^\circ\text{C}$  $(0.1588 + 0.000012 T)$ for $T \geq 1600^\circ\text{F}$	$16.784 + 0.0134 T$ ( $9.7 + 0.0043 T$ )
Boron nitride	2212.15 (138.1)	$2017.74 - 1396.26e^{-0.00245 T}$ [ $0.48193 - 0.333492e^{-0.0013611 T}$ ]	$25.571 - 0.00276 T$ ( $14.7778 - 0.0008889 T$ )
Stainless steel	8025.25 (501.0)	$443.8 + 0.2888 T$ for $T < 315^\circ\text{C}$  $(0.106 + 3.833 \times 10^{-5} T)$ for $T < 599.25^\circ\text{F}$  $484.4 + 0.1668 T$ for $T \geq 315^\circ\text{C}$  $(0.1157 + 2.2143 \times 10^{-5} T)$ for $T \geq 599.25^\circ\text{F}$	$14.535 + 0.01308 T$ ( $8.4 + 0.0042 T$ )





collected in a separator drain tank connected to the bottom of the separator. The drain tank shell will be a 10 cm (4 in.) standard weight stainless steel pipe with a volume of  $0.011 \text{ m}^3$  ( $0.4 \text{ ft}^3$ ).

#### 6-7. Exhaust Line Piping and Components

Test section effluent discharges to the atmosphere through the exhaust line piping. A 12 cm (5 in.) nozzle penetration on the upper plenum provides the attachment point for the exhaust line piping. Sandwiched between the two mating flanges is a 12 cm (0.5 in.) plate which serves as a structural attachment for an internal 7.6 cm (3 in.) baffle pipe assembly (figure 6-6). This baffle serves to improve the liquid carryout separation and minimize liquid entrainment into the exhaust vapor. After passing through the upper plenum baffle pipe, the vapor and remaining water droplets are separated in the entrainment separator and the exhaust vapor follows a 10 cm (4 in.) flanged orifice section before exhausting to the atmosphere through an air-operated backpressure control valve. Piping upstream of the orifice section will be heated with clamp-on strip heaters to assure single-phase steam flow measurement at the orifice. Steam probes will also be added at the exhaust line entrance and downstream of the entrainment separator.

Although the exhaust line components are similar to those used in the FLECHT SEASET unblocked facility, the piping size and arrangement will be changed to ensure adequate flow capacity and avoid restraints imposed by the new facility location.

#### 6-8. Coolant Injection System

The coolant injection system provides reflood water to quench the rod bundle during testing. In brief, coolant injection water is supplied by two  $0.757 \text{ m}^3$  (200 gal) water supply vessels through a flowmeter and a series of valves. Nitrogen overpressure on the water supply tanks provides the necessary driving head to attain the required injection rates. A recirculation pump and immersion heater vessel are used to bring the water and injection piping to the uniform specified test temperature prior to testing. The two water supply tanks, immersion heater vessel, and pump are existing components; piping from these components will be modified to suit facility requirements.

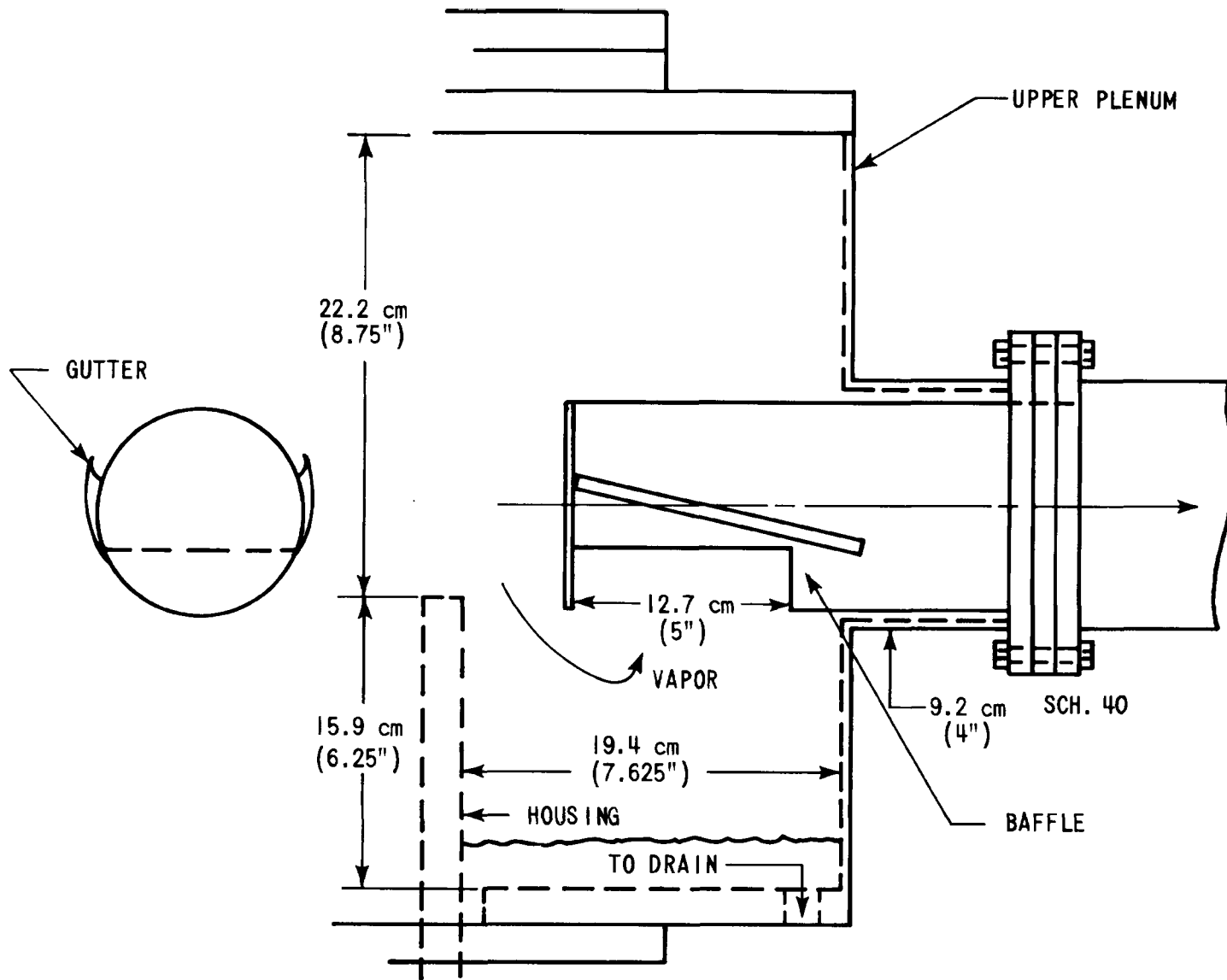

Figure 6-6. FLECHT SEASET Upper Plenum Baffle

During testing, constant or stepped injection flow is accomplished by the proper sequencing of solenoid valves, which are located in a piping manifold arrangement. Programmed flow to the test section is controlled by means of an air-operated valve, which operates from a demand signal from the computer with feedback from the turbine flowmeter.

Two turbine meters are used for flow measurement, one of range  $3.8 \times 10^{-5}$  to  $3.8 \times 10^{-3}$  m<sup>3</sup>/sec (0.6 to 60 gal/min) for forced flooding tests, and one of range  $9.5 \times 10^{-5}$  to  $9.5 \times 10^{-3}$  m<sup>3</sup>/sec (1.5 to 150 gal/min) for gravity reflood tests. In addition, a  $1.14 \times 10^{-2}$  m<sup>3</sup>/sec (180 gal/min) bidirectional turbo-probe will be installed in the downcomer crossover leg during gravity reflood tests to measure flow into the test section and any reverse flow from the test section to the downcomer.

#### 6-9. Downcomer and Crossover Leg

The downcomer and crossover leg will be connected to the test section lower plenum for gravity reflood tests. The downcomer and crossover leg will be fabricated from 12 cm (5 in.) stainless steel pipe or tubing with a 90-degree-long radius elbow, a specially designed spool piece for insertion of a turbo-probe flowmeter, and a flexible rubber expansion joint. The expansion joint connects the crossover leg to the lower plenum and allows for thermal growth of the test section. The horizontal run of the downcomer, called the crossover leg, is 2.3 m (7.5 ft) long and the vertical run is approximately 6.1 m (20 ft). A 3.8 cm (1.5 in.) nozzle located in the elbow of the downcomer will be used to inject the coolant water from the water supply system. The downcomer is shown schematically in figure 6-1.

#### 6-10. Heatup Boiler

The facility boiler is used for heating and pressurizing the facility components for forced and gravity reflood tests. Commercially available with its own automatic controls, it utilizes electric immersion heater elements to provide its rated  $1.57 \times 10^{-3}$  kg/sec (125 lb/hr) at 100°C (212°F) steaming capacity. The same unit is used for the FLECHT SEASET 21-rod test facility.

## 6-11. FACILITY OPERATION

The facility operation for forced reflood testing will be similar to the detailed procedures presented in WCAP-9108.<sup>(1)</sup> The following general procedure will be used to conduct a typical reflood test:

- (1) Fill accumulator with water and heat to desired coolant temperature [ $53^{\circ}\text{C}$  ( $127^{\circ}\text{F}$ ) nominal].
- (2) Turn on heatup boiler and bring the pressure up to 0.62 MPa (75 psig) nominal gage pressure.
- (3) Heat the carryover vessel, entrainment separator, separator drain tank, test section plenum, and test section outlet piping (located before the entrainment separator) while they are empty to slightly above the saturation temperature corresponding to the test run pressure. The exhaust line between the separator and exhaust orifice is heated to  $260^{\circ}\text{C}$  ( $500^{\circ}\text{F}$ ) nominal; the test section lower plenum is heated to the temperature of the coolant in the accumulator.
- (4) Pressurize the test section, carryover vessel, and exhaust line components to the specified test run pressure by valving in the boiler and setting the exhaust line control valve to the specified pressure.
- (5) Scan all instrumentation channels by the computer to check for defective instrumentation. The differential pressure and static pressure cell zero readings are taken and entered into the computer calibration file. These zero readings are compared with the component calibration zero reading. The straight-line conversion to engineering units is changed to the new zero when the raw data are converted to engineering units. This zero shift process accounts for errors due to transducer zero shifts and compensates for transducer reference leg levels, enabling the engineering units to start with an empty reading.

---

1. Rosal, E. R. et al., "FLECHT Low Flooding Rate Skewed Test Series Data Report," WCAP-9108, May 1977.

- (6) Apply power to the test bundle and allow rods to heat up. When the temperature in any two designated bundle thermocouples reaches the desired test flood temperature  $871^{\circ}\text{C}$  ( $1600^{\circ}\text{F}$ ), the computer automatically indicates flood and controls power decay. The exhaust control valve regulates the system pressure at the preset value by releasing steam to the atmosphere. The thimble tube steam probes are vented until rod temperature reaches  $648^{\circ}\text{C}$  ( $1200^{\circ}\text{F}$ ) and subsequently closed until rod temperature reaches  $871^{\circ}\text{C}$  ( $1600^{\circ}\text{F}$ ), to maintain system pressure. The system pressure is maintained by the heatup boiler, which has a capacity of  $1.57 \times 10^{-2}$  kg/sec (125 lb/hr).
- (7) Ascertain that all designated rods have quenched (indicated by the computer printout of bundle quench).
- (8) Cut power from heaters, terminate coolant injection, and depressurize the entire system.
- (9) Drain and weigh water from all components.

During the test series, the facility will be modified to conduct gravity reflood tests. The same procedure will be used to conduct these tests with the following exception: after flood is initiated, the flooding rate will be adjusted if necessary to assure that the level in the downcomer does not exceed the 4.88 m (192 in.) elevation.

This procedure, consistent with that used in the FLECHT unblocked facility, is necessary to avoid condensation caused by overflow and its resultant adverse effects on system pressure stability (see section 5).

6-20

## SECTION 7

# TEST FACILITY INSTRUMENTATION

### 7-1. GENERAL

The data recorded in this task will consist of temperature, power, flow, fluid level, and static pressure. The temperature data will be measured by type K (Chromel-Alumel) thermocouples using 66°C (150°F) reference junctions. The thermocouple locations are divided into two groups: test section bundle and loop. Bundle thermocouples consist of heater rod thermocouples, steam probes, and fluid thermocouples. The heater rod thermocouples will be monitored by the Computer Data Acquisition System (CDAS) for temperature at time of flood, overtemperature, and bundle quench temperature. The loop thermocouples measure fluid, vessel wall, and piping wall temperature.

Power input to the bundle heater rods will be measured by Hall-effect watt transducers. These watt transducers produce a direct current electrical output proportional to the power input. The voltage and current input to the watt transducer is scaled down by transformers so that the range of the watt transducer matches the bundle power. The scaling factor of the transformers will be accounted for when the raw data (millivolts) are converted to engineering units.

Injection flow will be measured by two turbine meters: one for forced flooding tests and one for gravity reflood tests. Gravity feed flow into or out of the bundle will be measured by a bidirectional turbo-probe located in the crossover leg. The turbine meter will be connected to a preamplifier and flow rate monitor for conversion of turbine blade pulses into flow rate in engineering units. The turbine meter flow rate monitor analog signal is proportional to the speed and direction of flow in the downcomer crossover leg. Calibration of the turbine meter by the manufacturer provides for data conversion to volumetric flows for the turbine meter analog signal.

The system pressure measurements will be both static and differential. The pressure transducers will be balanced bridge strain gage devices. The differential pressure readings will measure level in the vessels and the bundle and pressure drops across selected horizontal pipes.

Standard thermocouple calibration table entries and the corresponding coefficients will be used to compute the temperature value. All other channel calibration files will be straight-line interpolations of calibration data. The slope intercept and zero for the least-squares fit of a straight line to the equipment calibration data are computed for each channel and entered into its calibration file. The software uses this straight-line formula to convert millivolts to engineering units. Figure 7-1 presents a schematic diagram of the computer hardware interface.

The test instrumentation plan is presented in appendix C.

## 7-2. BUNDLE INSTRUMENTATION

The bundle instrumentation consists of heater rod thermocouples, thimble tube thermocouples, thimble tube and subchannel steam probes, differential pressure cells, power measurements, and plenum fluid measurements.

The exact location of the heater rod thermocouples and subchannel steam probes in the blockage zone of 1.51 m (62 in.) to 2.10 m (83 in.) cannot be specified until the blockage sleeve has been determined after the fifth test series in the 21-rod bundle task.<sup>(1)</sup> The length of the blockage sleeve, which could be from approximately 6 to 18 rod diameters, affects the placement of the heater rod thermocouples, since it is desired to minimize the number of heater rod thermocouples which are beneath the blockage sleeve.

## 7-3. Heater Rod Thermocouples

Fifty of the 161 heater rods in the large blocked bundle are instrumented with eight thermocouples each, for a total of 400 thermocouples. These 400 thermocouples

---

1. Hochreiter, L. E., et al., "PWR FLECHT SEASET 21-Rod Bundle Flow Blockage Task: Task Plan Report," NRC/EPRI/Westinghouse-5, March 1980.

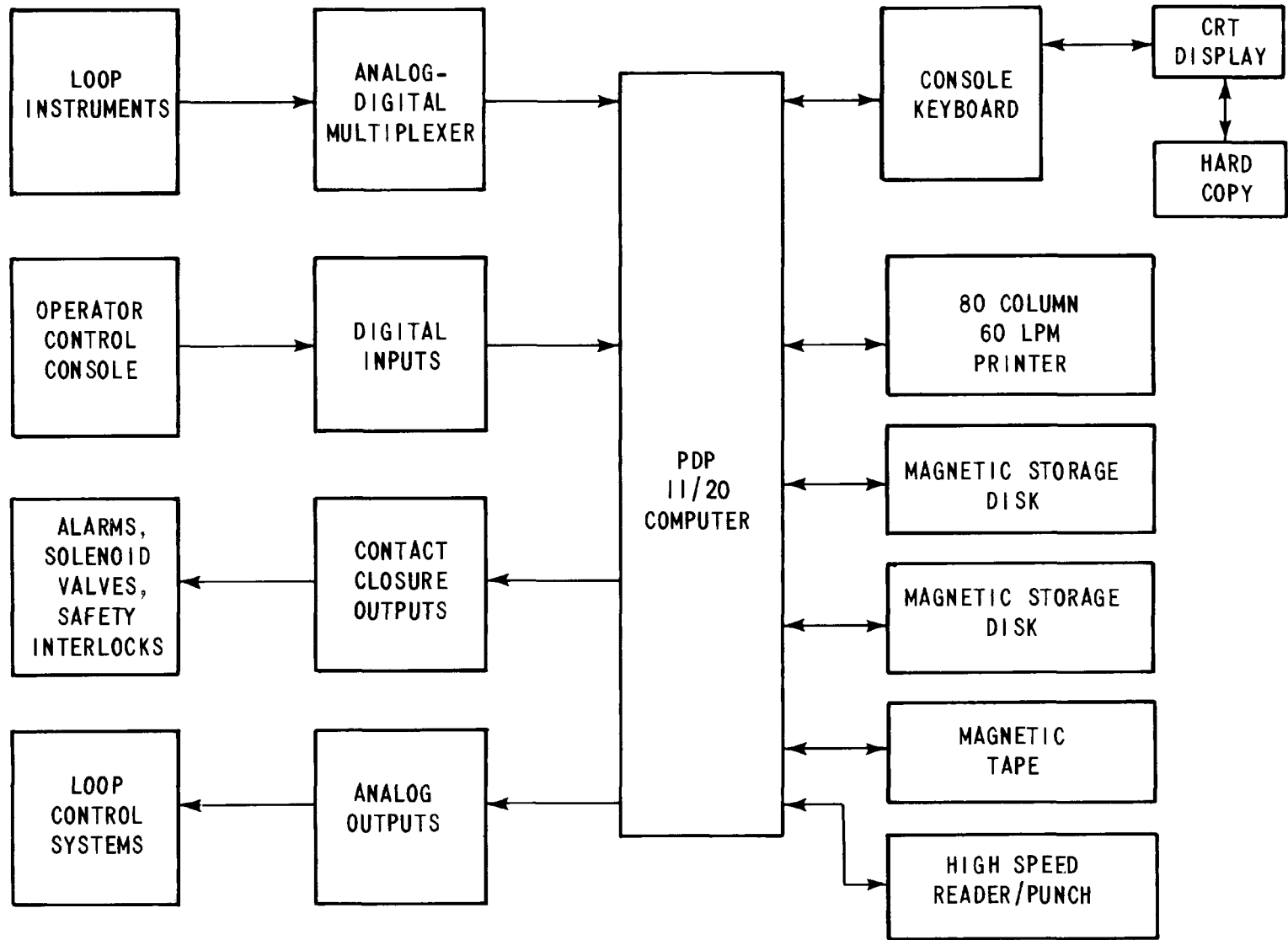

Figure 7-1. FLECHT SEASET Computer Hardware Interface (161-Rod Bundle)

will all be connected to the Computer Data Acquisition System. The placement of the heater rod thermocouples is based on the following:

- Maximizing direct comparisons with data from the 21-rod bundle and the 161-rod unblocked bundle
- Achieving a radial distribution such that both the flow blockage region and flow bypass region are adequately instrumented
- Location of the blockage sleeves as determined after the fifth test series of the 21-rod bundle task
- Achieving an axial distribution similar to that in the 21-rod bundle and 161-rod unblocked bundle
- Achieving an azimuthal orientation such that heater rod thermocouples are directed toward the subchannel instead of toward an adjacent heater rod
- Achieving a sufficient number of thermocouples upstream and downstream of the blockage zone to determine axial effect of blockage sleeves

Although the instrumentation in the blockage zone cannot be accurately specified until after the fifth test series of the 21-rod bundle task, the radial distribution of instrumented heater rods can be specified, as well as the heater rod instrumentation outside the blockage zone of 0.30 to 1.52 m (12 to 60 in.) and 2.13 to 3.51 m (84 to 138 in). The 50 heater rods to be instrumented in the 161-rod blocked bundle are shown in figure 7-2. These locations were instrumented based on the unblocked bundle instrumented locations and the 21-rod bundle island concept as previously discussed (paragraph 4-6). The large bundle will be blocked by distributing two 21-rod bundle islands in the center of the bundle, with each island having exactly the same blockage distribution as the 21-rod bundle. Each bundle built will have two islands blocking 38 heater rods located toward the center of the bundle, as shown in figure 7-3. The 50 instrumented heater rods were placed radially across the bundle so that the effect of both flow blockage and flow bypass could be evaluated. There are 23 instrumented rods within the two center 21-rod bundle islands, and 27 instrumented rods distributed azimuthally outside the

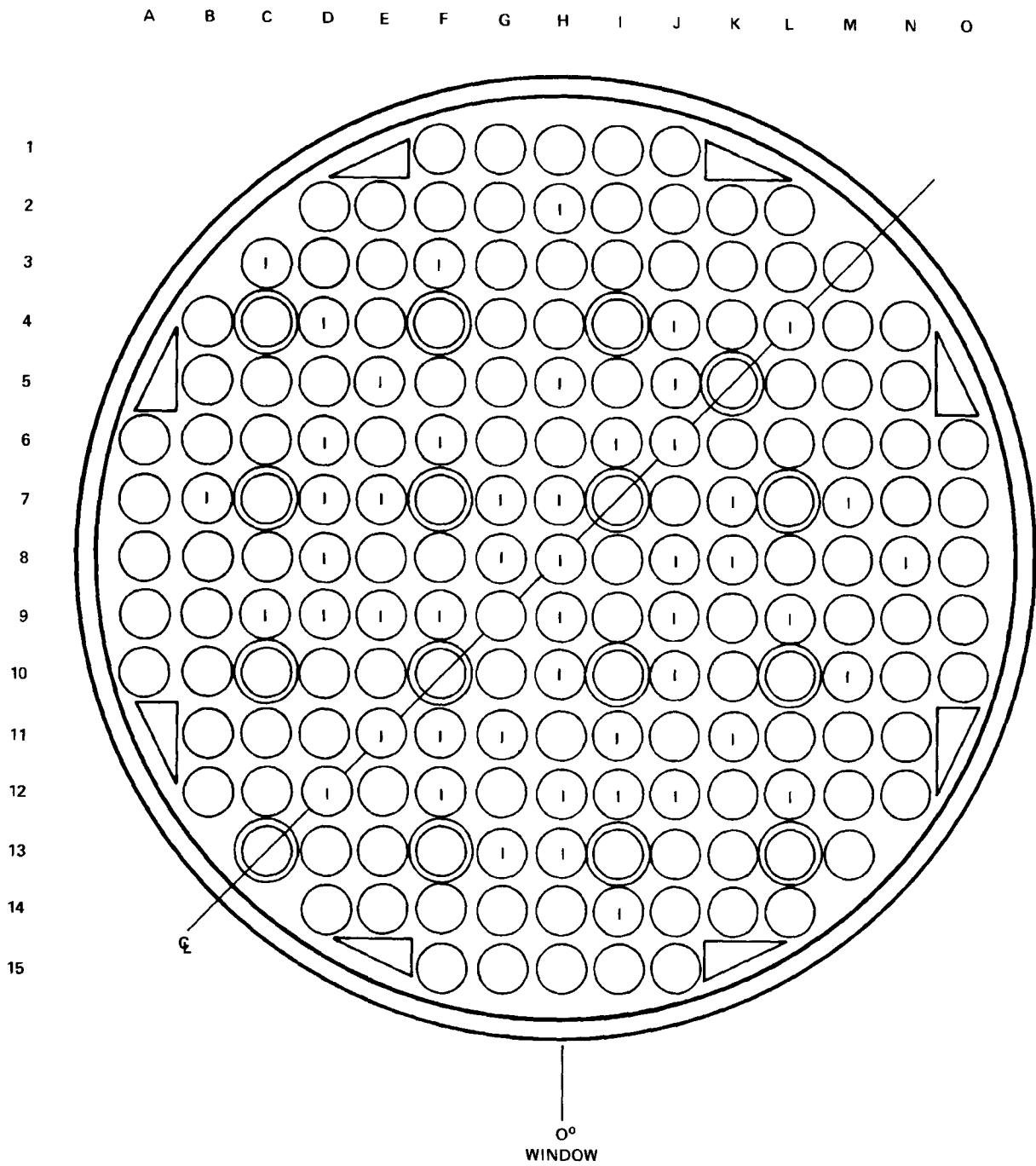

Figure 7-2. Instrumented Heater Rod Locations

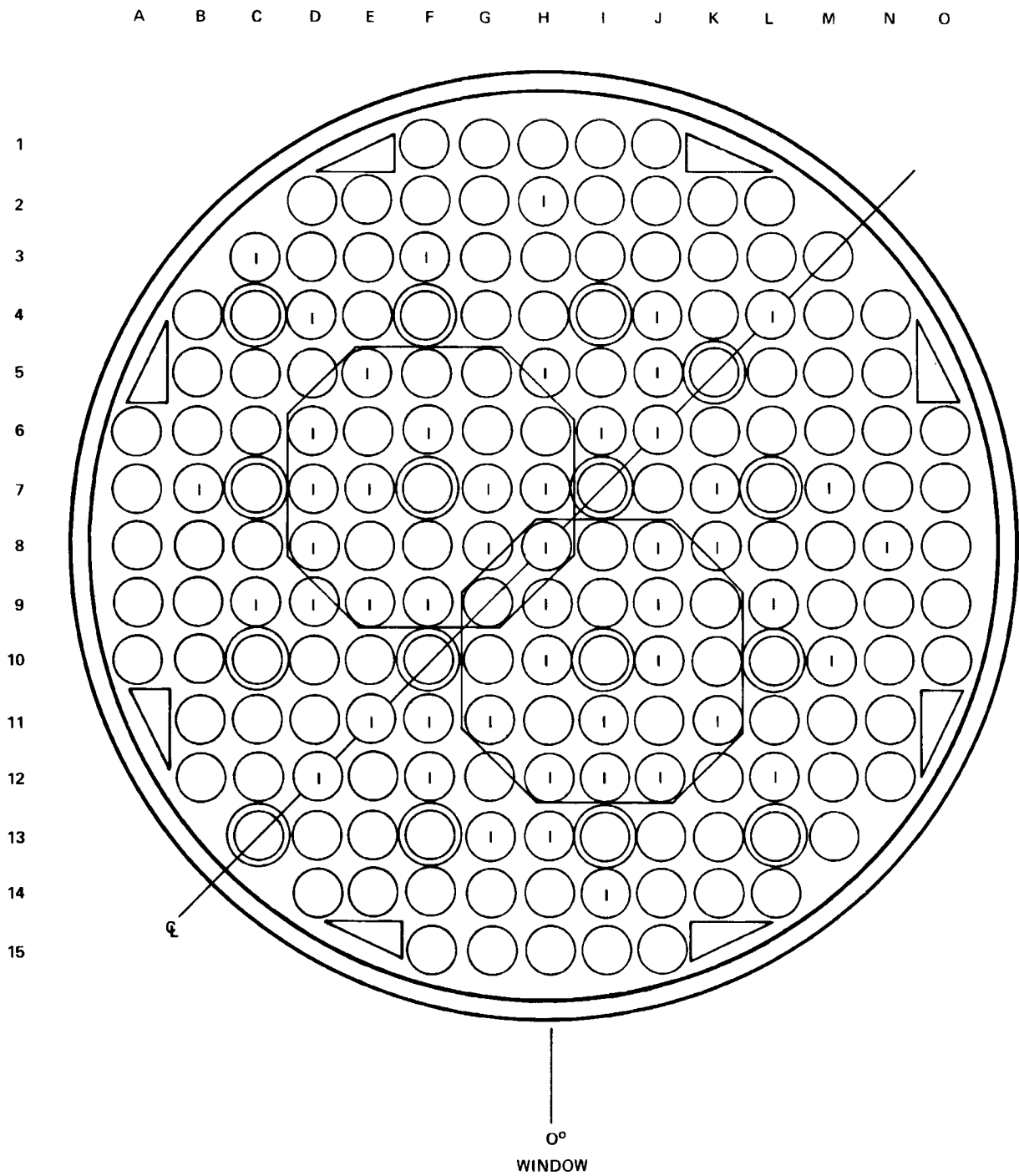

Figure 7-3. Instrumented Heater Rod Locations With Respect to Blockage Islands

two center islands. With respect to the line of symmetry, the 23 instrumented rods in the two center islands comprise 16 symmetrically instrumented locations, 6 nonsymmetrically instrumented locations, and 1 instrumented location common to both islands. The 27 instrumented rods outside the two center islands comprise 12 symmetrically instrumented locations, 11 nonsymmetrically instrumented locations, and 4 instrumented locations on the line of symmetry.

Of the 50 instrumented rod locations, 34 locations were selected based on the availability of unblocked bundle instrumentation and compatibility with 21-rod bundle instrumentation. These 34 rods have been initially assigned axial instrumentation the same as that in the unblocked bundle and the 21-rod bundle. The heater rod instrumentation includes heater rod groups 2, 4, and 5 from the unblocked bundle<sup>(1)</sup> and groups 4b and 14 from the 21-rod bundle.<sup>(2)</sup> The axial thermocouple distribution for each of these heater rod groups is shown in table 7-1. Since all these heater rod groups have some instrumentation (from one to four thermocouples) in the blockage zone of 1.57 to 2.11 m (62 to 83 in.), there may have to be modifications to these groups, pending determination of sleeve length and locations. These 34 instrumented rods provide varying degrees of comparison to both the unblocked bundle and the 21-rod bundle. As shown in figure 7-4, the rods denoted with a group number in a full circle provide only a fair data comparison with the unblocked bundle data; the rods denoted with a group number in the top half of a semicircle provide a good data comparison with the unblocked bundle data. The rods denoted with a group number in the bottom half of a semicircle provide data comparison with the 21-rod bundle. The remaining 16 instrumented rods (denoted by an I) will be instrumented dependent on the blockage sleeve distribution; they were placed radially across the bundle not only to provide potential data comparisons with the unblocked and 21-rod bundles, but also to fill instrumentation voids. The axial distribution of thermocouples for the I rods will be primarily concentrated in the blockage zone of 1.57 to 2.11 m (62 to 83 in.) and immediately upstream and downstream of the blockage zone.

- 
1. Hochreiter, L. E., et al., "PWR FLECHT SEASET Unblocked Bundle, Forced and Gravity Reflood Task: Task Plan Report," NRC/EPRI/Westinghouse-3, March 1978.
  2. Hochreiter, L. E., et al., "PWR FLECHT SEASET 21-Rod Bundle Flow Blockage Task: Task Plan Report," NRC/EPRI/Westinghouse-5, March 1980.

TABLE 7-1

AXIAL THERMOCOUPLE DISTRIBUTION

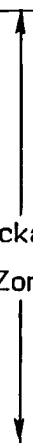
Elevation [m(in.)]	Heater Rod Group					
	2	4	4b	5	14	I
0.30 (12)		X	X			
0.61 (24)				X		
0.99 (39)		X	X			
1.22 (48)				X		
1.52 (60)		X	X			
1.70 (67)		X	X			 Blockage Zone
1.78 (70)						
1.80 (71)					X	
1.83 (72)	X			X		
1.88 (74)	X				X	
1.91 (75.25)					X	
1.93 (76)	X		X			
1.96 (77)					X	
1.98 (78)	X		X	X		
2.13 (84)	X	X				
2.29 (90)	X	X			X	
2.44 (96)	X			X		
2.64 (104)				X	X	
2.82 (111)	X	X	X			
3.05 (120)				X	X	
3.35 (132)		X	X			
3.50 (138)				X	X	

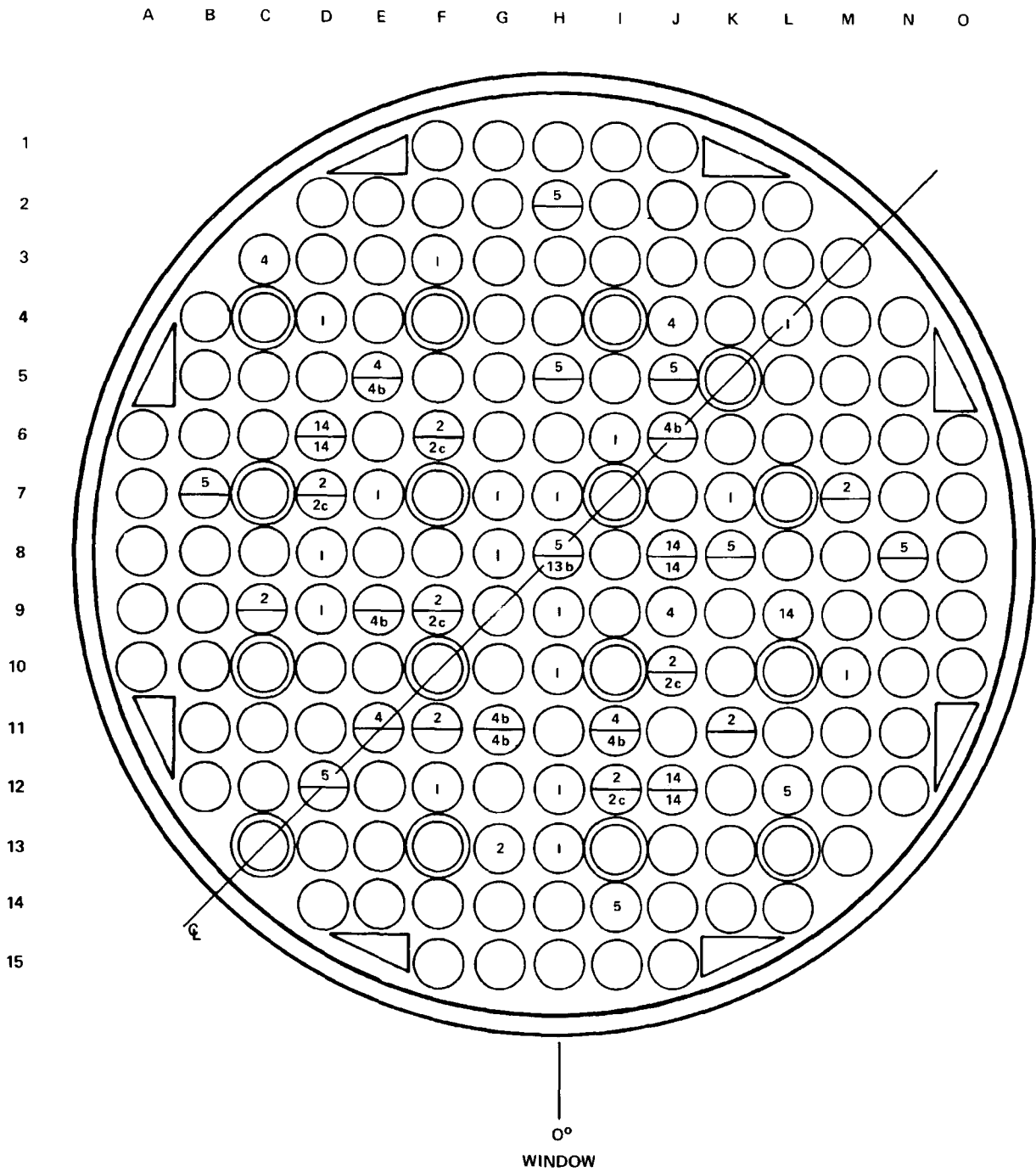

Figure 7-4. Projected Instrumented Heater Rod Locations

#### 7-4. Thimble Instrumentation

Four thimbles will be instrumented with six 1.01 mm (0.04 in.) diameter wall thermocouples each, for the following purposes:

- To evaluate subcooling in the bottom of the bundle. Since the thimbles are thin-wall tubes which store little energy, the thimble thermocouples should record reflood water temperature shortly after quenching.
- To evaluate radiation heat transfer between surfaces in the upper half of the bundle

The radial and axial location of the thermocouples will be essentially the same as in the unblocked bundle task (figure 7-5). This will allow direct one-to-one comparison between the blocked and unblocked bundles.

#### 7-5. Steam Probe Instrumentation

The steam temperature, which is required for data analysis and evaluation efforts, will be measured by means of an aspirating steam probe located within the thimble tube and a self-aspirating steam probe placed in the subchannel. The thimble tube steam probe is essentially the same design as that utilized in the unblocked bundle (figure 7-6). The thimble tube steam probe employs a design in which two steam temperatures are obtained for each thimble tube. To place two steam probes in one thimble, one probe aspirates through the top of the bundle and the other aspirates through the bottom of the bundle. In the unblocked bundle tests, the steam probe which aspirated through the bottom of the bundle did not perform satisfactorily because of the design of the inner radiation shield. The inner radiation shield has been simplified for the blocked bundle, as shown in figure 7-6, to improve the response of the lower steam probe. The subchannel steam probe (figure 7-7) was specially designed and tested for the 21-rod bundle, since no thimble tubes were present in that test series. The steam probes will provide data for evaluating the following:

- Mass and energy balances
- Nonequilibrium vapor properties

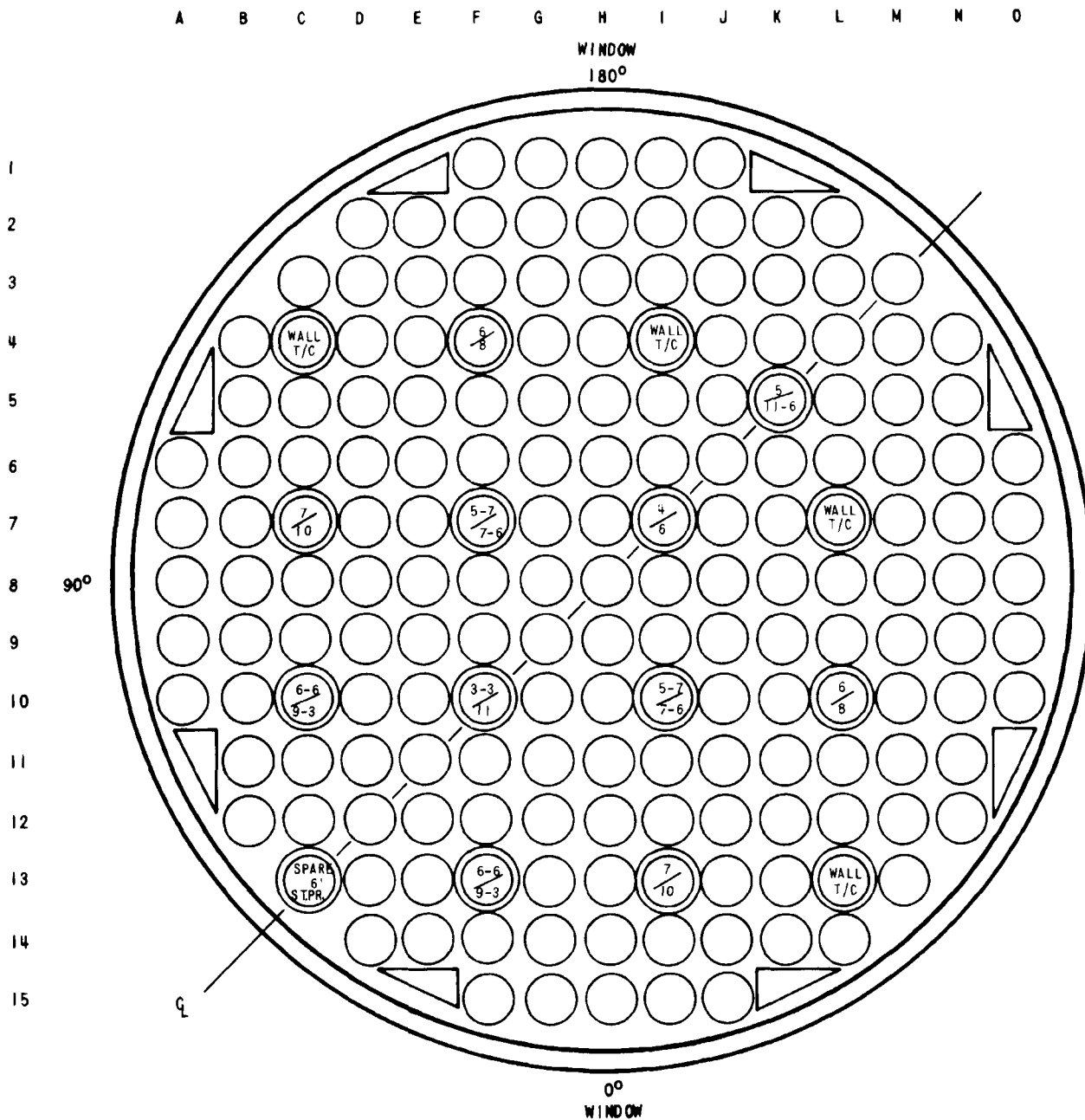

ELEVATION (m)	0.30	0.61	0.99	1.22	1.52	1.70	1.83	1.98	2.13	2.29	2.44	2.82	3.05	3.35	3.51
ELEVATION (in.)	12	24	39	48	60	67	72	78	84	90	96	111	120	132	138
INSTRUMENTATION AVAILABILITY															
NUMBER OF STEAM PROBES	-	-	1	1	1	2	4	2	2	2	2	2	2	1	1
NUMBER OF THIMBLE WALL THERMOCOUPLES	2	2	2	2	2	-	4	-	2	-	4	2	2	-	-

Figure 7-5. Steam Probe and Thimble Wall Thermocouple Locations (161-Rod Bundle Task)

7-12

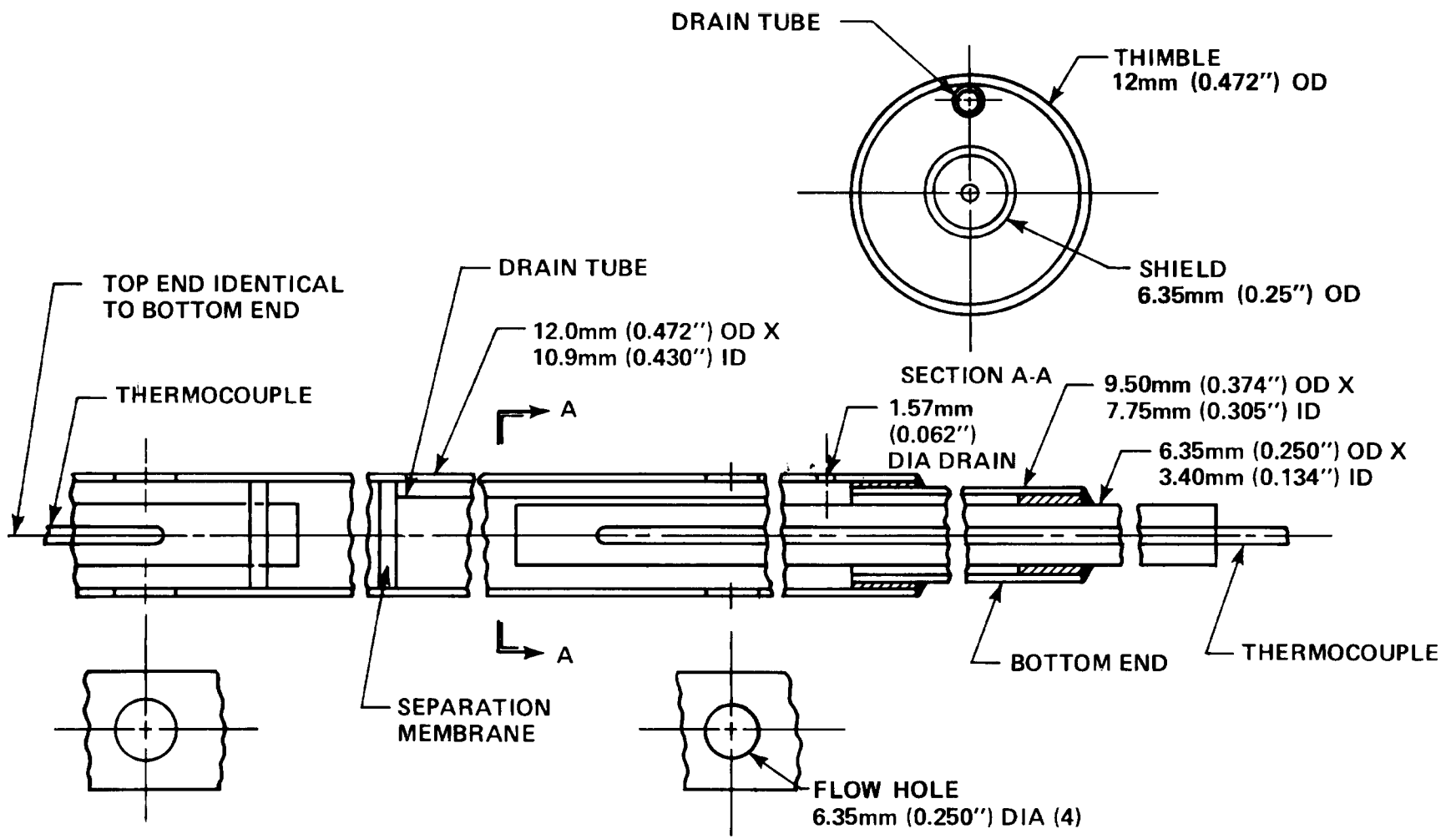

Figure 7-6. Steam Probe Schematic Diagram

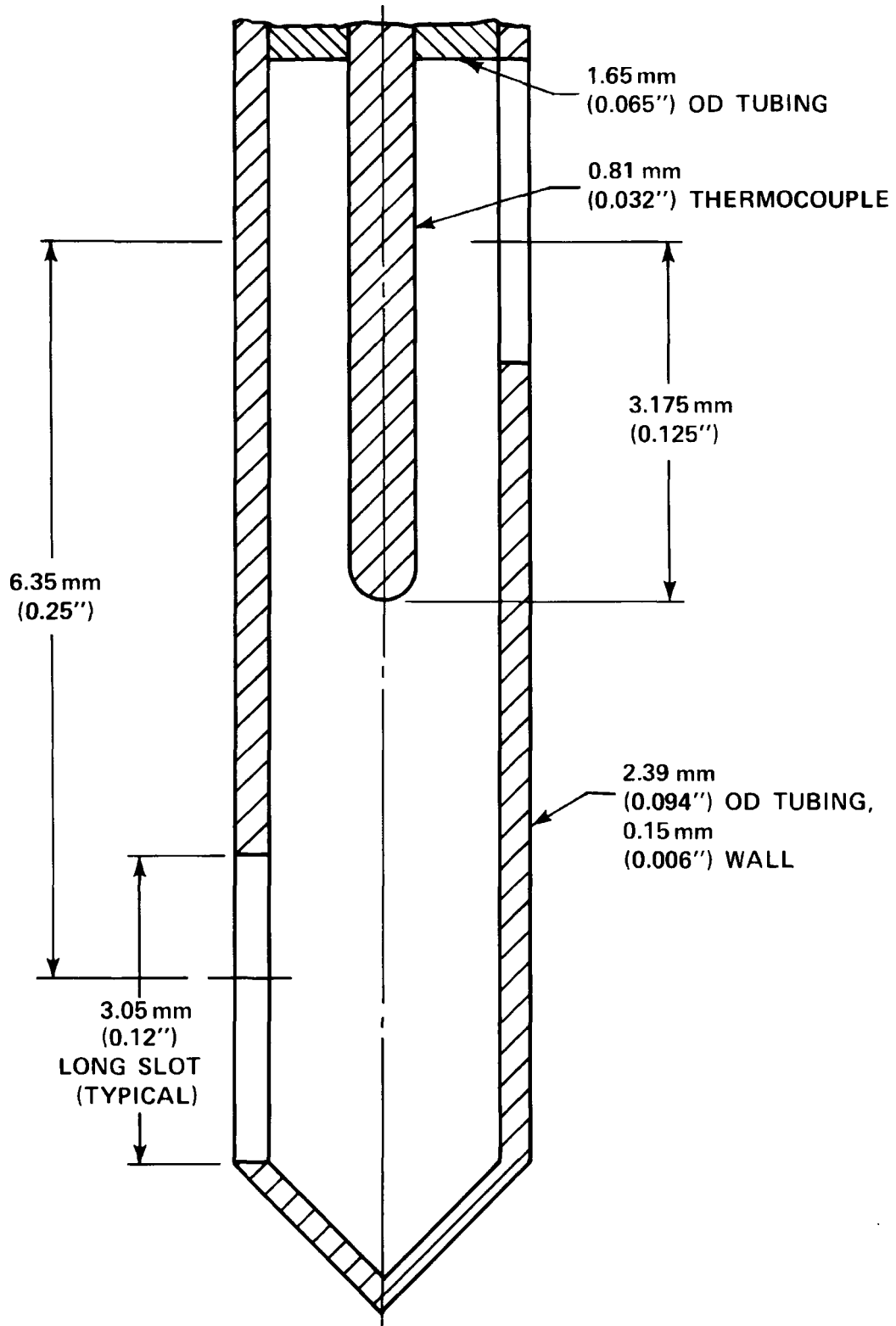

Figure 7-7. Self-Aspirating Subchannel Steam Probe

-- Radial and axial fluid temperature variations

-- Effect of flow blockage sleeves

The radial and axial location of the 23 thimble tube steam probes will be essentially the same as in the unblocked bundle (figure 7-5). This will allow direct one-to-one comparison between the blocked and unblocked bundles.

The subchannel steam probes will be placed in and around the blockage zone of 1.57 to 2.11 m (62 to 83 in.), thereby supplementing the 23 thimble tube steam probes used to obtain bundle-wide steam temperatures for direct comparison to the unblocked bundle data. Although the exact locations of the subchannel steam probes cannot be specified until after the blockage sleeve distribution has been determined from the fifth test series of the 21-rod bundle task, it is expected that a single subchannel in both the blockage region and the bypass region will be instrumented axially with steam probes. However, two of the ten subchannel steam probes will be located adjacent to a thimble tube steam probe, to provide a direct comparison of the two types of steam probes.

#### 7-6. Differential Pressure Measurements

Differential pressure measurements will be made every 0.30 m (12 in.) along the length of the bundle to determine mass accumulation in the bundle. Differential pressure transmitters [ $\pm 3.7$  kPa ( $\pm 15$  in. wg)] are utilized to obtain an accurate mass accumulation measurement representative of an average across the bundle. An additional cell measures the overall pressure drop from the bottom to the top of the heater length. These pressure transmitters are accurate to within 0.20 percent of full scale.

#### 7-7. Power Measurements

Six instrumentation channels are devoted to measurement of power into the bundle. Three are used as a primary measurement from which power is controlled by the computer software. Three independent power measurements will be used for data reduction purposes.

## 7-8. PLENUM AND HOUSING INSTRUMENTATION

Plenum and housing instrumentation is detailed in the following paragraphs.

### 7-9. Upper Plenum

The upper plenum (figure 7-8) is an important component of the FLECHT loop. The upper plenum is utilized to separate the liquid and steam phases in close proximity to the test section so that accurate mass and energy balances can be accomplished. System pressure is controlled from a transducer located in the upper plenum for constant flooding rate tests. Another transducer is connected to the computer for system pressure data acquisition. A differential pressure cell connected between the top and bottom of the upper plenum is used to measure liquid accumulation within this component. Liquid will collect at the bottom of the upper plenum before draining into the carryover tank. In addition, windows are being incorporated to allow visual examination of the separation phenomenon.

Two upper plenum thermocouples are designed to measure the fluid temperature at upper plenum exit and in the upper plenum extension. These thermocouples should indicate the location and presence of liquid in the upper plenum and housing extension. An aspirating steam probe located in the upper plenum at the bundle exit is utilized to measure vapor nonequilibrium temperature.

### 7-10. Lower Plenum

The only instrumentation in the lower plenum (figure 7-8) is a fluid thermocouple, which will be used to measure inlet subcooling as water floods the bundle.

### 7-11. Housing

Housing wall temperatures will be measured to compute housing heat release as part of the overall mass and energy balance analysis. Housing wall temperatures will also be measured in order to evaluate bowing effects. A total of 29 thermocouples, distributed axially and azimuthally on the housing, will be recorded by the computer. Thermocouples

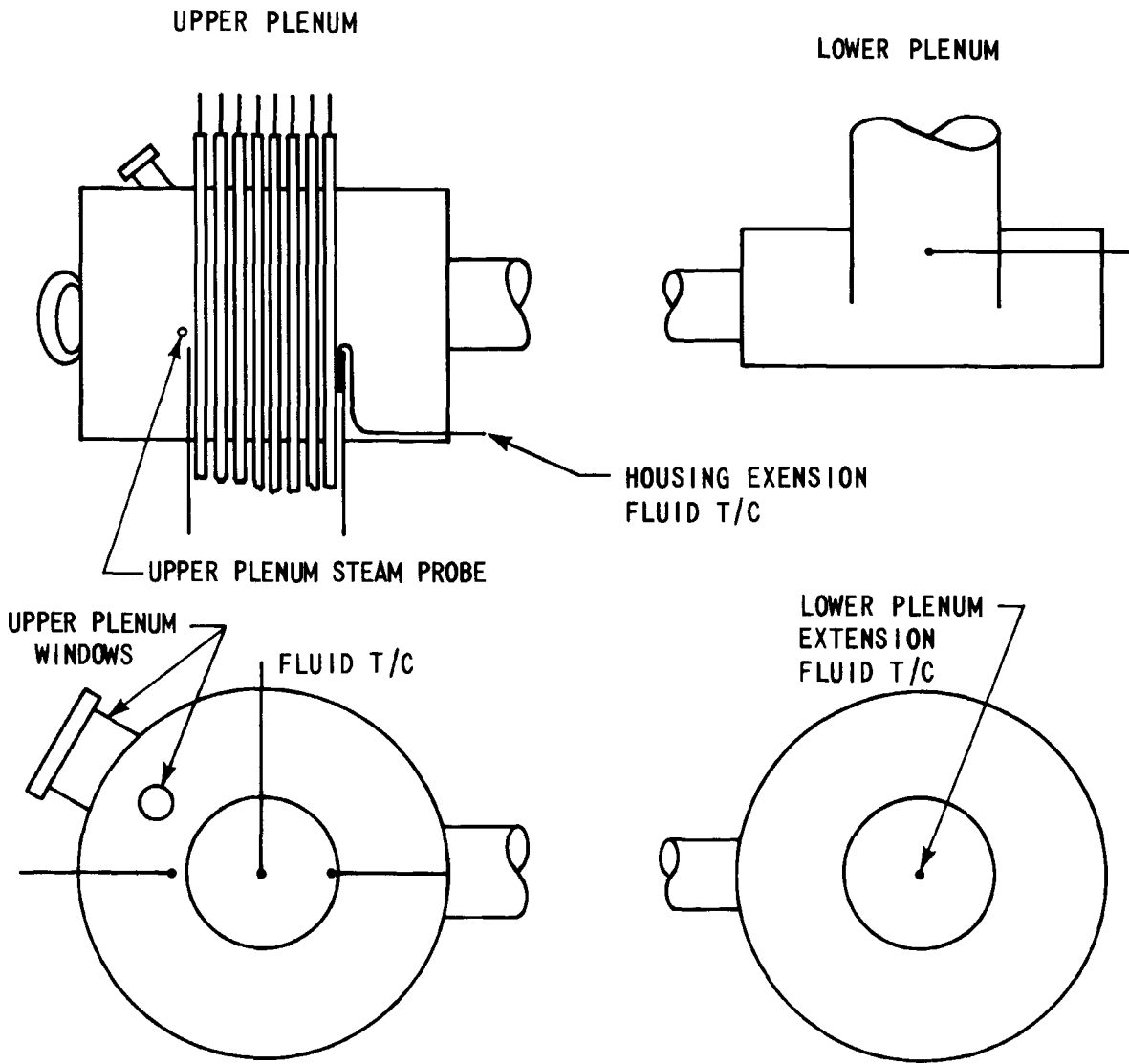

Figure 7-8. Upper and Lower Plenum Thermocouple Locations (161-Rod Bundle Task)

will also be placed every 0.61 m (24 in.) on the outside surface of the insulation, to obtain an accurate measurement of the bundle heat losses.

The FLECHT housing has been equipped with three pairs of windows located at 0.91, 1.83, and 2.74 m (36, 72, and 108 in.) (figure 6-4). These windows will be used to make visual observations and motion pictures of two-phase flow regimes and quench front progression. Good visibility through the quartz windows is a prerequisite for quality movies. In previous FLECHT tests, a liquid film which formed on the inside of the glass obstructed the viewing area. In the unblocked bundle tests, heaters were placed on the outside of the window housing and the window temperature was monitored by connection to the computer. The heaters raised the inner surface of the quartz to approximately 260°C (500°F) prior to initiation of test. At this point, the heaters were turned off. The windows maintained their temperature because of heat input from rods. The same procedure will be utilized in the blocked bundle tests.

#### 7-12. LOOP INSTRUMENTATION

Thirty-one computer channels have been assigned to the collection of temperature, flow, and pressure data throughout the loop, exclusive of the instrumentation found in the upper and lower plenum, bundle, and housing (figure 7-9). This instrumentation includes 10 fluid thermocouples, 7 wall thermocouples, 3 turbine meters, 9 differential pressure cells, and 2 pressure cells.

The ten fluid thermocouples are placed in the water supply system, the exhaust line, the carryover tank, the steam separator, the steam separator drain tank, the crossover leg (gravity reflood tests), and the downcomer (gravity reflood tests). The fluid thermocouples are utilized to measure the temperature of either stored or injected flow. Two of these thermocouples are utilized in aspirating steam probes placed in the elbows of the exhaust line on either side of the steam separator. These steam probes are designed to measure vapor nonequilibrium in the test section exit and the desuperheating effect of the steam separator. The design of this steam probe is shown in figure 7-10.

The seven wall thermocouples to be monitored by the computer have been placed on the carryover tank, steam separator, steam separator drain tank, and exhaust line. This

instrumentation is utilized to control the heatup period such that component wall temperatures are at  $T_{SAT} + 11.1^{\circ}\text{C}$  ( $T_{SAT} + 20^{\circ}\text{F}$ ). This instrumentation is also used to estimate the heat release from the fluid to the loop components during the test.

The three turbine meters are utilized to measure the flow rate of injected water in both the forced flooding and gravity reflooding tests. One turbine meter is used to measure the injected flow for the forced flooding tests, and two turbine meters, one in the injection line and one in the crossover leg, are used to measure flow for the gravity reflooding tests. The turbo-probe in the crossover leg is bidirectional, to measure both forward and reverse flow into and out of the test section.

The nine differential pressure cells are used to measure injected flow or separated water accumulation. The accumulator tank has a differential pressure cell which can be utilized as a backup to or a check on the injection line turbine meters. The three storage tanks on the downstream side of the bundle, the carryover tank, the steam separator, and the steam separator drain tank, are each instrumented with differential pressure cells to measure liquid accumulation. The exit steam flow is measured downstream of the steam separator utilizing an orifice plate, differential pressure cell, fluid thermocouple, and pressure cell. Four additional differential pressure cells are utilized in the gravity reflood tests to measure mass accumulated in the downcomer, and to measure differential pressures between the downcomer and bundle, between the upper plenum and steam separator, and between the top of the downcomer and the steam separator.

The two loop pressure cells are utilized to measure the absolute pressure at the orifice plates on the bundle inlet and outlet, and at the steam separator in the gravity reflood tests.

The loop instrumentation has been set up to provide redundant measurements and eliminate computer channel reassignments between forced flooding tests and gravity reflood tests, as previously required in unblocked bundle tests. This instrumentation design will allow for efficient facility turnaround for conducting the tests.

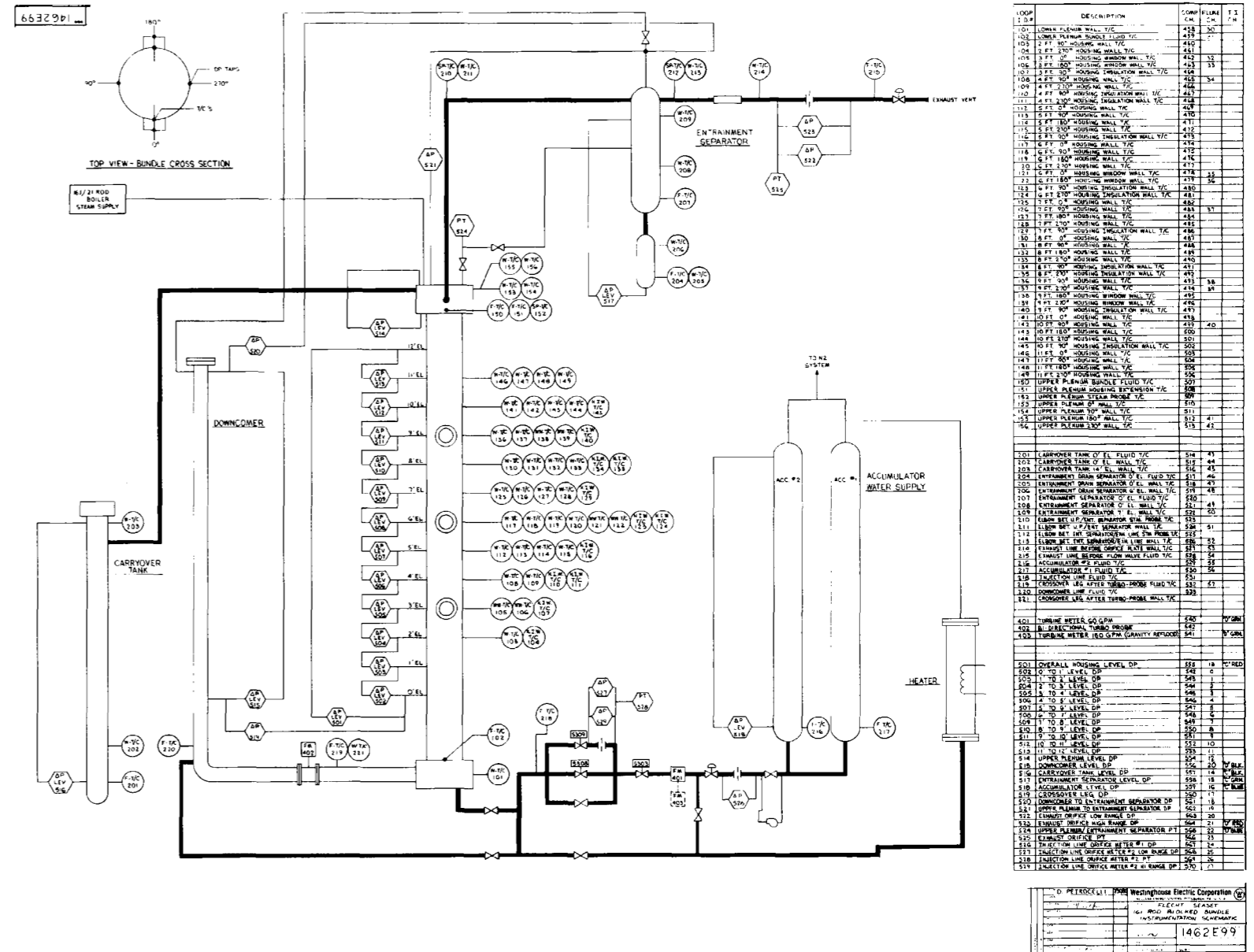

Figure 7-9. 161-Rod Blocked Bundle Task Loop Instrumentation



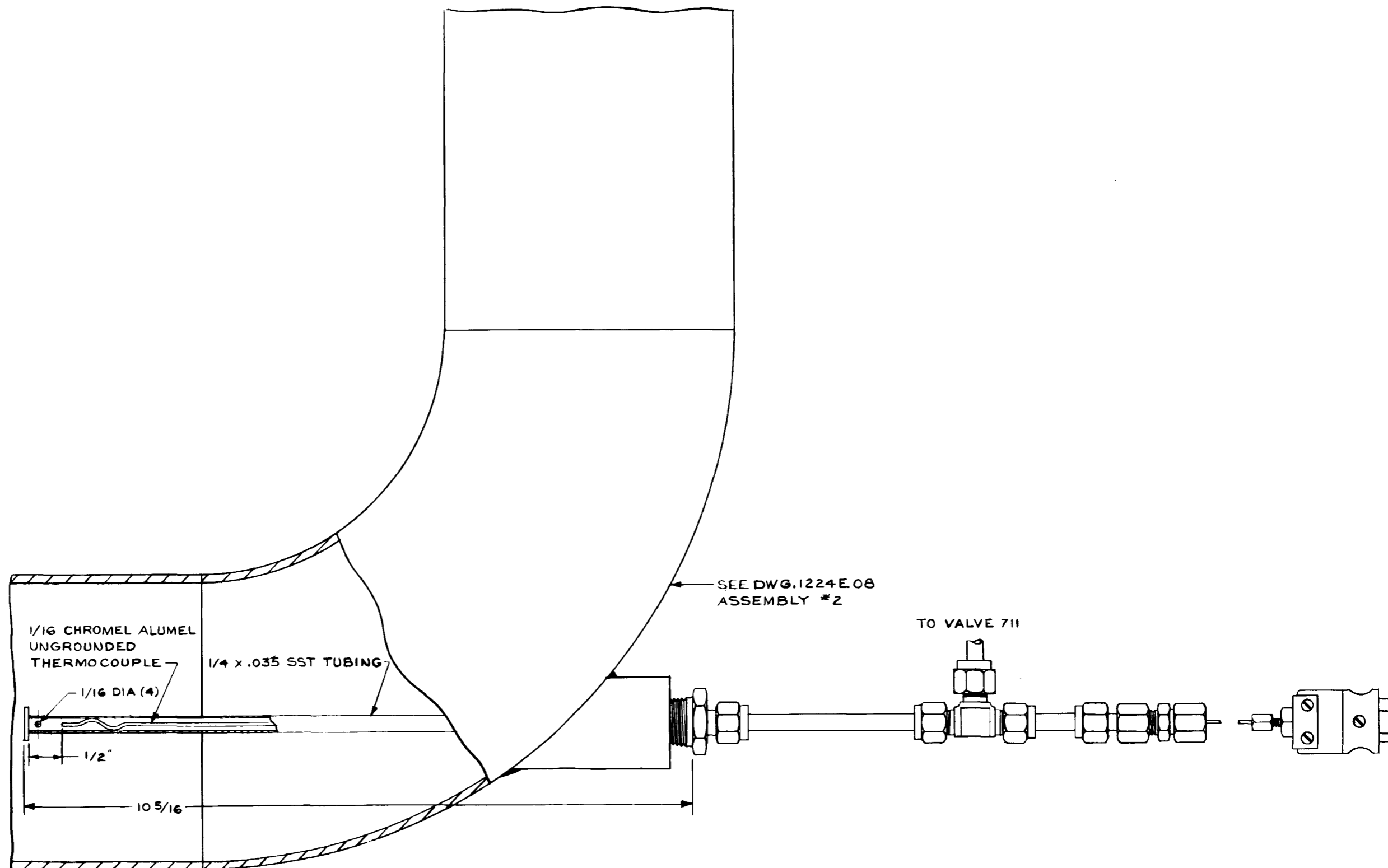

Figure 7-10. Exhaust Line Steam Probe  
(161-Rod Bundle Task)



### 7-13. DATA ACQUISITION AND PROCESSING SYSTEM

Three types of recording systems will monitor the instrumentation on the FLECHT facility. Figures 7-9 and 7-10 are the facility instrumentation schematic diagrams which can be used in conjunction with table 7-2 to locate and identify all the facility instrumentation monitored by the various data acquisition systems. The data acquisition consists of a PDP-11 computer, a Fluke data logger, and Texas Instruments strip chart pen recorders.

### 7-14. Computer Data Acquisition System (CDAS)

The CDAS, the primary data collecting system used on the FLECHT facility, consists of a PDP-11 computer and associated equipment. The system can record 527 channels of analog input data representing bundle and system temperatures, bundle power, flows, and absolute and differential pressures. The computer is capable of storing approximately 2500 data scans for each of the 527 analog input channels.

Typically, each data channel can be recorded once every second until flood, then once every half second for 200 seconds, and then back to once every second thereafter to a maximum of 2500 data points.

The computer software has the following features:

- A calibration file to convert raw data into engineering units
- A preliminary data reduction program which transfers the raw data stored on disk to a magnetic tape, in a format which is compatible for entry into a Control Data Corporation 7600 computer
- A program called FLOOK which reduces raw data into engineering units; a program called FVALID which prints out key data used in validating FLECHT SEASET runs; and a PLOT program, which plots up to four data channels on a single graph. All three programs are utilized to quickly understand and evaluate test runs.

TABLE 7-2

## BUNDLE INSTRUMENTATION REQUIREMENTS

Instrumentation	Number of Channels Used <sup>(a)</sup>			
	CDAS	Fluke	Strip Chart Recorders	Spare Channels
Rod Bundle				
Heater rod thermocouples	400 (178)	-	4 (4)	0 (289)
Thimble tube thermocouples	24 (6)	10 (8)	-	0 (10)
Steam probes				
Aspirating (thimble tube type)	23 (22)	-	6 (6)	0 (1)
Self-aspirating (21-rod bundle type)	10 (0)	-	0 (0)	0 (0)
Differential pressure cells	13 (13)	13 (13)	1 (1)	-
Power				
Primary	3 (3)	-	3 (3)	-
Independent	3 (3)	-	-	-
Housing				
Wall thermocouples	29 (0)	0 (12)	-	0 (17)
Window thermocouples	-	6 (6)	-	-
Insulation thermocouples	12 (0)	0 (0)	-	-

a. The number in parentheses is the number of channels used in the unblocked bundle facility.

TABLE 7-2 (cont)

## BUNDLE INSTRUMENTATION REQUIREMENTS

Instrumentation	Number of Channels Used			
	CDAS	Fluke	Strip Chart Recorders	Spare Channels
<b>Upper Plenum</b>				
Pressure	1 (1)	-	1 (1)	-
Differential pressure cell	1 (1)	1 (1)	-	-
Fluid thermocouples	2 (3)	-	-	-
Wall thermocouples	3 (0)	1 (1)	-	-
Steam probe	1 (0)	-	-	-
<b>Lower Plenum</b>				
Fluid thermocouples	1 (1)	1 (2)	-	-
<b>Total Bundle Channels</b>	<b>525 (231)</b>	<b>32 (43)</b>	<b>15 (15)</b>	<b>0 (317)</b>
<b>Loop</b>				
Water supply system				
Fluid thermocouples	1 (1)	2 (2)	1 (0)	-
Flowmeters (turbine meters)	2 (4)	2 (1)	2 (4)	-
Accumulator differential pressure cell	1 (1)	-	1 (1)	-

TABLE 7-2 (cont)

## BUNDLE INSTRUMENTATION REQUIREMENTS

Instrumentation	Number of Channels Used			
	CDAS	Fluke	Strip Chart Recorders	Spare Channels
Loop (cont)				
Exhaust system				
Steam probe	2 (1)	-	-	-
Fluid thermocouples	4 (3)	2 (2)	-	-
Wall thermocouples	7 (5)	8 (8)	-	-
Pressure	1 (1)	-	-	-
Differential pressure cells:				
Tank levels	3 (3)	-	2 (2)	-
Orifice plate $\Delta P$	1 (1)	-	1 (1)	-
Gravity reflood test (additional)				
Differential pressure cells:				
Downcomer/bundle	1 (0)	-	-	-
Downcomer level	1 (1)	-	1 (1)	-
Upper plenum/steam separator	1 (1)	-	-	-
Downcomer/steam separator	1 (1)	-	-	-
Bidirectional turbine meter	1 (1)	-	1 (1)	-

TABLE 7-2 (cont)

BUNDLE INSTRUMENTATION REQUIREMENTS

Instrumentation	Number of Channels Used			
	CDAS	Fluke	Strip Chart Recorders	Spare Channels
Loop (cont)				
Crossover leg				
Fluid thermocouple	1 (0)	-	-	-
Downcomer fluid thermocouple	1 (1)	-	-	-
Crossover pipe wall	-	1 (1)	-	-
Steam separator pressure	1 (0)	-	-	-
Injection line fluid thermocouple	1 (0)	-	-	-
Total Loop Channels	31 (25)	15 (14)	9 (10)	-
TOTAL CHANNELS	556 (256)	47 (57)	24 (25)	0 (317)

7-27

In addition to its role as a data acquisition system, the computer also plays a key role in the performance of an experimental run. Important control functions include initiation and control of reflow flow and power decay as well as termination of bundle power in the event of an overtemperature condition. Table 7-2 lists the instrumentation recorded on the CDAS.

#### 7-15. Fluke Data Logger

The Fluke data logger has 60 channels of analog input for monitoring loop heatup and aiding in equipment troubleshooting. The Fluke records key facility vessel and fluid temperatures, displaying temperature directly in degrees Fahrenheit. This makes the task of monitoring loop heatup more efficient. The Fluke also records millivolt data from the test section differential pressure cells, allowing the operator to keep a check on their operation and repeatability. The Fluke is further used to troubleshoot problems with loop equipment in a quick and convenient manner. Table 7-2 lists channels monitored on the Fluke.

#### 7-16. Multiple Pen Strip Chart Recorders

Four Texas Instruments strip chart recorders are used to record bundle power; selected bundle thermocouples; reflow line turbine meter flows; accumulator, separator drain tank, housing, and carryover tank levels; and exhaust orifice differential pressure. These recorders give the loop operators and test directors immediate information on test progress and warning in the event of system anomalies. The strip charts give an analog recording of critical data channels as a backup to the computer. Strip charts are also needed during the heatup phase of the facility when the computer is not available. Table 7-2 lists the channels associated with the strip chart recorders.

#### 7-17. DATA VALIDATION CRITERIA AND PROCEDURES

The data validation process is initiated when all instrumentation is checked for proper operation prior to the actual running of a test. A reading from each channel is recorded and compared to the expected value for that channel. In this manner, an abnormal reading will indicate a problem in that channel and corrective actions will be taken

before the actual test is run. This channel verification procedure will increase the probability that all instrumentation will work properly once a test is under way.

If some instrumentation fails just prior to or during a test but the remaining instrumentation is sufficient to calculate overall mass balances, void fraction in the test section, some heat transfer coefficients, fluid temperatures, and carryout fraction, then the run may still be considered valid. If the instrumentation is not sufficient for these calculations, the run is considered invalid and will be repeated. When too many rod bundle and/or fluid thermocouples fail in critical locations, serious consideration will be given to discontinuing testing and repairing or replacing the affected channels. In any event, an attempt will be made to repair any failure before another test is performed.

The following criteria are used to determine if sufficient instrumentation exists for conducting a valid test:

- The number of heater rod thermocouples required to be functioning properly for a valid test must be sufficient to meet task objectives.
- For flooding rates above 3.8 cm/sec (1.5 in./sec), the upper plenum differential pressure cell is required to be functioning properly for a valid test. Of the 12 bundle differential pressure cells, no more than one can fail for the test to be valid.
- Of the test section steam probes, five have been selected at the 1.83, 2.13, 2.44, and 3.05 m (72, 84, 96, 108, and 120 in.) elevations along with the two exit steam probes as required to be functional for a valid test.
- The upper plenum pressure transducer is required to be functioning properly for all tests except the gravity reflood tests. The steam separator pressure transducer is required to be functional for gravity reflood tests.
- For a valid test, one lower plenum and one upper plenum fluid thermocouple are also required to be functional.

- (3) Injection line turbine meters
- (4) Steam separator pressure transducer
- (5) Upper plenum/steam separator differential pressure cell
- (6) Downcomer/steam separator differential pressure cell

A run specification and validation sheet will be completed (appendix D). This sheet specifies the initial test conditions and the validation requirements for each FLECHT SEASET 161-rod blocked bundle test. It also provides space for comments on run conditions, causes for terminating and invalidating a run, instrumentation failures, preliminary selected thermocouple data, and drained water weights from collection tanks and the test section.

Once the instrumentation has checked out satisfactorily and the test has been run, the data for each channel are scrutinized to see if the system behaved as expected. Abnormal behavior of a data channel is investigated to determine if it is due to equipment malfunction or to a physical phenomenon. These procedures, along with periodic equipment calibrations, are designed to assure that the data recorded are accurate and reliable.

Another aspect of data validation is considered once the instrumentation reliability has been determined. The actual test conditions are compared to the parameters specified by the test matrix to see if the run satisfies the test matrix. The facility conditions before initiation of reflood are compared to the expected values for such parameters as bundle power, system pressure, average vessel wall temperature, and hottest thermocouple at the start of reflood. The injection flow is checked against what has been specified and the system pressure is reviewed to see if the system pressure control worked properly.

After the instrumentation is functionally checked and the test parameters and performance compared with the test matrix, the final validation is performed during data analysis. In the process of analysis, a system mass and energy balance is computed. These calculations determine if the data are within the specified accuracy and whether the instrumentation is adequate for analyzing what has happened in the system.

- It is required, for the test section bundle power supply, that the one independent power meter be functioning properly for a valid test. Also, this power measurement must be within the accuracy range specified for a test.
  
- Four loop fluid thermocouples are required for a valid test, as follows:
  - (1) Carryover tank - 0.0 m (0 in.)
  - (2) Steam separator drain tank - 0.0 cm (0 in.) elevation
  - (3) Exhaust orifice
  - (4) Accumulator fluid thermocouple
  
- Four additional loop wall thermocouples are required for a valid test, as follows:
  - (1) Upper plenum
  - (2) Carryover tank - 0.0 m (0 in.) elevation
  - (3) Steam separator drain tank - 0.0 cm (0 in.) elevation
  - (4) Test section hot leg
  
- The injection line turbine meter must be functioning properly for a valid test.
  
- Three liquid level measurements are required for a valid test, as follows:
  - (1) Carryover tank
  - (2) Steam separator
  - (3) Accumulator
  
- At the exhaust orifice, both the orifice differential pressure measurement and the static pressure measurement upstream of the orifice are required to be functional.
  
- For the gravity reflood tests, the additional instrumentation required to be functioning is as follows:
  - (1) Downcomer level differential pressure cell
  - (2) Bidirectional turbine meter



## SECTION 8

# TEST MATRIX

### 8-1. INTRODUCTION

Paragraphs 8-2 through 8-18 of this section describe the forced reflood and gravity reflood shakedown tests required to ensure that the FLECHT SEASET 161-rod bundle test loop will operate properly and perform tests specified in the test matrix. The test matrix (paragraph 8-19) is designed to meet the task objectives and fulfill the data requirements discussed in sections 3 and 5.

### 8-2. SHAKEDOWN TEST MATRIX

Prior to conducting the reflood tests outlined in paragraph 8-19, a series of shakedown tests will be run on the test facility. These shakedown tests will be conducted not only on separate facility components but also on the completely assembled test facility.

The purpose of the shakedown tests is to ensure that the instrumentation, control, and data acquisition systems are working properly so that useful and valid data can be obtained during the reflood experiments. Some of the shakedown tests are also intended to verify and adjust control procedures. A brief summary of each shakedown test follows.

### 8-3. Thermocouple Wiring Connection Checks

The purpose of this test is to check the continuity of each thermocouple wiring connection from the patch board to the computer. If any deviation is observed, the circuit will be checked, repaired, and retested.

### 8-4. Forced Reflood Configuration Testing

The following list of tests outlines another portion of the shakedown test matrix. It covers those shakedown tests conducted on the completely assembled test facility in the forced reflood configuration.

8-5. Heater Rod Power Connection Check - This test is intended to check the continuity of each heater rod power connection at the fuse panel. If any abnormal reading is observed, the circuit will be checked, repaired, and retested.

8-6. Instrumented Heater Rod Radial Location and Corresponding Thermocouple Checks - This test is intended to check the following items:

- For each instrumented heater rod, all corresponding thermocouples are checked for correct computer channel hookup and proper data recording.
- During the above check, radial power connections between the fuse panel and the appropriate heater rod are confirmed.
- The output polarity of each thermocouple at the computer is also checked.

8-7. Heater Rod, Thimble, and Steam Probe Thermocouple Axial Location Checks - This test is intended to check the following items:

- For each bundle thermocouple elevation, all corresponding heater rod, thimble, and steam probe thermocouples are checked for appropriate computer channel axial hookup and proper recording of data.
- In completing the above check, each heater rod, blockage sleeve, thimble, and steam probe thermocouple elevation is confirmed.

8-8. Test Section Differential Pressure Cell Axial Locations, Steam Separator Collection Tank and Carryover Tank Volume, and Level Transmitter Checks - This test is intended to check the following items:

- Test section differential pressure cells are checked for appropriate computer channel axial hookup.
- Test section control volumes are established in 0.30 m (12 in.) increments.
- The lower plenum volume is checked.

- The steam separator collection tank and the carryover tank volumes are determined.
- The steam separator collection tank and the carryover tank level transmitters, along with the test section differential pressure cells, are checked for proper operation.

8-9. Pressure Control Valve Operation, Exhaust Orifice Plate Flow, and Differential Pressure Cell Zero Shift Checks - This test is intended to check the following items:

- The test section, tank, and orifice differential pressure cells zero readings and zero shifts are checked.
- The response of the pressure control valve to sudden changes in flow is also checked.

8-10. Turbine Flowmeter Calibration and Flow Control Valve Operation Checks - This test is intended to check the following items:

- A spot check of turbine meter calibration (for agreement with the full flow range calibrations performed prior to the shakedown tests) is conducted.
- The flowmeters are checked for appropriate computer channel hookup.
- Flow control valve response to a continuously variable flooding signal is also checked.

8-11. Carryover Tank, Steam Separator Tank, and Connecting Piping Heatup Checks - This test is intended to evaluate the pretest heatup of the test facility tanks and connecting piping. The heatup of this portion of the test facility is achieved initially by powering strip heaters attached to the outside surfaces and then circulating slightly superheated steam through the facility. Loop thermocouple temperatures are reviewed to determine temperature uniformity of the tanks and piping walls both before

and after the steam is injected. The time needed for heating the facility components to the required temperatures is also determined from this test.

8-12. Motion Picture Check - The experience gained from the unblocked bundle test program<sup>(1)</sup> will be utilized in the operation of the movie cameras.

8-13. Low-Power and Low-Temperature Test, Forced Reflood Configuration - This shakedown test, a trial run for the complete test facility in the forced reflood configuration, is conducted according to normal procedures (paragraph 6-11), with care taken to meet all requirements for a valid run (paragraph 7-16). Test conditions are a nominal 0.28 MPa (40 psia) run having low power 1.31 kw/m (0.4 kw/ft) , low initial clad temperature (260°C (500°F) , and 3.8 cm/sec (1.5 in./sec) flooding rate.

8-14. Steam Probe Operation Check - The steam probe operation test at 0.28 MPa (40 psia) upper plenum pressure will be run in conjunction with the low-power and low-temperature shakedown test (paragraph 8-13). The 23 steam probes located in the test vessel are grouped by elevation into six manifold systems. Each manifold outlet empties into a separate ice-packed collection tank at atmospheric pressure. These tests have the following objectives:

- To check the amount of steam flow through each of the six manifolds
- To determine a reasonable response to changing flow conditions from all steam probe thermocouples
- To check the operating procedure for steam probe valving, manifolding, and condensate measurement
- To measure operating pressures throughout the test vessel for steady-state flow conditions, to determine the steam probe to atmosphere pressure differential

---

1. Hochreiter, L.E., et al., "PWR FLECHT SEASET Unblocked Bundle, Forced and Gravity Reflood Task: Task Plan Report," NRC/EPRI/Westinghouse-3, March 1978.

## 8-15. Gravity Reflood Configuration Testing

Gravity reflood modifications and testing will be scheduled after completion of the forced reflood testing. The shakedown tests listed below will be conducted on the completely assembled facility after it has been modified for the gravity reflood configuration (paragraph 6-1).

8-16. High-Range Turbine Flowmeter Flow Checks - With the facility modified for the gravity reflood testing, this shakedown test is intended to check the following items:

- The flowmeters are checked for appropriate computer channel hookup.
- A spot check of the new high-range turbine meter calibration is made for agreement with the full flow range calibrations conducted prior to the shakedown tests.

8-17. Bidirectional Turbo-Probe Flow Checks - With the facility in the gravity reflood configuration, this shakedown test is intended to be a functional check of the bidirectional turbo-probe calibration for agreement with its full flow range calibrations. This test is conducted in two phases: the first with the turbine meter oriented in its forward direction and the second with the turbine meter turned 3.14 radians (180 degrees) to check the reverse flow measurements of the instrument. The turbo-probe instrumentation is also reviewed for appropriate computer channel hookup.

8-18. Low-Power and Low-Temperature Test, Gravity Reflood Configuration - This shakedown test, a trial run for the complete test facility in the gravity reflood configuration, is conducted according to normal procedures (paragraph 6-11), with care taken to meet all requirements for a valid run (paragraph 7-16). Test conditions are a nominal 0.28 MPa (40 psia) run having low power [1.6 kw/m (0.5 kw/ft)], low initial clad temperature [457°C (855°F)], and injection flow the same as test 20 in the test matrix.

## 8-19. TEST MATRIX

A test matrix was designed to satisfy the objectives in this task (section 3) and is presented in table 8-1. This test matrix is based on the tests conducted in the unblocked

bundle,<sup>(1)</sup> to allow comparison to the unblocked bundle data. Each of the two bundle configurations listed in paragraph 4-4 will be subjected to the same test conditions tabulated in table 8-1.

The test parameters are centered on two containment pressures, representing the range applicable to PWR plants (figure 8-1). Within these containment pressures, initial clad temperature, peak power, flooding rate (or injection rates for gravity reflood tests), and inlet subcooling are varied to determine reflood behavior (maximum clad temperature, turnaround time, quench time, and mass effluent) and heat transfer capability on a comparable basis with previous FLECHT rod geometries. This test matrix has parameter effects similar to those in the previous FLECHT unblocked bundle tests.

#### 8-20. Constant Flooding Rate

Data from these tests will be used to examine the effects of flooding rates on heat transfer and entrainment. These tests will be used as base for comparisons with other test series and to study effects of various flooding rates at reference conditions such as pressure, rod initial clad temperature, and inlet subcooling.

However, for tests 5 and 6, the peak power has been reduced to 1.31 kw/m (0.4 kw/ft) and 0.88 kw/m (0.27 kw/ft), respectively, because unblocked bundle testing and calculations showed that peak clad temperatures above 1232°C (2250°F) could be reached for the test bundle if the rod peak power were 2.3 kw/m (0.7 kw/ft). These elevated temperatures would reduce the life of the rod bundle.

#### 8-21. Pressure Effects

The parametric effect of pressure on heat transfer and entrainment at 0.014 MPa (20 psia) and 0.41 MPa (60 psia) at reference conditions will be studied by comparing the results of tests 7 and 10, respectively, of this series with the results of test 3 of series 1. These data will also be used to determine the effect of decreasing flooding rates on heat transfer and entrainment at low pressures (tests 8 and 9).

---

1. Hochreiter, L. E., et al., "PWR FLECHT SEASET Unblocked Bundle, Forced and Gravity Reflood Task: Task Plan Report," NRC/EPRI/Westinghouse-3, March 1978.

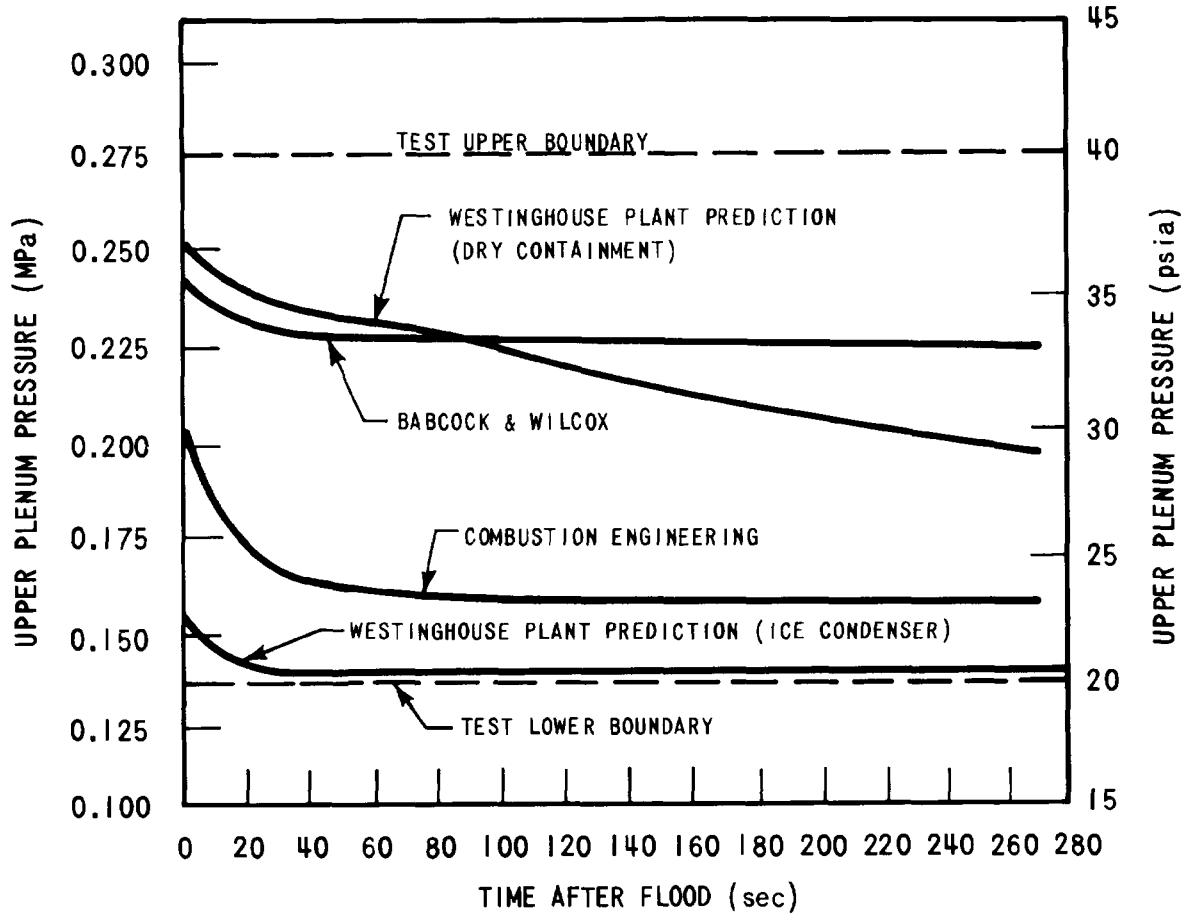

Figure 8-1. Test-Simulated Boundaries of Predicted Upper Plenum Pressures During Reflood

TABLE 8-1

## TEST MATRIX FOR 161-ROD BUNDLE FLOW BLOCKAGE TASK

Test No.	Pressure [MPa (psia)]	Rod Initial Temperature [ $^{\circ}\text{C}$ ( $^{\circ}\text{F}$ )]	Rod Peak Power [kw/m (kw/ft)]	Flooding Rate [mm/sec (in./sec)]	Inlet Subcooling [ $^{\circ}\text{C}$ ( $^{\circ}\text{F}$ )]	Parameter	Test Series
1	0.276 (40)	871 (1600)	2.3 (0.7)	152.0 (6.0)	78 (140)	Constant flooding rate	1 (reference)
2	0.276 (40)	871 (1600)	2.3 (0.7)	38.1 (1.5)	78 (140)		
3	0.276 (40)	871 (1600)	2.3 (0.7)	25.4 (1.0)	78 (140)		
4	0.276 (40)	871 (1600)	2.3 (0.7)	20.3 (0.8)	78 (140)		
5	0.276 (40)	871 (1600)	1.3 (0.4)	16.2 (0.6)	78 (140)		
6	0.276 (40)	871 (1600)	0.88 (0.27)	10.1 (0.4)	78 (140)		
7	0.138 (20)	871 (1600)	2.3 (0.7)	25.4 (1.0)	78 (140)	Pressure effects	2
8	0.138 (20)	871 (1600)	1.3 (0.4)	16.2 (0.6)	78 (140)		
9	0.138 (20)	871 (1600)	0.88 (0.27)	10.1 (0.4)	78 (140)		
10	0.414 (60)	871 (1600)	2.3 (0.7)	25.4 (1.0)	78 (140)		
11	0.276 (40)	871 (1600)	2.3 (0.7)	25.4 (1.0)	3 (5)	Subcooling effect	3
12	0.276 (40)	538 (1000)	2.3 (0.7)	38.1 (1.5)	78 (140)	Initial clad temperature	
13/14	0.276 (40)	871 (1600)	2.3 (0.7)	25.4 (1.0)	78 (140)	Repeat test	4
15	0.276 (40)	871 (1600)	2.3 (0.7)	152.4 (6) (5 sec) 20.3 (0.8) (onward)	78 (140)	Variable stepped flow	5

TABLE 8-1 (cont)

TEST MATRIX FOR 161-ROD BUNDLE FLOW BLOCKAGE TASK

Test No.	Pressure [MPa (psia)]	Rod Initial Temperature [ <sup>o</sup> C( <sup>o</sup> F)]	Rod Peak Power [kw/m (kw/ft)]	Flooding Rate [mm/sec (in./sec)]	Inlet Subcooling [ <sup>o</sup> C ( <sup>o</sup> F)]	Parameter	Test Series
16	0.276 (40)	871 (1600)/ 260 (500)	2.3 (0.7)/ 1.3 (0.4)	25.4 (1.0)	78 (140)	Hot and cold channels	6
17	0.276 (40)	871 (1600)/ 260 (500)	2.3 (0.7)/ 1.3 (0.4)	20.3 (0.8)	78 (140)		
18	0.276 (40)	871 (1600)/ 260 (500)	2.3 (0.7)/ 1.3 (0.4)	38.1 (1.5)	78 (140)		
				Flow Rate [kg/sec (lb/sec)]			
19	0.276 (40)	871 (1600)	2.3 (0.7)	6.49 (14.3) (14 sec) 0.816 (1.8) onward	78 (140)	Gravity Reflood	7
20	0.138 (20)	871 (1600)	2.3 (0.7)	6.49 (14.3) (14 sec) 0.816 (1.8) onward	78 (140)		

#### 8-22. Coolant Subcooling Effects

Data from this test will be used to examine the effects of coolant subcooling at 0.28 MPa (40 psia) by comparing results of test 11 and test 3. It would also be desirable to perform the test with the coolant at saturation temperature (no subcooling). However, this would cause cavitation across the injection line and flowmeters, thereby impeding proper flooding rate measurements and, consequently, mass balance calculations.

#### 8-23. Low Initial Clad Temperature

This test will provide data for the study of entrainment from cold channels with low initial stored energy at the beginning of reflood.

#### 8-24. Repeat Tests

Statistical analysis will be performed on the results of this test to determine repeatability and validity of the heat transfer coefficient and entrainment data within the test matrix. Tests 13 and 14 are planned to be run in the middle of and close to the end of the test program. Comparison of the results of tests 13 and 14 with an identical test (test 3) conducted earlier is expected to show that use of the bundle and its instrumentation does not influence recorded data from one run to the next.<sup>(1,2)</sup>

#### 8-25. Variable Flooding Rate

The flooding rate predicted by plant analysis<sup>(3,4)</sup> is constantly changing, as shown in figure 8-2 for a dry containment plant and figure 8-3 for an ice condenser plant. Test

- 
1. Lilly, G. P., et al., "PWR FLECHT Cosine Low Flooding Rate Test Series Evaluation Report," WCAP-8838, March 1977.
  2. Lilly, G. P., et al., "PWR FLECHT Skewed Profile Low Flooding Rate Test Series Evaluation Report," WCAP-9183, November 1977.
  3. Cadek, F. F., et al., "PWR Full Length Emergency Cooling Heat Transfer (FLECHT)," WCAP-7665, April 1971.
  4. Cadek, F. F., et al., "PWR FLECHT Final Report Supplement," WCAP-7931, October 1972.

15 has variable stepped flow (figure 8-4), to facilitate data analysis and to enable comparison to unblocked bundle tests having similar initial conditions.

#### 8-26. Gravity Reflood

The effects of gravity reflooding on heat transfer and entrainment at two different pressures will be studied in this series. Tests 19 and 20 will be conducted to evaluate the difference in heat transfer, mass storage in the bundle, and entrainment between gravity and forced flooding.

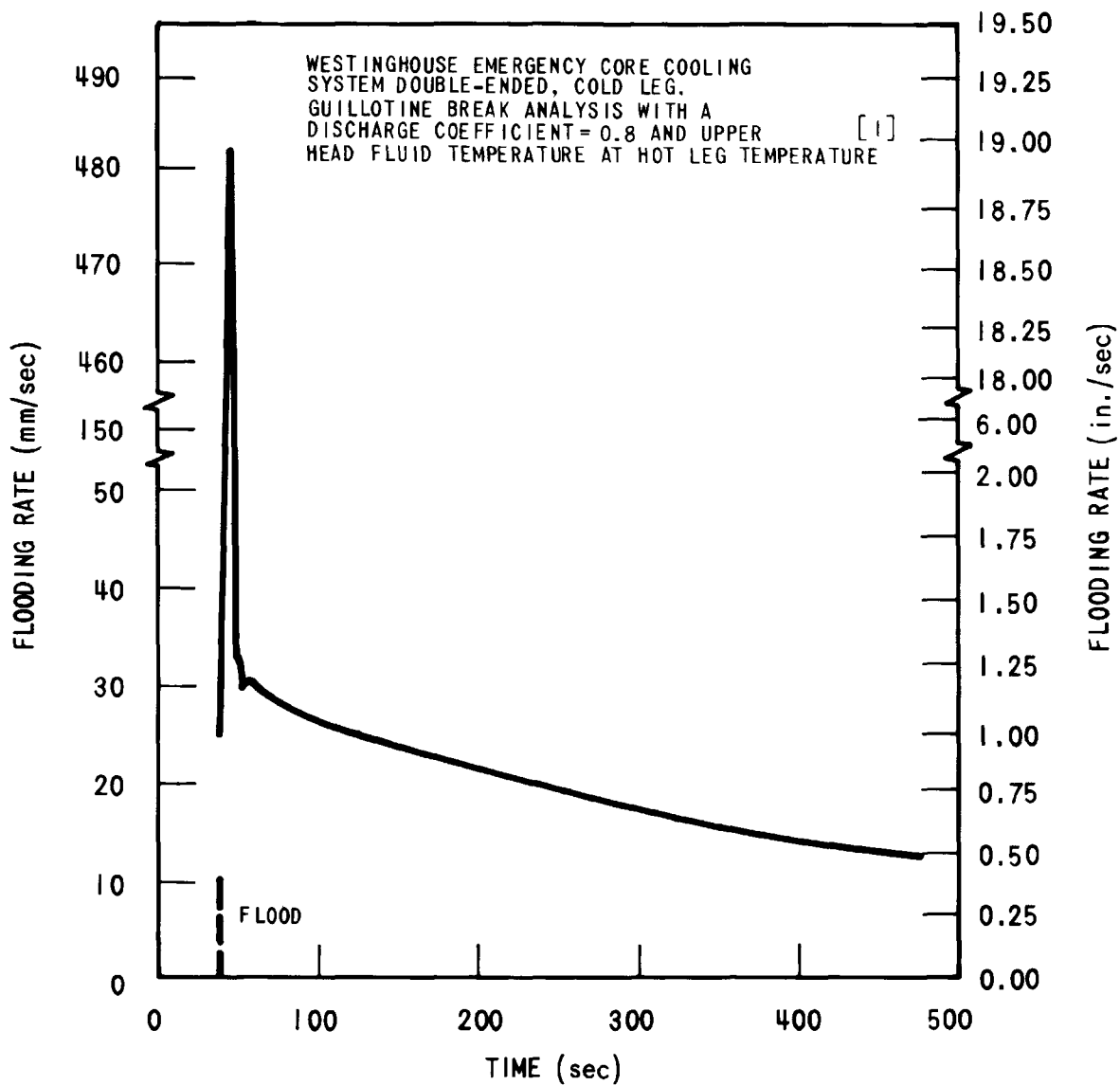

1. BECK, H. S. AND KEMPER, R. M., "WESTINGHOUSE ECCS - FOUR-LOOP PLANT (17 x 17) SENSITIVITY STUDIES WITH UPPER HEAD FLUID TEMPERATURES AT  $T_{HOT}$ ," WCAP-8365-A, MAY 1977.

Figure 8-2. Predicted Flooding Rate During Core Reflood of a Westinghouse PWR Dry Containment Plant

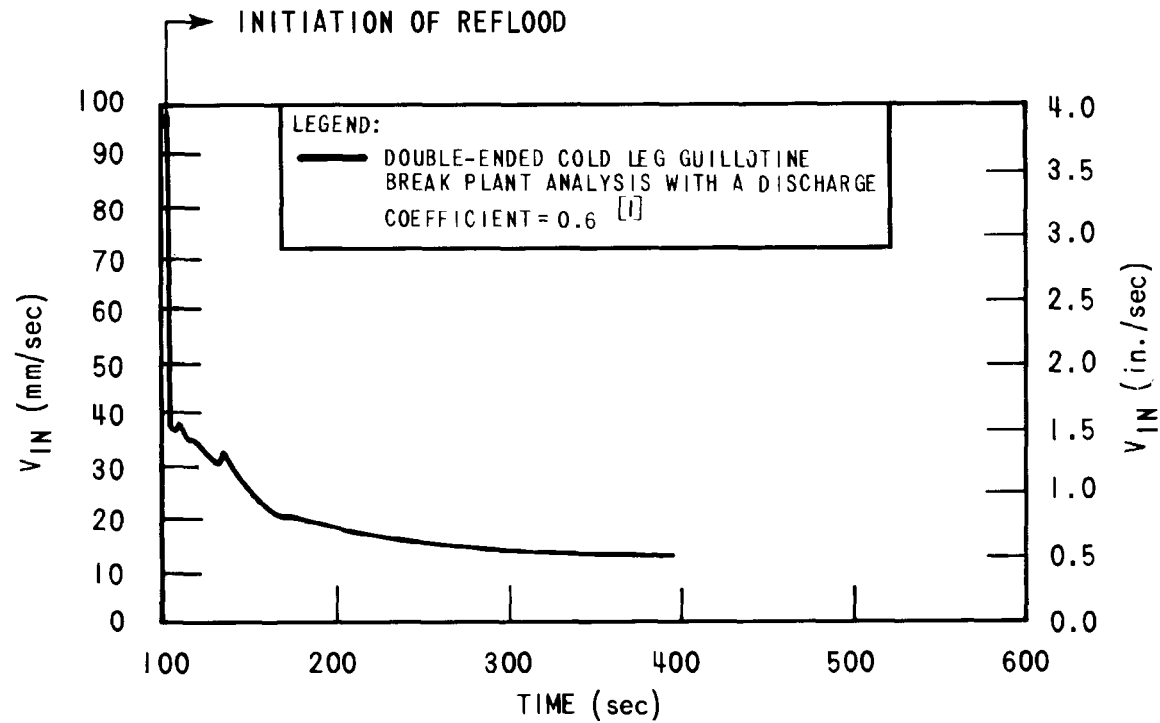

1. SEQUOYAH NUCLEAR POWER PLANT, FSAR AMENDMENT 50, JANUARY 31, 1978

Figure 8-3. Predicted Flooding Rate During Core Reflood of a Westinghouse Ice Condenser Plant

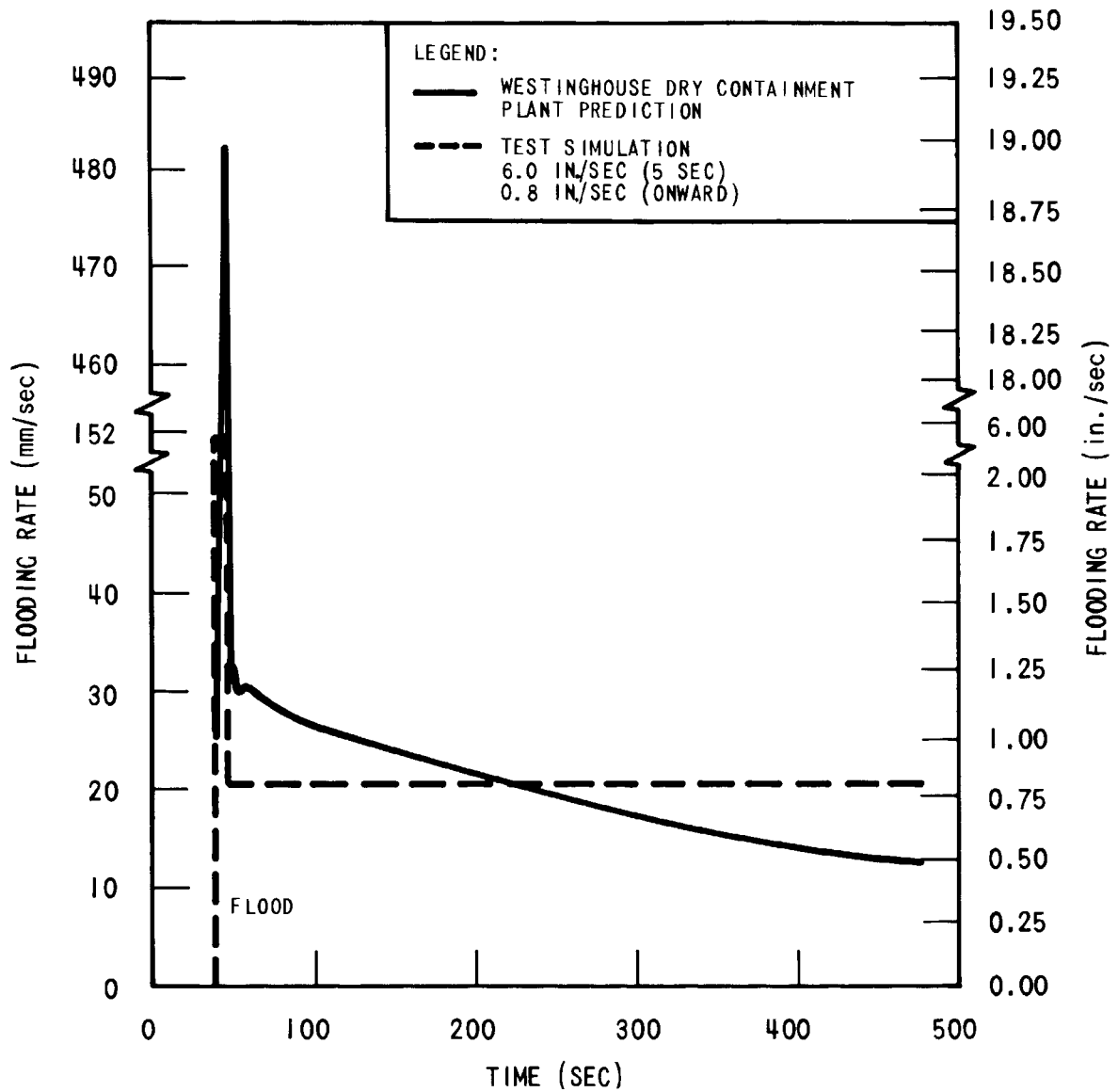

Figure 8-4. Variable Stepped Flow Simulation of Predicted Core Reflood of a Westinghouse PWR Dry Containment Plant (Two Steps)

## SECTION 9

# DATA REDUCTION, ANALYSIS, AND EVALUATION PLANS

### 9-1. DATA REDUCTION

The data to be analyzed in detail will be recorded on the PDP-11/20 computer at the Forest Hills, PA, test site, and then transferred to magnetic tape. The magnetic tape will then be processed at the Westinghouse Nuclear Center (Monroeville, PA) through a series of data reduction and analysis programs to obtain the necessary engineering data. The flow logic of the computer codes, which is identical to that in the unblocked bundle facility, is shown in figures 9-1 and 9-2. The different data reduction stages needed first to validate the test and then to evaluate the data are also shown. In this fashion only test data which are judged to be valid are fully reduced. The catalog tape for all tests, whether valid or invalid, is saved. Table 9-1 briefly describes the main function and the output for each data reduction and analysis code. New codes (for either data reduction or analysis) used in this task will be discussed in either the data or the evaluation reports. Details of each of the codes listed in table 9-1 are discussed in appendix E.

All data reduction and analysis codes are written in English engineering units. This system will be maintained and results of the calculations will be converted to metric units for presentation in reports.

### 9-2. DATA ANALYSIS AND EVALUATION

The data for this task will be evaluated and analyzed by procedures similar to those used for the unblocked bundle data<sup>(1)</sup> and 21-rod bundle data.<sup>(2)</sup> As part of the data

- 
1. Hochreiter, L. E., et al., "PWR FLECHT SEASET Unblocked Bundle, Forced and Gravity Reflood Task: Task Plan Report," NRC/EPRI/Westinghouse-3, March 1978.
  2. Hochreiter, L. E., et al., "PWR FLECHT SEASET 21-Rod Bundle Flow Blockage Task: Task Plan Report," NRC/EPRI/Westinghouse-5, March 1980.

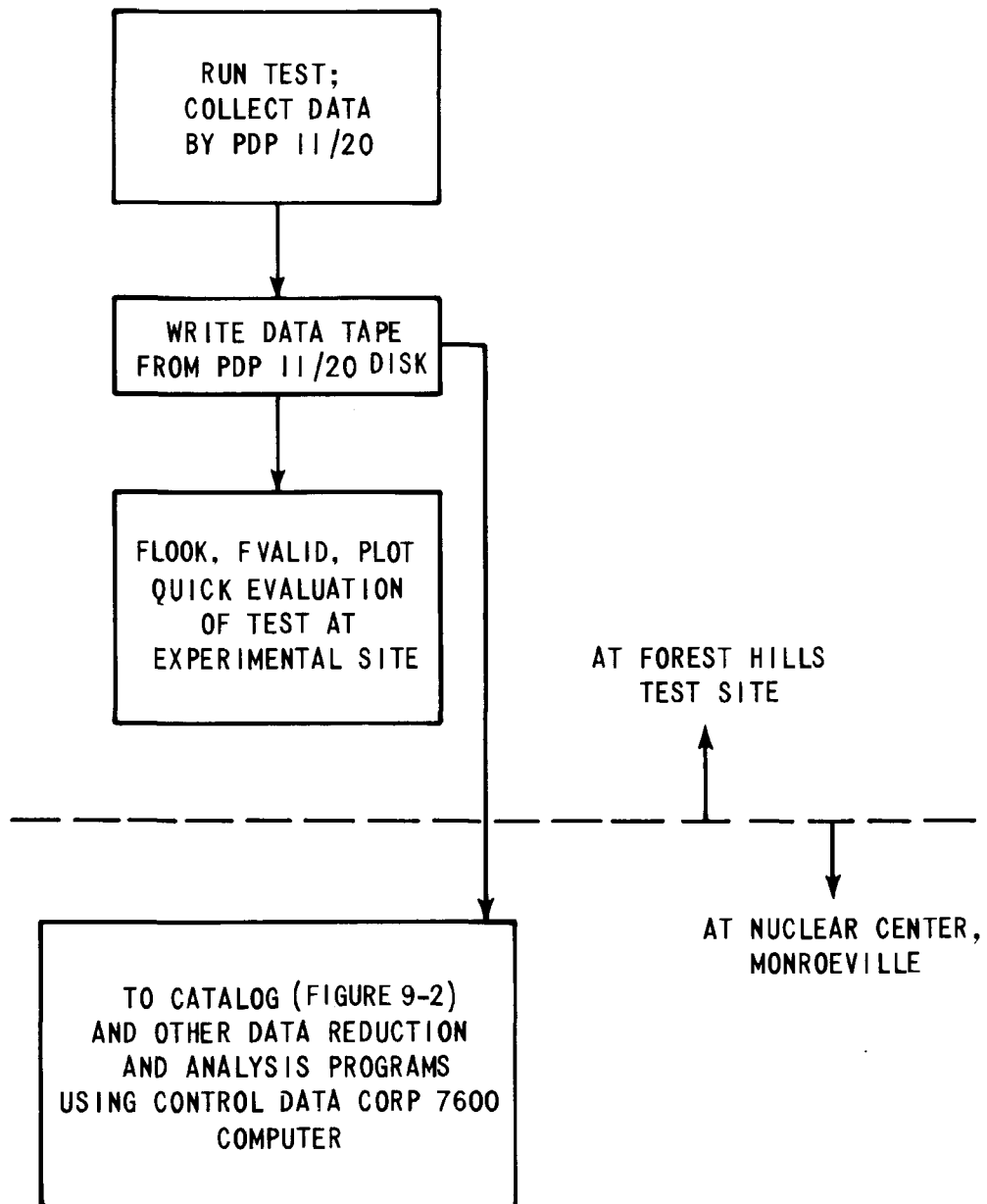

Figure 9-1. Flow Logic of Computer Codes

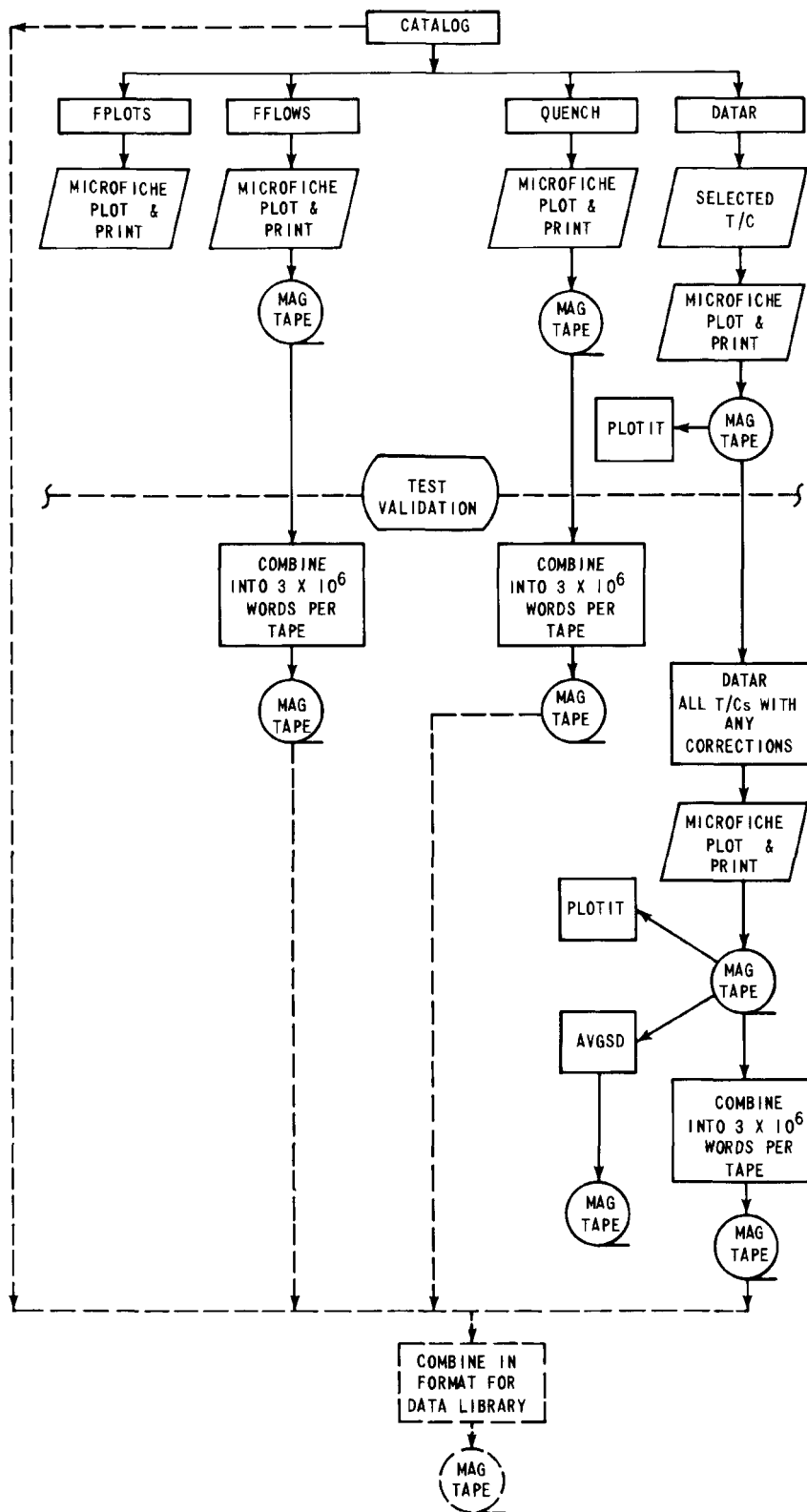

Figure 9-2. FLECHT SEASET Data Reduction Flow Chart

TABLE 9-1

DATA REDUCTION AND ANALYSIS  
COMPUTER CODES FOR FLOW BLOCKAGE TASK

Data Reduction Code	Main Function	Output	Units	
			Metric	English Engineering
CATALOG	Lists each data channel as a function of run time	Tables of data and time in engineering units: Time Temperature Pressure Differential pressure Flow Power	sec °C MPa MPa m <sup>3</sup> /sec kw	sec °F psia psig gal/min kw
FPLOTS	Plots each data channel as a function of time	Same as CATALOG	Same as CATALOG	Same as CATALOG
FFLOWS	Calculates overall mass balances, mass accumulation, and bundle exit rates	Two-phase pressure drop Void fraction Two-phase density Two-phase mass Two-phase frictional pressure drop Mass stored in bundle based on a) Overall differential pressure cells 0-3.66 m (0- 144 in.) b) Sum of incremental differential pressure cells  $\sum_{i=0}^{144} \Delta P_i$	MPa - kg/m <sup>3</sup> kg MPa  kg  kg	psid - lbm/ft <sup>3</sup> lbm psid  lbm

TABLE 9-1 (cont)

DATA REDUCTION AND ANALYSIS  
COMPUTER CODES FOR FLOW BLOCKAGE TASK

Data Reduction Code	Main Function	Output	Units	
			Metric	English Engineering
FFLOWS (cont)		Mass difference	kg	lbm
		Two-phase steam velocity	m/sec	ft/sec
		Time	sec	sec
		Accumulator mass loss	kg	lbm
		Mass injected		
		Total	kg	lbm
		Rate	kg/sec	lbm/sec
		Mass stored		
		Total	kg	lbm
		Rate	kg/sec	lbm/sec
		Mass out		
		Total	kg	lbm
		Rate	kg/sec	lbm/sec
		Mass difference		
		Total	kg	lbm
		Rate	kg/sec	lbm/sec
		Carryout fractions:		
		(a) Based on mass stored		
		Total	-	-
		Rate	-	-
(b) Based on mass out				
Total	-	-		
Rate	-	-		

TABLE 9-1 (cont)

DATA REDUCTION AND ANALYSIS  
COMPUTER CODES FOR FLOW BLOCKAGE TASK

Data Reduction Code	Main Function	Output	Units	
			Metric	English Engineering
FFLOWS (cont)		Test section mass		
		Total	kg	lbm
		Rate	kg/sec	lbm/sec
		Carryover tank mass		
		Total	kg	lbm
		Rate	kg/sec	lbm/sec
		Steam separator mass		
		Total	kg	lbm
		Rate	kg/sec	lbm/sec
		Exhaust orifice mass		
		Total	kg	lbm
		Rate	kg/sec	lbm/sec
		Overall mass balance	kg	lbm
Lower bound quality	-	-		
Upper bound quality	-	-		
Mass leaving each differential pressure increment	kg	lbm		
QUENCH	Determines time-temperature history for each rod thermocouple	Initial temperature	°C	°F
		Turnaround temperature	°C	°F
		Turnaround time	sec	sec
		Temperature rise	°C	°F
		Quench time	sec	sec
		Quench temperature	°C	°F

TABLE 9-1 (cont)

DATA REDUCTION AND ANALYSIS  
COMPUTER CODES FOR FLOW BLOCKAGE TASK

Data Reduction Code	Main Function	Output	Units	
			Metric	English Engineering
DATAR	Calculates local surface temperature, heat flux, and heat transfer coefficients for each rod thermocouple	Measured temperature Calculated surface temperature Heat flux Heat transfer coefficient	$^{\circ}\text{C}$ $^{\circ}\text{C}$ $\text{W}/\text{m}^2$ $\text{W}/\text{m}^2\text{-}^{\circ}\text{C}$	$^{\circ}\text{F}$ $^{\circ}\text{F}$ $\text{Btu}/\text{hr}\text{-ft}^2$ $\text{Btu}/\text{hr}\text{-ft}^2\text{-}^{\circ}\text{F}$
PLOTIT	Plots DATAR variables versus time	Plots of DATAR output	Same as DATAR	Same as DATAR
AVGSD	Statistical analysis of DATAR output	Mean, one standard deviation, maximum and minimum for rod temperature heat transfer coefficient and heat flux in specified bundle zones	Same as DATAR	Same as DATAR
FLEMB	Calculates local conditions and other quantities relevant to heat transfer	Mass flow Quality Enthalpy Vapor Reynolds number Nusselt number Radiative heat flux to vapor Void fraction Wall temperature Vapor temperature Hot rod heat flux Total integrated heat flow	$\text{kg}/\text{sec}$ - $\text{J}/\text{kg}$ - - $\text{W}/\text{m}^2$ - $^{\circ}\text{C}$ $^{\circ}\text{C}$ $\text{W}/\text{m}^2$ $\text{J}$	$\text{lbm}/\text{sec}$ - $\text{Btu}/\text{lbm}$ - - $\text{Btu}/\text{hr}\text{-ft}^2$ - $^{\circ}\text{F}$ $^{\circ}\text{F}$ $\text{Btu}/\text{ft}^2\text{-hr}$ $\text{Btu}$

TABLE 9-1 (cont)

DATA REDUCTION AND ANALYSIS  
COMPUTER CODES FOR FLOW BLOCKAGE TASK

Data Reduction Code	Main Function	Output	Units	
			Metric	English Engineering
ALLTURN (Z-Zq)	Calculates heat transfer coefficient based on distance above the quench front	Heat transfer coefficient as a function of elevation for a given time	W/m <sup>2</sup> -°C m sec	Btu/hr-ft <sup>2</sup> -°F ft sec
HEAT-II	Calculates components of heat transfer to entrained liquid and steam	Droplet diameter Droplet number density Droplet velocity Vapor velocity Slip ratio Void fraction Droplet Reynolds number Droplet Weber number Rod heat flux Surface-to-surface radiation heat flux Wall-to-vapor radiation heat flux Wall-to-droplet radiation heat flux Wall-to-vapor convective heat flux Vapor-to-droplet radiation heat flux Heat transfer coefficient Nusselt number Quality Steam temperature Wall temperature	m drops/m <sup>3</sup> m/sec m/sec - - - - W/m <sup>2</sup> W/m <sup>2</sup> W/m <sup>2</sup> W/m <sup>2</sup> W/m <sup>2</sup> W/m <sup>2</sup> W/m <sup>2</sup> W/m <sup>2</sup> -°C - - °C °C	ft drops/ft <sup>3</sup> ft/sec ft/sec - - - - Btu/ft <sup>2</sup> -hr Btu/ft <sup>2</sup> -hr Btu/ft <sup>2</sup> -hr Btu/ft <sup>2</sup> -hr Btu/ft <sup>2</sup> -hr Btu/ft <sup>2</sup> -hr Btu/hr-ft <sup>2</sup> -°F - - °F °F

TABLE 9-1 (cont)

DATA REDUCTION AND ANALYSIS  
COMPUTER CODES FOR FLOW BLOCKAGE TASK

Data Reduction Code	Main Function	Output	Units	
			Metric	English Engineering
HEAT-II (cont)		Normalized surface-to-surface radiation heat flux	-	-
		Normalized wall-to-droplet radiation heat flux	-	-
		Normalized wall-to-vapor radiation heat flux	-	-
		Normalized wall-to-vapor convective heat flux	-	-
		Vapor Reynolds number	-	-
		Optical thickness	mm	in.

evaluation process, the single-parameter trends in temperature rise, turnaround time, and quench time will be compared to see if trends found in these new data are consistent with previous FLECHT data. The data trends will be investigated for each test parameter such as pressure, flooding rate, power, initial clad temperature, and sub-cooling. In addition, heat transfer, clad temperature, and total mass carryout will be compared for each test parameter.

The special tests, such as the gravity reflood tests, will be examined separately to determine the effect of each test variation on the heat transfer, clad temperature, and total mass entrainment. In this fashion, qualitative statements can be made on the effect of each test parameter.

The entrainment and bundle void fraction data, also obtained from the experiments, will be compared to the semiempirical entrainment model developed in WCAP-8838.<sup>(1)</sup> Entrainment criteria such as superficial velocity or critical void fraction will also be investigated and compared with criteria in the literature.

In addition, the data will be analyzed to investigate heat transfer mechanisms occurring during reflood. The analytical methods developed in WCAP-9183<sup>(2)</sup> will be used to perform a mass and energy balance on the test bundle.

The bundle thermal-hydraulic parameters which will be calculated from the bundle mass and energy balance are given in table 9-2. Using these quantities, the measured wall heat flux will be divided into the individual heat transfer mechanisms using the HEAT-II computer code, which calculates the components of heat transfer to entrained liquid and steam, as noted in table 9-1. The HEAT-II program will give the radiation-to-vapor wall heat flux component, radiation to drops, radiation to other surfaces, and the resulting convective wall heat flux component. This approach will enable quantification of the different reflooding heat transfer mechanisms, which in turn will allow verification or development of mechanistic reflood heat transfer models. The analyzed

- 
1. Lilly, G. P., et al., "PWR FLECHT Cosine Low Flooding Rate Test Series Evaluation Report," WCAP-8838, March 1977.
  2. Lilly, G. P., et al., "PWR FLECHT Skewed Profile Low Flooding Rate Test Series Evaluation Report," WCAP-9183, November 1977.

TABLE 9-2

INFORMATION DERIVED FROM BASIC 161-ROD FLOW BLOCKAGE TASK DATA

Derived Thermal-Hydraulic Quantity	Method Used - Code	Location
Rod surface heat flux	Inverse conduction code - DATAR	At each rod thermocouple elevation
Heat transfer coefficient	Heat flux and rod surface and saturation temperatures - DATAR	At each rod thermocouple elevation
Bundle rod heat release rate	Bundle energy balance - FLEMB	Rod bundle heated length
Fluid mass storage rate	Test section mass balance - FFLOWS	Rod bundle
Effluent rate	Test section mass balance - FFLOWS	Exhaust orifice, carryover, and steam separator tank
Quench front velocity	Rod thermocouple quench data - QUENCH	Rod bundle heated length
Bundle axial void fraction	Momentum balance using different pressure readings corrected for frictional losses - FFLOWS	Rod bundle heated length

II-6

TABLE 9-2 (cont)

INFORMATION DERIVED FROM BASIC 161-ROD FLOW BLOCKAGE TASK DATA

Derived Thermal-Hydraulic Quantity	Method Used - Code	Location
Carryout fraction	Mass balance around test section - FFLOWS	Injection rates, mass storage, and exhaust liquid and steam measurements
Liquid entrainment rate	Mass balance around test section - FFLOWS	Carryover and steam separator collection tanks
Nonequilibrium quality	Mass and energy balance	Rod bundle at each steam probe location
Equilibrium quality	Mass and energy balance	Rod bundle at each steam probe location
Exit quality	From test section exit liquid and steam flow measurements - FFLOWS	Test section exhaust
Heat flow to droplets	From axial quality changes, mass flows, and two-phase flow temperatures - HEAT-II	Rod bundle at each steam probe location

TABLE 9-2 (cont)

INFORMATION DERIVED FROM BASIC 161-ROD FLOW BLOCKAGE TASK DATA

Derived Thermal-Hydraulic Quantity	Method Used - Code	Location
Convective heat flux to steam	From axial quality changes, mass flows, and two-phase flow temperatures - HEAT-II	Rod bundle at each steam probe location
Radiative heat flux to drops	From axial quality changes, mass flows, and two-phase flow temperatures - HEAT-II	Rod bundle at each steam probe location
Radiative heat flux to steam	From axial quality changes, mass flows, and two-phase flow temperatures - HEAT-II	Rod bundle at each steam probe location

data will also be compared with existing heat transfer correlations or models, and with the blockage heat transfer method developed in the 21-rod bundle task. The resulting information will also be presented in tabular form to enable correlation of the data in various ways.

The effect of different blockage configurations will be obtained by comparison between the different blocked bundle tests and the unblocked bundle tests. The instrumentation layout of both bundles will allow comparison of the transient wall temperature, FLECHT heat transfer coefficient, wall heat flux, and vapor temperature at several locations within and downstream of the blockage zone. These data can then be plotted against the test parameters (such as flooding rate and pressure) to determine whether any heat transfer decrease occurs over the test parameter range investigated. In addition, zones of either improved or degraded heat transfer downstream of the blockage region will be mapped out and normalized to the unblocked bundle data for each 161-rod blocked bundle configuration.

For the bypass flow blockage tests, data comparisons will allow the assessment of the flow redistribution effect on the heat transfer both in the blockage wake and in the flow bypass region. Comparisons will indicate the relative importance of the flow bypass effect to the droplet breakup effect as a function of the different test parameters. For the case of flow redistribution, the data will be analyzed in an approximate manner, since the flow will not be one-dimensional. The single-phase flow field will be calculated on a subchannel basis with the COBRA-IV code or other appropriate analyses to obtain the redistribution effects in the bundle. This calculation will be used with the measured data to estimate the local quality on the different sizes of the bundle and the quality behavior downstream of the blockage zone.

These calculations may be less accurate than the one-dimensional calculations for the unblocked bundle tests, since the flow redistribution behavior will be estimated by means of COBRA-IV. The flow behavior and the local fluid conditions calculated in this manner will be compared to similar calculations for the unblocked tests and the tests with uniform flow blockage. Thus, by comparing the fluid conditions such as quality, vapor Reynolds number,  $T_{\text{wall}}$ ,  $T_{\text{vapor}}$ , and the wall heat flux, the effect of the flow blockage on the rod heat transfer can be examined.

### 9-3. MECHANISTIC DATA ANALYSIS

During the course of experimentation in the 21-rod bundle task, a mechanistic model for flow blockage will be developed which will subsequently be assessed in the 161-rod bundle task.

At the present time, the easiest and most direct approach for analysis and correlation of the data appears to be a modification of an existing FLECHT-type correlation to account for both flow blockage effects and flow bypass.

As previously discussed in the program plan<sup>(1)</sup> and the 21-rod bundle task plan, an expression for the heat transfer downstream of a single blocked rod can be written, using the method of Hall and Duffey,<sup>(2)</sup> as

$$h_B = h_o \left( \frac{G_B}{G_o} \right)^m N_e \quad (9-1)$$

where

$G_B$  = single-phase flow rate, which can be obtained from a subchannel analysis code like COBRA-IV

$N_e$  = empirical blockage factor, which accounts for the effects of droplet atomization, increased turbulence, local flow acceleration, and slip between vapor and droplet caused by single-rod blockage. It is expected to be a function of the blockage shape.

$G_o$  = unblocked single-phase flow rate from COBRA-IV

1. Conway, C. E., et al., "PWR FLECHT Separate Effects and Systems Effects Test (SEASET) Program Plan," NRC/EPRI/Westinghouse-1, December 1977.
2. Hall, P. C., and Duffey, R. B., "A Method of Calculating the Effect of Clad Ballooning on Loss-of-Coolant Accident Temperature Transients," Nucl. Sci. Eng. 58, 1-20 (1975).

- $h_o$  = unblocked heat transfer coefficient
- $m$  = exponent of the flow, depending on the convective heat transfer, using a Dittus-Boelter correlation (typically  $m = 0.8$ )

Quantification of  $N_e$  will be obtained by analysis of the 21-rod bundle experiments for the different blockage shapes tested. In reality, the above equation becomes the defining equation for  $N_e$ . The blocked test series with no bypass will yield data to determine  $N_e$ , since  $(G_B/G_o)^m$  is equal to 1.

The blockage model developed from the 21-rod bundle task will be assessed through comparisons with the 161-rod blocked bundle data. For each 161-rod blocked bundle configuration, a COBRA-IV single-phase steam flow calculation will be performed to estimate the flow redistribution within the bundle. This single-phase calculation will give a value of  $G(z,x,y)/G_o$  for each position in each subchannel. The enhancement factor  $N_e$  will have been obtained from the 21-rod bundle task for this particular blockage shape. Using both of these pieces of information and the unblocked bundle heat transfer experience, the value of the blocked bundle heat transfer coefficient will be obtained. The resulting calculated value of the blocked bundle heat transfer will then be compared with the measured heat transfer to see how well the proposed model predicted the experiment. If the comparison is acceptable for the different blockage configurations, then blockage model improvement will be minimized. If the comparisons are less favorable, a refined approach may then be necessary.

#### 9-4. STATISTICAL DATA EVALUATION

The statistical data evaluation techniques discussed in the 21-rod bundle task plan will also be applied to the 161-rod bundle tests. The purpose of this data evaluation will be to statistically quantify the data bias caused by the combined effects of blockage and bypass. Flow blockage is another parameter which can promote bias and variation in the data which should be greater than other variations within the data. To properly assess the effect on heat transfer due to flow blockage, the blockage effect must be separable from these other variations.

The proposed statistical approach will establish the distributions of the unblocked heat transfer data and the blocked heat transfer data on a common basis, so that the effect of blockage can be obtained. Data means, standard deviations, and frequency distributions will be compared at each elevation as a function of time to ascertain the additional variation introduced by the blockage.

Each effect which could cause variation between a blocked rod in the blocked bundle and an unblocked rod in the unblocked bundle must be examined to establish the true effect of blockage. Those effects which can create variance in the FLECHT data are as follows:

- Uncertainty in the calculated heat transfer due to manufacturing differences and the measured heater rod temperature and power<sup>(1)</sup>
- Variation due to radial position within the bundle, which can result in local heat transfer being different from channel to channel
- Uncertainty of establishing repeatable test conditions
- Variation between the two bundles used
- Variation caused by the noncoplanar blockage on the local heat transfer in the bundle

To screen out the first four effects, suitable instrumentation and repeat tests will be necessary for both the unblocked bundle tests and the blocked bundle tests. This necessity has been examined in the unblocked test series and will be considered in the blocked bundle tests.

The instrumentation plan for the 161-rod bundle has been designed to provide data for examining the above five reasons for data variance. Similar instrumentation locations exist in the 161-rod blocked bundle and in the unblocked bundle. There is ample instrumentation at different radial locations to obtain any radial variation.

---

1. Rosal, E. R., et al., "FLECHT Low Flooding Rate Skewed Test Series Data Report," WCAP-9108, May 1977.

In addition, the azimuthal location of the thermocouples is also being specified in the 161-rod bundle, again to determine sources of data variance. Tests have been shown to be repeatable in previous FLECHT test series, and repeat tests within each test series of the 161-rod bundle are planned. The bundle-to-bundle variation can be examined by comparing the data at elevations below the blockage zone for similar tests with different bundles. In these comparisons, two sources of variance would be present: bundle-to-bundle difference and test-to-test difference. Since the facility loop design, controls, and associated instrumentation are the same for all test series, the test-to-test variance should be quantified by the repeat tests in each test series. Therefore, the additional variance due to bundle-to-bundle effects should be separable if it is significant.

By performing the heater rod error analysis described in WCAP-9108, appendix B, the uncertainty due to rod manufacturing effects, power measurements, and thermocouple error can be calculated. The repeat tests to be conducted in each test series will give the uncertainty due to fixing the bundle test conditions. It is expected that the slight differences in actual test conditions between the paired blocked and unblocked tests can be accounted for by adjusting the unblocked data by deterministic methods or using the results of unblocked tests. The bundle-to-bundle variation between the blocked bundle and the unblocked bundle will be obtained by comparing the thermocouple variation for "identical tests" at elevations away from the blockage plane, for example, at 1.2 m (4 ft).

Since these uncertainties can be determined, the resulting unknown variations which would exist in the heat transfer data would be the rod-to-rod heat transfer variation for the unblocked data and the local effect of blockage for the blocked bundle test. Statistical tests will be performed on the data to identify the parent population distribution from the data sample distribution. These resulting distributions will then be compared, as shown in figure 9-3. Such curves will be generated at different elevations for different times of interest so that the effect of the blockage on the heat transfer can be evaluated. One such elevation dependence curve is shown schematically in figure 9-4. To generate the distributions for the heat transfer data, some data pooling may be necessary, or additional assumptions on normality of the parent distributions

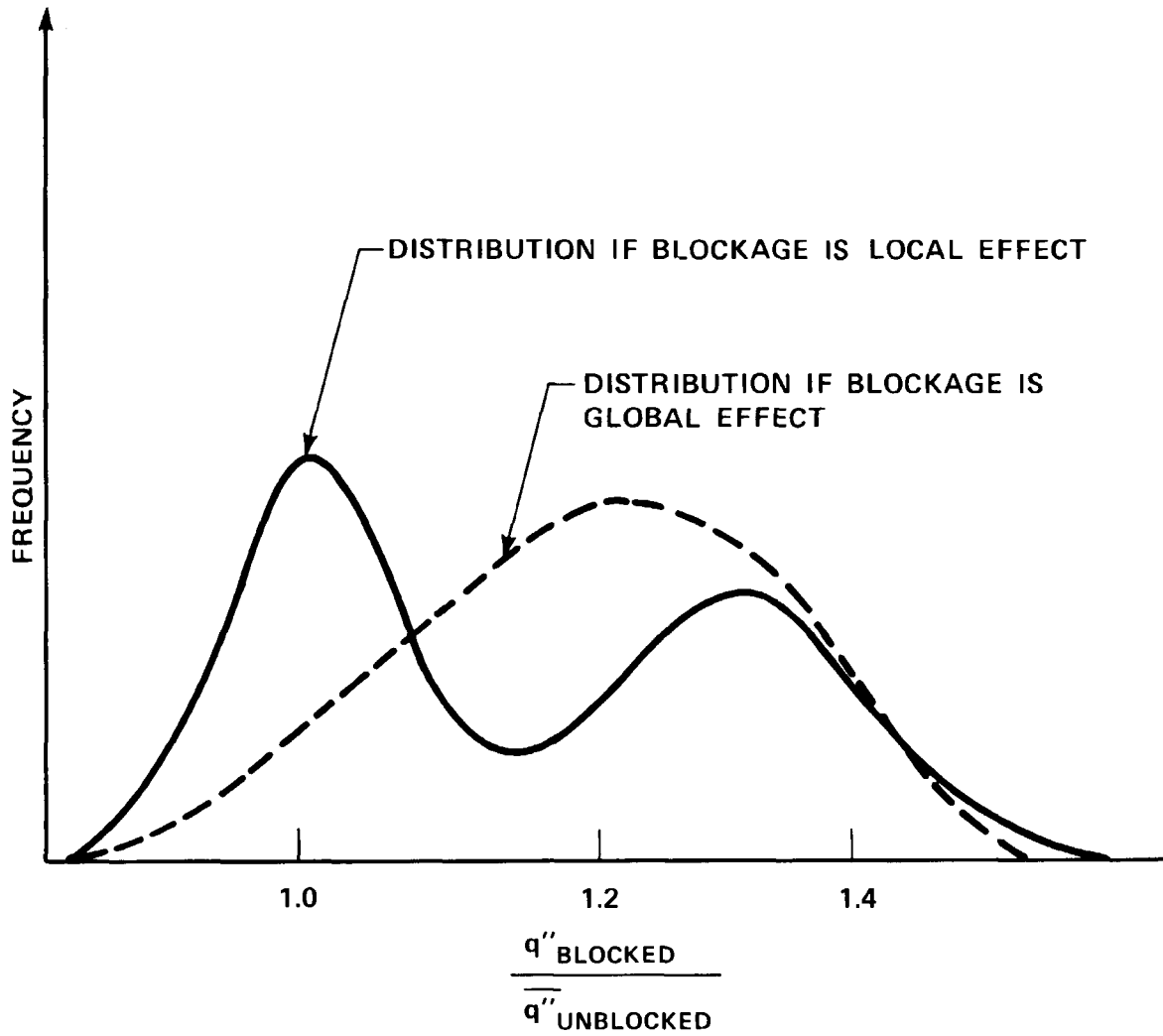

Figure 9-3. Sample Distribution Plots

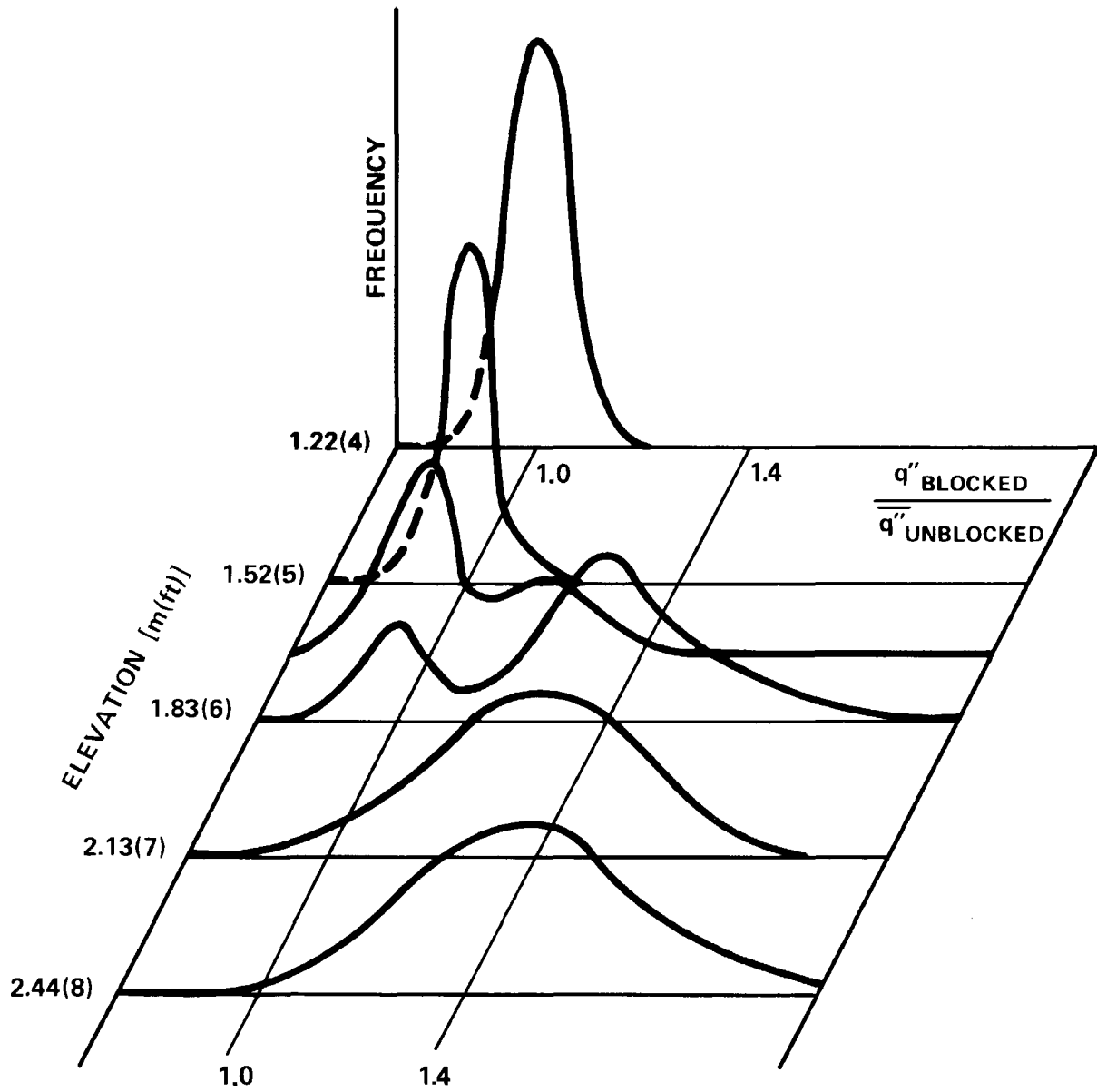

Figure 9-4. Sample Frequency Distribution Plots at Different Elevations for a Given Time

may be required. Instrumentation has been planned and provided in the bundle so that these assumptions can be confirmed for a few tests, and then applied for other tests.

Similar comparisons will also be performed with the blocked tests with bypass. In this case, results of the blocked tests with bypass and the blocked tests without bypass will be compared to assess the effects of bypass on the blocked heat transfer. The bypass test results will also be compared to the unblocked test results to obtain the total effect of the flow blockage with bypass relative to the unblocked geometry.

The end result of this data evaluation will be the assessment of the effect of blockage, both with and without flow bypass, relative to the unblocked data, with the only variations in the data caused by rod position, flow blockage at different rod positions, and flow bypass. Comparison of the generated frequency distribution plots should indicate the variations of the data means and the relative position of the tails of the frequency distributions. If the data indicate that the means for the blocked data are greater than those for the unblocked data, and that the distribution tails are within the distribution tails of the unblocked data, then clearly flow blockage does not degrade heat transfer relative to unblocked FLECHT data, since no negative variance has been introduced into the data by the blockage. If the frequency distributions indicate that the means of the blocked data are greater than those of the unblocked data, but the tails of the blockage distribution data yield lower heat transfer than the tails of the unblocked data, then these data will be investigated more closely to see if there is a thermal-hydraulic explanation for this trend. If a thermal-hydraulic explanation can be found, then this particular effect would be included in a model for flow blockage.

In summary, the combination of the statistical data evaluation and the deterministic data analysis should provide sufficient tools to explain the effect of the flow blockage on the resulting bundle heat transfer from a mechanistic viewpoint. If the resulting blocked bundle heat transfer is observed to always be a heat transfer benefit relative to the unblocked data, the proposed analytical methods should be able to explain why. If the blockage heat transfer is found to be a penalty relative to the unblocked heat transfer, the proposed analytical methods should provide the explanation of why a penalty results.

9-22

## **SECTION 10 TASK SCHEDULE**

Table 10-1 is a list of the major milestones for this task; figure 10-1 presents a more detailed task schedule. The critical item is completion of the 21-rod bundle testing and the blockage sleeve selection.

TABLE 10-1

## MAJOR MILESTONES FOR FLECHT SEASET 161-ROD BLOCKED BUNDLE TASK

Milestone No.	Milestone	Months After Contract Start Date <sup>(a)</sup>	Calendar Date
E1	Initiate test planning and facilitate design	19	2/1/79A <sup>(a)</sup>
E2	Issue draft task plan for review	29	12/1/79
E3	Complete facility design and major loop procurement, initiate construction	33.5	4/15/80
E4	Initiate blockage sleeve procurement (constrained by milestone F8 of 21-rod task)	45.5	4/15/81
E5	Complete facility construction and initiate shakedown testing	50.5	9/15/81
E6	Complete shakedown testing	53.0	12/1/81
E7	Complete two test series and one bundle changeover	61.0	8/1/82
E8	Complete draft data report	64.0	11/1/82
E9	Complete draft data analysis and evaluation report	67.0	2/1/83

a. A - actual date

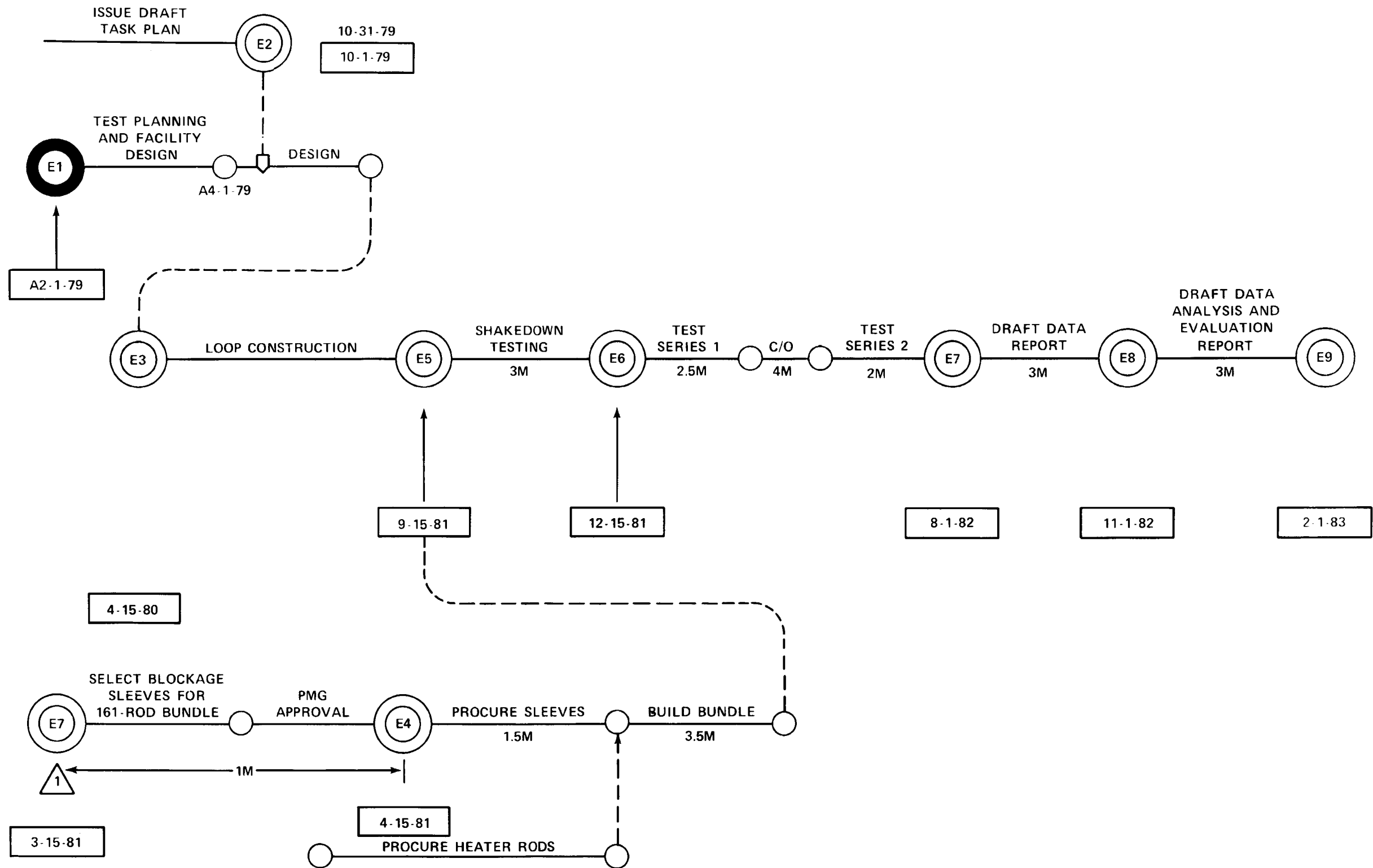

A = ACTUAL

Figure 10-1. Task Schedule for FLECHT SEASET 161-Rod Bundle Heat Transfer Task



## APPENDIX A WORK SCOPE

The following describes the work scope and objectives of the 161-rod bundle forced and gravity reflood task (Task 3.2.3).

### A-1. OBJECTIVE

The objective is to provide a data base which can be compared with the data from Task 3.2.1 and existing FLECHT tests to assess the effects of blockage on reflood heat transfer and entrainment. This task will use the blockage shape identified from the 21-rod bundle task (Task 3.2.2).

### A-2. SCOPE

The scope of the program is as follows:

- (1) Prepare a task plan per section 4.0 of the contract work scope,<sup>(1)</sup> including the results of a study using a statistical analysis method to determine the distribution and the amount of flow blockage. This study will use information from analyses of PWR reactor vendors to define the blockage distribution which will be the reference case for the 161-bundle test.
- (2) Design, procure, and construct a test facility to provide for forced and gravity reflood tests to permit comparisons with unblocked tests.
- (3) Design and procure blockage sleeves.
- (4) Design and procure CRG heater rods with a cosine axial power profile.

---

1. Conway, C. E., et al., "PWR FLECHT Separate Effects and Systems Effects Test (SEASET) Program Plan," NRC/EPRI/Westinghouse-1, December 1977, appendix B.

- (5) Perform system calibration, instrumentation calibration, facility checkout, and facility shakedown tests.
- (6) Perform pretest predictions of selected large blocked bundle tests using the analytical and/or experimental methods developed in Task 3.2.2. Distribution of the predictions will be made in advance of the tests to members of the PMG.
- (7) Perform agreed-upon tests.
- (8) Review and validate test data.
- (9) Reduce the data to obtain heater rod temperature histories (including detailed clad temperature history downstream of the blockage), fluid temperature histories (including detailed measurements downstream of the blockage zone and in the bypass region), and the other thermal-hydraulic parameters that are described in paragraph 3.2.3 of the contract work scope, item 8.
- (10) Process and store transducer data on computer tapes.
- (11) Prepare a data report per section 4.0 of the contract work scope.
- (12) Provide derived thermal-hydraulic quantities and bundle average fluid conditions at several axial positions from the test data (vapor temperatures, local rod heat fluxes, rod to rod radiation, local heat transfer coefficients, bundle heat release rates, fluid mass storage, mass flow in, effluent rate from the test section, quench front velocities, and void fractions), where applicable. For the calculation of the thermal-hydraulic quantities, existing computer codes (such as COBRA) will be used. Evaluate the difference between the unblocked data of Task 3.2.1 and the flow blockage data.
- (13) Identify the two-phase flow regimes occurring during reflood using photographic methods and appropriate data. Identify probable heat transfer regimes and mechanisms that occur during the reflooding process. Evaluate the methods

developed in Task 3.2.2 using the data obtained in this task and modify the method if appropriate. From the data evaluation and analysis efforts, assess the effect of flow blockage on reflood heat transfer.

- (14) Prepare a data analysis and evaluation report per section 4.0 of the contract work scope.

A-4

## **APPENDIX B FACILITY DRAWINGS**

Drawings applicable to the 161-rod blocked bundle task are listed in table B-1. Those drawings not included in sections 6 and 7 are reproduced on the following pages.

TABLE B-1  
LIST OF DRAWINGS FOR FLECHT SEASET 161-ROD BLOCKED BUNDLE TASK

Drawing and Figure No.	Sub	Sheet	Title
1546E96, Figure 6-1	1	1	FLECHT SEASET 161-Rod Blocked Bundle Flow Diagram
Figure 6-2			FLECHT SEASET 161-Rod Blocked Bundle Test Section Assembly
1546E63, Figure 6-3	1	1	FLECHT SEASET 161-Rod Blocked Bundle Low Mass Housing
Figure 6-5			FLECHT SEASET Heater Rod Design
1462E99, Figure 7-9			FLECHT SEASET 161-Rod Blocked Bundle Instru- mentation Schematic Diagram
1550E55, Figure B-1	1	2	FLECHT SEASET 161-Rod Blocked Test Facility Layout
1546E74, Figure B-2			FLECHT SEASET 161-Rod Blocked Bundle Facility Upper Plenum
1546E75, Figure B-3			FLECHT SEASET 161-Rod Blocked Bundle Facility Lower Plenum
1546E92, Figure B-4			FLECHT SEASET 161-Rod Blocked Bundle Facility Carryover Tank
1546E89, Figure B-5			FLECHT SEASET 161-Rod Blocked Bundle Downcomer and Crossover Leg Piping
1546E76, Figure B-6			FLECHT SEASET 161-Rod Blocked Bundle Facility Housing Lateral Brace
1546E99 Figure B-7			FLECHT SEASET 161-Rod Blocked Bundle Piping Details

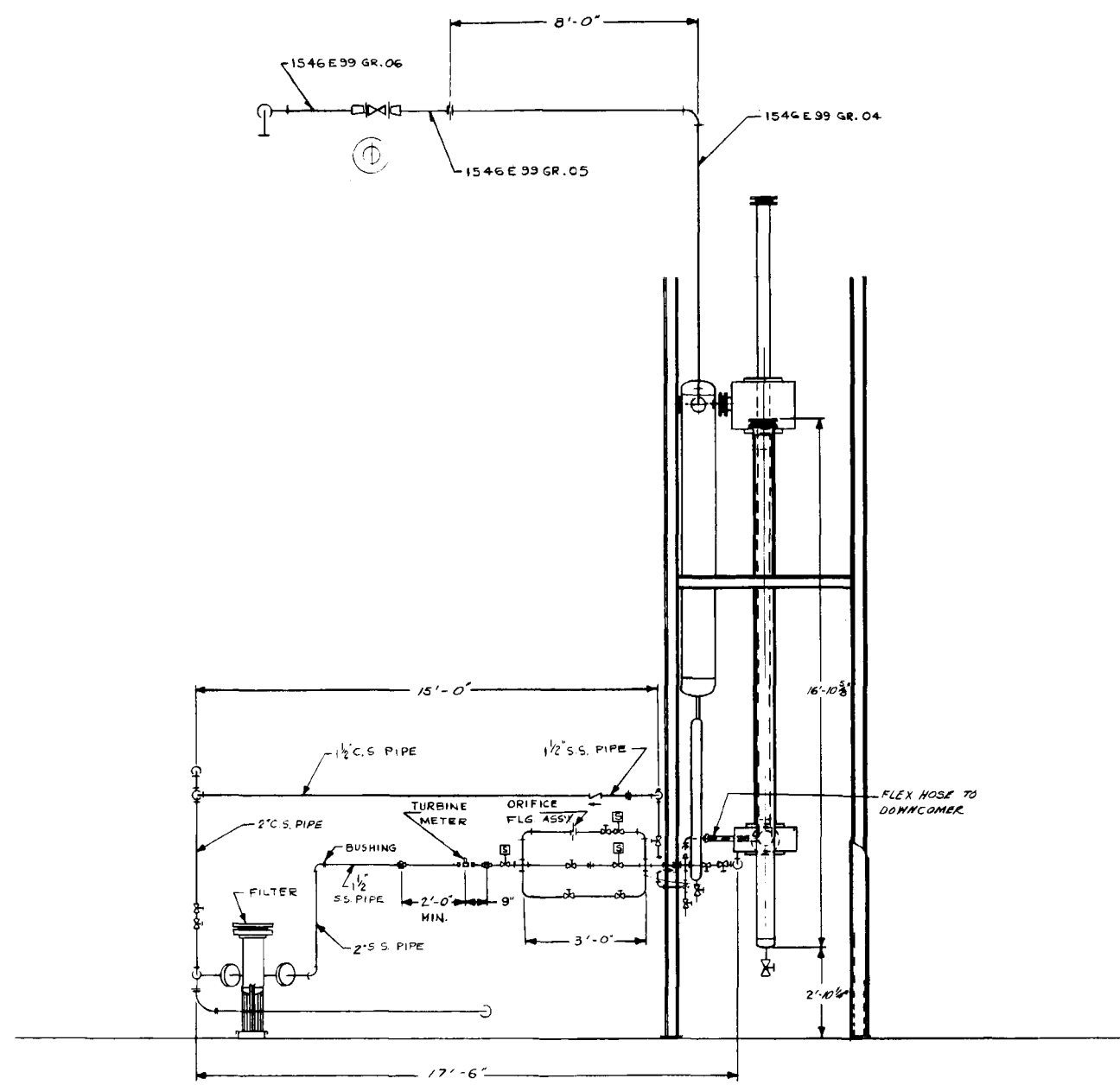
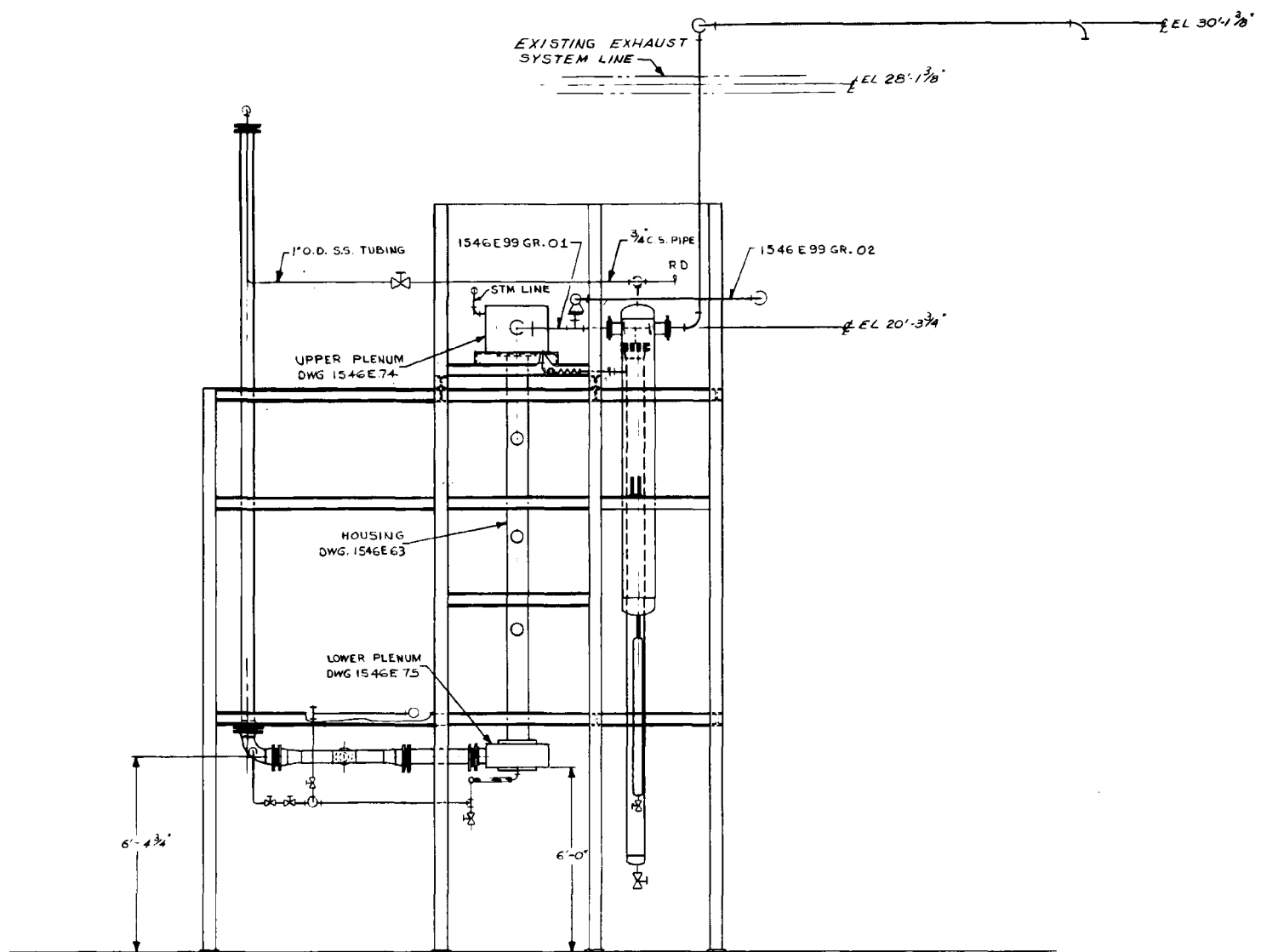

Figure B-1. FLECHT SEASET 161-Rod Blocked Bundle Test Facility Layout



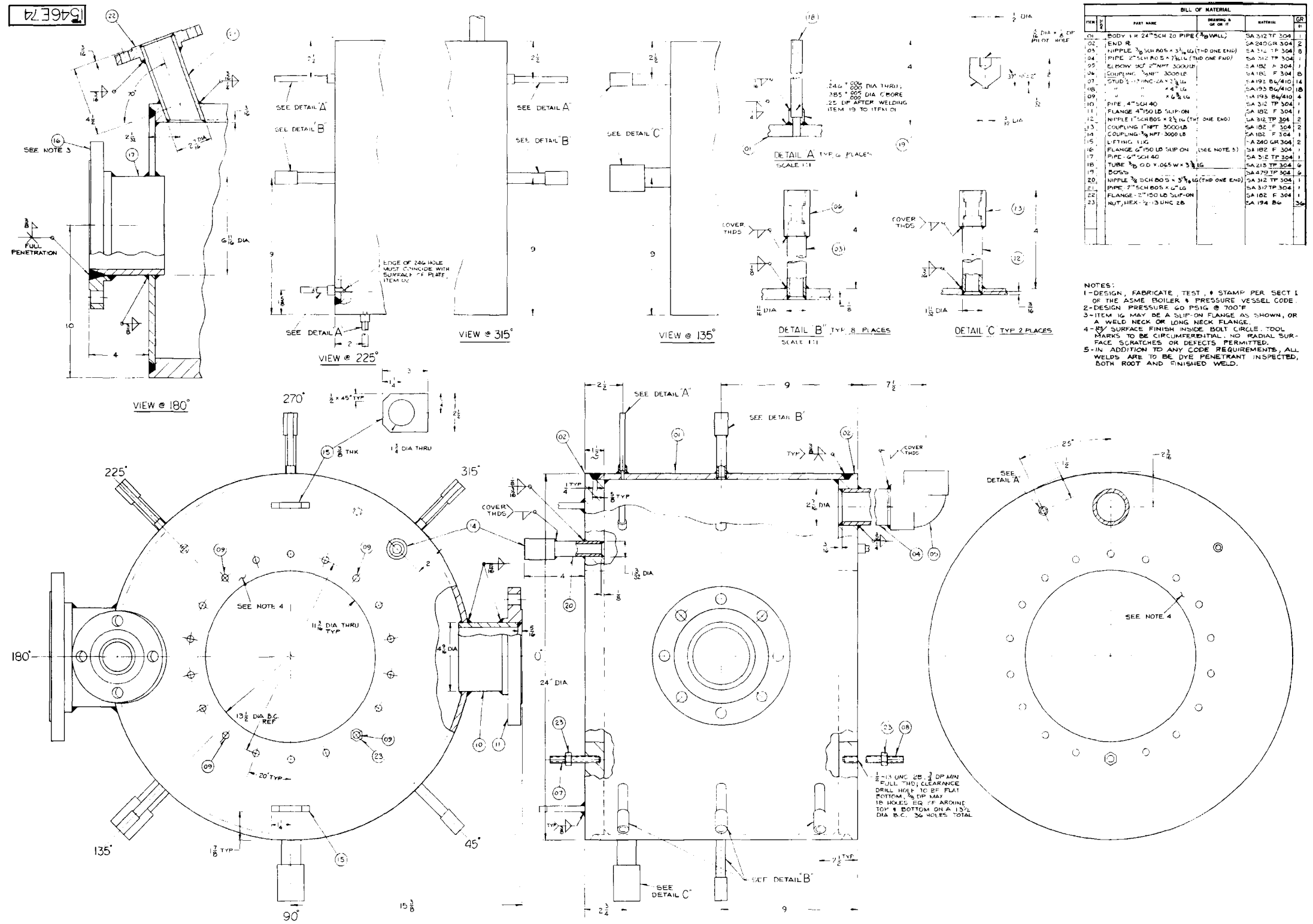
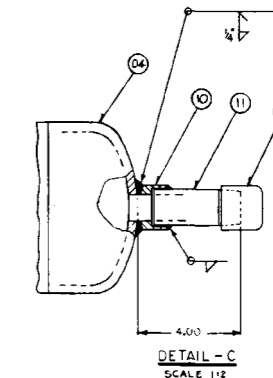
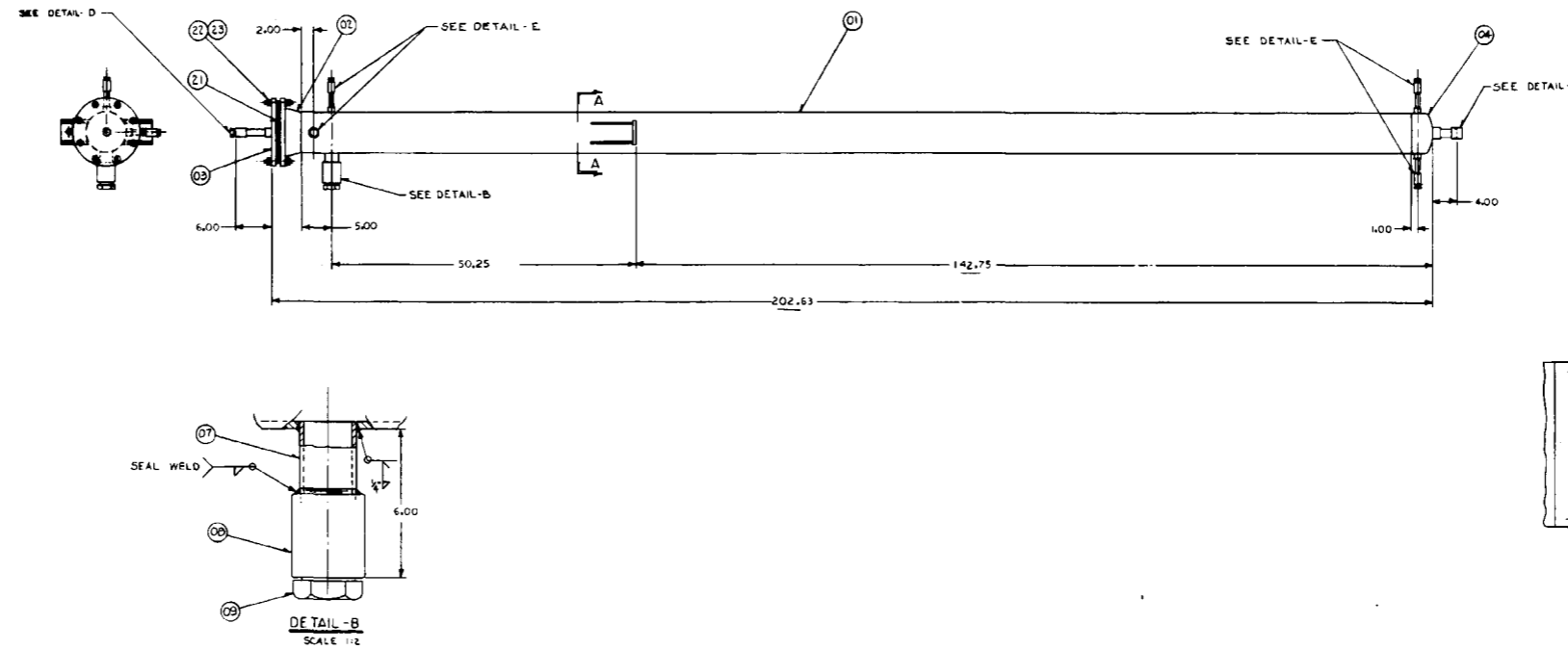
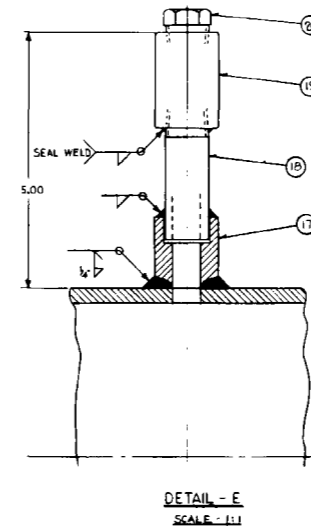
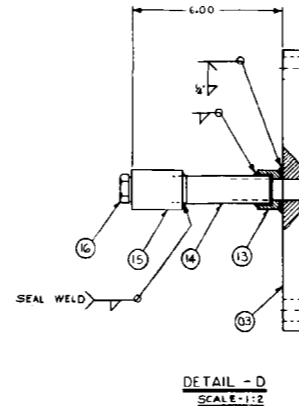
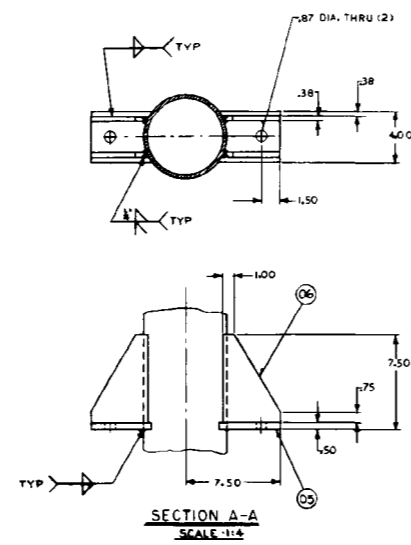

Figure B-2. FLECHT SEASET 161-Rod Blocked Bundle Facility Upper Plenum









BILL OF MATERIAL					
ITEM NO.	PART NAME	QUANTITY	MATERIAL	REQ. PER GROUP	GROUP
01	6" STD WT SEAMLESS PIPE	1	SA 106 B		
02	6" 150# 3/4" FLANGE	1	SA 105		
03	6" 150# BLIND FLANGE	1	SA 105		
04	6" STD WT WELD CAP	1	SA 2 3/4 WB		
05	2" x 4" x 1/2" PLATE	2	SA 36		
06	1/2" x 6" x 7" PLATE	4	SA 36		
07	2" STD WT SCR COUPLING	1	SA 106 B		
08	2" 2000# SCR COUPLING	1	SA 105		
09	2" TND PLUG	1	SA 105		
10	1" 3000# 3/4" HALF COUPLING	1	SA 105		
11	1" x 5/8" PIPE	1	SA 106 B		
12	1" 2000# TND CAP	1	SA 105		
13	3/4" 3000# 3/4" HALF COUPLING	1	SA 105		
14	1/2" x 5/8" PIPE	1	SA 106 B		
15	3/4" 3000# SCR COUPLING	1	SA 105		
16	3/4" 3000# TND PLUG	1	SA 105		
17	1/2" 3000# 3/4" HALF COUPLING	4	SA 105		
18	1/2" x 5/8" PIPE	4	SA 106 B		
19	1/2" 3000# TND COUPLING	4	SA 105		
20	1/2" 3000# TND PLUG	4	SA 105		
21	A FLEXITALLIC GASKET STYLE CO-77P	1			
22	1/2" x 5/8" STUDS	8	SA 193 B B7		
23	3/4" NUTS	8	SA 193 B 2 H 1G		

A-B-O FR FLEXITALLIC GASKET CO, CAMDEN, NEW JERSEY, 08102

NOTES:

1. THE ASSEMBLY IS TO BE DESIGNED, FABRICATED, TESTED, AND STAMPED IN ACCORDANCE WITH SECTION I OF THE ASME BOILER AND PRESSURE VESSEL CODE.
2. DESIGN PRESSURE - 100 PSI  
DESIGN TEMPERATURE - 700°F
3. TOLERANCE ON DIMENSIONS ±.125 UNLESS OTHERWISE SPECIFIED.
4. AS A MINIMUM, ALL WELDS SHALL BE DXE PENETRANT INSPECTED, BOTH ROOT AND FINISHED WELD.

Figure B-4. FLECHT SEASET 161-Rod Blocked Bundle Facility Carryover Tank



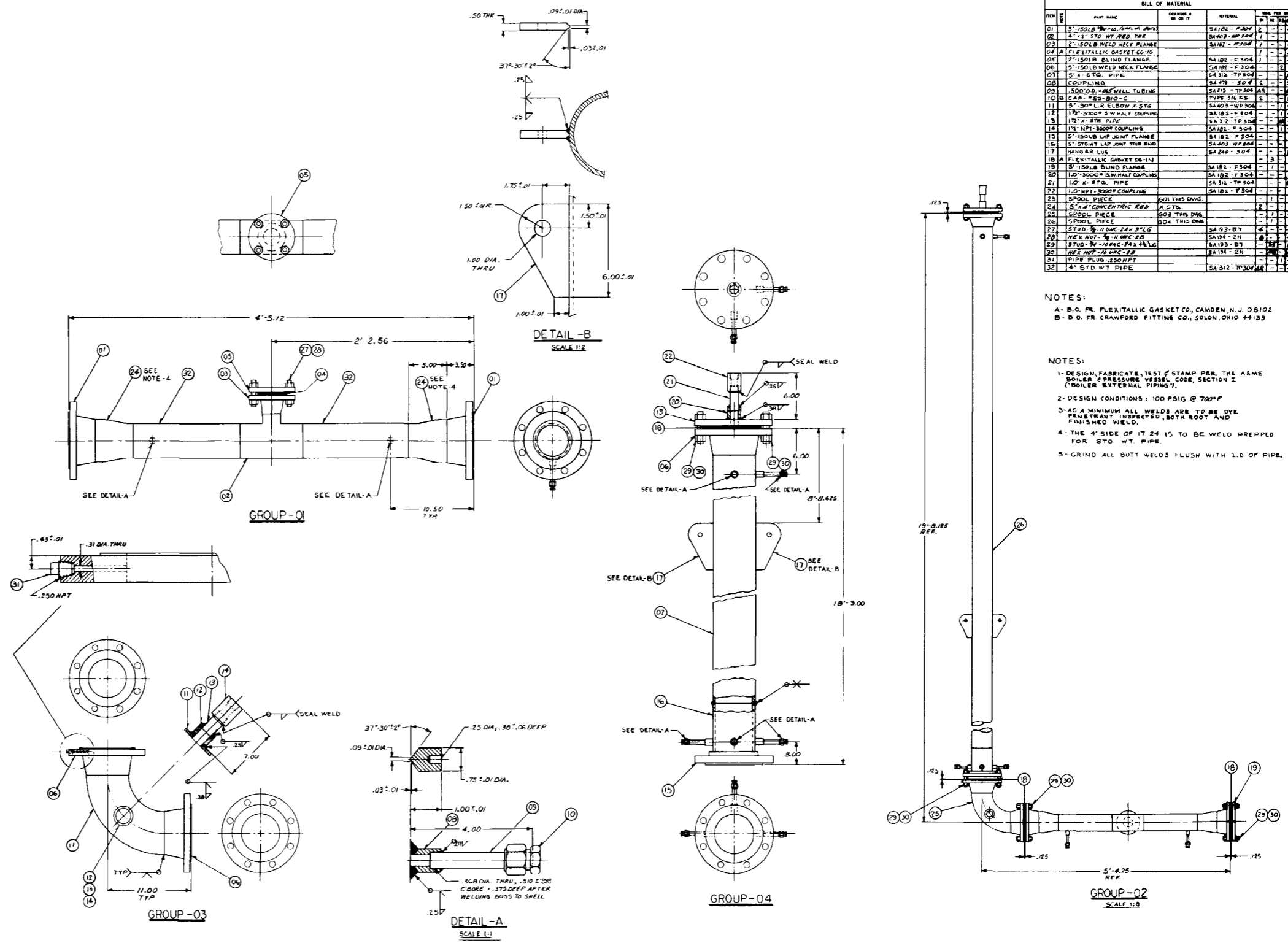

BILL OF MATERIAL					
ITEM	QTY	PART NAME	QUANTITY	MATERIAL	UNIT
01	1	5" SOLB WELD NECK FLANGE	SA182 - F304	2	
02	1	4" STD WT REG PIPE	SA403 - WP304	1	
03	1	2" SOLB WELD NECK FLANGE	SA182 - F304	1	
04	1	FLEXITALLIC GASKET CO-115		1	
05	1	2" SOLB BLIND FLANGE	SA182 - F304	1	
06	1	5" SOLB WELD NECK FLANGE	SA182 - F304	1	
07	1	5" X 6 TIG PIPE	SA312 - TP304	1	
08	1	COUPLING	SA403 - WP304	1	
09	1	500.00 IN WALL TUBING	SA213 - TP304	1	
10	1	CAP - 5/8 - 3/16 - C	TYPE 316 SS	1	
11	1	5" 30° L R ELBOW X STD	SA403 - WP304	1	
12	1	1 1/2" 3000# SW HALF COUPLING	SA182 - F304	1	
13	1	1 1/2" X STD PIPE	SA312 - TP304	1	
14	1	1 1/2" NPT-3000# COUPLING	SA182 - F304	1	
15	1	5" SOLB LAP JOINT FLANGE	SA182 - F304	1	
16	1	5" STD WT LAP JOINT SUB END	SA403 - WP304	1	
17	1	HANGER LUG	SA312 - F304	1	
18	1	FLEXITALLIC GASKET CO-115		1	
19	1	5" SOLB BLIND FLANGE	SA182 - F304	1	
20	1	1 1/2" 3000# SW HALF COUPLING	SA182 - F304	1	
21	1	1 1/2" X STD PIPE	SA312 - TP304	1	
22	1	1 1/2" NPT-3000# COUPLING	SA182 - F304	1	
23	1	SPOOL PIECE	Q04 THIS DWG	1	
24	1	5" X 6 CONCENTRIC RED X STD		1	
25	1	SPOOL PIECE	Q02 THIS DWG	1	
26	1	SPOOL PIECE	Q04 THIS DWG	1	
27	1	STD 3/4 UNF-2H-3/4 LG	SA193 - B7	1	
28	1	HEX NUT 3/4 UNF-2H	SA193 - B7	1	
29	1	STD 3/4 UNF-2H-3/4 LG	SA193 - B7	1	
30	1	HEX NUT 3/4 UNF-2H	SA193 - B7	1	
31	1	PIPE PLUG-150NPT		1	
32	1	4" STD WT PIPE	SA312 - TP304	1	

- NOTES:
- A - B.G. FR. FLEXITALLIC GASKET CO., CAMDEN, N.J. 08102
  - B - B.G. FR. CRAWFORD FITTING CO., SOLOM, OHIO 44139
- NOTES:
- 1- DESIGN, FABRICATE, TEST & STAMP PER THE ASME BOILER & PRESSURE VESSEL CODE, SECTION I ("BOILER EXTERNAL PIPING").
  - 2- DESIGN CONDITIONS: 100 PSIG @ 700°F
  - 3- AS A MINIMUM ALL WELDS ARE TO BE DYE PENETRANT INSPECTED, BOTH ROOT AND FINISHED WELD.
  - 4- THE 4" SIDE OF IT. 24 IS TO BE WELD PREPPED FOR STD. WT. PIPE
  - 5- GRIND ALL BUTT WELDS FLUSH WITH I.D. OF PIPE.

Figure B-5. FLECHT SEASET 161-Rod Blocked Bundle Downcomer and Crossover Leg Piping



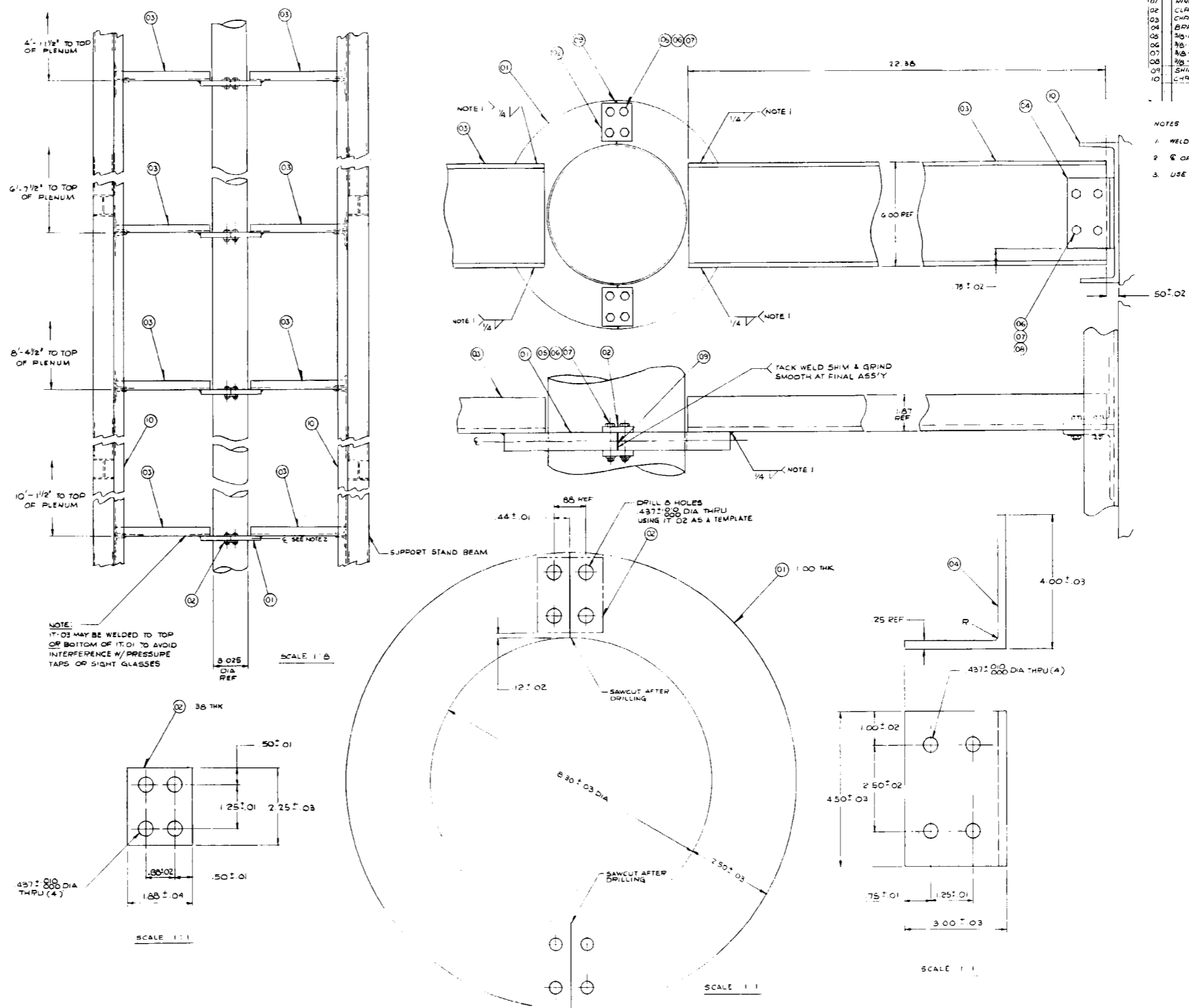

BILL OF MATERIAL							
ITEM	QTY	PART NAME	DRAWING # OR OR IT	MATERIAL	REQ. FOR SHOP		
					QTY	WT	LN
01		RING		C STL	4		
02		CLAMP		C STL	16		
03		CHANNEL 6 00 92971 X 22 38 18		C STL	8		
04		BRACKET		C STL	16		
05		3/8\"/>					
06		3/8\"/>					
07		3/8\"/>					
08		3/8\"/>					
09		SHIM		C STL	8		
10		CHANNEL 8 00 11571 X 17 1/2 28		C STL	2		

- NOTES
- WELD AT FINAL ASSEMBLY.
  - Q OF IT'S 01 SHOULD COINCIDE W/Q OF GRID.
  - USE IT 04 AS GUIDE FOR DRILLING IT 03.

Figure B-6. FLECHT SEASET 161-Rod Blocked Bundle Facility Housing Lateral Brace



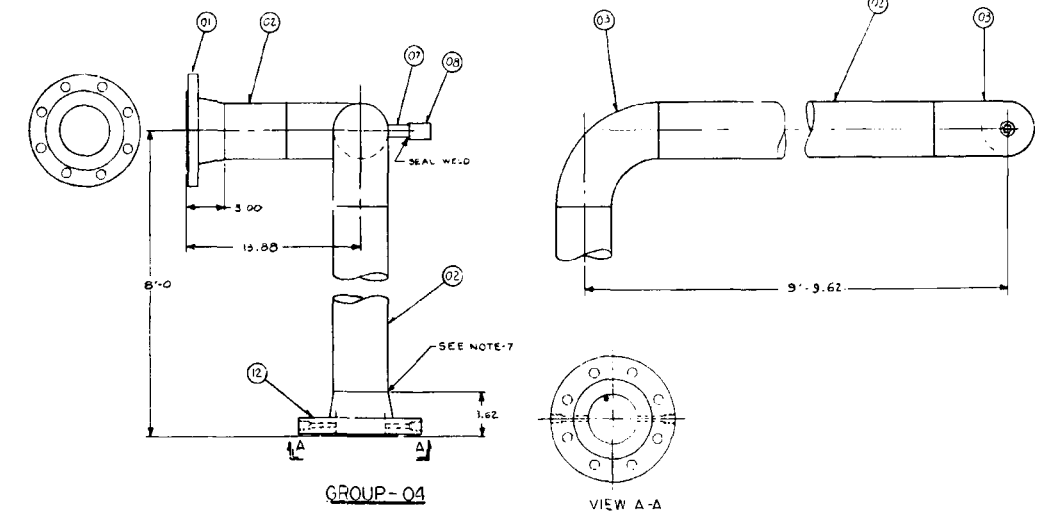
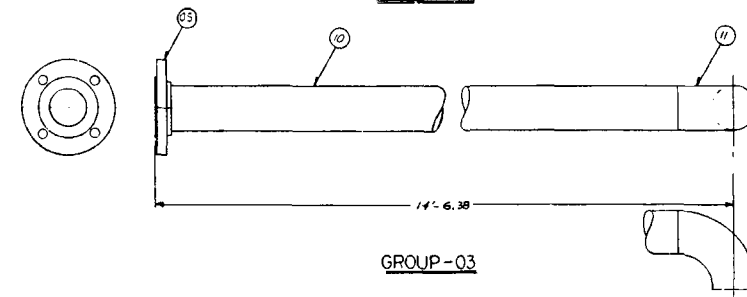
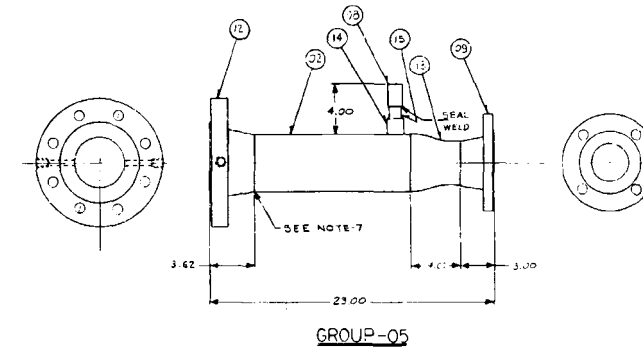
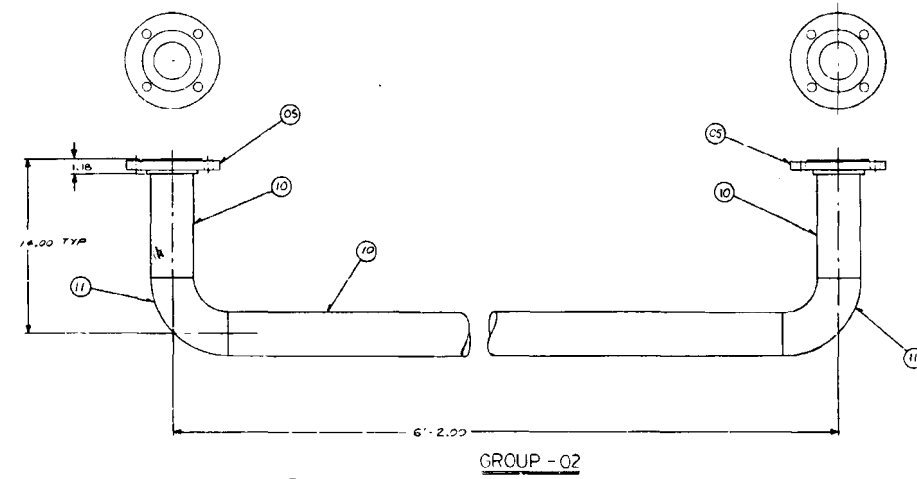
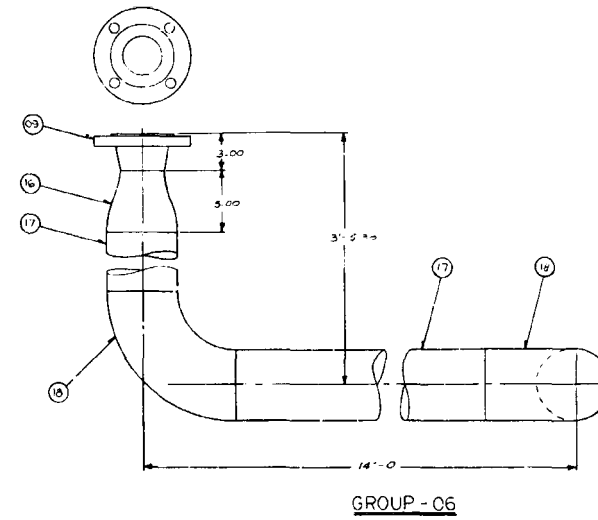
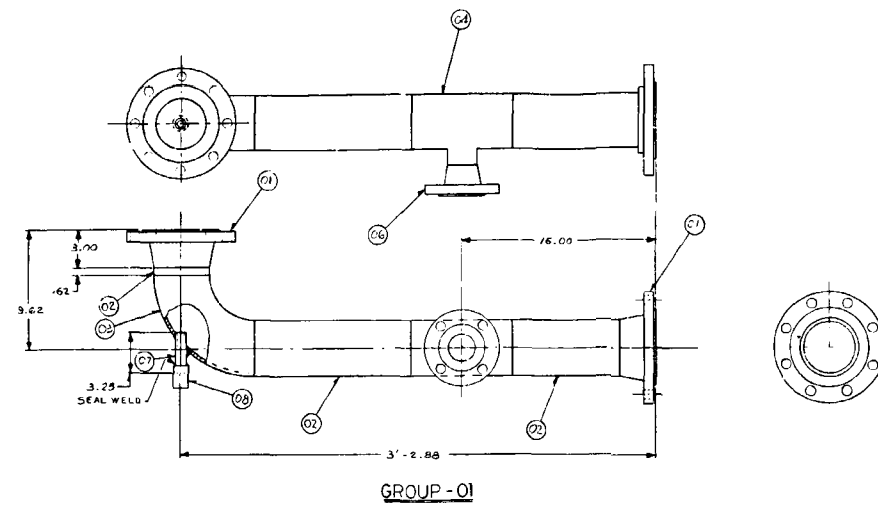

BILL OF MATERIAL									
ITEM #	QTY	PART NAME	DRAWING # OR OR #	MATERIAL	SEE PER GROUP	1	2	3	4
01	1	4" STD W/ FLANGE	SA 105	1					
02	1	4" STD W/ PIPE	SA 105	1					
03	1	4" 30° L R ELBOW STD WT	SA 105	1					
04	1	4" 90° STD W/ TEE	SA 105	1					
05	1	3" ISOLB S/F FLANGE	SA 105	1					
06	1	2" ISOLB W/ FLANGE	SA 105	1					
07	1	1/2" X STD PIPE 3 1/2 LGTH	SA 105	1					
08	1	1/2" W/ 30° L R ELBOW STD WT	SA 105	1					
09	1	3" ISOLB W/ FLANGE	SA 105	1					
10	1	3" STD W/ PIPE	SA 105	1					
11	1	3" 30° L R ELBOW STD WT	SA 105	1					
12	1	4" 30° L R ELBOW STD WT	SA 105	1					
13	1	4" X 3" CONCENTRIC RED STD WT	SA 105	1					
14	1	1/2" ISOLB S/F W/ HALF COUPLING	SA 105	1					
15	1	1/2" X STD PIPE 3 1/2 LGTH	SA 105	1					
16	1	5" X 3" CONCENTRIC RED STD WT	SA 105	1					
17	1	5" STD W/ PIPE	SA 105	1					
18	1	5" 30° L R ELBOW STD WT	SA 105	1					
19									
20									
21									
22									
23									

- NOTES:**
- 1) DESIGN CONDITIONS ALL GROUPS: 60 PSIG @ 700°F
  - 2) GROUPS 01, 03: DESIGN, FABRICATE, TEST AND STAMP PER ASME BOILER # PRESSURE VESSEL CODE, SECTION I (BOILER EXTERNAL PIPING)
  - 3) GROUPS 02, 05, 06: DESIGN, FABRICATE, TEST PER ASME SECTION BOILER EXTERNAL PIPING
  - 4) GROUP 04 (SUPERHEATER): DESIGN, FABRICATE, TEST AND STAMP PER ASME BOILER # PRESSURE VESSEL CODE, SECTION I, HEATER CAPACITY 16MW.
  - 5) IN ADDITION TO ANY CODE INSPECTION REQUIREMENTS, ALL WELDS ARE TO BE ONE PENETRANT EXAMINED BOTH RTT AND FINISHED WELD.
  - 6) HYDROSTATICALLY TEST GROUPS 01, 02, 04 NOT TO 1.5 TIMES DESIGN PRESSURE, PER APPLICABLE CODE. NO HYDRO REQ ON GROUPS 03 #06.
  - 7) GRIND WELD FLUSH WITH I.D. OF PIPE.

Figure B-7. FLECHT SEASET 161-Rod Blocked Bundle Piping Details



## **APPENDIX C**

### **INSTRUMENTATION PLAN**

The 161-rod bundle instrumentation plan will be provided after the fifth test configuration of the 21-rod bundle task.

C.2

## **APPENDIX D**

# **BLOCKED BUNDLE TEST RUN SPECIFICATION AND VALIDATION SHEET**

This appendix contains the test run specification and validation sheet which specifies the initial test conditions and the validation requirements for each FLECHT SEASET 17 x 17 blocked bundle test. This table also provides space for comments on run conditions, causes for terminating and invalidating a run, instrumentation failures, preliminary selected thermocouple data, and drained water weights from collection tanks and the test section.

FLECHT SEASET TEST RUN SPECIFICATION AND VALIDATION SHEET  
(BLOCKED BUNDLE TASK 3.2.3)

RUN NO. \_\_\_\_\_ FACILITY ENGINEERING \_\_\_\_\_

DATE \_\_\_\_\_ SAFEGUARDS DEVELOPMENT \_\_\_\_\_

I. HEATER ROD POWER

Parameter	Specified Value	Actual Value Redundant Power
1. Initial peak linear power	_____ kw/ft ± _____	_____ kw/ft
2. Initial _____ zone power	_____ kw ± 1%	_____ kw
3. Initial _____ zone power	_____ kw ± 1%	_____ kw
4. Initial _____ zone power	_____ kw ± 1%	_____ kw

Note: The power decay should also be ± 1% of specified.

II. INJECTION FLOW

	Specified		Actual	
1. Injection rate				
	Rate	Duration	Rate	Duration
Step 1	_____ gpm	_____ sec	_____ gpm	_____ sec
Step 2	_____ gpm	_____ sec	_____ gpm	_____ sec
2. Coolant supply temperature		_____ °F ± 5°F		_____ °F
3. Initial temperature of coolant injection line		_____ °F ± 10°F		_____ °F

4. Initial temperature of coolant  
in lower plenum

\_\_\_\_\_ °F ± 10°F          \_\_\_\_\_ °F

III. INITIAL TEST SECTION PRESSURE

\_\_\_\_\_ psia ± 5%          \_\_\_\_\_ psia

Note: The test section pressure should not vary by more than 1 psia during the test run, except for the first 20 seconds after flood.

IV. HOUSING TEMPERATURES AT FLOOD<sup>(1)</sup>

1. 2 ft elevation          \_\_\_\_\_ °F

2. 4 ft elevation          \_\_\_\_\_ °F

3. 5 ft elevation          \_\_\_\_\_ °F

4. 6 ft elevation          \_\_\_\_\_ °F

5. 7 ft elevation          \_\_\_\_\_ °F

6. 8 ft elevation          \_\_\_\_\_ °F

7. 10 ft elevation          \_\_\_\_\_ °F

V. LOOP PIPING AND COMPONENT TEMPERATURES

1. Lower plenum          \_\_\_\_\_ °F ± 10°F          \_\_\_\_\_ °F

2. Upper plenum          \_\_\_\_\_ °F ± 20°F          \_\_\_\_\_ °F

---

1. Location E, figure 7-10.

- |                                       |                 |          |
|---------------------------------------|-----------------|----------|
| 3. Carryover tank                     | _____ °F ± 20°F | _____ °F |
| 4. Steam separator                    | _____ °F ± 20°F | _____ °F |
| 5. Steam separator<br>collection tank | _____ °F ± 20°F | _____ °F |
| 6. Exhaust pipe                       |                 |          |
| a) Upstream of separator              | _____ °F ± 20°F | _____ °F |
| b) Downstream of<br>separator         | _____ °F ± 20°F | _____ °F |

Note: Temperature should be an average of all working thermocouples, but each thermocouple should be within limits.

## VI. DACPF INITIALIZATION

- |                                   |           |
|-----------------------------------|-----------|
| 1. Maximum acceptable temperature | _____ °F  |
| 2. Maximum test time              | _____ sec |
| 3. Slow scan time                 | _____ sec |
| 4. Flood temperature              | _____ °F  |
| 5. Power decay delay              | _____ sec |
| 6. Delta T time                   | _____ sec |
| 7. Termination temperature        | _____ °F  |
| 8. Defective temperature          | _____ °F  |

VII. DRPF INITIALIZATION

1. Maximum power \_\_\_\_\_ kw/ft

2. Sink temperature \_\_\_\_\_ °F

VIII. MOTION/STILL PICTURE CONDITIONS

LOCATION

1. 3 ft elevation housing \_\_\_\_\_ frames/sec

2. 6 ft elevation housing \_\_\_\_\_ frames/sec

3. 9 ft elevation housing \_\_\_\_\_ frames/sec

IX. SPECIAL COMMENTS ON RUN CONDITIONS

X. CONDITIONS CAUSING RUN TERMINATION

XI. CONDITIONS CAUSING RUN TO BE INVALID

XII. INSTRUMENTATION FAILURES

XIII. GENERAL COMMENTS ON TEST RUN

#### XIV. PRELIMINARY RESULTS

##### 1. Hottest thermocouple channel at turnaround

Thermocouple Elevation	Initial Temperature at Flood	Maximum Temperature	Flood Time	Turnaround Time	Quench Time
___ ft	___ °F	___ °F	___ sec	___ sec	___ sec

##### 2. Drained water weights

Carryover tank	___ lbm	at ___ °F
Steam separator and collection tank	___ lbm	at ___ °F
Steam probe tank 1	___ lbm	at ___ °F
Steam probe tank 2	___ lbm	at ___ °F
Steam probe tank 3	___ lbm	at ___ °F
Steam probe tank 4	___ lbm	at ___ °F
Steam probe tank 5	___ lbm	at ___ °F
Steam probe tank 6	___ lbm	at ___ °F
Steam probe tank 7	___ lbm	at ___ °F
Test section	___ lbm	at ___ °F

XV. HEATER ELEMENT INSULATION RESISTANCE CHECK

Heater No.	Prior to Test	Posttest
------------	---------------	----------

# APPENDIX E

## DATA REDUCTION AND ANALYSIS COMPUTER PROGRAMS

### E-1. GENERAL

This appendix contains details of the various computer programs which will be used to reduce and analyze the test data from this task. The flow logic diagram for the data reduction methods, shown in figures 9-1 and 9-2, is repeated here as figures E-1 and E-2. Each code is discussed in detail below.

### E-2. F VALID PROGRAM

The program F VALID provides a printout for the test run specification and validation sheet (appendix D). The validation sheet is a specific listing of the data recorded by the PDP 11/20 computer during a test, 1 second before flooding. The listing of these data is used to compare specified values and actual values for the following quantities:

- Heater rod power
- Injection flow
- Initial test section pressure
- Flow housing temperature
- Looping piping and component temperatures

This information is used to determine run validity.

### E-3. FLOOK PROGRAM

The FLOOK program permits the examination of selected analog/digital data from a FLECHT run. Data are taken directly from the disk file on the PDP 11/20 and printed in engineering units. Ten channels may be examined in one pass.

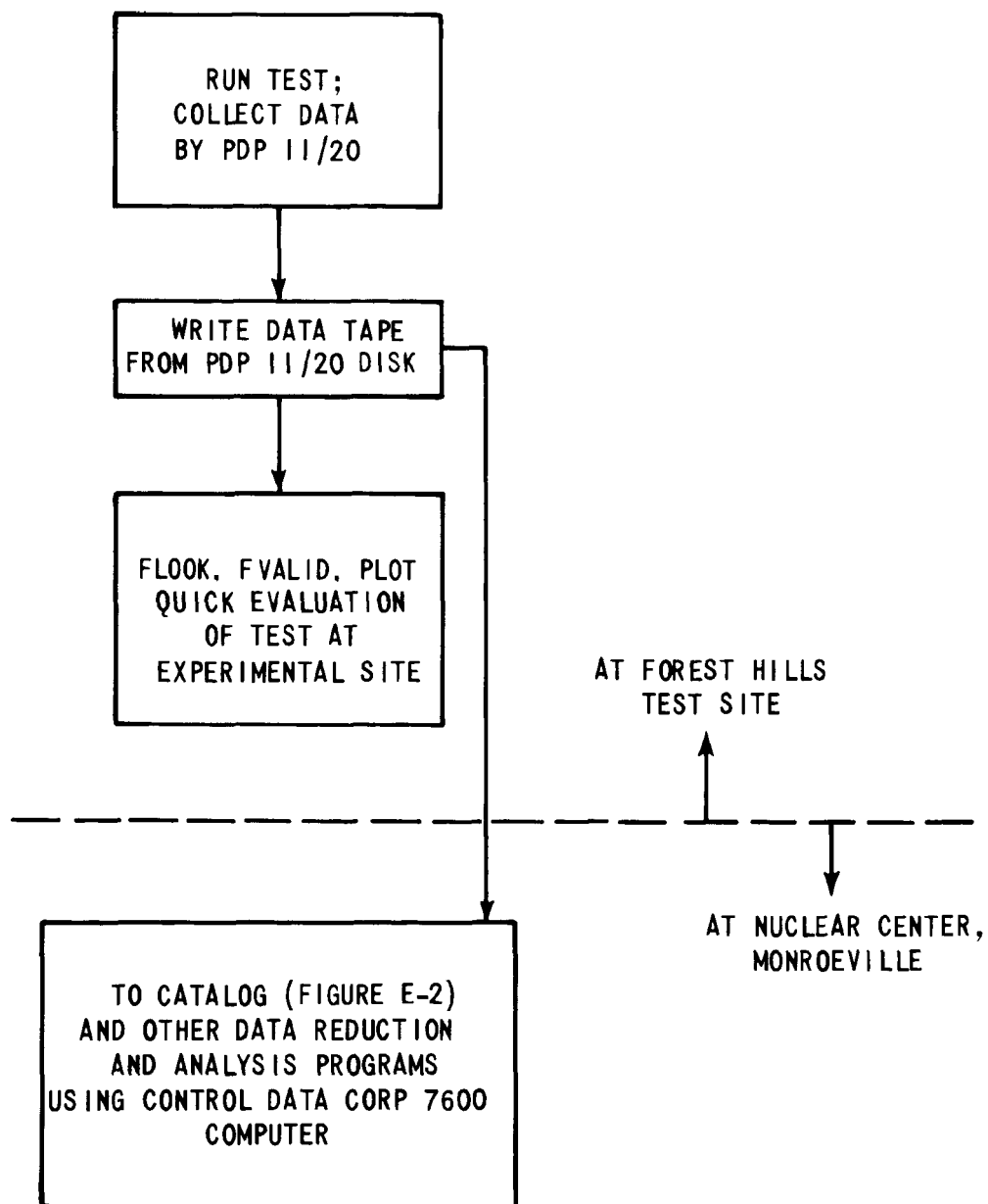

Figure E-1. Flow Logic of Computer Codes

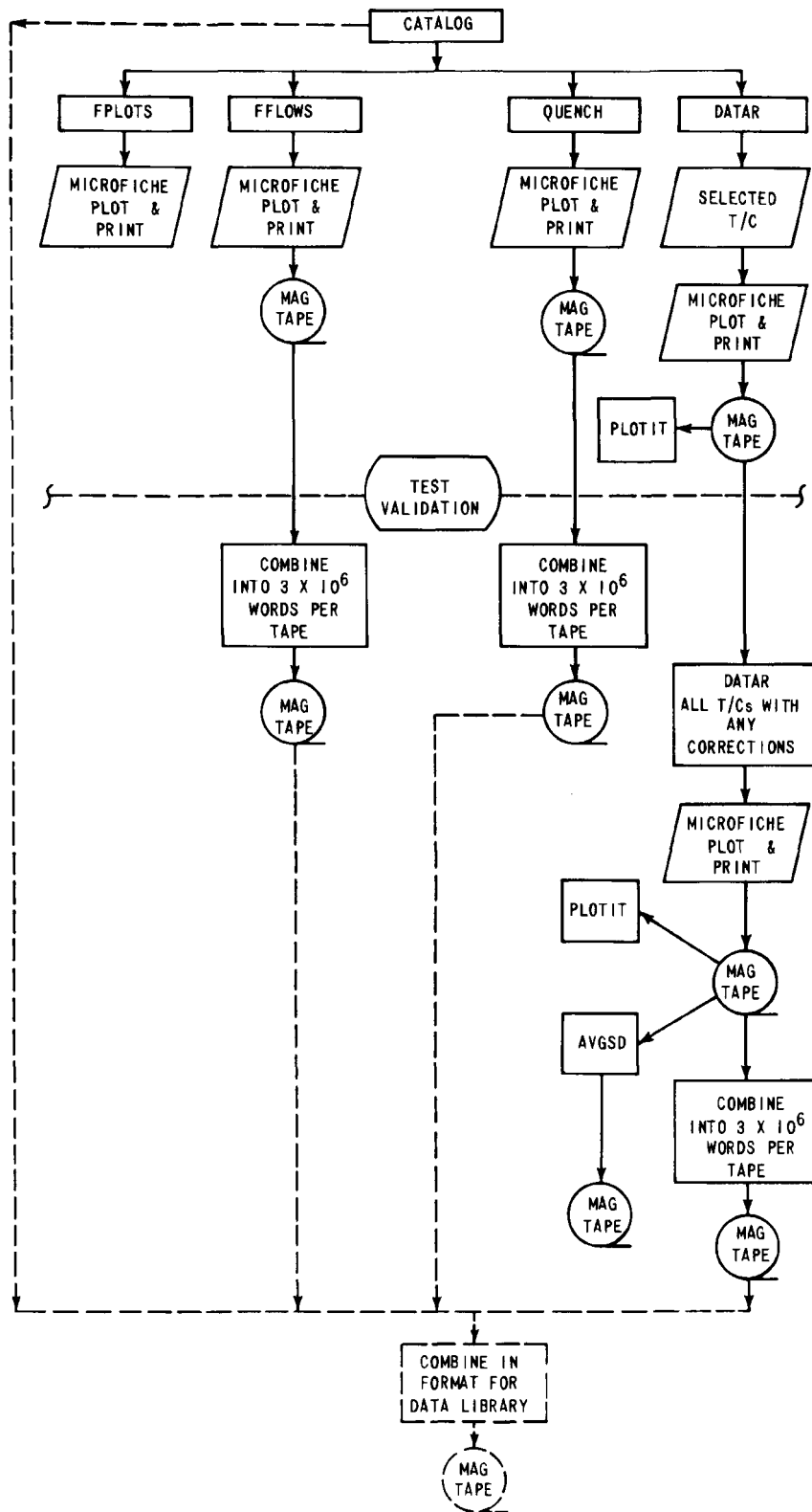

Figure E-2. FLECHT SEASET Data Reduction Flow Chart

#### E-4. PLOT PROGRAM

PLOT is a program which manipulates data that have been stored on the disk such that the necessary conversion, scaling, and formatting of data for the PLOT-10 package is accomplished. PLOT information is entered through the Tektronix 4010, which specifies the graphic functions to be performed. A dialog exists between the operator and computer in a question/answer format. Once the dialog has been completed, a "Y" response to the "Run" command will cause plotting of the desired data. This information is also used in the data validation procedure.

#### E-5. CATALOG PROGRAM

CATALOG is the common name for two programs linked in series: FASTDRP and MAKEBIN. The purpose of CATALOG is to reduce data recorded at the test site to a form that is compatible with the Control Data Corporation (CDC) 7600 system at the Westinghouse Nuclear Center.

FASTDRP takes input from the PDP-11/20 system and converts it to the 60-bit-per-word CDC system. These data are then stored in updated form.

MAKEBIN, using the updated tape, corrects the appropriate channels for instrument shift. The data are then written in a compact form enabling 10 runs to be stored on each tape. (That is, each 60-bit word is converted into 30-bit words, and then two 30-bit words are stored per 60-bit word.)

The output is as follows:

- Raw data in updated form
- Calibration file
- Time array (1 sec -- 0.5 sec -- 1 sec)
- Bad channel list
- Data from each of 556 channels

## E-6. FPLOTT PROGRAM

FPLOTT is a code that presents FLECHT data in tabular and graphic form, using engineering units.

FPLOTT has several options for graphical output, as follows:

- Plot any or all data with a predetermined scale or one that is supplied as test conditions warrant
- Plot any portion of a transient
- Multiplot up to four curves

Input to this code consists of data from all channels connected to the computer for a given test.

## E-7. QUENCH PROGRAM

The QUENCH program determines key quantities associated with heatup and quenching of the heater rod bundle in the FLECHT facility. The quantities determined from QUENCH are heatup rates, initial temperature, turnaround temperature, turnaround time, quench time, and quench temperature. Statistical computations are performed for each quantity to determine maximum, minimum, mean, and standard deviation.

Standard criteria are used to determine rod quench time and temperature. These criteria reduce the possibility of error and the injection of an individual's judgment into the computations. The criteria for heater rod quench are as follows:

- A slope greater than  $10^{\circ}\text{C}/\text{sec}$  ( $50^{\circ}/\text{sec}$ ) and a temperature greater than  $149^{\circ}\text{C}$  ( $300^{\circ}\text{F}$ ). A larger value of slope tends to call any thermocouple noise a quench and a smaller slope tends to miss the quench altogether.
- If the first criterion is not satisfied, the first time the thermocouple reaches saturation temperature.

The PDP 11/20 computer records data from the initiation of heatup sequence, during which the bundle is pulsed, on through reflood. The time scale is shifted such that time = 0 sec corresponds to the beginning of reflood. The heatup period prior to reflood is then rescaled with negative times. The QUENCH program linearly interpolates temperature data to determine the rod initial temperature at time = 0.

In most cases rods do not start to heat up at the same time the computer starts to scan channels. In these cases a time and temperature at the beginning of heatup is calculated. It is assumed that heatup begins when the first 1.1°C (2°F) difference is seen between any two consecutive scans of thermocouples. Heatup rates are found by calculating an average time and temperature over a given time increment. This heatup rate in degrees per second can be used to determine if the correct power is being supplied to the bundle through an energy balance calculation. A more detailed explanation of the QUENCH criteria and assumptions is contained in WCAP-8651<sup>(1)</sup> and WCAP-9108.<sup>(2)</sup> For each valid thermocouple measurement, the output from QUENCH is as follows:

- Heatup rates
- Initial temperature
- Turnaround temperature
- Turnaround time
- Quench time
- Quench temperature

- 
1. Rosal, E. R., et al., "FLECHT Low Flooding Rate Cosine Test Series Data Report," WCAP-8651, December 1975.
  2. Rosal, E. R., et al., "FLECHT Low Flooding Rate Skewed Test Series Data Report," WCAP-9108, May 1977.

## E-8. FFLOWS PROGRAM

The program FFLOWS calculates mass flow rate and mass storage for the FLECHT test section and accompanying loop components. A calculation of the fraction of inlet mass leaving the bundle is performed based on two criteria: (1) mass stored in the test section and (2) mass leaving the test section. An overall system mass balance is performed to account for system losses.

This mass balance takes into account the total mass stored in the test section, the total mass leaving the test loop, and the total mass remaining in the loop after the test. The steam probe collection tanks, upper plenum, and steam separator tank account for the mass remaining after the test. This sum is compared with the total measured mass (M) injected to obtain a mass balance. That is

$$M = \frac{\Sigma M_{\text{injected}} - \left( \Sigma M_{\text{stored in bundle}} + \Sigma M_{\text{out}} + \Sigma M_{\text{stored in loop}} \right)}{\Sigma M_{\text{injected}}}$$

The total mass injected is taken from the inlet turbine meter data. The collected liquid is calculated from the liquid collection tank differential pressure cells assuming saturated liquid conditions. The steam flow is calculated from the orifice meter differential cell using the measured steam temperature and local pressure to obtain a steam density. Mass stored in the test section is calculated from the 0-3.66 m (0-12 ft) differential pressure cell after a correction has been made for frictional pressure drop.

Calculations are also performed to find the average void fraction using the measured pressure drop over each 0.30 m (12 in.) section of the bundle. The measured pressure drop consists of three effects: elevation head, frictional pressure drop, and acceleration drop due to vapor generation. That is,

$$\Delta P_{\text{measured}} = \Delta P_{\text{elevation}} + \Delta P_{\text{acceleration}} + \Delta P_{\text{friction}}$$

WCAP-8238<sup>(1)</sup> and WCAP-9108<sup>(2)</sup> contain detailed descriptions of the frictional pressure drop, measured pressure drop, and void fraction calculations.

Output from FFLOWS is presented in both tabular and graphical form. The following is a list of output quantities from FFLOWS:

- Two-phase pressure drop
- Void fraction
- Two-phase density
- Two-phase mass storage
- Two-phase frictional pressure drop
- Overall pressure drop 0-3.66 m (0-12 ft)
- Overall mass storage 0-3.66 m (0-12 ft)
- Mass difference
- Mass in upper plenum
- Accumulator mass loss
- Mass injected into bundle (total and rate)
- Mass stored in bundle (total and rate)

- 
1. Blaisdell, J. A., et al., "PWR FLECHT SET Phase A Report," WCAP-8238, December 1973.
  2. Rosal, E. R., et al., "FLECHT Low Flooding Rate Skewed Test Series Data Report," WCAP-9108, May 1977.

- Mass out of bundle (total and rate)
- Mass difference (total and rate)
- Carryout fraction (total and rate)
- Test section mass (total and rate)
- Carryover tank mass (total and rate)<sup>(1)</sup>
- Steam separator mass (total and rate)
- Exhaust orifice mass (total and rate)
- Overall mass balance
- Lower bound quality
- Upper bound quality

#### E-9. DATAR PROGRAM

The purpose of the DATAR program is to calculate the heat transfer coefficient and wall heat flux for heater rods in the FLECHT SEASET facility from temperature data (as read from the CATALOG tape), as-built heater rod dimensions, and an inverse conduction mathematical model. The DATAR code consists of 13 overlays, to reduce the computer field length required for code execution. These overlays consist of the following:

- The main program overlay, together with those subroutines necessary to calculate film coefficients

---

1. Based on both mass stored and mass out

- The overlay which controls the reading and checking of input data, both from cards and from tape
- The overlay which checks for restart, properly positions input and output files, if present, and sets internal values
- The overlay which reads input information from the main data tape header and calculates several internal values based on this information
- The overlay which checks card input consistency and echoes the information to printed output
- The overlay which echoes data tape leader information to printed output
- The overlay which reads input from cards and performs miscellaneous operations on the data

The program provides its own dynamic field length management, resulting in minimum operating expense.

With the exception of plotting, the main program controls the flow of all input and output data read and generated by the program. A typical DATAR program is conducted using the following steps:

- (1) Calculate heater rod material radial node positions based on as-built radii and power step interval information. Note that the code performs one-dimensional calculations in the radial direction only. Axial conduction is ignored.
- (2) Calculate appropriate time values for each data point produced. The calibration file values are read by means of a call to the second overlay.
- (3) Enter heater information on the output tape (run number, number of data scans, and the like). Read data tapes and position correctly. Calculate bundle power. The sink temperature is assumed to be the saturation temperature corresponding to the specified pressure for the test.

- (4) Read temperature data for a rod thermocouple from the main data tape and miscellaneous information for that thermocouple (such as bundle position and axial and radial power factors) from a secondary data tape.
- (5) Determine if a thermocouple is good. This is true if its channel number is not included in the bad channel list and the first temperature is greater than  $65.6^{\circ}\text{C}$  ( $150^{\circ}\text{F}$ ). If these two criteria are not met, a short entry is made on the output tape and data from the next channel are read.
- (6) Calculate rod temperature profiles, surface heat flux, and heat transfer coefficients by successively calling data reduction subroutines in the model. The number of future temperatures used is determined by the shape of the temperature-versus-time curve at the next time. This number is constrained to be between 1 and 3, and may be different from the previous value by no more than 1.
- (7) Enter data results of calculations performed in step (6) on output. Plot clad temperature and heat transfer coefficient using a call to the third overlay.
- (8) Repeat steps (4) through (7) for all bundle thermocouple channels and terminate data reduction.

DATAR uses four principal subroutines. The function of each of these is as follows:

- (1) To calculate the coefficient matrix (solution-to-simultaneous equation set)
- (2) To calculate the temperatures and surface heat flux given the coefficient matrix
- (3) To invert the tridiagonal coefficient matrix
- (4) To smooth surface heat flux and heat transfer coefficient over a 10-second time window

Several other subroutines perform miscellaneous calculations, such as material property evaluation and data interpolation.

## E-10. AVGSD PROGRAM

AVGSD is a statistical program used to evaluate the large volume of data produced by DATAR. Calculations are performed to obtain a time-dependent mean; one standard deviation, maximum, and minimum for the measured temperature; calculated surface temperature; heat flux; and heat transfer coefficient. This calculation is performed at each elevation for which valid data exist. In addition, at each elevation the data are grouped into power zones. Input to this program consists of the output tape from DATAR.

The quantities below are output from AVGSD in both graphical and tabular form for measured temperature, heat flux, and heat transfer coefficients:

- Time
  
- Group (a given set of heater rod thermocouples at an elevation)
  
- Average
  
- Standard deviation
  
- Maximum
  
- Channel number from which maximum value came
  
- Minimum
  
- Channel number from which minimum value came

## E-11. ALLTURN PROGRAM

ALLTURN computes heat transfer coefficients based on distance above the quench front. This is accomplished in two ways: (1) using reduced experimental data output from the QUENCH and DATAR programs and (2) using a FLECHT-type empirical correlation based on run conditions.

When DATAR results are reduced, thermocouples within an inner rod array are used for a uniform radial power distribution. When the power is a FLECHT radial distribution only, the high-power (1.1 power factor) rods within the same array are used to eliminate any effects caused by the housing. At each time of interest, a quench elevation is determined from the QUENCH code output. The difference between this elevation and the elevation of interest is the distance above the quench front. Average heat transfer coefficients at each time and elevation are calculated. These experimental results are compared with predicted heat transfer coefficients calculated by a trial correlation. A detailed description of this correlation and comparisons are contained in WCAP-9183.<sup>(1)</sup>

#### E-12. FLEMB PROGRAM

FLEMB performs a mass and energy balance on the FLECHT bundle. Input is taken from DATAR, FFLOWS, and CATALOG output tapes. FLEMB consists of a main program and two principal subroutines. The main program controls the input, the output, and the user-selected method by which local mass flow, local quality, and local enthalpy are calculated. The local mass options are as follows:

- Without mass storage above quench front based on mass stored in the bundle
- Without mass storage above quench front based on mass out of the bundle
- With mass storage above quench front based on mass stored in the bundle
- With mass storage above quench front based on mass out of the bundle

The basic equation for calculating the local mass flow at any differential pressure cell location  $i$  corresponding to 0.305, 0.610, 0.914, . . . 3.66 m (1, 2, 3, . . . 12 ft) is

$$\dot{m}_i = \dot{m}_{i-1} - \frac{d}{dt} (m_{\text{stored } i-1,i})$$

---

1. Lilly, G. P., et al., "PWR FLECHT Skewed Profile Low Flooding Rate Test Series Evaluation Report," WCAP-9183, November 1977.

Local enthalpy options are as follows:

- Without mass and energy storage above quench front
- With mass and energy storage above quench front

The basic equation for calculating local quality is

$$h(z) = xh_v(z) + (1-x)h_f(z)$$

where  $h(z)$  is the local enthalpy [refer to equation (E-1) below].

Local vapor temperatures supplied by the steam probes are used to calculate a local nonequilibrium quality.

A detailed description and examples of code output are contained in WCAP-9183.

The functions of the two subroutines are as follows:

- To integrate heat flux data to find the heat release from the quench front to the 3.66 m (144 in.) elevation. The basic form of the equation is

$$m_{\text{bundle exit}} h_{\text{bundle exit}} - h(z) = \int_z^{\text{bundle exit}} Q' dz \quad (\text{E-1})$$

where  $Q'$  = bundle heat release rate per foot

- To extract needed data from input and arrange it into the form needed by the program

Calculations within FLEMB are based on the following assumptions:

- Quasi-steady state
- Liquid at saturation temperature

-- Negligible stored energy within a low-mass housing

Output from FLEMB is in tabular and graphical form as follows:

-- Mass flow rate

-- Enthalpy

-- Local quality

-- Equilibrium quality

-- Vapor temperature

-- Rod wall temperature

-- Local Reynolds number

-- Void fraction

-- Hot rod heat flux

-- Radiation heat flux

-- Nusselt number

-- Total integrated heat flow

-- Net heat flow to drops

### E-13. HEAT-II PROGRAM

HEAT-II calculates the heat transfer to the entrained liquid droplets and the steam, using the method of Sun, et al.,<sup>(1)</sup> along with a dynamic droplet model<sup>(2)</sup> developed in the FLECHT program.

Input to HEAT-II is generated by the FLEMB program. This input includes mass flow rates, quality, steam temperature, wall temperature, and hot rod heat flux.

When appropriate, a linear interpolation model is used to obtain the desired data. The calculations within HEAT-II are based on the following assumptions:

- Quasi-steady state
- Constant system pressure
- Liquid at saturation conditions
- Positive droplet velocity and acceleration
- Slip (or void fraction) given at quench front

A typical run contains the following steps:

- (1) Calculate initial drop size.
- (2) Calculate slip and droplet volumetric density.

- 
1. Sun, K. H., et al., "Calculations of Combined Radiation and Convection Heat Transfer in Rod Bundles Under Emergency Cooling Conditions," Trans. Amer. Soc. Mech. Engrs. 98, Series C, 414-416 (1976).
  2. Lilly, G. P., et al., "PWR FLECHT Skewed Profile Low Flooding Rate Test Series Evaluation Report," WCAP-9183, November 1977.

(3) Determine the effect of initial void on slip.

(4) Calculate the radiation to vapor and drops using the method of Sun, et al.

Output from HEAT-II contains the following quantities:

- Droplet diameter
- Droplet number density
- Droplet velocity
- Droplet Reynolds number
- Droplet Weber number
- Vapor velocity
- Slip ratio
- Void fraction
- Rod heat flux
- Wall-to-vapor radiation heat flux
- Wall-to-droplet radiation heat flux
- Surface-to-surface radiation heat flux
- Wall-to-vapor convection heat flux
- Heater rod wall-to-vapor heat transfer coefficient
- Vapor Nusselt number

- Quality
- Heater rod wall temperature
- Steam temperature

NRC/EPRI/WESTINGHOUSE REPORT NO. 6  
EXTERNAL DISTRIBUTION

Dr. L. S. Tong, Assistant Director  
Water Reactor Safety Research  
Division of Reactor Safety Research  
U.S. Nuclear Regulatory Commission  
Washington, DC 20555

Dr. H. Sullivan  
Division of Reactor Safety Research  
U. S. Nuclear Regulatory Commission  
Washington, DC 20555

A. L. M. Hon  
Separate Effects Research Branch  
U. S. Nuclear Regulatory Commission  
Washington, DC 20555

K. V. Morton, Chief  
Research Contracts Branch  
Division of Contracts  
U. S. Nuclear Regulatory Commission  
Washington, DC 20555

D. E. Solberg  
U. S. Nuclear Regulatory Commission  
Washington, DC 20555

Mr. Wayne Hodges  
U. S. Nuclear Regulatory Commission  
DSS  
Washington, DC 20555

Mr. L. Phillips  
NRR  
U. S. Nuclear Regulatory Commission  
Washington, DC 20555

Mr. Harry Balukjan  
NRR  
U. S. Nuclear Regulatory Commission  
Washington, DC 20555

Dr. D. Ross  
NRR  
U. S. Nuclear Regulatory Commission  
Washington, DC 20555

Dr. W. Johnston  
Core Performance Branch  
U. S. Nuclear Regulatory Commission  
Washington, DC 20555

Dr. B. Bingham  
Babcock & Wilcox Company  
P. O. Box 1206  
Lynchburg, VA 24505

Mr. N. H. Shah  
Babcock & Wilcox Co. (NPGD)  
P.O. Box 1260  
Lynchburg, VA 24505

Mr. W. Kayser  
Exxon Nuclear  
2101 Horn Rapids Road  
Richland, WA 99352

Mr. G. E. Wilson (TSB)  
EG&G Idaho, Inc.  
P. O. Box 1625  
Idaho Falls, ID 83401

J. A. Dearien  
EG&G Idaho, Inc.  
P. O. Box 1625  
Idaho Falls, ID 83401

P. North  
EG&G Idaho, Inc.  
P. O. Box 1625  
Idaho Falls, ID 83401

Mr. G. Sozzi  
General Electric Co.  
175 Curtner Avenue  
San Jose, CA 95125

Dr. P. Griffith  
Dept. of Mechanical Engineering  
MIT  
Cambridge, MA 02139

Dr. P. A. Lottes  
Argonne National Laboratory  
9700 South Cass Avenue  
Argonne, IL 60439

Mr. G. Ofey  
Sandia National Laboratory  
P.O. Box 5800  
Albuquerque, NM 87185

Dr. F. Mynatt  
Engineering Technology Division  
Oak Ridge National Laboratory  
Box 7  
Oak Ridge, TN 37830

Mr. R. Jensen  
Intermountain Technology  
Box 1604  
Idaho Falls, ID 83401

Mr. F. D. Lang  
Energy Incorporated  
P. O. Box 763  
Idaho Falls, ID 83401

Dr. J. Chen  
Lehigh University  
Dept. of Mechanical Engineering  
Bethlehem, PA 18015

Dr. K. H. Sun (5 copies)  
Nuclear Power Division  
Electric Power Research Institute  
P. O. Box 10412  
Palo Alto, CA 94303

Dr. J. J. Cudlin  
Power Generation Group  
Babcock & Wilcox  
P. O. Box 1260  
Lynchburg, VA 24505

Mr. J. Longo, Jr.  
Combustion Engineering  
P. O. Box 500  
Windsor, CT 06095

Mr. J. Blaisdell  
Combustion Engineering  
P.O. Box 500  
Windsor, CT 06095

Mr. Ken Moore  
Energy, Inc.  
P. O. Box 736  
Idaho Falls, ID 83401

Dr. K. P. Galbraith  
Nuclear Safety Engineering  
Exxon Nuclear Company  
2101 Horn Rapids Road  
Richland, WA 99352

Dr. J. A. Block  
Create Inc.  
Hanover, NH 03755

Dr. W. Hancox  
Whiteshell Nuclear Laboratory  
Atomic Energy of Canada  
Pinawa, Manitoba  
Canada ROE 1LO

Professor T. Theofanous  
Department of Nuclear Energy  
Purdue University  
West Lafayette, IN 47907

Professor I. Catton  
Dept. of Chemical, Nuclear, and  
Thermal Engineering  
University of California  
Los Angeles, CA 90024

Dr. Max W. Carbon  
Nuclear Engineering Department  
The University of Wisconsin  
Madison, WI 53706

Professor R. A. Seban  
Dept. of Mechanical Engineering  
University of California  
Berkeley, CA 94720

Professor W. Y. Chon  
Dept. of Engineering Science,  
Aerospace Engineering, and  
Nuclear Engineering  
State University of New York  
Buffalo, NY 14214

Dr. R. R. Gay  
Nuclear Engineering Department  
Rensselaer Polytechnic Institute  
Troy, NY 12181

Dr. Owen Jones  
Brookhaven National Laboratory  
Building 820  
Upton, NY 11973

Professor E. V. McAssey, Jr.  
Dept. of Mechanical Engineering  
Villanova University  
Villanova, PA 19085

Professor S. C. Yao  
Dept. of Mechanical Engineering  
Carnegie-Mellon University  
Pittsburgh, PA 15213

Dr. S. J. Board  
CEGB  
Berkeley Nuclear Laboratory  
Berkeley  
Gloucestershire, England

Prof. T. Wu  
California Institute of Technology  
Pasadena, CA 91109

Dr. S. Levy  
S. Levy, Inc.  
1901 S. Bascom Ave. Suite 275  
Campbell, CA 95008

Dr. D. A. Prelewicz  
NUS Corporation  
4 Research Place  
Rockville, MD 20850

Professor A. Tapucu  
Ecole Polytechnique,  
Universite de Montreal  
Institut de Genie Nucleaire  
Casier Postale 6079  
Succursale "A,"  
Montreal, Quebec H3C 3A7

for NRC (360 copies)  
Distribution Services Branch  
Nuclear Regulatory Commission  
7920 Norfolk Avenue  
Bethesda, MD 20555

Ms. Nora Schofield  
EG&G Idaho, Inc.  
P. O. Box 1625  
Idaho Falls, ID 83401