

GA-A20112

# INFRARED THERMOGRAPHY SYSTEM ON DIII-D

GA-A--20112

DE91 001294

by

T.W. Petrie, D.N. Hill,\*  
J. Baptista,\* and M. Brown\*

\*Lawrence Livermore National Laboratory

This is a preprint of a paper to be presented at the 8th Topical Conference on High Temperature Plasma Diagnostics, May 7-10, 1990, Hyannis, Massachusetts, and to be printed in the *Proceedings*.

Work supported by  
Department of Energy  
Contract DE-AC03-89ER51114

GENERAL ATOMICS PROJECT 3466  
OCTOBER 1990

MASTER



**GENERAL ATOMICS**

MASTER *etc*

DISTRIBUTION OF THIS DOCUMENT IS UNLIMITED

## Infrared thermography system on DIII-D

T.W. PETRIE, D.N. HILL,\* J. BAPTISTA,\* AND M. BROWN\*

*General Atomics, San Diego, California 92186-9084*

*\*Lawrence Livermore National Laboratory.*

Six infrared cameras measure temperature changes on the protective graphite armor inside the DIII-D vacuum vessel. Simultaneous time dependent temperature measurements are made on armor tiles located on the centerpost and divertor regions, and on both outboard limiters. The nearly-complete poloidal coverage is useful in measuring both the plasma heat flux distributions inside the vessel and the plasma power balance. Spatial resolution of each camera system is  $\lesssim 1$  cm, while the minimum resolvable time is  $125 \mu\text{sec}$ . Data from the IR TV systems is recorded on video tape, and is post-processed serially, using an image processor with an AT-compatible microcomputer. The processing system controls all VCRs, interprets DIII-D timing pulses, digitizes video data in the pre-determined regions of interest, averages digitized signals to reduce noise, and constructs data files which are then stored as part of the permanent shot record.

## INTRODUCTION

The DIII-D tokamak is capable of operating with up to 20 MW of long-pulse ( $\approx 5$  sec) auxilliary heating. This type of operation poses both engineering- and physics-related concerns. For example, intense localized heating over an extended period risks thermal damage to the graphite tiles protecting the DIII-D vessel, as well as adversely affecting plasma boundary physics processes<sup>1</sup> (e.g., particle recycling and impurity ion source production).

Data provided by infrared (IR) imaging will play an important role in addressing these issues. Properly calibrated, IR imaging provides the time history of surface temperature on each spatially resolvable element in the field-of-view (FOV). From this temporal history, the heat flux can be deduced. Thus, IR imaging provides both temporal and spatial information on surface temperature and heat flux.

This paper describes the IR imaging system used on DIII-D. Much of the DIII-D vessel is covered by an array of graphite tiles (Union Carbide TS-1792), as shown in Fig. 1. Areas of particular interest for thermal study are Upper Divertor, Lower Divertor and Centerpost. Also of interest are the two toroidally-localized, graphite-tiled limiters that protect the outboard side of the vessel, similar to the one shown in Fig. 1. In Section I we describe the IR imaging optics that are used to monitor these regions. Section II describes how the IR data is acquired, processed, and stored following a plasma "shot". In Section III, we give an example of processed IR camera data.

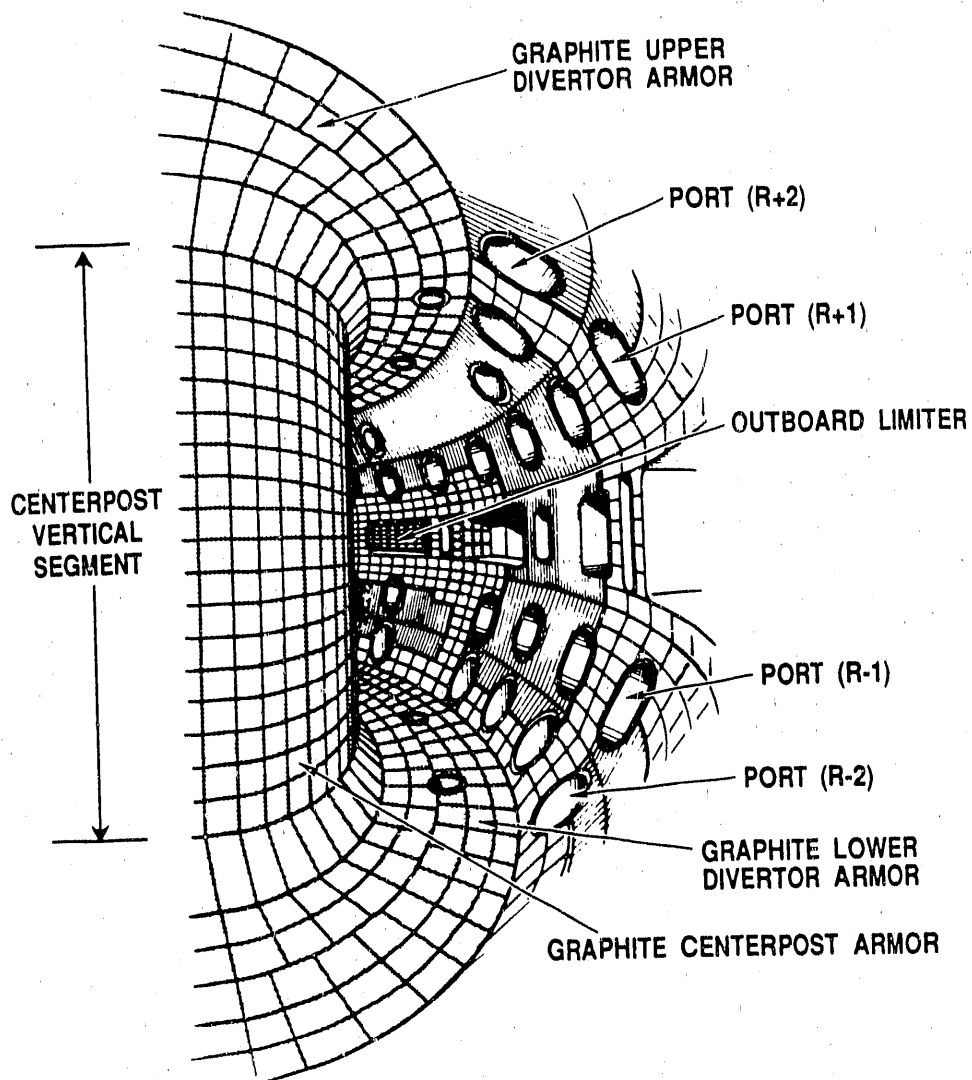

Fig. 1. Interior view of the DIII-D vessel shows that graphite tiles completely cover the centerpost, upper divertor, and lower divertor. One of the two outboard limiters is also shown.

## I. IR CAMERA SYSTEMS

### A. Field-of-view

Figure 2(a) shows a plan view of the FOVs of the six principal IR TV cameras on DIII-D, as viewed from on top of the DIII-D vessel. These cameras monitor the

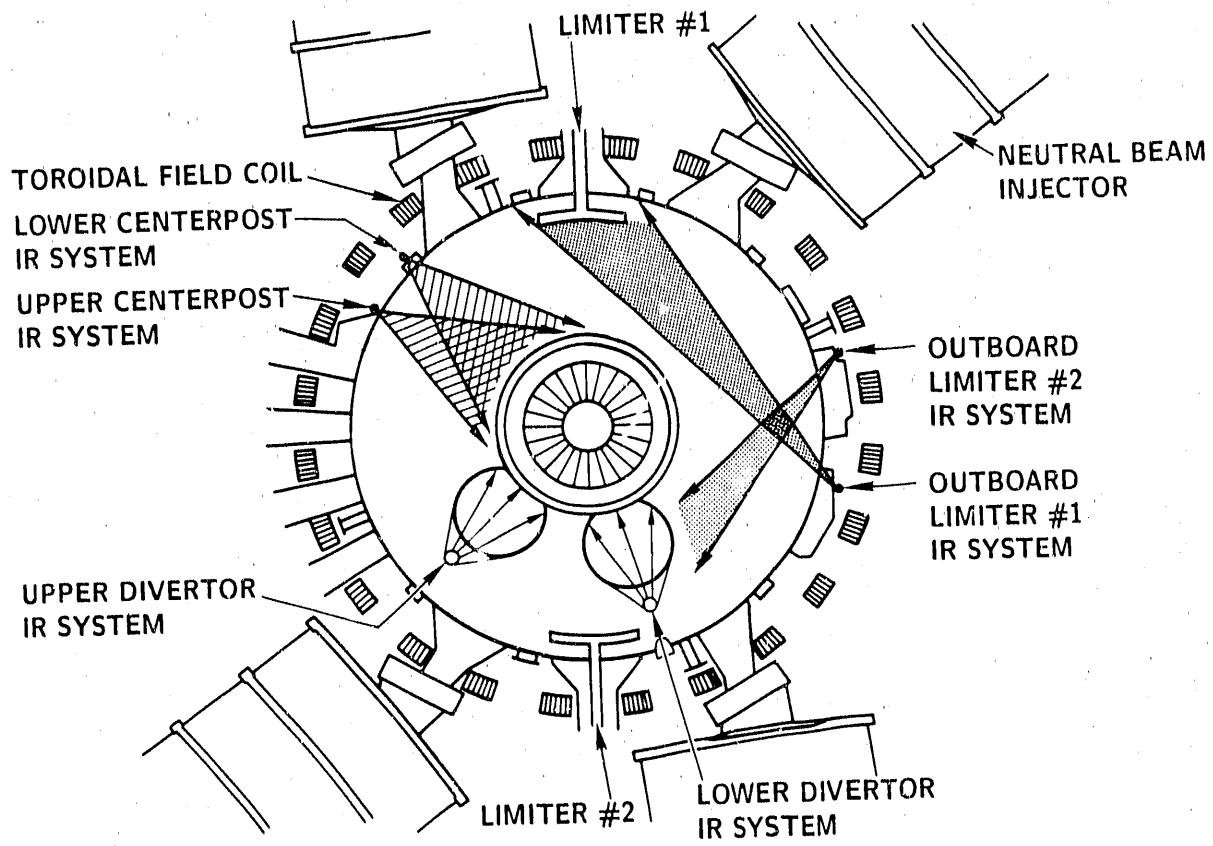

Fig. 2(a). Toroidal locations and field-of-views of the principal IR imaging units on DIII-D are shown. Both divertor and centerpost systems have a limited toroidal FOV.

following three regions of interest: (1) outboard limiters, (2) upper/lower divertors, and (3) centerpost. The two outboard limiters are viewed individually by optically-identical IR systems. The IR imaging units that monitor the upper and lower divertors give a complete radial view of divertor tiles at their respective toroidal locations [Fig. 2(b)], although the FOV in the toroidal direction is localized [Fig. 2(a)]. The divertor IR imaging systems are optically identical. Two camera systems are needed

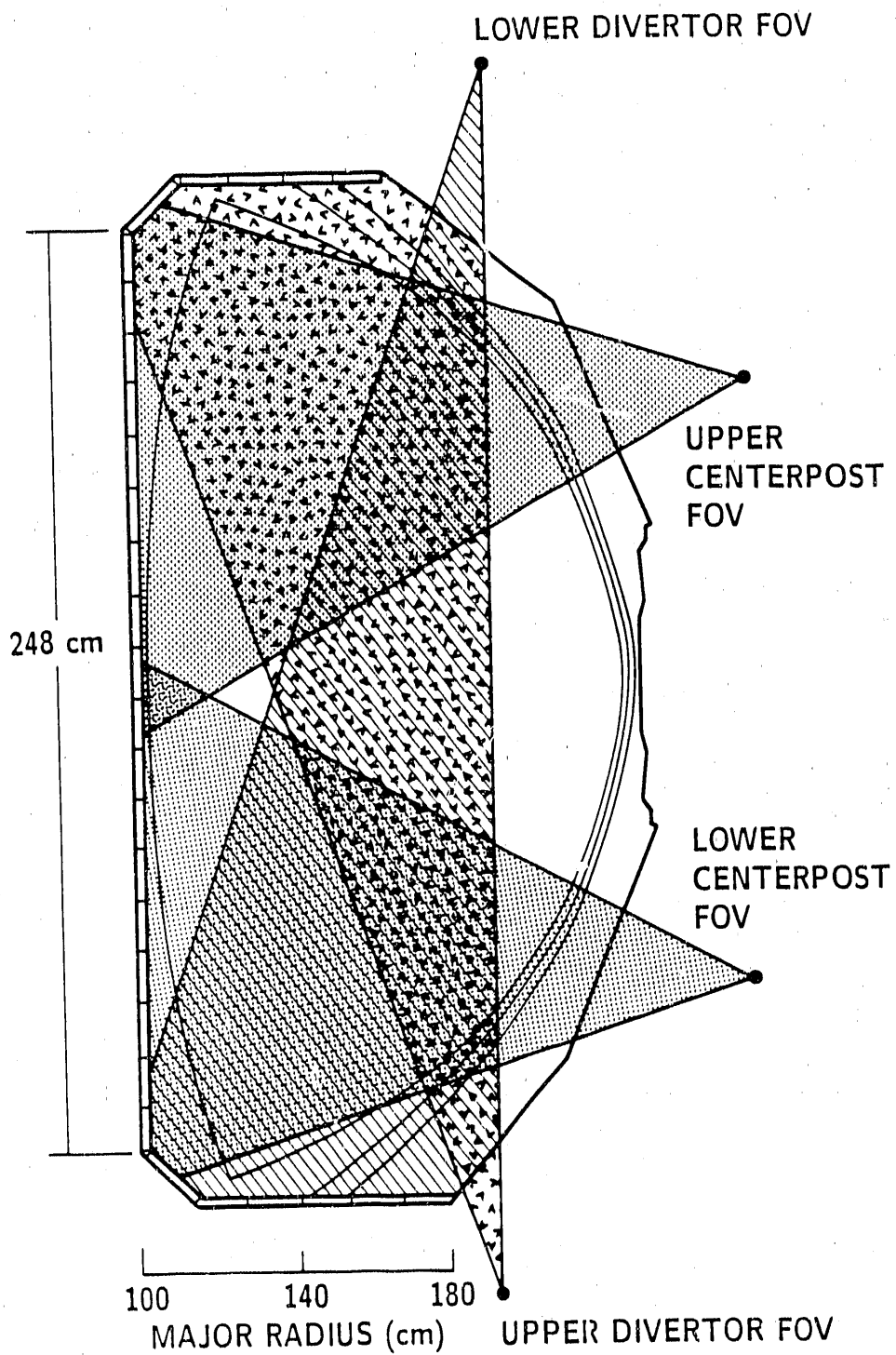

Fig. 2(b). Cross-sectional FOVs of the divertor and centerpost imaging units overlap. The plasma shape is for a double-null divertor.

in monitoring the centerpost [Fig. 2(b)]. Although their toroidal locations are displaced slightly [Fig. 2(a)], the overlap in their FOVs provides complete coverage of the centerpost at an intermediate toroidal location. The two centerpost IR systems are also optically identical to each other.

## B. Optical design

A schematic of the lens and camera elements for each of the above three types of IR camera systems is shown by Fig. 3 and described in more detail in Table 1. The outboard limiter- and the divertor monitoring systems are optically similar, although their maximum FOVs are somewhat different. A single objective lens projects the image onto a single field lens, which in turn relays the light back to the IR camera. Attached to the IR camera is a 3x telescope, which sets the FOV of the camera/telescope to match the field lens ( $\approx 6^\circ$ ). A "close-up" lens mounted immediately in front of the camera/telescope improves the image quality by converting the convergent rays coming in from the field lens into parallel rays.

Because the FOV of the centerpost systems is fairly wide (maximum FOV =  $45^\circ$ ), image distortion (*e.g.*, "barrel") is a serious problem, and the relatively simple optical design used in the above outboard limiter- and divertor systems is inadequate. To minimize image distortion and insure adequate spatial resolution of the centerpost, an optical design was developed by R. Gelles in association with Infrared Optical Products Inc., shown in Fig. 3. The objective is a doublet with an aperture stop (not shown) between the front and rear components. The intermediate focus is placed between the two field lens components. As with the outboard limiter- and divertor

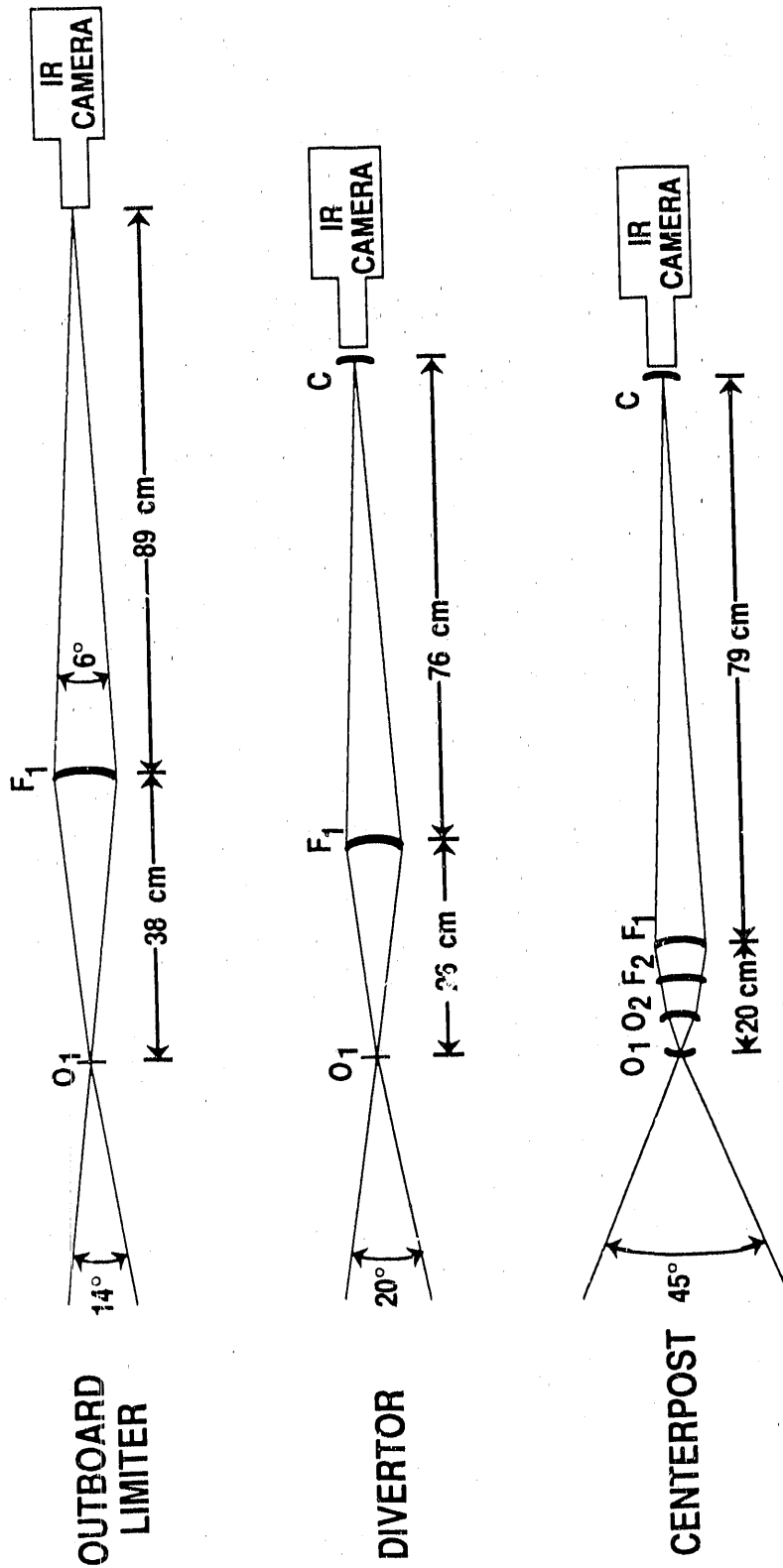

Fig. 3. Schematic of the optical systems used to image the outboard limiters, divertors, and centerpost is shown. We use Inframetrics 525 imaging cameras with 8-bit resolution, which are sensitive to 3-5 micron and 8-12 micron radiation.

# TABLE 1: GENERAL DESCRIPTION OF OPTICS

Target Region	Outboard Limiter	Upper/Lower Divertor	Centerpost
FOV (deg)	14	20	45
Distance of O <sub>1</sub> from target, cm	≈410	≈300	≈160
Spatial resolution at target, cm	1.2	0.5	0.9
Vacuum window:			
Type	Bi-planar	Bi-planar	Bi-planar
Material	Sapphire	ZnSe	ZnSe
Thickness (cm)	0.6	2.5	2.5
AR coating	None	None	None
Lens O <sub>1</sub> :			
f.l. (cm)	35.0	24.0	2.6
Type	Plano-convex	Meniscus	Meniscus
Material	ZnSe	Ge	Ge
AR coating	3-5	3-14	3-14
Lens O <sub>2</sub> :			
f.l. (cm)	-	-	7.6
Type	-	-	Meniscus
Material	-	-	Ge
AR coating	3-5	3-14	3-14
Lens F <sub>2</sub> :			
f.l. (cm)	-	-	23.9
Type	-	-	Plano-convex
Material	-	-	Ge
AR coating	3-5	3-14	3-14
Lens F <sub>1</sub> :			
f.l. (cm)	26.7	19.6	39.7
Type	Plano-convex	Meniscus	Plano-convex
Material	CaF	Ge	Ge
AR coating	3-5	3-14	3-14
Lens C:			
f.l. (cm)	-	76.0	79.0
Type	-	Meniscus	Meniscus
Material	-	Ge	Ge
AR coating	3-5	3-14	3-14

systems, the field lens components then re-image the aperture stop at the front lens of the IR camera telescope. This system preserves image linearity to within 5%.

In each of the three types of IR systems, spatial resolution is ultimately determined by the inherent resolution of the Inframetrics 525 camera we use for these systems. The angular resolution of the outboard limiter-, divertor-, and centerpost IR systems are approximately 2.8-, 1.6-, and 4.7 milliradians, respectively, which translate into a spatial resolution of typically 1.2 cm, 0.5 cm and 0.9 cm, respectively. The time response of these IR systems to changes in surface temperature is  $\sim 125$  microseconds (in the 8 kHz operating mode). The minimum resolvable temperature  $\sim 0.3^\circ\text{C}$ .

## II. DATA PROCESSING

### A. Overview

All available IR camera video data is processed by what we refer to as the Digitizing and Processing System (DPS). The main tasks of the DPS are to automatically record incoming IR video data, digitize and process this data according to predetermined algorithms, and transfer these processed data files to the General Atomics VAX-cluster network for permanent storage.

Figure 4 shows a schematic of data flow through the DPS. During each plasma shot video data from each operating IR camera are recorded on a Panasonic AG 6300 video cassette recorder. Timing information is also encoded onto the tape. (The DPS timing reference is derived from the 1 MHz DIII-D master clock.)

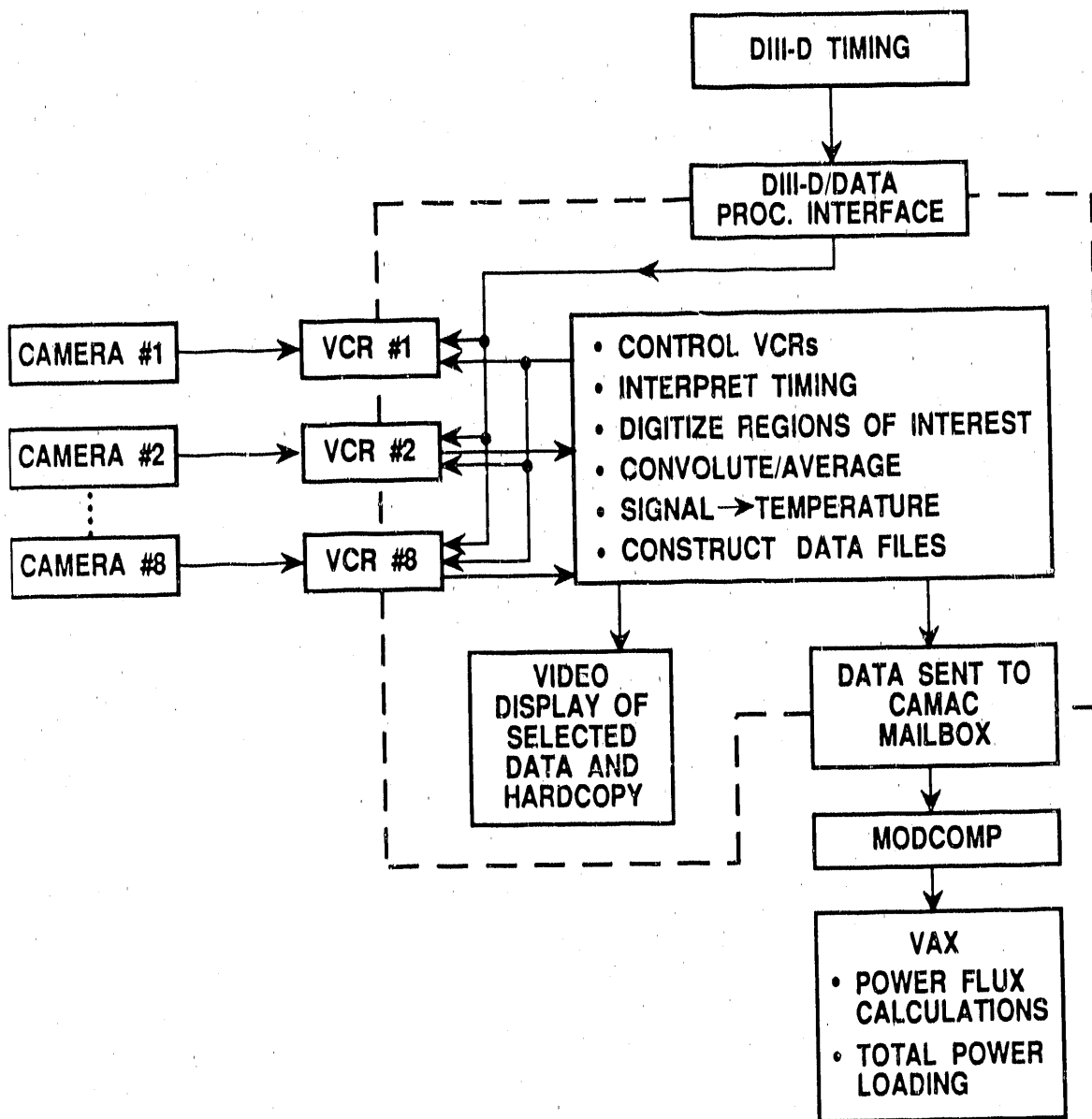

Fig. 4. Schematic of data flow through the DPS (inside dashed lines).

After each shot is over, video data from each of the VCRs is sent sequentially to a TRAPIX 55/64 image processor (*Recognition Concepts Inc.*). The TRAPIX digitizes images in the region of interest, pixel averages to reduce signal noise, and

creates suitable data files. Control and programming of the TRAPIX is done on an AT-compatible microcomputer (*Joy 286*).

After all IR camera video data has been processed and packed in file format, the data is sent to a CAMAC "mailbox" (*Interface Standard DM-16*), where it is temporarily stored. Six minutes after the end of the shot, this data is retrieved by a MODCOMP minicomputer and then sent to permanent storage on the VAX-cluster network, where detailed analyses may be performed.<sup>2</sup>

## B. Crucial interface issues

The most critical issues of the DPS are related to VCR control, such as recording shot time and shot number, selecting a video source for the TRAPIX unit and recording shots without the TRAPIX/AT-compatible computer being operational. Our approach in addressing these issues is shown in Fig. 5. Each camera is connected to a video interval time code (VITC) encoder, which places the DIII-D timing information into the vertical interval of the video signal. The output signal of all VITC encoders (*Gray Engineering Laboratories, VIE-224S*) are connected to their respective VCRs. The output of each recorder is connected to a video switcher (*Grass Valley Group, TEN-XLV*), which is controlled with an RS-232 line from the interface chassis. The output of the switcher is sent to the VITC decoder (*Gray Engineering Laboratories, VCG-228S*), which decodes and displays timing information. One of the two video outputs from the decoder goes to a local monitor, while the other goes to the TRAPIX.

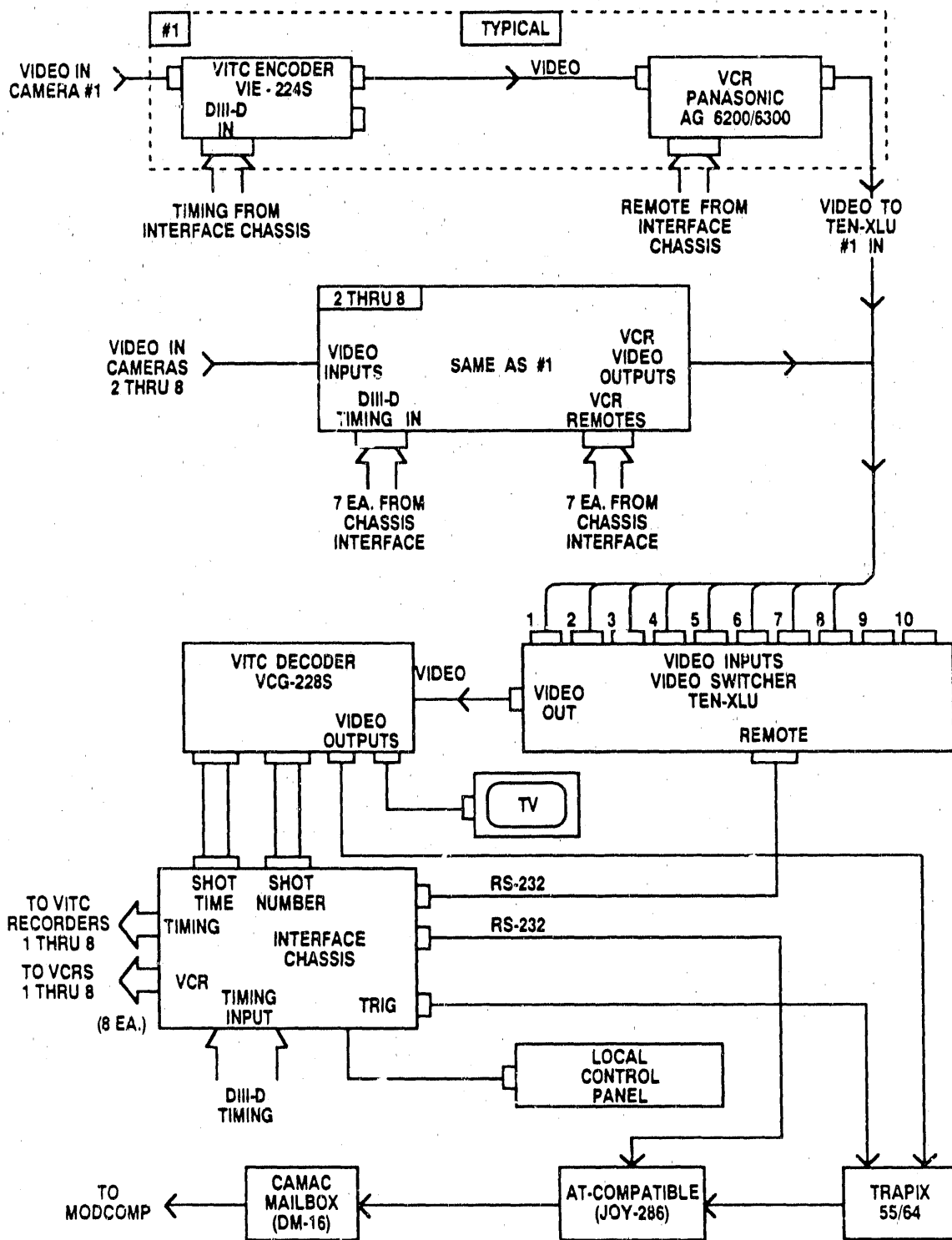

Fig. 5. Detailed schematic of the TRAPIX/AT interface with the externally generated DIII-D timing triggers and with the IR camera data flow. This system can accommodate up to 8 video inputs.

All of the necessary DIII-D timing signals are directly sent to the interface chassis. As the VCRs are recording during a shot, the interface chassis sends the timing information to each of the VITC encoders. The encoder takes the timing information referenced to a vertical sync and encodes it into the video signal. During playback, the VITC decoder sends the recorded timing information it receives from a VCR back to the interface chassis. (The interface chassis was designed and fabricated by *Lawrence Livermore National Laboratory* and is based on the *Octagon Systems* 7100 processor.) This timing data is compared to the desired shot time sent by the AT-compatible microcomputer. A signal is sent to the TRAPIX when the correct field is present.

All devices shown in Fig. 5 are controlled by the interface chassis, which in turn is initialized by the AT-compatible microcomputer using an RS-232 interface with an ASCII protocol. If the TRAPIX/AT system is inoperative, the VCRs can still record incoming IR data and are controlled by the interface chassis microprocessor through the local control panel.

### C. Data processing

The TRAPIX can digitize the incoming IR video in real time (*i.e.*, 60 fields/second). However, if every one of the incoming IR video fields were totally digitized, then the digitized data collected for only a single shot would be enormous. Digitizing every field during an 11 sec shot would generate >30 MBytes of data per camera. To avoid an overload of data we digitize and keep only the data needed for analysis.

We have programmed the TRAPIX to digitize and process data from a pre-selected portion of the IR image. Just before IR data from any of the IR units is sent to the TRAPIX, the AT-compatible microcomputer sends instructions to the TRAPIX on how the IR data is to be processed. In a divertor case, for example, we digitize an outwardly-directed (radial) slice across the divertor. If data from the lower divertor were digitized in this manner, the radial slice might extend from major radius location 100 cm to major radius location 180 cm, as shown in Fig. 2(b). Toroidal symmetry is assumed. For the 11 sec shot mentioned above, the amount of processed data stored is less than 200 kBytes.

### III. SAMPLE RESULT

Proposals for next generation tokamaks, as CIT and ITER, use a "double-null" divertor configuration. An example of this configuration was shown in Fig. 2(b). Deduced from IR imaging data, Fig. 6(a) shows the total power flowing into the upper- and lower divertors for a standard double-null divertor. While the total heat flux that flows into the lower divertor is generally higher throughout most of the shot, this imbalance is not large. Figure 6(b) shows a radial profile of the heat flux to the upper- and lower divertors. Even though the maximum power density is somewhat higher for the lower divertor case, this difference is still small enough to give hope that these imbalances can be managed in future tokamaks.

The coverage afforded by the IR TV systems, coupled with rapid image processing, can provide very useful information on thermal activity inside the DIII-D vessel on a between-shot basis. Thermal monitoring coupled to fast processing of the

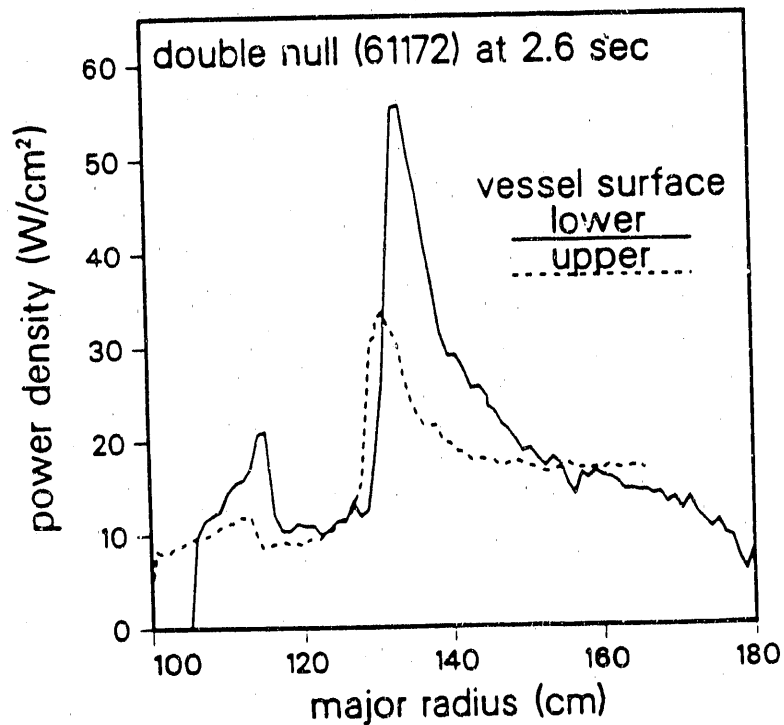
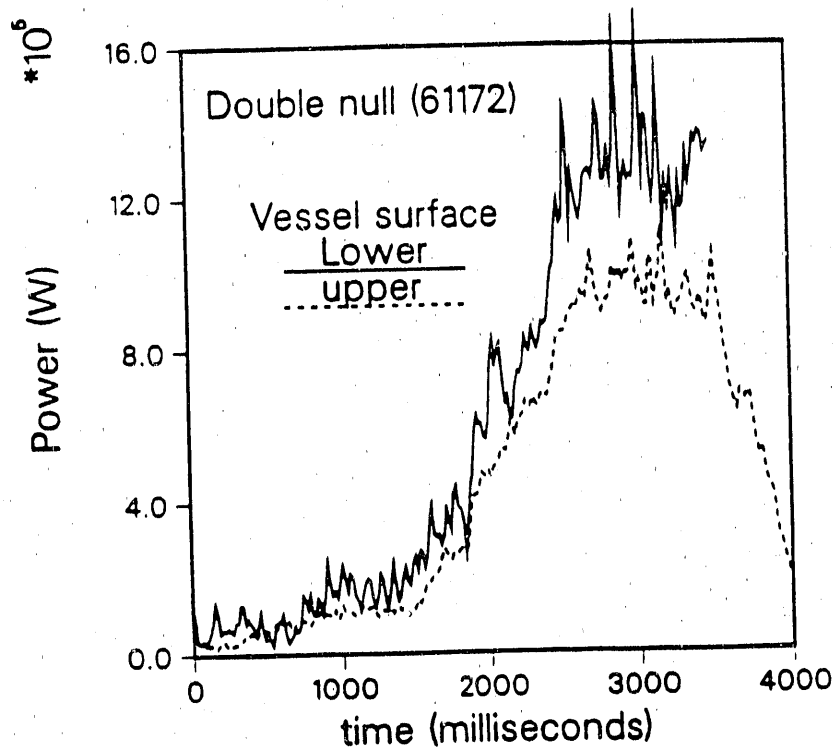

Fig. 6. Divertor heat flux for double-null divertor discharge. (a) total power to upper and lower divertors, (b) heat flux profiles at each divertor. Parameters:  $I_p = 0.9$  MA,  $B_T = 0.8$  T,  $P_{NBI} = 10$  MW, minor radius = 63 cm, and plasma elongation = 1.8.

IR data should also be an important diagnostic for next generation tokamaks, where high heat flux over several seconds duration are anticipated.

#### ACKNOWLEDGEMENT

This work was supported by the U.S. Department of Energy under Contract Nos. DE-AC03-89ER51114 and W-7405-ENG-48.

#### REFERENCES

- <sup>1</sup> M. A. Mahdavi, *et al.*, "Recent Results of Divertor Experiments in DIII-D," General Atomics Report GA-A18909, July 1989.
- <sup>2</sup> D. N. Hill, *et al.*, *Rev. Sci. Instrum.* **59**, 1878 (1988).

**- END -**

**DATE FILMED**

11 / 06 / 90

