

DISCLAIMER

This report was prepared as an account of work sponsored by an agency of the United States Government. Neither the United States Government nor any agency thereof, nor any of their employees, makes any warranty, express or implied, or assumes any legal liability or responsibility for the accuracy, completeness, or usefulness of any information, apparatus, product, or process disclosed, or represents that its use would not infringe privately owned rights. Reference herein to any specific commercial product, process, or service by trade name, trademark, manufacturer, or otherwise does not necessarily constitute or imply its endorsement, recommendation, or favoring by the United States Government or any agency thereof. The views and opinions of authors expressed herein do not necessarily state or reflect those of the United States Government or any agency thereof.

DISCLAIMER

Portions of this document may be illegible in electronic image products. Images are produced from the best available original document.

**PLANNING AND DESIGN OF ADDITIONAL
EAST MESA GEOTHERMAL
TEST FACILITIES
(PHASE 1B)**

VOLUME III – APPENDICES

R. O. Pearson



**SYSTEMS ENGINEERING AND INTEGRATION DIVISION
ONE SPACE PARK, REDONDO BEACH, CALIFORNIA 90278**

October 1976

**PREPARED FOR THE
ENERGY RESEARCH AND DEVELOPMENT ADMINISTRATION
DIVISION OF GEOTHERMAL ENERGY
UNDER CONTRACT E(04-3)-1140**

DISCLAIMER

This book was prepared as an account of work sponsored by an agency of the United States Government. Neither the United States Government nor any agency thereof, nor any of their employees, makes any warranty, express or implied, or assumes any legal liability or responsibility for the accuracy, completeness, or usefulness of any information, apparatus, product, or process disclosed, or represents that its use would not infringe privately owned rights. Reference herein to any specific commercial product, process, or service by trade name, trademark, manufacturer, or otherwise, does not necessarily constitute or imply its endorsement, recommendation, or favoring by the United States Government or any agency thereof. The views and opinions of authors expressed herein do not necessarily state or reflect those of the United States Government or any agency thereof.

REPRODUCTION OF THIS DOCUMENT IS UNLIMITED

MGW

CONTENTS

VOLUME III - APPENDICES

- A. - Petrophysical Study of Seven Wells in the East Mesa Area, Imperial County, California - INTERCOMP
- B. - Drilling Geothermal Wells, East Mesa, Imperial County, California - DRESSER

APPENDIX A

PETROPHYSICAL STUDY OF SEVEN WELLS
IN THE EAST MESA AREA,
IMPERIAL VALLEY, CALIFORNIA

Prepared for

TRW INC.

Prepared By

INTERCOMP Resource Development

and Engineering, Inc.

TABLE OF CONTENTS

	<u>Page</u>
A. INTRODUCTION	A-1
B. COMPUTATION METHODS	A-2
1. Task One: New Wells	A-2
● Core Data	A-2
● Porosity and Permeability Calculation	A-2
● Porosity Calculation Using the Shaly Sand Technique	A-4
● Selection of Sand/Shale Discriminators	A-5
● Zone Summaries	A-7
● Salinity Computation in Republic Geothermal 38-30	A-8
2. Task Two: Old Wells	A-9
● Magma Sharp	A-9
● Border Oil and Gas Barbara	A-11
● Texaco Grupe Engebretson	A-11
● American Petrofina #27	A-11
C. COMMENTS AND RECOMMENDATIONS	A-13
D. DEFINITIONS	A-14
E. REFERENCES	A-15
F. TABLES	
G. FIGURES	

LIST OF TABLES

TABLE

1	Republic Geothermal Wells 38-30 16-29 and 18-28, Input Parameters for Shaly Sand Model
2	Republic Geothermal 38-30 Run #1 Zone Summaries
3	Republic Geothermal 38-30 Run #2 Zone Summaries
4	Republic Geothermal 16-29 Zone Summaries
5	Republic Geothermal 18-28 Zone Summaries
6	Interval Salinities and SP Cutoff for Old Wells
7	Magma Sharp Zone Summaries
8	Border Barbara Zone Summaries
9	Texaco Grupe Engebretson #1 Zone Summaries
10	American Petrofina #27 Δ tsh and SP Cutoffs
11	American Petrofina #27 Zone Summaries

LIST OF FIGURES

FIGURE

- 1 Crossplot of Core Porosity vs Log Permeability
- 2 Crossplot of Log Horizontal Permeability vs Log Vertical Permeability
- 3 Crossplot of ODEN vs PHI Republic Geothermal 38-30
- 4 Crossplot of ODEN vs PHI in Sandstones Only
- 5 Crossplot of ODEN vs PHI with Gamma on Third Axis - Republic Geothermal 38-30
- 6 Crossplot of ODEN vs PHI with Vclay on Third Axis Republic Geothermal 38-30
- 7 Crossplot of Density Porosity vs CNL Porosity in Sandstone Units Republic Geothermal 38-30
- 8 Crossplot of Density Porosity vs CNL Porosity with Gamma on Third Axis Republic Geothermal 38-30
- 9 Crossplot of Density Porosity vs CNL Porosity with Caliper on Third Axis Republic Geothermal 38-30
- 10 Crossplot of Density Porosity vs CNL Porosity with Resistivity on Third Axis Republic Geothermal 38-30
- 11 Crossplot of Gamma vs Vclay Republic Geothermal 38-30
- 12 Crossplot of SP vs Vclay Republic Geothermal 38-30
- 13 Crossplot of SP vs Gamma Republic Geothermal 38-30

LIST OF FIGURES - Cont'd

FIGURE

- 14 Histogram of Gamma Republic
Geothermal 38-30 5200'-6500'
- 15 Crossplot of Porosity vs Depth
Sands Only. Republic Geothermal
38-30
- 16 Crossplot of Log Permeability vs
Depth Sands Only. Republic
Geothermal 38-30
- 17 Crossplot of SP vs Resistivity
4620'-6000' Magma Sharp
- 18 Histogram of SP 4620'-6000' Magma
Sharp
- 19 Crossplot of Δt vs Depth in Shales
Only. American Petrofina #27

A. INTRODUCTION

This report contains the results of a petrophysical study performed on seven wells in the East Mesa area of the Imperial Valley of California. The wells were drilled on and around the geothermal anomaly that constitutes the East Mesa Field.

The study was subdivided into two tasks, the first dealing with three recently drilled wells, the second dealing with four older wells that lie off the geothermal anomaly. The three new wells are: Republic Geothermal 38-30, Republic Geothermal 16-29 and Republic Geothermal 18-28. The older wells are: Magma Sharp, Border Barbara, American Petrofina #27 and Texaco Grupe-Engbretson.

In each case the objective of the petrophysical study was to determine porosities, permeabilities and salinities in requested intervals, together with the selection of the best sand/shale discriminator. The computed results have been reported in table and listing form to show average values of porosity, horizontal and vertical permeabilities together with gross interval, net sand, percent sand and darcy-feet tabulations, layered in 250' intervals throughout each well.

B. COMPUTATION METHODS

1. Task One: New Wells

● Core Data

Prior to this study a core/log transform was developed for TRW in the Bureau of Reclamation 5-1 well for use in analyzing the five Bureau wells in this area. The transform was derived from crossplotting core porosity with the density log in well 5-1 and, permeability transforms were also generated by crossplotting $\log_{10} K_{(H)}$ vs. porosity and $\log_{10} K_{(H)}$ vs. $\log_{10} K_{(V)}$.

In the present study consideration was given to adding core data from the Texaco Grupe-Engebretson well to the previous data and generating a new transform. This was done and the resulting transforms were little different from the existing ones (Figs. 1&2). It was felt that, since correlations between these two wells were at best doubtful, these two cores may not originate from the same geological horizon and that mixing of these data may be invalid. This, together with the similarity of transforms led to the adoption of the previously generated transforms for use in this study.

● Porosity and Permeability Calculation

As INTERCOMP's exposure to the log data in the East Mesa area has increased, it has become clear that at least three major geological environments exist in the sedimentary record of this area and are related to the fluvial, deltaic and lacustrine genesis of the sediments that are a result of deposition from the Colorado River. Salinities of the associated formation waters vary from as little as 800 ppm NaCl to 15-20,000 ppm NaCl depending most probably on the genesis of the sands.

It is, therefore, somewhat dangerous to apply a porosity transform developed in one sand to 10,000 feet of sand in a well where environmental changes are expected, even though, when using the density log, the errors may be small. Therefore, in

this study, a comparison was made of log derived porosities using a shaly sand technique with porosities derived by using the density log together with the previously mentioned porosity transform, namely:

$$\phi = 1.57 - .590 \rho_{\text{bulk}} \quad (1)$$

Porosities derived from this transform will be referred to as ODEN and porosities from the shaly-sand technique referred to as PHI. The results of the two methods were compared in Republic Geothermal 38-30.

Figures 3-6 illustrate a sequence of crossplots in which ODEN is plotted on the y axis and PHI on the x axis. Figure 3 shows that for porosities less than approximately 27% ODEN is optimistic compared to PHI.

Figure 4 is a repeat of Figure 3 with shales controlled out using an SP cut off of 20 m.v. (baseline removed). A much better ODEN/PHI relationship is obtained, but still ODEN appears optimistic in the porosity range from 18-27%.

Figure 5 again crossplots ODEN and PHI in sands only, but now the gamma curve is plotted on the Z (third) axis. (Note: Gamma Scale at bottom of plot 0-110 API). The clean sands (4s) can be seen plotting on the 1:1 line with gamma counts increasing away from the 1:1 line.

In Figure 6 the gamma curve is replaced by Vclay (volume of clay) computed in the shaly sand technique. As in Figure 5 the points falling off the 1:1 line appear to be shaly.

It is clear from these crossplots that ODEN is optimistic in shaly sands and that although effective porosities exist in such sands, they are probably lower than the transform derived porosity would compute. This, together with the risk involved in applying this transform to genetically different sediments led INTERCOMP to utilize the shaly sand technique in all wells containing modern log suites i.e. CNL/FDC combinations.

It is probable that the cored sands used in transform development were clean and clay free thus making it impossible to incorporate the effects of shaliness into a transform. It may be that even if some clay had existed in the core, it may have dried out prior to analysis, allowing erroneously high values of effective porosity to be measured. From a permeability standpoint the core derived permeability vs. porosity relationship were used in all computations. Since good porosity values could be obtained, it was felt that the permeabilities so derived would be quite representative (Equations 2A and 2B).

$$\log K_{(H)} = 13.614\phi - 1.8126 \quad (2A)$$

$$\log K_{(V)} = .93987 \log K_{(H)} - .04363 \quad (2B)$$

It has been INTERCOMP's previous experience that permeabilities derived from logs and cores in the East Mesa area, as in many other areas, have been consistently high when compared to pressure build-up derived values. It has been customary in many industry studies to average horizontal permeability arithmetically. However, since our transform relates linear porosity to the logarithm of permeability, if one enters the equation with an average porosity for a given zone the average permeability derived will be the geometric not the arithmetic average. INTERCOMP has presented the geometric average in the tables of results for each well and has noted that these averages are in reasonable agreement with the build-up permeabilities.

- Porosity Calculation Using the Shaly Sand Technique

The shaly sand model primarily employs the use of the CNL and FDC logs to compute porosity (ϕ) (Eq. 3), volume of clay (V_{Cl}) and shale (V_{SH}) and silt index (SI) together with a resistivity log to compute shale resistivity (R_{SH}) and saturation using the Simandoux equation (Eq. 4).

$$\phi = \frac{\phi^D \cdot \phi^N_{cl} - \phi^N \cdot \phi^D_{cl}}{\phi^N_{cl} - \phi^D_{cl}} \quad (3)$$

$$\frac{1}{R_t} = \frac{V_{SH}}{R_{SH}} \cdot S_w + \frac{\phi^m}{A \cdot R_w (1 - V_{SH})} \cdot S_w^n \quad (4)$$

Crossplots of density and neutron porosities were made in sandstone units to determine neutron and density clay points together with silt indices (Fig. 7-9). A constant silt index was chosen for each layer represented by a series of crossplots. R_{SH} was determined by adding the resistivity log to the third axis of the CNL/FDC crossplots (Fig. 10) and reading the value of the resistivity in the area of the shales. This value together with silt index and V_{SH} was required only when computing salinities from equation (4).

A sequence of crossplots from Republic Geothermal 38-30 will serve to illustrate this technique (Figs. 7-10).

If an obvious clay point was not present in some intervals the point was derived by finding the intersection of the quartz-shale line with the theoretical dry clay - 100% porosity line.

A summary of the clay points and other input parameters for wells 16-29 and 18-28 can be found in Table 1 and the crossplots used in Appendix A. The selection of crossplot interval for parameter definition in each well was tempered to meet some of the more apparent geological changes-namely the major environments referred to earlier.

- Selection of Sand/Shale Discriminators

Sand/shale discriminators were more abundant in the wells with CNL/FDC logs than in the older wells without these logs. The older wells will be discussed later. There were three discriminators evaluated, namely the SP and gamma logs together with the Vclay trace. Probably the most sensitive indicator of shaliness is volume of shale (V_{SH}) or in our case, since silt index remains constant for a given layer, volume of clay (V_{Cl}). This is especially true since Vclay increases at the expense of effective porosity. There are however some sections

of these wells in which, due to bad hole condition, especially severe mud cake build-up, the CNL, FDC or both logs respond erratically and yield spurious Vclay calculations. Thus a dual cutoff system was sought in which Vclay values could be replaced in discriminating function by another log curve. Both the gamma and SP logs display an excellent correlation coefficient when crossplotted with Vclay (Figs. 11 and 12) and have an excellent correlation with each other (Fig. 13). However, the SP is subject to changes in formation water salinities and is poorly recorded in both 16-29 and 18-28. Hence, the gamma was chosen as the secondary cut off in the three Republic wells. At first this created some concern since California sediments are reknown for their feldspathic content and hence problematic gamma responses. However, on studying both the crossplots mentioned above and some sample descriptions provided by TRW, it became clear that these sediments are relatively free of potassium feldspar, the latter never reading more than 10% of the sediment and usually being below 5-10%.

In summary, the method of cut off application was as follows:

1. The Vclay equivalent of 50% Vshale was computed by substitution in Equation (5).

$$V_{SH} = \frac{V_{C1}}{1-SI} \quad (5)$$

2. A gamma cut off equivalent to the Vclay cut off was chosen from the crossplot (Fig. 11). A gamma histogram (Fig. 14) was used in conjunction with this crossplot and if a group of points fell within the Vclay cutoff but outside the gamma cutoff the interval was reexamined on the field prints to determine if a genuine increase in feldspathic content had occurred. If so the gamma cutoff was raised to a point between the anomalous sand and the typical shale response of the gamma log.

3. The two cutoffs so derived were both used to discriminate the sands from shales.

The crossplotting and parameter selection were performed in layers of unequal thickness from top to bottom. The thicknesses of the layers were determined by examination of the logs from a geological environment standpoint. Sometimes the initial interval would be too large to determine good clay points and silt indices. In this event replotting was required until a suitable layer was attained. The layer shown in the example is 1300' in thickness. A summary of the clay points and silt indices can be found in Table 1.

- Zone Summaries

During the computation of the zone summaries the cutoffs described were applied to determine net sand. The computed porosities and permeabilities were then averaged within the sands. Any porosities and associated permeabilities, greater than 40% (due to washouts etc.) were reset to the average value for a given layer.

Crossplots used in parameter selection for wells 38-30, 16-29 and 18-28 are included in Appendix A. The zone summaries for Republic Geothermal Wells 38-30 (runs 1&2), 16-29 and 18-28 are presented in Tables 2-5. Percent sand is merely net sand/gross interval x 100. The column headed Darcy-ft. is the result of net sand x $\bar{K}_{(H)}$ geom./1000.

The CNL of Run #1 in well 38-30 was considered unreliable and porosity was computed using the density log together with the previously described transform.

It was concluded from crossplots on well 18-28 that the uncompensated density log was miscalibrated by two porosity units. Two porosity units were, therefore, subtracted from the density log prior to final crossplotting. The two sets of crossplots are shown in Appendix A.

During the processing of Republic Geothermal 38-30, crossplots of porosity and permeability versus depth were made. These are presented in Figures 15 and 16 for your reference.

- Salinity Computation in Republic Geothermal 38-30

Salinities over the required intervals in Republic Geothermal 38-30 were computed from the Simandoux equation (4) and are presented in Appendix B.

2. TASK TWO: OLD WELLS

The objectives of this phase of the study were the same as in Task 1, namely to evaluate porosity, permeability, salinity and sand/shale discriminators.

The available log suites contained no CNL/FDC or gamma traces hence the SP became the best choice as a sand/shale discriminator in all four wells. The only porosity log was a sonic run in the American Petrofina #27 well and in this case it was possible to compute salinities using resistivity and porosity traces. The remaining three wells were evaluated in similar fashion and will be discussed first.

● Magma Sharp

This well has an IES log with a badly drifting SP. The baseline drift was first removed and an attempt made at computing salinities from the SP using the following equation:

$$SP = - (60 + .133T^{\circ}F) \times \log \left(\frac{R_{mf}}{R_w} \right) \quad (6)$$

To compare results of SP derived salinities with those derived from resistivity and porosity logs, similar computations were made in Run 2 of Republic Geothermal 38-30. As expected, agreement between salinities was poor, but it was hoped that by crossplotting the two salinities a correction factor could be obtained that would enable us to use the SP data. This end was not achieved. The lack of success could be attributed to many things but probably results from a combination of problems. Firstly, the recorded Rmfs may be in error. However this would produce a consistent error in one direction and this was not the case. Secondly, shaliness may cause problems, but this was overcome by computing only in the cleaner sands. Probably the cause of the problem is two-fold: the effects of streaming potential in the shallower sands together with the serious problems associated with fresh-water bearing sands. In the latter case, the salinities derived cannot be considered as

predominately NaCl related since at salinities below 10000 ppm other ions such as Mg, Ca and SO₄ become important.

It was decided that salinities of quantitative use could not be obtained from the SP without an effort beyond the scope of this study and that the best approach was to histogram the SP response and crossplot the SP with the resistivity log in an effort to define intervals of changing salinity that might correlate with the Republic Geothermal wells where salinities are better known and fall into three major zones - an upper zone of 10-15000 ppm, a middle zone of 1-4000 ppm , and a lower zone of 6-10000 ppm.

Once the salinity was estimated a continuous R_w trace was generated and used with the resistivity log to generate porosity from equation (7)

$$\phi = m \sqrt{\frac{A \times R_w}{R_t}} \quad (7)$$

$$A = 1.13$$

$$m = 1.73$$

Permeability was derived from porosity by using the transforms previously described. The crossplots of SP vs. resistivity and the histograms of the SP were also used to select sand/shale cutoffs. As can be seen in Figure 17 distinct groups of data form in both the sand and shale areas and by using the SP histogram (Fig. 18) a point can be selected between the groups and used as a cut off with some reliability. The crossplots used to generate input parameters in this and other wells in Task 2 can be found in Appendix C. The salinity inputs can be found in Table 6.

The zone summaries for the Magma Sharp well are shown in Table 7.

- Border Oil and Gas Barbara
- Texaco Grupe Engebretson

These two wells can be discussed together since both have old logs and processing was similar in each case. Salinities were again approximated by correlating in to the known pattern in nearby wells.

The same type of crossplots were made as described for the Magma Barbara well. The input data for both of these wells is reported in Table 6 and the zone summaries for the Barbara well and the Texaco well are reported in Tables 8 and 9, respectively. Since these logs are very qualitative the results should be viewed in the same light - especially in the case of the Texaco well.

- American Petrofina #27

American Petrofina #27 has both an IES and Sonic log run in the well. This combination provided a means of computing porosity (from the sonic) permeability and salinity. The SP was used as the sand/shale indicator after removal of the baseline drift. The sand/shale cutoffs are listed in Table 10.

The sonic log was corrected for compaction effects by crossplotting the sonic response versus depth in the shales only (Fig. 19). Using the lines drawn on this plot a Δt shale trace was constructed. Using this trace in equation (8), the porosity was computed

$$\phi = \frac{\Delta t_{log} - \Delta t_{ma}}{\Delta t_{fl} - \Delta t_{ma}} \times \frac{100}{\Delta t_{sh}} \quad (8)$$

where $\Delta t_{ma} = 56$ micro secs.
 $\Delta t_{fl} = 189$ micro secs.

The Δt shale trace input values are listed in Table 10. Salinities were computed using porosities from the sonic log and resistivities from the IES log. Equation (9) was

used for this purpose. The equation was solved for R_w then R_w was converted to salinity.

$$S_w^n = \frac{F \times R_w}{R_t} \quad (9)$$

assumed: $n = 2, F = 1.13/\phi^{1.73}$

The resulting salinities can be found in Appendix B. The porosity and permeability summaries are displayed in Table 11.

C. COMMENTS AND RECOMMENDATIONS

The full log suites in parts of the Republic Geothermal wells have enabled us to make a reasonable attempt at quantifying parameters such as porosity, permeability and salinity. However, even this interpretation has been hampered by poor borehole conditions, primarily severe mud cake build-up. The complex geology and associated faulting alone should bear witness to the need for good logs for use in correlation work. The presence of shaly sands and fresh formation waters points to another and more urgent need for a full log suite. If the right logs are run in the East Mesa Area (Dual Induction, FDC/CNL and possibly Sonic) then a good mud program should be maintained to allow good log responses to be outlined.

With 10,000' of sediment, ranging genetically from deltaic through fluviatile to lacustrine deposition it is also important from both a geological and log analysis standpoint to cut full hole cores wherever possible. These cores should be analyzed for porosity, permeability, grain density and where possible shaliness indications such as cation exchange capacity. The cutting and analyzing of cores is essential in an area such as East Mesa, where adverse logging conditions are apparent (high temperatures), in order that calibrated log responses may be obtained and the log data validated.

Due to the size of Appendices A-C it was decided to exclude them from the reports per se and present them to TRW as separate documents.

D. DEFINITIONS

Δt_{log}	=	interval transit time measured from log
Δt_{fl}	=	fluid transit time in micro secs/foot
Δt_{ma}	=	matrix transit time in micro secs/foot
Δt_{sh}	=	transit time of shale in micro secs/foot
ϕ	=	porosity
$\bar{\phi}$	=	average porosity
ϕ_D	=	porosity from density log
ϕ_N	=	porosity from neutron log
ϕ_{cl}^D	=	density reading for clay, in porosity units
ϕ_{cl}^N	=	neutron porosity response in clay
R_t	=	estimate of true formation resistivity
V_{SH}	=	volume of shale
R_{SH}	=	resistivity of shale
R_w	=	resistivity of formation water (at given temperature)
S_w	=	water saturation
S_o	=	oil saturation
ρ_{ma}	=	matrix density
ρ_{bulk}	=	bulk density recorded on log
F	=	formation resistivity factor
$K_{(H)}$	=	horizontal permeability in millidarcies
$K_{(V)}$	=	vertical permeability in millidarcies
\bar{K}	=	average permeability
m	=	slope in formation factor
A	=	constant in formation factor
SI	=	silt index
R_{mf}	=	resistivity of mud filtrate

E . REFERENCES

1. INTERCOMP Inc. Petrophysical Evaluation of East Mesa Geothermal Wells, November 1975 (Prepared for TRW Inc.).
2. U. S. Dept. of the Interior, Bureau of Reclamation, Geothermal Resource Investigation; Test Well Mesa 6-1; Special Report, February, 1973.
3. Log Interpretation Fundamentals, Dresser Atlas Division, Dresser Industries, Inc., 1975.

F. TABLES

TABLE I
 REPUBLIC GEOTHERMAL WELLS 30-38, 16-29 AND 18-28
 INPUT PARAMETERS FOR SHALY/SAND MODEL

<u>WELL</u>	<u>INTERVAL</u>	<u>ϕ_{NC1}</u>	<u>ϕ_{DC1}</u>	<u>SI</u>	<u>R_{SH}</u>
38-30	5200-6500	.410	.112	.23	2.4
	6500-7300	.420	.136	.26	2.2
	7300-8250	.405	.112	.37	3.8
	8250-8900	.330	.001	.41	5.0
16-29	4800-5925	.400	.112	.32	3.0
	5925-7050	.360	.06	.42	3.5
	7050-7900	.380	.08	.36	3.5
18-28	5100-6400	.400	.112	.28	2.0
	6400-7900	.370	.065	.38	2.2

TABLE 2

REPUBLIC GEOTHERMAL 38-30 Run #1
ZONE SUMMARIES

<u>Interval</u>	<u>Gross</u>	<u>Net Sand</u>	<u>% Sand</u>	<u>$\bar{\phi}$</u>	<u>$\bar{K}_{(H)}\text{Arith}$</u>	<u>$\bar{K}_{(H)}\text{Geo}$</u>	<u>$\bar{K}_{(v)}$</u>	<u>Darcy-Ft</u>
1350-1500	151	125	83	.35	1174	913	549	114
1501-1750	250	223	89	.34	1023	757	460	169
1751-2000	250	140	56	.32	756	456	286	64
2001-2250	250	155	62	.34	1064	721	439	112
2251-2500	250	166	66	.31	573	321	205	53
2501-2750	250	161	64	.31	467	256	166	41
2751-3000	250	214	86	.36	1645	1315	772	281
3001-3250	250	214	86	.33	897	534	331	114
3251-3500	250	171	68	.28	149	102	70	17
3501-3750	250	181	72	.29	322	134	91	24
3751-4000	250	166	66	.31	473	243	159	40
4001-4250	250	111	44	.31	714	286	184	32
4251-4359	109	63	58	.30	283	180	119	11
4360-4500	141	82	58	.29	248	123	83	10
4501-4750	250	195	78	.30	432	186	123	36
4751-5000	250	189	76	.28	367	115	78	22
5001-5200	250	162	81	.30	595	205	135	33

TABLE 3

REPUBLIC GEOTHERMAL RUN #2
ZONE SUMMARIES

<u>Interval</u>	<u>Gross</u>	<u>Net Sand</u>	<u>% Sand</u>	<u>$\bar{\phi}$</u>	<u>$\bar{K}_{(H)Arith}$</u>	<u>$\bar{K}_{(H)Geo}$</u>	<u>$\bar{K}_{(v)}$</u>	<u>Darcy-Ft</u>
5251-5500	250	210	84	.30	570	187	123	39.3
5501-5750	250	201	80	.23	101	22	17	4.4
5751-6000	250	162	65	.23	63	23	17	3.7
6001-6250	250	183	73	.28	312	90	62	16.5
6251-6500	250	227	91	.31	645	266	172	60.4
6501-6750	250	219	88	.31	826	229	147	50.2
6751-7000	250	153	61	.25	287	36	26	5.5
7001-7250	250	76	30	.16	9	2	2	.15
7251-7500	250	86	34	.19	17	6	5	.52
7501-7700	200	115	58	.18	14	5	4	.58
7701-8000	300	122	41	.22	106	18	13	2.2
8001-8250	250	93	37	.11	1.5	.6	.5	.06
8251-8500	250	111	44	.10	.9	.4	.4	.04
8501-8750	250	63	25	.11	16	.6	.6	.04
8751-8900	150	26	17	.07	.2	.1	.1	.003

TABLE 4

REPUBLIC GEOTHERMAL 16-29
ZONE SUMMARIES

<u>Interval</u>	<u>Gross</u>	<u>Net Sand</u>	<u>% Sand</u>	<u>ϕ</u>	<u>$\bar{K}_{(H)}$ Arith</u>	<u>$\bar{K}_{(H)}$ Geo</u>	<u>$\bar{K}_{(v)}$</u>	<u>Darcy-Ft</u>
4800-5000	250	175	70	.26	190	54	39	9.45
5001-5250	250	182	73	.25	130	43	31	7.83
5251-5500	250	181	72	.22	56	18	13	3.26
5501-5750	250	206	82	.22	33	15	12	3.09
5751-5925	174	125	72	.22	81	16	12	2.00
5926-6000	250	52	21	.27	140	64	45	3.33
6001-6250	250	211	84	.25	112	44	32	9.28
6251-6500	250	219	88	.27	263	78	55	17.08
6501-6750	250	175	70	.25	95	39	28	6.83
6751-7000	250	163	65	.19	16	6	5	0.98
7001-7050	50	3	6	.14	2	1	1	0.003
7051-7250	200	40	20	.14	32	1	1	0.04
7251-7500	250	143	57	.22	37	13	10	1.86
7501-7750	250	155	62	.21	54	11	0	1.71
7751-7900	150	90	60	.22	34	16	12	1.44

A-20

TABLE 5
REPUBLIC GEOTHERMAL 18-28
ZONE SUMMARIES

<u>Interval</u>	<u>Gross</u>	<u>Net Sand</u>	<u>% Sand</u>	<u>$\bar{\phi}$</u>	<u>$\bar{K}_{(H)}$ Arith</u>	<u>$\bar{K}_{(H)}$ Geo</u>	<u>$\bar{K}_{(v)}$</u>	<u>Darcy-Ft</u>
5100-5250	250	88	35	.25	306	34	25	2.99
5251-5500	250	226	90	.29	458	146	98	32.9
5501-5750	250	226	90	.29	658	134	90	30.3
5751-6000	250	193	77	.29	529	136	92	26.3
6001-6250	250	183	73	.22	42	15	29	2.7
6251-6400	250	59	24	.23	86	18	55	1.1
6401-6500	100	28	28	.22	30	17	21	.48
6501-6750	250	202	81	.22	29	16	21	3.2
6751-7000	250	136	54	.22	127	18	14	2.4
7001-7250	250	84	34	.23	213	24	18	2.0
7251-7500	250	94	38	.27	994	85	59	8.0
7501-7750	250	92	36	.22	198	13	10	1.2
7751-7900	150	55	37	.15	2	2	1	.1

TABLE 6

INTERVAL SALINITIES AND SP CUTOFF FOR OLD WELLS

<u>WELL</u>	<u>INTERVAL</u>	<u>SALINITY</u>	<u>SP CUTOFF (SAND > m.v.)</u>
Magma Sharp	100- 4620	11,000 ppm	14 m.v.
	4621- 6050	3,800 ppm	14 m.v.
Border Barbara	120- 800	5,000 ppm	8 m.v.
	801- 2450	10,000 ppm	25 m.v.
	2451- 5600	5,000 ppm	8 m.v.
	5601- 7250	2,000 ppm	12 m.v.
	7251- 8010	6,000 ppm	12 m.v.
Texas Grupe Engebretson	2000- 4200	10,000 ppm	18 m.v.
	4201-11450	4,000 ppm	19 m.v. (4201-7000) 24 m.v. (7000-9010) 3 m.v. (9011-11450)

TABLE 7
MAGMA SHARP
ZONE SUMMARIES

<u>Interval</u>	<u>Gross</u>	<u>Net Sand</u>	<u>% Sand</u>	<u>$\bar{\phi}$</u>	<u>$\bar{K}_{(H)Arith}$</u>	<u>$\bar{K}_{(H)Geo}$</u>	<u>$\bar{K}_{(v)}$</u>	<u>Darcy-Ft</u>
1251-1500	250	51	20	.22	17	15	11	.76
1501-1750	250	77	31	.23	38	22	16	1.7
1751-2000	250	31	12	.22	22	18	14	.56
2001-2250	250	90	36	.27	107	75	52	6.8
2251-2500	250	138	55	.29	275	150	100	21
2501-2750	250	162	65	.31	368	253	164	41
2751-3000	250	160	64	.30	308	175	116	28
3001-3250	250	142	57	.33	714	482	301	68
3251-3500	250	190	76	.33	595	458	287	87
3501-3750	250	171	68	.33	678	509	317	87
3751-4000	250	150	60	.31	405	270	175	41
4001-4250	250	117	47	.29	290	147	98	17.2
4251-4500	250	155	62	.26	127	48	34	7.4
4501-4620	120	99	83	.25	83	37	27	3.7
4621-4750	130	70	54	.37	2160	1980	1135	139
4751-5000	250	154	62	.35	914	780	473	120
5001-5250	250	170	68	.33	1010	490	286	83
5251-5500	250	128	51	.33	1397	464	290	59
5501-5750	250	210	84	.30	429	199	131	42
5751-6000	250	213	85	.28	216	115	78	24

A-23

TABLE 8

BORDER BARBARA
ZONE SUMMARIES

<u>Interval</u>	<u>Gross</u>	<u>Net Sand</u>	<u>% Sand</u>	<u>$\bar{\phi}$</u>	<u>$\bar{K}_{(H)}$ Arith</u>	<u>$\bar{K}_{(H)}$ Geo</u>	<u>$\bar{K}_{(v)}$</u>	<u>Darcy-Ft</u>
120- 500	381	361	95	.33	1032	454	279	164
501- 800	300	266	89	.34	895	595	361	158
801-1000	250	136	54	.38	2873	2686	1467	365
1001-1250	250	105	42	.39	3850	3823	2106	401
1251-1500	250	175	70	>.40	>4000	>4000	>4000	>700
1501-1750	250	182	73	.39	2804	2706	1522	492
1751-2000	250	232	93	.38	2469	2116	1208	491
2001-2250	250	106	42	.36	1411	1158	686	123
2251-2450	200	120	60	.29	195	126	85	15
2451-2500	50	25	50	>.40	>4000	>4000	>4000	>700
2501-2750	250	206	82	.36	1872	1356	795	279
2751-3000	250	228	91	.39	3295	3211	1788	732
3001-3250	250	164	66	.36	1833	1430	836	234
3251-3500	250	188	75	.32	611	396	250	74
3501-3750	250	164	66	.37	1977	1528	890	251
3751-4000	250	173	69	.32	932	404	255	70
4001-4250	250	182	73	.31	480	284	183	52
4251-4500	250	244	98	.34	1085	668	409	163
4501-4750	250	172	69	.28	570	110	75	18.9
4751-5000	250	223	89	.26	225	50	36	11.2
5001-5250	250	206	82	.31	591	284	183	59
5251-5500	250	205	82	.24	105	31	29	6.4
5501-5600	100	70	70	.24	100	27	20	1.9
5601-5750	250	40	16	.38	2230	2056	1176	82
5751-6000	250	135	54	.36	1319	1135	664	153
6001-6250	250	151	60	.36	2128	1339	711	202
6251-6500	250	141	56	.36	1928	1243	733	175
6501-6750	250	209	84	.22	96	14.2	11	3.0
6751-7000	250	156	62	.30	331	200	132	31.2
7001-7250	250	148	60	.27	96	66	47	9.8
7251-7500	250	220	88	.15	56	1.7	1.5	.37
7501-7750	250	167	67	.10	.40	.37	.36	.06
7751-8000	250	159	64	.12	.86	.75	.69	.12
8001-8010	10	8	80	.14	1.5	1.4	1.3	.01

TABLE 9
 TEXACO GRUPE ENGBRETSON #1
 ZONE SUMMARIES

<u>INTERVAL</u>	<u>GROSS</u>	<u>NET SAND</u>	<u>% SAND</u>	<u>$\bar{\phi}$</u>	<u>$\bar{K}_{(H)}$ Arith</u>	<u>$\bar{K}_{(H)}$ Geo</u>	<u>$\bar{K}_{(v)}$</u>	<u>Darcy-Ft</u>
2000-2250	251	72	29	.36	1591	1222	721	88
2251-2500	250	108	43	.32	533	350	222	38
2501-2750	250	38	15	N.R.	-	-	-	-
2750-3000	250	105	42	.33	885	463	290	49
3001-3250	250	43	17	.39	3411	3332	1850	143
3251-3500	250	23	9	.36	2040	1335	783	31
3501-3750	250	44	18	.39	2855	2734	1536	120
3751-4000	200	63	25	.36	1587	1330	780	84
4001-4200	300	132	66	.38	2516	2424	1361	320
4201-4500	250	114	38	.39	3257	3207	1785	366
4501-4750	250	112	45	.38	2377	2326	1320	261
4751-5000	250	140	56	.38	2307	2084	1190	292
5001-5250	130	158	63	.34	882	675	413	107
5251-5380	120	91	70	.37	1769	1442	842	131
5381-5500	250	61	51	N.R.	-	-	-	-
5501-5750	250	97	39	.34	1286	729	420	71
5751-6000	250	150	60	.36	1468	1071	637	161
6001-6250	250	103	41	.36	1490	1176	680	121
6251-6500	250	129	52	.30	605	180	119	23
6501-6750	250	158	63	.29	592	141	95	22
6751-7000	250	27	11	.36	1633	1145	678	31
7001-7250	250	105	42	.30	550	168	112	17.6
7251-7500	250	134	54	.28	225	100	69	13.4
7501-7750	250	123	49	.28	234	105	72	12.9
7751-8000	250	112	45	.30	370	182	120	20
8001-8250	250	201	80	.25	125	34	25	6.8
8251-8500	250	139	56	.25	117	43	31	6.0
8501-8750	250	112	45	.23	89	19	14	2.1
8751-9000	250	134	54	.29	360	123	83	16.5
9001-9010	10	0	0	0	0	0	0	-
9011-9250	240	104	43	.29	363	154	103	16
9251-9500	250	187	75	.25	135	35	25	6.5

A-25

TABLE 9

TEXACO GRUPE ENGBRETSON #1 - Cont'd
 ZONE SUMMARIES

<u>INTERVAL</u>	<u>GROSS</u>	<u>NET SAND</u>	<u>% SAND</u>	<u>$\bar{\phi}$</u>	<u>$\bar{K}_{(H)Arith}$</u>	<u>$\bar{K}_{(H)Geo}$</u>	<u>$\bar{K}_{(v)}$</u>	<u>Darcy-Ft</u>
9501-9750	250	208	83	.26	78	53	37	11
9751-10000	250	194	78	.23	37	20	15	3.9
10001-10250	250	212	85	.22	32	17	13	3.6
10251-10500	250	150	63	.21	30	10	8	1.6
10501-10750	250	99	40	.22	45	17	13	1.7
10751-11000	250	130	52	.21	33	12	9	1.6
11001-11250	250	160	64	.19	10	6	5	1.0
11251-11420	170	93	55	.17	6	3	3	.28

N.R. = No reading (unable to calculate averages due to excessively high porosities: >40%)

TABLE 10
 AMERICAN PETROFINA #27
 Δ tsh and SP Cutoffs

<u>INTERVAL</u>	<u>Δtsh</u>	<u>SP Cutoff</u>
110- 1990	175-155	10 m.v.
1991- 2980	155-135	9 m.v.
2981- 4960	135-110	8 m.v.
4961- 6100	110-103	11 m.v.
6101- 7730	103-100	12 m.v.
7731- 9500	100-100	9 m.v.
9500-10050	100-100	9 m.v.

TABLE 11
 AMERICAN PETROFINA #27
 ZONE SUMMARIES

<u>Interval</u>	<u>Gross</u>	<u>Net Sand</u>	<u>% Sand</u>	<u>$\bar{\phi}$</u>	<u>$\bar{K}_{(H)}$ Arith</u>	<u>$\bar{K}_{(H)}$ Geo</u>	<u>$\bar{K}_{(v)}$</u>	<u>Darcy-Ft</u>
1751-1990	240	216	90	.30	618	219	143	47
1991-2000	10	8	80	.35	919	828	500	6.6
2001-2250	250	209	84	.36	1523	1062	632	222
2251-2500	250	231	92	.35	1562	936	561	216
2501-2750	250	191	76	.35	1139	845	510	161
2751-2980	230	211	92	.32	675	397	251	84
2981-3000	20	2	10	.31	255	244	159	.49
3001-3250	250	235	94	.35	1351	1028	604	242
3251-3500	250	230	92	.35	1437	872	525	201
3501-3750	250	218	87	.35	1274	968	579	211
3751-4000	250	219	88	.34	835	583	359	128
4001-4250	250	221	88	.32	603	394	249	87
4251-4500	250	190	76	.33	970	567	350	108
4501-4750	250	143	57	.33	812	460	288	66
4751-4960	210	163	78	.34	1023	603	371	98
4961-5000	40	32	80	.36	2037	1313	771	42
5001-5250	250	94	38	.34	1735	735	433	69
5251-5500	250	136	54	.35	1466	899	540	122
5501-5750	250	82	33	.31	595	290	186	24
5751-6000	250	142	57	.29	382	162	108	23
6001-6100	100	4	4	.29	234	145	97	.58
6101-6250	250	49	20	.33	690	489	305	24
6251-6500	250	135	54	.33	903	551	341	74
6501-6750	250	158	63	.32	725	321	205	51
6751-70-0	250	86	34	.31	466	243	158	21
7001-7250	250	138	55	.29	278	157	105	22
7251-7500	250	33	13	.28	374	107	73	3.5
7501-7730	230	94	41	.27	208	63	45	5.9
7731-8000	270	128	47	.26	87	48	35	6.1
8001-8250	250	66	26	.22	24	14	11	.92
8251-8500	250	110	44	.21	80	13	10	1.4
8501-8750	250	30	12	.18	69	5	3.7	.15
8751-9000	250	122	49	.19	13	6	4.6	.73
9001-9250	250	112	45	.21	75	11	8.7	1.2
9251-9500	250	101	40	.27	262	65	46	6.6
9501-9750	250	209	84	.21	85	12	9.3	2.5
9751-10050	300	204	68	.16	8	2	1.8	.41

A-28

G. FIGURES

EAST MESA LOG HORIZ PERM VS POP

A-30

H
R
I
Z

P
L
O
G

B
A
S
E

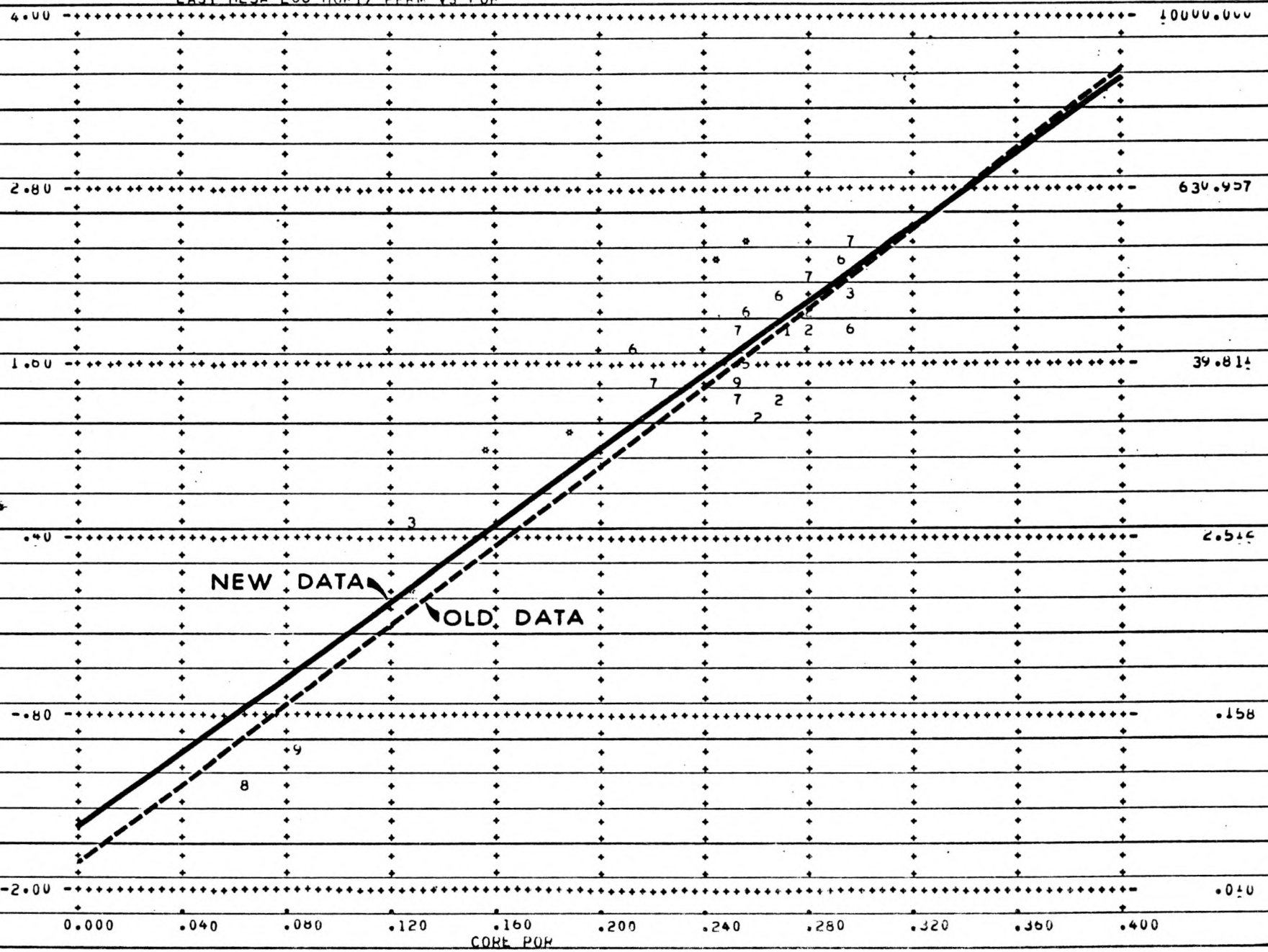

NEW DATA

OLD DATA

Z AXIS

1 2 3 4 5 6 7 8 9 *
 5593.000 5598.100 5603.200 5608.300 5613.400 5618.500 5623.600 5628.700 5633.800 5638.900 5644.000
 CORE POP
 DEPTH
 intercomp
 Figure 1

EAST MESA LOG HORIZ VS VERT PERM

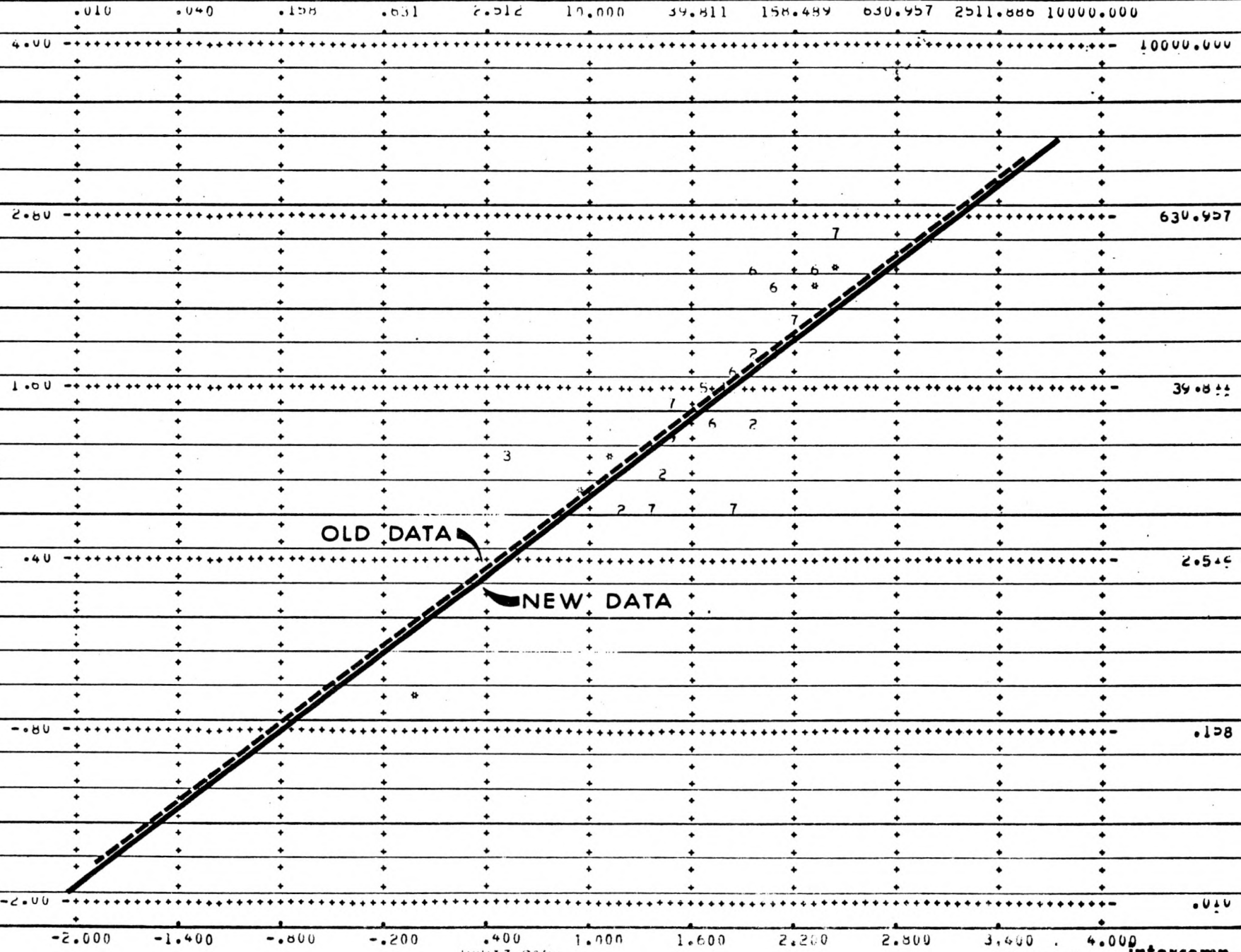

A-31

OLD DATA

NEW DATA

HORIZ PERM
LOG BASE 10

Figure 2

Intercomp

Z AXIS

1 2 3 4 5 6 7 8 9 *

REP GEO 38-30 ODFN VS PHI 5200-6500

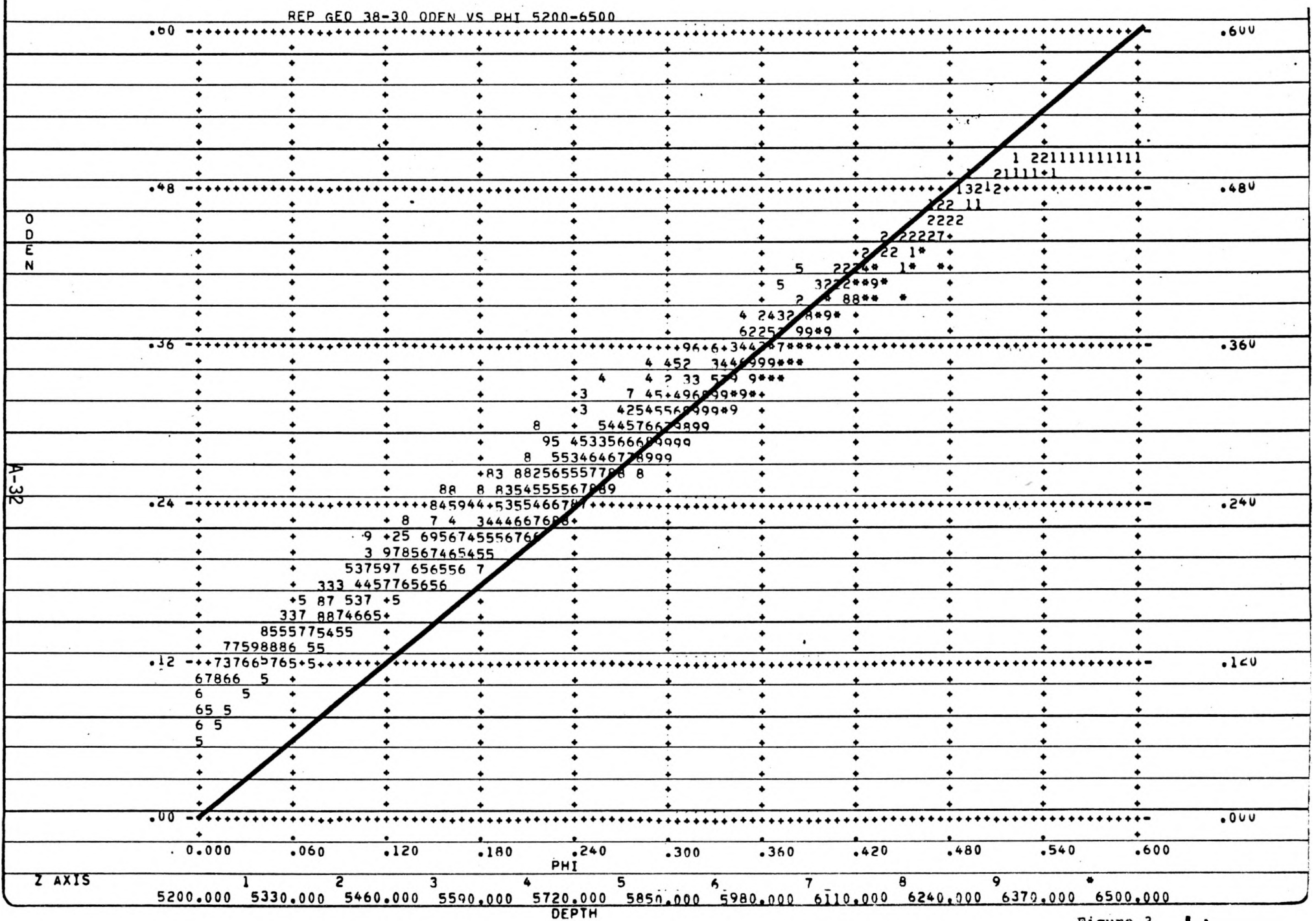
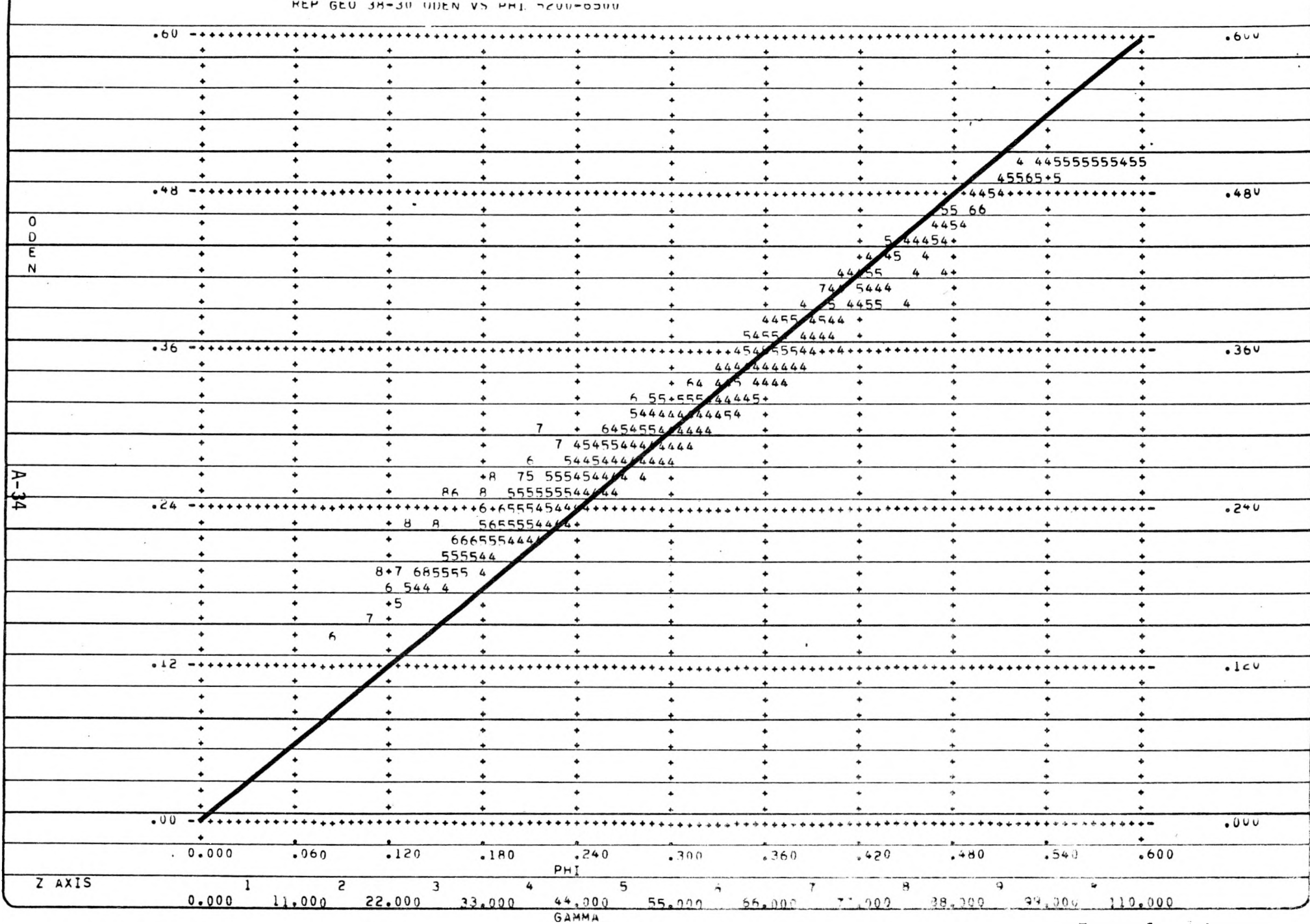

Figure 3 Intercomp



O
D
F
Z

A-34

Figure 5 intercomp

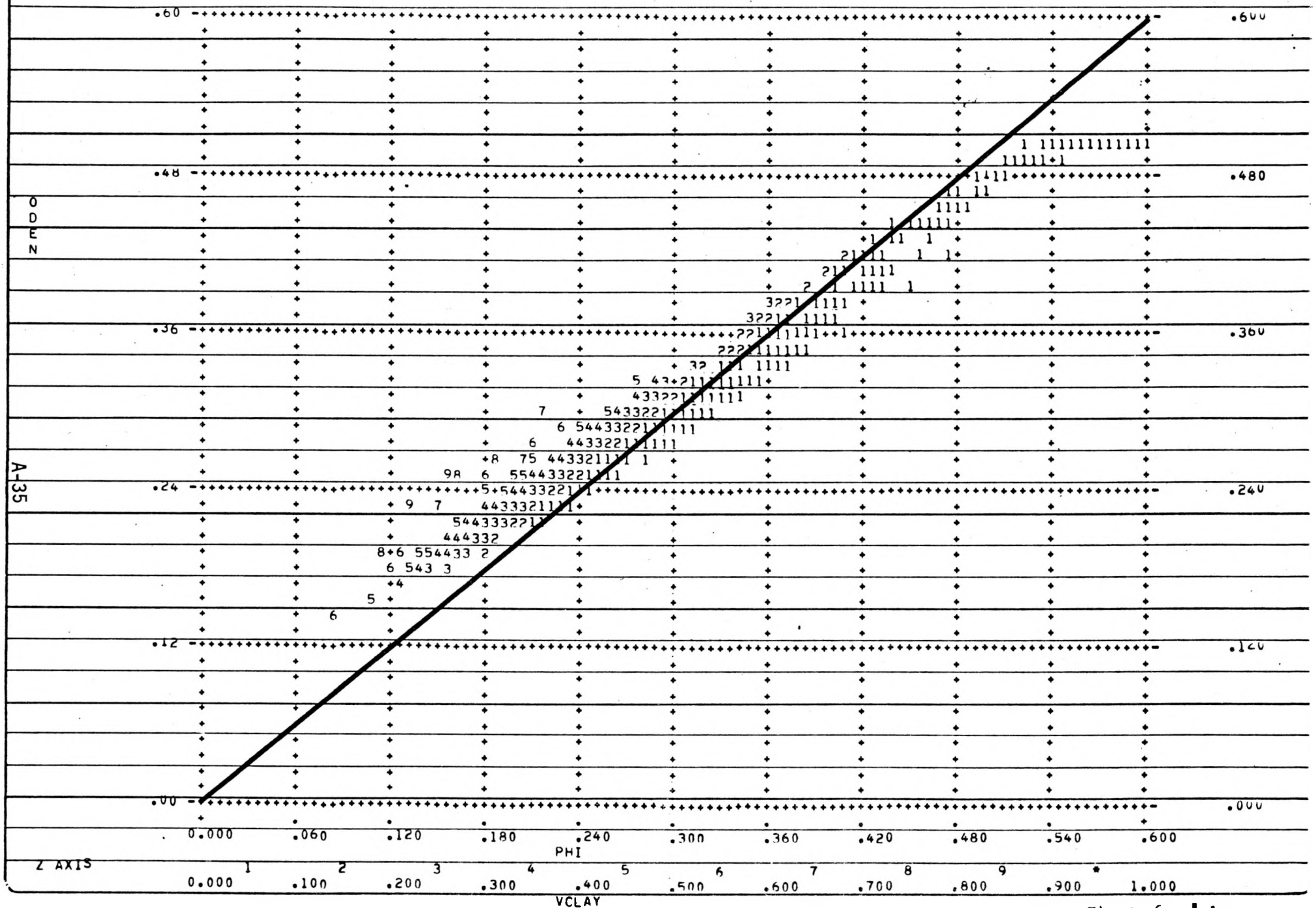

Figure 6 intercomp

REP GEO 38-30 CNL POR VS FDC POR VS GAMMA 5200-6500

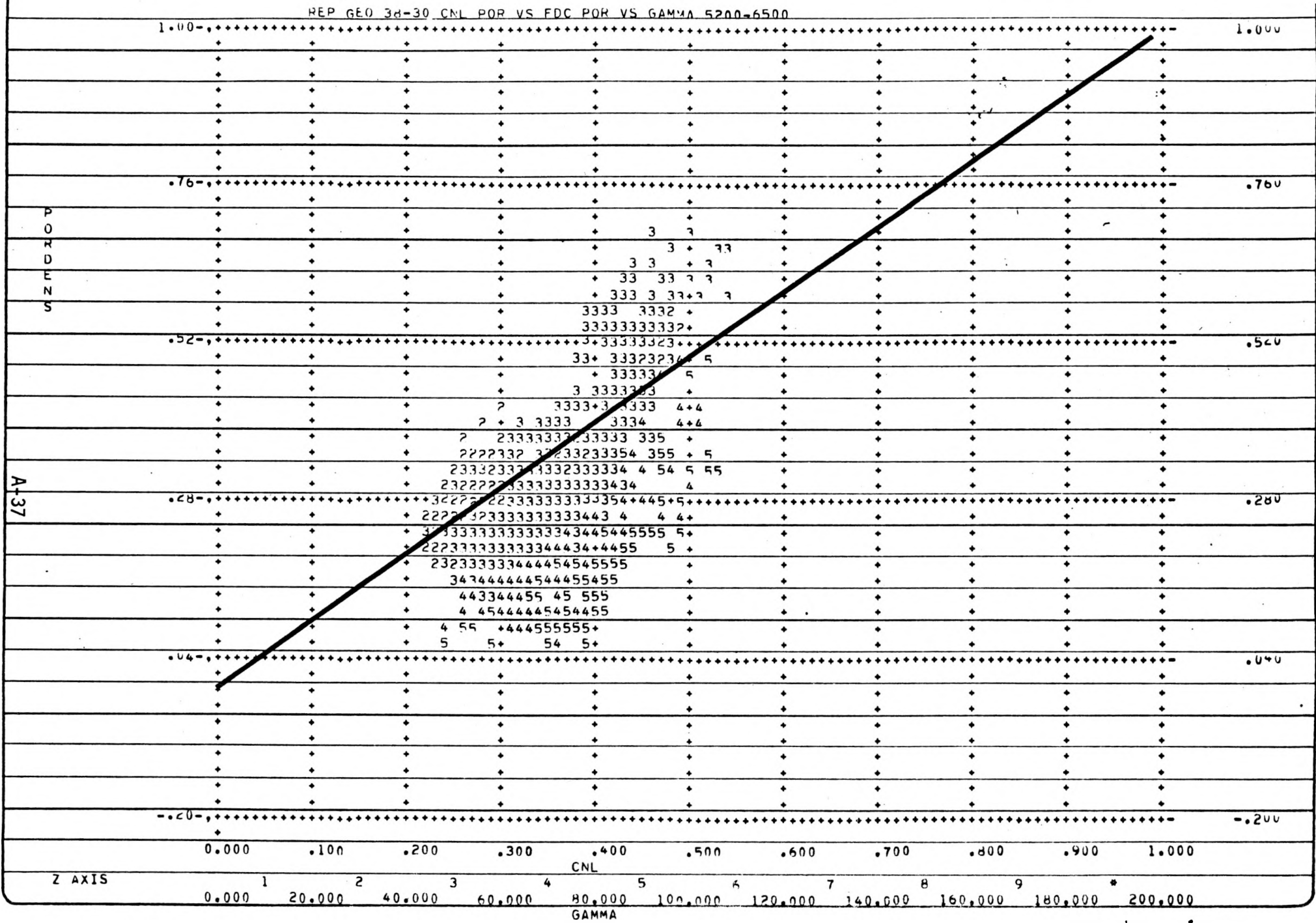

Figure 8 Intercomp

REP GEO 38-30 CNL POR VS FDC POR VS CALIPER 5200-6500

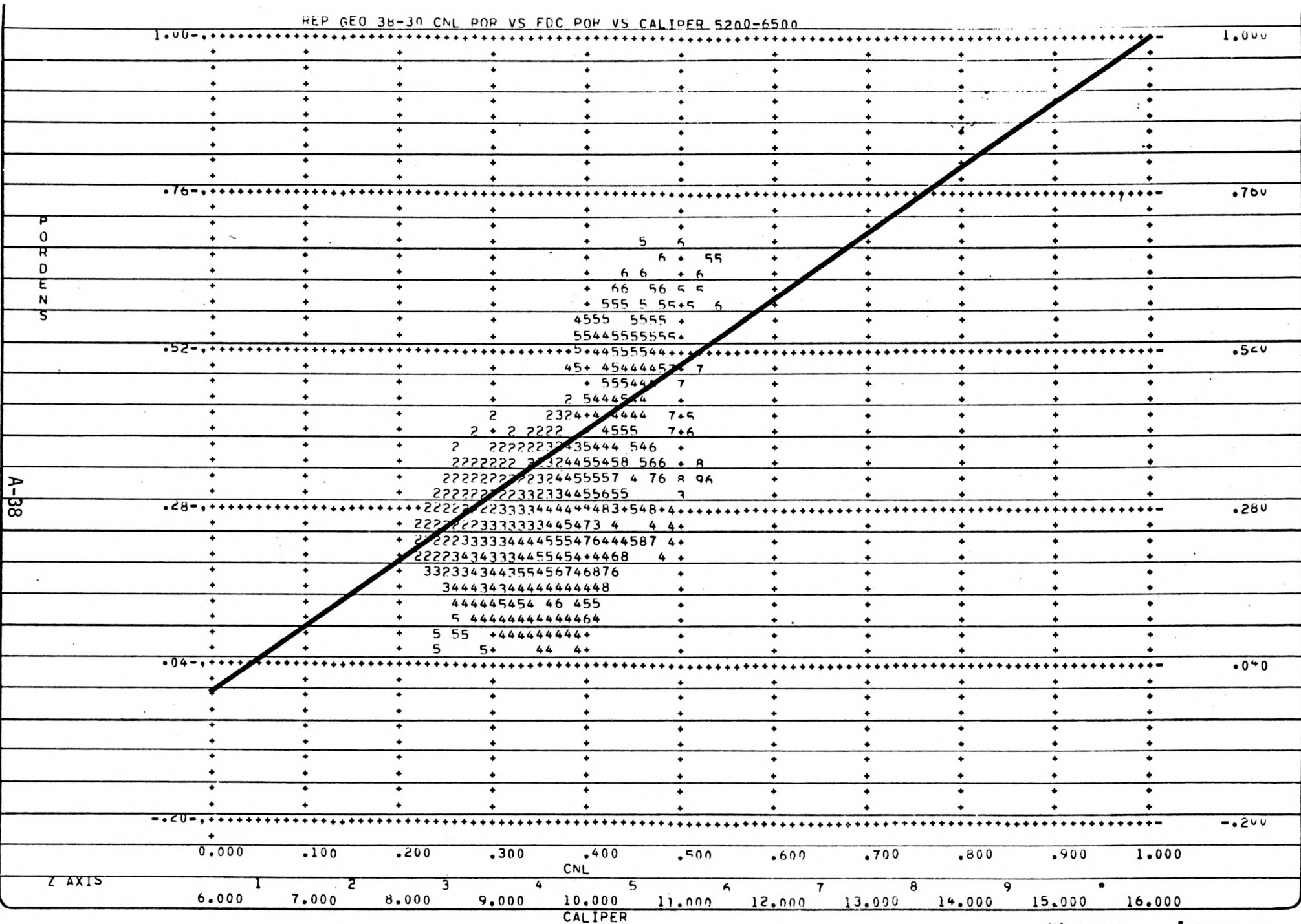

Figure 9 Intercomp

REP GEO 3H-30 GAMMA VS VCLAY 5200.6500.

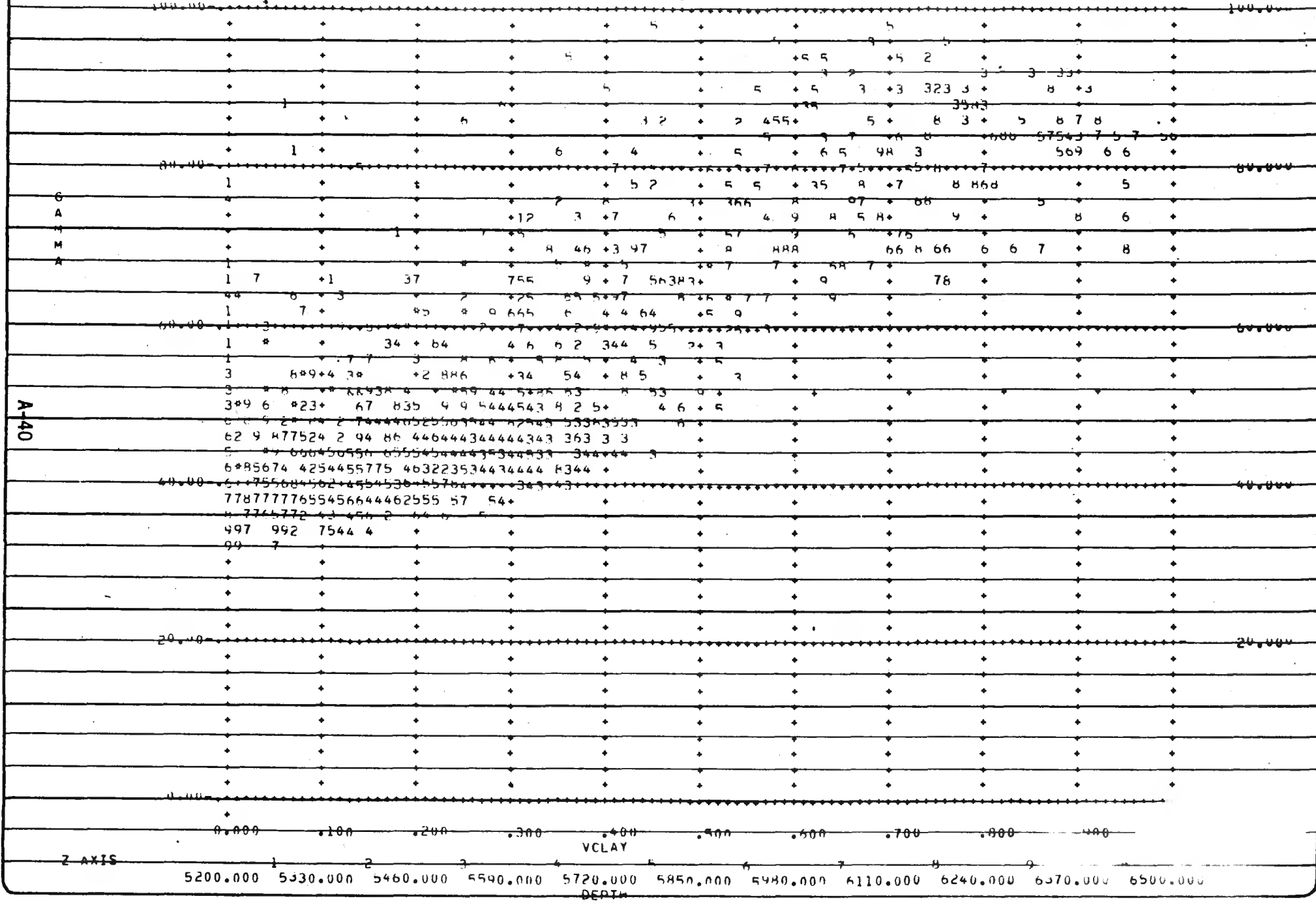

Figure 11 intercomp

REP GEO 38-30 SP VS VCLAY 5200-6500

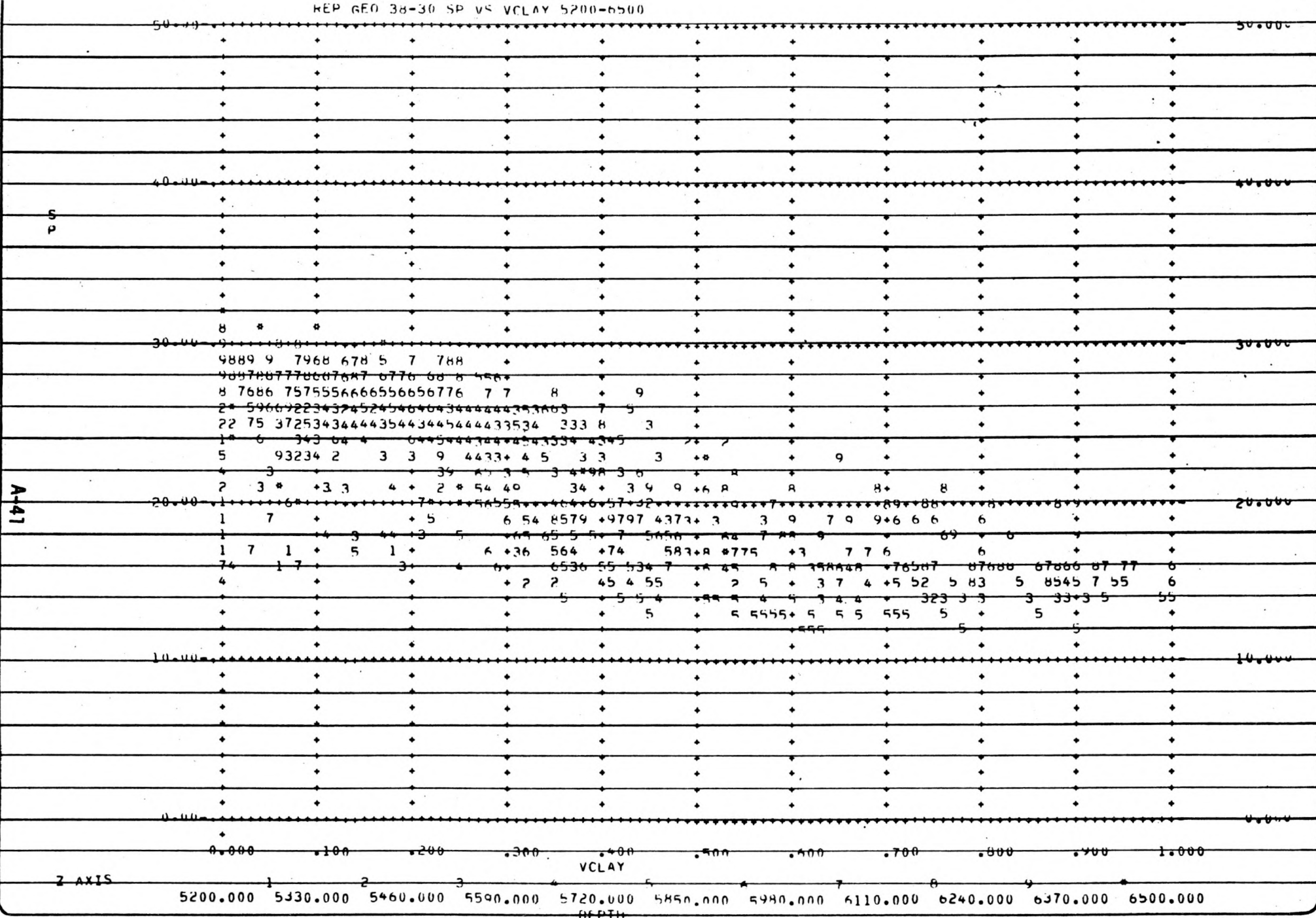

Figure 12 Intercomp

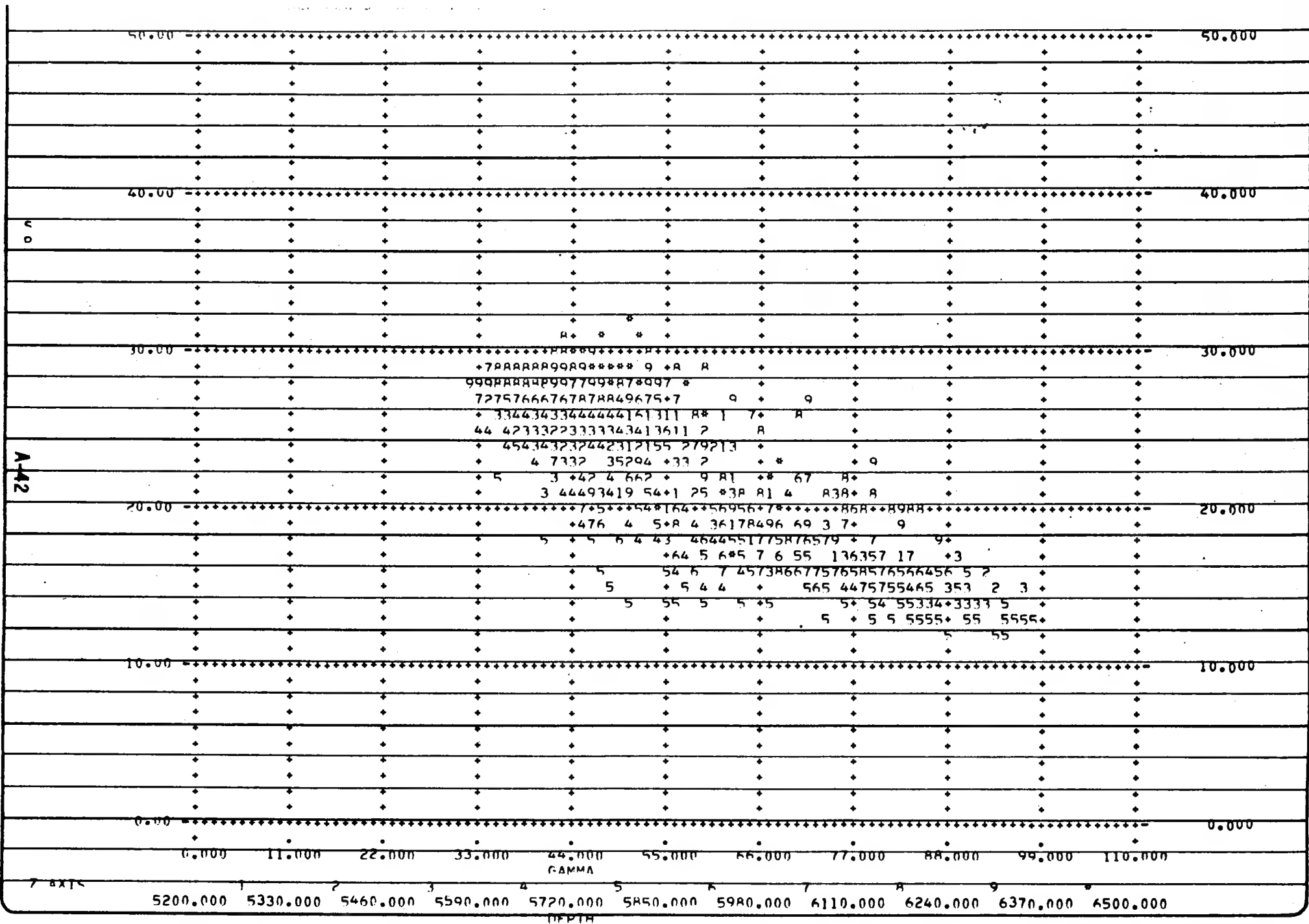

Figure 13 Intercomp

MAX VALUE = 98.120 MIN VALUE = 41.396

100.000 90.000 80.000 70.000 60.000 50.000 40.000 30.000 20.000 10.000 0.000

20.00 --

16.00 --

12.00 --

8.00 --

4.00 --

0.000 =

100.000 90.000 80.000 70.000 60.000 50.000 40.000 30.000 20.000 10.000 0.000

A43

P
E
R
C
E
N
T
O
F
S
A
M
P
L
E

REV 6-80 20-30 (GAMMA VS VCLAY SPAN, 0.500)

Figure 14 Intercomp

REP GEO 3H-30 PHI VS DEPTH 5200-8900 SANDS ONLY

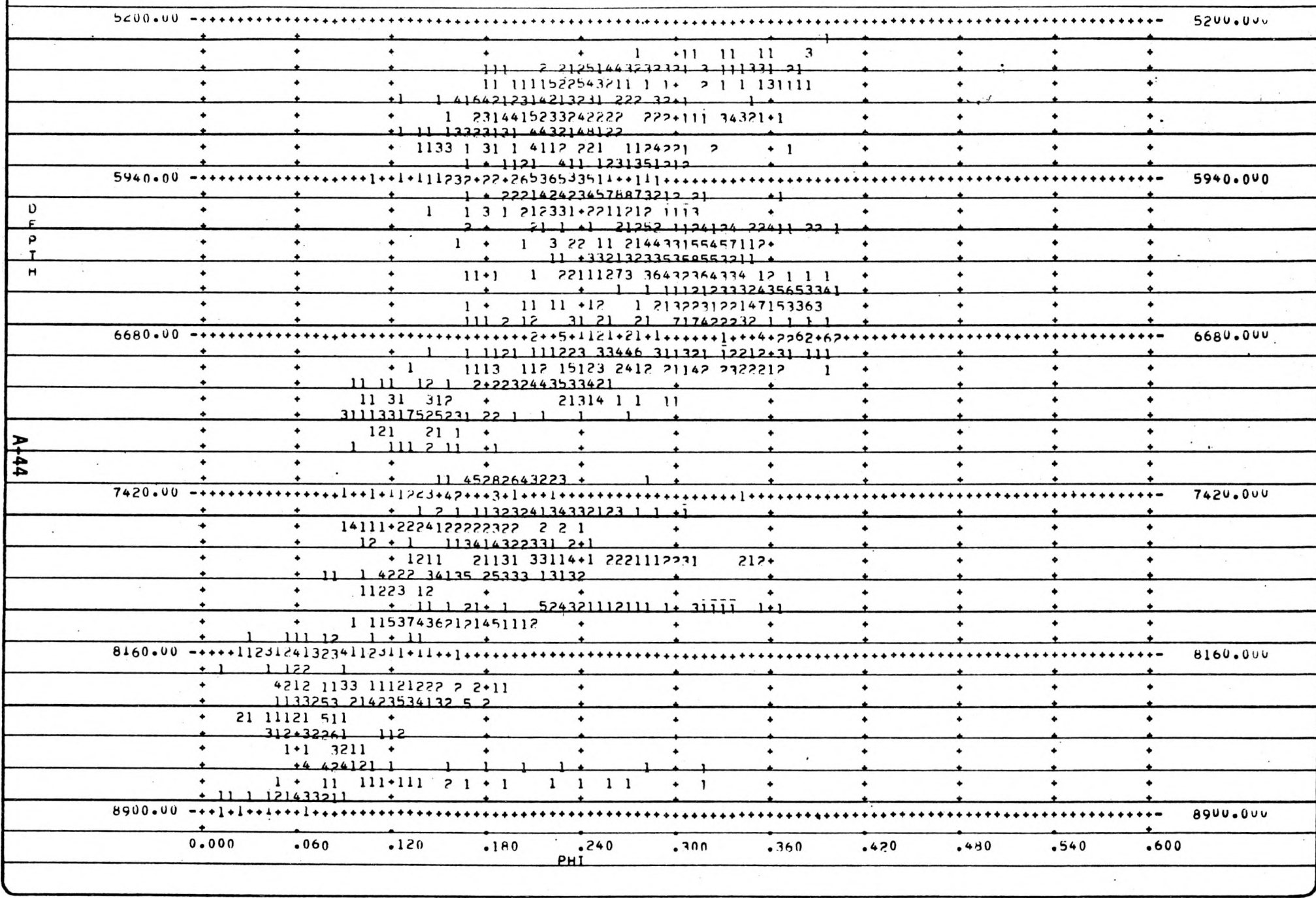
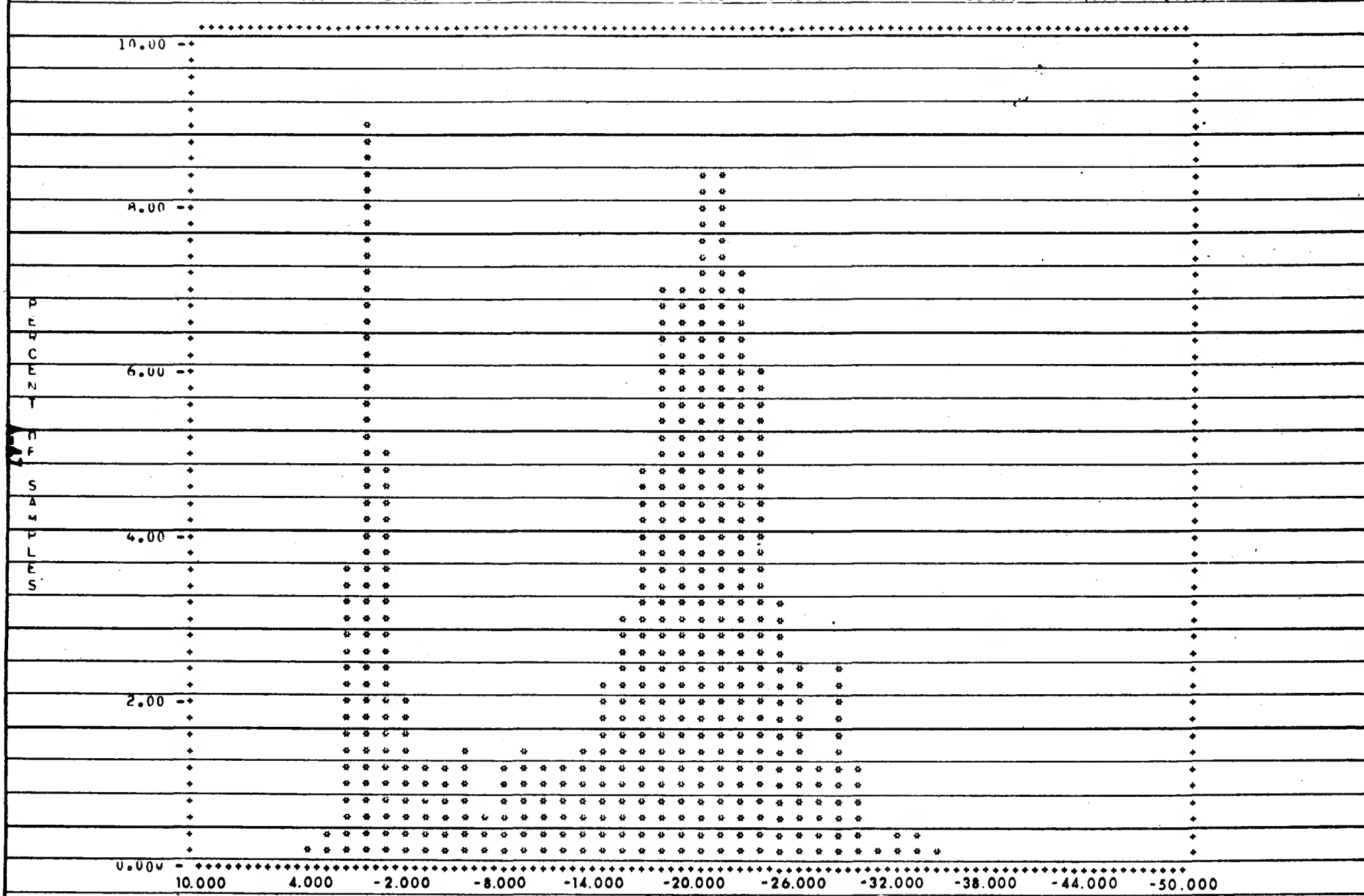

Figure 15 Intercomp

MAX VALUE = 10.000 4.000 -2.000 -8.000 -14.000 -20.000 -26.000 -32.000 -38.000 -44.000 -50.000
 MIN VALUE = -30.000



MAGMA SHARP SP VS ILD 4620-6000

Figure 18 Intercomp

APPENDIX B

DRILLING PROGRAMS

EAST MESA

IMPERIAL VALLEY

CALIFORNIA

Prepared for

TRW INC.

Prepared By

DRESSER

Oilfield Products Division



Oilfield Products Division

DRESSER INDUSTRIES, INC.

P.O. BOX 6504 HOUSTON, TEXAS 77005 (713) 781-5900 TWX 910-881-2570

July 28, 1976

TRW, Systems Group
One Space Park
Redondo Beach, California 90278

Attention: Mr. Russell Pearson

Dear Sirs:

Enclosed is the drilling prognosis for the three geothermal wells to be drilled by the Bureau of Reclamation at their East Mesa site, Imperial Valley, Imperial County, California

We hope that Dresser's involvement in this project continues from this point forward by the use of the products and services incorporated in the programs. These include:

1. Dresser Magcobar drilling fluids systems.
2. Dresser Security drilling bits.
3. Dresser Atlas geophysical logging.
4. Dresser Guiberson "Kleen Screen."
5. Well site supervision by the Dresser Magcobar Drilling Engineering Section.
6. Dresser Swaco solids separation equipment, rotating head, and choke.

The utilization of all Dresser products and services affords a big plus for our operators. At the start of the prospect, a project manager would be assigned as a coordinator of Dresser services and liaison between Dresser, TRW, and the Bureau of Reclamation. TRW and the Bureau of Reclamation would then look to him to coordinate all Dresser related operations for these proposed wells. Drilling efficiency is directly related to an inter-marriage between bits, mud, mechanical equipment, and hydraulics. Using several different service companies would not bring all these factors together and make them work for the operator. Only when they are all placed under direct supervision of one technical manager is this possible. Dresser is the only oilfield service company with many years of experience in total project management.

The recommended intermediate casing depths are approximate depths. Actual setting depths should be just above the production and are to be determined from correlation with other logs in the area.

**MAGCOBAR DRILLING MUDS SWACO DETECTION & CONTROL EQUIPMENT
SECURITY ROCK BITS & DRILLING TOOLS GUIBERSON PACKERS, PUMPS & OIL TOOLS**

The pricing schedules are broken down into three basic categories:

1. All three wells as proposed (one straight; two directional).
2. All three wells as straight holes.
3. Average costs per interval.

The contingency should take into account price escalations between the present and the time of actual drilling.

Sincerely,

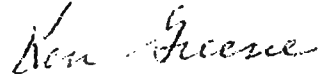

Ken Greene, Manager
Drilling Engineering Section
Magcobar Division, Dresser

KG/nr

LIST OF APPENDIXES

- I. DIRECTIONAL DRILLING
- II. DRESSER MAGCOBAR DRILLING FLUID AND HYDRAULICS
- III. DRESSER ATLAS BOREHOLE GEOPHYSICAL LOGGING
- IV. DAYS vs. DEPTH
- V. DRESSER SECURITY ROCK BITS
- VI. CASING HEADS, BLOWOUT PREVENTERS
- VII. MAP OF AREA
- VIII. DRESSER GUIBERSON OPEN HOLE GRAVEL PACK
- IX. RIG SPECIFICATIONS

DRILLING GEOTHERMAL PRODUCTION WELL
AND TWO PRODUCTION/INJECTION WELLS
EAST MESA IMPERIAL VALLEY, CALIFORNIA

F O R E W O R D

Work under these specifications consists of the drilling of one geothermal producing well and two geothermal producing/injecting wells to a T.V.D. of 6500 feet.

The work is situated in the Mesa anomaly and in the vicinity of the Bureau of Reclamation's wells, Mesa 6-1 and Mesa 6-2, located approximately ten miles east of Holtville, California. The producing well and one of the producing/injecting wells are to be directionally drilled, the former having 2000 feet of throw and the latter 4000 feet.

For these three geothermal wells, the contractor will drill 26 inch holes to 60 feet, and furnish and set 20 inch casing, cemented to the surface. The contractor will drill 17½ inch holes to 2000 feet, and furnish and set 13-3/8 inch casing, cemented to the surface. The contractor will also drill 12¼ inch holes to a depth above the producing horizon, and furnish and set 9-5/8 inch casing. This depth should be determined by correlation with other logs in the area. Cementing of these strings shall be in accordance with section 2.2.9. The contractor will then drill 8½ inch holes

to a T.V.D. of 6500 feet, run Howard Smith screen with Burns liner hanger, and gravel pack the entire open hole in accordance with 2.2.13 using Guiberson "Kleen Screen" as the packing medium. At the completion of each interval of hole, the contractor will furnish borehole geophysical logging, Dresser Atlas, or equal as described in 2.2.10. As drilling progresses, drill stem tests and coring shall be performed at depths as directed by the contracting officer. Detailed drilling procedures are listed in section 1.2.2 (Description of the Work).

The contractor will be required to furnish all equipment, materials, and services (section 1.2.7) except a mud cooling tower and guard valves for the geothermal wells, which will be furnished by the Government. (section 1.2.8)

COST SCHEDULE I (3 Wells, 2 Directional)

Item No.	Description	Cost/Well	Total
1.	Site Preparation		TRW
2.	Cellar Construction		TRW
3.	Mobilization and Demobilization	One Time Charge	15,000.
4.	Move (Site to Site)	5,000.	10,000.
5.	Casing (2.2.7)		
	Conductor (20 inch)	1,806.	5,418.
	Surface (13-3/8 inch)	35,480.	106,440.
	Intermediate (9-5/8 inch)		
	straight hole	47,432.	
	24° angle hole	54,982.	
	48° angle hole	62,672.	165,036.
	Centralizers, Shoe, Collar		
	20 inch	1,600.	4,800.
	13-3/8 inch	2,450.	7,350.
	9-5/8 inch	3,990.	11,970.
	Crews	6,500.	19,500.
6.	Drilling Fluid/Solids Separation Equipment (Appendix II)		
	straight hole	19800/3850	
	24° angle hole	26000/4725	
	48° angle hole	31000/5600	90,975.
7.	Drilling Bit Costs (Appendix V)		
	straight hole	8,749.	
	24° angle hole	9,505.	
	48° angle hole	11,077.	29,331.
8.	Directional Drilling Costs		
	24° angle hole	27,000.	
	48° angle hole	32,000.	59,000.
9.	Mud Logging Services		
	straight hole	6,500.	
	24° angle hole	8,125.	
	48° angle hole	9,750.	24,375.

Cost Schedule I (cont'd.)

Item No.	Description	Cost/Well	Total
10.	Borehole Geophysical Logging (Appendix III)		
	straight hole	15,715.	
	24 ⁰ angle hole	16,459.	
	48 ⁰ angle hole	20,684.	52,858.
11.	Casing Heads and Spools		
	Producer	10,991.	
	Injectors (2)	6,820. ea.	24,631.
12.	Supervisory Costs		
	straight hole	6,050.	
	24 ⁰ angle hole	7,425.	
	48 ⁰ angle hole	8,800.	22,275.
13.	Day Work (Rig)		
	straight hole	88,000.	
	24 ⁰ angle hole	108,000.	
	48 ⁰ angle hole	128,000.	324,000.
14.	Cementing Costs	39,300.	117,900.
15.	Furnish & Set Packer Assembly and Gravel Pack (Appendix IX)		
	straight hole	29,350.	
	24 ⁰ angle hole	31,500.	
	48 ⁰ angle hole	36,200.	97,050.
16.	Swaco Rotating Head	1,485.	4,455.
	Swaco Super Choke	1,296.	<u>3,838.</u>
	Total Costs (3 wells)		\$1,196,307.
	Contingency		119,631.
	Total		1,315,938.
	Average Cost/Well		438,646.

Cost Schedule I (cont'd.)

COST RECAP*

Straight Hole	\$ 368,755.
24° Angle Hole	439,700.
48° Angle Hole	507,505.

* includes contingency

COST SCHEDULE II (3 Wells, All Straight)

Item No.	Description	Cost/Well	Total
1.	Site Preparation		TRW
2.	Cellar Construction		TRW
3.	Mobilization and Demobilization One Time Charge		15,000.
4.	Move (Site to Site)	5,000.	10,000.
5.	Casing (2.2.7)		
	Conductor (20 inch)	1,806.	5,418.
	Surface (13-3/8 inch)	35,480.	106,440.
	Intermediate (9-5/8 inch)	47,432.	142,296.
	Centralizers, Shoe, Collars		
	Conductor (20 inch)	1,600.	4,800.
	Surface (13-3/8 inch)	2,450.	7,350.
	Intermediate (9-5/8 inch)	10,340.	31,020.
6.	Drilling Fluid/Solids Separation (Appendix II)	19800/3850	70,950.
7.	Drilling Bit Costs	8,749.	26,247.
8.	Mud Logging Costs	6,500.	19,500.
9.	Borehole Geophysical Logging (Appendix III)	15,715.	47,145.
10.	Casing Heads and Spools		
	Producer	10,991.	
	Injectors (2)	6,820. ea.	24,631.
11.	Supervisory Costs	6,050.	18,150.
12.	Day Work (Rig)	88,000.	264,000.
13.	Cementing Costs	39,300.	117,900.

Cost Schedule II (cont'd.)

Item No.	Description	Cost/Well	Total
14.	Furnish and Set Packer and Gravel Pack (Appendix IX)	29,350.	88,050.
15.	Swaco Rotating Head	1,210.	3,630.
	Swaco Super Choke	1,056.	<u>3,168.</u>
		Total Costs	\$1,005,695.
		Contingency	100,570.
		Total	\$1,106,265.
		Average Cost/Well	368,755.

COST SCHEDULE III

3 Wells - 2 Directional

Average Cost per Interval - All Wells

Item No.	Description	Average Cost/Well	Total
1.	Site Preparation		TRW
2.	Construct Cellar		TRW
3.	Mobilization and Demobilization		15,000.
4.	Move - Site to Site	5,000.	10,000.
5.	Drill 26 inch Hole Set 20" Conductor Drill 17½ inch Surface Hole Set 13-3/8 inch casing - Cement	62,689.	188,067.
6.	Drill 12½ inch Hole to TVD of 5500+ feet - Set 9-5/8 inch casing - Cement	222,073.	666,240.
7.	Drill 8½ inch Hole to TVD of 6500 feet - Gravel Pack Open Hole	97,463.	292,390.
8.	Furnish Casing Heads and Spools	8,210.	24,630.
			<u>\$1,196,307.</u>

SECTION 1.2 . . .

1.2.1 The Requirement

The requirement includes drilling three geothermal wells as described herein, one as a producer and two as producer/injector wells. The wells are located near Holtville, California in Section 1, T16S-R16E, Section 6, T16S-R17E, and Section 9, T16S-R17E.

1.2.2 Description of the Work

General --- Drilling shall be performed by the rotary drilling method for all three wells to a true vertical depth of 6500 feet. A general description of the drilling process is as follows:

1. Move in and rig up.
2. Drill 17½ inch hole to 60 feet. Open hole to 26 inches.
3. Circulate hole clean. Make wiper trip. Pull out of the hole.
4. Run 20 inch casing and cement per cementing schedule. (2.2.9)
5. Cut 20 inch casing and weld on 20 inch 2000 psi series 600 flange and nipple up 20 inch Hydril. Rig up mud logging unit.
6. Drill out plug and shoe and cement with 17½ inch bit and drill to 2000 feet.
7. Circulate hole clean. Make wiper trip into 20 inch casing. Go back to bottom and circulate bottoms up. Pull out of hole and run suite of logs as per logging schedule. (2.2.10) Go in hole. Condition to run 13-3/8 inch casing. Pull out of hole running multishot.
8. Run 13-3/8 inch casing with float shoe and float collar. Place float collar on top of first (1st) joint. Use thread lock on shoe and collar. Strap shoe and collar. Cement using two plug method as per cement schedule. (2.2.9)

9. Nipple down 20 inch hydril. Cut 20 inch and 13-3/8 inch casing off. Install 13-3/8 inch weld on x 12 inch 3000 W.P. flange. Test to 1000 psi. Nipple up 12 inch B.O.P.'s. Install mud cooling tower. Install Swaco rotating head and super choke.
10. Pick up test plug. Run in and set in casing head. Test rams to 3000 psi-Hydril to 1500 psi. Lay down test plug.
11. Pick up bottom hole assembly. Go in hole. Drill float collar. Test 13-3/8 inch casing to 1700 psi. Drill float shoe.
12. Drill 12¼ inch hole to 5500 feet. Use stabilizers above second (2nd), fourth (4th), sixth (6th), eighth (8th), and tenth (10th) drill collars. If hole is directional, use B.H.A. designed by directional driller at well site.
13. Circulate hole clean; make wiper trip into surface casing; go back to bottom. Circulate bottoms up. Pull out of hole to log. Run sequence of logs per logging schedule. (2.2.10)
14. Go in hole after logging. Circulate and condition hole. Make wiper trip. Go in hole. Circulate bottoms up. Pull out of hole to run 9-5/8 inch casing.
15. Run 9-5/8 inch casing as per casing schedule; cement as per cementing schedule. (2.2.9) Hang 9-5/8 inch in 13-3/8 inch surface casing with 200 foot overlap.
16. Go in hole with 12¼ inch bit and dress off top of liner. Circulate hole clean. Pull out of hole. Pick up 6 inch bottom hole assembly. Go in hole. Clean out 9-5/8 inch casing. Test 9-5/8 inch casing to 800 psi. Pull out of hole.
17. Pick up new bit. Go in hole. Drill 8½ inch hole to T.V.D. of 6500 feet. Circulate hole clean; make wiper trip. Circulate bottoms up. Pull out of hole to log.

18. Log as per logging schedule. (2.2.10)
19. Go in hole. Condition hole to run 7 inch gravel pack screen.
20. Pull out of hole. Pick up gravel packing screen assembly. Go in hole and hang 7 inch screen in 9-5/8 inch casing. Gravel pack as per Appendix IX.
21. Pull out of hole. Nipple down B.O.P.'s. Install guard valves. Go in hole. Displace mud with brine water. Test well.

1.2.3 Commencement, Prosecution, and Completion of Work

a. Completion Period.--Based upon all available records and calculated average penetration rates in the area, the following are estimated days for drilling of the wells: (Appendix IV)

(1) Straight Hole	-	22 days
(2) 24 ⁰ Hole	-	27 days
(3) 48 ⁰ Hole	-	32 days

b. Prosecution and Commencement.--As to the total days allowed and starting dates, these should be determined by the Government.

1.2.4 through 1.2.6 N/A for Dresser.

NOTE: DRESSER, AS A SUBCONTRACTOR TO TRW, CANNOT DETERMINE MATERIALS THAT WILL BE FURNISHED BY THE CONTRACTOR OR THE GOVERNMENT ON THIS PARTICULAR PROJECT. SECTIONS 1.2.7 and 1.2.8 INCORPORATE THE GOVERNMENT'S WORDING AND MAY OR MAY NOT APPLY HERE.

1.2.7 Materials to be Furnished by the Contractor

a. General.--The contractor shall furnish all materials required for completion of the work except the materials listed in Paragraph 1.2.8. (Equipment, Materials, and Services Furnished by the Government).

When a separate item, which includes the furnishing of any material, is provided in the schedule, the cost of furnishing, hauling, storing, and handling shall be included in the price bid for that item. When a separate item is not provided in the schedule for furnishing any material required to be furnished by the contractor, the cost of furnishing, hauling, storing, and handling shall be included in the price bid for the work for which the material is required.

Materials furnished by the contractor shall be of the type and quality described in these specifications. The contractor shall make diligent effort to procure the specified materials from any and all sources, but where because of Government priorities or other causes, materials required by the specifications become unavailable, substitute materials may be used:

Provided, That no substitute materials shall be used without prior written approval of the contracting officer, said written approval to state the amount of the adjustment, if any, to be made in favor of the Government.

The contracting officer's determination as to whether substitution shall be permitted and as to what substitute materials may be used shall be final and conclusive. If the substitute materials approved are of less value to the Government or involve less cost to the contractor than the materials specified, an adjustment shall be made in favor of the Government, and where the amount involved or the importance of the substitution warrants, an order for changes will be issued, otherwise the adjustment will be handled by deduction

from payments to the contractor on the basis of prices stated in the written approval. No payments in excess of prices bid in the schedule will be made because of substitution of one material for another or because of the use of one alternate material in place of another.

b. Inspection of materials.--Materials and equipment furnished by the contractor which will become a part of the completed construction work, shall be subject to inspection in accordance with Clause No. 5 of the General Provisions at any one or more of the following locations as determined by the contracting officer: at the place of production of manufacture, at the shipping point, or at the site of the work. To allow sufficient time to provide for inspection, the contractor shall submit to the contracting officer, at the time of issuance, copies in triplicate of purchase orders, including drawings and other pertinent information, covering materials and equipment on which inspection will be made as advised by the contracting officer, or shall submit other evidence in the event such purchase orders are issued verbally or by letter.

The inspection of materials and equipment at any of the locations specified above or the waiving of the inspection thereof shall not be construed as being conclusive as to whether the materials and equipment conform to the contract requirements, nor shall the contractor be relieved thereby of the responsibility for furnishing materials and equipment meeting the requirements of these specifications. Acceptance of all materials and equipment will be made only at the site of the work.

1.2.8 Equipment, Materials, and Services Furnished by the Government

The Government will furnish the following equipment, materials, and services:

a. Mud cooling tower with blower will be made available to the contractor for his use. The Government will deliver the tower to the contractor at the drill site. The tower has been used under a previous contract. The contractor shall accept the tower as his own and shall erect, make all connections, and perform all maintenance required to operate the cooling tower. Upon completion of the work, the contractor shall clean and dismantle the tower and deliver it to the Government at the site of the work in good condition and as received, usual wear excepted.

b. Access roads and maintenance of access roads.

c. Mud logging, including monitoring and recording mud flow line temperatures in and out of the well. Recording drilling time log and washing, preparing, and packing samples of drill cuttings.

SECTION 2.2 . . . DRILLING WELLS

2.2.1 Drilling Wells, General

The purpose of the work required under these specifications is to drill one geothermal producing well and two geothermal producing/injecting wells to a true vertical depth (T.V.D.) of 6500 feet. The producer well and one of the producer/injector wells will be directionally drilled. The producer will have 2000 feet of horizontal throw and the one producer/injector will have 4000 feet of horizontal throw. Angles and build-up rates are listed in Appendix I.

For these three geothermal wells, the contractor will drill 26 inch holes to 60 feet, and furnish and set 20 inch casing, cemented to the surface. The contractor will drill 17½ inch holes to 2000 feet, and furnish and set 13-3/8 inch casing, cemented to the surface. The contractor will also drill 12¼ inch holes to a depth above the producing horizon, and furnish and set 9-5/8 inch casing. This depth should be determined by correlation with other logs in the area. Cementing of these strings shall be in accordance with section 2.2.9. The contractor will then drill 8½ inch holes to a T.V.D. of 6500 feet, run Howard Smith screen with Burns liner hanger, and gravel pack the entire open hole in accordance with 2.2.13 using Guiberson "Kleen Screen" as the packing medium. At the completion of each interval of hole, the contractor will furnish borehole geophysical logging, Dresser Atlas, or equal as described in 2.2.10. As drilling progresses, drill stem tests and

coring shall be performed at depths as directed by the contracting officer. Detailed drilling procedures are listed in section 1.2.2. (Description of the Work).

2.2.2 Mobilization and Demobilization

Mobilization and demobilization for drilling includes moving onto the site, assembling into the working condition, disassembling, and removing from the site all equipment and supplies necessary to perform the required drilling operations.

2.2.3 Moving from Well Site to Well Site

This item includes the cost of moving the drill rig and all equipment, materials, and tools to each drill site. Setting up of all equipment is outlined in 1.2.2. (Description of the Work)

2.2.4 Drilling Methods and Practices

The contractor should drill a 17½ inch hole for the 20 inch conductor casing, and open the hole to 26 inches. The contractor should also drill a 17½ inch hole for the surface casing, a 12¼ inch hole for the intermediate casing, and an 8½ inch hole to total depth.

Because of the unconsolidated nature of the sands to be penetrated by the rock bit, good hydraulics and annular flow patterns should be maintained as described in Appendix II (Mud and Hydraulics). Observation of the recommended pumping rates will afford optimum hydraulics and reduce the amount of

hole erosion. The reduction in hole erosion affords less annular mud weight, which aggravates lost circulation problems and provides for better cementing practices and less cement requirements.

Two of the wells will be directionally drilled as described in Appendix I. The straight hole should be maintained as the Bureau of Reclamations requests.

The drilling mud is designed with a high temperature viscosifier (Thermogel) to reduce temperature flocculation, and is of suitable quality to provide good hole conditions and remove all drill solids from the hole. (Appendix II Mud and Hydraulics) A lubricant (Magcolube) is recommended on the directional wells to reduce torque and drag and generally lubricate the hole.

2.2.5 Responsibility for Loss of or Damage to the Equipment or the Hole

N/A for Dresser.

2.2.6 Conductor Casing

The conductor casing should be 20 inches to be set in a 26 inch hole at 60 feet depth. Actual materials recommended are described in 2.2.7 (Casing).

2.2.7 Casing

a. Surface casing shall be cemented to the surface and 9-5/8 inch shall be cemented as described in cementing procedures (2.2.9). All casing should be equipped with quick release thread protectors and high temperature thread compound used while making up joints.

b. Conductor Casing (All Three Wells)

Depth	O.D.	Weight #/ft.	Grade	Range	Thread
0-60	20"	94	K-55	3	Buttress

c. Surface Casing (All Three Wells)

Depth	O.D.	Weight #/ft.	Grade	Range	Thread
0-2000	13-3/8	61	K-55	3	Buttress

d. 9-5/8" Casing - Straight Hole

Depth	O.D.	Weight #/ft.	Grade	Range	Thread
1800-2500	9-5/8	36	K-55	3	Buttress
2500-3500	9-5/8	40	K-55	3	Buttress
3500-4500	9-5/8	40	N-80	3	Buttress
4500-5500	9-5/8	40	S-95	3	Buttress

e. 9-5/8" Casing - Low Angle Hole (24⁰)

Depth	O.D.	Weight #/ft.	Grade	Range	Thread
1800-2500	9-5/8	36	K-55	3	Buttress
2500-3500	9-5/8	40	K-55	3	Buttress
3500-4500	9-5/8	40	N-80	3	Buttress
4500-6000*	9-5/8	40	S-95	3	Buttress

f. 9-5/8" Casing - High Angle Hole (48⁰)

Depth	O.D.	Weight @/ft.	Grade	Range	Thread
1800-4000	9-5/8	36	K-55	3	Buttress
4000-5000	9-5/8	40	K-55	3	Buttress
5000-6000	9-5/8	40	N-80	3	Buttress
6000-7000*	9-5/8	40	S-95	3	Buttress

* Depths are measured depths, not T.V.D.

g. Two centralizers should be installed on the bottom joint and immediate joint above it and one centralizer per joint to top of each string. A float collar and shoe are to be used on the 13-3/8 inch and 9-5/8 inch with D.V. collars on the 9-5/8 inch for cementing purposes as described in 2.2.9. Liner hanger for 9-5/8 inch should be equivalent to Brown Oil Tool's CMC multiple cone with swivel underneath, landing collar, V shoe, and double back pressure valve.

2.2.8 Casing Head Equipment

General

a. The recommended casing head equipment as shown in drawings (Appendix X) will be installed on the 13-3/8 inch casings. All materials and fittings are designed to withstand the corrosive action of steam and saline water. The casing head should have 2 inch minimum ports, and may be threaded or flanged. All flanges should be API type 6B with ring joint facing. All flanges, fittings, stud bolts, and ring gaskets should conform to the requirements of API standard 6A.

b. Materials

- (1) Casing head for 13-3/8 inch O.D. casing. The casing head should be 13-3/8 inch O.D. slip on and weld with test ports, female bottom x 12 inch, 3000 psi working pressure API flanged top. The 13-3/8 inch head should have 2000 psi working pressure ring-joints with flanged or threaded outlets.
- (2) Adapter flange should be 12 inch 3000 psi working pressure API ring-joint flange down x 10 inch 5000 psi working pressure API ring-joint flange up. Length of spool should be minimum of 18 inches.
- (3) Expansion spool for injection well shall be 12 inch psi working pressure x 10 inch 2000 psi working pressure ring-joint flange. Length of spool should be 15 inches.
- (4) The guard valve for the injection well shall be 10 inch gate valve ANSI 600 psi, with ring-joint flanges.
- (5) Gate valves - 2 inch, 2000 psi, working pressure API with ring joint flanges, or threaded for standard 2 inch pipe and trimmed for steam.

- (6) Bull plug - 2 inch, tapped and threaded for $\frac{1}{2}$ inch standard pipe
- (7) Bull plug, 2 inch
- (8) Needle Valves, $\frac{1}{2}$ inch
- (9) Companion flanges - 2 inch 2,000 psi working pressure tapped
for 2 inch line pipe.

c. Installation

Cut off 13-3/8 inch O.D. casing and install casing head so that top of reducing spool will be level with the top of the cellar. The 13-3/8 inch O.D. slip-on head shall be welded by a certified welder that has experience at this type welding. All guard valves will be installed prior to completion of work.

2.2.9 Cementing Operations

a. General.--After the contractor has drilled to casing depth, the hole should be thoroughly circulated to condition it for running and landing the casing.

b. Materials.--The slurry constituents should be as follows based on cement content: 1:1 perlite ratio, 0.6 of 1 percent cement friction reducer, 0.75 of 1 percent low water loss, 0.5 of 1 percent retarder, 2 percent gel, and 40 percent silica flour. The cement should be API Class G. The contractor should allow a waiting period of 12 hours for the cement to set before continuing.

The contractor should have on hand at the beginning of cementing operations, cement and other materials in an amount of not less than 150 percent of that theoretically required for cementing of the annulus around the casing.

All cement and additives should be in accordance with API Standards 10A "0.1 - Well Cements and Cement Additives." The following information should be plainly marked on each bag of cement and on each shipping invoice covering a shipment of bulk cement:

- (1) Manufacturer's name.
- (2) API monogram.
- (3) Class of cement.
- (4) The word "RETARDED" if the cement contains a retarder other than or in addition to calcium sulfate.

- (5) The words "MODERATE SULFATE RESISTANCE (MSR)" or "HIGH SULFATE RESISTANCE (HSR)" if the cement complies with the respective requirements for sulfate resistance.

c. Cementing operations.--Cementing should be in accordance with good oil well cementing practices and should be by the displacement method from the bottom. The 9-5/8 inch intermediate casing should be cemented by stages. Mixing equipment and pumps should be of adequate size to provide good circulation of the cement around the casing and to complete the cementing operation in the relatively high temperatures encountered without detrimental effects due to hydration of the cement.

CEMENTING SUMMARY

- I. Conductor Casing Program - 60 feet of 20 inch Casing in 26 inch Hole
We would recommend cementing this casing by the one plug method. Each of the joints of casing should be equipped with a centralizer. (API Class G cement premixed with 30 percent Silica Flour mixed at 117 lbs/cu.ft. slurry with 0.85 cu.ft. water/sack of cement to yield 1.50 cu.ft. of slurry/sack.) The theoretical slurry volume required is 90 cu.ft. and at least 100 percent excess cement (90 cu.ft.) should be allowed for a total slurry volume of 180 cu. ft.
- II. Surface Casing Program 2000 feet of 13-3/8 inch Casing in 17-1/2 inch Hole
We would recommend cementing this casing by the conventional two-plug method. The casing should be equipped with a differential fill float

collar one joint above a differential fill float shoe and with centralizers as per 2.2.7. The cement should be preceded by 2000 gallons of Mud Flush mud removal solution and a bottom cementing plug and followed by a top cementing plug. Cement with API Class G with 1 cu.ft. Perlite/sack, 40 percent Silica Flour, 2 percent Gel and retarder mixed with 1.62 cu.ft. water/sack at a density of 92 lbs./cu.ft. with an absolute yield of 2.65 cu.ft. of slurry/sack. The theoretical slurry volume required is 1320 cu.ft. The amount of excess cement used should be determined based on drilling experience, but 50 percent (660 cu.ft.) will be used for cost estimating.

III. Intermediate Casing Program - 3700 feet of 9-5/8 inch Casing in 12-1/4 inch Hole This string should also be cemented by the displacement plug method. Casing should be equipped with differential fill float collar and shoe and with centralizers as per 2.2.7. Prior experience in this area has indicated the necessity of cementing production strings in three stages by using DV cementer port collars at about 3700 and 2700 feet TVD respectively. Each stage should be preceded by 1000 gallons of Mud Flush. Assuming 50 percent excess cement, the bottom stage would require 845 cu.ft. of slurry and the second stage would require 465 cu.ft. The top stage would require 798 cu.ft. The recommended slurry would be the same as for the surface casing job.

IV. Outside Jobs

Outside jobs, if required, should be done with the same slurry recommended for the conductor casing job. A friction reducer such as D-19 could be added to increase placement rate.

2.2.10 Borehole Geophysical Logging (Appendix III)

a. General -- Borehole geophysical logging by Dresser Atlas should be as follows:

1. 0-2000 feet

(a) Gamma Ray log

2. 2000-6500 T.V.D.

(a) Dual induction - laterolog

(b) Compensated density log/gamma ray

(c) Compensated neutron porosity log/gamma ray

(d) Acoustic/Caliper Log

(e) Dipmeter 4 arm

The number of copies and field prints are to be specified by the Government. The computation (Epilog) should also be provided with porosities and permeabilities, as compiled by the Epilog process by Dresser Atlas.

b. Measurement and payment -- To be determined by the Government.

2.2.11 Underreaming Hole

a. Underreaming any portion of the hole has not been specifically mentioned in this program and is to be determined by the Government.

b. Measurement and payment --To be determined by the Government.

2.2.12 Coring and Drill-Stem Testing

a. General -- Coring and drill stem testing will be as directed by the Government. A rathole should be drilled for making drill stem tests; rathole size to be determined by the Government. All testing should utilize a double packer assembly, a reverse circulating sub, and the necessary

instruments to measure and record the formation pressure, hydrostatic pressure, flowing pressure, and the maximum temperature at the depth being tested.

(b) Payment.--To be determined by the Government.

2.2.13 Gravel Packing

(a) General.--All three of these wells are programmed to gravel pack the open hole below 9-5/8 inch casing. Actual gravel packing process is described in Appendix IX using Dresser Guiberson's Kleen Screen as the packing medium. The reason for this material over regular gravel is the higher permeabilities experienced through the pack than with regular gravel. Actual size of the material is described in Appendix IX and is based on a formation size analysis. Total amount to be used should be determined after caliper logs have been run.

(b) Payment.--Payment is to be determined by the Government.

2.2.14 Formations Difficult or Hazardous to Drill

This section includes problems of lost circulation and extra hard formations which consume more time in the total drilling process. Financial liabilities, as relates to compensation for first 24 hour period (or some other time period), cannot be determined by Dresser and should be determined by the Government.

2.2.15 Daywork

a. The daywork rate should be based on the use of the contractor's manned drilling rig furnished complete with all materials, machinery, equipment, supplies, and all necessary personnel and laborers for proper operation and maintenance of drilling rig in the performance of the specified work.

b. Maintenance of drilling rig.--In the event it is necessary to shut down the contractor's drilling rig for repairs, the Government should determine:

- (1) Number of hours (minimum) compensated per repair job,
- (2) Number of aggregate hours (minimum) compensated per well for repairs.

c. Supervision and payment should be determined by the Government.

2.2.16 Reimbursable Contractor Costs

Any and all reimbursable contractor costs should be set up by the Government prior to the actual drilling of the wells and cannot be determined by Dresser.

2.2.17 Work Stoppage

The Government shall have the right to direct the stoppage of work at any time prior to reaching the contract depth specified. The Government shall have the further right to require the well to be completed in accordance with these specifications or abandoned at any depth as set forth in 2.2.19. Immediately upon receipt of instructions from the contracting officer, the contractor shall discontinue the drilling of the well and plug and abandon or complete the well, as the contracting officer may direct. All costs for work stoppage shall be determined by the Government.

2.2.18 Cleanup

After the Government has accepted the work, the contractor shall clean up the well site in accordance with 1.1.3 or as directed by the Government.

2.2.19 Plugging and Abandonment

In the event the contracting officer orders the hole to be plugged and abandoned, the contractor shall P. & A. in a manner and method prescribed by the contracting officer, and shall clean up the drill site location as set forth in 2.2.18. Federal and State of California regulations shall be observed in the actual P. & A. procedure.

2.2.20 Tubing Installation

For the three wells being programmed, the use of tubing has not been considered, as production and injection are to be confined within casing. Any tubing to be used and costs of same shall be under the direction of the Government.

2.2.21 Tubing Head and Hanger

Refer to 2.2.20.

APPENDIX I

APPENDIX I
DIRECTIONAL DRILLING

A. GENERAL

All drilling practices are to be consistent with drilling methods and practices (2.2.4). Kick off point on both wells is immediately below 13 3/8 casing. Build-up rate is recommended at 2°/100' of measured depth (MD). Actual build up rates, azimuth, and direction to be determined by directional driller at well site.

B. PRODUCING WELL - 2000' Throw

<u>MD</u>	<u>TVD</u>	<u>THROW</u>	<u>TOTAL ANGLE</u>
2000	2000	0	0
2100	2099.93	3.49	2
2200	2199.68	10.46	4
2300	2299.14	20.91	6
2400	2398.17	34.83	8
2500	2496.65	52.50	10
2600	2594.46	72.99	12
2700	2691.49	97.18	14
2800	2787.62	124.74	16
2900	2882.72	155.64	18
3000	2976.69	189.84	20
3100	3069.41	227.30	22
3200	3160.76	267.97	24
Maintain 24° angle to measured depth of 6961.71 - Total throw will be 2000'			
6962	6500	2000	24

C. PRODUCER/INJECTOR - 4000' THROW

<u>MD.</u>	<u>TVD</u>	<u>THROW</u>	<u>TOTAL ANGLE</u>
2000	2000	0	0
2100	2099.93	3.49	2
2200	2199.68	10.46	4
2300	2299.14	20.91	6
2400	2398.17	34.83	8
2500	2496.65	52.50	10
2600	2595.46	72.99	12
2700	2691.49	97.18	14
2800	2787.62	124.74	16
2900	2882.72	155.64	18
3000	2976.69	189.84	20
3100	3069.41	227.50	22
3200	3160.76	267.97	24
3300	3250.64	311.81	26
3400	3338.93	358.76	28
3500	3425.54	408.76	30
3600	3510.34	461.75	32
3700	3593.25	517.67	34
3800	3674.15	576.45	36
3900	3752.95	638.02	38
4000	3829.55	702.30	40
4100	3903.87	769.21	42
4200	3975.80	838.68	44
4300	4045.27	910.61	46
4400	4112.18	984.92	48

Maintain 48⁰ angle to measured depth of 8246' - Total Throw will be 4000'

8246	6500	4000	48
------	------	------	----

APPENDIX II



SUGGESTED MUD PROGRAM

COMPANY: U.S. Bureau of Reclamations WELL NAME: _____

LOCATION: East Mesa Prospect COUNTY, STATE: California

SUGGESTED CASING PROGRAM:

- Drill 26" hole - set 20" csg. @ 60'
- Drill 17 1/2" hole - set 13 3/8" csg. @ 2000'
- Drill 12 1/4" hole - set 9 5/8" csg. @ 5500'
- Drill 8 1/2" hole

SUGGESTED MUD PROPERTIES:

Mud Type: Magcogel-Benex

Depth	Weight	Viscosity	Fluid Loss	pH	Treatment/Remarks
0'-2000'	65-67#/cu. ft.	50-60 sec./qt.	n/a	9.0-9.5	

Drill surface hole with sufficient viscosity to clean the well bore to run and land 13 3/8" csg. Solids control equipment should be installed at beginning of this interval to control drill solids to keep mud weight from building up to ranges that can cause lost returns.

A surface system of approximately 1000-1200 bbls. will be made up of Magcogel, Caustic Soda for pH control, and Benex (a flocculent and an extender).

Estimated mud material cost of 0'-2000' - \$3500.00

Estimated Drilling Time - 2 Days

Estimated mud cost/ft. - \$1.75/ft.

NOTE: SEE REVERSE SIDE FOR LIABILITY CLAUSE



SUGGESTED MUD PROGRAM

SUGGESTED MUD PROPERTIES:

Mud Type: Thermogel

Depth	Weight	Viscosity	Fluid Loss	PV	Treatment/Remarks	VP	pH
2000-5500	65-67# /cu.ft.	38-40	15 cc or less	12		8	9.0-9.5

Before drilling out of 13 3/8" csg., clean mud tanks of all drill solids. Rebuild volume and maintain viscosity starting at this interval with additions of Thermo-Gel. Control fluid loss with additions of Cypan and Resinex. Control pH with Caustic Soda. Treat cement contamination when drilling out of 13 3/8" csg. with Bicarbonate of Soda.

The plastic viscosity and yield point will vary according to solids content and shearing effect of rig equipment. The numbers indicated above are a guide to help keep drilling fluid in a laminar flow. The addition of Tannathin may be required as temperature increases.

Estimated drilling time for 2000' to 5500' - 10 Days

Estimated mud cost per day - \$1150.00 for 10 days - \$11,500.00

Estimated cost per foot from 2000' to 5500' - \$3.28/ft.

Make-up Concentrations:

0.5	lb./bbl.	Caustic Soda
15	lb./bbl.	Thermogel
1	lb./bbl.	Cypan
1	lb./bbl.	Resinex

NOTE: SEE REVERSE SIDE FOR LIABILITY CLAUSE



SUGGESTED MUD PROGRAM

SUGGESTED MUD PROPERTIES:

Mud Type: Thermogel

Depth	Weight	Viscosity	Fluid Loss	Treatment/Remarks	PV	VP	pH
5500-6500	65-67# /cu. ft.	40-42 sec/qt	15 cc or less		12	8	9.0-9.5

The drilling fluid make-up will be the same as the previous interval composed of Thermo-Gel, Caustic Soda, Cypan, Resinex, Magcogel, and Tannathin.

Treat cement contamination with Bicarbonate of Soda as needed when drilling out of 9 5/8" csg.

Estimated drilling time for this interval - 4 Days

Estimated mud material cost per day - \$1200.00/day

Estimated interval cost for mud - \$4800.00

Estimated mud cost/foot - \$4.80/ft.

Estimated mud cost per interval:	Drilling Time
0'-2000' - \$3500.00 - \$1.75/ft.	2 Days
2000'-5500' - \$11,500.00 - 3.28/ft.	10 Days
5500'-6500' - <u>\$4800.00</u> - <u>\$4.80/ft.</u>	<u>4 Days</u>

TOTAL

0-6500' - \$19,800.00 - \$3.05/ft. 16 Days

Estimated cost does not include costs for lost returns, taxes, or trucking.

Some advantages of Thermo-Gel are:

Temperatures of 400°F have little or no effect on the mud, therefore, no thick gelation of mud off bottom after a trip. This being of a great advantage to reduce possible lost circulation. Thermo-Gel aids in fluid loss control in high temperature holes. It is also approximately 25% acid soluble.

NOTE: SEE REVERSE SIDE FOR LIABILITY CLAUSE



SUGGESTED MUD PROGRAM

Good solids control equipment must be installed at beginning of well to be utilized throughout the drilling of the entire well. This is to insure the minimum amount of drill solids build-up in the mud, thus reducing the possibility of lost returns.

The equipment necessary to maintain minimum drill solids in the mud are:

2 Swaco 6-T4 desilters - \$65.00/day each

1 Swaco 1-12 desanders - \$45.00/day each

This equipment has the capacity of handling more than 100% of the drilling mud that is circulated from the well bore.

The rheological properties of the mud can be controlled by the mud engineer to keep the drilling mud in laminar flow while circulating the well bore in order to minimize hole erosion.

Enclosed is a hydraulic program to aid in keeping a laminar fluid and still be able to clean the well bore. This will insure less solids entering the mud system and improve the efficiency of the drilling operations. Less cement will also be required if hole is in gauge.

When drilling the directional hole, the addition of Magcolube, an effective drilling mud lubricant, can be helpful in reducing torque and drag on the drill string. It may also reduce the possibility of sticking the drill string. The recommended amount is 1#/bbl. of Magcolube to the system at the depth that deviation starts and maintain until T.D.

Directional Well #1

TVD - 6500' - length 6921'

Estimated Drilling mud costs per foot - \$3.71/ft.

Estimated Drilling mud costs for 6921' @ \$3.71 - \$25,687.00

Total Estimated cost includes Magcolube.

Magobar

DRILLING FLUID SERVICES

OILFIELD PRODUCTS DIVISION
Dresser Industries, Inc.**SUGGESTED
MUD PROGRAM**

Directional Well #2

TVD - 6500' - length 8246'

Estimated Drilling mud costs per foot - \$3.71

Total estimated mud costs for 8246' @ \$3.71 - \$30,593.00

Estimated cost includes Magcolube.

If lost returns are encountered, by letting the hole stand static for 5 to 8 hours may be helpful in regaining circulation. Additions of fine mica and fine nut plug can be used to aid in restoring circulation.

DRESSER OILFIELD PRODUCTS
OPTIMIZED DRILLING PROGRAM

CONTRACTOR UNKNOWN OPERATOR B . U . R.
WELL NAME UNKNOWN WELL NO.
COUNTY IMPERIAL LEGAL DESC. CALIFORNIA

PUMP (S)

PAGE 1

DEPTH	MUD WT	PV	YP	SECTION LENGTH	HOLE SIZE	PIPE DIAMETER	
						OD	ID
1000	9.0	6	20	700	17.500	4.500	3.810
				300	17.500	9.000	3.000
2000	9.0	6	20	1700	17.500	4.500	3.810
				300	17.500	9.000	3.000
3000	9.0	12	8	2000	12.515	4.500	3.810
				500	12.250	4.500	3.810
				500	12.250	7.750	3.000
4000	9.0	12	8	2000	12.515	4.500	3.810
				1500	12.250	4.500	3.810
				500	12.250	7.750	3.000
5000	9.0	12	8	2000	12.515	4.500	3.810
				2500	12.250	4.500	3.810
				500	12.250	7.750	3.000
6000	9.0	12	8	2000	12.515	4.500	3.810
				3500	12.250	4.500	3.810
				500	12.250	7.750	3.000
7000	9.0	12	8	2000	12.515	4.500	3.810
				4500	12.250	4.500	3.810
				500	12.250	7.750	3.000
7500	9.0	12	8	1800	12.515	4.500	3.810
				5200	8.750	4.500	3.810
				500	8.500	6.000	2.700

DRESSER DILFIELD PRODUCTS
OPTIMIZED DRILLING PROGRAM

PAGE 2

DEPTH	MUD WT	PV	YP	SECTION LENGTH	HOLE SIZE	PIPE DIAMETER OD	ID
8000	9.0	12	8	1800	12.515	4.500	3.810
				5200	8.755	4.500	3.810
				500	8.500	4.500	3.810
				500	8.500	6.000	2.500

DRESSER OILFIELD PRODUCTS
OPTIMIZED DRILLING PROGRAM

LINER SIZE= 7.00
STROKE LNG= 16.00

PAGE 3

DEPTH	N	K	CRITICAL VELOCITY (COLLAR)	ANNULAR VELOCITY (COLLAR)	GPM @ AV	SPM
1000	0.30	4.01	203	123	1128	126
2000	0.30	4.01	203	99	908	102
3000	0.68	0.29	123	123	453	51
4000	0.68	0.29	123	123	453	51
5000	0.68	0.29	123	123	453	51
6000	0.68	0.29	123	123	453	51
7000	0.68	0.29	123	123	453	51
CHANGE LINERS TO				5.50 INCH		
7500	0.68	0.29	167	167	247	44
8000	0.68	0.29	167	167	247	44

DRESSER OILFIELD PRODUCTS
OPTIMIZED DRILLING PROGRAM

ANALYSIS OF PRESSURE LOSSES

PAGE 4

DEPTH	PSI LOSS ANNULUS	PSI LOSS DRILL STRING	PSI LOSS SURF EQ	PSI LOSS BIT	PUMP PSI
1000	3	651	179	1633	2466
2000	6	697	120	1662	2485
3000	5	295	33	1945	2278
4000	6	367	33	1945	2351
5000	8	439	33	1945	2424
6000	9	511	33	1945	2498
7000	10	583	33	1732	2359
7500	30	253	11	1967	2260
8000	32	265	11	1967	2274

DRESSER DILFIELD PRODUCTS
OPTIMIZED DRILLING PROGRAM

PAGE 5

ZONE NO.	DEPTH (FEET)	MUD WT (PPG)	-----ANNULAR-----			ECD (PPG)	EQUIV FANN RPM	RE NO.
			VELOCITY (FT/MIN)	PRESS (PSI)	VIS (CPS)			
1	700	9.0	97	2	272	9.1	10	642
	1000	9.0	123	3	171	9.1	20	848
2	1700	9.0	78	4	317	9.0	8	444
	2000	9.0	99	6	199	9.1	16	587
3	2000	9.0	81	2	53	9.0	14	1708
	2500	9.0	86	3	52	9.0	16	1782
	3000	9.0	123	5	39	9.0	39	2000
4	2000	9.0	81	2	53	9.0	14	1708
	3500	9.0	86	4	52	9.0	16	1782
	4000	9.0	123	6	39	9.0	39	2000
5	2000	9.0	81	2	53	9.0	14	1708
	4500	9.0	86	6	52	9.0	16	1782
	5000	9.0	123	8	39	9.0	39	2000

DRESSER DILFIELD PRODUCTS
OPTIMIZED DRILLING PROGRAM

PAGE 6

ZONE NO.	DEPTH (FEET)	MUD WT (PPG)	-----ANNULAR-----			ECD (PPG)	EQUIV FANN RPM	RE NO.
			VELOCITY (FT/MIN)	PRESS (PSI)	VIS (CPS)			
6	2000	9.0	81	2	53	9.0	14	1708
	5500	9.0	86	7	52	9.0	16	1782
	6000	9.0	123	9	39	9.0	39	2000
7	2000	9.0	81	2	53	9.0	14	1708
	6500	9.0	86	8	52	9.0	16	1782
	7000	9.0	123	10	39	9.0	39	2000
8	1800	9.0	44	1	65	9.0	8	765
	7000	9.0	107	23	40	9.1	36	1599
	7500	9.0	167	30	29	9.1	94	2000
9	1800	9.0	44	1	65	9.0	8	765
	7000	9.0	107	23	40	9.1	36	1599
	7500	9.0	116	25	38	9.1	41	1707
	8000	9.0	167	32	29	9.1	94	2000

DRESSER DILFIELD PRODUCTS
OPTIMIZED DRILLING PROGRAM

PAGE 8

DEPTH	JET VELOCITY (FT/SEC)	JET IMPACT (LBF)	JET HHP	SYSTEM HHP	JETS	% HHP @ BIT
1000	450	2357	1074	1623	18 18 20	66.2
2000	454	1914	880	1316	16 16 18	66.9
3000	491	1034	514	603	11 11 12	85.4
4000	491	1034	514	622	11 11 12	82.7
5000	491	1034	514	641	11 11 12	80.2
6000	491	1034	514	661	11 11 12	77.9
7000	463	975	458	624	11 12 12	73.4
7500	494	566	283	326	8 8 9	87.0
8000	494	566	283	328	8 8 9	86.5

APPENDIX III

BOREHOLE GEOPHYSICAL LOGGING

WELL @ 8246' 48° ANGLE

Service Charge	\$ 350.	\$ 350.00	
Gamma Ray Log	0-2000'	<u>470.00</u>	
		<u>\$ 820.00</u>	Surface Run
Service Charge	\$ 350.		
Dual induction-laterolog	2,952.		
Compensated density log/gamma ray gamma ray	2,838. <u>567.</u>		
Compensated neutron porosity log/ gamma ray	3,002. 567.		
Acoustic/Caliper (Sonic) Log	2,838.		
Dipmeter 4 arm	4,270.		
Computation (Epilog)	<u>2,480.</u>		

TOTAL

Dresser Atlas estimated
cost for logging \$ 20,684.00

BOREHOLE GEOPHYSICAL LOGGING

WELL @ 6500' STRAIGHT HOLE

Service Charge	\$ 350.	\$ 350.
Gamma Ray Log		<u>470.</u>
		<u>\$ 820.</u>
Service Charge	\$ 350.	
Dual induction-laterolog	2,340.	
Compensated density log	1,985.	
gamma ray	385.	
Compensated neutron porosity log	2,115.	
gamma ray	385.	
Acoustic/Caliper (sonic)	1,985.	
Dipmeter	3,225.	
Computation (Epilog)	1,800.	
Hy Temp	<u>325.</u>	
	\$ 12,715.	

BOREHOLE GEOPHYSICAL LOGGING

WELL @ 6962' 24° ANGLE

Service Charge	\$ 350.	\$ 350.	
Gamma Ray Log		<u>470.</u>	
		\$ 820.	Surface Run
Service Charge	\$ 350.		
Dual induction-laterolog	2,478.		
Compensated density log	2,090.		
gamma ray	406.		
Compensated neutron porosity log	2,226.		
gamma ray	406.		
Acoustic/Caliper (sonic)	2,090.		
Dipmeter	3,348.		
Hy Temp	325.		
Computation charge	<u>1,920.</u>		
	\$16,459.		

APPENDIX IV

PLOT TITLE: **DAYS vs. DEPTH**
WELL NAME: **East Mesa**
COUNTY: **Imperial** STATE **Cal.**
LEGAL DESCRIPTION: _____

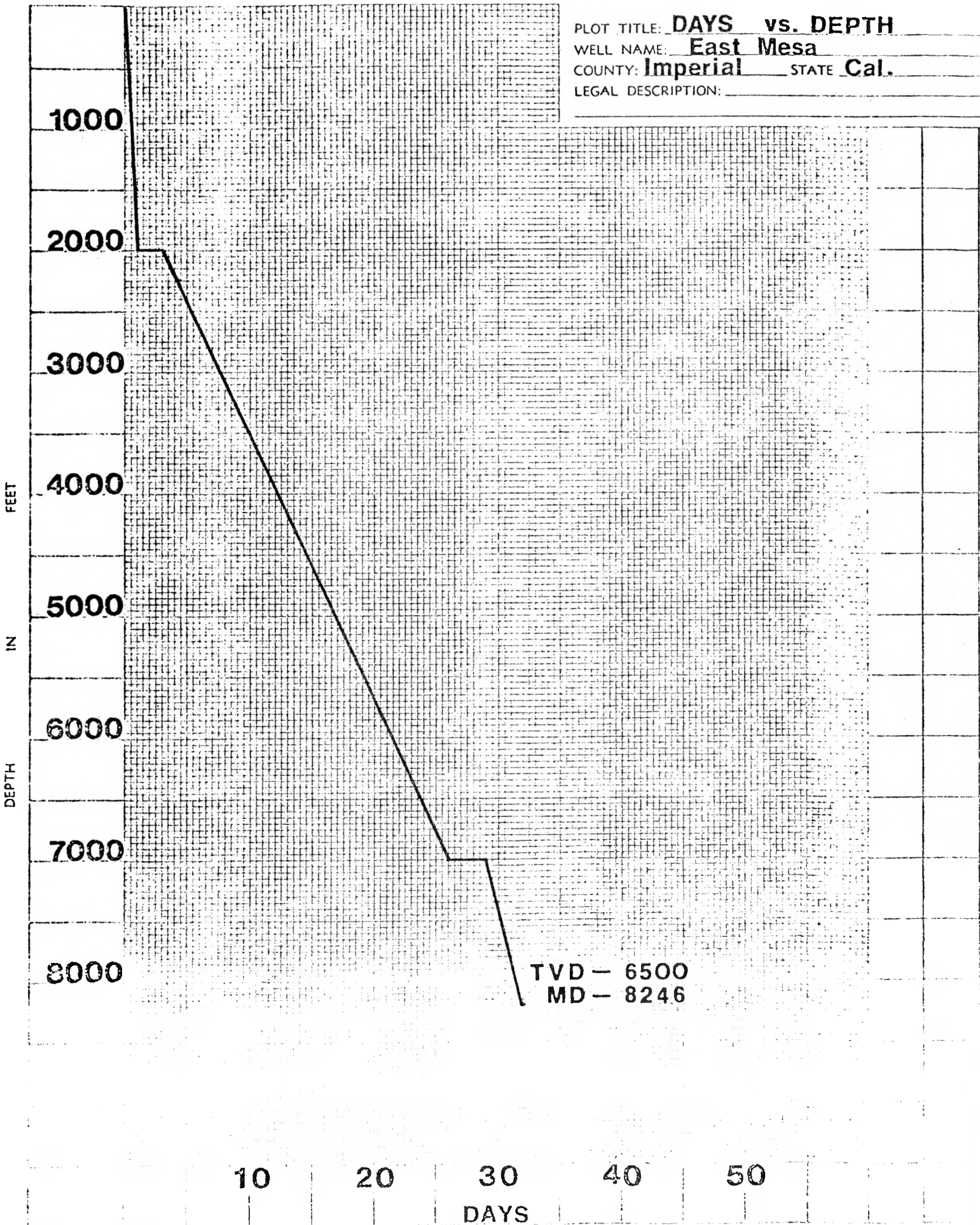

TVD - 6500
MD - 8246

PLOT TITLE: **DAYS vs. DEPTH**
WELL NAME: **East Mesa**
COUNTY: **Imperial** STATE **Cal.**
LEGAL DESCRIPTION: _____

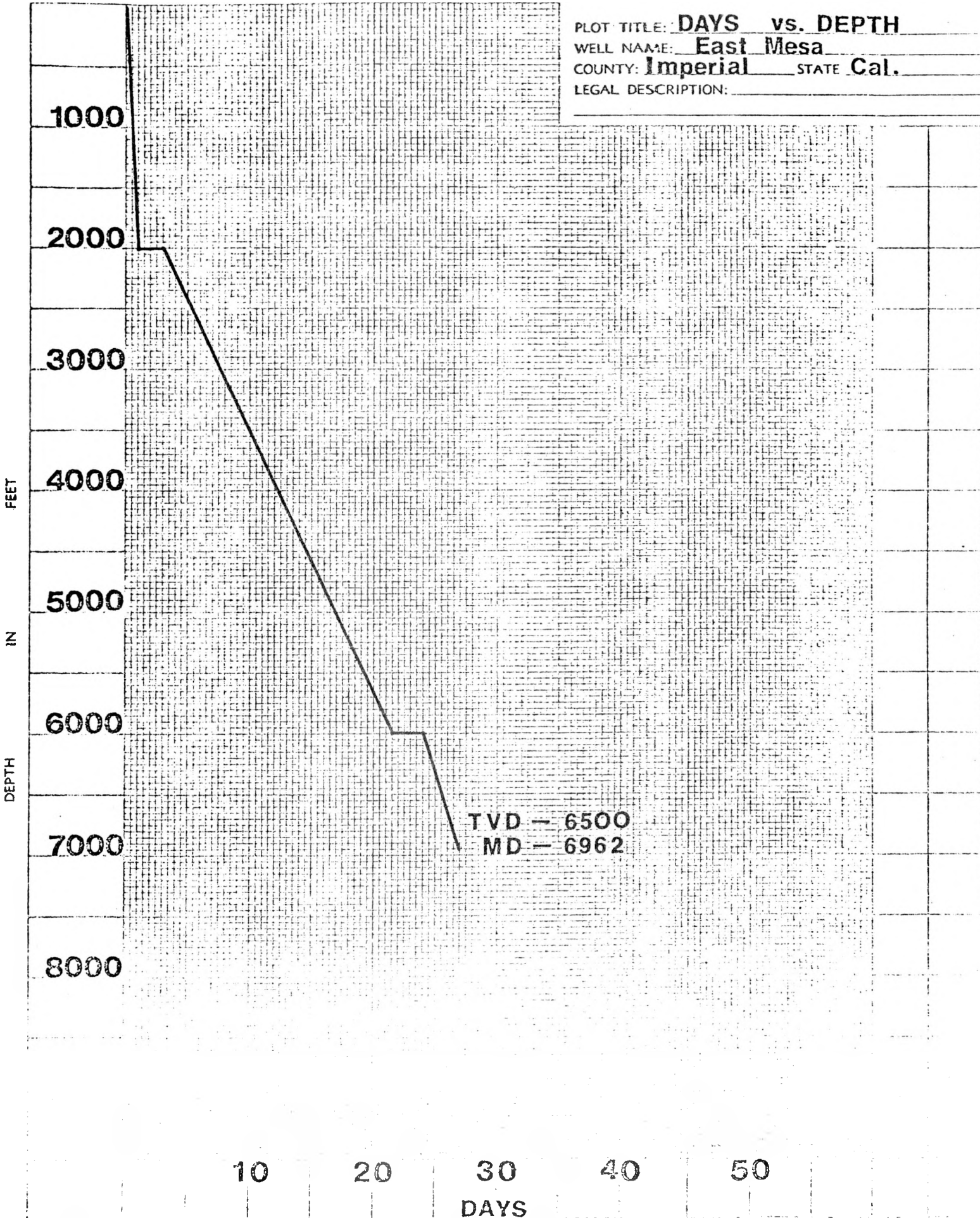

PLOT TITLE: DAYS vs. DEPTH
WELL NAME: East Mesa
COUNTY: Imperial STATE Cal.
LEGAL DESCRIPTION: _____

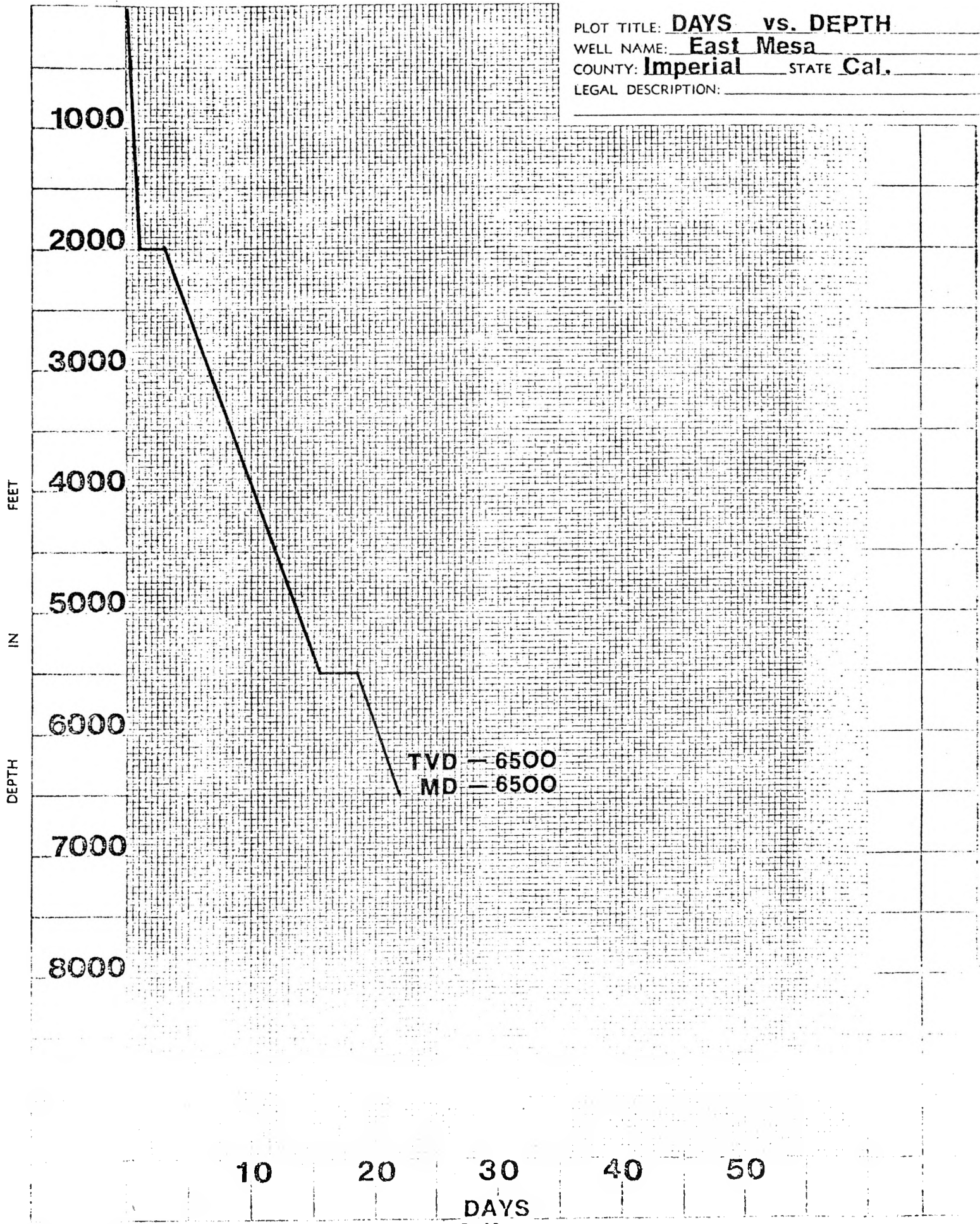

TVD — 6500
MD — 6500

10 20 30 40 50

DAYS
B-49

APPENDIX V

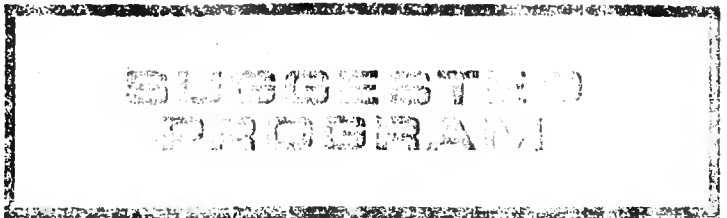

U. S. Bureau of Reclamation
East Mesa Field
Imperial Valley, California

NOTES:

1. The energy levels (weight and rpm) applied to the bits on offset wells were below the normally expected ranges for the size bits involved. This may, however, have been necessary in order to control hole direction. If this was not the case, higher energy levels may be applied to the bits, (in particular, more weight).
2. In this interval of the well, some of the formations encountered may require an M4NJ type bit.

Security

ROCK BITS & DRILL TOOLS

OILFIELD PRODUCTS DIVISION
Dresser Industries, Inc.

ROCK BIT REQUIREMENTS

DATE: July 16, 1976

COMPANY: U.S. Bureau of Reclamation WELL NAME: East Mesa Field

LOCATION: _____ COUNTY, STATE: Imperial Valley, California

ROCK BIT ESTIMATE

	<u>SIZE</u>	<u>TYPE</u>	<u>QUANTITY</u>	<u>UNIT COST</u>	<u>TOTAL COST</u>
#1	17-1/2"	S3SJ	1	\$ 1983	\$ 1983
	12-1/4"	S3J	6	756	4536
	8-1/2"	S4TJ	5	446	2230
				Total Estimated Cost =	\$ 8749
#2	17-1/2"	S3SJ	1	\$ 1983	\$ 1983
	12-1/4"	S3J	7	756	5292
	8-1/2"	S4TJ	5	446	2230
				Total Estimated Cost =	\$ 9505
#3	17-1/2"	S3SJ	1	\$ 1983	\$ 1983
	12-1/4"	S3J	9	756	6804
	8-1/2"	S4TJ	5	446	2230
				Total Estimated Cost =	\$ 11077

PREPARED BY:

A P P E N D I X VI

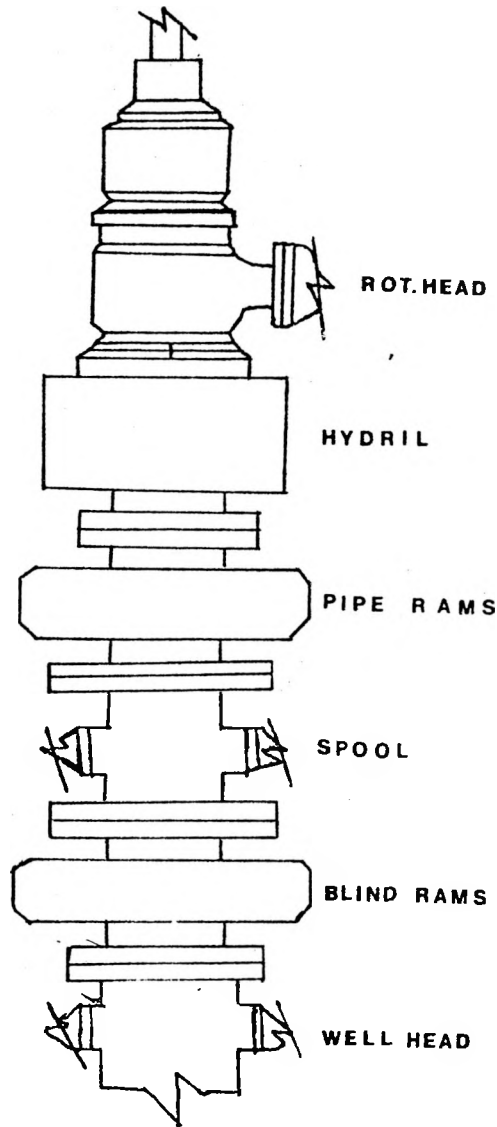

RECOMMENDED B.O.P. ARRANGEMENT FOR 13 3/8" CASING

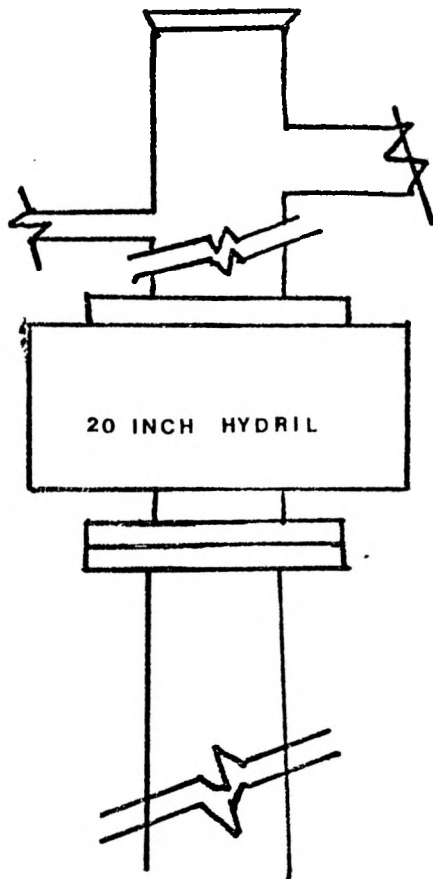

RECOMMENDED B.O.P. ARRANGEMENT FOR 20" CASING

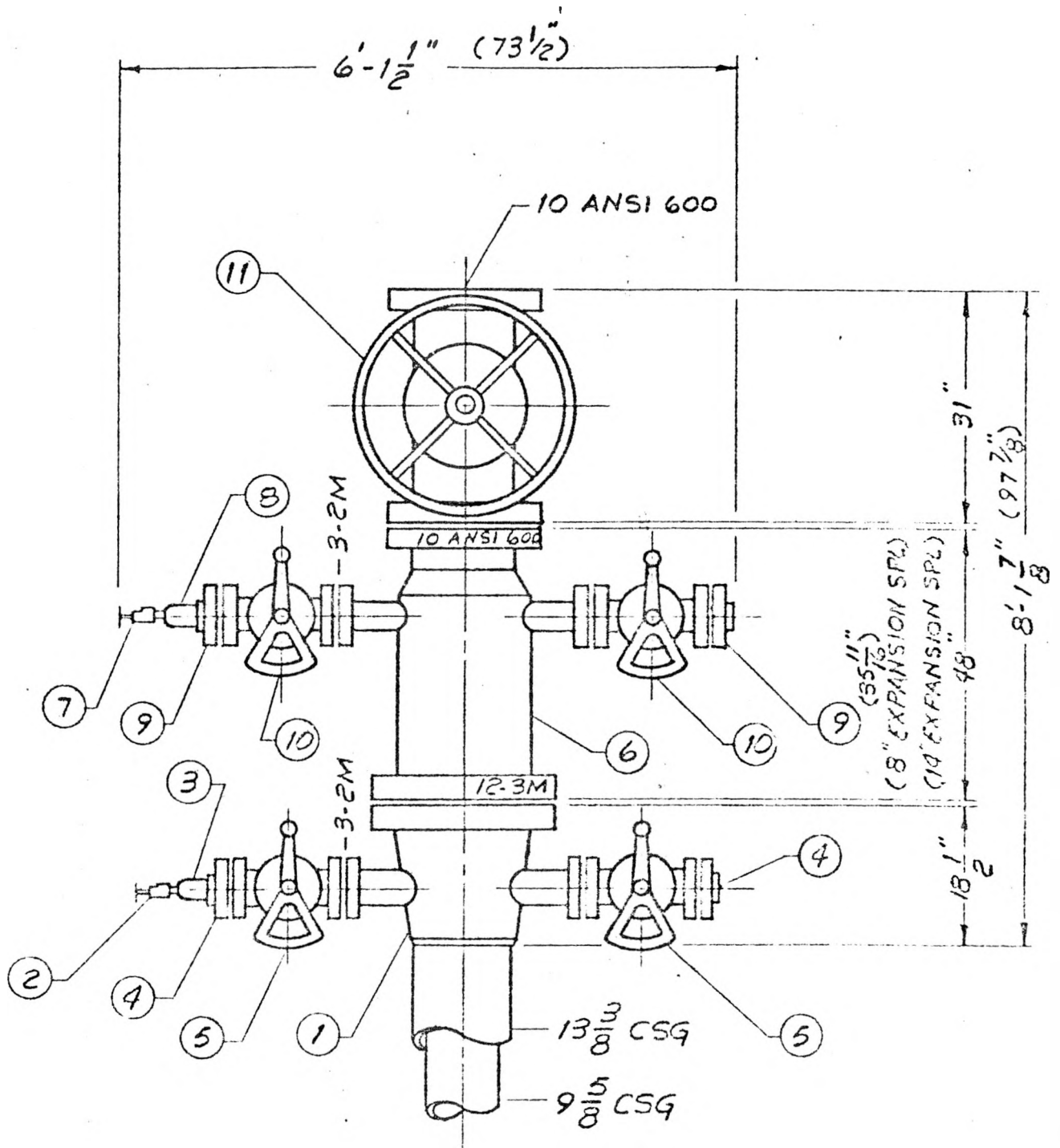

			AP-GEOTHERMAL WELL CONTROL, 2M# W.P., 13 3/8 X 9 5/8 CSQ.		DR. H.T. TR. CH. <i>HT</i>
					DATE 7-21-76
					SCALE: 1"=20" <i>A</i>
			W-K-M BREWSTER WELLHEAD CO.		DWG. NUMBER
			SHREVEPORT, LA. B-59		7-427-76
REVISIONS	CH.	DATE			

A P P E N D I X V I I

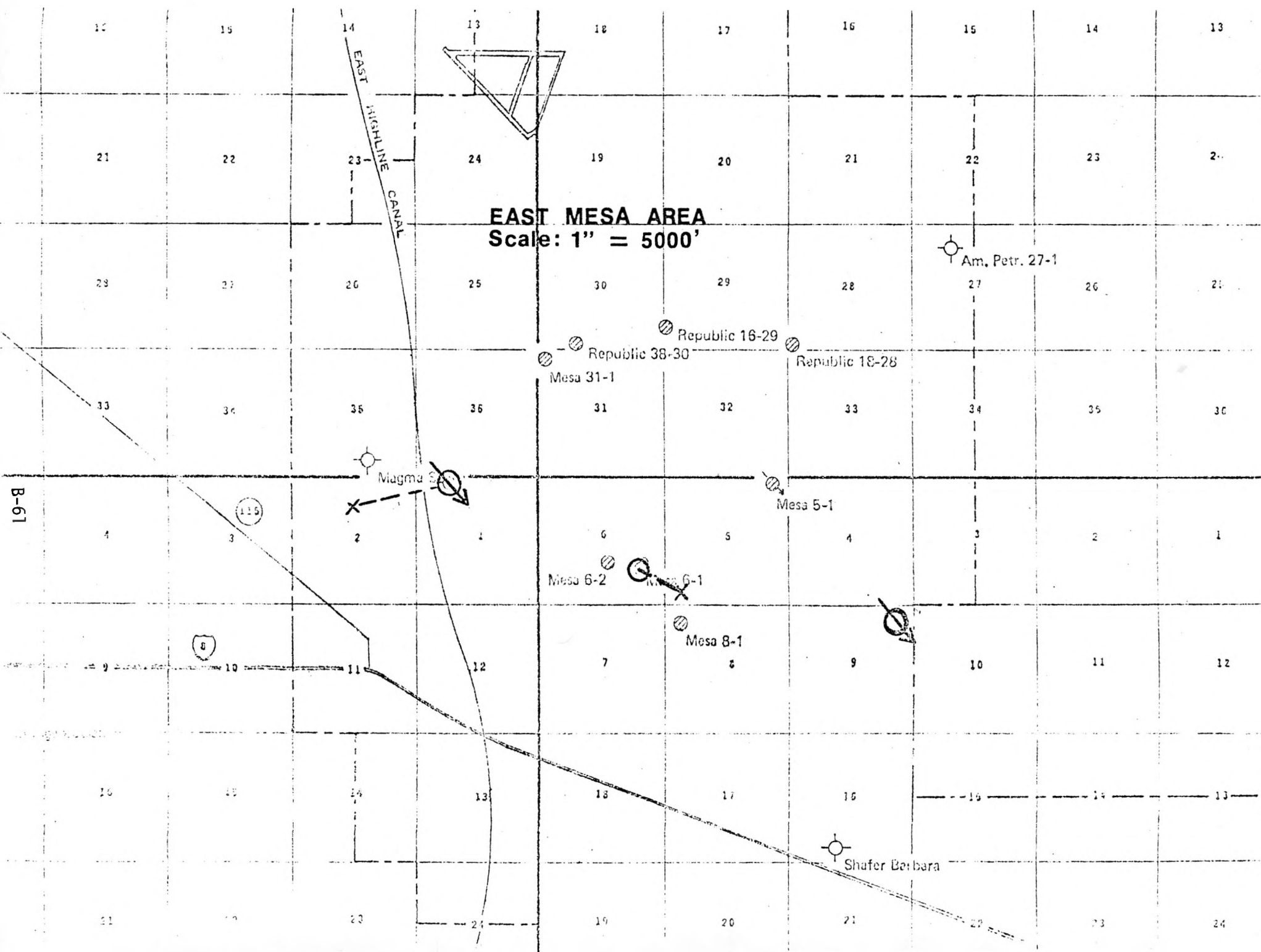

EAST MESA AREA
Scale: 1" = 5000'

EAST HIGHLINE CANAL

Am. Petr. 27-1

Republic 16-29
Republic 38-30
Mesa 31-1
Republic 18-28

Magma 5-1

Mesa 5-1

Mesa 6-2
Mesa 6-1

Mesa 8-1

Shafer Barbara

B-61

115

8

APPENDIX VIII

MATERIALS TO BE USED

IN GRAVEL PACKING

1. Howard Smith 7 inch screen, stancliff ribbed, .012 gauge.
2. Burns 9-5/8 inch by 7 inch liner hanger.
3. Port Collar - 7 inch.
4. Burns gravel packing tool with viton rubbers.
5. Burns gravel packing machine.
6. Dresser Guiberson "Kleen Screen", .015 - .03 gauge or
.012 - .020 gauge.

GRAVEL PACKING WITH BURNS LINER HANGER AND PORT COLLAR

Burns Tool Company liner hanger and port collar method of gravel packing wells is done by using Burns Tool Company lead seal liner hanger with one or more Burns rotating port collars in the production string below the liner hanger. The Burns gravel packing by-pass tool is run below the liner hanger setting tools. After hanging the liner in suspension and setting the lead seal packing element on the hanger, the port collar can be opened by using the spring loaded keys on the gravel packing tool and the gravel packing is started.

The fluid carrying the gravel is pumped into the drill pipe, it passes down through the drill pipe and out through the port collar between the packer cups on the gravel packing by-pass tool into the annulus and continues to bottom with the packing fluid.

The fluid returns up through the tail pipe to the gravel packing by-pass tool above the packing cups and comes out into the casing and returns to the surface, thus giving reverse circulation below the gravel packing tool and normal circulation above.

When the gravel is filled to the port collar, the build up on the packing pressure is noted and the well is now gravel packed to the port collar. The circulation is reversed and the excess gravel in the drill pipe is washed back through the drill pipe to the surface.

The check valve on the gravel packing tool prevents pressure against the formation. The port collar is closed and pressure tested, and the gravel packing by-pass tool is retrieved.

The Burns circulation perforation washer is run and perforations are washed from the bottom up, to settle the gravel and break down any bridges that may be formed in the gravel pack. A change over of the fluid can be made at this time.

The gravel packing by-pass tool is rerun into the liner, the port collar or port collars are reopened, and additional gravel is pumped into the well to finish packing the gravel behind the liner.

Burns rotating port collars can be used any place in the production string.

A P P E N D I X IX

RIG SPECIFICATIONS

1. Derrick - Min. gross nominal cap 490,000#. Min. static hook load of 325,000# w/10 lines.
2. Drawworks - 750 horsepower rated input.
3. Mud Pumps - 700 horsepower rated input.
4. Hook and Block - 200 ton.
5. Swivel - 200 ton.
6. Rotary - Min. 22".
7. Substructure - Must handle all equipment listed in derrick specifications and have min. setback capacity of 350,000# and have min. height of 22' to accommodate B.O.P. stack.
8. Drill Pipe - 10,000 ft. - 4½" - 16.60#/ft. Class E or above.
9. Drill Collars - Ten 7-3/4" O.D. x 3" I.D. and fifteen 6" O.D. x 2½" I.D.
10. Conventional Drift Indicator (Totco or equivalent).
11. Necessary pipe racks to store drill pipe, drill collars, and casing.
12. Normal mud storage.
13. Four circulating mud pits w/lightning mixers for sufficient agitation - Min. 1200 BBL. CAP.
14. Lighting for above rig.
15. Light Plants.
16. Dual Rig Shakers - 30 Mesh Screens.
17. Normal subs and connections for above drill pipe and drill collars.
18. All necessary pipe handling equipment for above drill pipe and drill collars - (Tongs, slips, elevators, lift nipples, safety clamps).
19. B.O.P. Stack - 12" - 900 series - 3000#
Including - 1 set pipe rams, 1 set blind rams, 1 annular preventer.
20. Auxilary Centrifugal Pumps for mud mixing.

21. Mouse Hole and Rat Hole.
22. Water Pumps and Lines.
23. Weight Indicator
24. Stand Pipe 4" I.D.
25. Kelly and Rotary Hose.
26. Upper and Lower Kelly Cock
27. Trailer for tool pusher living quarters.
28. Sand Line Unit.