

ACCELERATION OF POLARIZED PROTONS IN THE BROOKHAVEN AGS\*

BNL-29295

K.M. Terwilliger<sup>a</sup>, D.G. Crabb<sup>a</sup>, A.D. Krisch<sup>a</sup>, M. Fujisaki<sup>a</sup>, J.A. Bywater<sup>b</sup>, R.J. Lari<sup>b</sup>, L.G. Ratner<sup>b</sup>,  
E.D. Courant<sup>c,d</sup>, A. Reisman<sup>c</sup>, R. Lambiase<sup>c</sup>, Y.Y. Lee<sup>c</sup>, R.D. Ruth<sup>c,d</sup>, and L.W. Smith<sup>c</sup>

CONF-810314--83

SUMMARY

A multi-laboratory-university collaborative project involving Argonne, Brookhaven, Michigan, Rice and Yale is underway to accelerate polarized protons at the AGS. The success of the now turned off 12 GeV/c ZGS polarized beam and the design studies for the AGS<sup>1</sup> made us confident of the feasibility of achieving a polarization of about 60% at 26 GeV/c with an intensity 10<sup>11</sup> to 10<sup>12</sup> protons/pulse. Such a beam would be a potential source of polarized protons for ISABELLE. This report gives a brief discussion of the overall project and describes the tests of a prototype of the fast pulsed ferrite quadrupole magnets which will jump the intrinsic depolarizing resonances.

AGS POLARIZED PROTON PROJECT

The project has Department of Energy funding which began in FY 1980. The modifications to the Brookhaven AGS required for the acceleration of polarized protons are indicated in the layout of Fig. 1. The incremental cost for these modifications is approximately \$6 million. The time schedule is shown in Fig. 2. A major AGS change is the polarized H<sup>+</sup> source. This source is being developed at Argonne with collaboration from Yale. It uses a Cs charge exchange cell and is, expected to produce at least a 5µA H<sup>+</sup> beam, with 75% polarization, corresponding to an accelerated beam of ~ 3x10<sup>10</sup> polarized protons per pulse. The present AGS Cockcroft Walton 750 KeV preaccelerator will be modified extensively to accommodate the polarized ion source. Three polarimeters will be used to monitor the proton polarization: an initial preinjection polarimeter at 200 MeV (Rice), a thin internal target polarimeter to rapidly observe the polarization during the acceleration cycle (Michigan) and a high energy polarimeter to calibrate the extracted beam polarization (Michigan and BNL).

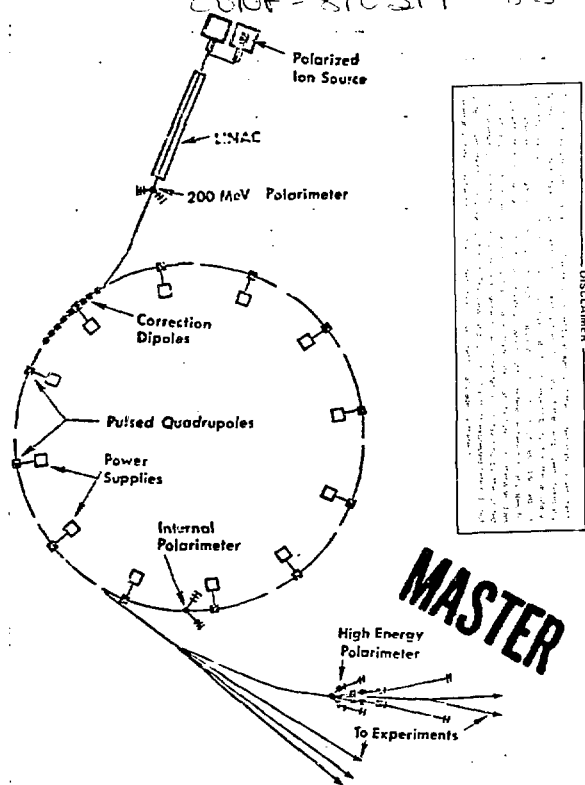

Fig. 1. AGS modifications for polarized proton acceleration.

DEPOLARIZING RESONANCES

The AGS has 96 horizontal field correction dipoles in place for handling injection field distortions. These dipoles will be programmed experimentally to exactly cancel horizontal field imperfections which can cause depolarization when there is an integral number of spin precessions per revolution, approximately every 1/2 GeV/c. The energy, calculated strength (ε), and depolarization of these imperfection resonances for typical misalignments and for normal AGS acceleration are shown in Fig. 3.<sup>2</sup> Significant depolarization would occur without correction.

The strength and depolarization of the intrinsic resonances from the horizontal components of the alternating gradient fields of the AGS are also shown in Fig. 3. The depolarization due to these intrinsic resonances can be at least partially overcome by rapid traversals of each resonance. The resonance condition is

$$\frac{g-2}{2} \nu_{res} = kP \pm v$$

where P is the machine periodicity and v the number of vertical betatron oscillations per revolution. As work performed under the auspices of the U.S. Department of Energy.

<sup>a</sup>University of Michigan, Ann Arbor, MI 48109  
<sup>b</sup>Argonne National Laboratory, Argonne, IL 60439  
<sup>c</sup>Brookhaven National Laboratory, Upton, NY 11973  
<sup>d</sup>SUNY at Stony Brook, Stony Brook, NY 11790

AGS POLARIZED PROTONS SCHEDULE

	1980	1981	1982	1983
ION SOURCE (WAL)	.....	.....	.....	.....
PREACCELERATOR (WAL)	.....	.....	.....	.....
QUADRUPOLE (QUAD)	.....	.....	.....	.....
VACUUM CHAMBER	.....	.....	.....	.....
GEN. POWER SUPPLY (GEN)	.....	.....	.....	.....
PIPE (GEN)	.....	.....	.....	.....
200 MEV POLAR. (RICE)	.....	.....	.....	.....
INTERNAL POLAR. (MICH/GEN)	.....	.....	.....	.....
H.E. POLAR. (MICH/BNL)	.....	.....	.....	.....

———— ENGINEERING DESIGN  
..... PROCUREMENT, FABRICATION  
- - - - - INSTALLATION  
..... TEST

Fig. 2. Time schedule for AGS polarized proton project. Fiscal year.

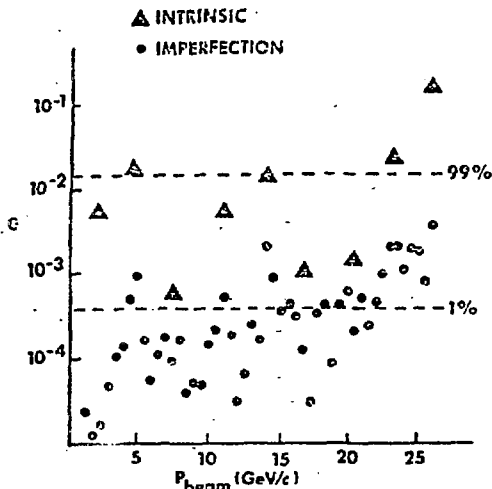

Fig. 3. ZGS depolarizing resonance strengths,  $\epsilon$ , calculated for standard acceleration and  $\pm 1$ mm misalignments.

shown in Fig. 4a, for normal acceleration  $v$  stays constant, and the rate of crossing the resonance is slow ( $\Delta t$ ). As indicated in Fig. 4b, if  $v$  is jumped quickly across the resonance, the time for resonance crossing can be sharply decreased to  $\Delta t'$ , with a consequent decrease in depolarization. The polarization losses for a  $\Delta v = .25$  jump in 2μsec are shown in Table I<sup>2,3</sup>. With these parameters reasonable polarization ( $.253 \times .75 = .64$ ) can be maintained up to 26 GeV/c.

#### PULSED QUADRUPOLES

Twelve pulsed quadrupoles, one per superperiod, will be used to jump across the intrinsic resonances. A prototype quadrupole has been designed, built and tested by a Michigan, Argonne, and BNL collaboration.

A 2μsec rise time is achieved by constructing the pulsed quads of ferrite (Ferroxcube 4L-1 W-200,  $\rho \sim 10^{-3}$  cm) available from an unused ZGS RF cavity. The ZGS RF frequency was 14mc so the ferrite clearly has adequate high frequency properties. Since the quads will be pulsed on only a few milliseconds for each resonance, heat dissipation is no problem and the current can be a thin sheet of 1/8" wires. The current sheet is parallel to the field, minimizing eddy currents in the conductors. A section view of the pulsed quad is shown in Fig. 5. The outside of the

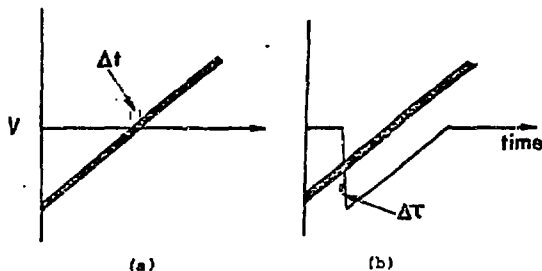

Fig. 4. a) Normal resonance crossing  
b) Rapid intrinsic resonance crossing by pulsing the vertical betatron frequency,  $v$ .

TABLE II Depolarization Due to ZGS Intrinsic Resonances  
Magnet full field risetime = 2μsec ( $4\pi/3$  radians).  
 $\delta = 0.125$ ,  $\alpha \equiv dv/d\theta = 0.0597$ ,  $v = 8.75$

$G\gamma_{res}^m$ kPzV	$\gamma_{res}$	$\epsilon$	Polarization $P/P_0$
12-v	1.81	0.0054	0.996
0+v	4.88	0.0154	0.969
24-v	8.51	0.0006	1.000
12+v	11.57	0.0054	0.996
36-v	15.20	0.0137	0.975
24+v	18.26	0.0010	1.000
48-v	21.89	0.0015	1.000
36+v	24.96	0.0266	0.911
60-v	28.86	0.1576	-----
48+v	31.65	0.0023	0.999

Resultant polarization after acceleration up to:

36+v	24.96	0.853
------	-------	-------

\*An effective fast passage through this resonance is impossible; however, slow spin flip may be possible.

vacuum chamber has a semi major axis  $a=2.5"$ , semi minor axis  $b=1.75"$ . The ferrite pole faces and conductors have hyperbolic contours. The conductors are appropriately spaced to match the boundary conditions for an ideal quadrupole field. Four wires in parallel loop each quadrant pole, and the four quadrants are in series. A computer calculation of the magnetic field distribution for a quadrant is shown in Fig. 6.

The ferrite from the ZGS was in the form of bricks epoxied together with water cooled copper conductors. Heating at 300°C for about 10 hours destroyed the epoxy strength and enabled us to disassemble the system down to the original bricks. A Q-meter test of a ferrite core indicated no appreciable change in properties due to the heat treatment. A perspective view of a ferrite quadrant is shown in Fig. 7. Four bricks are required per quadrant. The hyperbolic pole shape was obtained by final machining with diamond tool bits on a computer controlled vertical milling machine. The coil for each pole is pre-wound and then attached to the pole. The four poles and coils are then assembled around the vacuum chamber, and the coils are electrically connected.

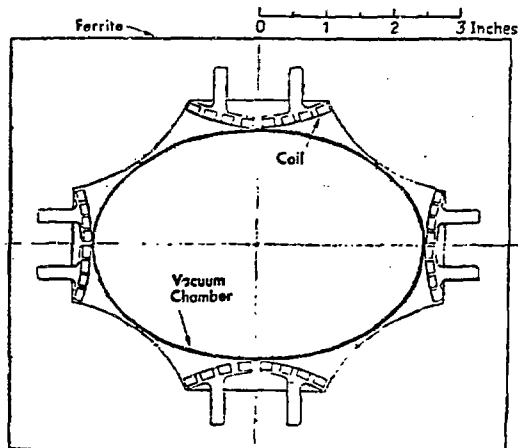

Fig. 5. Ferrite pulsed quadrupole.

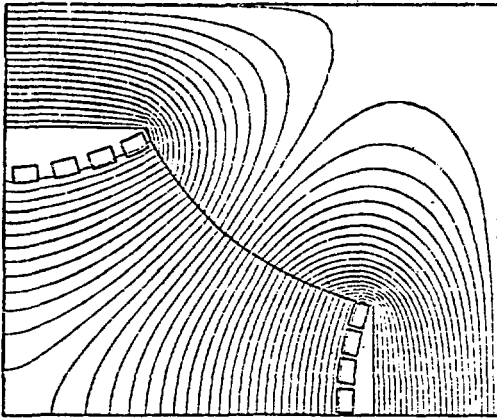

Fig. 6. Calculated magnetic field plot for pulsed quadrupoles.

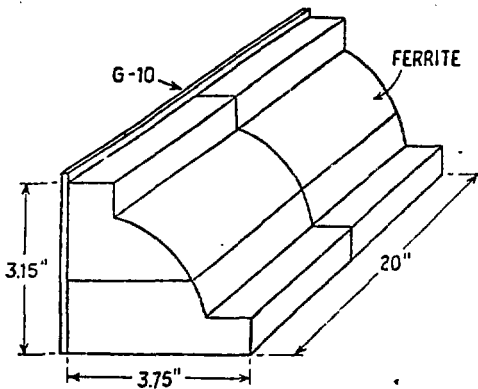

Fig. 7. Perspective view of a ferrite pole quadrant.

To test the pulsed quads, a pulsed power supply, using surplus HV supplies, ignitrons and capacitors from the ZGS, was constructed at Michigan with collaboration from Argonne and BNL. The  $\int B \cdot dl$  of the magnet was measured with a one turn search coil, extending through the magnet. A scope trace of the integrated output is shown in Fig. 8. The rise time (10% to 90%) is 1.6  $\mu\text{sec}$ , indicating that a 2 $\mu\text{sec}$  resonance crossing time can be readily achieved. The search coil also was used to examine the linearity of the field at several points during the fast rise. Measurements were made in the horizontal (x), vertical (y) and 45° directions. Results obtained at the current maximum are shown in Fig. 9. The field is linear to within ~1%, consistent with measurement errors. Plots at other times show similar linearity.

The quadrupoles are now in production at Michigan and all 14 (including 2 spares) should be constructed and tested by Oct. 1981. The power supplies are now being designed by BNL and will probably use faster hydrogen thyratron tubes as switches.

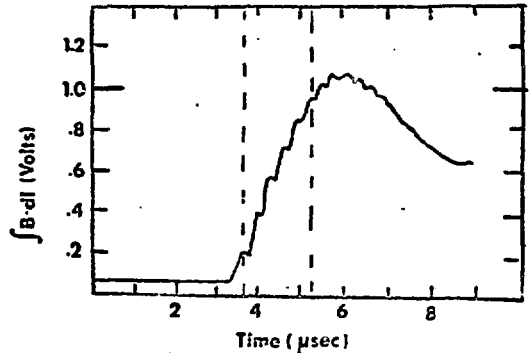

Fig. 8. Scope trace of search coil pick up signal on pulsed quad.

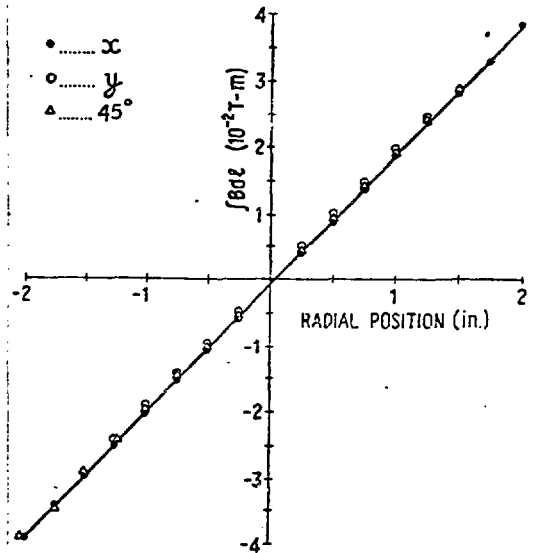

Fig. 9. Search coil pick up signal as a function of position in the pulsed quad.

#### REFERENCES

1. Preliminary Design Study for Acceleration of Polarized Protons in the Brookhaven AGS, B. Cork, E.D. Courant, D.G. Crabb, A. Feltman, A.D. Krisch, E.F. Parker, L.G. Ratner, R.D. Ruth, K.M. Terwilliger, unpublished Report 16 Oct. 1978; D.G. Crabb et al IEEE Trans. on Nuc. Sci. **NS-26**, 3203 (1979).
2. E.D. Courant, Higher Energy Polarized Proton Beams (Ann Arbor 1977), A.D. Krisch and A.J. Salchouse, Editors, AIP Conf. Proceedings No. 42, p. 94.
3. E.D. Courant and R.D. Ruth, to be published in Proceedings of 1980 Lausanne Symposium on High Energy Physics with Polarized Beams and Targets, C. Joseph Editor; BNL Accelerator Department Internal Report BNL 51270, 1980.