

314.
9-20-78
memo NTIS

10. 504

DOE/NASA CONTRACTOR REPORT

DOE/NASA CR-150534

MASTER MASTER

SIMS PROTOTYPE SYSTEM 1 - DESIGN DATA BROCHURE

Prepared by

IBM Corporation
Federal Systems Division
Huntsville, Alabama 35805

Under Contract NAS8-32036 with

National Aeronautics and Space Administration
George C. Marshall Space Flight Center, Alabama 35812

for the U. S. Department of Energy

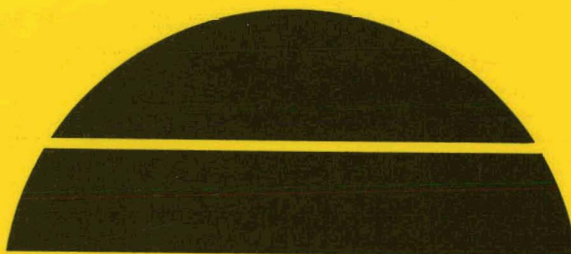

U.S. Department of Energy



Solar Energy

DISCLAIMER

This report was prepared as an account of work sponsored by an agency of the United States Government. Neither the United States Government nor any agency Thereof, nor any of their employees, makes any warranty, express or implied, or assumes any legal liability or responsibility for the accuracy, completeness, or usefulness of any information, apparatus, product, or process disclosed, or represents that its use would not infringe privately owned rights. Reference herein to any specific commercial product, process, or service by trade name, trademark, manufacturer, or otherwise does not necessarily constitute or imply its endorsement, recommendation, or favoring by the United States Government or any agency thereof. The views and opinions of authors expressed herein do not necessarily state or reflect those of the United States Government or any agency thereof.

DISCLAIMER

Portions of this document may be illegible in electronic image products. Images are produced from the best available original document.

NOTICE

This report was prepared to document work sponsored by the United States Government. Neither the United States nor its agents the United States Department of Energy, the United States National Aeronautics and Space Administration, nor any federal employees, nor any of their contractors, subcontractors or their employees, make any warranty, express or implied, or assume any legal liability or responsibility for the accuracy, completeness, or usefulness of any information, apparatus, product or process disclosed, or represent that its use would not infringe privately owned rights.

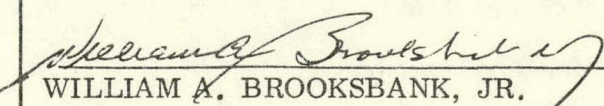
1. REPORT NO. DOE/NASA CR-150534		2. GOVERNMENT ACCESSION NO.		3. RECIPIENT'S CATALOG NO.	
4. TITLE AND SUBTITLE SIMS Prototype System 1 - Design Data Brochure				5. REPORT DATE January 1978 (Rev.)	
				6. PERFORMING ORGANIZATION CODE	
7. AUTHOR(S)				8. PERFORMING ORGANIZATION REPORT # IBM No. 7933447	
9. PERFORMING ORGANIZATION NAME AND ADDRESS IBM Corporation Federal Systems Division Huntsville, Alabama 35805				10. WORK UNIT NO.	
				11. CONTRACT OR GRANT NO. NAS8-32036	
12. SPONSORING AGENCY NAME AND ADDRESS National Aeronautics and Space Administration Washington, D. C. 20546				13. TYPE OF REPORT & PERIOD COVERED Contractor Report	
				14. SPONSORING AGENCY CODE	
15. SUPPLEMENTARY NOTES This work was performed under the technical management of Earle G. Harris, Marshall Space Flight Center, Alabama 35812.					
16. ABSTRACT This document describes a prototype solar heating and hot water system using air as the collector fluid and a pebble bed for heat storage. The system was designed for installation into a single family dwelling. Described are the system, subsystem, and installation requirements. System operation and performance are discussed, and a procedures for sizing the system to a specific site is presented.					
17. KEY WORDS			18. DISTRIBUTION STATEMENT Unclassified-Unlimited  WILLIAM A. BROOKSBANK, JR. Manager, Solar Heating and Cooling Project Ofc		
19. SECURITY CLASSIF. (of this report) Unclassified		20. SECURITY CLASSIF. (of this page) Unclassified		21. NO. OF PAGES 66	22. PRICE NTIS

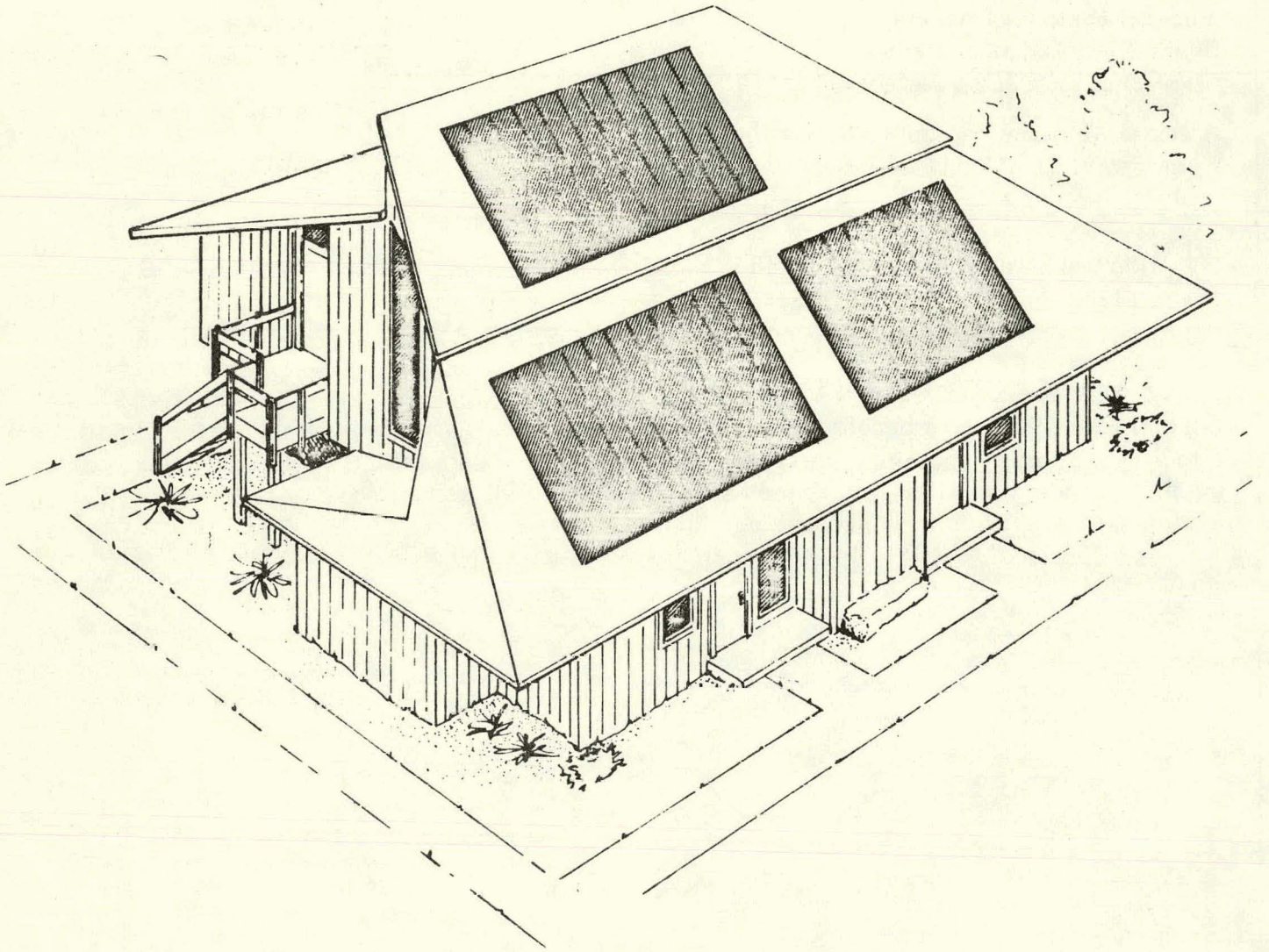

SIMS SYSTEM 1/A

Office Building for the

Home Builders Association of Huntsville, AL

IBM / WYLE LABORATORIES / SH
&G

Design Data Brochure

- TABLE OF CONTENTS -

<u>Section</u>	<u>Title</u>	<u>Page</u>
1	System Description	1
2	System Performance and Installation Consideration	5
3	Subsystem's Description	9
3-1	Collector Subsystem	10
3-2	Energy Storage Subsystem.	17
3-3	Energy Transport Subsystem.	21
3-4	Domestic Hot Water Subsystem.	22
3-5	Control Subsystem	24
3-6	Auxiliary Energy Subsystem.	29
3-7	Integration Subsystem	30
4	System Operation.	33
5	System Sizing	39
6	References.	65

NOTICE

This report was prepared as an account of work sponsored by the United States Government. Neither the United States nor the United States Department of Energy, nor any of their employees, nor any of their contractors, subcontractors, or their employees, makes any warranty, express or implied, or assumes any legal liability or responsibility for the accuracy, completeness or usefulness of any information, apparatus, product or process disclosed, or represents that its use would not infringe privately owned rights.

List of Illustration

<u>Figure</u>	<u>Title</u>	<u>Page</u>
1-1	Typical Solar Heating and Hot Water System using Air type collectors	1
1-2	Principal Elements of system.	2
3-1	Solar Energy Products, Model EF-212 Collector (Air type).	10
3-2	EF-212 Air Collector Interconnections	11
3-3	"Drop-in" Mounting.	11
3-4	Details of EF-212 Collectors.	12
3-5	Performance of EF-212 Collectors for any value of Solar Insolation.	13
3-6	EF-212 Collector Heat Output vs Ambient Temperature for Various Values of Solar Insolation.	14
3-7A	Roof Mounting Details of EF-212 Collectors.	15
3-7B	Roof Mounting Details of EF-212 Collectors.	16
3-8	Typical Heat Storage Unit Construction	18
3-9	Pebble Bed Heat Storage Capacity.	18
3-10	Solar Air Handler	21
3-11	Domestic Hot Water Subsystem.	22
3-12	Typical Control Schematic	26
3-13	Interconnecting Field Wiring for System 1A.	27
3-14	Control Subsystem and Temperature Sensors.	28
4-1	System Flow Diagram	34
4-2	Modes of Operation.	35
5-1	Basic Diagram of System 1A.	39
5-2	Dimensionless Parameters for D_1 and D_2	61
5-3	Correction Factor for K_1	64

List of Tables

<u>Table</u>	<u>Title</u>	<u>Page</u>
3-1	Subsystem Summary	9
3-2	Summary of System Conditions/Parameters	25
5-1	Monthly Values for K_t	58
5-2	62

SYSTEM DESCRIPTION ¹

Prototype System 1 has been designed by IBM under contract NAS8-32036 to NASA Marshall Space Flight Center as a solar heating and hot water preheat system for a single family dwelling. The system uses air collectors and a pebble bed storage. Domestic water is preheated with a heat exchanger in the hot air duct.

Figure 1-1 is a pictorial illustration of the system, which was designed for installation on a dwelling in the 1500 to 2500 square foot range. The design can be scaled up or down to accommodate a wide range of heating and hot water requirements for other single family, multi-family or commercial buildings without significant change to the design concept.

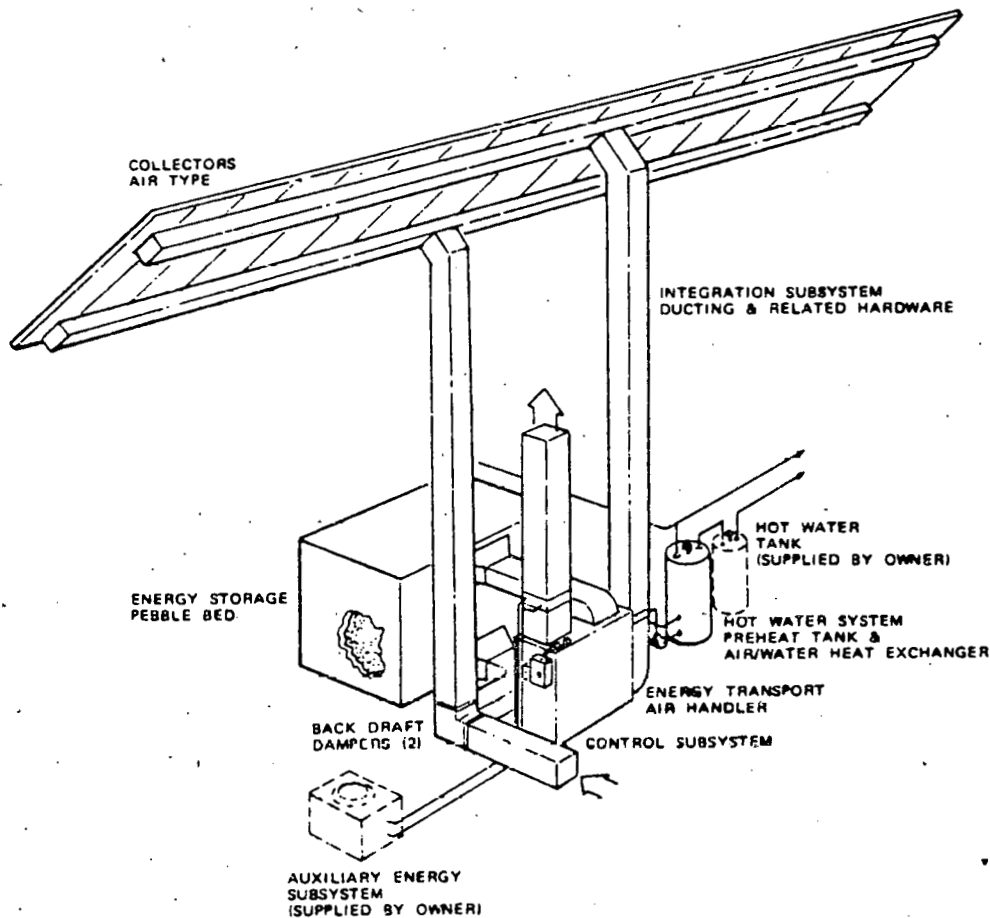

Figure 1-1. Typical Solar Heating and Hot Water System using Air type collectors.

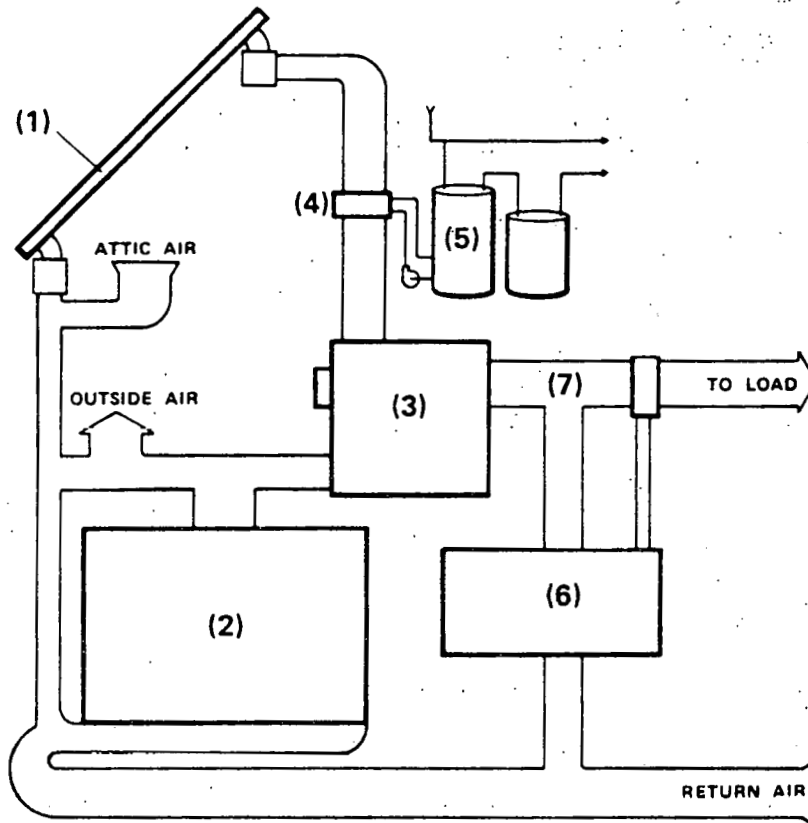

Figure 1-2. Principal Elements of system.

Principal elements of the system are (1) flat plate air type solar collectors, (2) a pebble bed for thermal storage of collected solar energy, (3) an air handling unit to move and direct the air through the energy transport system, (4) an air-to-water heat exchanger and circulating pump to allow for transfer of heat from the collector/storage circuit to the domestic hot water circuit, (5) a domestic hot water pre-heat tank for storage and transfer of collected energy into the conventional domestic water heater, (6) an air-to-air heat pump and electric strip heaters to supply auxiliary energy during periods of insufficient solar insolation, and (7) a ducting system to convey the solar heated air between system components and into the heated space. These elements are shown in Figure 1-2 (above).

The elements of the system are arranged into subsystems and are described in Section 3 , Subsystem Descriptions. Performance and Installation Considerations, Section 2 , presents design parameters for a system application in Huntsville, Alabama.

System control philosophy and the specific devices utilized to implement this philosophy are discussed in Section 4 , System Operation. Section 5 identifies the system requirements and the analytical methods and sizing procedures used in designing the system to meet these requirements.

Applicable Documents

<u>Title</u>	<u>IBM Number</u>
System Performance for SIMS Prototype SHAC System Design No. 1	7933444
System 1 Design - Heating and Hot Water Collector Subsystem Specification	7933608
Energy Storage Subsystem	7933609
Energy Transport Subsystem	7933610
Hot Water Subsystem	7933611
Control Subsystem	7933612
Auxiliary Energy Subsystem	7933613
Integration Subsystem	7933614
Installation Drawings - System 1A	7933615
Installation Drawings - System 1B	7933617
Installation Manuals - System 1A	7933618
Installation Manuals - System 1B	7933626
Operation & Maintenance Manuals - System 1A	7933627
Operation & Maintenance Manuals - System 1B	7933628
	7933629

THIS PAGE
WAS INTENTIONALLY
LEFT BLANK

SYSTEM PERFORMANCE AND **2** INSTALLATION CONSIDERATIONS

The performance of any heating system is influenced to a large degree by the integration of the system with the total building design and the construction of the building. This is particularly true of solar heating systems. Early consideration of the solar system during building design will be an important factor in obtaining optimum performance from the system.

Architectural Consideration

The collector subsystem is designed to form an integral part of building structure and replace a portion of the normal roof structure. Therefore it is important that careful consideration be given to the aesthetics of the building-collector interface and the orientation and placement of the building on the building site. For the maximum solar collection, the collectors should face due south. Variation of $\pm 20^\circ$ will not have significant effect on total incident radiation, Ref. 1. The collectors should be tilted from the horizontal at an angle of the local latitude $+ 10$ to 15° for optimum heating efficiency. This angle may vary $\pm 10^\circ$ without significant degradation of performance, Ref. 1.

Shading of the collectors can cause a significant decrease in the incident radiation. Mapping of the "solar window" for the proposed site will assist the architect in determining that adjacent buildings, trees, etc., do not affect the amount of energy available to the collectors, Ref. 1.

Building Construction

The building construction should meet the HUD Minimum Property Standards (Ref. 1) and all applicable local codes. Placement of the subsystems should be optimized to reduce duct runs and piping requirements.

Walls and ceilings should be insulated to R19 and R30 values respectively. Windows should be of the insulating glass type or equipped with storm windows.

Auxiliary Energy

The solar energy system is generally designed to supply some percentage of the thermal energy requirements for a typical 24-hour period, at the winter design temperature.

The uncertainty of the availability of solar energy during inclement weather requires that 100% auxiliary energy be available to meet the building heating and hot water demands.

Auxiliary energy for this system can be supplied from fuel oil, gas, electric strip heaters, heat pump or a combination of the above, depending on local considerations. The size of the auxiliary energy subsystems should be calculated for 97 1/2% design temperature in accordance with ASHRAE procedures (Ref. 3).

Performance Summary

The system is designed to operate in any region of the United States except the extreme north and south. The following may be used as a guide for system application within the insolation and heating degree day ranges shown below.

Mean Daily Insolation (Typical Winter Mean) 625 to 1475 BTU/FT²

Yearly Heating Degree Days 2000 to 6500

The following information summarizes the general characteristics and design parameters for a typical center point design.

General

The solar heating and cooling system shall:

- a) be suitable for single family dwelling or small commercial application
- b) provide space and domestic hot water heating
- c) be of the direct air collector type
- d) utilize an electric furnace, heat pump or other forced air system as the source of auxiliary energy
- e) use collector pebble bed and air handler uniquely sized for the designated site of installation.

Design Parameters - Typical Application

Mean Daily Solar Insolation (Winter)	-	770 BTU/FT ²
Yearly Heating Degree Days	-	3300
Peak Heating Load @ 15°F	-	41,250 BTU/HR
Average Annual Heating Load	-	65 x 10 ⁶ BTU
% Total Load Supplied by Solar (Heating Season)	-	58%
Collector Area (effective)	-	591 ft ²
Pebble Bed Size	-	22 Tons of Pebbles (Approximately)
Air Flow (Collectors)	-	2.5 CFM/FT ²
Main Duct (Direct Mode-Collector to Load)	-	1500 CFM @ 1.8in.SPWC
Maximum Annual Requirement for Auxiliary Energy	-	31.8 x 10 ⁶ BTU
Domestic Hot Water Capacity	-	74 gallons
Minimum DHW Supply Temperature	-	140°F
Maximum DHW System Recovery Time	-	2.4 hours
DHW Minimum Delivery Rate	-	1.2 gal/min
Average DHW Heating Load	-	0.9 x 10 ⁶ BTU/MONTH
% DHW Load from Auxiliary Energy	-	57%
Maximum Electrical Power for Solar System Operation	-	1.0 KW
Maximum Electrical Power for Total System Operation (4-ton Heat Pump & 20 KW Strip Heaters)	-	28.0 KW
Maximum Average Annual Electrical Energy Consumption for Total System	-	6700 KWH

SUBSYSTEM'S DESCRIPTION **3**

The subsystems that are integrated into the solar heating and hot water system are:

1. Collector subsystem
2. Energy storage subsystem
3. Energy transport subsystem
4. Hot water subsystem
5. Control subsystem
6. Auxiliary energy subsystem
7. Integration subsystem

A summary of the characteristics of the subsystems is presented in Table 3-1 with a description of each subsystem in subsequent paragraphs.

Table 3-1. Subsystem Summary.

SUBSYSTEM	DESCRIPTION	MANUFACTURER/SUPPLIER
1. Collector	2' X 12' flat panel single glazing, air type manifold & feeder ducts	Solar Energy Products/EF-212 Constructed on site
2. Energy Storage	11'L x 10'H x 7'W high pebble bed with 3/4" x 1 1/2" washed river stone (Dimensions include air plenums top and bottom)	Constructed on site
3. Energy Transport	1) Centrifugal belt driven blower with built-in motor-controlled dampers. 2) 4 ea. back-draft dampers	Solar Control Corp./Series 20 American Warming & Ventilating Co./Mod SHB-P-1217 Corlastic
4. Hot Water	1) Air-to-water heat exchanger 2) 80 gal. pre-heat tank 3) Circulating pump 4) Conventional hot water heater	Halstead Mitchell/SW2-18-18-8 W. L. Jackson Mfg. Co./S0801 Grundfos/UP 25-42 SF Supplied by owner
5. Control	1) Energy transport control 2) Hot water differential thermostat 3) Interface Control Unit 4) Auxiliary Energy control	Solar Control Corp./75-176 Rho-Sigma/106 IBM 7933619 Supplied with Auxiliary Energy Subsystem
6. Auxiliary Energy*	1) Heat pump air-to-air 2) Resistance heaters	Supplied by owner (4-ton unit selected based on cooling load) Supplied by owner
7. Integration	Duct work, piping, insulation, valves and dampers	Constructed on site

*Although a heat pump with separate resistance heaters is shown, the Solar System is adaptable to any of the conventional energy systems such as gas, electric or fuel oil.

3-1 COLLECTOR SUBSYSTEM

The Solar Energy Products, Model EF-212, air heating solar collector is shown pictorially in Figure 3-1. The basic collector module is a 2 ft. by 12 ft. rectangular unit housed in an extended aluminum frame. The solar energy absorber is a corrugated, embossed aluminum sheet 0.016 inches in thickness. A one inch thick polyisocyanurate board forms the bottom of the module structure and serves as the back side thermal insulation of the collector. The module has a single glazing of 1/8" thick tempered safety glass (PPG HERCULITE[®]K) installed as two separate panes. The inlet air is introduced into the collector through a six inch port at the lower end of the module, passes between the corrugated absorber plate and the insulation, thence, through a six inch outlet port at the upper end of the collector. Collector modules are ganged to form a collector array as shown in Figure 3-2 .

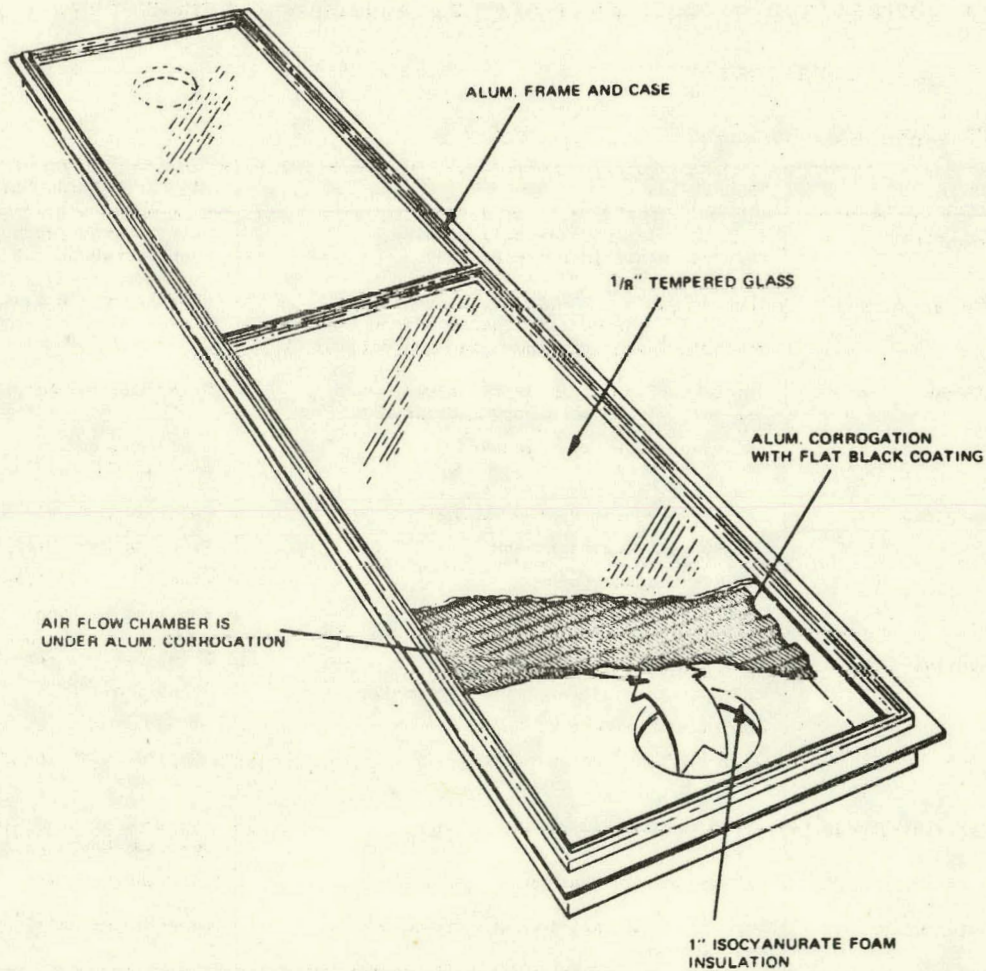

Figure 3-1. Solar Energy Products, Model EF-212 Collector (Air type)

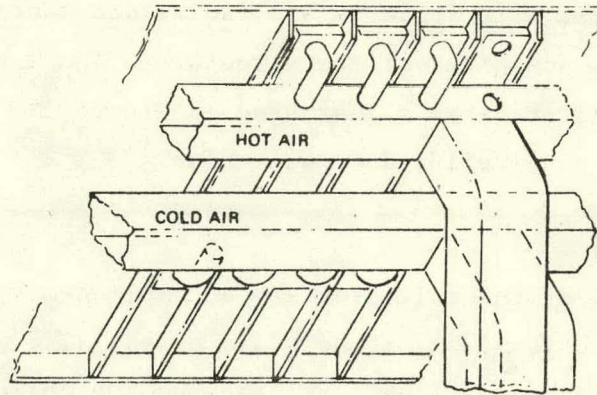

Figure 3-2. EF-212 Air Collector Interconnections.

The EF-212 collectors are suitable for integral roof (flush) mounting in new construction projects, such as System 1/A, retrofit roof mounting on properly designed support structures, or adjacent-to-structure mounting on suitable ground level support frames, where roof mounting is impractical. Tilt angle for the collectors for optimum year round performance should be the local latitude plus 10° but a variation of $\pm 15^{\circ}$ from the value results in only a 2% loss in performance. Due south orientation of the collectors is ideal but, again, a variation of 30° east or west causes only about 3% degradation in performance.

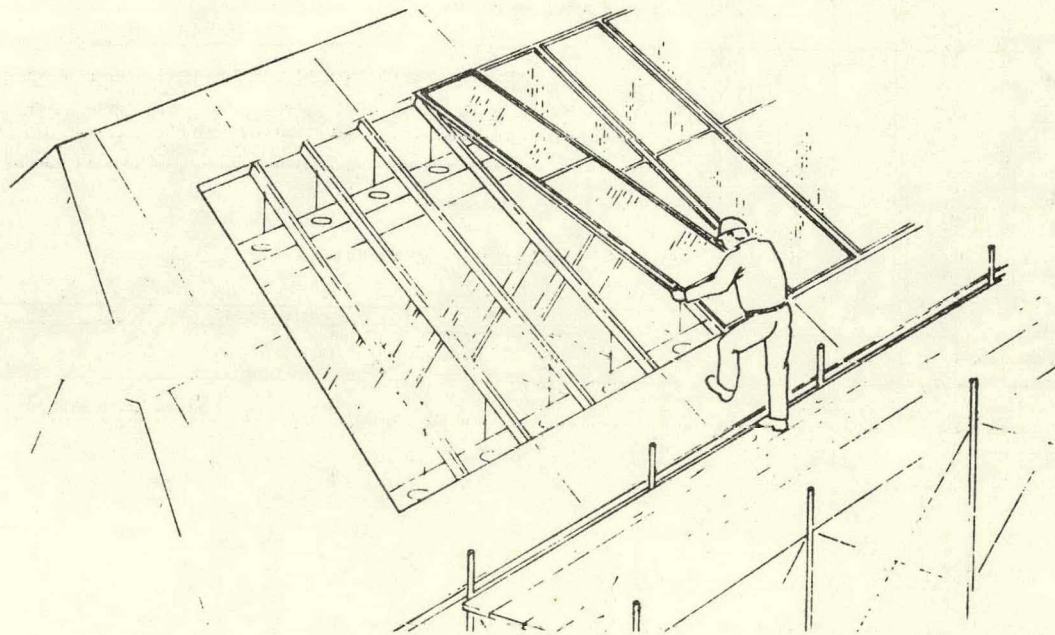

Figure 3-3. "Drop-in" Mounting.

In System 1/A the collector tilt angle is 45° facing due south, corresponding with the roof orientation and pitch of the structure. The integral roof or "drop-in" mounting configuration as illustrated in Figure 3-3 was selected for improved appearance and simplified construction.

Rain and moisture sealing of the collector are accomplished by rubber spline seals above and bedding compound below the glass panes. The method of attachment of these seals and detailed dimensional data on the collector module are presented in Figure 3-4 .

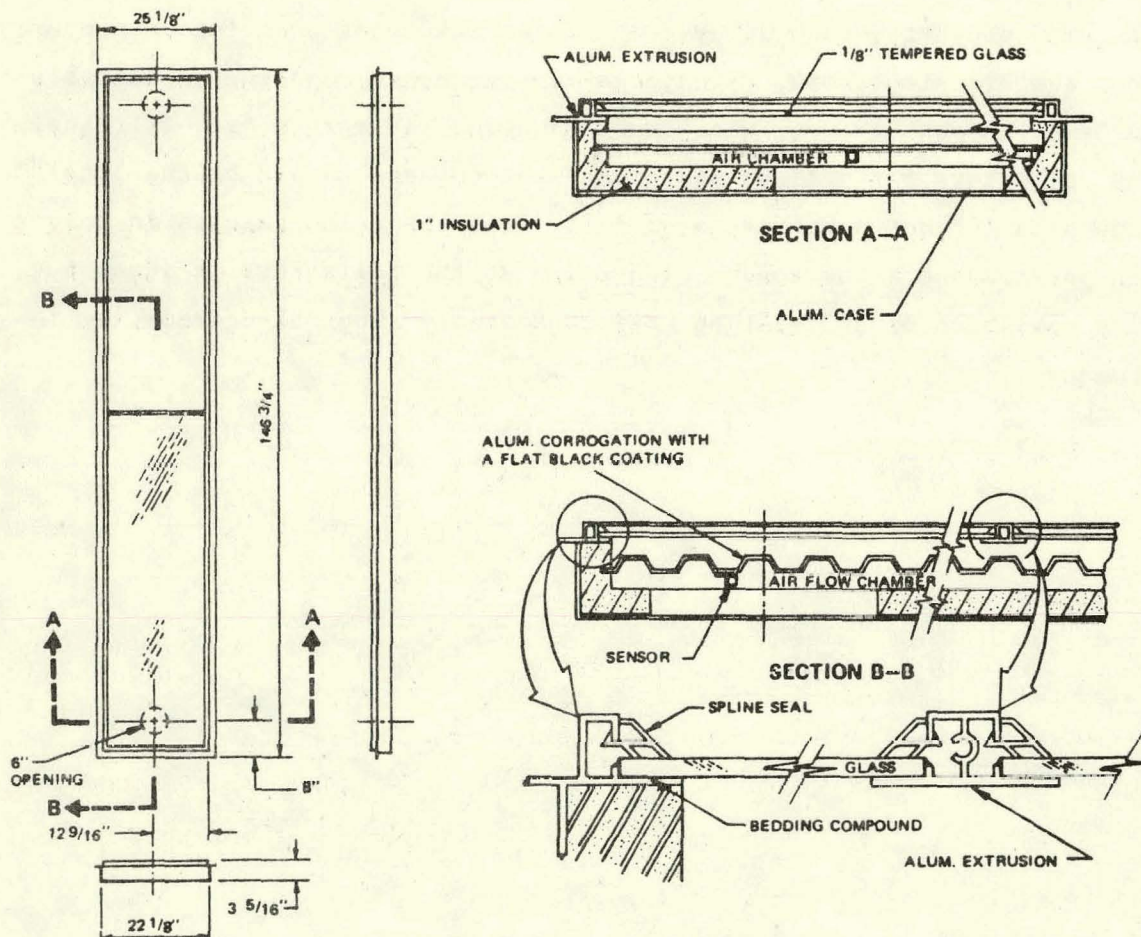

Figure 3-4. Details of EF-212 Collectors.

Collector Performance Data

The performance of the Solar Energy Products Model EF-212 collector in terms of collector efficiency, for any value of solar insolation, can be found from the curve of Figure 3-5 . The collector parameters used in plotting this curve are defined as follows:

- η = Collector efficiency
- T_{IN} = Collector inlet air temperature in $^{\circ}F$
- T_{AMB} = Ambient outside air temperature in $^{\circ}F$
- τ = Cover transmittance x absorptance of solar absorber
- F_R = Collector heat removal factor
- U_L = Collector heat loss factor
- W_c = Air flow rate through collector
- q = Solar insolation in $BTU/HR/FT^2$

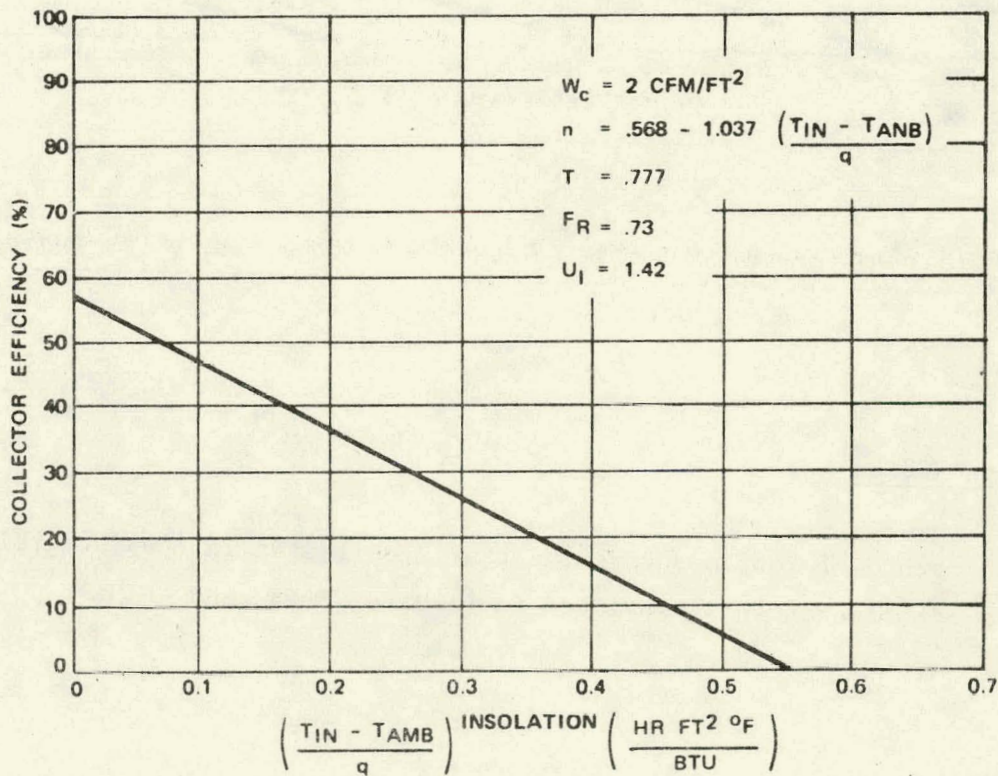

Figure 3-5. Performance of EF-212 Collectors for any value of Solar Insolation.

Figure 3-6 is a plot of collector heat output in BTU/HR versus ambient temperature, over the range of solar insolation values from 50 to 350 BTU/HR/FT², for a single EF-212 collector module. This plot was developed for a collector inlet air temperature of 70° and an air flow rate of 3.65 CFM per square foot of collector. This data is useful in determining the number of collector modules required to supply a given heat load, under specific conditions of outside temperature and solar energy input.

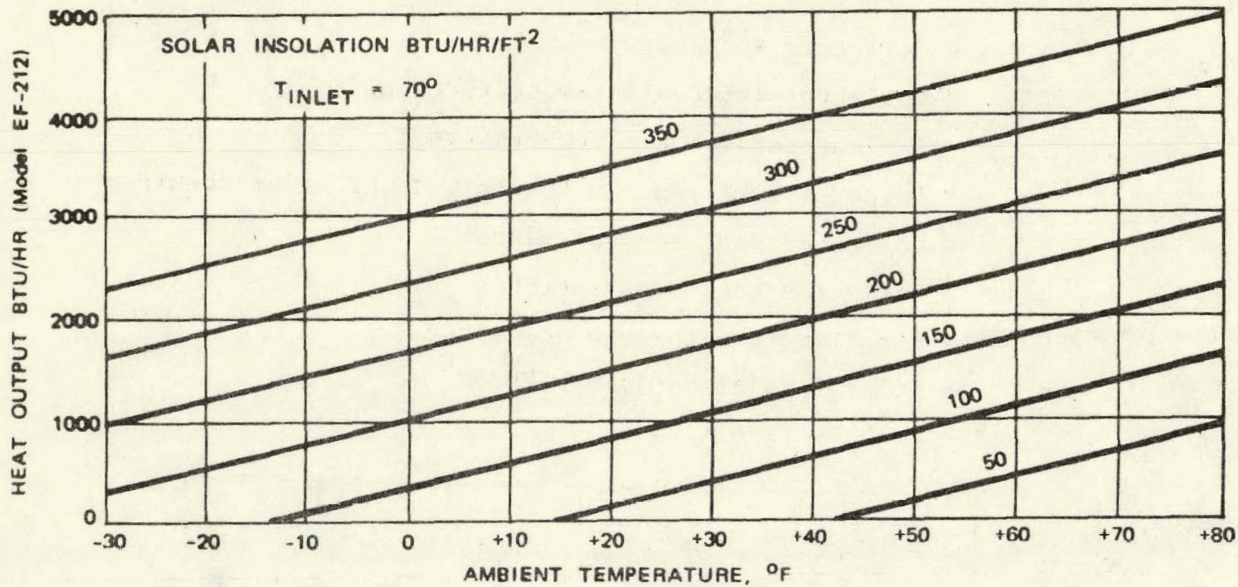

Figure 3-6. EF-212 Collector Heat Output vs Ambient Temperature for Various Values of Solar Insolation.

Installation Method

The general method of roof mounting the EF-212 collector in the integral roof or 'drop-in' configuration is depicted in Figures 3-7A and 3-7B.

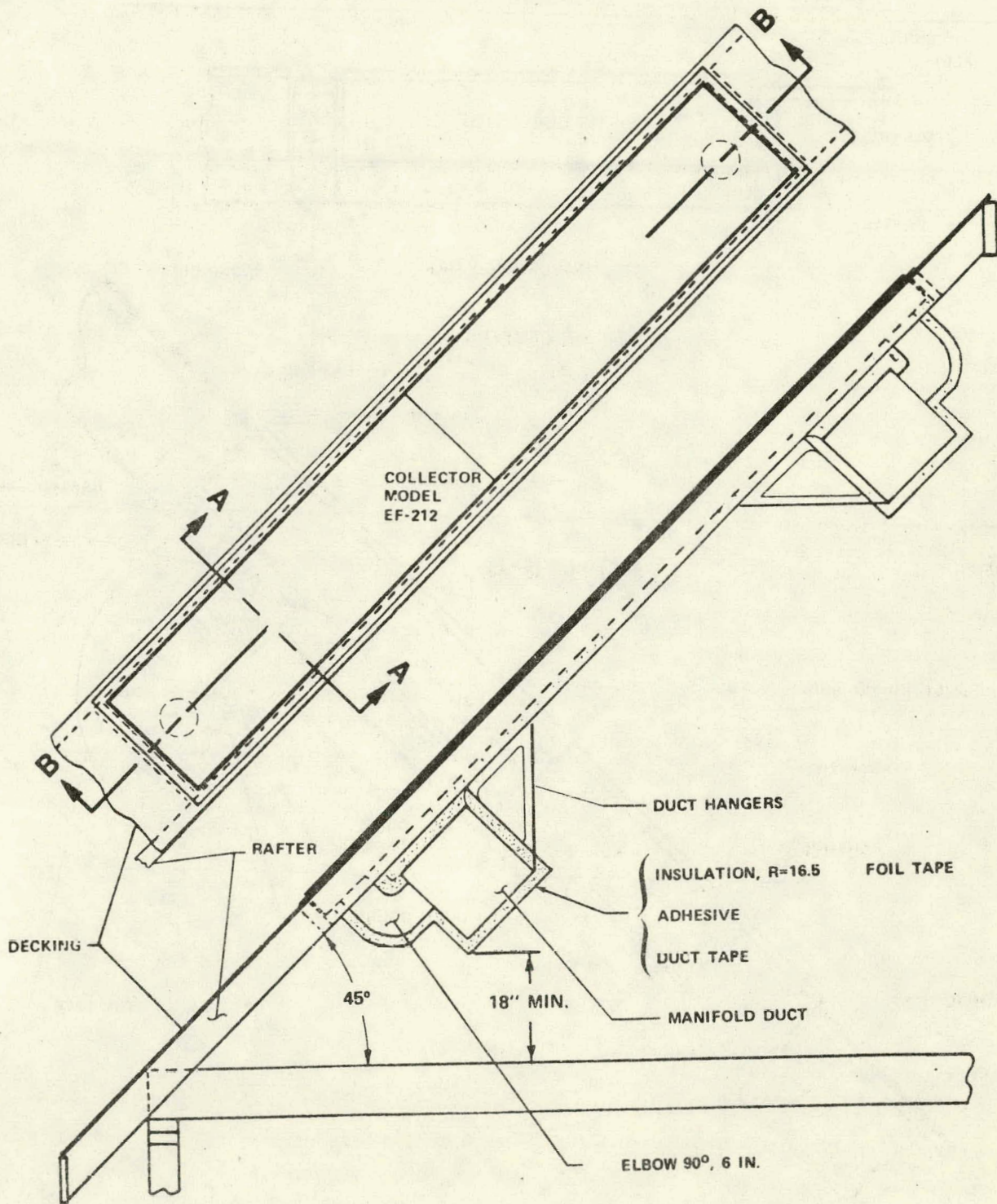

Figure 3-7A. Roof Mounting Details of EF-212 Collectors.

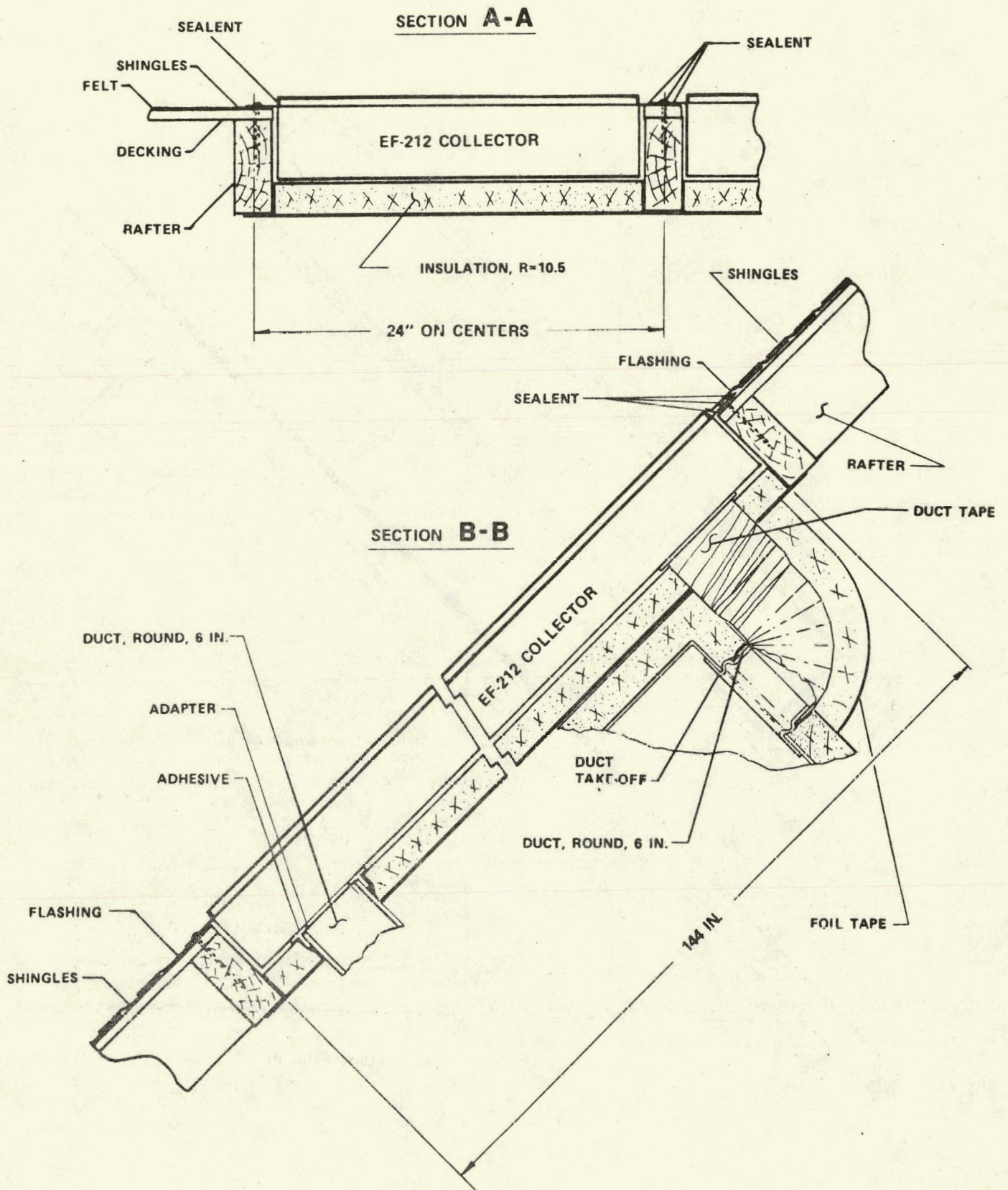

Figure 3-7B. Roof Mounting Details of EF-212 Collectors.

3-2 ENERGY STORAGE SUBSYSTEM

The energy storage unit provides a means of storing heat obtained from the collectors when not required to heat the building space. The stored heat can later be drawn from the storage unit and used to condition the building space when heat is not available from the collectors.

The bed consists of pebbles (river rock) of 3/4" to 1-1/2" in size in a suitable container. The rock should be washed to remove dirt that might be picked up by the air circulating through the pebble bed.

This heat storage unit can be of any shape to fit architectural considerations; however, it has been found that an approximate cubic shape offers the optimum configuration for construction, heat loss, and air flow pressure drop. Details of a typical pebble bed are shown in Figure 3-8.

The container can be constructed of any of the following:

- (a) plywood on a wood frame of 2 x 4s or 2 x 6s
- (b) concrete block or other masonry materials
- (c) poured concrete.

The heat storage unit should be insulated to a minimum of R-11. This could be roll, batts, boards, foam, or other suitable type insulating materials. The roll or batt type should be applied to the outside or between the structural members of the storage unit. If the insulation material is firm enough, it could be applied to the interior of the storage unit. The top of the unit must be insulated as well or better than the sides. Consideration should also be given to insulating the bottom of the bed if possible.

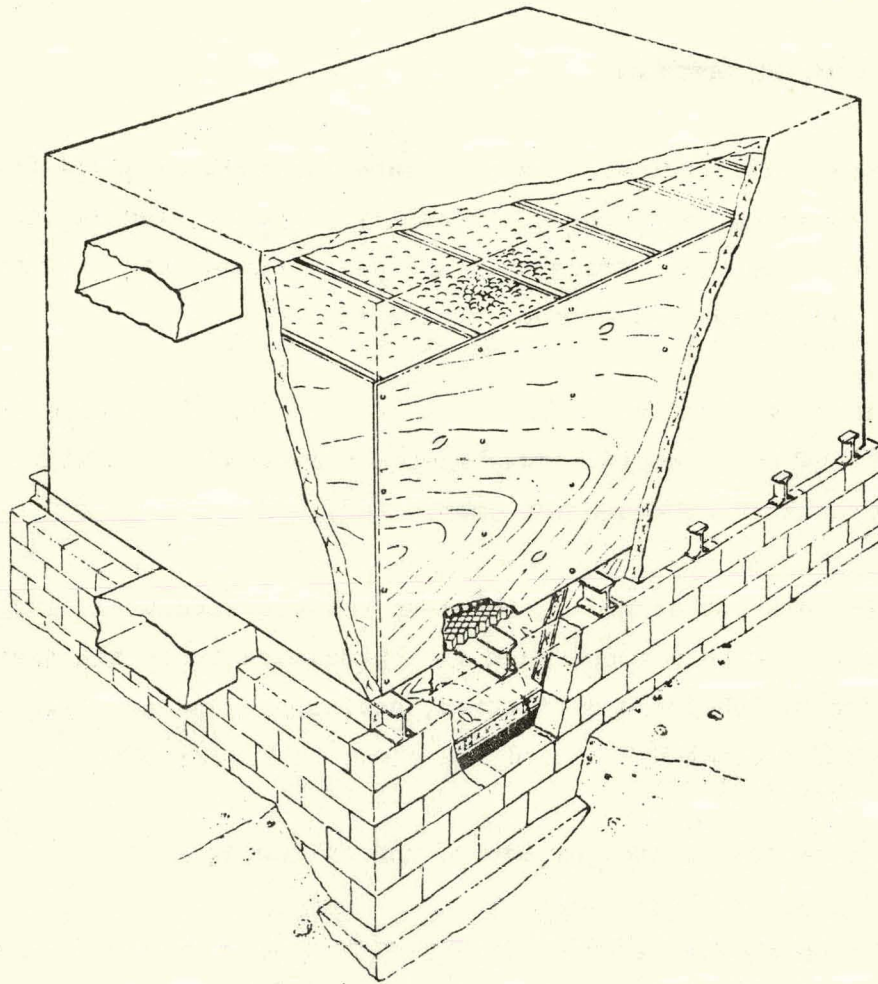

Figure 3-8. Typical Heat Storage Unit Construction.

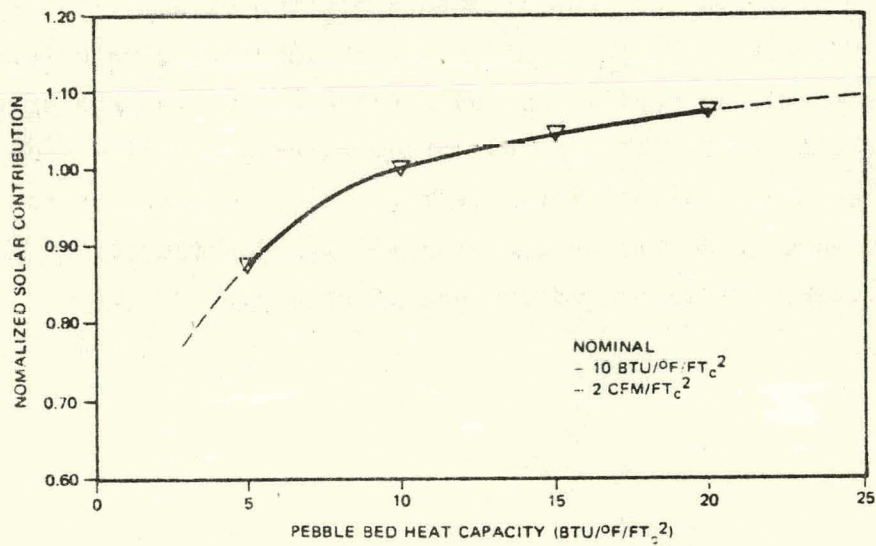

Figure 3-9. Pebble Bed Heat Storage Capacity.

Vertical air flow through the bed is most efficient with the hot air being supplied at the top while collecting and the cool air being removed from the bottom. Hot air would be removed from the top of storage to go to load. Horizontal air flow can be used, but more care must be taken to ensure even heat distribution in the storage unit.

A plenum is provided at the top and bottom of the storage unit to allow connection of the air circulation system and provide a means of distributing the air throughout the pebble bed.

The energy storage unit can be located in a basement, crawl space, below ground or within the living area. Due to the weight of the pebble bed, it should not be placed above ground without adequate structural support.

Typical pebble bed density for rocks $3/4'' \times 1-1/2''$ in size is approximately 100 pounds per cubic foot (lbs/Ft^3). Using a specific heat value of 0.2 for rock gives a heat storage capacity of $20 \text{ BTU}/\text{Ft}^3$ per $^{\circ}\text{F}$.

A heat storage capacity designed for the range of 10 to 20 $\text{BTU}/^{\circ}\text{F}$ for each square foot of collector area will provide the optimum size of the storage unit. Figure 3-9 shows the affect of pebble bed size (heat storage capacity) on overall thermal performance of the solar system. The solar fraction for each capacity is normalized to the value for a capacity of $10 \text{ BTU}/^{\circ}\text{F}/\text{Ft}^2$. The graph shows that reducing the storage size by half (to $5 \text{ BTU}/^{\circ}\text{F}/\text{Ft}^2$) reduces the heat storage for the system to a value of .9 or a reduction of 10%. Increasing the storage size by 100% to $20 \text{ BTU}/^{\circ}\text{F}/\text{Ft}^2$ increases the heat capacity to a value of 1.08 or only 8% increase. In other words, building a larger storage unit does not provide proportionately more heat storage capability.

The range of 10 to 20 BTU/°F/Ft² represents approximately 50 to 100 pounds of rock per square foot of collector and 1/2 to 1 cubic foot of storage volume.

An additional consideration in sizing the energy storage unit is the depth and area of the unit in order to obtain a sufficient static pressure drop through the pebble bed to ensure that the air, as it circulates through the bed, will distribute evenly across the unit. The minimum recommended pressure drop is 0.15" water gauge. This pressure drop, or resistance to air flow, helps keep the hot air from 'channeling' through the pebble bed. Oversizing the storage unit reduces the resistance to air flow and makes it difficult to obtain the optimum pressure drop. The maximum pressure drop is limited by the capacity of the air circulation system.

In some cases, a device to help diffuse the air may be necessary. This can take the form of a transition fitting to increase the air duct size, where it connects to the supply plenum, to reduce the velocity of the air as it enters the bed.

3-3 ENERGY TRANSPORT SUBSYSTEM

The Solar Control Corporation Series 20 Air Handler is shown pictorially in Figure 3-10 . The metal cabinet, 42" L X 42" H X 27" W contains a centrifugal belt driven blower, a 1/4 to 1 HP, 115V, low noise, high temperature motor and motorized dampers. Operation of the blower and dampers to route the air flow for the various modes of system operation is achieved through the control subsystem. A part of the control subsystem is packaged in the Air Handler.

THE MOTOR SIZE AND BLOWER SPEED ARE DETERMINED BY THE MAX. LOAD DEMANDS OF THE SYSTEM. (MOTORS ARE SPECIFIED IN TABLE "A".)
ALL 115 VAC WIRING IS TO BE UL LISTED.

TABLE "A"

H P.	MANUFACTURE	STYLE NO.	FRAME TYPE
1/4	WESTINGHOUSE ELECTRIC CORP.	317P002	FH-SC56
1/3	WESTINGHOUSE ELECTRIC CORP.	317P003	FH-SP56
1/2	WESTINGHOUSE ELECTRIC CORP.	317P004	FH-56
3/4	WESTINGHOUSE ELECTRIC CORP.	312P629	FH-B56
1	WESTINGHOUSE ELECTRIC CORP.	311P297	FH-F56

DAMPER MOTORS WILL BE:
DAYTON No. 3M231 WITH MAGNETIC TYPE BRAKE REMOVED.
7 RPM, 1/100 H. P.
0.66 FLA. IMPEDANCE PROTECTED
115 VAC/60 CYCLES, CLOCK-WISE ROTATION (SHAFT END)

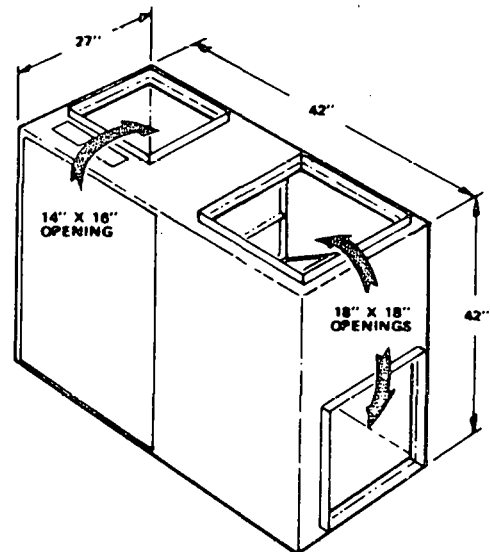

Figure 3-10. Solar Air Handler.

The back draft dampers, American Warming & Ventilating Co. SHB-P-1217 are located in the interconnecting duct work. These dampers are constructed of corlastic material and are 18" L X 18" H X 3-1/2 W.

Cabinet, blower, and motor sizes and speed must be selected to ensure adequate air handling capacity to satisfy the collector, energy storage, and building design conditions.

Installation must be done in such a manner that no unplanned restrictions affect the designed static pressure or air volume.

3-4 DOMESTIC HOT WATER SUBSYSTEM

Hot water for domestic use is provided in the solar system by means of an air-to-water heat exchanger in the air duct from the collector and a water storage tank to preheat the water supplied to the conventional building water heater. A small pump circulates water from the preheat tank through the heat exchanger coil. (See Figure 3-11). The hot air from the collector heats the water in the coil and it is collected in the preheat tank. The conventional water heater draws its supply from the preheat tank and auxiliary energy is used only if the temperature of the preheat tank drops below the water heater set point. Cold city water is drawn into the preheat tank. The control subsystem turns the circulating pump on when the collector is delivering air of sufficient temperature to provide heat to the preheat storage tank.

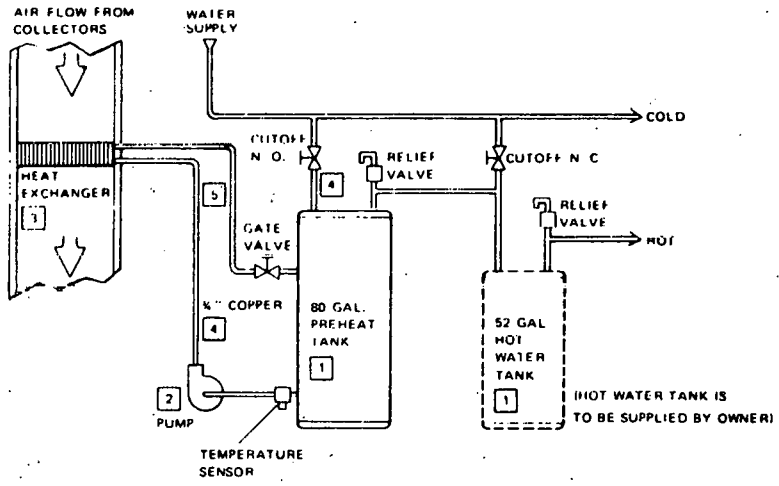

- NOTES
- 1 ALL TANK CONNECTIONS ARE 1/2" MPT.
 - 2 PUMP CONNECTIONS ARE 1.0" IPT, ELECTRICAL SERVICE FROM INTERFACE CONTROLLER BOX
 - 3 HEAT EXCHANGER CONNECTIONS ARE 1.0" MPT
 - 4 ALL PIPING IS 1/2" COPPER TUBING OR EQUIVALENT, INSULATED WITH A MIN. R VALUE OF 5.0 ON HOT WATER LINES
 - 5 PIPING IN CIRCULATION LOOP CAN NOT EXCEED 50' OF 1/2" COPPER TUBING OR EQUIVALENT
 - 6 FLANGE ISOLATION VALVES ARE USED ON INPUT & OUTPUT FROM PUMP

Figure 3-11. Domestic Hot Water Subsystem.

Components of the hot water system for System 1A are:

- The Halstead and Mitchell, SW2-18-18-8, air-to-water heat exchanger - has a two row 5/8" O.D. tube constructed to fit into an 18" x 18" duct
- The W. L. Jackson, S08D1, preheat tank - has an 80-gallon capacity and is 24" in diameter and 73-7/8" in height, including a 2" fiber-glass insulation blanket
- The circulating pump, Grundfos/UP 25-42 SF,- is constructed of stainless steel with water lubricated bearings driven by a 1/20 hp, 110V ac motor.

3-5 CONTROL SUBSYSTEM

The control subsystem provides for sequencing and control of the solar subsystems and heat pump auxiliary to establish operating modes suitable for all conditions of season and solar energy input. The functional units comprising the control system are: (1) Solar Control Corporation Model 75-176 controller (IBM P/N 7933624), (2) Rho-Sigma Model 106 differential thermostat, (3) the conventional control circuit supplied with the heat pump, and (4) an interface control unit, which is a unique design for this system, to interface with the GE Model WA848R1A/WE 948 C heat pump.

The solar controller (7933624) processes three temperature sensor inputs to place the energy transport subsystem in one of five (5) modes of operation. The operational modes, which are discussed in detail in Section IV, System Operation, are:

Mode 1 - Collector-to-Room Heating

Mode 2 - Storage-to-Room Heating

Mode 3 - Heat Pump-to-Room Heating

Mode 4 - Collector-to-Storage

Mode 5 - Summer Operation

The solar controller is used to start and terminate collector operation in the heating season. Turn-on of the collector loop occurs when the differential temperature between the collector outlet and the bottom of the pebble bed is 45°F, nominal. Collector flow is terminated when this value of differential temperature is 28°F, nominal.

The Rho-Sigma differential thermostat provides control of the Domestic Hot Water (DHW) system. Transfer of heat from the collector loop to the DHW loop starts when the differential temperature between the collector outlet and the preheat tank is 20°F, nominal and terminates when this differential falls to 3°F.

The interface control unit provides the electrical isolation, routing and sequencing required to coordinate control of the heat pump with the solar subsystems. The unit is designed for construction by the site electrical contractor using conventional HVAC components and fabrication techniques.

Table 3-2 is a summary of the system conditions and parameters as a function of control mode.

Table 3-2. Summary of System Conditions/Parameters.

	BLDG. HEAT REQD.	SOLAR ENERGY AVAIL.	STORAGE TEMP GREATER THAN 90°F	DHW TEMP. LESS THAN DIFFERENCE	DHW PUMP	MODE
Interface	Yes	Yes	-	No	Off	1
Control Box	Yes	Yes	-	Yes	On	1
Select	Yes	No	Yes	-	-	2
Switch in	Yes	No	No	-	-	3
"Solar"	No	Yes	-	No	Off	4
Position	No	Yes	-	Yes	On	4
Select	No	Yes	-	No	Off	System Off
Switch in	No	Yes	-	Yes	On	5
"Heat Pump"	No	Yes*	-	-	-	5
Position						

*Collector temperature is greater than maximum allowable.

- Don't care condition

Figure 3-12 is a typical control schematic of a control subsystem interface with auxiliary energy subsystem and the solar controller.

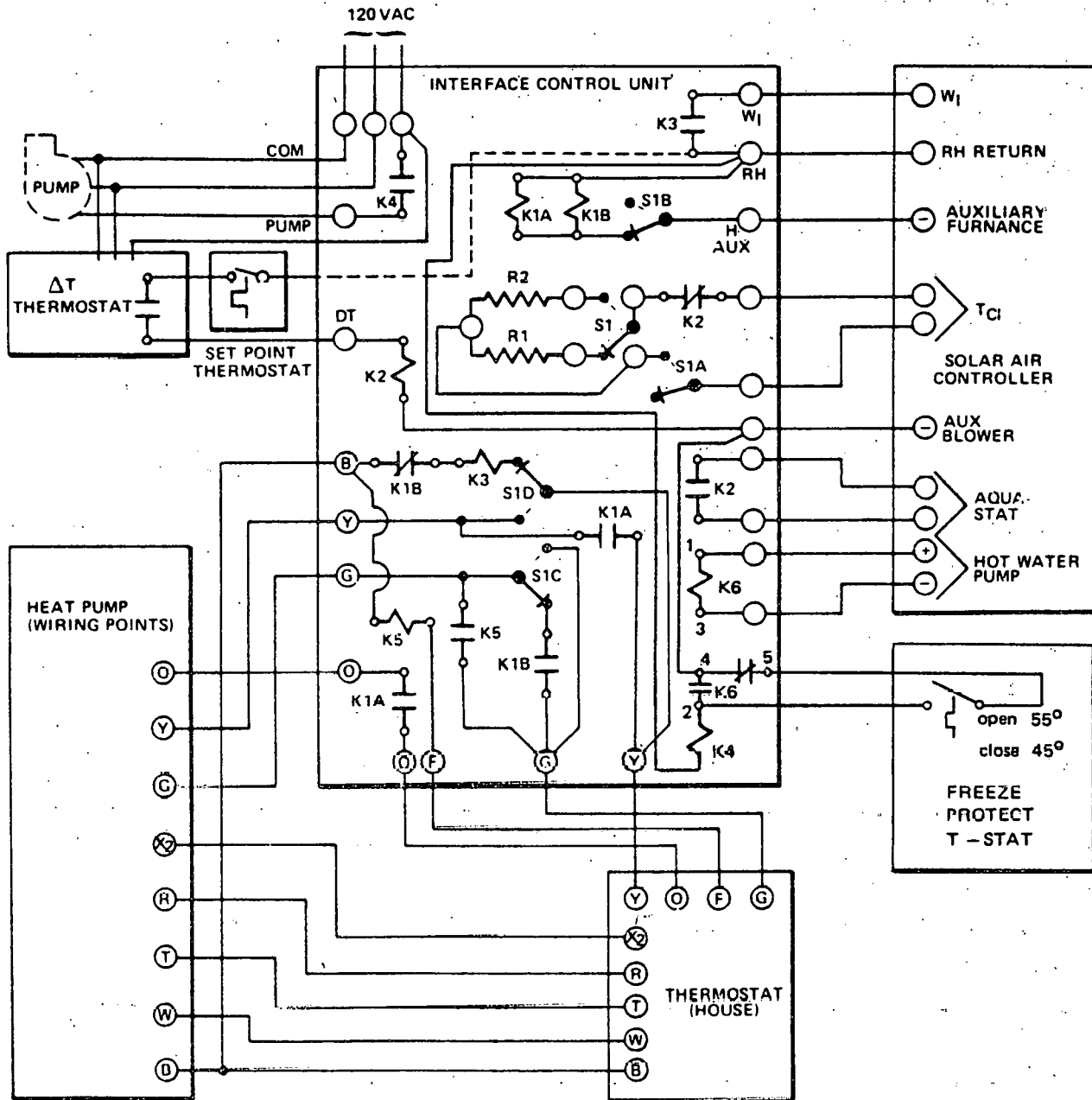

Figure 3-12. Typical Control Schematic.

Installation

The control subsystem components are typically mounted in the mechanical equipment room near the air handling unit. Interconnecting field wiring is shown in Figure 3-13 .

Control subsystem temperature sensor installation requirements are shown in Figure 3-14 . Sensor wires may be 18 gauge twisted pairs for runs up to 200 feet. The two collector sensors must be mounted (with good thermal conductivity) to the absorber plate near the collector outlet. The DHW pre-heat tank sensor mounts in a standard 1/2" NPT port.

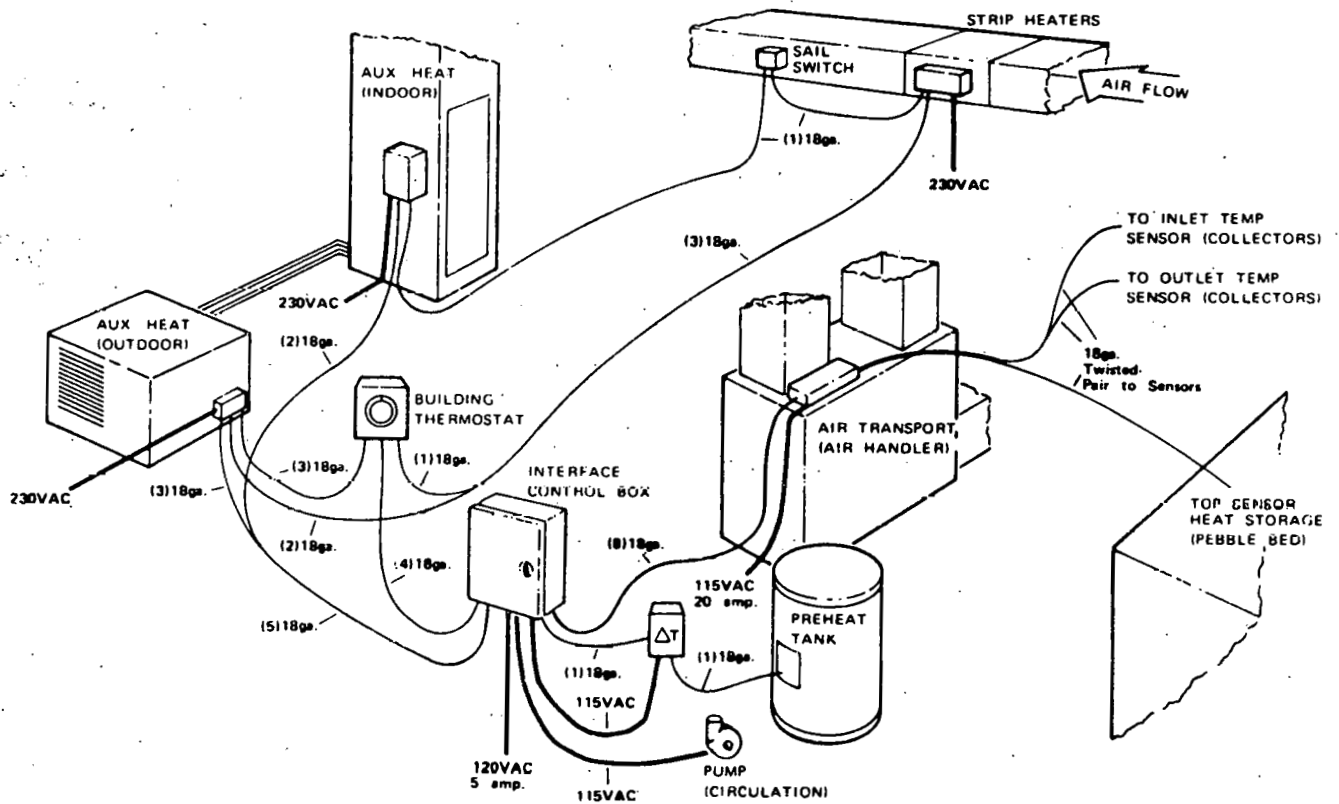
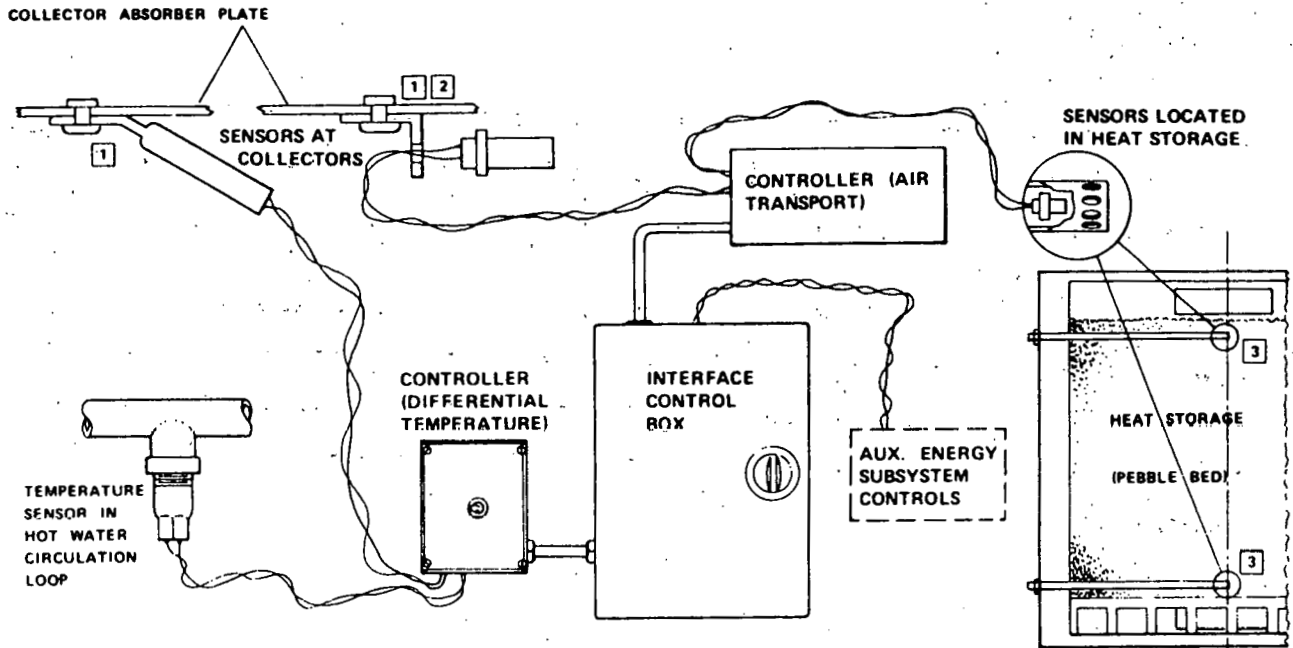

Figure 3-13. Interconnecting Field Wiring for System 1A.



THE FUNCTIONAL UNITS ARE:

CONTROLLER (AIR TRANSPORT)	SOLAR CONTROL CORP. ZIA MODEL 75-176
CONTROLLER (DIFFERENTIAL TEMPERATURE)	RHO SIGMA MODEL- 106
INTERFACE CONTROL BOX	IBM 7933619

NOTES.

- 1 COLLECTOR SENSORS MOUNTED FOR GOOD THERMAL CONTACT AND MAXIMUM EXPOSURE TO AIR FLOW AT EXIT DUCT
- 2 SENSOR MOUNTING BRACKET NOT TO EXCEED $\frac{1}{16}$ " THICK X 1" LEGS
- 3 TYPICAL ACCESS TO CENTER-LINE OF STORAGE IS AT A LEVEL 6" FROM TOP OF ROCK AND 6" FROM BOTTOM WITH CONDUIT OF $\frac{3}{4}$ " I.D. MINIMUM

Figure 3-14. Control Subsystem and Temperature Sensors.

3-6 AUXILIARY ENERGY SUBSYSTEM

Since there are days when the solar energy will not be adequate to heat the building, an auxiliary system is required, designed to provide the entire heating requirements of the building.

The auxiliary heating can be supplied by heat pump, electric strip heaters, and gas or oil fired furnaces. Selection should be based on local requirements and availability of equipment. Sizing of capacity would be according to conventional building heat load calculations and code requirements.

For illustration, an air-to-air heat pump with separate outdoor and indoor units and separate auxiliary electric resistance heaters is discussed. The selection of a heat pump has several advantages:

- Higher coefficient of performance (COP) than electric heaters by themselves.
- A completely independent system in the event the solar system is unable to function.
- Cooling can be provided in the summertime.

For System 1 the heat pump auxiliary energy system is not supplied by the Government but is owner-selected and applied.

3-7 INTEGRATION SUBSYSTEM

In addition to the major subsystems discussed previously, close attention must be paid to the design, fabrication and installation of the ductwork and dampers which constitute the solar air distribution system. The best available components, interconnected by a poor duct system, will provide less than optimum performance. Performance of a solar heating system is highly dependent on proper integration of the various subsystems into a functioning system.

It is important to be familiar with the reference materials listed in Section 5 of this document. Particular emphasis should be placed on the HUD Intermediate Minimum Property Standards for Solar Heating and Domestic Hot Water Systems and the NASA Interim Performance Criteria for Commercial Solar Heating and Combined Heating/Cooling Systems and Facilities. It is assumed that the contractor is already familiar with the manuals published by the National Environmental Systems Contractors Association (NESCA) and the American Society of Heating Refrigeration and Air Conditioning Engineers (ASHRAE).

The building space distribution system is of equal importance to the overall success of the solar heating system and should not be overlooked. ASHRAE and NESCA manuals define the requirements for adequate distribution systems. The ducts shall be fabricated of suitable materials and properly installed. The system must have the lowest possible resistance to air flow, commensurate with the type of system installed and the volume of air circulated. Care should be taken that the system operate at a minimum noise level.

The volume of air circulated in a solar air heating system is not large; usually about 2 CFM per square foot of collector. For an average installation of 600 square feet of collector, the air flow rate will be 1200-1500 CFM. A typical duct size for this flow is 12" x 12". The actual air flow required will vary somewhat with the specific installation. The necessary duct sizing information is given in the NESCA and ASHRAE manuals. Undue ductwork restrictions should be avoided and ducts installed for minimum air leakage, in accordance with the best trade and code practices.

Damper operation is extremely critical for the operation of a solar air system. Dampers must operate freely, in accordance with the prescribed control sequence and must seal off tightly. Manual dampers are provided for change over from summer to winter operation. This allows operation of the domestic hot water pre-heat system while bypassing the pebble bed heat storage unit. An additional benefit of the manual damper is the provision for venting the attic space but adequate filtering for this vent is required.

Adequate insulation of the air distribution duct work is essential to conserve the heat developed by the collectors. Collected heat must be effectively transferred to the storage unit during winter operation but must not create an additional heat load in the occupied space during the summer months. Analysis shows that the duct insulation should have a minimum R value of 16.5 which is equivalent to not less than 5 1/2" of fiberglass insulation. Although this is more insulation than has been conventionally applied, its use is justified by analysis of the temperatures involved and the anticipated inflation of utility costs over the projected life of the installation.

The insulation must be installed in accordance with the best trade practices. The manual dampers provided for seasonal control and attic venting should be equipped with insulated panels to prevent excessive heat loss during winter operation.

Piping materials, installation and insulation for the domestic hot water system, between the pre-heat storage tank and the heat exchanger, should be in accordance with accepted practices, per the referenced manuals. Materials used must be adequate to withstand the highest anticipated temperature. Piping must be adequately supported to prevent sagging and vibration. Insulation shall be a minimum of R5.

Placement of the domestic hot water heater and auxiliary energy system heat exchangers in the system will be similar to that shown in the system schematic diagram, Figure 1-2. It is good installation practice to mount the heat ex-

changes in the duct so that they can be removed for repair, without dismantling the duct work. Flanges with bolts are recommended. Any changes in duct size to accommodate the heat exchangers should shall be accomplished with properly designed transitions. (See the NESCA manuals for typical examples.)

SYSTEM OPERATION 4

System No. 1 provides modes of operation which supply solar heated air either directly from the collectors or from the pebble bed storage into the house air distribution system. When solar energy is insufficient to supply the space heating needs, a full capacity heat pump will supply the house heating demand. The house heating load will be supplied either entirely from solar or entirely from auxiliary energy; hence, there will never be simultaneous operation of the two systems during the heating season.

Domestic hot water pre-heating is accomplished by an air-to-liquid finned coil heat exchanger in the solar supply duct. Year-round hot water is provided since the house air distribution in the cooling season is independent of the solar system. A full capacity auxiliary hot water tank is provided to supply the hot water demand at the selected output temperature. The pre-heat tank will supply water at a preselected maximum temperature (140°F). The conventional hot water tank will "top off" the pre-heated inlet water to the required delivery temperature.

The system flow diagram, Figure 4-1, shows the air flow control dampers with an accompanying damper schedule. Control damper and fan status is given for each of the five following modes of operation:

- Mode 1 - Collector-to-Load
- Mode 2 - Storage-to-Load
- Mode 3 - Heat Pump-to-Load
- Mode 4 - Collector-to-Storage
- Mode 5 - Summer Operation

Primary control is experienced by two sets of ganged double dampers internal to the Air Handler Unit (dampers D1 and D2, Figure 4-1). Each double damper is physically two individual blade dampers, mechanically coupled to be operated by one motor and control input. Dampers are ganged such that when damper A of a set is open, damper B will be closed. Conversely, if damper B is open, damper A will be closed.

DAMPER SCHEDULE

MODE	D1		D2		MD		FANS	
	A	B	A	B	1	2	F1	F2
COLLECTOR-TO-LOAD	O	C	O	C	O	C	ON	OFF
STORAGE-TO-LOAD	C	O	O	C	O	C	ON	OFF
AUX. HEAT-TO-LOAD	O	C	O	C	O	C	OFF	ON
COLLECTOR-TO-STORAGE	O	C	O	C	O	C	ON	OFF
SUMMER OPERATION	O	C	O	C	O	C	ON	ON*

O = OPEN ; C = CLOSED ; ON* = HOUSE COOLING

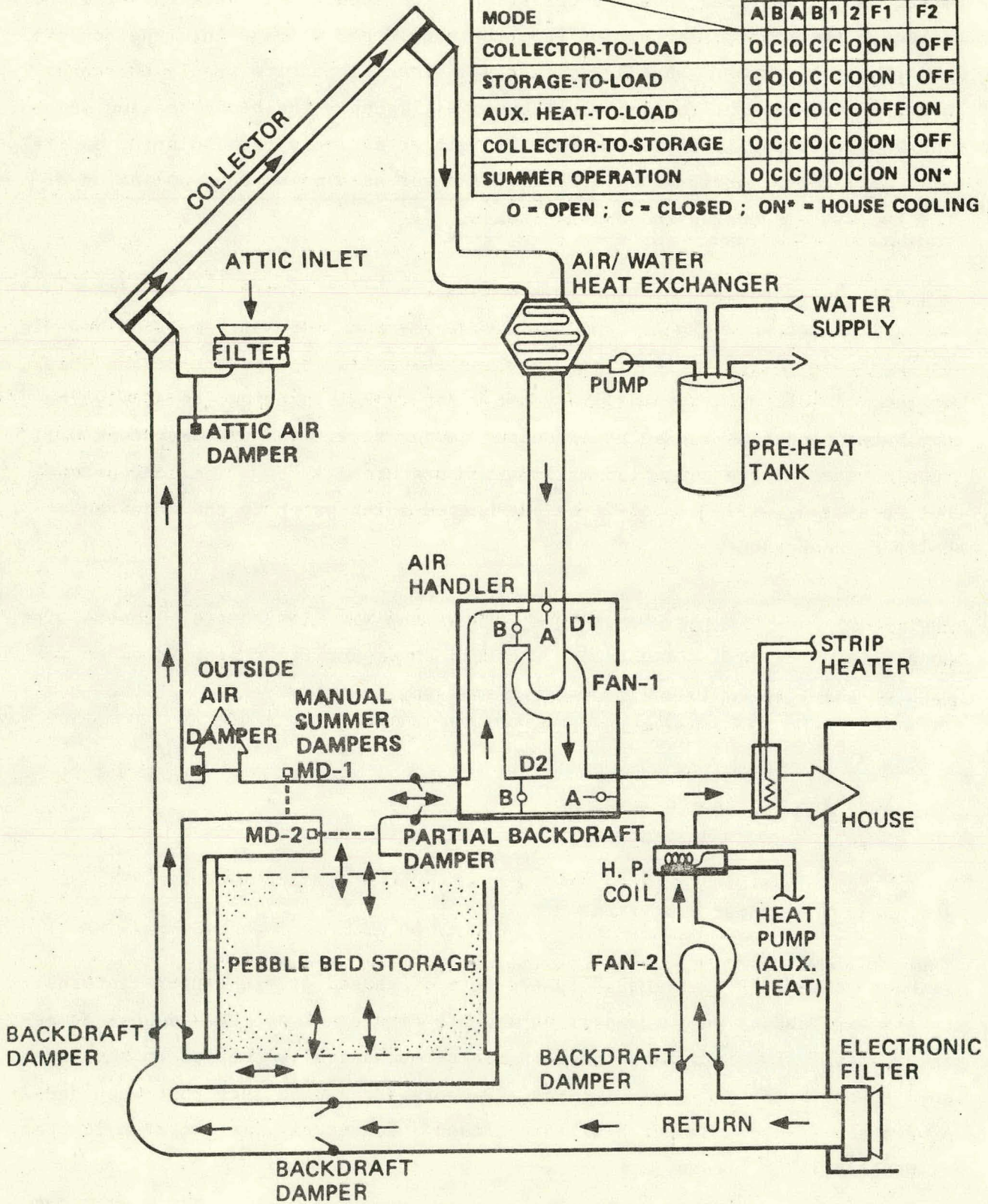

Figure 4-1. System Flow Diagram.

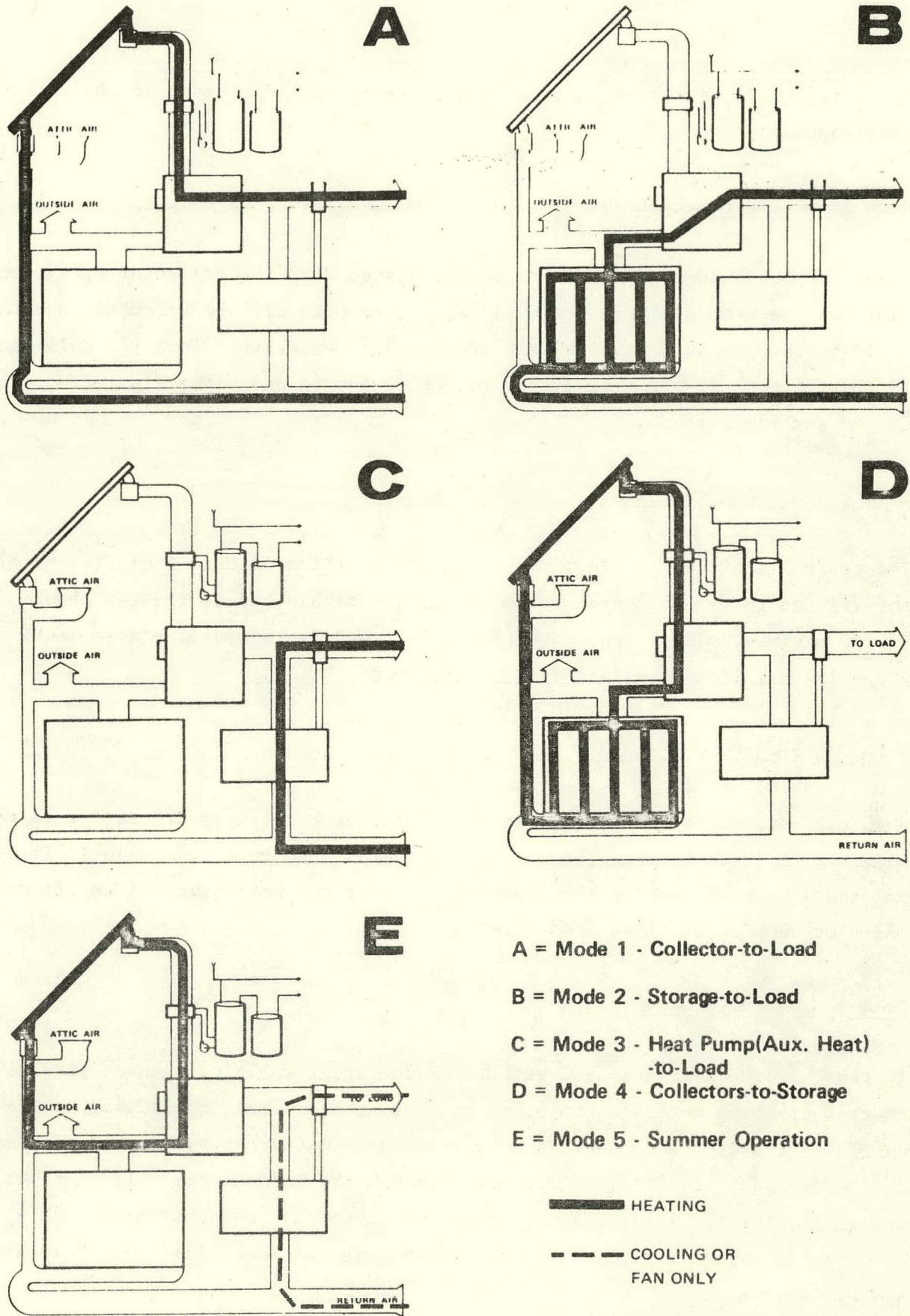

Figure 4-2. Modes of Operation.

Operating modes, in order of selection priority, are discussed in the following paragraphs:

Mode 1 - Collector-to-Load

Figure 4-2A depicts the air flow in the system when the collector subsystem provides the heated air to the building. This mode will be selected when the building thermostat calls for heat and the air temperature from the collector is greater than $T_{(out)}$ minimum and the collector is on. (See Figure 4-1 for damper and fan status.)

Mode 2 - Storage-to-Load

The control logic will select this mode of operation if Mode 1 conditions are not met and the temperature in the top of the pebble bed is greater than $T_{(out)}$ minimum. (See Figure 4-1 for damper and fan status.) Figure 4-2B shows the air flow path in this operating mode.

Mode 3 - Heat Pump-to-Load

When the conditions for Mode 1 and Mode 2 cannot be met, space heating is provided by the heat pump as shown in Figure 4-2C. In this mode, Fan F2 is on and the source of heat is the condenser coil of the heat pump. (See Figure 4-1 for damper and fan status.)

Mode 4 - Collector-to-Storage

If the building does not require heat or the solar collector cannot provide heated air above the $T_{(out)}$ minimum but is, nevertheless, collecting usable energy, the system will operate in a collector-to-storage mode, as indicated in Figure 4-2D. If the differential temperature between the collector outlet and the bottom of the pebble bed is greater than $\Delta T_{(on)}$ (approximately 30°F) the control logic will place the system in Mode 4. (See Figure 4-1 for damper and fan status.)

Mode 5 - Summer Operation

During summer or warm weather operation when space heating is not required, the system will operate in Mode 5, with flow paths as shown in Figure 4-2E. The building air distribution is handled by Fan F2 (heat pump) in either a "Cooling" or "Fan Only" mode. In this mode the solar collection loop will be used for hot water pre-heating only. This mode calls for operation of manual dampers MD1 and MD2 which are moved to positions shown in the Damper Schedule, Figure 4-1, to provide bypassing of storage.

An option exists whereby the attic and outside air dampers may be opened to provide ventilation of the attic space.

**THIS PAGE
WAS INTENTIONALLY
LEFT BLANK**

SYSTEM SIZING 5

The primary system parameters which determine the overall performance of the System I design at any given site are the collector area and the pebble bed size. A simplified procedure has been developed which allows the values of these parameters to be selected for the desired contribution from the solar energy system in meeting the total heating and hot water load. This procedure is presented in the National Bureau of Standards document NBS 76-1059, "Intermediate Minimum Property Standards for Solar Heating and Domestic Hot Water Systems", April 1976. The procedure is included herein, with modifications made only as they relate to applying the procedure to the specific System I design. An example case to illustrate application is also included.

System I is a solar heating system that utilizes air as the energy transport medium and is shown in Figure 5-1.

SYSTEM 1 IS A SOLAR HEATING & HOT WATER SYSTEM USING AIR COLLECTORS & ROCK STORAGE WITH AN AIR-TO-WATER HEAT EXCHANGER FOR WATER HEATING.

THE SYSTEM IS COMPRISED OF SEVEN OPERATIONAL SUBSYSTEMS:

COLLECTOR SUBSYSTEM	P/N 7933609
ENERGY STORAGE SUBSYSTEM	P/N 7933610
ENERGY TRANSPORT SUBSYSTEM	P/N 7933611
HOT WATER SUBSYSTEM	P/N 7933612
CONTROL SUBSYSTEM	P/N 7933613
AUXILIARY ENERGY SUBSYSTEM	P/N 7933614
INTEGRATION SUBSYSTEM	P/N 7933615
DATA COLLECTION SUBSYSTEM (NOT SHOWN)	P/N 7933616

SYSTEM PERFORMANCE IS DELINEATED IN THE PERFORMANCE SPECIFICATION, P/N 7933444, WHICH INCLUDES THE INSTALLATION DRAWINGS, P/N 7933617.

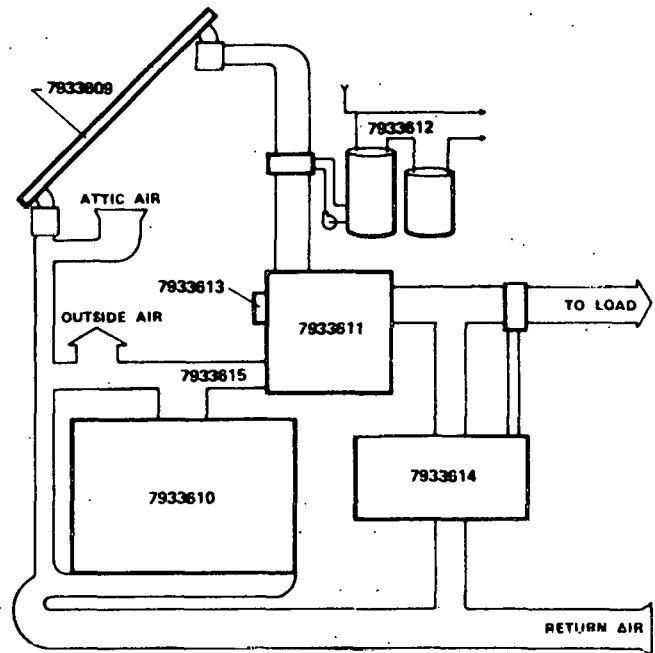

Figure 5-1. Basic Diagram of System 1A.

In addition to the air-cooled collector, an air system generally makes use of a pebble bed thermal storage device.

By use of the thermostatically controlled dampers, four basic modes of operation are possible: direct space heating from the collector, space heating from the pebble bed storage unit, charging of the pebble bed storage unit from the collector, and space heating using the auxiliary energy source.

General

- a. The following procedure allows the estimation of long-term solar heating system performance applicable for combined space heating and domestic hot water systems. The system evaluation procedure is not intended to provide an accurate prediction of system performance for any particular month, but rather for the long-term average.
- b. The following assumptions were made in developing the procedure:
 1. Thermal storage is contained within the heated structure and all storage heat losses are considered to supplement the space heating load.
 2. Auxiliary heat sources are provided to supply energy for both the space and water heating when the energy in storage is depleted. The auxiliary energy source is connected such that it does not heat the thermal storage unit directly. The rate of use of auxiliary energy is such that it provides just enough energy to supplement the solar heating system in meeting the heating load.
 3. The heat transfer fluid (air) is circulated through the collector whenever a positive energy gain can be achieved. During periods of low radiation (when the energy gain becomes zero or negative), the collector pump or blower is turned off.
 4. For the space heating load determination it was found that an energy per degree day model was adequate. But in general, any procedure that accurately predicts the building thermal load is acceptable.

5. The average domestic hot water demand as a function of the time of day and occupancy was established in the development of the procedure, but in general is highly dependent upon the habits of the occupants. However, it has been determined that the actual time distribution of the water heating load will have only a small effect upon the long-term performance for solar heating systems combining domestic hot water and space heating.
 6. Since in most instances flat plate collectors are utilized for heating buildings, the collector component parameters are only valid for modeling flat plate collectors.
 7. The system evaluation procedure as outlined can only accurately predict system performance for systems using south facing collector arrays. Cases of different collector orientations must be analyzed using a different procedure.
- c. The fluid mass flow rate through the collectors may vary considerably for different systems. The collector efficiency curve used as part of this evaluation procedure shall have been generated for the collector flow rate used in the system under consideration.
 - d. In the evaluation procedure, an example problem has been included for a system using the basic System I design.
 - e. The system evaluation procedure consists basically of six steps:
 1. Calculate the monthly total heating load (L).
 2. Calculate the monthly incident solar radiation on the collector array (S).
 3. Determine the component parameters; i.e., collector area, storage capacity, etc.

4. Knowing 1, 2, and 3, calculate two dimensionless parameters (D_1 , D_2) for each month.
5. Using D_1 and D_2 for each month, calculate the monthly fraction of the heating load supplied by solar energy (f).
6. With the monthly loads and monthly functions supplied by solar, calculate (F_{annual}) the annual fraction of the heating load supplied by solar energy.

Nomenclature

A_c - Collector aperture area (ft²)

c_p - Fluid capacitance [Btu/(lb°F)]

D_1, D_2 - Dimensionless parameters

Δt_d - Temperature difference for building design temperature conditions (°F)

Δt - Total number of hours in a particular month (h)

θ - Collector tilt (°)

E - Solar energy supplied for a particular month (Btu/Month)

E_{Total} - Solar energy supplied for an entire year (Btu/Year)

f - Monthly fraction of total heating load supplied by solar energy

F_{annual} - Yearly fraction of the total heating load supplied by solar energy

F_R - Collector heat removal factor

γ - Solar collector azimuth angle (For Due South = 180°)

\bar{I}_H - Monthly average of the daily radiation incident on a horizontal surface
[Btu/(Day·ft²)]

\bar{I}_T - Monthly average of the daily radiation incident on a tilted surface
[Btu/(Day·ft²)]

\bar{K}_t - Ratio of the monthly averages of the daily radiation on a horizontal surface to the extraterrestrial radiation on a horizontal surface

K_1 - Correction factor to correct f for various storage volumes

L - Total heating and hot water load for a particular month (Btu/Month)

L_{Total} - Total heating and hot water load for an entire year (Btu/Year)

m - Mass of domestic hot water used for a particular month (lb)

\dot{m} - Flow rate of the working fluid (lb/hr)

M - Mass of thermal storage (lb)

N - Number of days in a particular month

ϕ - Latitude

Q_s - Space heating load for a particular month (Btu/Month)

Q_w - Domestic hot water heating load for a particular month (Btu/Month)

q_d - Building design rate of sensible heat loss (Btu/h)

\bar{R} - Ratio of the monthly average-daily radiation on a tilted surface to that on a horizontal surface

S - Monthly incident solar radiation on a tilted surface [Btu/(month'ft²)]

\bar{t}_a - Monthly average ambient air temperature (°F)

t_s - Temperature of domestic hot water supply (°F)

t_m - Temperature of water main supply (°F)

t_{ref} - Reference temperature, 212°F

$\Delta time$ - total number of hours in each month

$\overline{\tau\alpha}$ - Average transmissivity-absorptivity product for design purposes

$(\tau\alpha)_n$ - Transmissivity-absorptivity product at normal incidence

U_L - Collector heat loss factor [Btu/(h·°F·ft²)]

UA - Building heat loss factor [Btu/(h·°F)]

PROCEDURE FOR EVALUATING SOLAR HEATING SYSTEM PERFORMANCE/SIZING

1. Total Heating Load

The total heating load is determined on a monthly basis for both space and domestic hot water heating.

The space heating and domestic hot water heating loads are calculated separately, and for combined systems the monthly individual loads are added to get a monthly total load.

a. Space Heating Load

It is recommended that the space heating load for each month be calculated using the degree-day method. It is based on the assumption that over a long-term, solar and internal heat gains will offset the residential heat loss when the mean daily outdoor air temperature is 65°F and that the long-term heating load will be proportional to the difference between the mean daily temperature and 65°F. Tables of degree-days with a base of 65°F have been constructed and are published for a large number of cities in Chapter 43 of the 1973 ASHRAE System Handbook. However, residential insulation practices have improved over the past 40 years from virtually none in 1930 to R-11 in walls and R-19 in ceilings today. In addition, internal heat gains have also increased dramatically. Recent research indicates that these larger internal gains coupled with the increased insulation levels are sufficient to offset a home's heat loss of mean daily temperatures as low as 55°F. In consideration of this, a modified degree-day procedure is suggested. It consists of the use of a proportionality factor. This factor can range in value from 0.60 to 0.80 depending on the insulation level, weather pattern, internal gains, etc. However, it is recommended that you use a value of 0.75 unless practical experience in your own locality would dictate the use of a different value.

- a-1 Calculate the building design heat loss rate (q_d). Any technique consistent with the Minimum Property Standards, e.g., NESCA Manual J., is acceptable. The heating system shall be designed to maintain the indoor temperature at 70°F for 97.5 percent design winter temperatures for the geographic area in which the system is to be installed.
- a-2 Obtain the monthly total degree-days from the ASHRAE Systems Handbook for the particular location for each month.
- a-3 Calculate the monthly space heating load using the equation:

$$Q_s = (PF) (24) (UA) (\text{Degree-Days}), \quad (1)$$

where

$$PF = 0.75$$

$$UA = \frac{q_d}{\tau_d} = \frac{\left[\begin{array}{c} \text{Design} \\ \text{Heat} \\ \text{Loss Rate} \end{array} \left(\frac{\text{Btu}}{\text{h}} \right) \right]}{\left[\begin{array}{c} \text{Temperature difference between inside} \\ \text{and outside for design conditions } ^\circ\text{F} \end{array} \right]} \quad (2)$$

$$= \frac{\left[\begin{array}{c} \text{Design} \\ \text{Heat} \\ \text{Loss Rate} \end{array} \left(\frac{\text{Btu}}{\text{h}} \right) \right]}{70^\circ\text{F local winter design temperature}}$$

Local winter design temperatures for many US cities are tabulated in the ASHRAE Handbook of Fundamentals.

a-4 Calculate the monthly average ambient air temperature (\bar{t}_a) from available weather data for a specific geographical location. Tables are included in Appendix A of the NBS Intermediate Minimum Property Standards, NBS 76-1059.

b. Domestic Hot Water Heating Load

- b-1 Determine the required volume of domestic hot water (Gal) required on a monthly basis. Then, knowing the volume, calculate the mass (m) using a value of 8.33 lb/gal.
- b-2 Determine the water main temperature (t_m) or assume $t_m = 55^\circ\text{F}$.
- b-3 Determine the domestic hot water supply temperature (t_s) or assume $t_s = 140^\circ\text{F}$.
- b-4 Calculate the monthly domestic hot water heating load using the following equation:

$$Q_w = \left[\frac{\text{(lb) DHW Consumed}}{\text{Month}} \right] \left[\text{Specific Heat of Water} \right] \left[\text{Temp. Supply} - \text{Temp. Water Main} \right] \quad (3)$$

$$Q_w = mc_p (t_s - t_m)$$

For situations where the domestic hot water requirements cannot be reasonably estimated, a load of 1.6×10^6 Btu/month may be assumed for a typical residence. This is equivalent to approximately 90 gallons of hot water use per day.

c. Total Heating Load

The monthly total heating and hot water load is the sum of the space heating and domestic hot water load for each month.

$$L = Q_S + Q_W \quad (4)$$

2. Incident Solar Radiation

The incident solar radiation is determined for a particular collector tilt on a monthly basis.

a. Monthly Average of the Daily Radiation incident on a Horizontal Surface, \bar{I}_H .

Values for \bar{I}_H for each month may be taken from Table A-4 of the Intermediate MPS and interpolated between cities to get \bar{I}_H values for intermediate points. Measured radiation data can be used for a particular location whenever it is available.

b. Ratio of the Monthly Averages of the Daily Radiation on a Horizontal Surface to the Extraterrestrial Radiation, (\bar{K}_t) .

Values for \bar{K}_t for each month may be taken from Table A-4 of the Intermediate MPS and interpolated between cities to get \bar{K}_t values for intermediate points.

c. Ratio of the Monthly Average Daily Radiation on a Tilted Surface to that on a Horizontal Surface for Collectors Facing Due South (\bar{R}).

Using Table A-5 of the Intermediate MPS and knowing collector tilt (θ), latitude (ϕ), and K_t , determine \bar{R} for each month.

- d. Monthly Average Daily Radiation on a Tilted Surface, (\bar{I}_T).

Knowing \bar{I}_H and \bar{R} for each month, calculate \bar{I}_T on a monthly basis using the equation:

$$\bar{I}_T = (\bar{I}_H) (\bar{R}) \quad (5)$$

- e. Total Monthly Radiation on a Tilted Surface, (S)

\bar{I}_T , the monthly average daily radiation on a tilted surface, must be multiplied by the total days in each month, (N) to obtain total insolation for each month.

$$S = (\bar{I}_T) (N) \quad (6)$$

- f. Shading

Shading should not be neglected in calculating the incident solar radiation on a particular collector array. The amount of shading is strongly dependent on the collector site and orientation; thus, each case must be analyzed separately.

3. Component Parameters

The component parameters characterize the various components that make up the system.

- a. Solar Collector

Using collector thermal performance efficiency curves provided by the manufacturer covering the appropriate range of operational temperature, insolation, tilt angles and flow rates, determine the collector parameters $F_R U_L$ and $F_R (\alpha\tau)_\eta$.

For the Solar Energy Products collector at a system airflow of 2.5 CFM per square foot of collector area, the performance parameters are:

$$F_{R L} U_L = 1.04 \text{ Btu/Hr. Ft.}^2 \cdot \text{F}$$

$$F_R (\tau\alpha)_\eta = 0.57$$

b. Storage

In general for solar heating systems, an average storage capacity of 15 BTU/°F per square foot of collector has been determined as near economic optimum. This is equivalent to 0.75 cubic feet of pebble bed volume per square foot of collector area. For storage volumes other than $0.75 \text{ Ft}_p^3 / \text{Ft}_c^3$, a correction factor will be introduced later to correct the value of the predicted system thermal performance.

4. Dimensionless Parameters (D_1 , D_2)

The dimensionless parameters D_1 and D_2 characterize the entire solar heating system thermal effectiveness. Calculate the two dimensionless parameters for each month using the factors defined previously on a monthly basis according to the following equations:

$$D_1 = \frac{\text{Energy absorbed by collector Plate}}{\text{Total heating load}} \quad (7)$$

$$= [A_c] [F_R (\tau\alpha)_\eta \frac{(\overline{\tau\alpha})}{(\tau\alpha)_\eta}] \frac{S}{L}$$

$$D_2 = \frac{\text{Ref. Collector Plate Energy Losses}}{\text{Total Heating Load}} \quad (8)$$

$$= [A_c] [F_{R,L}] [t_{\text{ref}} - \bar{t}_a] \frac{\Delta \text{ time}}{L}$$

$t_{\text{ref}} = 212^\circ\text{F}$ (arbitrarily chosen reference temperature).

$\Delta \text{time} =$ total number of hours in each month.

$\bar{t}_a =$ average ambient air temperature for the particular month.

$$\frac{\overline{\tau\alpha}}{(\tau\alpha)_\eta} = 0.90 \text{ to account for the change in the value of the effective transmission-absorption product with incident angle throughout a day.}$$

5. Monthly Fraction of Total Heating Load Supplied by Solar Energy (f)

The fraction of the heating load supplied by solar energy (f) can be determined from Figure 5-2 as a function of the dimensionless parameters, D_1 and D_2 .

Locate the two dimensionless parameters on Figure 5-2 and determine the fraction of total heating load supplied by solar energy (f) on a monthly basis.

6. Annual Fraction of the Total Heating Load Supplied by Solar Energy
(F_{annual})

It was mentioned earlier that the procedure was intended to provide an estimate of system long-term performance (yearly basis). In order to calculate f on a yearly basis, the following calculations must be performed.

- a. The actual solar energy supplied for each month must be calculated as follows:

$$\begin{aligned}
 E_{\text{Jan}} &= f_{\text{Jan}} L_{\text{Jan}} \\
 E_{\text{Feb}} &= f_{\text{Feb}} L_{\text{Feb}} \\
 E_{\text{Dec}} &= f_{\text{Dec}} L_{\text{Dec}}
 \end{aligned}
 \tag{9}$$

Total the solar energy supplied for the entire year by summing the contributions from each month.

$$E_{\text{Total}} = E_{\text{Jan}} + E_{\text{Feb}} + \dots + E_{\text{Dec}} \tag{10}$$

- b. Calculate the total heating load for the entire year (L_{Total}).
- c. Knowing the total annual solar energy supplied by the heating system (E_{Total}) and the total annual heating load (L_{Total}), determine F_{annual} for the entire year from the following equation:

$$F_{\text{annual}} = \frac{E_{\text{total}}}{L_{\text{total}}} \tag{11}$$

- d. Correction Factors for F_{annual}

d-1 To correct for various storage capacities other than $0.75 \text{ Ft}_p^3 / \text{Ft}_c^2$, use Figure 5-3 to obtain the correction factor (K_1).

d-2 Utilizing the correction factor K_1 , the corrected and final value of F_{annual} may be calculated as follows:

$$F_{\text{annual}} = (K_1) F_{\text{annual}} \tag{12}$$

Example Case

The procedure will be illustrated for an example case of a house located in Madison, Wisconsin, utilizing the System I design.

1. Total Heating Load

The total heating load is equal to the sum of the space heating load and the domestic hot water heating load.

a. Space Heating Load

a-1 The collector array is comprised of collectors facing due south at a tilt angle of 43° . Knowing the building thermal characteristics (heat transfer coefficients and areas of surfaces exposed to the outside) and using Manual J, the design temperature difference (Δt_d) and design heat loss (q_d) were found to be 75°F and $71,700 \text{ Btu/h}$ respectively.

a-2 Monthly total degree days (DD) for Madison were taken from the ASHRAE Systems Handbook.

a-3 Monthly space heating load (Q_s) was then calculated using the specified equations. For example, for the month of February DD = 1274:

$$Q_s = (PF) (24) (UA) (\text{Degree Days})$$

$$UA = \frac{q_d}{\Delta t_d}$$

$$UA = \frac{71,700 \text{ Btu/h}}{75^\circ\text{F}} = 956 \frac{\text{Btu}}{\text{h}^\circ\text{F}}$$

$$\begin{aligned} Q_s (\text{Feb}) &= (0.75) (24) (956) (1274) \\ &= 21.9 \times 10^6 \text{ Btu} \end{aligned}$$

All values for the example problem are compiled in Table 5-1.

b. Domestic Hot Water Heating Load

b-1 Assume for this example, that hot water requirements are 82.7 gallons per day. Monthly requirements are then,

$$\left(82.7 \frac{\text{gal}}{\text{Day}}\right) \left(N \frac{\text{Days}}{\text{Month}}\right)$$

Values obtained are tabulated in Table 5-1 for the example problem. As an example for February,

$$\frac{\text{lb}}{\text{month}} = \left(\frac{\text{gal}}{\text{month}}\right) \left(\frac{8.3 \text{ lb}}{\text{gal}}\right)$$

$$m = (2316) (8.3) = 19,176 \frac{\text{lb}}{\text{month}}$$

b-2 Water main temperature (t_m) was assumed to be ($t_m = 55^\circ\text{F}$).

b-3 Domestic hot water supply temperature (t_s) was assumed to be set at ($t_s = 140^\circ\text{F}$).

b-4 Monthly domestic hot water heating load (Q_w) is then,

$$Q_w = mc_p (t_s - t_m)$$

where c_p is the specific heat of water ($c_p = 1 \text{ Btu}/[\text{lb} - ^\circ\text{F}]$).

Q_w is then calculated on a monthly basis and tabulated in Table 5-1. For instance, for February,

$$Q_w = \left(19,176 \frac{\text{lb}}{\text{month}}\right) \left(1 \frac{\text{Btu}}{\text{lb} \cdot ^\circ\text{F}}\right) (140^\circ\text{F} - 55^\circ\text{F})$$
$$= 1.63 \times 10^6$$

- c. Total Heating Load (L) is then the sum of space heating (Q_s) and water heating (Q_w).

$$L = Q_s + Q_w$$

For instance, for February,

$$\begin{aligned} L &= 21.9 \times 10^6 \text{ Btu} + 1.63 \times 10^6 \text{ Btu} \\ &= 23.5 \times 10^6 \text{ Btu} \end{aligned}$$

Values of L for each month are tabulated in Table 5-1 for the example problem.

2. Incident Solar Radiation

- a. Monthly Averages of the Daily Radiation Incident on a Horizontal Surface (\bar{I}_H) were taken from Table A-4 of the Intermediate MPS and are tabulated in Table 5-1 for the example problem.
- b. Monthly values for K_t were taken from Table A-4 of the Intermediate MPS and are also tabulated in Table 5-1.
- c. Knowing the collector tilt ($\theta = 43^\circ$), the latitude ($\phi = 43^\circ$), and monthly K_t values; monthly \bar{R} values were taken from Table A-5 of the Intermediate MPS and tabulated in Table 5-1.

For instance, in February, $\bar{K}_t = .47$. Referring to Table A-5 of the Intermediate MPS ($\bar{K}_t = .5$) and determining the latitude minus tilt difference ($\theta - \phi = 43^\circ - 43^\circ = 0^\circ$) which places one in the second tier down of Table A-5, the R value under the February column opposite latitude 43° is $\bar{R} = 1.57$.

Table 5-1. Monthly Values for K_t .

DOMESTIC HOT WATER

Space Heating Load			Heating Load		Total Heating Load		Incident Solar Radiation				
	Degree Days	BTU Month Q_s	DHW Month $\frac{m}{\text{Gal/1bm}}$	BTU Month Q_w	BTU Month $L=Q_s + Q_w$	t_a (°F) Ambient Air Temperature	BTU Day ft ² \bar{I}_H	K_t	R	BTU Day ft ² $\bar{I}_T = \bar{I}_H R$	BTU Month ft ² S
Jan.	1473	25.3x10 ⁶	2565 21292	1.81x10 ⁶	27.1x10 ⁶	21.8	565	.485	1.90	1074	33.4x10 ³
Feb.	1274	21.9	2316 19222	1.63	23.5	24.6	812	.496	1.57	1284	35.8
Mar.	1113	19.1	2565 21292	1.81	20.9	35.3	1232	.546	1.31	1615	50.2
Apr.	618	10.6	2484 20617	1.75	12.3	49.0	1456	.494	1.06	1543	46.4
May	310	5.32	2565 21292	1.81	7.13	61.0	1746	.509	0.93	1624	50.5
June	132	1.75	2484 20617	1.75	3.50	70.9	2031	.558	1.88	1789	53.9
July	25	.42	2565 21292	1.81	2.23	76.8	2048	.578	1.90	1843	57.4
Aug.	40	.68	2622 21762	1.85	2.49	74.4	1746	.556	1.00	1741	54.0
Sep.	174	2.99	2485 20617	1.75	4.74	65.6	1445	.579	1.21	1748	52.3
Oct.	474	8.15	2565 21292	1.81	9.96	53.7	994	.547	1.54	1531	47.0
Nov.	930	15.9	2484 20617	1.75	17.7	37.8	556	.434	1.73	962	29.8
Dec.	1330	22.8	2565 21292	1.81	24.6	25.4	496	.480	2.09	1036	32.3

- d. Monthly Average Daily Radiation on a Tilted Surface (\bar{I}_T) is calculated using,

$$\bar{I}_T = (\bar{I}_H) (\bar{R})$$

and tabulated in Table 5-1. For example, in February,

$$\bar{I}_T = (818)(1.57) = 1284 \frac{\text{Btu}}{\text{Day} \cdot \text{ft}^2}$$

- e. Total Average Insolation per Month (S) is calculated using

$$S = (\bar{I}_T) (N)$$

where N is the number of days in the month. S is then tabulated in Table 5-1. For example, in February,

$$\begin{aligned} S &= \left(1284 \frac{\text{Btu}}{\text{Day} \cdot \text{ft}^2} \right) \left(28 \frac{\text{Days}}{\text{Month}} \right) \\ &= 35.8 \times 10^3 \frac{\text{Btu}}{\text{Month} \cdot \text{ft}^2} \end{aligned}$$

- f. Assume no shading of the collector array in this example.

3. Component Parameters

a. Solar Collector

The collectors are constructed with a single glass cover plate and an aluminum absorber coated with a non-selective flat black paint.

With a system air flow rate of $2.5 \text{ CFM/Ft}^2_{\text{collector}}$,

$$F_{R,L} U_L = 1.04 \text{ Btu/Hr Ft}^2 \text{ } ^\circ\text{F}$$

$$F_R (\tau\alpha)_\eta = 0.57$$

For this example a collector area (A_c) of 500 square feet is assumed.

- b. For this example, the thermal storage consists of a pebble bed of dimensions 7' W x 7' L x 6' H. The storage volume per unit collector area is then

$$\frac{7 \times 7 \times 6 \text{ Ft}^3_p}{500 \text{ Ft}^2_c} = 0.59 \frac{\text{Ft}^3_p}{\text{Ft}^2_c}$$

4. Dimensionless Parameters (D_1, D_2)

The dimensionless parameters D_1 and D_2 were calculated for the month of January as follows:

$$D_1 = [A_c] [F_R (\tau\alpha)_\eta] \left[\frac{\overline{\tau\alpha}}{(\tau\alpha)_\eta} \right] \frac{S}{L}$$

$$= [500] [.57] [.90] \frac{33.4 \times 10^3}{27.1 \times 10^6} = .32$$

$$D_2 = [A_c] [F_{RUL}] [t_{ref} - t_{amb}] \frac{\text{time}}{L}$$

$$[500] [1.04] [212-21.8] \frac{744}{27.1 \times 10^6} = 2.72$$

Computed values for each month are compiled in Table 5-2.

5. Monthly Fraction of Total Heating Load Supplied by Solar Energy, (f)

By locating the dimensionless parameters D_1 and D_2 on Figure 5-2, f can be determined on a monthly basis. For January, the value for (f) was 0.17.

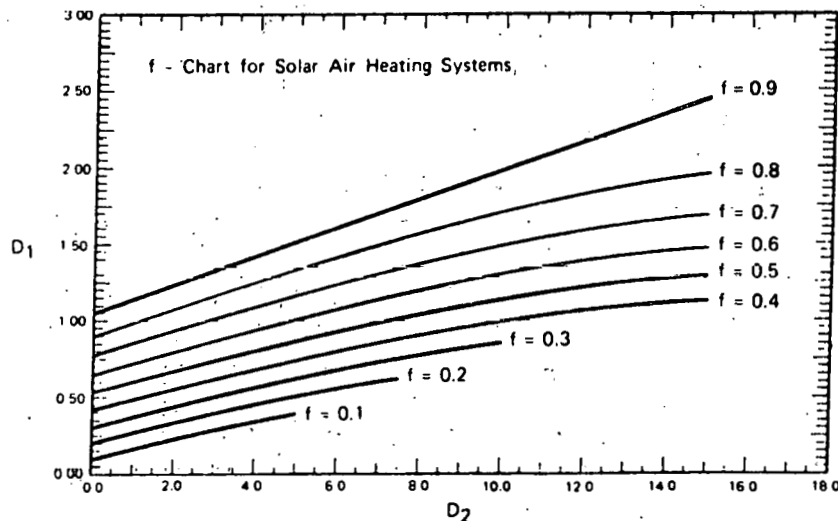

Figure 5-2. Dimensionless Parameters for D_1 and D_2 .

Table 5-2.

DIMENSIONLESS PARAMETERS

	BTU MONTH L	BTU MONTH ft ² S	HRS MONTH time	$\frac{^{\circ}\text{F}}{t_a}$	D1	D2
Jan	27.1×10^6	33.4×10^3	744	21.8	.32	2.72
Feb.	23.5	35.8	696	24.6	.33	2.89
Mar.	20.9	50.2	744	35.3	.62	3.27
April	12.3	46.4	720	49.0	.97	4.96
May	7.13	50.5	744	61.0	1.82	8.19
June	3.50	53.9	720	70.9	3.95	15.09
July	2.23	57.4	744	76.8	6.60	23.46
Aug.	2.49	54.0	744	74.4	5.56	21.38
Sept.	4.74	52.3	720	65.6	2.83	11.56
Oct.	9.96	47.0	744	53.7	1.21	6.15
Nov.	17.7	29.8	720	37.8	.43	3.68
Dec.	24.6	32.3	744	25.4	.35	2.93

FRACTION OF THE TOTAL HEATING
LOAD SUPPLIED BY SOLAR ENERGY

f	BTU MONTH E
.17	4.61×10^6
.21	4.94
.40	8.36
.60	5.12
.90	6.42
1.0	3.50
1.0	2.23
1.0	2.49
1.0	4.74
.68	6.77
.20	3.54
.17	4.16

$$E \text{ total} = 56.9 \times 10^6$$

$$L \text{ total} = 156 \times 10^6$$

$$F \text{ annual} = \frac{E \text{ total}}{L \text{ annual}}$$

$$= .36$$

$$K_1 = 0.95$$

$$F' \text{ annual} = (K_1)(K_2) F \text{ annual}$$

$$= .57$$

6. Annual Fraction of the Total Heating Load Supplied by Solar Energy (F_{annual})

a. The solar energy supplied for the month of January is,

$$\begin{aligned} E_{\text{Jan}} &= (f_{\text{Jan}}) \\ &= (.17)(27.1 \times 10^6) = 4.61 \times 10^6 \text{ Btu} \end{aligned}$$

The total solar energy supplied for the entire year is,

$$\begin{aligned} E_{\text{total}} &= E_{\text{Jan}} + E_{\text{Feb}} + \dots + E_{\text{Dec}} \\ &= 56.9 \times 10^6 \end{aligned}$$

b. The total heating load for the entire year is,

$$L_{\text{total}} = 156 \times 10^6 \text{ Btu}$$

c. f for the entire year is equal to,

$$\begin{aligned} F_{\text{annual}} &= \frac{E_{\text{total}}}{L_{\text{total}}} \\ &= \frac{56.9 \times 10^6}{156 \times 10^6} = 0.36 \end{aligned}$$

d. Correction Factors for F_{annual}

d-1 The 7' x 7' x 6' pebble bed has a storage volume of $0.59 \text{ Ft}^3/\text{Ft}^2$ of collector area.

Using Figure 5-3, the correction factor K_1 is equal to 0.97

d-2 $F_{\text{annual}} = 0.97 (0.36) = 0.35$

Therefore, for the example case with the collector and storage sizes selected the System I design will supply approximately 35% of the energy required for heating and hot water.

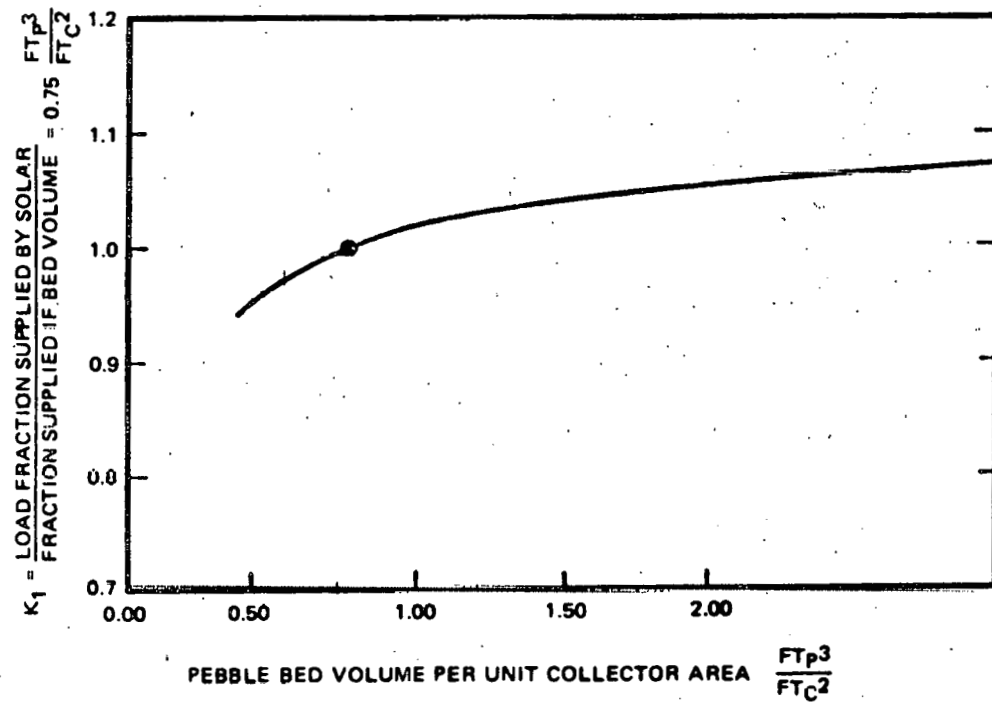

Figure 5-3. Correction Factor for K_1 .

REFERENCES 6

1. NBSIR 76-1059, "Intermediate Minimum Property Standards for Solar Heating and Domestic Hot Water Systems."
2. National Environmental Systems Contractors Association Design and Installation Manuals for Warm Air Heating and Air Conditioning Systems.
3. American Society of Heating Refrigerating and Air Conditioning Engineers, Inc. Handbook 1976 Systems; Guide and Data Book Fundamentals.

NASA-MSFC-C