

302
10/10/78
minutes NT 15

DR. 576

210-590

DOE/NASA CONTRACTOR REPORT

MASTER

DOE/NASA CR-150515

SOLAFERN SOLAR SYSTEM DESIGN BROCHURE

Prepared by

Solafern, Ltd.
536 MacArthur Boulevard
Bourne, MA 02532

Under Contract NAS8-32246 with

National Aeronautics and Space Administration
George C. Marshall Space Flight Center, Alabama 35812

for the U. S. Department of Energy

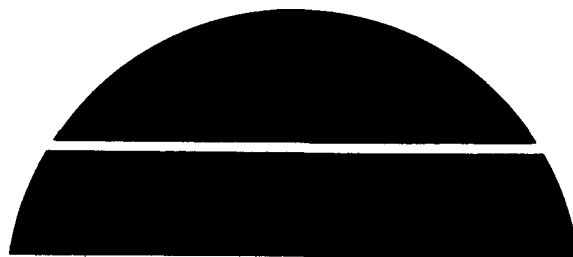

U.S. Department of Energy



Solar Energy

DISSEMINATION OF THIS DOCUMENT IS UNLIMITED

NOTICE

This report was prepared to document work sponsored by the United States Government. Neither the United States nor its agents the United States Department of Energy, the United States National Aeronautics and Space Administration, nor any federal employees, nor any of their contractors, subcontractors or their employees, make any warranty, express or implied, or assume any legal liability or responsibility for the accuracy, completeness, or usefulness of any information, apparatus, product or process disclosed, or represent that its use would not infringe privately owned rights.

DISCLAIMER

This report was prepared as an account of work sponsored by an agency of the United States Government. Neither the United States Government nor any agency thereof, nor any of their employees, makes any warranty, express or implied, or assumes any legal liability or responsibility for the accuracy, completeness, or usefulness of any information, apparatus, product, or process disclosed, or represents that its use would not infringe privately owned rights. Reference herein to any specific commercial product, process, or service by trade name, trademark, manufacturer, or otherwise does not necessarily constitute or imply its endorsement, recommendation, or favoring by the United States Government or any agency thereof. The views and opinions of authors expressed herein do not necessarily state or reflect those of the United States Government or any agency thereof.

DISCLAIMER

Portions of this document may be illegible in electronic image products. Images are produced from the best available original document.

1. REPORT NO. DOE/NASA CR-150515	2. GOVERNMENT ACCESSION NO.	3. RECIPIENT'S CATALOG NO.	
4. TITLE AND SUBTITLE Solafern Solar System Design Brochure		5. REPORT DATE December 1977	
		6. PERFORMING ORGANIZATION CODE	
7. AUTHOR(S)		8. PERFORMING ORGANIZATION REPORT #	
9. PERFORMING ORGANIZATION NAME AND ADDRESS Solafern, Ltd. 536 MacArthur Boulevard Bourne, MA 02532		10. WORK UNIT NO.	
		11. CONTRACT OR GRANT NO. NAS8-32246	
12. SPONSORING AGENCY NAME AND ADDRESS National Aeronautics and Space Administration Washington, D. C. 20546		13. TYPE OF REPORT & PERIOD COVERED Contractor Report	
		14. SPONSORING AGENCY CODE	
15. SUPPLEMENTARY NOTES This work was performed under the technical management of Mr. Val Fogle, Marshall Space Flight Center, National Aeronautics and Space Administration.			
16. ABSTRACT The Solafern system is a complete residential solar space heating and hot water system. When installed in a highly insulated energy saver home, the solar system can supply a large percentage of the total energy demand for space heating and domestic hot water. Low maintenance, durable and efficient air heating collectors are used. The collectors have a selective absorber and a tempered glass cover nearly one-quarter of an inch thick with an aluminum frame. The solar energy can be delivered directly to the living area when there is a demand; otherwise, it is stored in the form of hot water. Hot water storage is accomplished through the use of an air-to-water exchanger. The hot water storage is used simultaneously to preheat the domestic hot water, as well as to store energy for space heating. The system has a one-year warranty on all parts and service and a five-year warranty on the collector, except for glass breakage. The service life of the collector is estimated as 30 years.			
17. KEY WORDS		18. DISTRIBUTION STATEMENT Unclassified-Unlimited <i>William A. Brooksbank, Jr.</i> William A. Brooksbank, Jr. Manager Solar Heating & Cooling Project Office	
19. SECURITY CLASSIF. (of this report) Unclassified	20. SECURITY CLASSIF. (of this page) Unclassified	21. NO. OF PAGES 47	22. PRICE NTIS



SOLAFERN SOLAR SYSTEM

DESIGN BROCHURE

PREPARED FOR
GEORGE C. MARSHALL SPACE FLIGHT CENTER
UNDER
CONTRACT NAS 8 - 32246

SOLAFERN, LTD.

536 MacArthur Boulevard

Bourne, MA 02532

(617) 563-7181

December 1, 1977

NOTICE

This report was prepared as an account of work sponsored by the United States Government. Neither the United States nor the United States Department of Energy, nor any of their employees, nor any of their contractors, subcontractors, or their employees, makes any warranty, express or implied, or assumes any legal liability or responsibility for the accuracy, completeness or usefulness of any information, apparatus, product or process disclosed, or represents that its use would not infringe privately owned rights.

TABLE OF CONTENTS

<u>SECTION</u>		<u>PAGE</u>
1.	SYSTEM DESCRIPTION	1-1
2.	COLLECTOR INSTALLATION	2-1
3.	ETM INSTALLATION	3-1
4.	ELECTRICAL	4-1
5.	PIPING	5-1
6.	EQUIPMENT REQUIRED	6-1
7.	PHYSICAL DATA	7-1
8.	SELECTION PROCEDURE	8-1
9.	GUIDE SPECIFICATIONS	9-1

DESIGN DATA BROCHURE

1. SYSTEM DESCRIPTION

The system consists of six modular subsystems:

1. Air-heating Solar Collector Subsystem.
2. Solar Energy Transport Subsystem.
3. Water-heating Energy Storage.
4. Control Subsystem.
5. Auxiliary Warm Air Furnace.
6. Auxiliary Domestic Hot Water Heater.

The system can supply space heating and domestic hot water as required. The proportional amount of heating provided by the solar system is dependent on the size of the solar subsystems. The size of the solar collector subsystem is developed by ganging individual collectors in rows and manifolding rows together. The number of collectors in a row and the number of rows are selected to suit the building. The energy storage system is sized by selecting the appropriate number of storage tanks and manifolding them. The energy transport functions are packaged into an energy transport module (ETM) containing the dampers, damper motors, blower and the heat exchanger. The air-flow is adjusted by selecting the correct motor size for the belt driven blower and adjusting the variable drive pulley sheaves.

Figure 1 is a functional flow diagram of the 5 operational modes:

Mode 1: Direct Solar Heating of Air Used for Space Heating.

Mode 2: Heating of Air Used for Space Heating by Stored Solar Energy.



Solafern, Ltd.

P. O. Box M
 536 MacArthur Boulevard
 Bourne, Massachusetts 02532
 Tel. (617) 563-7181
 TWX 710-391-1771 FERNENG BUZB

AIR HEATING
 SOLAFERN
 COLLECTOR
 ON ROOF

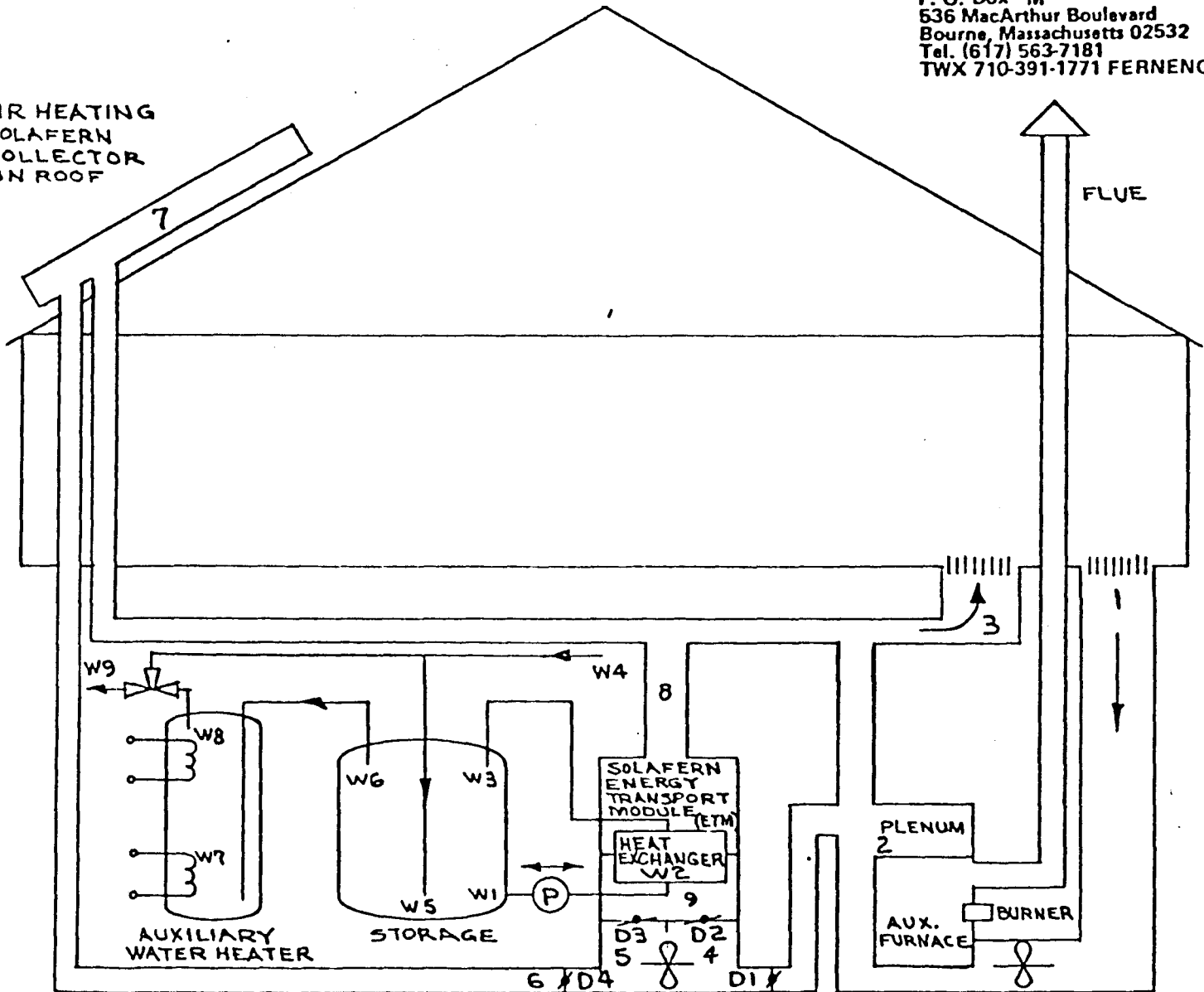

MODES:

1. DIRECT SPACE HEATING BY SOLAR: BURNER OFF/BOTH FANS ON-
 AIR FLOW PATHS: 1→2→3 AND 1→2→4→5→6→7→3.
2. WITHDRAWAL FROM STORAGE: BURNER OFF/BOTH FANS ON-
 AIR FLOW PATHS: 1→2→3 AND 1→2→4→5→9→8→3.
 WATER FLOW PATH: W3→W2→W1.
3. STORAGE: ETM FAN ON-
 AIR FLOW PATH: 4→5→6→7→8→9→4.
 WATER FLOW PATH: W1→W2→W3.
4. AUXILIARY FURNACE: BURNER ON-
 AIR FLOW PATH: 1→2→3.
5. DOMESTIC HOT WATER DRAW:
 WATER FLOW PATH: W4→W5→W6→W7→W8→W9.

DAMPERS

D1 | D2 | D3 | D4

1 | 0 | C | C | 0

2 | 0 | C | 0 | C

3 | C | 0 | C | 0

FUNCTIONAL FLOW DIAGRAM

Mode 3 : Storage of Solar Energy For Later Use.

Mode 4 : Heating of Air Used For Space Heating By The Auxiliary Furnace.

Mode 5 : Heating of Domestic Hot Water.

All modes are automatically controlled by thermostats:

1) Two-Stage Room Thermostat

The first stage calls for space heating by solar heated air either directly or from storage. The second stage controls the space heating by the auxiliary furnace.

2) Collector Thermostat

The collector thermostat enables Mode 1 to function when the collector is sufficiently warm.

3) Storage Thermostat

The storage thermostat enables Mode 2 to function when the storage is sufficiently warm, but the collector is not warm.

4) Differential Thermostat

The differential thermostat enables Mode 3 to function when the collector is sufficiently warmer than storage.

The control system selects the operating mode as shown in Figure 2. Mode 5 can operate anytime, drawing heated water from storage and further increasing the water temperature by the auxiliary heater as required.

When there is no demand for heat and the storage temperature increases, a pre-set temperature limiting thermostat shuts down the operation. The system is reset automatically when a demand lowers storage temperature.

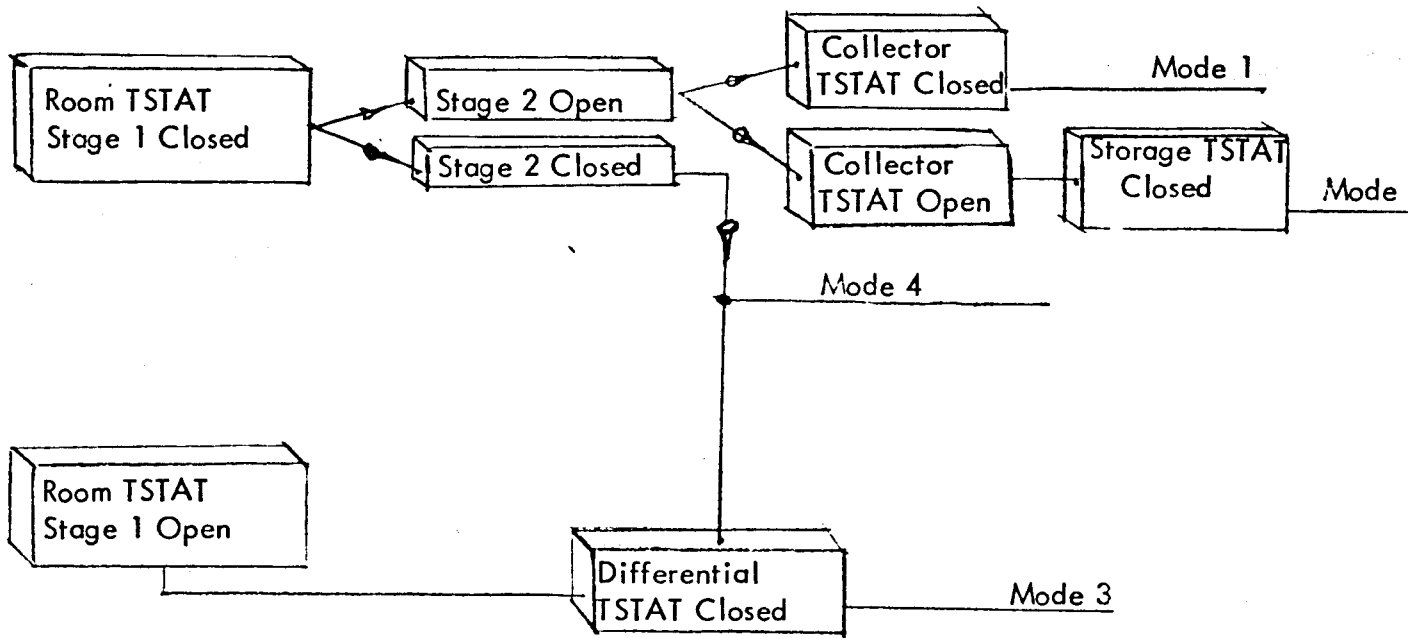

- Mode 1 - Space Heating Direct By Solar
- Mode 2 - Space Heating Via Stored Energy
- Mode 3 - Storage Of Solar Energy
- Mode 4 - Auxiliary Heating
- Mode 5 - Domestic hot water consumption - not shown above.

FIGURE 2 OPERATING MODE SELECTION

The system is designed to tolerate a no-flow temperature condition indefinitely. By virtue of the air-heating collectors there are no soldered joints in the collectors. The collector specifications are shown in Figure 3.

The collectors are a two-pass air heating type, with a single glass cover. Low Iron "crystal" clear tempered 7/32-inches thick glass is used. The glass is sized to withstand winds of 140 mph. The absorber consists of a black chrome selective coating electroplated to a textured copper sheet; the selective coating has a high solar absorptivity and low emissivity. The absorber is textured to enhance the heat transfer between the absorber and the heated air and provides improved efficiency.

The enclosure and ducts are of aluminum construction for light weight, corrosion resistance and smaller thermal capacitance than would result with steel. The collector is completely insulated with high temperature fiberglass and isocyanurate materials that have been selected through testing to insure minimum outgassing effects and to comply with The National Fire Protection Association Standards. A soft silicone rubber gasket is provided around the glass to make it weather tight and to allow for thermal cycling effects. The collector performance is shown in Figure 4; performance is based on testing conducted in accordance with the ASHRAE Test Standard 93.

The collectors are installed in continuous rows of 2 to 6 panels bolted together in series. A "starter" panel designated Type A contains the inlet and outlet connections; the B Type panel is used to make-up the length of a row and the C Type panel is used to complete a row. All panels have the same external appearance, differing internally.

SOLAFERN-30 SOLAR COLLECTOR

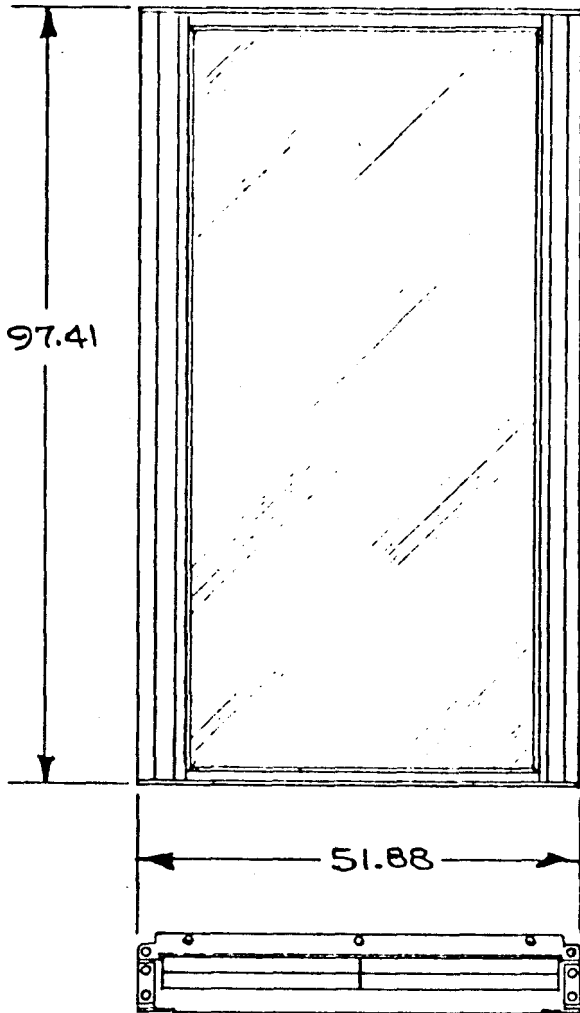

SPECIFICATIONS:

- SIZE: 97.41" X 51.88" X 9.5"
- WEIGHT: 190 LBS.
- COVER: LOW-IRON TEMPERED GLASS.
- EFFECTIVE AREA: 30 SQ. FT.
- HOUSING: ALUMINUM.
- HEAT TRANSFER FLUID: AIR.
- MOUNTING: ROOF, WALL OR GRADE MOUNTED WITH CONTINUOUS EXTERNAL FLANGES.
- MANIFOLDING: COLLECTORS MOUNT END TO END WITH SIMPLE EXTERNAL FLANGES.

COLLECTOR TYPES:

- 'A' - CONTAINS INLET & DISCHARGE DUCTING.
- 'B' - CONTAINS THRU FLOW DUCTING.
- 'C' - CONTAINS RETURN FLOW DUCTING.

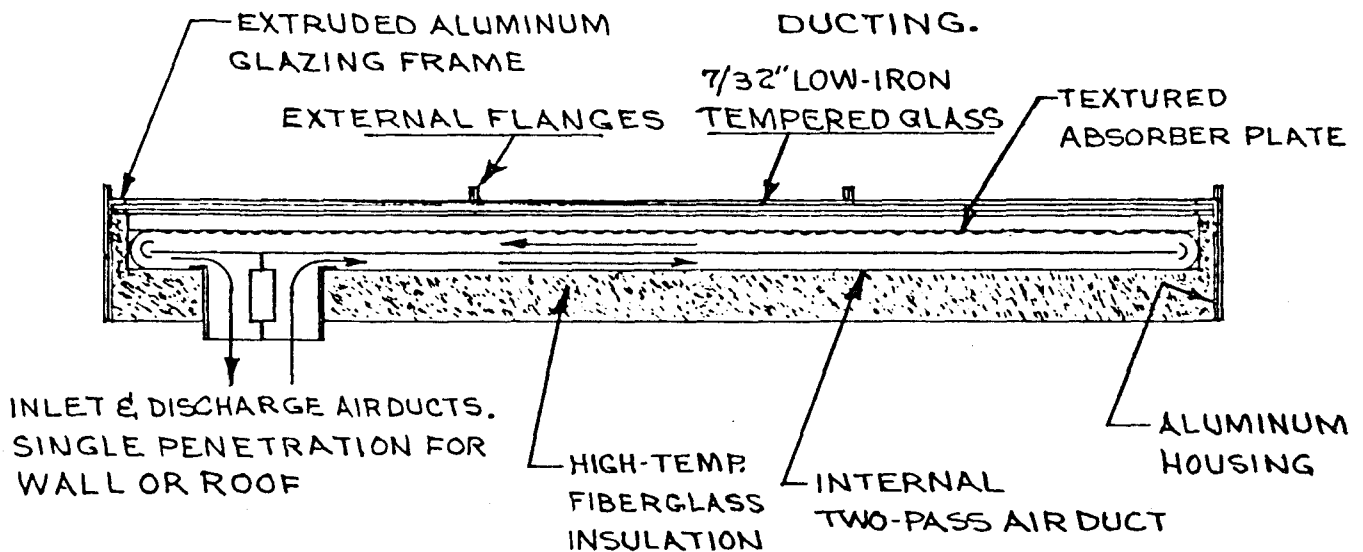

SOLAFERN LTD.
BUZZARDS BAY, MASSACHUSETTS
U.S.A.

DRAWN
DDL

APP'D
[Signature]

DATE
8-3-77

SOLAFERN-30
COLLECTOR SPECIFICATIONS
FIGURE 3

DWG. NO. 724-55-001

REV.



COLLECTOR EFFICIENCY

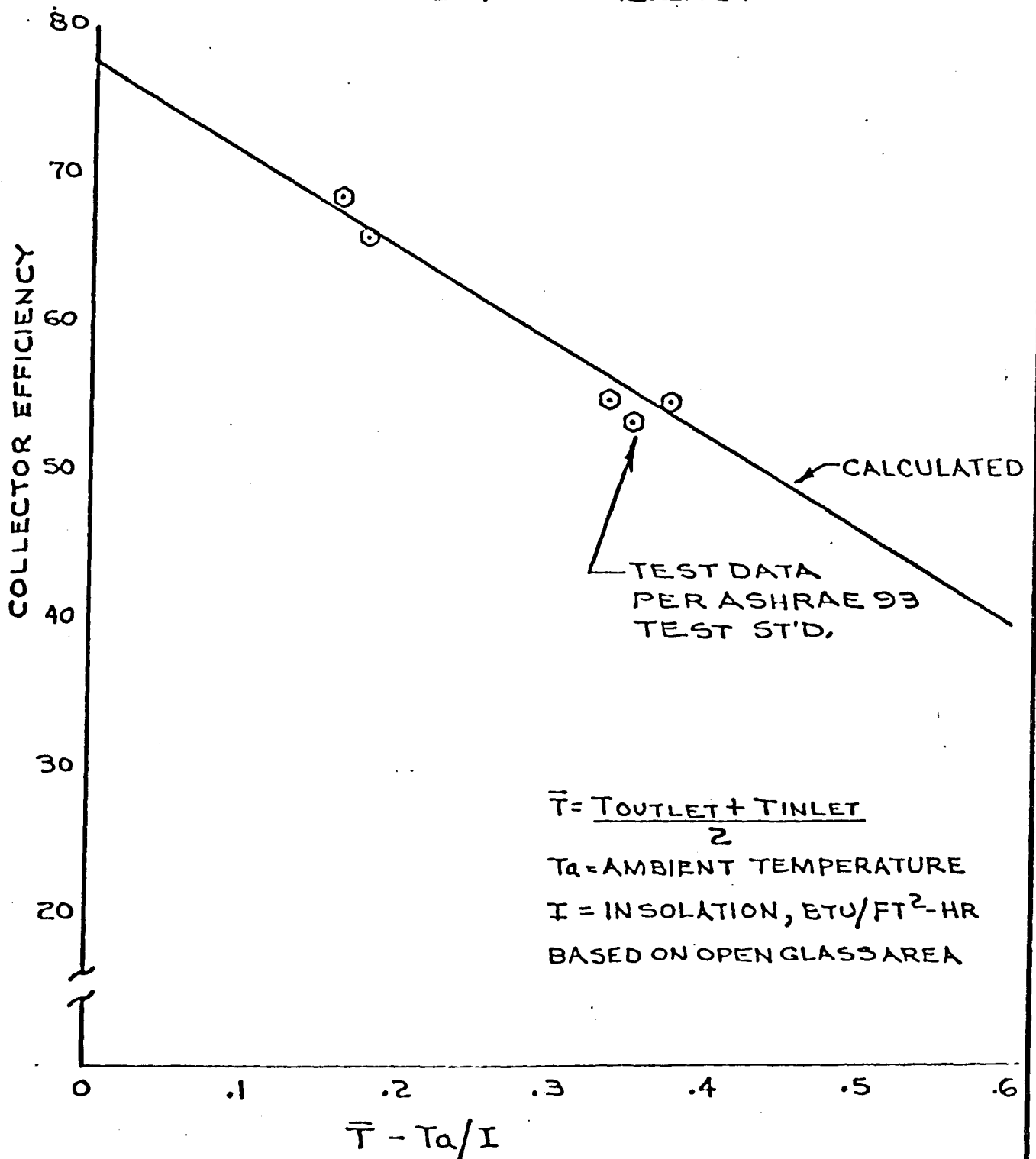

FERN ENGINEERING BUZZARDS BAY, MASSACHUSETTS U.S.A.	DRAWN PL	COLLECTOR EFFICIENCY FIGURE 4	
	APP'D		
	DATE 6/6/77	DWG. NO. 198-90-001	



2. COLLECTOR INSTALLATION

Azimuth

The collectors should face southwards as shown in Figure 5. The use of a compass indicates magnetic north (and south), and a correction is needed to locate true south. A surveyors plot plan will have true north indicated. If it is impractical to face the collectors southward, a small difference between the collector azimuth and true south has a minor effect on the energy that can be collected, as shown in Figure 6. A 45 degree difference between the azimuth and true south will reduce the collected energy by about 30%. Because of the increase in the temperature of the stored solar energy during the day, a westerly azimuth tends to be preferable to an easterly azimuth; however, local climatic conditions may be more optimal in the morning than in the afternoon, in which case, an easterly azimuth would be superior.

Tilt

Selection of the collector tilt angle (shown in Figure 7) is based on consideration of cost factors and collection efficiency. The collection efficiency is primarily dependent on the availability of solar insolation, which in turn is dependent on the tilt angle. Aligning the collector so its surface is normal to the sun's rays at any one time, maximizes the solar insolation available to the collector at that time. During the year, however, the relative position of the sun changes so that the sun's rays are inclined with respect to the collector and the full potential of the available insolation cannot be realized.

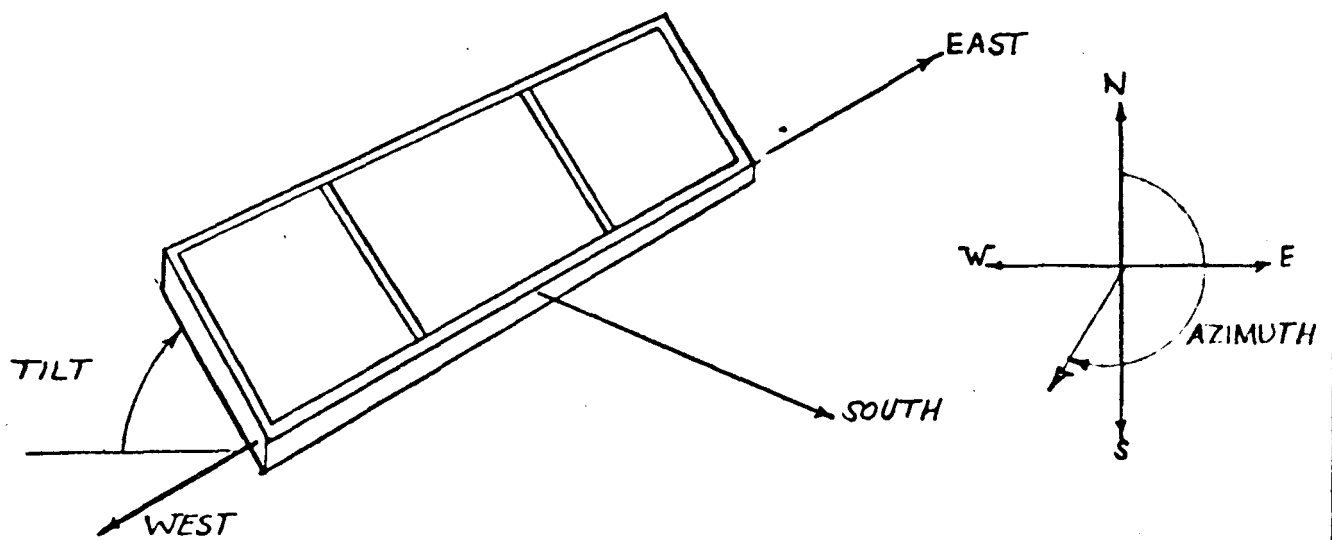

FIGURE 5 COLLECTOR TILT & AZIMUTH

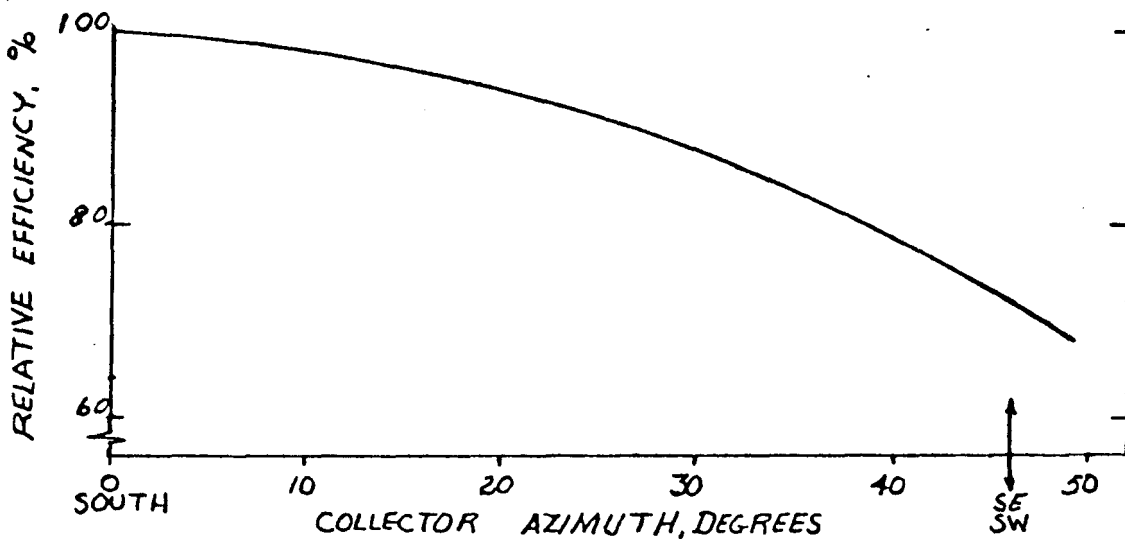

FIGURE 6 EFFECT OF COLLECTOR AZIMUTH ON SYSTEM EFFICIENCY

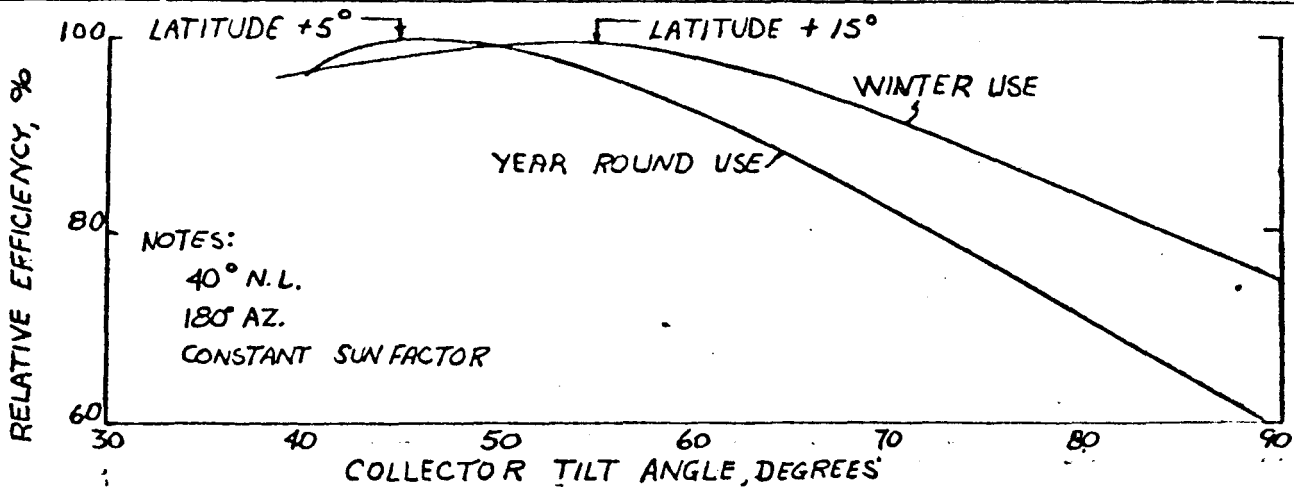

FIGURE 7 EFFECT OF COLLECTOR TILT ON SYSTEM EFFICIENCY

FERN ENGINEERING BUZZARDS BAY, MASSACHUSETTS U.S.A.	DRAWN	EFFECTS OF COLLECTOR AZIMUTH & TILT	
	APP'D		
	DATE		
	DWG. NO. FIGURES 5, 6 & 7	REV.	

Nevertheless, an optimum can be selected so that during the year an optimum amount can be collected. The calculated results shown in Figure 7 illustrate the effect of tilt on the solar insolation available to the collector. Different optimum tilts arise depending on the primary use of the collector; for space heating, the optimum tilt is approximately equal to the local latitude, plus 15 degrees, whereas when the use is primarily for heating hot water, the optimum tilt is approximately equal to the latitude plus 5 degrees.

The optimum tilt is also dependent on climatic conditions, and system design details. Weather data on the monthly percentages of solar insolation available allowing for cloudiness can be used to refine the results given in Figure 7. System influences on the optimum tilt are varied and involve the demand profile, storage capacity and method of control. In spite of all the complicated factors relating system performance to tilt angle, experience has shown that the simple guideline of latitude plus 5 degrees for space and DHW heating represents a practical choice for the tilt angle.

Cost factors enter in retrofit situations and departures from the optimum tilt and azimuth that will reduce the collected energy may be acceptable because the collector attachment to a roof can have a substantial cost impact.

Shading

Shading of the collector will result in a direct loss of solar energy collection otherwise possible. Critical shading angles tend to occur at the winter solstice, December 21, when the sun elevation above the horizon is lowest. The angle between the sun and the local horizontal (ground) at noon on December 21 is called the altitude and is:
Winter Solstice Noon Altitude = $66.5 - \text{latitude}$, (in degrees).

For example, if your latitude is 42 degrees, the altitude is 24.5 degrees and a typical shading situation is shown in Figure 8. During the winter solstice, the sun is southeast of the collector at 9 am and southwest of the collector at 3 pm and the altitude at these times is about one-half the altitude at noon. If a shading problem is suspected, a plot plan, south, east and west elevation sketches of the site should be studied to ensure a minimal amount of shading.

At the summer solstice, June 21, the sun is high in the sky and the noon altitude is ; Summer Solstice Noon Altitude = $113.5 - \text{latitude (in degrees)}$.

For example, if your latitude is 42 degrees, the noon altitude is 71.5 degrees and a potential shading situation is shown in Figure 9 .

Duct Runs

The length of duct runs should be minimized to avoid excessive thermal losses and installation costs. The flow rate through the duct should not exceed 600 FPM. Insulating this duct with 4 inches of fiberglass is recommended.

An additional factor is the gage and choice of duct material. The minimum gage required should be used. When the collector is started, the cold ducts absorb heat so when the collector is shut off the heat stored is lost , so it is important to use minimum acceptable gages.

The use of aluminum ducting would reduce the duct loss by 40% and is recommended when the benefit can be derived at a reasonable cost. On cloudy days, the ducts are repeatedly heated and cooled and the importance of minimizing the overall duct weight is even more pronounced.

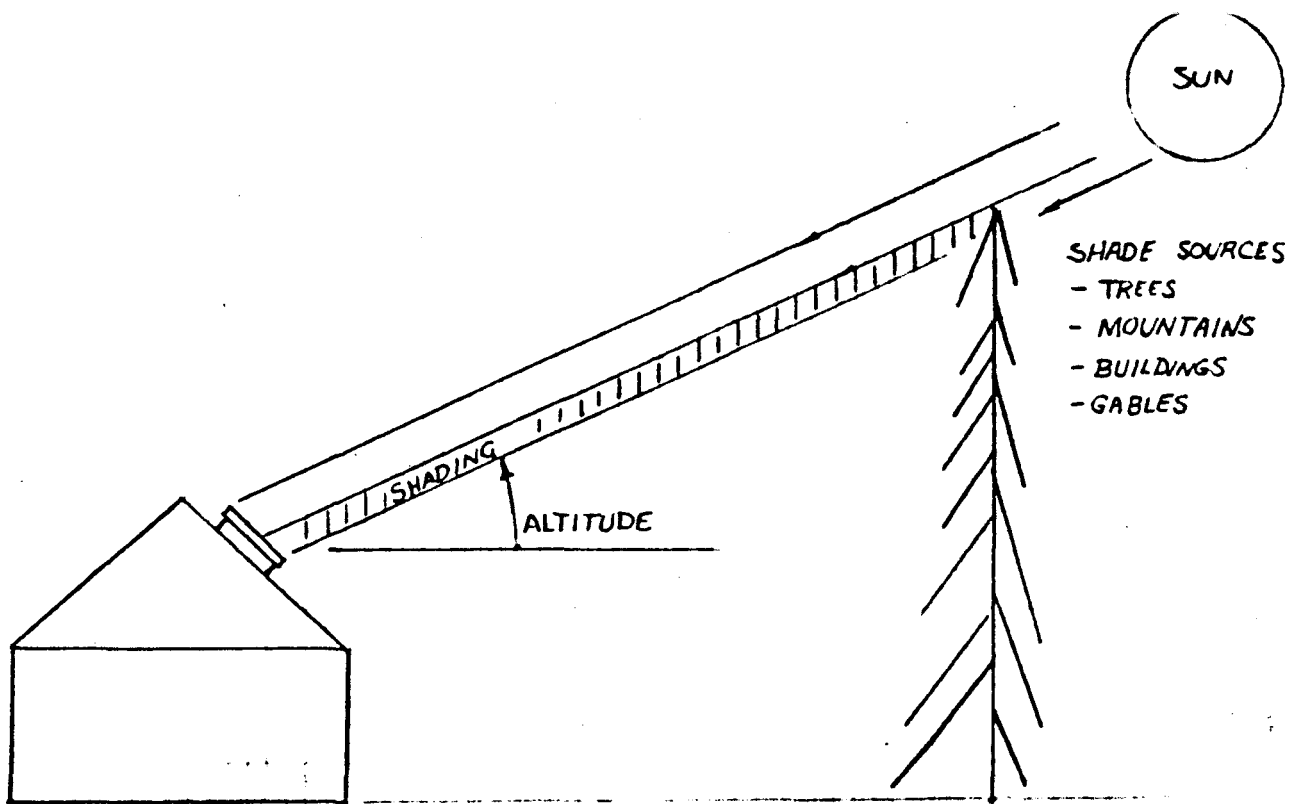

FIGURE 8 SHADOW AT WINTER SOLSTICE

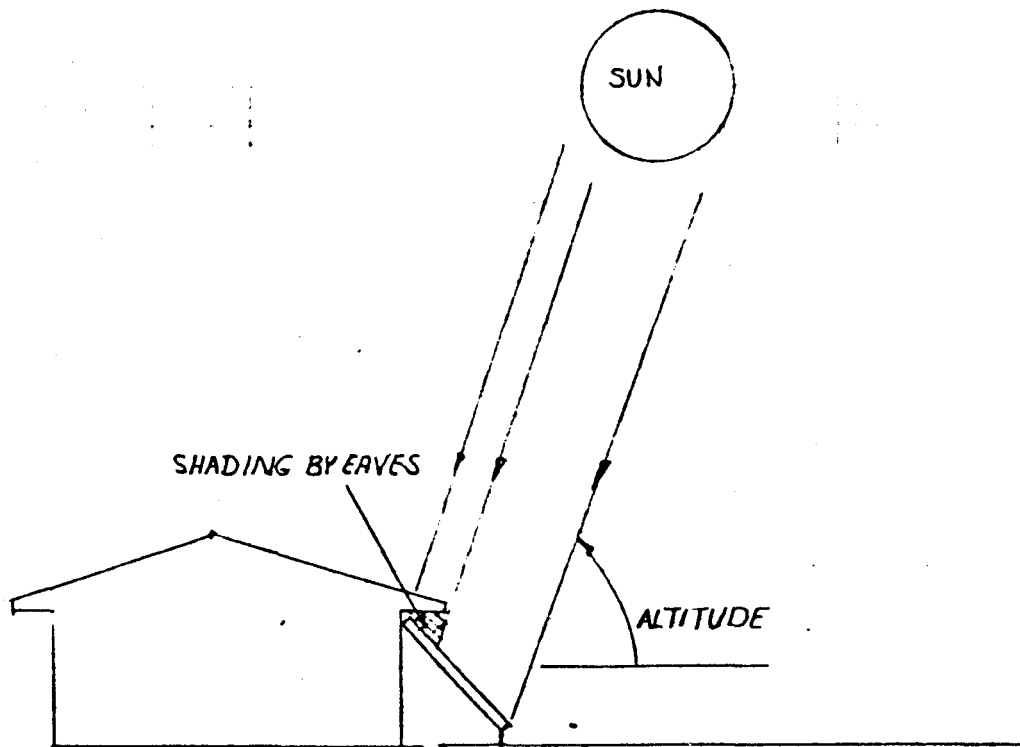

FIGURE 9 SHADOW AT SUMMER SOLSTICE

FERN ENGINEERING BUZZARDS BAY, MASSACHUSETTS U.S.A.	DRAWN	SHADOW CONSIDERATIONS	
	APP'D		
	DATE	DWG. NO. FIGURES 8 & 9	

The number of elbows should be minimized to avoid excessive pressure drops. Mitered elbows should not be used unless turning vanes are provided. Full radius elbows are recommended. The pressure drop per 100 ft of duct is .05 inches of water. For each elbow the loss is .006 inches of water.

Duct temperatures will not exceed 250°F in continuous operation. Duct joints should be joined with rivets or sheet metal screws so that the joint integrity will be maintained during thermal expansions and contractions.

Pressure Drops

Collectors	.15 inches of water @ 5 Collectors in series, 300 CFM, 60 SCFM/ Collector ($2SCFM/Ft_c^2$)
Collection Inlet	.02 inches of water @ 600 FPM inlet
Collector Outlet	.02 inches of water @ 600 FPM outlet
Straight Duct	.05 inches of water Per 100 Ft. @ 600 FPM
Full Radius	
Duct Elbows	.006 inches of water Per Elbow @ 600 FPM
ETM Mode 1	.35 inches of water @ 600 SCFM
Mode 2	.22 inches of water @ 600 SCFM
Mode 3	.48 inches of water @ 600 SCFM

Note: $Ft_c^2 = \text{Collector Area, Ft}^2$

INSTALLATION ARRANGEMENTS

Various retrofit or new installation arrangements are shown in Figure 10.

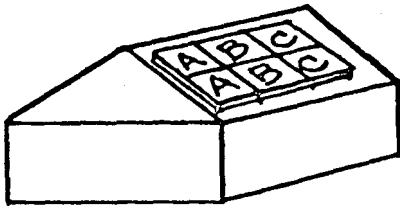

CAPE

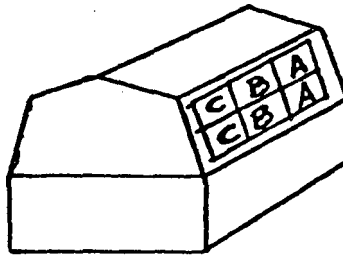

GAMBREL

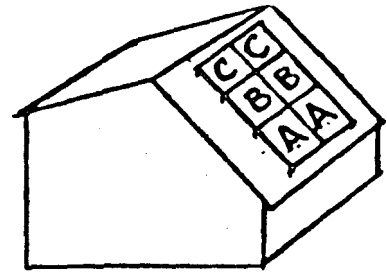

SALT BOX

10a ROOF MOUNTED , ELEVATED OR INTEGRATED

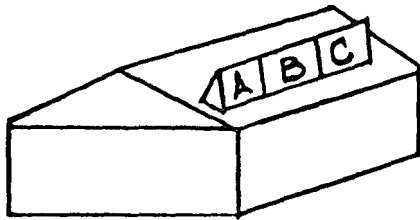

RANCH

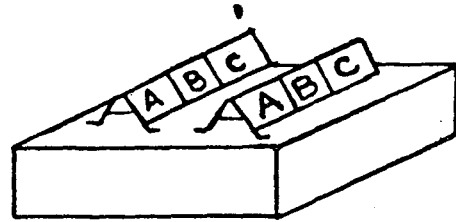

FLAT ROOF

10b ROOF MOUNTED , OPTIMUM TILT

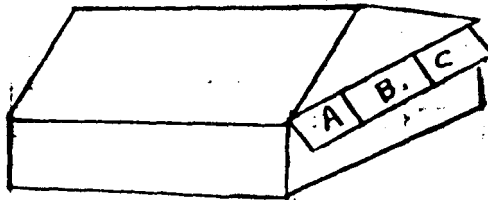

10c WALL MOUNTED

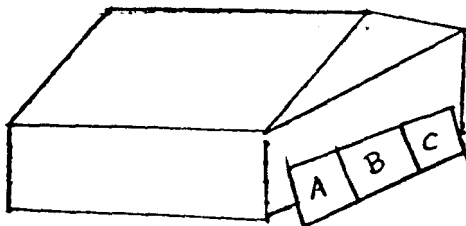

10d GROUND MOUNTED

FERN ENGINEERING
BUZZARDS BAY, MASSACHUSETTS
U.S.A.

DRAWN

APP'D

DATE

COLLECTOR
ARRANGEMENTS

DWG. NO. FIGURE 10

REV.



ROOF INSTALLATIONS

Three types of roof installations are shown in Figure 11.

Solafern can supply all the accessory hardware cited in Figure 11.

INSTALLATION SEQUENCE

The four step sequence of installation is shown in Figure 12.

The length of collector run should be selected to avoid roof overhangs, and generally located to achieve an architecturally pleasing appearance and/or to avoid shading. Specifically, the inlet and outlet collars located on 16" centers should span a rafter so the penetrations required do not interfere with a rafter. The center line between the inlet and outlet is 18 inches from the end of the Collector.

The first bracket should be located on the first rafter

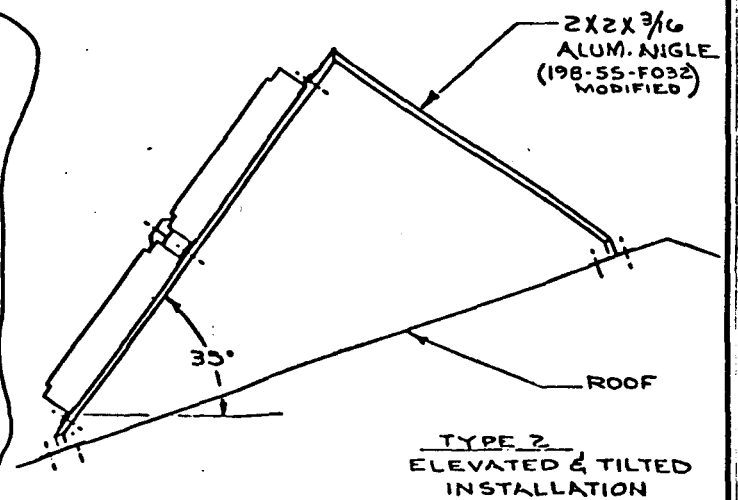
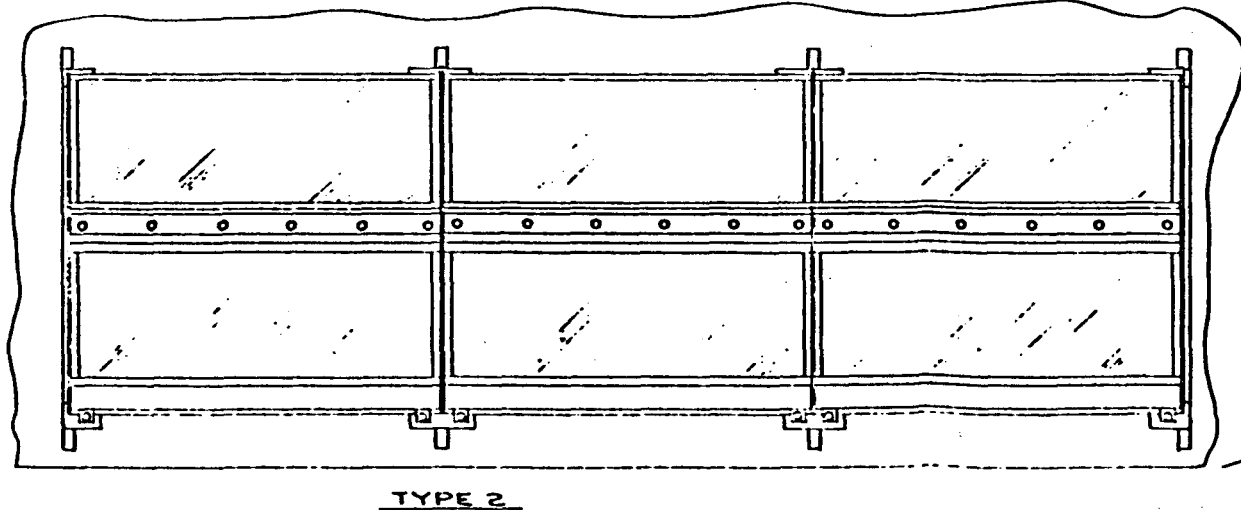
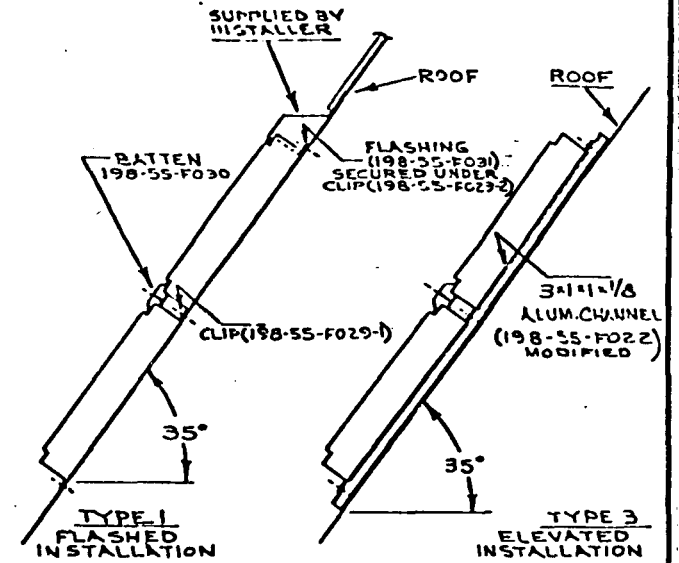
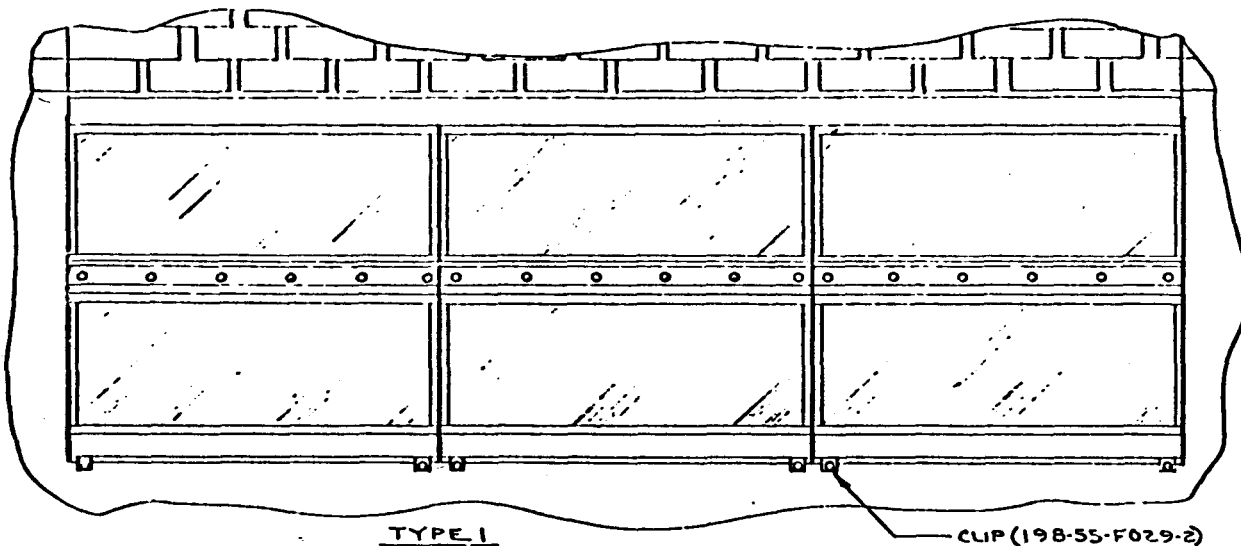

2-9

NO.	DATE	REVISIONS	DWG. NO.	REFERENCE DRAWINGS

N.A.S.A. FERN ENGINEERING BUZZARDS BAY, MASSACHUSETTS U.S.A.		DRAWN DDL APP'D DATE 11/18-77	INSTALLATION TYPES (COLLECTOR TO ROOF) (FIGURE 11) DWG. NO. 198-55-F033	
--	--	---	---	--

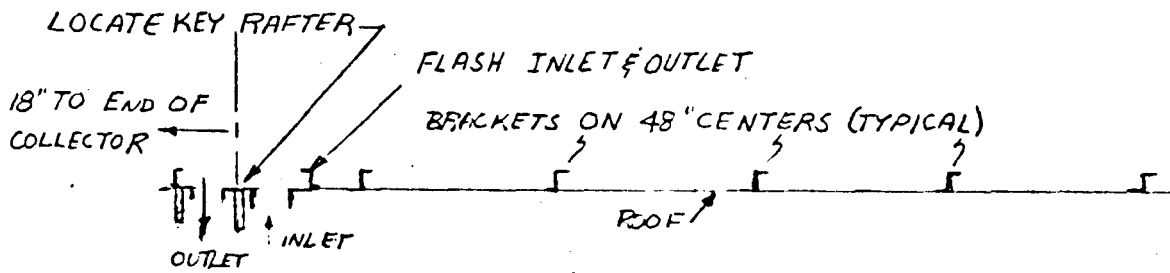

STEP 1 INSTALL BRACKETS & MAKE ROOF PENETRATIONS

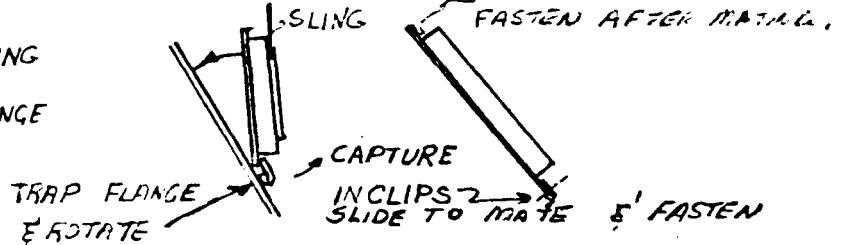
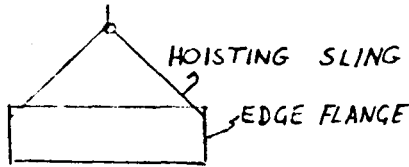

STEP 2 RAISE COLLECTORS FOR HIGHEST ROW AND CAPTURE ON ROOF

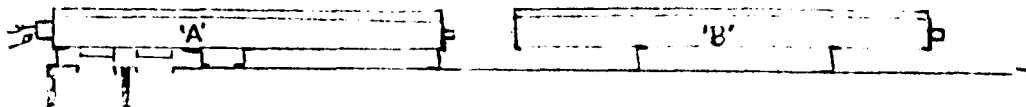

STEP 3 LOCATE AND BOLT DOWN 'A' COLLECTOR

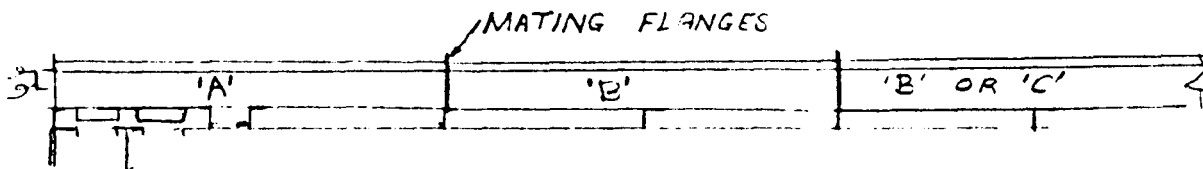

APPLY SCHLINT GASKET TO MATING FLANGES
 INSTALL SILICONE GASKET
 SLIDE 'B' TO MATE 'A' FLANGE
 BOLT FLANGES
 REPEAT FOR ADDITIONAL COLLECTORS

STEP 4 INSTALL 'B' & 'C' COLLECTORS TO COMPLETE ROW

FERN ENGINEERING BUZZARDS BAY, MASSACHUSETTS U.S.A.	DRAWN	INSTALLATION SEQUENCE		
	APP'D			DWG. NO. FIGURE 12
	DATE			

outboard to the outlet connection. The bracket locations should be selected to provide at least two per collector. The brackets are to be lagged to the rafters with at least 4-1/4" x 3" lag screws. The foot of the bracket should be pre-coated with roofing cement, the lag bolts overcoated with roofing cement and the edges of the bracket filleted with roofing cement. Additional precautions shall be taken as required to ensure that there will be no water penetration into the dwelling.

A weather-tight roof curbing for the duct penetration through the roof must be provided. This enclosure must be flashed to the roof and cemented to prohibit water penetration.

The collectors can be raised to roof via a sling as shown in Figure 12. If a simple hoisting sling is used, each leg should be 8 feet and an anchor type hook used to connect the 3/4" hoisting holes located in the collector flanges. If a close hookup is desired, the use of an 8 foot strong-back with short cables and anchor hooks can be used. The attachment brackets are provided with Clips at the lower ends. Lowering the collector mounting edge into the clip and rotating the collector until it is flat allows the collector to be slid up to the adjacent collector for mating. Lubricating the clip eliminates galling while sliding the collector. After the collectors have been mated, the flanges bolted and sealed, the collectors are bolted to the brackets on both the upper and lower mounting flanges.

All the collectors in a row can be brought to the roof and captured via 2 Clips each.

With all the collectors raised to the roof, the assembly of the joints is begun.

The "A" collector is bolted to the supports. Before butting the "B" and "A" collector bases together, a liquid gasket such as Dow Corning 781 is applied.

Foam tape, 1/8" x 1" with adhesive on two sides is installed on the lower edge of each mating face. The collectors are slid together, engaging the ducts and butting the flanges.

A flexible sealant such as DC 781 is used to caulk the flange joint as required.

If two "B" collectors are being used, attaching the 2nd "B" collector to the first is done identically as described above.

Closing the "C" collector is done in the same manner as a "B" collector. Use flexible sealant as required to weatherproof the joint.

The joint between collectors should be flashed by folding a strip of aluminum foil with adhesive backing over the joint prior to bolting.

A 1/2" thin-wall box wrench is recommended for tightening the bolted flanges.

Weep holes are recommended to be located at each corner of the lowest edge of each collector, and are nominally 1/8" diameter.

3. ETM INSTALLATION

A typical ETM installation is shown in Figure 13. The ETM is located to minimize duct runs and to interface conveniently with the warm air furnace. The ETM is shipped in two parts; the blower and motor assembly and the flow control assembly. The flow control assembly is 31" x 29" x 46" high, and contains 2 damper motors, 4 dampers, connecting ducting, and the heat exchanger. The blower and motor assembly is 22" x 17" and 22" high. The blower and motor assembly has a weather cover, which can be removed to check and adjust the drive belt, motor and sheaves.

ETM Mounting

The two assemblies should be uncrated, inspected for damage and located in the approximate area where the ETM is intended to be placed. The two assemblies are joined by sliding the blower assembly into place so that the rectangular discharge duct and round inlet ducts line up. The discharge connection is an overlapping sheet metal fit which can be joined by either lifting the flow control assembly and lowering it on to the blower discharge, or by folding out one side of the mating ETM duct and refolding once the blower is in place. The discharge connection is finished with a flexible sealant as DC 781 and/or fastening with sheet metal screws. The round duct connection is made with the drawband provided.

The foundation support for the ETM assembly should be as rigid as possible.

Both assemblies should be fastened down to the foundation. The base should be shimmed if the foundation is uneven to avoid distorting the supporting frame.

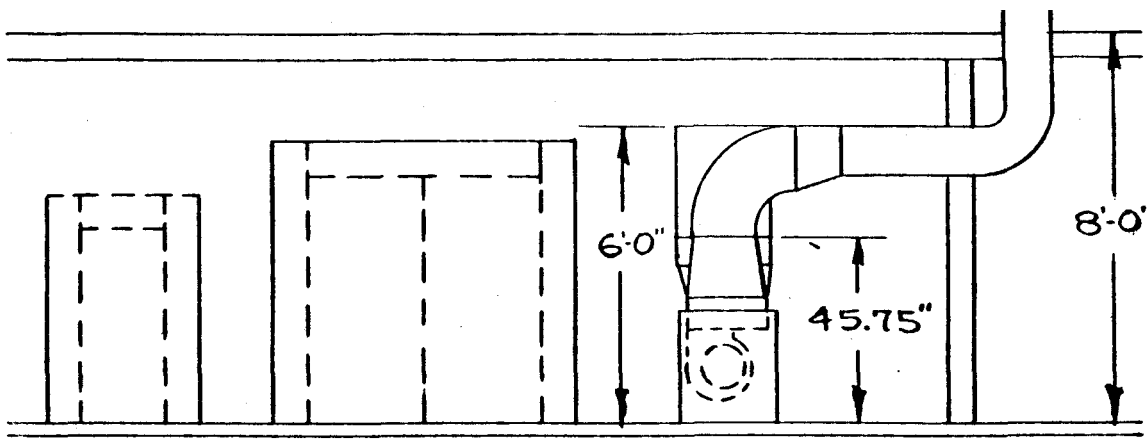

VIEW "A-A"

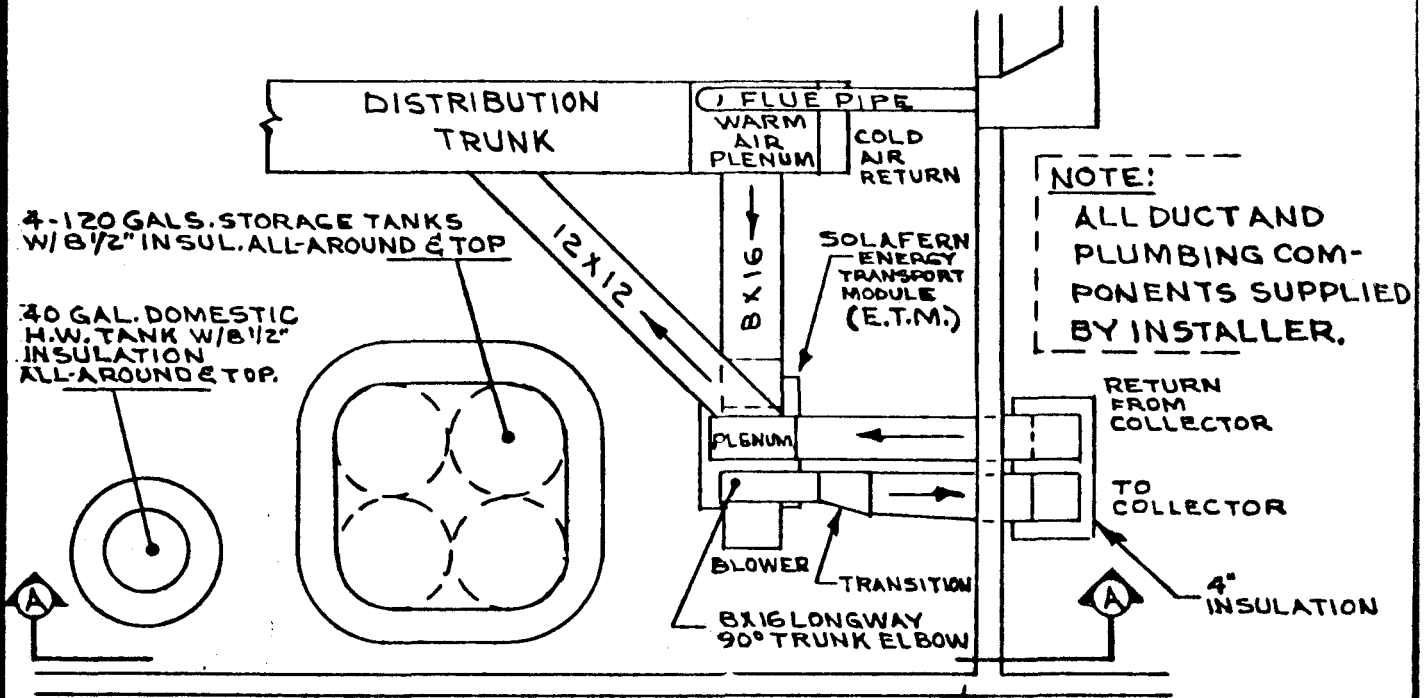

BASEMENT PLAN VIEW
SCALE: 1/4" = 1.0'

NOTE:
ALL DUCT AND
PLUMBING COM-
PONENTS SUPPLIED
BY INSTALLER.

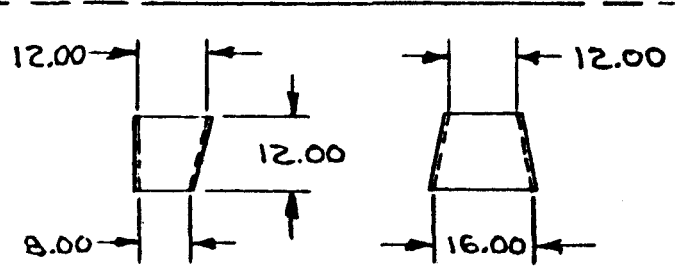
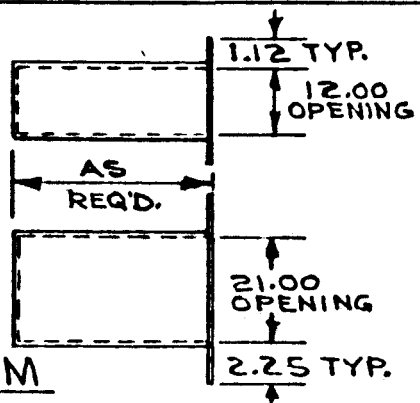

TRANSITION

MATERIAL: 28 GA. (.0187 THK.) GALV. STEEL

PLENUM

SOLAFERN LTD.
BUZZARDS BAY, MASSACHUSETTS
U.S.A.

DRAWN
D.O.L.
APP'D
[Signature]
DATE
8-3-77

TYPICAL E.T.M.
INSTALLATION

DWG. NO. 724-55-002

REV.



ETM Duct Connections

The ETM inlet air duct carrying the house return air has an 8" x 16" connection, using drive cleats on the short side and "S" cleats on the long side. The ETM discharge air duct carrying air to the collector has an 8" x 16" connection using drive cleats on the short side and "S" cleats on the long side. A plenum is mounted above the heat exchanger. A plenum detail is shown in Figure 13. The height of the plenum is dependent on the head room available and so the plenum is not supplied. The plenum has an inlet connection carrying air from the collector and an outlet connection carrying air to the main distribution trunk; these connections should not be on the same side of the plenum, but can be either on opposite or adjacent sides. The duct connections to the ETM should avoid mitered 90° joints whenever possible.

ETM Piping Connections

The heat exchanger connections are 1/2" F.P.T. There are two circuits which are to be connected in parallel using 3/4" piping. A temperature and pressure relief valve should be installed between the heat exchanger and any shut-off valve with a vent pipe conforming to local codes. Unions and gate valves should be located for convenient installation. A dirt leg should be provided for occasional maintenance.

ETM Insulation

After the ETM is installed, it must be insulated with at least 4 inches of fiberglass insulation rated to 250° F. Board type insulations are recommended in the vicinity of the damper linkages; the damper motors are to be left exposed. The blower bearings and motor are to be protected by insulating the baffle separating the blower and motor enclosures.

4. ELECTRICAL

The electrical schematic is shown in Figure 14. A control enclosure is provided containing all the additional relays necessary to accommodate the solar system operating modes and furnace interfaces. The state of each damper is:

<u>Mode</u>	D 1	D 2	D 3	D 4
1. Direct solar heating	open	closed	closed	open
2. Heating by stored energy	open	closed	open	closed
3. Energy storage	closed	open	closed	open

The thermostat settings are:

Room Thermostat	Adjustable
Collector TSTAT	Close on use to 100°F, open on fall to 90°F.
Storage TSTAT	Close on rise to 100°F, open on fall to 90°F.
Diff. TSTAT	Open on rise to 180°F, close on fall to 170°F. Close on DT + 20°F, open on DT = + 10°F.
Furnace Discharge TSTAT	Opens on rise to 110°F, closes on fall to 90°F.

Auxiliary Furnace Interfaces

The interfaces between the auxiliary furnace and the solar system are:

- 1) Separate circuit breakers and emergency shut-offs.
- 2) 1st stage of room thermostat powered by 24 V ETM transformer.
- 3) 2nd stage of room thermostat powered by 24 V furnace transformer.
- 4) Activation of stage 2 of the room thermostat starts the furnace burner via the burner relay control.

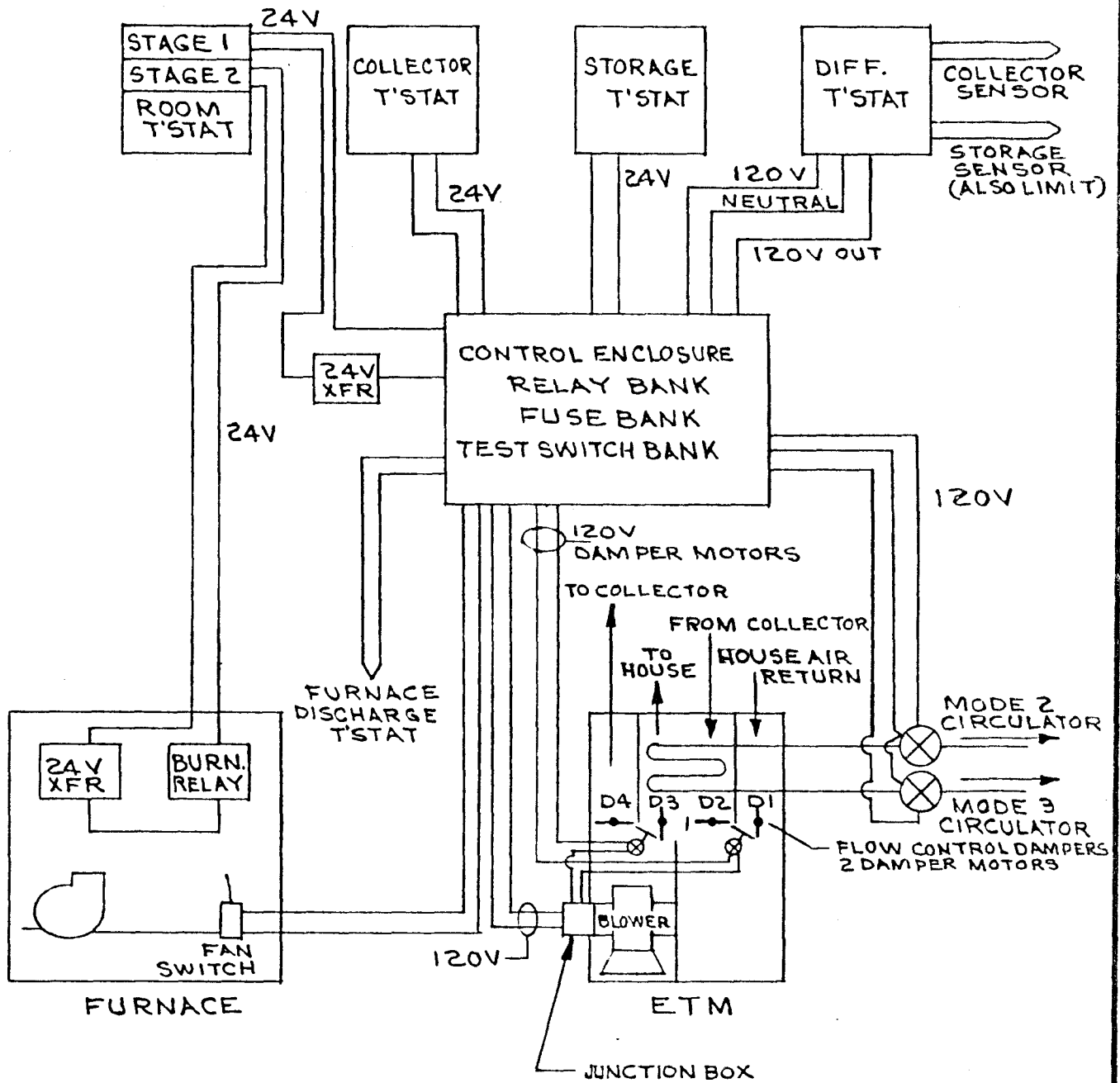

FERN ENGINEERING
BUZZARDS BAY, MASSACHUSETTS
U.S.A.

DRAWN

APP'D

DATE

**ELECTRICAL
SCHEMATIC**

DWG. NO. **FIGURE 14**

REV.



- 5) Furnace discharge TSTAT opens on rise inhibiting Modes 1 and 2 so that simultaneous solar and furnace space heating cannot occur; this is done to avoid excessive delivery temperatures.
- 6) Activation of stage 1 of the room thermostat in Mode 1, the direct solar space heating mode, causes both the furnace and collector fans to start. The furnace fan switch is in parallel with a relay in the ETM so it is powered in Mode 1 and Mode 2.

Space Heating Control Logic

Whenever there is a demand for space heating, priority is given to using available solar energy first; if the available solar energy cannot sustain the demand then the auxiliary furnace burner is started. Solar energy can be delivered either directly, or from thermal energy. Relays control the solar energy supply in the following way:

- 1) Priority is given to direct space heating by solar, so if stage 1 of the room thermostat closes, and if the collector thermostat is closed, then the solar and furnace fans are powered. Dampers divert building air to collector.
- 2) If stage 1 of the room thermostat is closed, the collector thermostat is open, and the storage thermostat is closed, then the solar and furnace fans are powered. Dampers divert building air to heat exchangers.
- 3) If stage 1 of the room thermostat closes and both the collector

and storage thermostat are closed, preference is given to the direct heating mode by locking out the storage delivery mode.

- 4) If neither the collector or storage thermostats are closed, no solar heat will be delivered and as the room temperature falls, stage 2 of the room thermostat is closed starting the furnace burner.

Circulator Control Logic

Two circulator pumps are used to circulate water bi-directionally between the storage tanks and the heat exchanger. When stage 1 of the room thermostat is closed, the collector thermostat is open and the storage thermostat is closed, then the stored solar energy is used to supply space heating. A circulator is started to circulate water from the upper level of the tanks (to take account of stratification) to the heat exchanger.

A circulator is required to reverse the flow when heat is stored. The differential thermostat controls the storage mode in that collector air temperature must be at least 20° F above the storage temperature to enable the storage mode to start.

Electrical Connections

The electrical connections are shown in Figure 15.

1. ETM

The ETM requires 120 V ac for the blower and the two damper motors. The ETM

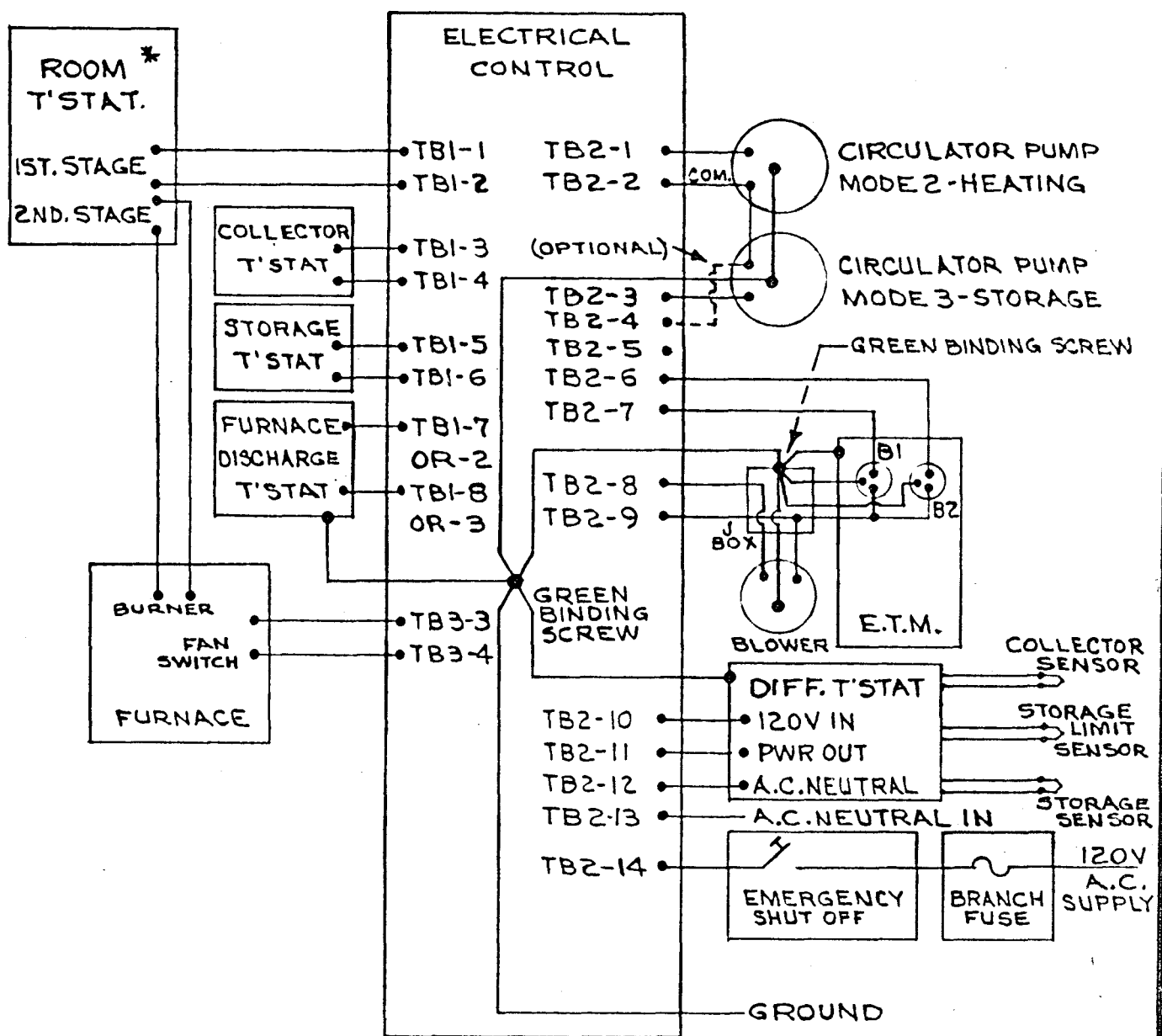

* USE ROOM THERMOSTAT WITH ISOLATED CONTACTS TO PREVENT INTERCONNECTION OF CLASS II OUTPUTS.

WIRING DIAGRAM

A	11-14-77	ADDED 'STORAGE LIMIT SENSOR'	REVISION
NO.	DATE		
FERN ENGINEERING BUZZARDS BAY, MASSACHUSETTS U.S.A.		DRAWN APP'D DATE	WIRING DIAGRAM DWG. NO. FIGURE 15 REV. A



frame must be grounded. Conduit must be used to connect the ETM to the control panel as shown in Figure 15. The terminal board connectors are labelled inside the controller enclosure. The blower and damper rotations must be verified. The 120 V blower connection is TB2-8; the inlet damper motor 120 V connection is TB2-6; the outlet damper motor 120 V connection is TB2-7. The ETM neutral connection is TB2-9.

2. Two-stage Thermostat

Disconnect the present thermostat and install the two-stage thermostat. Stage 2 is connected to the furnace oil burner control exactly in the same way as the single stage thermostat. Stage 1 is connected to terminals TB-1 and TB1-2 located in the electrical enclosure.

3. Collector Thermostat

The collector sensor assembly shown in Figure 16 consists of the collector thermostat, a differential thermostat thermistor and a weather-tight enclosure. The sensor assembly is installed at the three-quarter point of the collector slant height in an "A" type collector. The collector thermostat is a hermetically sealed, high quality, snap acting thermostat, with a high temperature rating. The thermistor has a copper housing with a hole punched in it for direct attachment. The sensors are located in the air stream behind the absorber just upstream of the final return bend prior to discharge from the collector. The location of the sensor allows for temperature stratification prior to start-up and causes all control functions to be based on the discharge temperature of the air from the collector.

The collector thermostat is connected to terminals TB1-3 and TB1-4 in the electrical enclosure.

MOISTURE PROOF BELL BOY W/LUGS
NO. 270-L, UNIVERSAL E
BELL-BLANK WEATHER PROOF
COVER PLATE

SENSORS SUB ASSY.

CEMENT

THERMOSTAT

SENSOR

15.00

6.50

NOTES:

1. DRILL .640 DIA. HOLE THRU ENCLOSURE PLATE, GLAZING FRAME END CAP AND 180° RETURN BEND.
2. INSTALL SENSOR ASSY. TO ENCLOSURE PLATE WITH (2) NO. 8 SHEET METAL SCREWS X 5/8 LONG.
3. ASSEMBLY TO BE CAULKED WEATHERTIGHT.

COLLECTOR SENSOR ASSY.
FIGURE 16

4. Storage Thermostat

The storage thermostat is installed at one storage tank as shown in the piping diagram. It is to be connected between points TB1-5 and TB1-6.

5. Differential Thermostat

Probes for differential thermostat are located at the top of one storage tank and at one type "A" collector. The bolt-on probe in the collector is to be connected to the differential controller. The immersion sensor on the storage tank is to be connected to the differential controller. The differential thermostat power connections are shown in Figure 15.

6. Circulator Pumps

Interface with the circulator pumps is accomplished by connecting the pump motor wires as follows: TB2-2 is common; TB2-1 for mode 2 circulator; TB2-3 for mode 3 circulator.

7. Furnace

Interface with furnace is accomplished by connecting stage 2 of the room thermostat to the furnace thermostat connections. A furnace discharge thermostat is installed in the discharge duct and connected to TB1-7 and TB1-8.

8. Power Supply Branch Circuit

Power supply branch circuit connection may be made to the same "side" of circuit as furnace branch circuit if convenient. Provide a chassis ground. Connect AC neutral to TB2-13 and line, 120 V 60 cps to TB2-14. The line current should be run through an EMERGENCY shut-off, which should be located adjacent to furnace emergency shut-off. The circuit for the solar heating system should carry a 15 amp circuit breaker.

5. PIPING

A typical piping schematic is shown in Figure 17. The storage tanks should be located convenient to the ETM. The following equipment is to be installed:

- 1) Storage tanks, as required (1.5 gal/ft² collector), connect in parallel so DHW draw is from top.
- 2) Two centrifugal circulators, storage mode draws from bottom; heating mode draws from top.
- 3) Pressure/temperature relief valves for ETM heat exchanger to prevent damage if gate valves left closed.
- 4) Vacuum relief valves to prevent cross-connections.
- 5) Expansion tank, pre-pressurized to 40 PSI; 100 PSI limit.
- 6) Pressure regulator to 40 PSI if municipal supply pressure is higher.
- 7) A backflow preventer to avoid heating cold water and/or losing stored energy.
- 8) A mixing valve to prevent over temperature on DHW.
- 9) Gate valves to isolate components for convenient maintenance.
- 10) Provide a bypass to the DHW heater for maintenance of the storage system.

The connections between tanks and other fixed end points must allow for thermal expansion. The tanks are insulated with an R = 15 batt on the sides and top; no additional insulation is used on the bottom, relying on the insulative qualities of the water to limit the heat loss. The piping and fittings must be insulated with 3/4" thick sleeve-type insulation. The air ducting should be insulated with at least 4-inches of fiberglass insulation rated to 250° F.

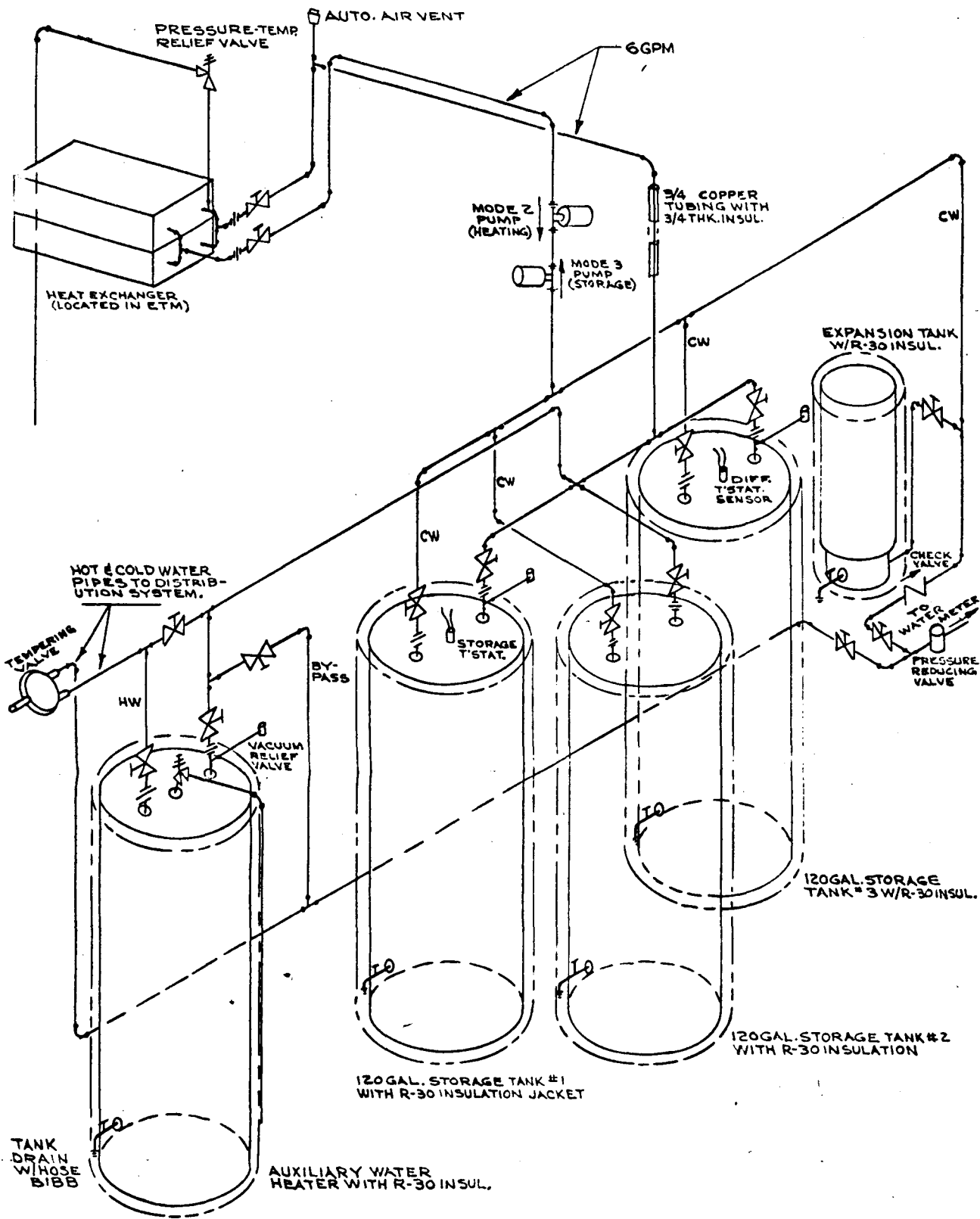

NOTES:

1. INSTALLATION MUST ALLOW FOR THERMAL EXPANSION OF PIPING.
2. 1/2" COPPER TUBING UNLESS OTHERWISE SPECIFIED.
3. EXTEND DRAIN AND FITTING CONNECTIONS BEYOND INSULATION.

PIPING SCHEMATIC
FIGURE 17

6. EQUIPMENT REQUIRED

SOLAFERN ETM - Model 600: Includes blower, blower motor, heat exchanger, 4-dampers, 2-damper motors. One required for nominal flow rate of 600 CFM.

SOLAFERN CONTROL PANEL: Includes 24 V transformer, protection fuses, differential TSTAT, circuits, control relay bank prewired, test switches. One required per system.

SOLAFERN SOLAR COLLECTOR TYPE A: Collector used to start a row, includes inlet and outlet duct attachment collars, end plate and internal flow baffles. One required per row.

SOLAFERN SOLAR COLLECTOR TYPE B: Interconnecting collectors within a row, open ends, as required by row length.

SOLAFERN SOLAR COLLECTOR TYPE C: Collector used to terminate a row, includes internal flow baffle and end plate.

SOLAFERN COLLECTOR SENSOR PACKAGE: Assembly of all weather electrical box, collector insertion probe with thermostat and differential sensor attached. One required per system.

CIRCULATOR PUMP: 6 GPM @ 8 ft. head integral pump assembly.

EXPANSION TANK: Size to accept expansion over temperature range 50° F to 180° F and operating pressure 40 to 80 PSI. Pressurized bladder-type approved for DHW. Relief valve setting 100 PSI. Supplied as either 1 or 2 tanks depending on storage size. AMTROL type ST EXTROL or equal.

MIXING VALVE: Bronze body, temperature range 110° - 170° F, rating 6 GPM, 1/2" sweat fittings, AMTROL Model 420 or equal.

AIR VENT: Pressure range 0-100 PSI, fast venting positive shut-off AMTROL Model 701 or equal. Vertical mount at system high point.

PRESSURE RELIEF VALVE: Set for 100 PSI.

CHECK VALVE: Brass, 1" NPT, TEEL 2 x 612 or equal.

VACUUM BREAK: One per tank to avoid cross-contamination; allows for draining of tanks.

PRESSURE REDUCER: Drops cold water supply pressure to 40 PSI, no bypass. Used to maintain pressure control between 40-80 PSI allowing for expansion.

COLLECTOR BOLTING HARDWARE: Seven 5/16" diameter 18 THD 7/8"

lg. stainless bolts per joint.

INSTALLATION CLIPS: Optional, to assist installation and to clamp collectors. Four required per collector.

BATTENS: Optional for collector - roof type installations,

MOUNTING BRACKETS: Optional, custom made to order for roof or ground mounting.

STORAGE THERMOSTAT: Snap acting thermostat set to close on rise to 100° F and open on fall to 90° F; hermetically sealed to strap on storage outlet piping.

STORAGE TANKS: 120 gallon approved for DHW; SEPCO CS - 120-N or equal.



Solafern, Ltd.

COMPONENT ORDER FORM

CUSTOMER:

ADDRESS:

JOB NO.

DATE:

P. O. Box M
536 MacArthur Boulevard
Bourne, Massachusetts 02532
Tel. (617) 563-7181
TWX 710-391-1771 FERNENG BUZB

QTY.	ITEM	STOCK NO.
	COLLECTORS TYPE "A"	198-55-A 001
	COLLECTORS TYPE "B"	198-55-B 001
	COLLECTORS TYPE "C"	198-55-C 001
	COLLECTOR MOUNTING CLIP	198-55-F 029-1
	COLLECTOR MOUNTING CLIP	198-55-F 029-2
	COLLECTOR MOUNTING BATTEN	198-55-F 030
	COLLECTOR MOUNTING FLASHING	198-55-F 031
	ROOF CURBING (Roof pitch same as Collector tilt)	198-55-D 018
	ROOF CURBING (20° Roof slant)	198-55-D 020
	CONTROL PANEL	198-55-G 007
	E.T.M. ASSEMBLY	198-55-G 006
	COLLECTOR SENSORS ASSEMBLY	198-55-F 019
	STORAGE THERMOSTAT	ELMWOOD 198-30-D 001-2
	DIFFERENTIAL THERMOSTAT	DELTA-T MODEL 400 (Modified)
	FURNACE THERMOSTAT	HONEYWELL L 4064 -B 1469
	CIRCULATOR PUMP W/ 1" DIA. FLANGES	GRAINGER 1P -903 & 8X489
	2-STAGE THERMOSTAT/ W BASE	HONEYWELL 872-F-1019/Q672-C-1003
	STORAGE TANK (120 gals.)	SEPCO C 1205 - 0

INSTALLATION HARDWARE

	POLYURETHANE FOAM TAPE (Flange Gasket Tape)	3M TYPE 4008 1" Wide X 1/8" Thick
	BOLTS, HEX HEAD S/S W Nuts (Collector joining)	5/16 - 18 thd. x 3/4 long
	COLLECTOR BATTEN TAPE	3M PRODUCT 1202-T - 1/3 Thick
	BATTEN MOUNTING HARDWARE	TEKS; 6 of MB/w, 8 of PLYMETAL

7. PHYSICAL DATA

Collector

Type:	Two-pass air heating.
Dimensions:	51.88 in. x 97.41 in. x 10.12 in.
Weight:	191 lbs.
Cover System:	1 sheet 7/32 inch Tempered Low Iron "Crystal" Glass. Silicone "U" gasket, weep holes, dessicant, insulated.
Absorber Plate:	Black chrome, selective coating on textured copper foil.
Insulation:	Non-combustible, fiberglass selected for minimal outgassing.
Flow Rate:	2 scfm/sq. ft. collector, nominal.
Frame:	Aluminum, removable cover.
Installation:	Gang to form continuous rows, bolted joints.

Storage

Type:	Pressurized, potable hot water tanks.
Capacity:	120 gal. modules, 1-to-2 gal/sq. ft. collector.
Dimensions:	28 in. diameter x 62 in. high.
Insulation:	R= 30
Weight:	5500 lbs. each, empty: 1550 lbs. full.
Rating:	Tested to 300 psi; operational to 80 psi.
Expansion:	Expansion tank with bladder, operating range 40-80 psi.

Auxiliary Heating

Type: Any warm air furnace or water-to-air heat pump.

Output: Sized for design load.

Domestic Hot Water

Type: Draw preheated water from storage/any auxiliary type suitable.

Output: Sized for needs.

Safety: Tempering valve.

Controls

Logic: Based on temperatures and temperature differences.

Sensor Types: Two-stage room thermostat—first stage closes at settable temperature. Second stage closes at 3°F (adjustable) below set temperature.

Collector thermostat - Closes on rise to 100°F .

- Opens on fall to 90°F .

Storage Thermostat - Closes on rise to 100°F .

- Opens on fall to 90°F .

Differential Controller—Closes on collector to storage difference rise to $+20^{\circ}\text{F}$.

- Opens on collector to storage difference fall to $+10^{\circ}\text{F}$.

- Opens on storage rise to 180°F , regardless of above.

- Resets on storage fall to 170°F .

8. SELECTION PROCEDURE

The f - chart method described in "HUD Intermediate Minimum Property Standards Supplement", 1977 Edition, (HUD Doc. 4930.2) for Solar Heating and Domestic Hot Water Systems is in widespread use. Sufficient climatic information is contained in the HUD 4930.2 document to evaluate the effects of insulation, collector size and storage size. An example calculation is presented in the following worksheets for an installation in Lansing, Michigan.

The f-chart method is applied to the Solafern, Ltd. air system with water storage, by using the liquid system methodology described in 4930.2; all the necessary system parameters are given in the example calculation.

WORKSHEET A PROJECT DATA

PROJECT NASA, E. LANSING MICHIGAN

Location Latitude = $42^{\circ} 44'$

Building Heating and/or Hot Water Load

Design Heat Loss Rate, $Q_d/\Delta t_d$ = 260 Btu/h $^{\circ}$ F

Winter Design Temperature (97 1/2%), t_w = 0 $^{\circ}$ F

Average Hot Water Consumption (may vary on a monthly basis) = 80 gal/day

Average Cold Water Supply (main) Temp., t_m (may vary on a monthly basis) = 50 $^{\circ}$ F

Hot Water Supply Temp., t_s = 140 $^{\circ}$ F

Collector Subsystem Data

Collector Type: SELECTIVE,
 Selective or non-selective, no. cover plates _____

Collector Area, A_c = 240 ft 2

Tilt Angle = 43 $^{\circ}$

Azimuth Angle = 0 $^{\circ}$

Collector Shading (av. 1 month of Dec.) = 0 %

Collector Efficiency Data
 (from manufacture): $F_R(\tau\alpha)_n$ = .69
 $F_R U_L$ = .55 Btu/h \cdot ft 2 \cdot $^{\circ}$ F

Reference Temp. Basis: t_{in} , $\frac{t_{in} + t_{out}}{2}$, t_{out}

Fluid:

Composition: AIR

Specific Heat, c_p = Btu/lb \cdot $^{\circ}$ F

Specific Gravity (if applicable) = lb/lb

Volumetric Flow Rate = gal/min or ft 3 /min

Storage Subsystem Data

Volume = 360 (gal) or ft 3

Storage Medium WATER

Specific Heat, c_p = 1 Btu/lb \cdot $^{\circ}$ F

Specific Gravity/or Density = 1 lb/lb or lb/ft 3

Circulation Loop Volumetric Flow Rate = 6 (gal/min) or ft 3 /min

Collector/Storage Heat Exchange Effectiveness, ϵ_{cs} = .833

Hot Water Preheat Storage Volume = 80 gal

Load Subsystem Data

Load Heat Exchanger Effectiveness, ϵ_L = .833

Supply Loop Volumetric Flow Rate = 6 gal/min

Building Air Supply Volumetric Flow Rate = 1000 ft 3 /min

5

WORKSHEET B FRACTION OF TOTAL HEATING LOAD SUPPLIED BY SOLAR ENERGY, F_{Annual} PROJECT _____

4930.2

	1	2	3	4	5
Month	Tot. No. Htg. Load $\frac{6 L}{10 \text{ Btu/mo.}}$	System Parameter D_1	System Parameter D_2	Solar Fraction/ no. f	Actual Solar en/mo $\frac{6 E}{10 \text{ Btu/mo.}}$
Jan.	7.83	.37	2.1	.22	1.72
Feb.	6.99	.63	2.1	.45	3.15
March	6.52	.91	2.4	.62	4.04
April	4.47	1.21	3.1	.76	3.40
May	3.06	2.24	4.3	.90	2.75
June	2.09	3.31	5.7	.90	1.88
July	1.86	3.41	6.4	.90	1.67
Aug.	1.86	3.72	6.6	.90	1.67
Sept.	2.28	2.78	5.5	.90	2.05
Oct.	3.63	1.50	3.8	.84	3.05
Nov.	5.49	.71	2.7	.45	2.47
Dec.	7.30	.43	2.2	.28	2.04

911-A

$L_{tot} = 53.38$

$E_{tot} = 29.89$

$F_{Annual} = \frac{E_{tot}}{L_{tot}} = \frac{29.89}{53.38} = .56$

1. From Worksheet D
2. From Worksheet C
3. From Worksheet C
4. From "f chart"
5. $E = f \times L$

2.2
2.49
3.15

5

WORKSHEET C SYSTEM PERFORMANCE PARAMETERS D_1, D_2

PROJECT _____

A-117

Month	1 Tot. Monthly Radiation on Tilt Surf. S Btu/(Mo-ft ²)	2 Total Heating Load L MA Btu/Mo.	S/L	3 D_1	4 Mo. Av. Day Time Temp. t_o °F	$212 - t_o$ °F	Tot. Hrs in Mo. Δ time hr.	5 K_3	6 D_2
Jan.	20460	7.83	.00261	.371	26	186	744	1	2.1
Feb.	31248	6.99	.00447	.634	26.4	186	672	1	2.1
March	41726	6.52	.0064	.91	35.7	176	744	1	2.4
April	37860	4.47	.0085	1.21	48.4	164	720	1	3.1
May	48360	3.06	.0158	2.24	59.8	152	744	1	4.3
June	48810	2.09	.0233	3.31	70.3	142	720	1	5.7
July	50809	1.86	.0273	3.41	74.5	137	744	1	6.4
Aug.	48918	1.86	.0272	3.72	72.4	140	744	1	6.6
Sept.	44940	2.28	.0196	2.78	65.0	147	720	1	5.5
Oct.	38657	3.63	.0106	1.50	53.5	158	744	1	3.8
Nov.	22140	5.49	.0040	.71	40.0	172	720	1	2.7
Dec.	21793	7.3	.0030	.43	29.0	183	744	1	2.2

- $A_c = 240$ Given data
- $F_R'(\bar{\tau}_0) = .61$ Worksheet F
- $F_R' U_L = .49$ worksheet F
- $K_1 = 1$ Worksheet G
- $K_2 = 1$ Worksheet G
- $K_4 = .97$ Worksheet G

1. From Worksheet E
2. From Worksheet D

3. $D_1 = \left[\frac{A_c F_R'(\bar{\tau}_0) S}{L} \right] \times K_4 = (D_1 \text{ prod.}) \frac{S}{L} =$
 Where: $D_1 \text{ prod.} = \left[A_c F_R'(\bar{\tau}_0) \right] \times K_4 = 240 \times .61 \times .97 = 142$

4. From Sec. 5 Table A-4
5. From Table A-14 and Worksheet G

6. $D_2 = \left[\frac{A_c F_R' U_L (t_{ref} - t_o) \Delta \text{time}}{L} \right] \times K_1 \times K_2 \times K_3 = (D_2 \text{ prod.}) \left[\frac{(212 - t_o) \Delta \text{time}}{L} \right] \times K_3 =$
 Where: $D_2 \text{ prod.} = (A_c F_R' U_L) \times K_1 \times K_2 = 240 \times .49 = 117.6$

WORKSHEET D HEATING AND/OR DOMESTIC HOT WATER LOAD, L

PROJECT _____

4930.2

Month	1 Monthly Degree Days DD °F-days	2 Monthly Space Htg Load Qs Btu/Mo. MM BTU	3 No. of Days/ Mo. N	4 Vol. of DHW Used/Mo. Gal./Mo.	5 Temp. Water Main Sup. t_m °F	6 DHW Temp. Rise $t_s - t_m$ °F	7 Monthly DHW Load Qw Btu/Mo. MM BTU	8 Total Heating Load L Btu/Mo. MM BTU
Jan.	1194	5.97	31	2480	50	90	1.86	7.83
Feb.	1061	5.31	28	2240	50	90	1.68	6.99
March	933	4.66	31	2480	50	90	1.86	6.52
April	534	2.67	30	2400	50	90	1.80	4.47
May	229	1.20	31	2480	50	90	1.86	3.06
June	57	.29	30	2400	50	90	1.80	2.09
July	0	0	31	2480	50	90	1.86	1.86
Aug.	0	0	31	2480	50	90	1.86	1.86
Sept.	96	.48	30	2400	50	90	1.80	2.28
Oct.	353	1.77	31	2480	50	90	1.86	3.63
Nov.	738	3.69	30	2400	50	90	1.80	5.49
Dec.	1088	5.44	31	2480	50	90	1.86	7.3

$q_d = \text{_____ Btu/h}$
 (Given data or calculate from Manual J or equivalent.)

$\Delta t_d = 70 - t_v$
 $= 70 - \text{_____}$
 Where: $t_v = 97 \frac{1}{2}\%$ winter design temperature
 (From ASHRAE Fundamentals, Table A-3, section 5 or known weather data.)

70° = indoor design temperature

$UA = \frac{q_d}{\Delta t_d} = 260 \text{ BTU/hr.}^\circ\text{F}$

$t_s = \text{_____}$

811-A

- From ASHRAE Systems, Climatic Atlas or Table A-3, section 5.
- $Q_s = (PF)(24)(UA)(\text{Degree Day}) = \frac{.8 \times 24 \times 2.60}{\text{_____}} \times (\text{Degree Day}) =$
 Where: PF = 0.75 or more appropriate value.
- (Vol/day) (no. days/mo.) = $\frac{80}{\text{_____}}$ (gal./day) (no. days/mo.)
- May be constant or may vary.
- $Q_w = (\text{vol. of water}) \times 8.33 \times 1 \times (t_s - t_m)$.
- $L = Q_s + Q_w$

6

WORKSHEET E TOTAL MONTHLY SOLAR RADIATION AVAILABLE, S

PROJECT _____

	1	2	3	4	5		6
Month	Horizontal Insolation \bar{I}_H Btu/(Day·ft ²)	Extra-terrestrial Insolation I_0 Btu/(Day·ft ²)	Ratio Horizontal to Extra-terrestrial K_t	Ratio Horizontal to Tilt \bar{K}	Monthly Avg. Daily Rad. on Tilt Surf. \bar{I}_T Btu/(Day·ft ²)	No. of Days in Month N	Tot. Monthly Radiation on Tilt Surf. S Btu/(Mo·ft ²)
Jan.	425.8	1190	.35	1.55	660	31	20460
Feb.	739.1	1661	.431	1.51	1116	28	31248
March	1086	2276	.456	1.24	1346	31	41726
April	1249.8	2955	.406	1.01	1262	30	37860
May	1732.8	3431	.489	.90	1560	31	48360
June	1914	3636	.508	.85	1627	30	48810
July	1884.5	3535	.514	.87	1639	31	50809
Aug.	1627.7	3136	.498	.97	1578	31	48918
Sept.	1303.3	2510	.493	1.15	1498	30	44940
Oct.	891.5	1839	.456	1.40	1247	31	38657
Nov.	473.1	806	.333	1.56	738	30	22140
Dec.	379.7	1040	.349	1.85	703	31	21793

- From Table A-4 or Fig. A-29 section 5, or known data.
- From Table A-5 section 5, used only for eq. 11.
- From Table A-4 section 5, or eq. 11.
- From Table A-6 section 5, latitude (θ) = _____°, with collector tilt (θ) = _____°, and latitude - tilt = _____°.
- From eq. 12, $\bar{I}_T = (\bar{I}_H)(\bar{K})$.
- From eq. 13, $S = (\bar{I}_T)(N)$.

611-V

9. GUIDE SPECIFICATIONS

1. Functional Specifications

- 1.1 The system will provide space and hot water heating.
- 1.2 The system shall be capable of the following operating modes:
 - 1) Direct space heating by solar energy
 - 2) Space heating by stored solar energy
 - 3) Storage of solar energy
 - 4) Space heating by auxiliary heating subsystem
 - 5) DHW heating from storage
 - 6) DHW heating by auxiliary hot water heater
- 1.3 The system shall use air heating collectors and heated water for energy storage.
- 1.4 The system operation shall be fully automatic.

2. Performance Specifications

- 2.1 The system performance shall be unaffected by periods of no-flow in the collector due to reduced demand, power outages, or during installation.
- 2.2 The solar collector shall have an efficiency greater than 50% when the average air temperature is: $\bar{T} = .4 I + T_a$, where I = solar insolation in $\text{Btu}/\text{Ft}^2\text{-hr}$ and T_a is the ambient temperature in degrees F, for example, for $I = 250$, $T_a = 40$, $\bar{T} = 140^\circ \text{F}$.
- 2.3 The system thermal losses due to ducting shall not exceed 2.5% of solar energy collected.
- 2.4 The storage loss shall not exceed 2% of solar energy collected in 8 hours.
- 2.5 The collector fan energy shall not exceed 2% of the solar energy collected on a clear day.
- 2.6 The circulator fan energy shall not exceed 2% of the solar energy collected on a clear day.

3. Collector Subsystems

- 3.1 A single glazing of low-iron crystal clear glass shall be used.
- 3.2 The absorber shall be a selective coating of black chrome applied to a copper substrate. The absorber shall be textured to enhance heat transfer.
- 3.3 The rear closure insulated shall be of high temperature fiberglass type which has very low outgassing.
- 3.4 The collector frame shall be of aluminum construction.
- 3.5 The glazing cover shall be removeable from the front of the collector without disturbing the adjacent collectors.
- 3.6 The collectors shall be of two-pass design so the inlet and outlet are on the same end of a row.
- 3.7 The collector shall be manufactured by SOLAFERN, LTD.

4. Energy Transport Subsystem

- 4.1 The energy transport subsystem shall be prepackaged into an energy transport module (ETM) including the collector blower, operating mode control dampers and damper motors.
- 4.2 The flow rating of the ETM shall be 600 CFM.
- 4.3 A pressure reducer shall be used if the municipal line pressure is greater than 40 PSI.
- 4.4 An airvent valve shall be provided to vent trapped air.
- 4.5 A pressure relief valve shall be provided at the heat exchanger and expansion tanks set for 100 PSI.

4.6 A reversible circulation pump shall be provided to store and extract solar energy.

5. Storage Subsystem

5.1 The storage subsystem shall be pressurized water in tanks approved for DHW.

5.2 An expansion tank shall be provided to maintain the water pressure between 40 and 80 PSI.

5.3 A check valve (back flow preventer) shall be provided so expanded water shall not re-enter the municipal water line.

5.4 Provision shall be made for thermal expansion of piping.

6. Control Subsystem

6.1 A control subsystem shall be provided for automatic control of the system in all 4 modes.

6.2 24 volt control circuits shall be used.

6.3 A two-stage room thermostat shall be used.

6.4 The control subsystem shall be manufactured by SOLAFERN, LTD.

7. Limited Warranty

SOLAFERN, LTD. warrants the solar system components against defects in workmanship or materials under normal use for one year from the date of installation.

The collector warranty is for 5 years, except for glass breakage. The warranty covers parts only. In order to obtain service, the purchaser obtains a service warranty from the installer.