

c.2



Lawrence Berkeley Laboratory

UNIVERSITY OF CALIFORNIA

Accelerator & Fusion Research Division

Presented at the Workshop on the Physics of Linear
Colliders, Capri, Italy, June 13-17, 1988

Status of LBL/LLNL FEL Research for Two Beam Accelerator Applications

D.B. Hopkins and A.M. Sessler

November 1988

LIBRARY AND DOCUMENTS SECTION
MAY 17 1989

TWO-WEEK LOAN COPY

*This is a Library Circulating Copy
which may be borrowed for two weeks.*

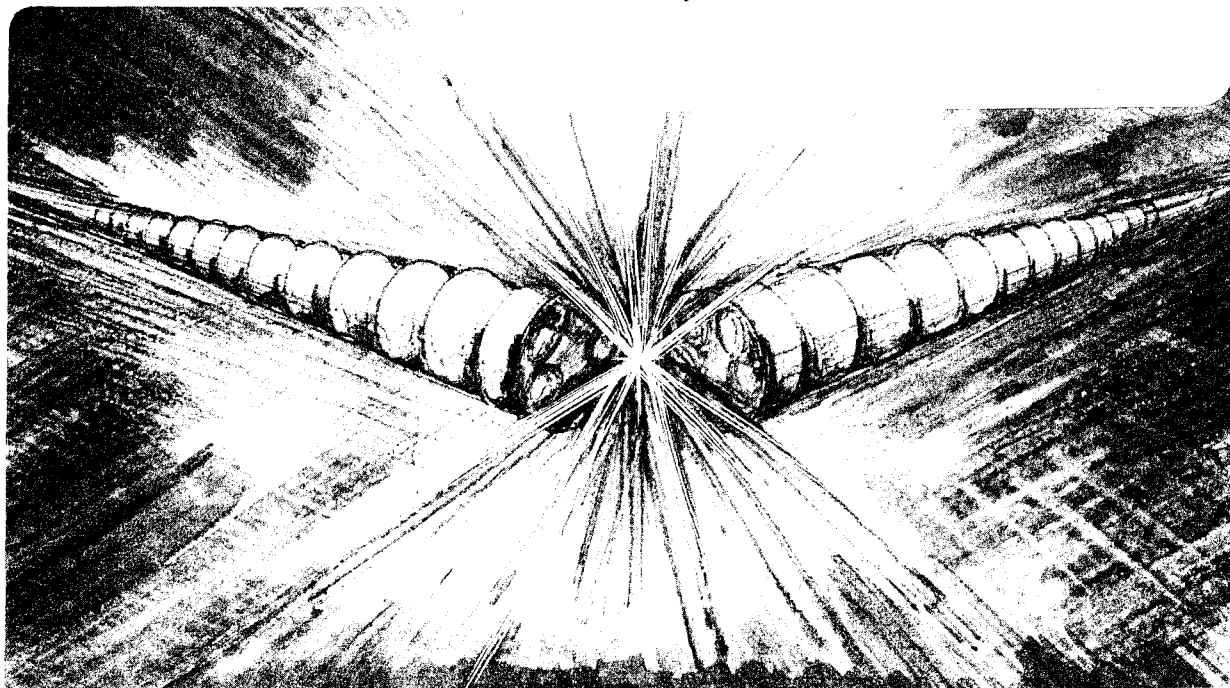

c.2

**STATUS OF LBL/LLNL FEL RESEARCH FOR
TWO BEAM ACCELERATOR APPLICATIONS***

D. B. Hopkins and A. M. Sessler
Accelerator and Fusion Research Division
Lawrence Berkeley Laboratory
University of California
1 Cyclotron Road
Berkeley, California 94720

November, 1988

*Work performed under the auspices of the U.S. Department of Energy by the
Lawrence Berkeley Laboratory under contract No. DE-AC03-76SF00098.

STATUS OF LBL/LLNL FEL RESEARCH FOR TWO BEAM ACCELERATOR APPLICATIONS*

D. B. Hopkins and A. M. Sessler
Lawrence Berkeley Laboratory
Berkeley, California 94720

November, 1988

Abstract

For this workshop, we review the status of free electron laser (FEL) research being conducted at LBL and LLNL as part of a broader program of research on two beam accelerators (TBAs). We discuss measurements made on high power 35 and 138 GHz FELs and their problem areas. Experience with 35 GHz accelerator section fabrication is summarized. Induction accelerator - driven FELs for use as power sources for high-gradient accelerators are discussed, along with preliminary cost estimates for this type of power source. Finally, a promising new version of an FEL/TBA is discussed.

LBL/LLNL FEL Research

Figure 1 shows the principal elements of an FEL-driven two-beam accelerator. The TBA has been discussed in detail elsewhere.^{1,2}

In collaboration with LLNL, our FEL experimental research program got underway in 1982 with the construction of the Electron Laser Facility (ELF) at LLNL.³ This was a 35 GHz FEL consisting of the ~ 3.5 MeV, 1 KA, 50 ns ETA electron accelerator and a 3m (later 4m) long pulsed electromagnetic wiggler which had been designed and fabricated at LBL. Simultaneously, a 2-D FEL simulation computer code, named FRED, was developed at LLNL.⁴

The performance of ELF has been summarized in other papers.⁵⁻⁷ Highlights are presented in Table 1. The phase stability ($\pm 20^\circ$) quoted in the table refers to measured variations in output phase compared to that of the magnetron driver. It can be explained by shot-to-shot beam energy variations of 1.5%.⁷ The wiggler field strength was tapered on ELF (i.e. reduced as the beam traversed the length of the wiggler) in order to maintain beam-wave synchronism, increasing output power and efficiency. Figure 2 clearly indicates the advantage of this procedure.

*Work performed under the auspices of the U.S. Department of Energy by the Lawrence Berkeley Laboratory under contract No. DE-AC03-76SF00098.

The Two Beam Accelerator (TBA) consists of a high power microwave FEL and a high gradient linac

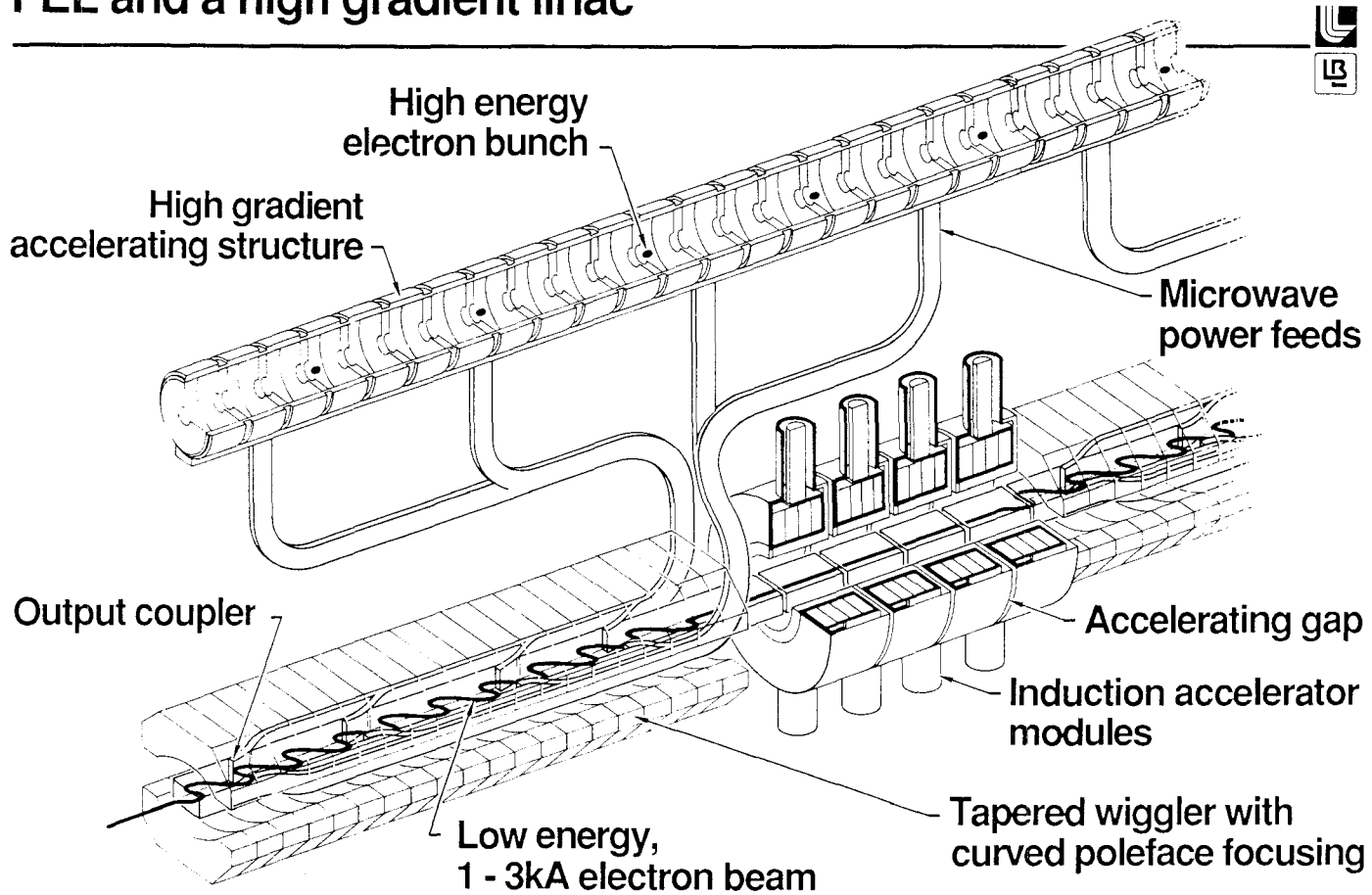

-2-

90-F-1086-2386

Figure 1. FEL/TBA Configuration

XBL 873-898

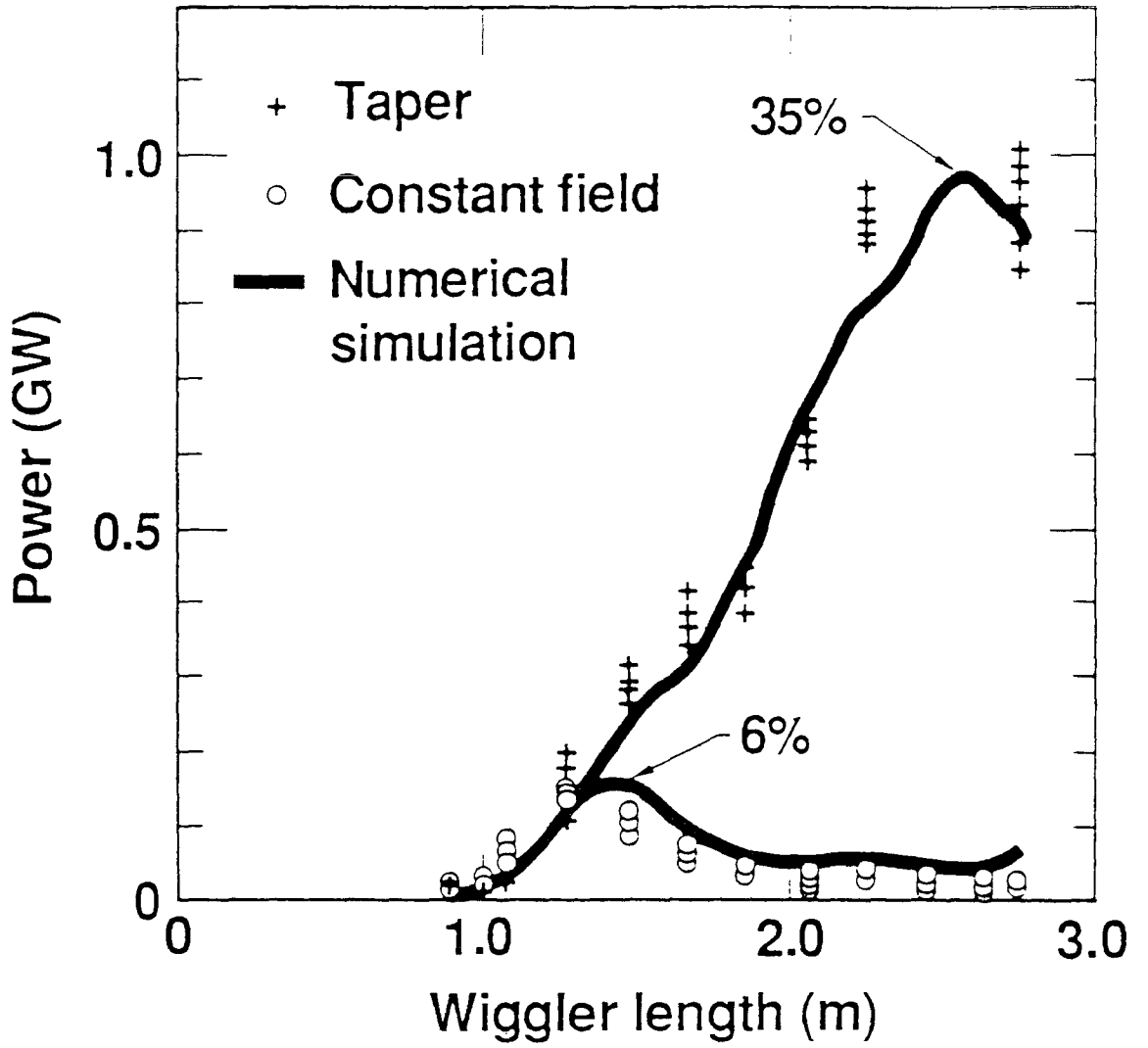

XBL 8811-3858

Figure 2. 35 GHz ELF Output Power

TABLE 1

ELF 34.6 GHz Performance Highlights with Tapered Wiggler

Peak power output in TE ₀₁ mode	1.8 GW
Input power	30 kW
Gain	35dB/m, 48dB total
Bandwidth, 1dB	12%
Pulse width	~ 15 ns
Repetition rate	0.5 Hz
Beam energy	3.6 MeV
Beam current	1.1 kA
Beam brightness	2x10 ⁴ A/(cm-rad) ²
Beam to microwave power transfer efficiency	42%
Phase stability	~± 20°
Wiggler resonant field	3.8 kG
Wiggler length at saturation	1.4 m

ELF was also operated as a 138 GHz FEL using an Extended Interaction Oscillator (EIO) as a driver.⁸ Highlights of its performance are shown in Table 2 and Figure 3. Although its operating frequency is higher than that required for presently-envisioned accelerator applications (but of great interest for ECRH plasma heating), this work is mentioned here as an example of recent FEL developmental progress.

TABLE 2

ELF 138 GHz Performance Highlights With Uniform Wiggler

Peak power output in TE ₀₁ mode	50-100 MW
Input power	30W
Gain	21dB/m, 65dB total
Wiggler resonant field	1.7 kG
Wiggler length at saturation	3.4m

Preliminary attempts to increase the power output by tapering the wiggler field were unsuccessful. Simulation showed that this problem manifests itself at higher frequencies and is due to space charge effects which degrade the electron trapping efficiency. Subsequent analysis⁹ has shown that tapering can be effective in increasing the output power if electrons are first brought to FEL synchronism before the tapering is begun. This can be achieved by slightly increasing the wiggler field at the beginning of tapering. An example of such a wiggler excitation profile is shown in Figure 4 (in this case for a 7 MeV, 250 GHz FEL). In these experiments, the measured output power level of relatively broadband spontaneous noise was comparable to that of the amplified 140 GHz signal. A new strategy for wiggler

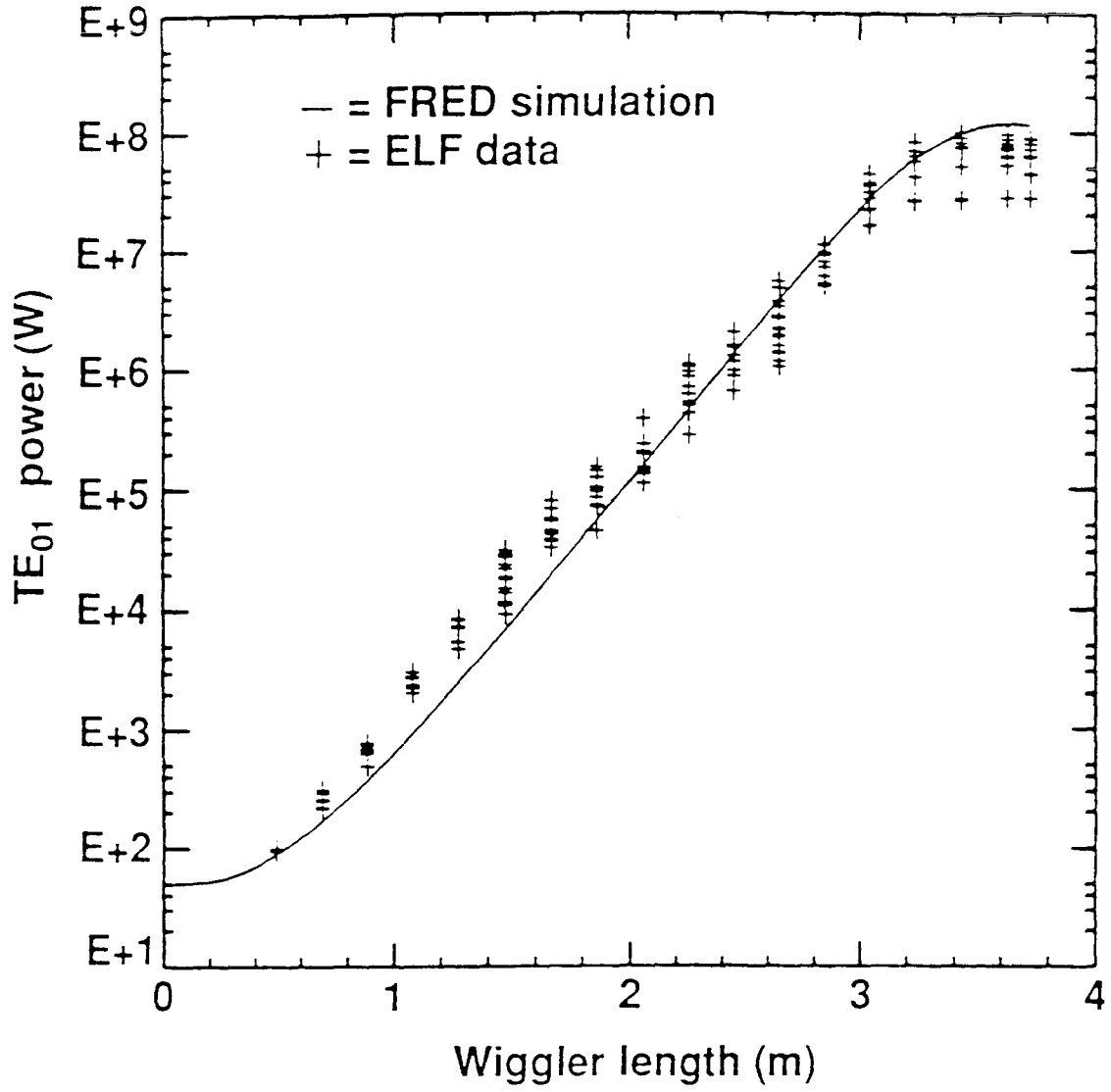

XBL 8811-3859

Figure 3. 138 GHz ELF Power Output

excitation and tapering has been developed¹⁰ which can reduce the output noise power to < 1% of the total FEL output.

FEL/TBA Problem Areas

For practical FEL-driven TBAs, a number of troublesome issues have recently been considered. Solutions have been found for some of these while others await further analytical and/or experimental treatment. The ultimate problem of achieving a design which has a reasonable cost is being more or less continuously addressed as our research progresses. This issue is discussed further in a later section of the paper.

Early on, wakefield effects in ~ 15-30 GHz high-gradient accelerator sections were thought to preclude their operation at interesting beam brightness levels for linear colliders under consideration. It has been shown¹¹, however, that the wakefields can be adequately reduced if three things are done. First, the beam apertures, i.e. iris diameters, must be increased about a factor of two over the dimensions arrived at by standard accelerator design procedures. This results in a reduction in shunt impedance, and therefore power efficiency, by an amount in the 30% range, a value considered acceptable. Second, there must be much more transverse beam focusing than in traditional linacs. This can be supplied by external quadrupoles, or, as has been suggested by W. Schnell, by rf in conjunction with elliptical (alternating) gaps. Third, as pioneered in the USSR¹² and extended by Bane at SLAC,¹³ an energy sweep along the bunch is required.

Another problem initially thought to be serious but later "solved" involves the large potential FEL gain at synchrotron frequency sidebands. This effect had been observed in an FEL oscillator by Tom Marshall at Columbia University. It is caused by the slippage of the electron beam parallel velocity, $v_{||}$, with respect to the microwave group velocity, v_g . Analysis shows¹⁴ that the synchrotron sideband power should be dramatically reduced if the FEL interaction waveguide size is chosen so as to make $v_{||} \approx v_g$. This approach has now been experimentally proven successful.¹⁴

In the TBA, as originally conceived, not all of the microwave power is removed from an FEL section. A significant amount of remaining power crosses the following beam-reacceleration gap, maintaining a sizeable rf bucket in which all of the electrons are "contained", thus establishing the proper phase in the next FEL amplifier. Several difficulties result from this arrangement for which no satisfactory solutions have yet been found. The first involves the requirement for efficient, single-mode transport of the rf (i.e. microwave) power across the gap. Experiments have shown that for a practical waveguide aperture and gap geometry, this loss is typically in the 10-25% range, a value that is probably unacceptably high.

A second difficulty involves another aspect of rf handling: the extraction of rf power from the FEL. The interaction waveguide is necessarily highly oversized for the operating wavelength. It is found that the usual techniques, e.g. directional

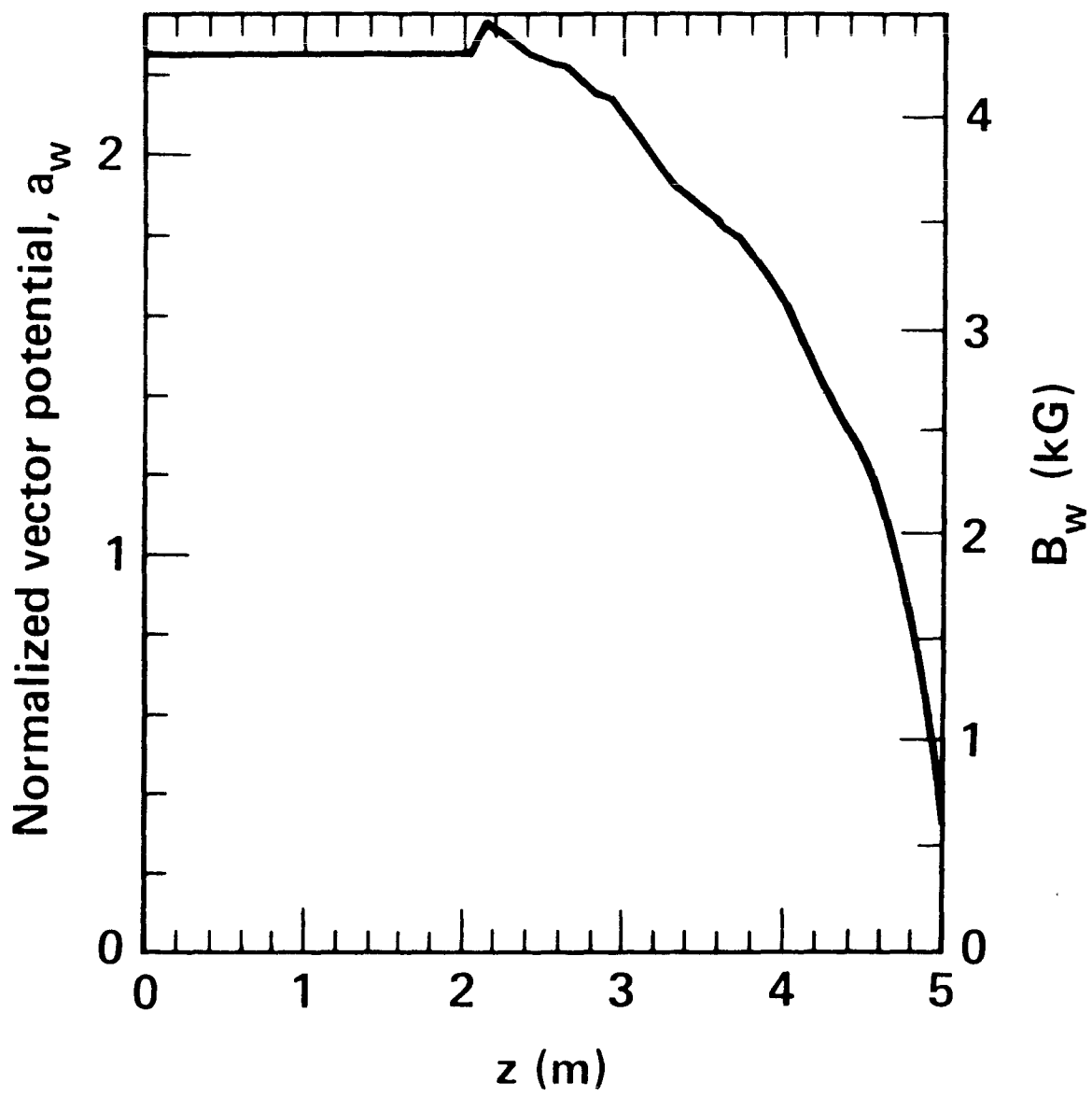

XBL 8811-3860

Figure 4. Wiggler magnetic field profile with Raman taper for an electron-beam energy of 7 MeV, plotted as a function of axial position.

coupling, are impractical and convert power into undesirable modes. We experimented at ELF with a type of coupler which has septa acting as "scoops" for extracting single-mode power.¹⁵ Low-level rf tests looked promising but when tested at high power at ELF, breakdown or electron loading problems developed at surprisingly low power levels, e.g. < 1 MW. A different approach is now under consideration. It is mentioned briefly in a later section, below, that discusses a new FEL/TBA version which avoids many of the problems discussed in this section.

A most serious problem with the original FEL/TBA configuration is its phase and amplitude sensitivity to errors in the wiggler magnetic field, beam energy and beam current.^{16,17} For practical machines, parameter stabilities of $\leq 0.1\%$ are required. The net effect is to limit realistic TBA section lengths to a few tens of meters, at best, with new beam injectors required at these intervals for "starting over". Feedback compensation schemes have been considered but appear to be impractical.

High Gradient Accelerator Fabrication

We turn now to the high gradient accelerator (HGA) portion of a TBA. Our group undertook a program to demonstrate the successful fabrication of HGA sections for 33-35 GHz operation and test them at ELF to determine their ultimate operating gradients. This work has been summarized elsewhere.^{15,18}

With a 7-cell, 34.6 GHz, traveling-wave, $2\pi/3$ mode, $v_p = c$, electroformed HGA test structure, we achieved an effective accelerating gradient of ~ 190 MV/m at an input power level of 3.1 MW. The value of peak field on surfaces was ~ 360 MV/m. This was without the usual benefit of rf conditioning since ELF operates at a rep-rate of only 0.5 Hz.

Next, a very-high quality, 34 cavity, 33.39 GHz traveling-wave, $2\pi/3$ mode, $v_p = c$ HGA was fabricated by the Haimson Research Corporation using precision machining and brazing techniques. Figure 5 shows a picture of this 10 cm-long, vacuum-jacketed assembly attached to 90° tapered input/output couplers, waveguide tapers and vacuum pumpout. Before this could be tested, ELF was disassembled so that the ETA accelerator could be rebuilt. The HGA is now being maintained at a 10^{-9} Torr vacuum level awaiting a 50-100 MW 33 GHz power source for testing.

While the machined and brazed (M&B) HGA was being fabricated, we also proceeded with the development of an electroformed HGA. This was to be identical to the M&B HGA to permit comparison testing of the two. While we did not fully complete this development, we did determine an acceptable electroplating procedure and also work out precision machining techniques which successfully produced a number of aluminum mandrels. Dimensional tolerances of ± 1.25 μm were achieved. Figure 6 shows a prototype electroformed HGA and a section of a mandrel alongside a cm scale.

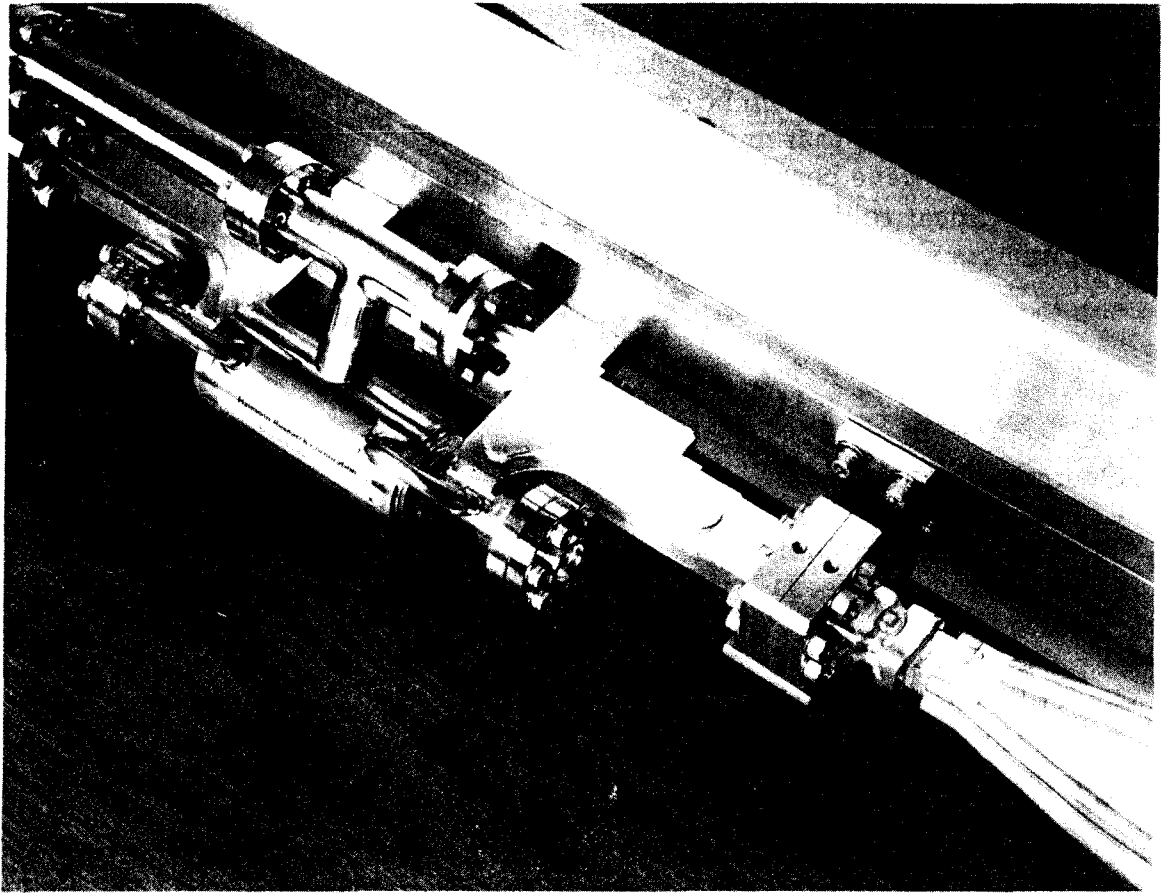

CBB 872-1468

Figure 5. Machined and Brazed 10 cm-Long BGA in Vacuum Jacket

FEL-Based Accelerator Power Sources

Before the FEL/TBA is fully realized in an actual accelerator, e.g. linear collider, microwave FELs may find an initial application as accelerator power sources. An induction accelerator coupled with a wiggler can readily produce GWs of power. These sources can then be replicated and arranged to periodically drive an HGA in the same manner that multiple klystrons drive long accelerators, e.g. at SLAC. Such sources have been proposed and preliminary cost estimates made, most recently for TeV linear collider applications at 17 GHz¹⁹. For this study, the assumed collider parameters were as shown in Table 3.

TABLE 3

Linear Collider Parameters

Operating frequency	17 GHz
Collider length	7.41 km
Total rf power required	3.87 TW
Length between rf feeds	1.44 m
rf power/m required	634 MW/m
rf pulse width	50 ns
Repetition rate	180 Hz
Luminosity (single bunch)	$5.0 \times 10^{32} \text{ cm}^{-2} \text{ sec}^{-1}$
Luminosity (21 bunches)	$1.0 \times 10^{34} \text{ cm}^{-2} \text{ sec}^{-1}$

To power this 17 GHz collider, an induction accelerator-driven FEL power source was considered which has the parameters shown in Table 4.

TABLE 4

Power Source Parameters

Beam energy	3.5 MeV
Beam current	3.0 kA
Beam energy stability ($\Delta E/E$)	0.8%
Interaction waveguide size	$6.0 \times 3.0 \text{ cm}$
Wiggler length	1.7 m
Wiggler period	12 cm
Resonant wiggler field, on axis	4.11 kG
Final wiggler field, after tapering	1.8 kG
Input rf power	80 kW
Output rf power	5.0 GW

For this application, a new, simple, inexpensive permanent magnet and steel wiggler was designed²⁰. This is shown in Figure 7. Also, an "afterburner" was assumed to follow the wiggler to extract a good fraction of the rf energy from the

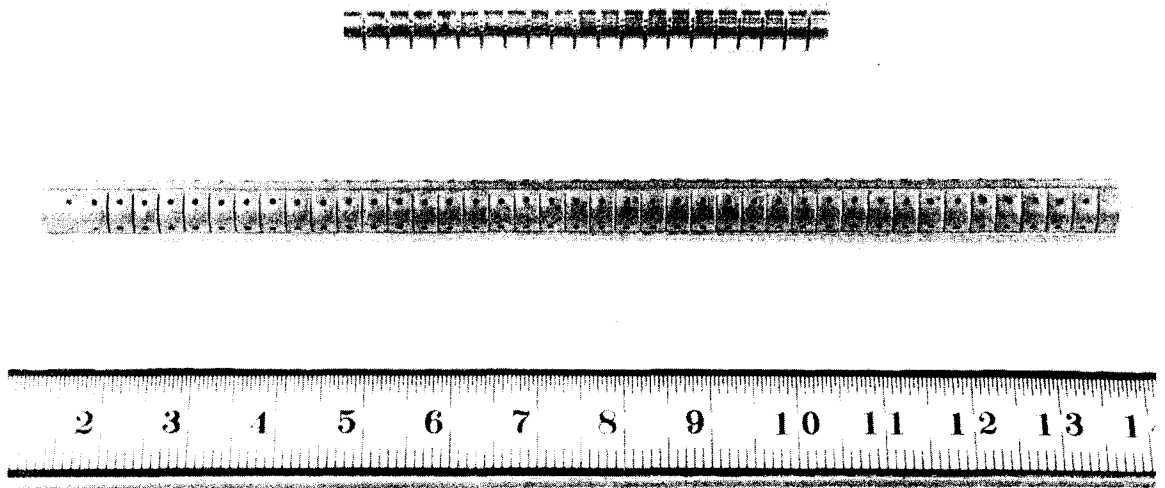

CBB 866-4777

Figure 6. Prototype Electroformed HGA with Mandrel Section

bunched beam before it is dumped. This is a final relativistic klystron stage where the beam threads a few output coupling cavities producing ~ 2 GW of additional rf power, thereby increasing overall efficiency.

For the induction accelerator driver, cost estimates were prepared on three different bases: (1) present technology, (2) a newer small-cell design under development and (3) a projected industrialized version. Estimated costs for the induction driver were, (1) \$1.8M, (2) \$1.5M, and (3) \$0.9M, respectively. The wiggler cost is found to be very small, namely \sim \$80K for a 2.1 m length. Since costs are dominated by that of the induction accelerator, efforts are being made to find ways of significantly reducing this cost.

The TBA concept has always incorporated the idea of periodic reacceleration of the drive beam. This would take place to restore the energy to the beam which had been given up to the microwave field in the FEL sections. Induction accelerator cells would be added to accomplish this.

Reacceleration can also be of benefit to the power sources being discussed in this section. For the linear collider parameters of Tables 3 and 4 and assuming the small-cell technology mentioned above, the cost and efficiency of power sources has been estimated.¹⁹ These estimates are summarized in Table 5 for four cases having no reacceleration, then one, two, and three reaccelerations. As can be seen, the difference between no reacceleration and three reaccelerations is an impressive cost saving of \$284 M and an efficiency increase to 32% from 25%.

Improved Version of an FEL/TBA

Recently, a new version of an FEL/TBA has been proposed which avoids a number of difficulties inherent in the original concept.²¹ In this version, a relatively small, stable rf clock signal is provided at the input of each FEL section. At the end of each FEL section essentially all of the rf power is removed and transported to the HGA power input ports. The bunched electrons of the drive beam go on to the next FEL section through the following reacceleration gaps. There is no longer a need for any remaining microwave power to cross these gaps.

The advantages that accrue with this configuration are many. In the original FEL/TBA concept, errors in various parameters were cumulative and resulted in the phase and amplitude sensitivities discussed earlier. The new version appears to be remarkably insensitive to errors in operating parameters. In one non-optimized design studied, a beam current variation of $\pm 3\%$ caused a phase change of only $\sim \pm 0.9^\circ$. Similarly, the operation is also tolerant of relatively large errors in beam energy, reacceleration energy and initial phase. This study considered a 14 MeV, 2.2 kA beam passing through a 1.3 m-long, 3.85 kG wiggler and producing 1.0 GW of power at a frequency of 17.1 GHz. The application was a 500 GeV x 500 GeV collider with a multi-bunch luminosity of 10^{34} cm⁻² sec⁻¹ and operating at a gradient of 180 MV/m.

Table 5. Re-Acceleration Various Number of Times

(Assume Small Cell Costs, an RK after burner, and a 3.87 TW total power requirement)

<u>Basic Unit</u>		
Injector (0-1.5 M)	\$ 920 k	
Accelerator (1.5-3.5 MeV)	\$ 620 k	
W,R,MD and M*	\$ 250 k	
Base Unit Cost	\$ 1790 k	
Power Output per Unit (5+2)		7.0 GW
Total Cost (553 units)		\$ 990 M
Beam to rf Efficiency		67 %
Overall Efficiency		25 %
 <u>Single Re-Acceleration</u>		
Base Unit Cost	\$1790 k	
Accelerator (+2 MeV)	\$ 620 k	
W,M**	\$ 120 k	
Unit Cost	\$2530 k	
Power Output per Unit (10 +2)		12 GW
Total Cost (323 units)		\$ 817 M
Beam to rf Efficiency		73 %
Overall Efficiency		29 %
 <u>Two Re-Accelerations</u>		
Base Unit Cost	\$ 1790 k	
Accelerators (+4 MeV)	\$ 1240 k	
W,M**	\$ 240 k	
Unit Cost	\$ 3270 k	
Power Output per Unit (15+2)		17 GW
Total Cost (228 units)		\$ 746 M
Beam to rf Efficiency		76 %
Overall Efficiency		31 %
 <u>Three Re-Accelerations</u>		
Base Unit Cost	\$ 1790 k	
Accelerators (+6 MeV)	\$ 1860 k	
W,M**	\$ 360 k	
Unit Cost	\$ 4010 k	
Power Output per Unit (20+2)		22 GW
Total Cost (176 units)		\$ 706 M
Beam to rf Efficiency		77 %
Overall Efficiency		32 %

* Wiggler, Relativistic Klystron, Microwave Driver, and Microwave Equipment

** Wiggler and Microwave Equipment

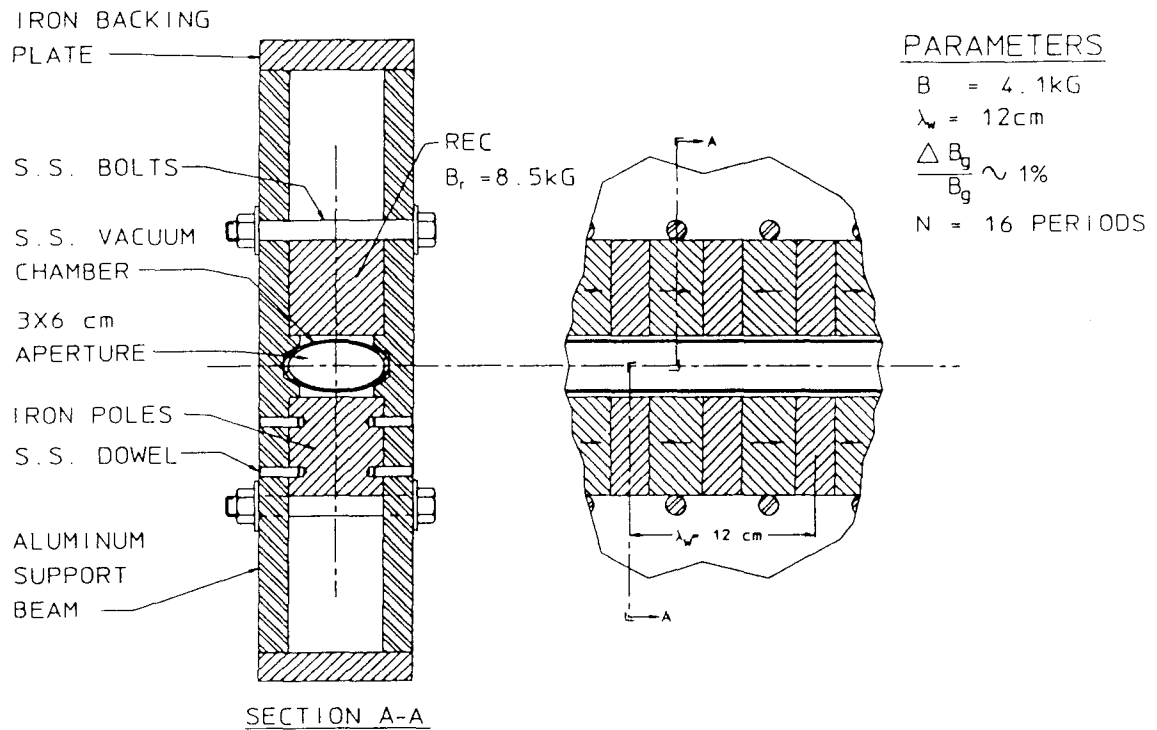

XBL 8811-3861

Figure 7. Permanent Magnet Wiggler for 17 GHz FEL

The above study employed 1-D FEL equations of motion in a rectangular waveguide. The particle simulation analysis used the CRAY-XMP supercomputer. Analysis and simulations are continuing as we explore different parameter regimes and try to gain a fuller understanding of the reasons for the insensitive nature of this new version of an FEL/TBA. The analysis will soon be extended to two dimensions. In the meantime, we have begun a search for a practical method for extracting all of the rf power at the end of an FEL section. One method which appears workable is to employ a specially-designed magnet at the end of the FEL. This would introduce a short, brief, achromatic jog of the electron beam away from the centerline, separating it from the microwave field²². In the beam-free region thus created, centered on the machine axis, an angled "mirror" would then reflect the microwave power out of the machine.

Conclusion

Research into induction linac-powered FELs is actively proceeding. Induction driver costs dominate power source costs, indicating that this technology is ripe for cost reduction studies. The cost of wigglers is nearly negligible, by comparison. A promising new FEL/TBA version is under study which should lend itself well to a practical realization and stable operation.

Acknowledgements

This paper reports on work conducted by a large number of people over the last several years. Others offered expert advice on various issues. At LLNL, they are W. A. Barletta, R. J. Briggs, F. W. Chambers, J. C. Clark, J. W. Dini, J. C. Farmer, W. M. Fawley, R. A. Jong, R. W. Kuenning, V. K. Neil, T. J. Orzechowski, A. C. Paul, D. Prosnitz, L. L. Reginato, E. J. Scharlemann, R. D. Stever, A. L. Throop, G. A. Westenskow, S. M. Yarema and S. S. Yu. At LBL, they are C. L. Chavis, K. Halbach, E. H. Hoyer, G. W. Koehler, H. O. Krapf, F. B. Selph, E. J. Sternbach, G. D. Stover, and D. H. Whittum. At other laboratories, they are G. A. Loew, P. L. Morton and P. B. Wilson of SLAC, J. S. Wurtele of MIT., R. B. Palmer and C. Pellegrini of BNL, B. R. Anderson of the U.S. Air Force Weapons Laboratory at Albuquerque, N. M., and H. A. Johnsen of Sandia Laboratory, at Livermore Ca. Finally, in private businesses, are J. Haimson and B. Mecklenburg of Haimson Research Corporation and J. R. Bayless of Pulse Sciences, Inc.

References

1. A. M. Sessler, "The Free Electron Laser as a Power Source for a High-Gradient Accelerating Structure", in Laser Acceleration of Particles, P. J. Channel ed. (AIP Conf. Proc. No 91, American Institute of Physics, New York, 1982), p. 154-159
2. D. B. Hopkins and A. M. Sessler, "The Two Beam Accelerator", Proc. 1986 Linear Accelerator Conf., June 2-6, 1986, SLAC, 385 (1986)

3. T. J. Orzechowski, et al., in Free Electron Generators of Coherent Radiation, C. A. Brau, S. F. Jacobs, M. O. Scully, editors (SPIE, Bellingham, WA, 1983) p. 65
4. E. J. Scharlemann, *J. Appl. Phys.* 58 (1985), 2154
5. T. J. Orzechowski, et al., "High Gain and High Extraction Efficiency from a Free Electron Laser Amplifier Operating in the Millimeter Wave Regime", *Nucl. Inst. & Meth. in Phys. Res.* A250, 144 (1986)
6. A. L. Throop et al., "Experimental Characteristics of a High-Gain Free-Electron Laser Amplifier Operating at 8-mm and 2-mm Wavelength", *Proc. AIAA 19th Fluid Dynamics, Plasma Dynamics and Laser Conf., Honolulu, Hawaii, June 8-10 (1987)*
7. T. J. Orzechowski, et al., "Measurement of the Phase of the Electromagnetic Wave in a Free-Electron Laser Amplifier", *Phys. Rev.* A355, 2184, March 1 (1987)
8. A. L. Throop, et al., "Experimental Results of a High Gain Microwave FEL Operating at 140 GHz", *Nucl. Inst. & Meth. in Phys. Res.*, A272, 15 (1988)
9. R. A. Jong, et al., "Baseline Design for the IMP Wiggler", *Subm. to Journ.. Appl. Phys.*, April (1988) also UCRL-98214
10. R. A. Jong, et al., "Wiggler Taper Optimization for Free-Electron Laser Amplifiers with Moderate Space-Charge Effects", *Nucl. Inst. & Meth. in Phys. Res.*, A272, 15 (1988), also UCRL-96735
11. F. B. Selph and A. M. Sessler, "Transverse Wakefield Effects in the Two Beam Accelerator", *Nucl. Inst. & Meth. in Phys. Res.*, A244, 323, (1986)
12. V. E. Balakin et al., *Proc. of 12th International Conference on High Energy Accelerators (Fermi National Accelerator Laboratory, 1983)* pp. 119-120.
13. K.L.F. Bane, "Landau Damping in the SLAC Linac", *IEEE Trans. on Nuc. Sci.* NS-32, 5, 2389 (1985)
14. J. Masud, et al. "Sideband Control in a Millimeter Wave Free Electron Laser", *Phys. Rev. Ltr.* 58, 763 (1987)
15. D. B. Hopkins, et al., "Fabrication and 35 GHz Testing of Key Two-Beam Accelerator Components", *Proc. 1987 IEEE Part.. Accel. Conf., IEEE Cat. No. 87CH2387-9*, 1, 80, Mar. 16-19 (1987)
16. R. W. Kuenning, et al., "Radio Frequency Phase in the FEL Section of a TBA", *Proc. of the 8th International Free Electron Laser Conference, Nucl. Inst. & Meth. in Phys. Res.* A259, 219 (1987)

17. Y. Goren and A. M. Sessler, "Phase Control of the Microwave Radiation in Free Electron Laser Two Beam Accelerator", Proc. of the Workshop on New Developments in Particle Acceleration Techniques, Orsay, France, July (1987)
18. D. B. Hopkins, et al., "Design and Fabrication of 33 GHz High-Gradient Accelerator Sections", Proc. of European Part. Accel. Conf., Rome, Italy, June 7-11 (1988), also LBL-25368
19. D. B. Hopkins, et al., "An FEL Power Source for a TeV Linear Collider", Proc. 1988 Lin. Accel. Conf., Williamsburg, Va., October 2-7 (1988), also LBL-25936
20. Wiggler designed by K. Halbach and E. H. Hoyer
21. A. M. Sessler, et al., "A New Version of a Free Electron Laser Two Beam Accelerator", Proc. Tenth Int. Conf. on Applications of Accelerators in Research and Industry, Denton, Texas, November 7-9 (1988), also LBL-25937
22. Suggested by A. C. Paul