

10-23-90 J.S. ①

CONF-9009123-49

SLAC-PUB-5337
October 1990
(A)

SLAC-PUB--5337

NEW COMPENSATION OF TRANSVERSE WAKEFIELD EFFECTS IN A LINAC BY DISPLACING ACCELERATING STRUCTURES*

DE91 002976

John T. Seeman
Stanford Linear Accelerator Center, Stanford, California 94305

Abstract

Beams accelerated in the linac of a linear collider experience transverse wakefield effects due to small residual misalignments of the accelerating structure. These wakefields lead to emittance growth. The traditional correction method is to add induced betatron oscillations to the trajectory of the beam to counteract the effects of the unknown actual errors and, thereby, reduce the emittance enlargement. However, practical considerations make this solution operationally difficult. In this note a second correction method is proposed where the positions of the accelerating structures are remotely controlled. By adding position offsets of the RF structure at the spatial frequency of betatron oscillations, direct wakefield reduction can be made. A hardware solution suitable for the SLC is presented which does not move the quadrupoles or position monitors.

History

The correction method for misaligned structures which is traditionally proposed [1,2] has three parts. (A) The beam is steered to the axis of the linac at low beam currents. (B) The beam intensity is then raised, exposing the effects of the misaligned structures in terms of trajectory errors and emittance growth. (C) The injection launch conditions into the linac (x,x',y,y') of the centroid of each beam are adjusted to minimize the emittance at the exit of the linac. Trajectory amplitudes comparable to the beam size are usually required. Experimentally, this correction has been shown to work [3]. However, the following practical considerations make this solution difficult to use. The optimization requires eight parameters to be adjusted simultaneously. This pushes the limit for human control, requiring computer feedback and complicated data analysis (spot shape determination). Furthermore, the reference trajectories for the launch feedback controllers need non-zero values which change with time. Finally, the requirement that both beams be steered at low currents then raised to high currents leads to beam loss problems (the trajectories change drastically), makes positron production problems (e.g. scavenger extraction energy changes and Sector 1 beam loading), and exasperates current dependant effects of the damping rings and bunch length compressors.

Effects of randomly misaligned accelerating structures

A two particle model of transverse wakefields will be used to calculate the effects of random displacements of accelerating structures. The only misalignments in the accelerator complex are the disk-loaded waveguide sections through which the beams pass. The head particle of charge N/2 traverses the entire linac in a straight line. The tail particle (charge N/2) follows the same trajectory as the head until a misaligned accelerator is reached as is shown in Fig. 1. The transverse wakefields produced by the head in this off-axis accelerator will deflect the tail which will subsequently execute a betatron oscillation. The betatron oscillation from all the misalignments will add linearly.

* Work supported by Department of Energy contract DE-AC03-76SF00515.

For these calculations we assume smooth focusing with constant betatron wavelength λ_β , no acceleration (can be added if needed), and lengths of offset accelerators that are short compared to λ_β . The transverse offset x_2 of the tail particle at the end of the linac is given by the standard transport equation downstream of the position (z_i) of the i th misaligned accelerator.

$$x_2(L) = \theta_i \beta_0 \sin [k(L - z_i)] \quad (1)$$

where the deflection angle θ_i is given by

$$\theta_i = C d_i l_0 / E_0 \quad (2)$$

and

$$C = (e^2 N W) / 2. \quad (3)$$

W is the value of the wakefield potential on the tail particle, d_i the transverse offset of the accelerator structure, l_0 the length of a typical RF structure, e the electron charge, E_0 the beam energy, β_0 the average betatron function, and k the lattice spatial frequency. $L = n l_0$ where n is the number of structures. Each structure is assumed to have a uniform offset. Angles can easily be added but do not add anything new to the calculation.

An rms tail offset for an ensemble of machines can be calculated by summing the offsets over the entire linac assuming that the accelerator offsets are random with a normal distribution. Replacing the summation by an integral, the rms offset can be obtained.

$$\langle x_2(L) \rangle_{rms} = C \beta_0 \langle d_{rms} \rangle l_0 \sqrt{n/2} / E_0 \quad (4)$$

For example, with $N=5 \times 10^{10}$, $\langle d_{rms} \rangle = 400$ microns, $\beta_0 = 20$ m, $l_0 = 12$ m, $E_0 = 10$ GeV, $C=0.011$ GeV/m² (particle separation = 2 mm), and $n=232$, then $\langle x_2(L) \rangle_{rms} = 1.1$ mm. This value significantly enlarges the emittance (X 20) and devastates the luminosity. However, if the beam is launched with a selected offset and angle, then wakefield effects due to the forced betatron oscillation can be made to reduce the accumulated effects from random misalignment on the tail [1] calculated from Eqn. (1).

Complications from BNS damping

A method to reduce the effects of injection launch jitter on emittance growth is to introduce an energy difference between the head and tail of the bunch [2,4]. This method works most effectively if the following condition is satisfied (from the two particle model).

$$e^2 N W / (4 E_0 k \delta k) = 1 \quad (6)$$

Here $k = 2\pi / \lambda_\beta$. The difference in k between the head and tail is δk , with the tail having the lower energy and higher k . The difference in k is chosen to make the wakefield force and the additional quadrupole lattice focusing cancel. When Eqn. (6) is

Contributed to the Linear Accelerator Conference, Albuquerque, New Mexico, September 10-14, 1990.

MASTER

DISTRIBUTION OF THIS DOCUMENT IS UNLIMITED. *EP*

satisfied, the tail follows the head exactly along the linac during a betatron oscillation and no growth occurs. Therefore, once BNS damping is used, the above correction scheme of induced injection launch oscillations to cancel misalignment errors is no longer effective. Another method must be used. (The BNS damping actually used in the SLC does not satisfy Eqn. (6) exactly and, thus, injection errors can be used to cancel structure offset effects. However, the magnitude of the required injection errors must be larger than without BNS damping.)

The effects of coherent structure misalignments

A control of the tail displacement can be obtained by deliberately displacing the RF structure at the betatron spatial frequency through external means. With mechanical displacements set at the betatron frequency of the bunch tail, all the deflections received by the tail add coherently and a large effect is obtained. Since the lattice is unchanged, the trajectory of the head particle remains a straight line. These driven offsets will be used to cancel random errors in the structure alignment. BNS damping will not affect the coherent addition of the displacement effects if the spatial frequency of the displacements is that of the tail of the bunch (not the head) including both the lattice and wakefields effects.

Given a structure offset along the linac with amplitude d_a and spatial frequency of the tail k_{tail} , the tail offset at the end of the linac (L) can be calculated using the two particle model (Eqn. 1).

$$x_2(L)_{driven} = \frac{C d_a n l_0}{2 E_0 k} \cos(k_{tail} L) \quad (7)$$

The ratio of this driven tail growth (cosine = 1) to that produced by random offsets can be obtained from Eqns. (4) and (7).

$$\frac{x_2(L)_{driven}}{\langle x_2(L) \rangle_{rms}} = \frac{\sqrt{n/2} d_a}{\langle d_{rms} \rangle} \quad (8)$$

where $k \beta_0 = 1$. For $n = 232$ and $\langle d_{rms} \rangle$ about 400 microns, a coherent distortion d_a of about 37 microns on the average along the linac can be used to 'cancel' the average random build up. This is not a large mechanical movement. Algorithms using the position information along the linac as well as beam size information at the exit of the linac can be made to optimize this effect allowing local as well as global adjusts to be made.

With this new control the procedure for increasing the beam current would be to (1) steer the beam at low intensity, (2) raise the intensity, and (3) adjust the structure offsets until the low intensity trajectory and emittance are restored. It is believed that if the betatron spatial wavelength along the linac is maintained while the accelerator conditions drift, this correction will be stable with time.

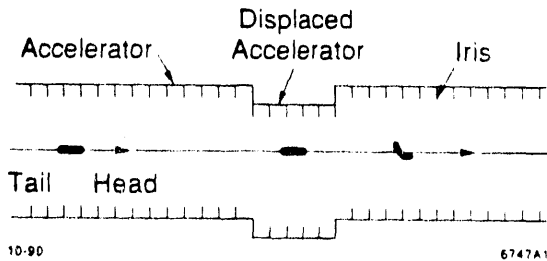

Fig. 1 Displaced accelerator structures produce wakefields effects.

Computer simulation

A computer tracking program WAKTRKACCEL was used to study the effects of random and driven structure offsets. A simulated beam with 24 longitudinal slices using acceleration and a corrected (0.3%) energy spectrum at 47 GeV was studied. The as-used SLC lattice and energy profile were used with a beam of 5×10^{10} particles. The bunch length was 1.0 mm. Accelerator offsets for each 12 m girder had an rms value of 4(0) microns and were distributed as a gaussian to (+/-) three sigma.

The transverse displacements of the slices from the accelerator axis were used to compute the emittance for an ensemble of twenty distinct machines with offsets. Ten accelerators used no BNS damping with all klystron phases at +9 degrees to compensate longitudinal loading. The other ten simulated accelerators used BNS damping with the first 56 klystrons at -25 degrees and the remaining 176 klystrons at +18 degrees. Then, accelerator offsets at the betatron frequency were added to compensate the errors in each case. The phase and amplitude of the offsets were adjusted for minimum emittance. The emittance enlargements without BNS damping were reduced by a factor of 100 to 400 using coherent displacements with amplitudes of 50 to 400 microns. With BNS damping the initial emittance enlargements with random offsets but no compensation were about 50 to 100 times smaller than with no BNS. However, the use of coherent offsets at the betatron frequency with BNS damping did reduce the emittance enlargements by a factor of 1.5 to 8 with structure offset amplitudes of 70 to 400 microns. The resulting compensated emittances in both cases were approximately the same. These results confirm the expectation that the required coherent driven oscillations would be larger with BNS damping than without it for a given enlargement, but BNS damping allows less enlargement initially. The amplitudes of the moved structure were larger than predicted from the two particle model which indicates that a more complete calculation would have nonlinear terms and that acceleration plays a role.

Additional studies are underway to determine why the emittance reduction for all the random seeds are not equal and to determine the effects of a discrete focusing lattice (FODO).

Application to the SLC Linac

The SLAC Linac was fortuitously constructed in a way which allows independent adjustment of the transverse position of the disk loaded waveguide (DLWG) relative to the quadrupoles and beam position monitors [5,6]. The position monitors are mounted inside the quadrupoles which are in turn mounted on the thick aluminum girder end plates. Each girder end plate is supported directly from the tunnel floor and wall by rigid but adjustable jacks. A general layout is shown in Fig. 2. The accelerator structure is supported by a 40 foot, 24 inch diameter aluminum light pipe suspended between the girder end plates. The proposal here is to add remotely controlled horizontal and vertical jacks anchored to the floor and wall and attached to the center of the girder to force movements of up to +/- 1 mm. The center of the girder will move, but the girder ends including the quadrupoles and position monitors do not move as they are firmly held by the end jacks. The structure when bowed with an amplitude of up to 1 mm will give a net offset of about 0.5 mm to the entire girder, which is sufficient for wakefield correction given the spectrum of offset errors known for our accelerator. The accelerator with distortions adjusted to the betatron frequency would look like the schematic in Fig. 3.

The accelerator will not be damaged by these adjustments. Each girder supports four 10-foot sections. Each section has its own independent strongback which is supported at each end. The sections are welded together by a flexible islet. The flexing of the girder during the proposed control will occur at these islets. The worst angle is in the center islet where only 0.002 inch

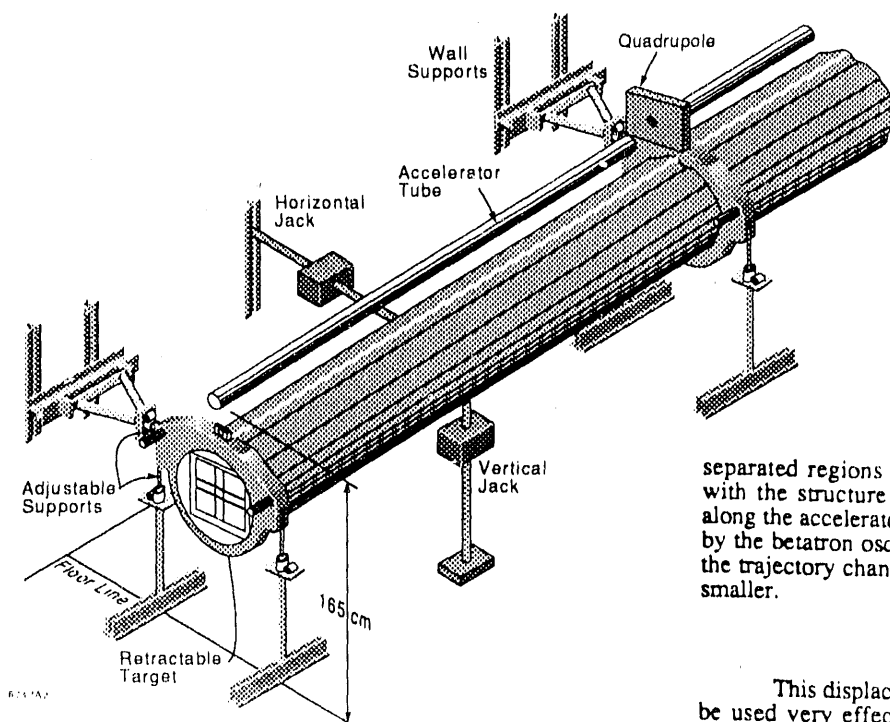

Fig. 2 Schematic view of position jacks to produce offsets in the center of the girders. The position of the end supports holding the quadrupoles remains fixed.

separated regions of the accelerator containing errors. Fourth, with the structure displacement the head of the bunch travels along the accelerator on axis rather than oscillating off axis given by the betatron oscillation correction. Since the head is on axis, the trajectory changes with beam current changes will likely be smaller.

Future linear collider

This displacement technique of accelerating structures can be used very effectively in the next linear collider where the alignment tolerances are very tight. Since the misalignments at the betatron frequency are the main concern, this technique addresses this problem directly. Alignment errors over a very local region in the structure are not as important and can have much looser tolerances. An improvement of the structure tolerance of an order of magnitude is expected. New simulations will address this issue.

differential motion is expected over the islet diameter of 6 inches. This motion is not likely to be a problem. The present alignment procedure of the linac quarter points produces more flexing than this new control would make. However, the new procedure would be done more frequently.

There are several possible designs for the new jacks. The present plan calls for connecting arms on 'belly bands' attached to worm gear linear jacks driven by CAMAC. Since speed is not required, the CAMAC modules could drive the motors directly. Only one CAMAC module would be needed for several linac sectors if a simple fan-out chassis is built. The cost must be low as there are about 240 motor units to build and installed if half the linac is instrumented. Since the girders have known spring constants (500 lbs in the center bends a girder 1 mm horizontally and 0.7 mm vertically), load cells could be used to measure the applied force. Linear potentiometers could also be used to measure the position. The arms should be built such that any longitudinal motion of the girder is not resisted, such as for temperature cycling. Some adjustments in the connecting arms are needed when the girder end jacks are moved during normal quadrupole alignment. Finally, the movers must be earthquake resistant.

Some software support is needed to provide for online adjustment of these mechanical offsets and to calculate the sine and cosine spatial frequencies for both horizontal and vertical planes. Positrons and electrons experience the same corrections with slight differences given by their complementary betatron functions.

Structure displacements versus oscillating beams

If betatron oscillations starting at the entrance to the linac can be used to reduce the emittance growth, why should the effort and expense be used to make the accelerating structure movable? First, the structure alignment tolerance can be made less tight. Second, the structure movers can be used to cancel many error frequencies within the accelerator. Third, if the offset errors can be cancelled reasonably locally, then the displacement correction is likely to be stable over a long time. Both correction techniques suffer from changes in the energy profile along the accelerator which changes the betatron phase advance between

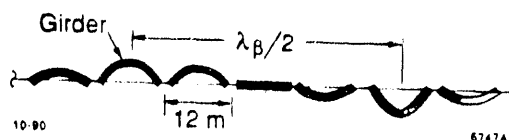

Fig. 3 Use of distorted accelerator girders to make structure offsets at the betatron spatial frequency.

References

- [1] A. Chao, B. Richter, and C. Yau, "Beam Emittance Growth Caused by Transverse Deflecting Fields in a Linear Accelerator", NIM 178 (1980) pages 1-8.
- [2] K. Bane, "Wakefield Effects in a Linear Collider", SLAC-PUB-4169.
- [3] J. Seeman *et al.*, "Observation and Control of Emittance Growth in the SLC Linac", XIV Int. Conf. on High Energy Accelerators, Tsukuba, Japan, 1989, Also SLAC-PUP-4889.
- [4] V. Balakin, A. Novokhatsky, and V. Smirnov, "VLEPP: Transverse Beam Dynamics", 12th Int. Conference on High Energy Accelerators, FNAL, p. 119, 1983.
- [5] R. Neal *et al.*, *The Stanford Two-Mile Accelerator*, W. Benjamin, Inc., 1968.
- [6] J. Seeman and J. Sheppard, 'Special Linac Developments', 1986 Linac Conference SLAC, p. 214.

END

DATE FILMED

12 / 12 / 90

