

30
1/27/89 JS (1)

CONF-8806258.

SLAC-PUB-4820

December 1988

(A)

RADIO FREQUENCY PULSE COMPRESSION*

Z. D. FARKAS

Stanford Linear Accelerator Center, Stanford, California 94309

INTRODUCTION

High gradients require high peak powers. One possible way to generate high peak powers is to generate a relatively long pulse at a relatively low power and compress it into a shorter pulse with higher peak power. It is possible to compress before DC to RF conversion as is done for the relativistic klystron or after DC to RF conversion as is done with SLED. In this note only radio frequency pulse compression (RFPC) is considered. Three methods of RFPC will be discussed: SLED,^[1] BEC,^[2] and REC.^[3]

The advantages of RFPC are:

1. Generally the higher the power, the harder it is to increase it further. This is not the case with SLED and BEC because the control element operates at low power.
2. With RFPC we can alternate low power uncompressed pulses and high power compressed pulses by turning the modulation off and on. It is much more difficult to design tubes that function both at low and high peak powers.
3. RFPC may have lower capital, maintenance and replacement costs.
4. For a given compression ratio, the cost of RFPC is independent of pulse energy or peak power.

* Work supported by the Department of Energy contract, DE-AC03-76SF00515.

*Invited paper presented to the Workshop on Physics of Linear Colliders,
Capri, Italy, June 13-17, 1988*

The effect of pulse compression on the klystron peak power per meter p_{pk} and klystron average power per meter p_{ak} can be seen from the following expressions. The peak and average powers required to produce an average gradient E_a in an accelerator section are:

$$p_p = \frac{E_a^2}{\eta_a s T_f} \equiv \frac{E_a^2}{r_i} \quad s \equiv \frac{E_a^2}{w}$$

$$p_a = f_r p_p T_f = f_r \frac{E_a^2}{\eta_a s} \equiv f_r \frac{E_a^2}{s_i}$$

$$r_i = \eta_a s T_f = s_i T_f \quad s_i = \eta_a s$$

A pulse compression system with a multiplication factor, M , a compression factor, C_f , and compression efficiency, η_{pc} , defined below,

$$M = \frac{p_p}{p_{pk}} \quad C_f = \frac{T_h}{T_f} \quad \eta_{pc} = M/C_f$$

decrease the klystron peak power by M and increase the klystron average power by the inverse of η_{pc} , as indicated below

$$p_{pk} = \frac{p_p}{M} = \frac{E_a^2}{M r_i} \quad p_{ak} = \frac{p_a}{\eta_{pc}} = \frac{E_a^2}{\eta_{pc} s_i}$$

Two important parameters, the ac to RF conversion efficiency η_{ar} and the AC elastance s_{ac} are defined below:

$$\eta_{ar} \equiv \frac{p_{ak}}{p_{ac}} = \frac{f t}{f t + r t} \cdot \eta_{kr} \quad s_{ac} = \eta_{ar} \eta_{pc} s_i \quad \frac{p_{ac}}{f_r} = \frac{E_a^2}{s_{ac}}$$

The AC elastance determines the AC power needed at a given repetition rate and at a given gradient. It should include the power required for focusing coils and, in case of superconducting accelerators, the refrigerator power.

Note that the increased average RF power due to RFPC does not necessarily imply increased AC line power. For example, replacing SLED by a 160 MW 1 μ s klystrons, would, in fact, increase the AC power. The reason is that the rise and fall times of the modulator pulse become a larger fraction of the flat-top RF pulse, which decreases the AC to RF conversion efficiency, η_{ar} .

SLED

The klystron peak and average powers without and with SLED as a function of fill time are shown in Fig. 1. Note that for the same RF power the fill time can be decreased and hence the aperture can be increased 60%, resulting in lowered wake fields.

The disadvantages of SLED are:

1. Reflected power during charging.
2. Compressed pulse is a constant and an exponential.
3. The compression efficiency falls off sharply as the compression factor deviates from about 3:1.
4. The multiplication factor cannot be greater than 9.

The compression efficiency is also reduced because of dissipation losses due to finite Q_0 of the energy storage cavity. For the dissipation to be a small fraction of the klystron RF power requires that the internal (unloaded) fill time of the energy storage cavity be much greater than the uncompressed pulse length.

BINARY ENERGY COMPRESSOR

The Binary Energy Compressor (BEC) overcomes the shortcomings of SLED. It also overcomes the dissipation loss by using as energy storing elements TE_{01} circular guides whose losses decrease as the 3/2 power of frequency for a fixed diameter and as the cube of the diameter for a fixed frequency. The BEC consists of a series of stages, each stage consists of a 4-port 3 dB hybrid with one port

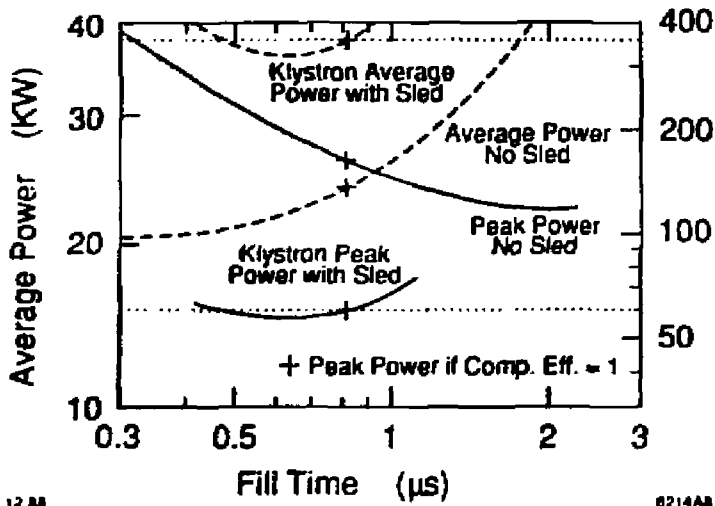

Fig. 1. SLC klystron peak and average powers without and with SLED.

followed by a delay line. The last delay equals the duration of the compressed pulse. Each additional delay toward the BEC input is double the previous delay. The two input pulses to the BEC are divided into 2^n equal bins. The length of each bin is the length of the compressed pulse. Each bin is coded with the phase shift keyer (PSK) with either a zero or 180° phase shift. Consequently the output pulse length is divided by 2^n and, ideally, the power is multiplied by 2^n , where n is the number of stages.

For a 2-stage BEC, shown in Fig. 2, we divide a portion of the two CW inputs, I_{a1}, I_{b1} into four bins. We code them as shown: the + indicates zero phase shift, the - 180 phase shift. The duration of each bin equals the time delay of the last delay line. During bins one and two the combined power exits port O_{a1} and is delayed two bins, so that it coincides in time with bins three and four, which are combined at port I_{b2} . The phase of either output is that of input a . We see that the appropriate coding of the input to the first stage results in appropriate coding of the input to the second stage. This illustrates the divide and combine (slice and stack) method. For a CW input, the first stage combines the two inputs and the second stage divides it. Thus, an even stage BEC is transparent to a CW input.

Therefore, it can be used for pulse to pulse switching between a high power short pulse and a lower power longer pulse.

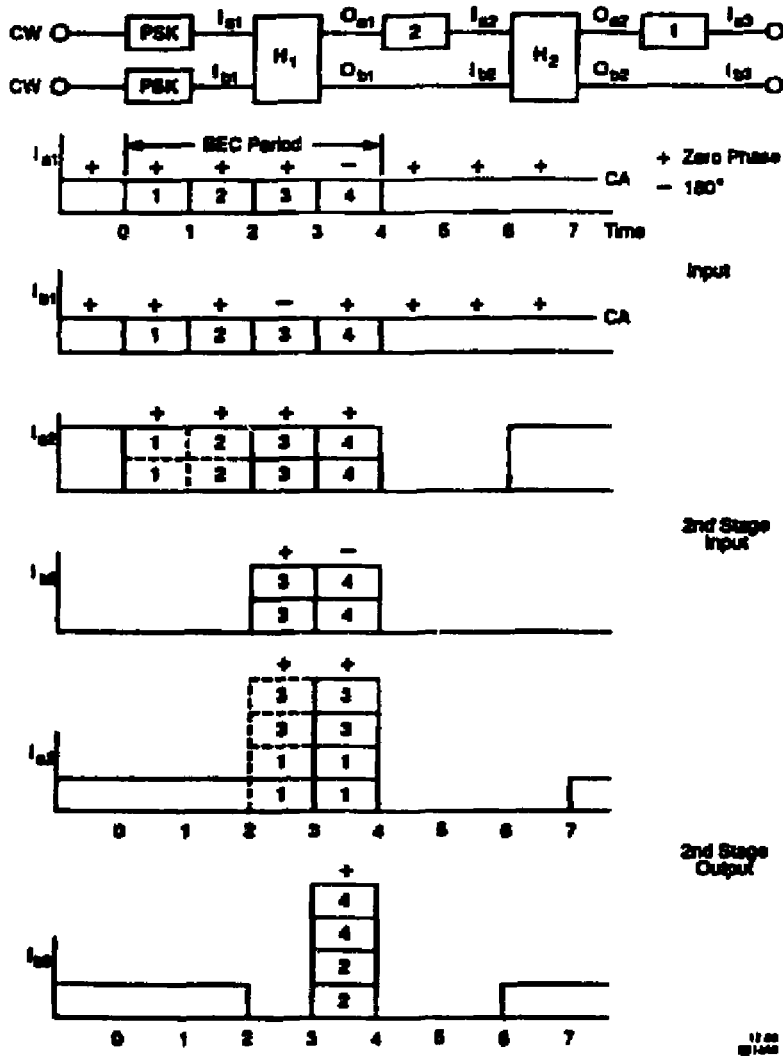

Fig. 2. 2-Stage BEC Coding.

Tests performed on an experimental BEC, shown schematically in Fig. 3, confirmed the theoretically predicted operation of a 1-stage (x2), a 2-stage (x4) and a 3-stage (x8) BEC. Outputs of the experimental BEC are shown in Fig. 4. The

first OSC shows the 2-stage BEC output with CW input modulated for one BEC period. The second shows the expanded output pulse which has a 65 ns flat top and about 10 ns rise time. The third OSC shows the two BEC period modulation signal for a 2-stage BEC; the fourth the consequent output. The fifth shows continuous modulation. The sixth shows the resultant periodic output pulses and also the CW output when there is no input modulation. The BEC period T_p is 300 ns. It should have been $4 \times 70 = 280$ ns. The extra 20 nanoseconds is due to the finite PSK switching time.

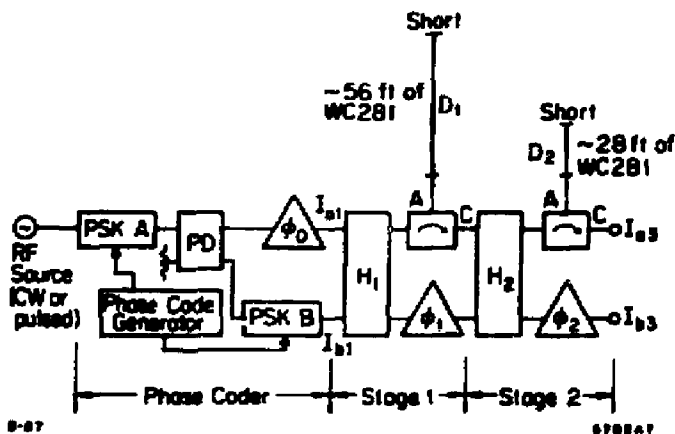

Fig. 3. Experimental BEC.

BEC PHASE AND AMPLITUDE SENSITIVITIES

If the relative phase of unity amplitude hybrid inputs I_a and I_b differ from the properly adjusted BEC phase by $\Delta\theta$ radians then the output powers are not two and zero, but

$$O_a = 1 + \cos \Delta\theta \quad \text{and} \quad O_b = 1 - \cos \Delta\theta \quad .$$

For small $\Delta\theta$:

$$O_a = 2 - (\Delta\theta)^2/2 \quad \text{and} \quad O_b = (\Delta\theta)^2/2 \quad .$$

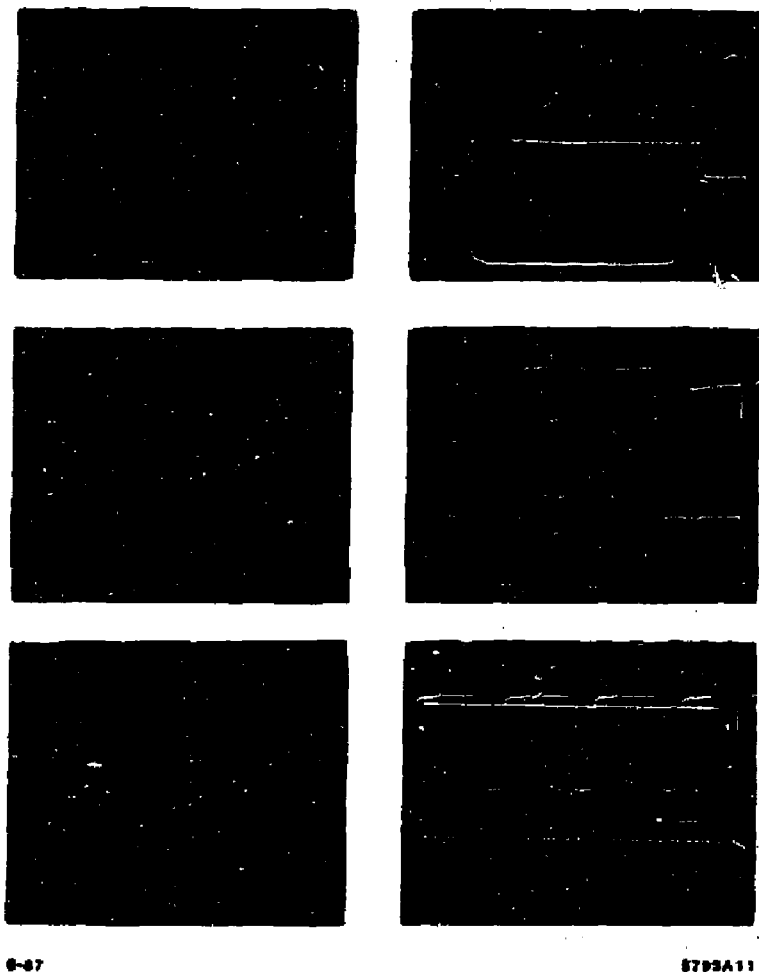

Fig. 4. Oscillograms of 2-Stage BEC outputs.

The phase deviation due to changes in frequency, $\Delta\theta_f$, and due to changes in temperature, $\Delta\theta_T$, are:

$$\Delta\theta_f = 2\pi T_d(\text{ns})\Delta f(\text{GHz})$$

$$\Delta\theta_T = 2\pi\alpha(^{\circ}\text{F}^{-1})T_d f\Delta T(^{\circ}\text{F}) = 6 \times 10^{-5} T_d f\Delta T(^{\circ}\text{F})$$

For $T_d = 140 \text{ ns}$, $f = 11.4 \text{ GHz}$, $\Delta T = 1^{\circ}\text{F}$, $\Delta\theta_T = 0.1 \text{ radian}$.

It can be shown that, if the relative amplitudes of the inputs to a hybrid differ by δ^2 , where $\delta = 1 - \sqrt{I_b/I_a}$, then

$$O_a = 2 - \delta^2/4 \quad \text{and} \quad O_b = \delta^2/4 \quad .$$

DELAY LINE ATTENUATION

The attenuation of a TE_{01} circular guide is:

$$A = \frac{932}{D^3(\text{in})f^{3/2}(\text{GHz})} \quad (\text{dB}/\mu\text{s}) \quad .$$

The attenuation of a TE_{10} circular guide is:

$$A = \frac{2.25\sqrt{f}(\text{GHz})}{b(\text{inch})} \left[1 + \frac{b}{2a} \left(\frac{\lambda}{a} \right)^2 \right] \quad (\text{dB}/\mu\text{s}) \quad .$$

The length of the longest delay line divided by the length of an accelerator section is:

$$\frac{L_{dl}}{L_a} = 2^{n-2} \frac{\beta_{gd1}}{\beta_{ga}} \quad .$$

For 2.8 inch diameter circular guide at 11.4 GHz, the TE_{01} attenuation is 1.2 dB per microsecond and 0.004 dB/m. The TE_{01} mode is more suitable for power distribution, regardless of how the RF power is generated.

Replacing the 2856 MHz klystron and accelerator sections with 11.4 GHz klystrons and sections and adding a 3-stage BEC, but keeping the same 3.3 m section lengths, the same AC line power, and the same modulators, can increase the pulse repetition rate nine-fold. The systems are compared in Table 1. The reduction in elastance due to increased a/λ is more than compensated for by the decrease in maximum radius.

Table 1. SLAC linac parameters at 2856 GHz with sled and at 11.4 GHz with 3-stage BEC.

	SLED	3-Stage BEC
Frequency (MHz)	2856	11424
a (cm)	1.16	0.75
b (cm)	4.06	1.29
a/λ	0.11	0.285
β_s	0.0134	0.192
E_{rf}	2.10	3.3
T_f (ns)	820	57
s_i (ohm/ps - m)	45	326
r_i (ohm/m)	40	18.6
RFPC Parameters:		
L_{01} (m)	—	50.0
C_f	4.27	8.7
M	2.63	6.5
η_{pc}	0.62	0.75
Drive Parameters: $E_0 = 21$ MV/m		
P_{pt} (MW) for 4 sections	60	48
T_k (μ s)	3.5	0.496
P_{ec} (kW) for 4 sections	80	80
s_{ec} (ohm/ps - m) $\eta_{br} = 0.31$	8.64	75.8
f_r (Hz)	120	1040
P_{st} (kW) for 4 sections	25	25

RF ENERGY COMPRESSOR

The RF Energy compressor (REC) uses both PSK and Q_c switching to convert CW RF into periodic pulses, ideally with 100% efficiency. The cavities continuously store energy and act as flywheels. For a large fraction of the period the cavities

accumulate additional energy, which they give up during a small fraction of the period. The time durations and external Q s are so chosen that the average emitted field is unity, causing a zero reflected field at charging time midpoint and small reflected fields during the rest of the charging time. Thus, on the average, the cavities are matched to the line. Typical REC output waveforms are shown in Fig. 5.

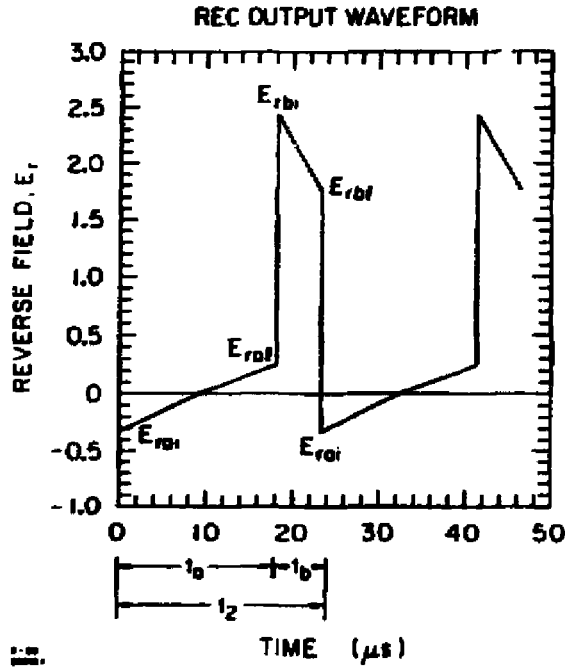

Fig. 5. Typical REC output waveforms.

For an efficient REC, the ratio of external Q during charging to the external Q during discharging is:

$$\frac{Q_{ca}}{Q_{cb}} = [\sqrt{C_f} - 1]^2$$

The pulse compression efficiency is:

$$\eta_{pc} = 1 - \frac{Q_{ca}}{Q_0} - \frac{1}{6} \left[\frac{T_d}{T_{ss}} \right]$$

The conditions for high efficiency are:

$$T_{cb} > T_b, \quad T_{ca} > T_a, \quad T_0 \gg T_{ca} .$$

Here T_a is the charging time, T_b is the discharge time, T_{ca} and T_{cb} are the external time constants during charging and discharging, respectively. The switching time has to be much less than T_f . The external time constant during discharge must be greater than discharge time, which is made equal to the fill time. The internal time constant during charging must include the energy lost through the aperture, therefore it more practical to use the same aperture for both charging and discharging, as shown in Fig. 6. The hybrid and cavities can be replaced by TE_{01} resonant ring.

REC is similar to CLIC as illustrated in Fig. 7. Both use superconducting energy storage cavities. With REC, the klystrons and the energy storing cavities operate at the accelerator frequency. The agents of energy transfer are not the driving beam and the transfer cavities, but a Q_r switch. The advantages are that the storage cavities do not require high gradient, and there are no wake field problems. The disadvantages are that the REC does not take advantage of the larger superconductivity improvement factor due lower frequency, and that it requires the development of high frequency, high power CW amplifiers and low loss, high power, Q_r switches.

A typical design example follows: To obtain a $G = 75$ MV/m gradient in a 50 ns fill time section operating at 17 GHz, we need $P_p = 95$ MW peak power. We can obtain 95 MW with a $P_k = 1$ MW CW klystron and an REC with a compression factor of 100. The REC parameters are:

$$T_b = T_f = 50 \text{ ns}, \quad T_a = 4.95 \text{ } \mu\text{s}, \quad T_2 = 5 \text{ } \mu\text{s}, \quad f_r = 200 \text{ kHz}$$

$$Q_{ca} = 2 \times 10^6, \quad Q_{cb} = 2.73 \times 10^4, \quad Q_0 = 2 \times 10^9$$

$$P_p = M P_k = 95 \text{ MW} .$$

RF ENERGY STORAGE PULSER (RASP)

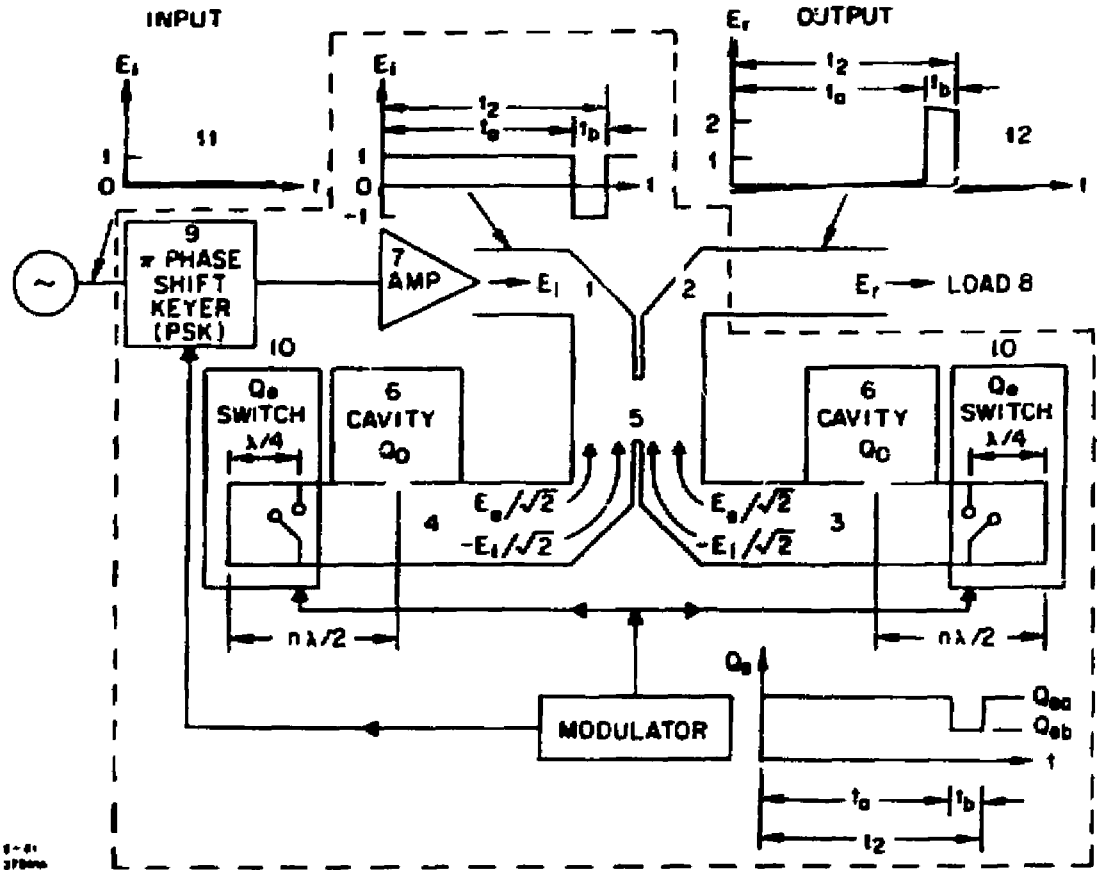

Fig. 6. REC system using 9-dB hybrids.

The above Q_0 can be achieved with niobium-tin superconducting cavities. The compression efficiency, which includes refrigerator power, is 82%.

For a 4 : 1 compression ratio, we do not need Q_e switching. We use PSK only and we have a CW SLED. The reason is that the rate of energy loss during discharge is four times the rate of energy gain during charging. For compression ratios greater than four, the energy stored increases and the efficiency decreases.

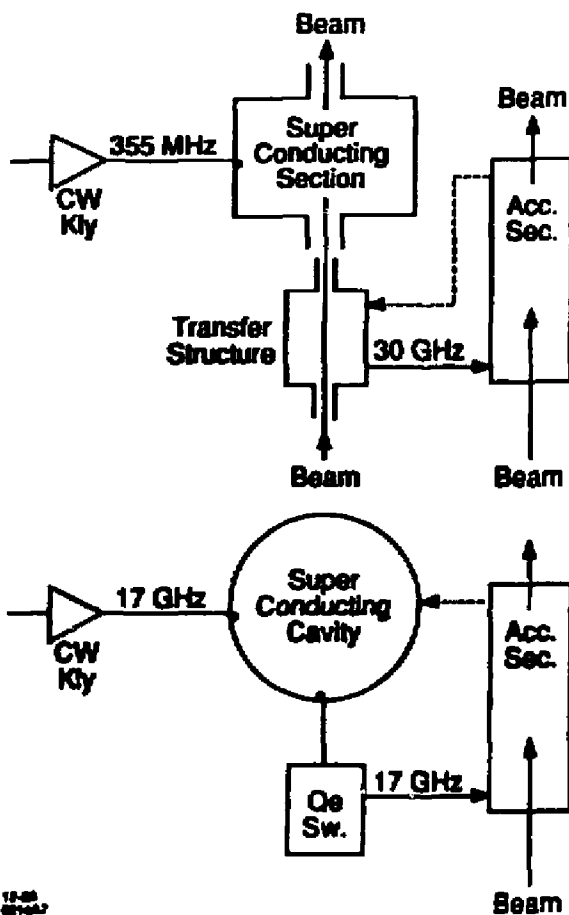
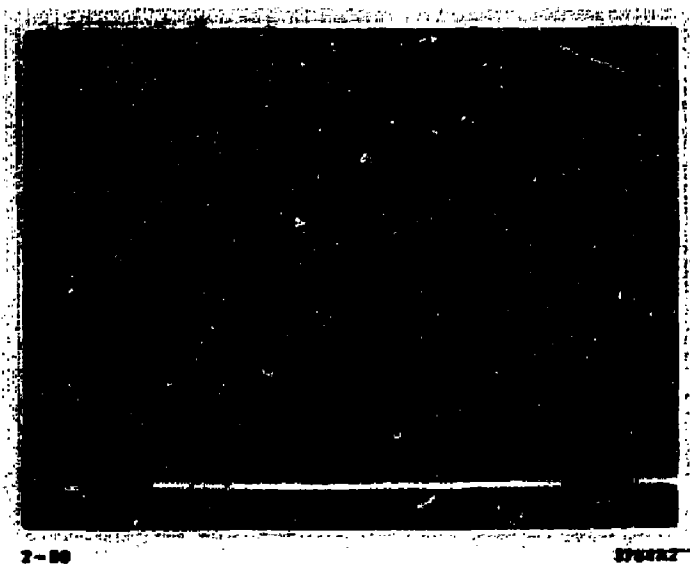

Fig. 7. Comparison of REC and CLIC SYSTEMS.

We obtain reasonable compression efficiencies for compression ratios up to about 10 : 1. An oscillogram of PSK only REC output, with a 7 : 1 compression factor, is shown in Fig. 8.

CONCLUSION

It was shown radio frequency pulse compression is practical and efficient. It can reduce x-ray radiation and can increase the reliability of high peak power generation.



2-88

390227

Fig. 8. Oscillogram of PSK only REC output waveform.

REFERENCES

1. Z. D. Farkas et al., *SLED: A Method of Doubling SLAC's Energy*, Proceedings of Ninth International Conference on High Energy Accelerator, p. 576, May 1976.
2. Z. D. Farkas, *Binary Peak Power Multiplier and its Application to Linear Accelerator Design*, IEEE TRAN. MTT-34, p. 1036, October 1986.
3. Z. D. Farkas, *RF Energy compressor*, IEEE MTT International Microwave Symposium Digest, p. 84-86, SLAC-PUB-1480, February 1980.

DISCLAIMER

This report was prepared as an account of work sponsored by an agency of the United States Government. Neither the United States Government nor any agency thereof, nor any of their employees, makes any warranty, express or implied, or assumes any legal liability or responsibility for the accuracy, completeness, or usefulness of any information, apparatus, product, or process disclosed, or represents that its use would not infringe privately owned rights. Reference herein to any specific commercial product, process, or service by trade name, trademark, manufacturer, or otherwise does not necessarily constitute or imply its endorsement, recommendation, or favoring by the United States Government or any agency thereof. The views and opinions of authors expressed herein do not necessarily state or reflect those of the United States Government or any agency thereof.