



# NBS TECHNICAL NOTE **1134**

U.S. DEPARTMENT OF COMMERCE/National Bureau of Standards

## **Guidelines for the Installation of Solar Components on Low-Sloped Roofs**

## **DISCLAIMER**

**This report was prepared as an account of work sponsored by an agency of the United States Government. Neither the United States Government nor any agency thereof, nor any of their employees, makes any warranty, express or implied, or assumes any legal liability or responsibility for the accuracy, completeness, or usefulness of any information, apparatus, product, or process disclosed, or represents that its use would not infringe privately owned rights. Reference herein to any specific commercial product, process, or service by trade name, trademark, manufacturer, or otherwise does not necessarily constitute or imply its endorsement, recommendation, or favoring by the United States Government or any agency thereof. The views and opinions of authors expressed herein do not necessarily state or reflect those of the United States Government or any agency thereof.**

---

## **DISCLAIMER**

**Portions of this document may be illegible in electronic image products. Images are produced from the best available original document.**

## NATIONAL BUREAU OF STANDARDS

The National Bureau of Standards<sup>1</sup> was established by an act of Congress on March 3, 1901. The Bureau's overall goal is to strengthen and advance the Nation's science and technology and facilitate their effective application for public benefit. To this end, the Bureau conducts research and provides: (1) a basis for the Nation's physical measurement system, (2) scientific and technological services for industry and government, (3) a technical basis for equity in trade, and (4) technical services to promote public safety. The Bureau's technical work is performed by the National Measurement Laboratory, the National Engineering Laboratory, and the Institute for Computer Sciences and Technology.

**THE NATIONAL MEASUREMENT LABORATORY** provides the national system of physical and chemical and materials measurement; coordinates the system with measurement systems of other nations and furnishes essential services leading to accurate and uniform physical and chemical measurement throughout the Nation's scientific community, industry, and commerce; conducts materials research leading to improved methods of measurement, standards, and data on the properties of materials needed by industry, commerce, educational institutions, and Government; provides advisory and research services to other Government agencies; develops, produces, and distributes Standard Reference Materials; and provides calibration services. The Laboratory consists of the following centers:

Absolute Physical Quantities<sup>2</sup> — Radiation Research — Thermodynamics and Molecular Science — Analytical Chemistry — Materials Science.

**THE NATIONAL ENGINEERING LABORATORY** provides technology and technical services to the public and private sectors to address national needs and to solve national problems; conducts research in engineering and applied science in support of these efforts; builds and maintains competence in the necessary disciplines required to carry out this research and technical service; develops engineering data and measurement capabilities; provides engineering measurement traceability services; develops test methods and proposes engineering standards and code changes; develops and proposes new engineering practices; and develops and improves mechanisms to transfer results of its research to the ultimate user. The Laboratory consists of the following centers:

Applied Mathematics — Electronics and Electrical Engineering<sup>2</sup> — Mechanical Engineering and Process Technology<sup>2</sup> — Building Technology — Fire Research — Consumer Product Technology — Field Methods.

**THE INSTITUTE FOR COMPUTER SCIENCES AND TECHNOLOGY** conducts research and provides scientific and technical services to aid Federal agencies in the selection, acquisition, application, and use of computer technology to improve effectiveness and economy in Government operations in accordance with Public Law 89-306 (40 U.S.C. 759), relevant Executive Orders, and other directives; carries out this mission by managing the Federal Information Processing Standards Program, developing Federal ADP standards guidelines, and managing Federal participation in ADP voluntary standardization activities; provides scientific and technological advisory services and assistance to Federal agencies; and provides the technical foundation for computer-related policies of the Federal Government. The Institute consists of the following centers:

Programming Science and Technology — Computer Systems Engineering.

<sup>1</sup>Headquarters and Laboratories at Gaithersburg, MD, unless otherwise noted; mailing address Washington, DC 20234.

<sup>2</sup>Some divisions within the center are located at Boulder, CO 80303.

# Guidelines for the Installation of Solar Components on Low-Sloped Roofs

---

Robert G. Mathey  
Walter J. Rossiter, Jr.

Center for Building Technology  
National Engineering Laboratory  
National Bureau of Standards  
Washington, DC 20234

Sponsored by:  
U.S. Department of Energy  
Office of Solar Applications for Buildings  
Division of Active Heating and Cooling  
Washington, DC 20585

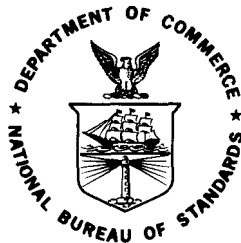

---

U.S. DEPARTMENT OF COMMERCE, Philip M. Klutznick, Secretary  
Luther H. Hodges, Jr., Deputy Secretary  
Jordan J. Baruch, Assistant Secretary for Productivity, Technology and Innovation  
NATIONAL BUREAU OF STANDARDS, Ernest Ambler, Director

Issued November 1980

DISTRIBUTION OF THIS DOCUMENT IS UNLIMITED

*EMB*

**National Bureau of Standards Technical Note 1134**

Nat. Bur. Stand. (U.S.), Tech. Note 1134, 81 pages (Nov. 1980)

CODEN: NBTNAE

**U.S. GOVERNMENT PRINTING OFFICE**

**WASHINGTON: 1980**

---

For sale by the Superintendent of Documents, U.S. Government Printing Office, Washington, D.C. 20402

Price \$4.00

(Add 25 percent for other than U.S. mailing)

GUIDELINES FOR INSTALLATION OF SOLAR COMPONENTS ON  
LOW-SLOPED ROOFS

by

Robert G. Mathey

and

Walter J. Rossiter, Jr.

Guidelines were prepared for the installation of solar collectors and related equipment on low-sloped roofs of commercial and industrial type buildings. The guidelines are concerned primarily with the waterproofing integrity of the roofing system, access to the collectors and roofing, attachment of different types of collector support frames, and safety. Technical information from the literature, building codes, roofing field surveys and acceptable roofing practice provided the basis for the guidelines. The guidelines include recommendations for the design of the solar installation with regard to roofing performance, workmanship during collector installation, and maintenance of roofs with solar components.

A field survey was conducted to inspect the condition of low-sloped built-up roofing systems which were retrofitted with solar collector systems. Literature and field surveys were conducted to identify roofing problems attributed to solar equipment installation on roofs and the effect of the installation on roofing performance. The results of the literature and field surveys are presented. Applicable building codes and related documents were examined to obtain information concerning the effect of the installation of solar components on rooftop safety.

Key words: Collector installation; field survey; guidelines; low-sloped roofs; roofing performance; solar collectors.

## TABLE OF CONTENTS

	<u>Page</u>
ABSTRACT .....	iii
LIST OF FIGURES .....	viii
LIST OF TABLES .....	x
1. INTRODUCTION .....	1
1.1 BACKGROUND .....	1
1.2 SOLAR SYSTEMS AND LOW-SLOPED ROOFS .....	1
1.3 OBJECTIVE .....	3
1.4 SCOPE OF THE PROJECT .....	3
2. GUIDELINES .....	4
2.1 CONDITION OF THE EXISTING LOW-SLOPED ROOFING SYSTEM .....	5
2.1.1 The Roof Components .....	5
2.1.2 Roof Slope and Drainage .....	6
2.2 DESIGN OF THE INSTALLATION .....	7
2.2.1 Structural Requirements .....	7
2.2.2 Wind Loads on Collectors Mounted on Roofs .....	7
2.2.3 Roof Wind Loads .....	7
2.2.4 Roof Snow Loads .....	8
2.2.5 Fire Safety .....	8
2.2.6 Roof Plan .....	8
2.2.7 Architectural Drawings .....	9
2.3 WORKMANSHIP DURING COLLECTOR INSTALLATION .....	9
2.3.1 Membrane Protection Against Damage .....	9
2.3.2 Prevention of Water Penetration .....	10
2.3.3 Installation of Roofing Components .....	10
2.3.4 Debris .....	10
2.3.5 Bitumen Application .....	11
2.4 IMPAIRMENT OF DRAINAGE .....	11
2.5 CLEARANCE .....	11
2.5.1 Clearance Between Collectors and Roofing .....	11
2.5.2 Clearance Around the Collectors .....	12
2.5.3 Clearance Between Heat Transfer Fluid Pipes and Roofing .....	13

TABLE OF CONTENTS (cont.)

	<u>Page</u>
2.6 COLLECTOR SUPPORTS .....	14
2.6.1 Attachment of Collector Supports .....	14
2.6.2 Stub Columns .....	16
2.6.3 Parapet Walls .....	16
2.6.4 Guy Wires .....	16
2.7 FLASHING OF PIPE COLUMN SUPPORTS, PIPES AND CONDUIT .....	16
2.8 SUPPORTS FOR PIPES .....	17
2.9 COMPATIBILITY OF HEAT TRANSFER FLUIDS WITH ROOFING MEMBRANES .....	18
2.10 SAFETY .....	19
2.10.1 Access to the Roof .....	19
2.10.2 Access on the Roof .....	19
2.10.3 Sliding Snow and Ice .....	20
2.11 MAINTENANCE OF ROOFING .....	20
2.11.1 Roof Inspections and Maintenance .....	20
2.11.2 Roofing Repair or Replacement .....	21
2.12 WALKWAYS FOR PROTECTION OF ROOFING AND PIPING .....	21
3. ACKNOWLEDGMENTS .....	30
4. REFERENCES .....	31
APPENDIX A. THE LITERATURE SURVEY .....	A-1
A.1 ATTACHMENT OF SOLAR COLLECTORS TO THE ROOF AND PENETRATIONS IN THE ROOFING .....	A-2
A.2 CLEARANCE BETWEEN COLLECTORS AND ROOFING .....	A-4
A.3 COMPATIBILITY OF COLLECTOR FLUIDS WITH THE ROOFING .....	A-4
A.4 DESIGN .....	A-4
A.5 DRAINAGE OF THE ROOFING .....	A-5
A.6 FIRE SAFETY .....	A-5
A.7 PROXIMITY OF PENETRATIONS TO COLLECTORS .....	A-5

TABLE OF CONTENTS (cont.)

	<u>Page</u>
A.8 RETROFITTING EXISTING ROOFS .....	A-5
A.9 ROOFING PRACTICE .....	A-6
A.10 SAFETY OF WORKERS .....	A-6
A.11 SNOW .....	A-6
A.12 WALKWAYS .....	A-7
A.13 WIND .....	A-7
A.14 REFERENCES .....	A-7
APPENDIX B. MODEL BUILDING CODES AND RELATED DOCUMENTS .....	B-1
B.1 REFERENCES .....	B-3
B.2 MODEL BUILDING CODE ORGANIZATIONS .....	B-3
APPENDIX C. THE FIELD SURVEY .....	C-1
C.1 TYPES OF BUILDINGS, ROOFS AND SOLAR COLLECTOR SUPPORT FRAMES .....	C-1
C.2 SURVEY RESULTS .....	C-2
C.2.1 Condition of Roofing .....	C-2
C.2.1.1 Protection of Roofing During Solar Collector Installation .....	C-3
C.2.2 Roof Slope .....	C-3
C.2.3 Drains .....	C-3
C.2.4 Attachment of Collector Supports and Roof Penetrations .....	C-4
C.2.4.1 Steel Frames .....	C-4
C.2.4.2 Wooden Frames .....	C-5
C.2.4.3 Pipe Penetrations .....	C-6
C.2.5 Clearance .....	C-6
C.2.5.1 Clearance Between Collectors and Roofing.	C-6
C.2.5.2 Clearance Between Piping and Roofing ....	C-6
C.2.5.3 Clearance Around Collectors .....	C-6
C.2.6 Supports for Pipes .....	C-7
C.2.7 Safety .....	C-7

TABLE OF CONTENTS (cont.)

	<u>Page</u>
C.2.7.1 Access to the Roof .....	C-7
C.2.7.2 Access on the Roof .....	C-8
C.2.7.3 Unsafe Conditions .....	C-8
C.2.8 Walkways .....	C-8
C.2.9 Debris on Roof .....	C-9
C.2.10 Maintenance .....	C-9
C.2.11 Design of Solar System Installation .....	C-9
C.3 REFERENCES .....	C-9

LIST OF FIGURES

		<u>Page</u>
Figure 2.1	Installation for Mechanical Equipment Stand or Collector Support Frame .....	22
Figure 2.2	Detail of Column Support for Collector Frame on Steel Structural Member of Building .....	23
Figure 2.3	Detail of Column Support for Collector Frame on a Concrete Structural Deck .....	24
Figure 2.4	Installation of Wooden Supports for Collector Frame on a Solid Curb .....	25
Figure 2.5	Installation of Steel Support for Collector Frame on a Solid Curb .....	26
Figure 2.6	Recommended Clearances for Roof Penetrations from Walls, Curbs and Roof Edges .....	27
Figure 2.7	Detail of Housing for Pipe Penetrations Through Roof Deck .....	28
Figure 2.8	Pipe Roller Support .....	29
Figure C.1	Ponded Water Under Solar Collectors .....	C-11
Figure C.2	Ponded Water Over 2 Inches (50 mm) Deep Around Collectors .....	C-11
Figure C.3	Ponded Water on Roof Surface Extending Under Large Wooden Platform Supporting Solar Reflectors .....	C-12
Figure C.4	Steel Columns Extending Through Roofing Support Collector Frames .....	C-12
Figure C.5	Collector Frames Supported by Stub Columns .....	C-13
Figure C.6	Large Wooden Reflector Frame Supported by Exterior Walls and Column of the Building .....	C-13
Figure C.7	Collector Frame Supported by Wooden Sleeper Mechanically Fastened to the Roof .....	C-14
Figure C.8	Collector Frames with Ends of Steel Beams Supported by Parapet Walls .....	C-14
Figure C.9	Attachment of Collector Support Beam Using a Steel Clip Welded to a Channel which is Bolted to a Parapet Wall .....	C-15

LIST OF FIGURES (cont.)

	<u>Page</u>
Figure C.10 Collector Support Column in a Tilted Pitch Pocket ....	C-15
Figure C.11 Wooden Sleeper Mechanically Attached to Roof .....	C-16
Figure C.12 Ponded Water Above the Bottom Surface of the Wooden Sleepers .....	C-16
Figure C.13 Sleeper Which had Sunk into Asphalt Flood Coat and Aggregate Surfacing .....	C-17
Figure C.14 Pipe Penetration for which the Type of Flashing Was Not Determined .....	C-17
Figure C.15 Excessive Quantity of Asphalt Around Pipe Penetration with Undetermined Type of Flashing .....	C-18
Figure C.16 Pitch Pockets for Pipe Penetrations .....	C-18
Figure C.17 Inadequate Clearance Between Steel Collector Frames and Roofing .....	C-19
Figure C.18 Inadequate Clearance Between Wooden Collector Frames and Roofing .....	C-19
Figure C.19 Piping Located Close to Roof Surface .....	C-20
Figure C.20 Inadequate Clearance Between Front of Collector Array and a Mansard Style Roof Projection .....	C-20
Figure C.21 Vent Pipe Modified to Allow for Solar Collector Installation .....	C-21
Figure C.22 Modification of a Curb Supporting a Ventilator.....	C-21
Figure C.23 Penetration of Collector Support Column at the Edge of the Roof .....	C-22
Figure C.24 Solar Penetration Adjacent to the Edge of the Roof ...	C-22
Figure C.25 Pipe Roller Support Attached to Collector Frame .....	C-23
Figure C.26 Pipe Support Bearing on Roofing Surface .....	C-23
Figure C.27 Collector Array Installed Near Roof Edge .....	C-24
Figure C.28 Installation Having Adequate Access Around Collector Arrays .....	C-24

LIST OF FIGURES (cont.)

	<u>Page</u>
Figure C.29 Fire Wall Penetrated by Solar Piping .....	C-25
Figure C.30 Narrow and Steep Ramp for Passage Over Steel Beam of Collector Frame .....	C-25
Figure C.31 Coated Felt Walkway on Roofing .....	C-26
Figure C.32 Hollow Aluminum Sections Used as Walkways .....	C-26
Figure C.33 Walkway Over Piping .....	C-27
Figure C.34 Debris on Roof From Solar Installation .....	C-27

LIST OF TABLES

Table 2.1 National Roofing Contractors Association (NRCA) Recommended Clearance Under Equipment Frames .....	12
---	----

## 1. INTRODUCTION

### 1.1 BACKGROUND

The U.S. Department of Energy (DoE) proposed rules in 1979 to implement the "Solar in Federal Buildings Demonstration Program" under the National Energy Conservation Policy Act [1]\*. The program is intended to demonstrate active and passive solar heating and solar cooling technology in Federal buildings. The objectives of the "Solar in Federal Buildings Demonstration Program" are: (1) to support efforts to shift from non-renewable energy sources; (2) to stimulate the solar industry; (3) to encourage the continued development and refinement of solar technologies; and (4) to assert the leadership role of the Federal Government in promoting widespread use of technically and economically feasible solar technologies.

The National Bureau of Standards (NBS) provides technical support to the "Solar in Federal Buildings Demonstration Program". A study under the sponsorship of DoE was undertaken at NBS to develop technical information and prepare guidelines on the proper installation of solar system components with regard to the performance of low-sloped roofing systems. This report presents the results of the study. The installation of solar collector system components on low-sloped roofing systems may have a significant impact on the performance of the roof. Improper installation may adversely affect roofing performance, resulting in roof leaks and premature roofing failure. Information obtained in the study may be used to improve design manuals and guide specifications for solar collector installation on existing and new low-sloped roof systems.

### 1.2 SOLAR SYSTEMS AND LOW-SLOPED ROOFS

Solar heating and cooling of buildings offers potential for significant reduction in the use of fossil fuels. The number of installations of solar collector systems on commercial buildings in the United States has increased in recent years. In 1974 the National Solar Heating and Cooling Commercial Demonstration Program was initiated. Since its initiation and through June 1979, 238 solar collector projects had been planned for installation under the program [2]. This program under the direction of DoE provides grants to support the installation of solar systems on commercial buildings. As of June 1979, 104 of the 238 planned demonstration projects had been constructed and were operational [2].

The majority of the solar system installations in the National Solar Heating and Cooling Commercial Demonstration Program has the collector arrays and other system components mounted on the roofs of buildings. Roofs of commercial and industrial buildings are generally low-sloped and waterproofed with bituminous built-up membranes. Other types of membranes have also been used on these roofs. A low-sloped roof may be assumed to have a slope not greater

---

\* Numbers in brackets indicate references listed in Section 4.

than about 1/2 inch per foot (40 mm/m)\* or about 4 percent. Low-sloped roofs offer a number of advantages for the installation of solar collectors including

- Readily available and sufficient space at the building site.
- Generally unshaded location where the collectors may be mounted at the proper orientation towards the sun.
- Normally limited access to restrict unauthorized individuals from interfering with collector operations and to prevent collector vandalism.

Conversely, a number of disadvantages are associated with the installation of solar collectors on low-sloped roofs. The disadvantages include:

- Possible excessive deflection of the roof due to the mass of the collector arrays and the inability of the roofing system to support the mass.
- Increased risk of roofing problems that may lead to premature failure of the roofing. Experience has shown that roofing performance is generally superior for roofs without equipment than those which have equipment mounted on their surfaces. Examples of problems encountered with roofs having solar equipment are roof membrane damage, leaks, moisture build-up within the roofing system, ponding of water on roof surfaces and lack of adequate space for access to the roofing membrane for repair and maintenance.
- Potential for increased roofing repair, maintenance and replacement costs. Increased roofing problems will raise the frequency of roofing repairs and maintenance, and thus the costs for these operations. Roofing costs are expensive, even for buildings which do not have roof-mounted solar components. For example, in the spring of 1980, it was estimated that new roofing costs in the Washington, D.C., area ranged from about 2.75 to 4.00 dollars per square foot; while reroofing costs ranged from 3.50 to 6.00 dollars per square foot [3]. Reroofing costs for buildings with roof-mounted solar equipment will generally be higher than the costs for reroofing buildings without solar equipment, because of the hindrance imposed by the collectors and other solar components.

Comprehensive guidelines are not available to assist solar system designers and installers in the proper installation of solar components on existing low-sloped roofs. The design of solar systems for existing low-sloped roofs has not in general thoroughly considered the interactions of the solar components with the roofing systems nor the effect of the installation of the solar components on roofing performance.

---

\* Values of S.I. Units given in the report are approximate.

### 1.3 OBJECTIVE

The objective of this study was to prepare guidelines for the proper installation of solar equipment on existing low-sloped roofing systems. These guidelines are intended to help provide for adequate performance of roofing systems having retrofitted solar equipment. Low-sloped roofing systems, properly designed, specified, applied and maintained, are capable of functioning adequately without allowing water penetration for 15 to 20 years or more. The installation of solar equipment should not adversely affect nor significantly reduce the expected service life of the roofing system. Although the guidelines deal primarily with the performance of the roofing system, some factors concerning collector performance such as attachment to the roof and wind uplift are also addressed. Such factors are considered important to the performance of both the roofing system and solar system. The guidelines also contain recommendations for evaluating the condition of the existing roofing.

Although the guidelines were specifically prepared for the retrofitting of existing roofing systems, many of the recommendations within the guidelines are applicable to solar installations on new roofing systems. The guidelines should be periodically reviewed to assure that they are consistent with advances in solar technology and roofing technology.

### 1.4 SCOPE OF THE PROJECT

The guidelines were based on information obtained from a review of the technical literature (Appendix A) and model building codes and related documents (Appendix B), and from a field inspection of low-sloped roofs retrofitted with solar systems (Appendix C). Supplemental information was obtained from individuals knowledgeable in the field. The study was limited to the interaction of the solar components and roofing systems and did not include a review of the structural details of attaching the solar system to the structural frame of the building. Discussions were held with roofing contractors, air conditioning contractors, building owners or their representatives, researchers and manufacturers of solar energy systems and roofing materials to determine their views of the performance of roofs having installed solar systems. Seventeen roofs having retrofitted solar equipment were surveyed to inspect the roofing condition and to judge the effect of the solar system installation on the roofing performance.

## 2. GUIDELINES

This section of the report presents guidelines for retrofitting existing low-sloped roofing systems with solar collector systems. The guidelines are short statements consistent with good roofing and building practices and consider the effect of the installation of solar collector systems on roofing performance. A commentary follows each guideline and includes points to consider and steps to be taken to implement the guideline. Lack of consideration of the roofing system during the design and installation of roof-mounted solar collector systems may cause problems. Leaks in the roof, particularly at penetrations, may occur and persist due to the difficulty of repair. The service life of the roof may be significantly shortened because of water penetration into the system. In addition, building energy use may be increased, since wet thermal insulation is less efficient than dry insulation. Also, the repair and replacement of the roofing at the end of its service life may be difficult, if not impossible, because of limited roof access due to the presence of the solar components. In these cases, reroofing costs would be expected to be higher than under normal conditions.

In order to minimize roofing problems from solar system installation, as few solar system components as possible should be mounted on the roof. The guidelines for the retrofitting of existing low-sloped roofs with solar system equipment primarily concern the collector, collector frames including supports and piping, since these components will be present on roofs with solar systems. Whenever possible, other equipment should not be roof-mounted. In general, the guidelines are not intended for the installation of the collectors on dormer type supports. The guidelines deal with liquid solar systems, since this type of system represents the majority of roof-mounted solar installations. Nevertheless, the guidelines are for the most part equally applicable to air systems. It is noted that an alternative to the installation of solar systems directly on low-sloped roofs is the use of a space frame to support the solar system independent from the roof. Space frames may have benefits in cases where the existing roof lacks space for collector installation or cannot adequately support the mass of the collectors. The use of space frames would be limited to low-rise buildings at an appreciable increase in the cost of the solar installations.

The guidelines contain roofing construction details prepared by the National Roofing Contractors Association (NRCA) [4]. Through experience these details have achieved acceptance in the roofing industry. They provide recommendations on techniques or methods to be used for acceptable roofing construction. In some cases the NRCA details were modified herein for specific applications to solar component installation. Some designers of roof-mounted solar collector systems may prefer other construction details. It is suggested that in these cases the alternate details be comparable to those prepared by NRCA.

## 2.1 CONDITION OF THE EXISTING LOW-SLOPED ROOFING SYSTEM

### 2.1.1 The Roof Components

The condition of the existing low-sloped roofing components including membrane, insulation and deck should be determined prior to the design and installation of the solar collector system. Solar system components should only be installed on roofs which are assessed to be in good condition and are expected to provide satisfactory performance (without major repair or reroofing) for 15 years or more.

Commentary: As the sole technique for evaluating the membrane, visual examination often does not indicate the membrane condition. The condition of the membrane surface may appear satisfactory, even though the membrane has deteriorated. Laboratory testing to determine membrane properties may need to be performed for adequate membrane evaluation. The NBS suggested preliminary performance criteria for bituminous membrane roofing may be used as a guide in evaluating these types of membranes [5, 6]. Bituminous membranes, on roofs where solar components are to be installed, should have properties comparable to those of newly-constructed membranes of the same type of materials. In cases where the membrane is found to be in satisfactory condition, but contains minor defects, repairs should be performed. If the remaining life of the membrane is suspect because of age or extensive deterioration, application of a new membrane is warranted. Solar collector system components such as supports, pipes, electrical conduit, equipment supports or mounts and curbs which penetrate the roofing should be installed prior to application of the new membrane, if needed, so that the penetrations may be properly waterproofed during roofing application. If there is a manufacturer's warranty on the roofing system, it is recommended that the manufacturer be consulted prior to cutting openings in the roofing for test cuts or the installation of solar components.

The type and amount of existing insulation and its condition including moisture content should be determined. Nondestructive evaluation techniques such as nuclear backscatter, electrical capacitance and infrared thermography offer methods for moisture detection in roofing systems [7]. Solar collectors should not be installed on roofs containing excessive amounts of moisture in the insulation. In cases where the existing roofing system contains little or no insulation, consideration should be given to increasing the thermal efficiency of the roof through the application of additional insulation. The installation of additional insulation may necessitate the replacement of the existing membrane.

Application of a new roofing system should be performed using acceptable roofing practice such as given in the NRCA "Manual of Roofing Practice" [8]. Membranes of high quality should be selected to provide satisfactory service for at least 15 years or longer. For built-up roofing membranes, at least four plies are recommended. The membranes should have a flood coat and aggregate surfacing unless precluded by special requirements such as those for airport facilities. With regard to metal roofing components, only corrosion-resistant materials should be used.

In new roofing applications, thermal insulation should be well-adhered or mechanically fastened to the deck, when possible. In cases where increased thickness of insulation, 2-4 inches (50-100 mm), is installed, two layers of rigid board insulation are recommended. The first layer should be mechanically fastened, if possible, and the second layer applied with hot bitumen. Joints between insulation boards should be staggered between the two layers.

The presence of solar collectors on low-sloped roofs may hinder the maintenance, repair and replacement of the roofing system. Thus, the costs of maintenance, repair and replacement may be substantially higher for roofs with collectors than for those without collectors. Application of a new membrane prior to installation of the collectors is recommended in cases where the condition of the existing membrane is suspect to avoid the higher replacement costs of the membrane soon after installation of the collectors. Consideration should be given in some cases to the benefits of applying a new membrane after installation of the collectors. In some cases consideration should be given to installing collectors with provisions for their removal during reroofing to minimize costs.

#### 2.1.2 Roof Slope and Drainage

Roofs without adequate slope which pond water are considered unacceptable for the installation of solar components. Steps should be taken before solar component installation to assure adequate drainage of the roof.

Commentary: Drains may be installed at low points of the roof to prevent ponding of water. If the addition of drains is not satisfactory for this purpose, adequate slope should be added to the roofing system. The minimum slope recommended to achieve adequate drainage is 1/4 inch per foot (20 mm/m) or 2 percent. Roof deck deflections should be calculated during design to provide for adequate drainage.

Experience has shown that roofs which drain water perform better than those which retain water on their surfaces. It is important that water drain from the roof as quickly as possible. It is inadvisable to install collectors on roofs which pond water in order to reduce the risk of premature membrane failure and high membrane repair and replacement costs associated with roofs with solar equipment. One method to incorporate slope in an existing roofing system is the use of tapered or sloped insulation.

Observations from field surveys have shown that fungus and plant growth has occurred on shaded areas of roofing under solar collectors where the roof surface remains wet because of the ponding of water. Fungus growth may present a health hazard to some building occupants. Plant growth is damaging to the roofing system, since roots may penetrate the membrane and create paths for water entry into the building.

## 2.2 DESIGN OF THE INSTALLATION

### 2.2.1 Structural Requirements

The load capacity of the roof should be known and be adequate to support the mass of the solar collectors and other system components installed on the roof. In calculating dead loads for solar systems, the mass of the transfer liquid in the collector, liquid in the storage tank (if tank is roof mounted) and liquid in other subsystems and components should be included, except when using dead load to resist uplift or overturning.

Commentary: This provision is included in the HUD Minimum Property Standards (MPS) Supplement [9]. The commentary in the MPS Supplement indicates that heat transfer fluids in liquid systems should be considered as long-term sustained load. Heat transfer fluids also effect seismic forces in a fashion similar to any other dead load. However, it is possible to remove heat transfer fluids, thus the mass of the fluids should not be counted on to resist uplift.

### 2.2.2 Wind Loads on Collectors Mounted on Roofs

Collectors mounted on open racks at an angle to the surface of low-sloped roofs should resist any uplift loads caused by wind. Wind loading should be determined according to the provisions given in the HUD Minimum Property Standards (MPS) Supplement [9].

Commentary: Wind uplift loads on roof-mounted collectors which cause damage to or loss of the solar collector system would also be expected to result in failure of the roofing system. The MPS Supplement gives reference to procedures for the determination of wind loading on collectors. A recent study at NBS has developed procedures for determining wind loading on solar collectors. A report entitled, "Wind, Earthquake, Snow and Hail Loads on Solar Collectors," is in preparation.

### 2.2.3 Roof Wind Loads

Roof loading due to wind effects on flat plate collectors and concentrating collector support structures and/or enclosures should be included in the structural analysis of the roof support framing, and all structural elements influenced by these loads.

Rigid board roof insulation applied during solar component installation should be well-adhered or mechanically fastened to the deck (Section 2.1.1) so that the roofing system will resist uplift forces from anticipated winds.

Commentary: The provision for the structural analysis of the roof support framing and all structural elements influenced by wind loads is similar to a provision for the design of new construction included in the HUD Minimum Property Standards (MPS) Supplement [9]. It is important that uplift resistance be considered in the design of the roof systems. Factory Mutual Loss Prevention Data Sheets 1-7, 1-28, and 1-49 present guidelines and requirements for the design of roofing systems to resist uplift forces [10-12].

#### 2.2.4 Roof Snow Loads

Snow loads should be determined on the basis of local snow conditions and should consider severe drifting between collectors (and under open racks) and accumulation on cover plates. In addition, in cases where the collectors are mounted with their cover plates forming steep slopes, shedding or sliding of snow from the collectors may cause snow to accumulate at their bases which should be considered in the structural analysis of the roof.

Commentary: These provisions are similar to the provisions for the design of new construction included in the HUD Minimum Property Standards (MPS) Supplement [9]. The previously mentioned recent study by NBS has also developed procedures for determining snow loading on solar collectors. The report entitled, "Wind, Earthquake, Snow and Hail on Solar Collectors," is in preparation. Icicles which fall from collectors may damage the roofing. In areas where this may be a problem, the membrane should be protected.

#### 2.2.5 Fire Safety

The effect of the installation of solar collectors on the fire rating of low-sloped roofs should be considered during the design of the solar system. The installation of solar collectors and other system components on the roof should not reduce the fire retardant classification of the roof covering materials below the collectors. Local building codes should be consulted to ascertain that the installation conforms to requirements regarding fire safety characteristics of roofing systems.

Commentary: The HUD Minimum Property Standards Supplement [9] and the CABO recommended requirements for code officials [13] contain the requirement that the solar collectors not reduce the fire retardant classification of the roofing materials. Particular attention should be paid to the addition of combustible materials such as wooden frames and supports for collectors on the roofs, since some local codes may have provisions governing the placement of combustible materials on roofs.

#### 2.2.6 Roof Plan

A drawing of the roof plan should be prepared during the design of the collector system installation.

Commentary: The roof plan should show all penetrations and obstructions to the collector system installation such as vent pipes, drains, expansion joints, ventilators, skylights, penthouses, and parapet and other types of walls. The location of the collector arrays on the roof should be indicated on the drawing. Collectors should not be installed in close proximity to the perimeter of the roof or existing roof penetrations (Section 2.5.2). Frames supporting collectors should not extend across expansion joints in the roof, unless provisions are made to accommodate thermal movement of the frames. If vertical supports cannot accept lateral movement, roof failures or even structural damage may ensue [14].

The recommendation that a roof drawing be prepared concerns the selection of the most suitable location for collector placement with regard to installation without hindrance from obstructions and access to the collectors and adjacent roofing for proper maintenance and repair. Some locations on the roof may be more suitable than others and the availability of a roof drawing will assist in the determination of suitable location. In some situations, it may not be possible to mount collectors on existing roofs so that the collectors are suitably located free from all penetrations, expansion joints and other obstructions. In these cases, a balance between the energy-savings achieved through the installation of collectors having limited access and high future maintenance and repair costs of both the collectors and roofing should be considered.

### 2.2.7 Architectural Drawings

Architectural drawings for solar collector installations should include accurate and complete details of penetrations and flashings.

Commentary: The recent assessment of drawings used for collector system installation in the National Solar Heating and Cooling Commercial Demonstration Program has shown that drawings of details are not always accurate and complete [14]. Poor drawings of details may lead to inadequate application of penetrations and flashings and result in roof failure at these locations. The number of penetrations and curbs may be reduced by using longer spans to support collector frames. It has been emphasized in the literature that it is important to detail roof penetrations accurately and completely [14].

Accurate and complete details of roof penetrations and flashings are necessary for their proper installation. Without these details it is often left to the installers and applicators to decide how it should be done.

## 2.3 WORKMANSHIP DURING COLLECTOR INSTALLATION

### 2.3.1 Membrane Protection Against Damage

Installation of the solar system components should be accomplished in such a manner to prevent abuse and damage to the existing roof membrane.

Commentary: Protection boards or other applicable materials should be placed on top of the existing membrane to protect it from sources of damage such as foot traffic, the placement of ladders, impact due to dropped tools and construction materials, and puncture due to sharp objects. Damage to the membrane including punctures, tears and cuts should be repaired immediately to prevent water entry into the roofing system. If the repairs are considered to be temporary, the repaired areas of roofing should be marked with paint or other suitable means so that these areas may be readily located at the time of final repair. The installation of solar collectors on bituminous built-up roofing systems should not occur at temperatures below 40°F (4°C), since the built-up membrane may be brittle below this temperature. Damage to the brittle membrane may result from foot traffic on the roof during the solar component installation. Solar system components should not be placed or stored on the

roof during installation in such a manner as to cause excessive concentrated loads which may damage the membrane. After installation of the solar collector system, the roofing should be carefully inspected to assure that accidental damage to the membrane has not gone undetected and may be properly repaired.

Collectors should not be placed or stored for extended periods of time directly on the roofing membrane during installation. They may become excessively hot due to absorbed solar radiation under stagnation conditions. The heat generated in this case may damage the roofing membrane.

The installation of solar collectors on low-sloped roofs has the potential to result in extensive and costly damage to the roof. Roof damage may increase the costs of solar system installation because of needed roof repairs, cause water to penetrate into the building, and result in premature deterioration of the roofing system. All tradespersons involved in the installation of the solar collectors should be aware of the necessity to avoid abuse of the roofing.

### 2.3.2 Prevention of Water Penetration

The roofing system should be protected from the entry of water at all times during collector installation.

Commentary: Collector supports should be flashed immediately after their attachment to the structural frame of the building. Roof penetrations for other system components such as electrical conduit and pipes should also be flashed immediately after installation. The entry of moisture into roofing systems is a major cause of premature failure [7]. In order to keep the roofing system protected from the entry of water at penetrations, temporary flashing may be necessary. Temporary flashing should be replaced with permanent flashing as soon as possible. The immediate installation of flashing provides protection from unexpected sources of moisture such as storms and dew.

### 2.3.3 Installation of Roofing Components

Roofing contractors should apply permanent roofing membranes, flashings and other roofing system components.

Commentary: Only temporary roofing work necessary for waterproofing during solar system installation should be performed by tradespersons other than roofing contractors. In retrofit installations the flashing work is often done poorly by plumbers or steel erectors [14]. Therefore, it is recommended that this work be done by roofing contractors. Lack of skill on the part of the installers may result in poor installation [15].

### 2.3.4 Debris

Debris remaining on the roof from the solar equipment installation should be removed at the completion of the construction.

Commentary: Debris on the roof may be a source of puncturing or other damage to the membrane. Debris may clog drains or reduce the rate of drainage resulting in unwanted accumulation of water on the surface of the roof.

### 2.3.5 Bitumen Application

In conducting bituminous roofing operations such as the flashing of collector supports and repair of accidental membrane damage, care should be exercised to prevent the splatter of hot bitumen on collector cover plates.

Commentary: The possibility of splatter of hot bitumen on collector cover plates appears remote. Nevertheless, this guideline is given to increase the awareness of roofing mechanics that bitumen on a cover plate will reduce the efficiency of the collector. In addition hot bitumen splattering on some plastic cover plates may result in damage to the cover plate. Bitumen on cover plates should be removed. Solvents used for this purpose may damage some plastics used for cover plates. The effect of solvents on cover plates should be determined prior to their use.

## 2.4 IMPAIRMENT OF DRAINAGE

The installation of the solar collectors should not affect the capacity of the roofing system to drain water completely.

Commentary: Collector supports should not interrupt drainage. Long equipment supports or curbs may act as unwanted waterstops. Ponding of water must be avoided. Continuous curbs covering long expanses of roofing used to mount collectors and other system components should not be oriented perpendicular to the slope of the roof, since the curbs may retain water on the roof surface. Curbs covering long expanses and oriented perpendicular to the slope of the roof should be divided into small sections, about 4 feet (1.2 m) in length, to assure adequate drainage. Equipment supports or curbs oriented in the direction of the slope of the roof may be of any length provided that they do not extend across valleys.

## 2.5 CLEARANCE

### 2.5.1 Clearance Between Collectors and Roofing

Adequate clearance should be provided between the bottom of the solar collectors and/or the collector frames to allow unobstructed inspection, maintenance, repair and replacement of the roofing system below the collectors. The minimum distance for adequate clearance should generally be within the range of 24 to 30 inches (600-750 mm).

Commentary: Inadequate clearance between collectors and/or collector frames may result in improper maintenance and repair of the roofing system, and high maintenance and repair costs due to insufficient work space. Reroofing costs will also be higher than normally encountered if sufficient work space is not available for roofing mechanics to remove existing roofing and apply new

roofing under the collectors. In extreme cases of insufficient clearance, the collectors and other system components may have to be dismantled before reroofing operations may begin. In the field survey conducted to provide background information for preparation of this report, one roof without adequate clearance under the collectors and in need of renovation was inspected. In this case, roofing contractors indicated that the solar collectors would have to be removed prior to the beginning of reroofing operations. It is anticipated that even when 24 to 30 inches (600-750 mm) minimum clearance is provided between collectors and/or collector frames and the roof surface, reroofing operations would be impeded due to the collector and support frames. In particular, mechanical equipment used to apply hot bitumen and bituminous felts would be precluded and bitumen and felt application would be performed manually.

The National Roofing Contractor Association (NRCA) has recommended minimum clearances between equipment frames (stands) and roof surfaces to allow for proper roofing. The NRCA recommended clearances vary according to the width of the equipment frame, as shown in Table 2.1 and Figure 2.1. The provision for minimum clearance given in these guidelines is based on the NRCA recommended clearances. In general, the widths of frames supporting solar collectors range from about 3 to 5 feet (0.9 to 1.5 m). If collector frames having other widths are installed, the clearance under the frames may vary according to the NRCA recommendations. The minimum recommended distances for adequate clearance may be less than the 24 to 30 inches (600-750 mm) if provisions are provided for easy removal of the collectors (Section 2.1.1).

Table 2.1 National Roofing Contractors Association (NRCA) Recommended Clearance Under Equipment Frames

Width of Frame		Clearance Between Frame and Roofing	
in	mm	in	mm
up to 24	up to 600	14	350
25 to 36	625 to 900	18	450
37 to 48	925 to 1200	24	600
49 to 60	1225 to 1500	30	750
61 and wider	1525 and wider	48	1200

Solar collectors located close to the roof surface tend to act as snow fences, when they are oriented at an angle to the roof surface and perpendicular to the wind direction [16]. Adequate clearance between collectors and the roof surface reduces the risk of snow accumulation under the collectors.

### 2.5.2 Clearance Around the Collectors

Adequate clearance should be provided between the perimeter of arrays of collectors and roof perimeters, roof penetrations and equipment. To provide

adequate clearance a minimum distance of 24 inches (600 mm) between the perimeters of the collector array and roof perimeter, penetrations and equipment is recommended. Solar collector supports and collector panels should not be installed so as to extend beyond the edge of the building.

Commentary: Adequate clearance around the perimeter of collector arrays is considered important for a number of reasons. First, clearance is needed to provide for safe installation of the collectors and access to them for maintenance. Second, space is needed to allow for proper installation, maintenance and repair of flashing of equipment supports and curbs used to mount collector frames. The National Roofing Contractors Association (NRCA) has recommended that a 12 inch (300 mm) clearance be provided between multiple pipes or between curbs and walls and pipes. The NRCA recommendation only concerns the proper flashing of pipes and curbs and not installation and maintenance of solar collectors. Third, the clearance provides space for the application of walkways on the roof surface around the perimeter of the collector arrays.

Collector arrays extending beyond the building edge are intended to allow for placement of an adequate number of collectors on roofs which would otherwise have insufficient available space for solar system installation. It has been reported that the addition of complex structures which extend beyond the edge of the building for collector installation will probably never be cost-effective [14]. Access walkways for maintenance of collectors extending beyond the building edge must also be provided and contribute to the system installation costs.

It is realized that because of the location of existing penetrations, provisions for adequate clearance around collector arrays may not always be possible when retrofitting some roofs with solar systems. In these cases, the designer, building owner or other individuals responsible for the solar system installation should be aware that a lack of adequate clearance may result in decreased roofing performance and higher costs for roof maintenance, repair and replacement.

### 2.5.3 Clearance Between Heat Transfer Fluid Pipes and Roofing

A minimum distance of 14 inches (350 mm) should be provided between the heat transfer fluid pipes including thermal insulation with its protective covering and the surface of the roofing system.

Commentary: Adequate clearance between the heat transfer fluid pipes including thermal insulation with its protective covering and the surface of the roofing is needed for proper maintenance, repair and replacement of the roofing. This provision is based on the National Roofing Contractors Association (NRCA) recommendation concerning clearance between the roof surface and equipment frames less than 24 inches (600 mm) in width (Table 2.1). Less clearance is allowed under pipes than under collectors or collector frames since the area of roofing is considerably less under pipes. The pipes are considered to impose less hindrance to maintenance and reroofing than the collectors and frames. Drains systems may have design requirements whereby sections of pipe may be situated a considerable distance below

the bottom of the collectors and/or collector frames to achieve adequate slope. One quarter inch per foot (20 mm/m) slope is normally recommended to maintain positive drainage of draindown piping. The required slope should be considered during system design to assure that the heat transfer fluid pipes are not less than 14 inches (350 mm) above the roof surface. Observations from the roof survey indicated that in some solar system installations, sections of piping have been situated on the surface of the roofing.

## 2.6 COLLECTOR SUPPORTS

### 2.6.1 Attachment of Collector Supports

Supports for solar collector frames should be securely attached to the roof structure and properly waterproofed.

Commentary: Solar collectors are generally supported by either steel, wood or combination of steel and wood structural frames. Aluminum collector frames are used to a lesser extent. Steps to implement this guideline for the various types of collector frames are given as follows:

#### ° Steel Collector Frames

The steel collector frames should be supported by steel pipe columns that extend through the insulated roofing system to the structural frame of the building. Other shapes of steel support columns can be used; however, pipe columns allow for relatively easy installation of sleeve type flashing (Figures 2.1, 2.2 and 2.3). The concentrated load from the collector support frames (pipe columns) should be located directly over columns or heavy girders in the structure of the building. A steel anchor plate should be attached to the bottom of the pipe column. This anchor plate should be connected to the steel or concrete structural members of the building. On concrete decks or slabs grout should be used under the anchor plate to insure uniform bearing and leveling. For wooden decks, concentrated loads from pipe columns should be supported by roof joists or bracing between joists and not by the unsupported wooden deck between joists.

#### ° Wooden Collector Frames

Wooden collector frames should be attached to an equipment support or solid curb that extends at least 8 inches (200 mm) above the roofing surface as shown in Figure 2.4. Manufactured curbs may be used provided that they perform as well as the type of solid curb shown in Figure 2.4. The solid curb consists of at least three wooden planks, nominal 2 x 10 inch or larger, oriented vertically and extending along the top of the roof system. The planks are attached to each other and to the roof system. Bituminous base flashing and metal cap flashing are installed over the top of the wooden planks. The wooden collector frames should bear on a nominal 2 inch thick wooden plank having a width less than the equipment support frame and attached to the equipment support with bolts or lag screws. A neoprene rubber pad should be installed between the bearing plank and cap flashing. The bolts or lag screws set in an elastomeric sealant extend through the

metal cap flashing of the equipment support. Care should be taken to prevent water from entering the equipment support through the metal cap flashing. The legs of the wooden collector frames should be attached to the nominal 2 inch thick wooden bearing plank but the leg fasteners should not extend through the metal cap flashing. Wood used in exposed applications should be naturally rot-resistant or pressure treated.

° Steel and Wooden Collector Frames

For some installations the least expensive support may mix wood and steel. In one case the primary beams may be wood and the collector frame supports (legs) may be steel. As in the case of the steel frames described above, steel pipe columns should be used, since they are round and allow for effective and relatively easy installation of sleeve type flashing.

In another case the steel supports may be attached directly to wooden equipment supports or solid curbs (Figure 2.5). A wooden bearing plank used with wooden collector frames may not be needed for this type of attachment. A neoprene rubber pad should be installed between the base or anchor plate of the support and cap flashing.

° Aluminum Collector Frames

Aluminum collector frames consisting of tubes, angles and other shapes may be attached to the roof through wooden equipment supports or solid curbs as noted above.

The guidelines for the installation of solar components on roofs deal essentially with the non-structural portion of the roofing system. Therefore, it is recommended that a structural analysis be carried out to determine if the anticipated loads applied to the structural frame of the building are in the allowable range (Section 2.2.1) and do not result in excessive roof deck deflection (Section 2.1.2). Retrofit supports must often be located at irregular intervals because collectors need to be oriented with regard to the sun.

Proper details for supporting solar collector frames allow for roof maintenance around and along the supports. They also provide secure collector attachment and protection against penetration of water into the roofing system. The attachment of solar collectors with wooden planks or sleepers directly to the roofing system by mechanical fasteners or by ballasting in place is not recommended. The use of pitch pockets for waterproofing collector supports is also not recommended (Section 2.7.1).

The continuous wooden equipment support or solid curb is preferred in lightweight roof systems since the weight of the solar collectors can be spread over more supporting members. Where heavy structural systems are used to support the collectors, or where the load can be concentrated over a column or heavy girder in the structure of the building, pipe column type of support is preferred.

### 2.6.2 Stub Columns

Stub columns which extend above the surface of the roofing membrane and allow for proper flashing may be used as supports for solar collector frames.

Commentary: A stub column height of at least 8 inches (200 mm) above the roofing is required for proper flashing. In cases where stub columns extend less than 8 inches (200 mm) above the surface of the roofing, an extension may be added to provide for adequate flashing. In order to obtain recommended clearance between collectors and roofing, collector frame supports (legs) may have to be attached to the stub columns.

### 2.6.3 Parapet Walls

Solar collector frames should not be supported by parapet walls.

Commentary: Movement of the collector frame due to wind and thermal expansion and contraction may be transferred to the parapet wall, resulting in damage to the wall and the base flashing. In cases where the ends of the collector frame beams are solidly anchored to parapet walls, structural damage may occur due to movement of the frame beams.

### 2.6.4 Guy Wires

Guy wires, used to brace solar collector frames against uplift, should not be fastened directly through the roof membrane to the structural deck with eye bolts or other methods of attachment. Guy wires should be connected to properly flashed penetrations such as sealed pipe columns, curbs or stub columns.

Commentary: Attachment of guy wires directly to the roof deck punctures the membrane and presents a potential source of water penetration into the building. Pitch pockets or elastomeric sealants applied around guy wire attachments which penetrate membranes are not suitable to prevent leaks.

## 2.7 FLASHING OF PIPE COLUMN SUPPORTS, PIPES AND CONDUIT

Flashings for pipe column supports and heat transfer fluid pipes with the roofing membrane should be accomplished using pipe sleeves having a rectangular base flange that extends at least 4 inches (100 mm) from the vertical circular portion of the sleeve.

Commentary: Figures 2.2, 2.3 and 2.6 give examples of pipe sleeves for flashings. The sleeves should be durable metal such as aluminum, copper or lead. An important consideration in the selection of the type of metal is galvanic action between the sleeve and the pipe column or pipe. Watertight umbrellas should be attached to the pipes above the tops of the sleeves using a draw band and elastomeric sealant to prevent water from entering between the pipe and the sleeve (Figures 2.1, 2.2 and 2.3). Galvanic action between the umbrella and sleeve should also be considered.

Pitch pockets are not recommended for waterproofing between the roofing membrane and pipes extending through the roofing system. Pitch pockets require constant inspection and maintenance for long-term satisfactory performance. Sealants are also not recommended for waterproofing at these locations, since they may not be reliable over the expected life of the roofing [15].

Penetrations for heat transfer fluid pipes may alternatively be waterproofed with a wooden curb and metal hood housing. In cases where more than one pipe penetrates the roof through an opening, the use of a housing for waterproofing is recommended in lieu of the use of pipe sleeves. A satisfactory method of grouping piping that must come up above the roofing surface is illustrated in Figure 2.7. In order to improve this type of detail, sleeves instead of collars should be sealed to the pipes extending through the sheet metal hood [14]. In addition, insulation should be provided to prevent energy loss at the roof opening [14]. Flexible type insulation is suitable for this purpose.

Improper flashing of pipe column supports and pipe penetrations may result in long-term problems of roof leaks at these locations. Acceptable flashing details are a necessity to avoid these problems, since flashings are the most vulnerable location in the roofing system for water penetration into the building.

Thermal insulation and accompanying protective covering, applied to heat transfer fluid pipes to minimize heat loss, should not extend through the roof. It should be terminated above the roof at the pipe flashing. Thermal pipe insulation and protective covering which penetrate the roof present a pathway for water entry into the building. It was observed during the field survey that the pipe insulation and covering were generally not watertight.

Pipes penetrating the roofing system should be at least 3 feet (0.9 m) away from roof drains and there should be at least 12 inches (300 mm) clearance between pipe penetrations. There should also be 12 inches (300 mm) clearance between the lower edge of cants and the pipes. These clearances are recommended so that adequate space is provided to apply built-up roofing or other membranes properly over sleeve flanges around the pipes.

All wires extending through the roof should be in metal pipes (conduit) so that the pipes containing the wiring may be flashed properly. It is recommended that penetrations through the roof for wiring be kept to a minimum. Careful selection should be made of locations for wire penetrations. As many wires as possible should be placed in one pipe or conduit extending through the roof.

## 2.8 SUPPORTS FOR PIPES

Heat transfer fluid pipes should be supported by the collector frames whenever possible. Where pipes need to extend along the roof, they should extend along the roof as short a distance as possible.

Commentary: Pipes should be supported by rollers attached to hangers from the collector frame. Insulation covering the pipes should be protected from concentrated loads by using rigid insulation such as foam glass or by an

insulation protector such as a shield. If needed, dielectric protection should be provided between the waterproofing and pipe supports. The pipes should be a minimum distance of 14 inches (350 mm) above the roof (Section 2.5.3).

Extending pipes along the roof as short a distance as possible is a good safety practice. This practice does not impair access to the roof and it also reduces problems with the piping system associated with maintaining the roofing and protecting pipes from foot traffic. For pipes extending from one array of collectors to another and those extending along the roof to a storage tank located below the roof, the pipe roller support recommended by NRCA (Figure 2.8) is preferred. This type of pipe support allows for thermal expansion and contraction of pipes without roof damage.

Pipes may be temporarily supported by the roofing membrane using a nominal 2 inch thick piece of wood at least 12 x 12 inch (300 x 300 mm) in size as a bearing block and a metal or wooden vertical support extending upward from the bearing block to the pipe. The bearing block rests directly on the roofing membrane. Allowing the bearing block to rest freely on the roof is preferable to attaching it to the roof. Bolting the block or mechanically fastening it to the roof is not recommended because leaks may result.

## 2.9 COMPATIBILITY OF HEAT TRANSFER FLUIDS WITH ROOFING MEMBRANES

Heat transfer fluids should be selected and used to avoid damage to the roofing membrane.

Commentary: Experience has shown that leaks in the piping systems of solar collectors have resulted in the spill of heat transfer fluids onto roof membrane surfaces. Heat transfer fluids may also be discharged on the roof through pressure relief valves. Some heat transfer fluids have not been compatible with the membrane materials, and softening and dissolving of roofing bitumens has resulted. Since most existing industrial and commercial buildings have been roofed with bituminous built-up roofing, the compatibility of collector fluids with roofing bitumens should be considered. Consideration should also be given to the toxicity and disposal of heat transfer fluids.

In cases where solar systems are mounted on buildings with roofing systems having other than bituminous built-up membranes, the compatibility of the fluid with these membranes should also be considered. Examples of such membranes include those constructed from single-ply elastomeric, plastomeric and modified bituminous materials. It is noted that the French Centre Scientifique et Technique du Batiment (CSTB) general rules for solar equipment installation allow incompatible heat transfer fluids to be used provided that a catch basin having a drain connected with rainwater drains is placed under the collectors to keep fluid from spilling on the membrane in the event of a leak [17]. When catch basins having drains are used the heat transfer fluid must conform to health regulations [17].

## 2.10 SAFETY

### 2.10.1 Access to the Roof

Roofs over three stories in height should have a means of access to provide for collector cleaning and maintenance.

Commentary: The requirement that access be provided for roofs over three stories in height is included in the HUD Minimum Property Standards (MPS) Supplement [9]. The MPS Supplement considers that the use of portable ladders is not adequate for reaching roofs over three stories in height. Roof access may be provided through stairways or ladders permanently constructed either on the inside or outside of the building. Stairways or ladders on the inside of the building may require that an egress to the roof such as a penthouse or hatch be provided. Construction of the egress to the roof should not adversely affect the structural capability of the roofing system. Some local codes may require inside access to the roof in cases where equipment is installed on the roof. Stairways or ladders permanently mounted on the outside of the building for roof access should be equipped with acceptable safety accessories such as guardrails, handrails and cages.

In many cases the installation of a permanent means of access to the roof may be warranted if the building is two stories or greater in height. Solar collectors on the roofs of buildings require frequent periodic inspection and maintenance. In some cases individuals responsible for the inspection and maintenance may be unfamiliar with climbing ladders to reach roofs. The use of portable ladders even in these cases may be inadequate and pose a risk to their safety. Experience obtained in surveying roofs for the preparation of this report indicated that access to roofs without permanent stairways or ladders was at times gained from ladders which were undersized and had questionable safety characteristics. Collectors mounted on roofs without permanent access may receive less than required periodic inspection and maintenance because of lack of accessibility to the roof.

Good safety and security practice prevents access to the roof by unauthorized persons. Examples of means to prevent unauthorized access to roofs are locked interior doors and hatches, locked permanent exterior ladders, and fences with locked gates at the base of exterior ladders.

### 2.10.2 Access on the Roof

The installation of solar collector systems on low-sloped roofs should not impair the normal movement of occupants of the building or emergency personnel.

Commentary: This guideline is a provision included in the HUD Minimum Property Standards (MPS) Supplement [9]. According to the MPS Supplement special consideration should be given to the effect of the configuration of roof-mounted collectors on fire-exiting, fire fighting or emergency rescue. In this regard, the use of long expanses of framing members to support a number of successive collector arrays should be avoided whenever possible.

Consideration should be given to the effect of solar collector location on the safety of workers who maintain and repair collectors. Access should be provided for maintenance workers around the entire perimeter of the collector arrays. Experience has indicated that some collector arrays are situated at the edge of the building or extend beyond the building edge. In these cases, access to some collectors for maintenance was found to be limited without the use of ladders or other means.

### 2.10.3 Sliding Snow and Ice

In areas which have a snow load of 20 pounds per square foot (958 Pa) or greater as indicated by requirements given in local codes, provisions should be made over entrances and locations of pedestrian and vehicular ways to restrain or deflect snow and ice masses which may slide off elevated solar system components.

Commentary: This provision for protection of pedestrian and vehicular ways against sliding snow and ice is included in the HUD Minimum Property Standards (MPS) Supplement [9]. Commentary included in the MPS Supplement indicates that solar system components may often include smooth slippery surfaces located in elevated positions at steep angles. These elements may heat up rapidly and loosen masses of snow or ice which may slide-off. Means should be provided to prevent a hazard to people or property. Methods such as deflectors, restraints, low friction materials, or design of "safe fall" areas (pedestrian or vehicular ways spaced away from the building) should be considered. Deflectors and restraints should be able to support heavy snow loads including impact from falling snow and ice.

## 2.11 MAINTENANCE OF ROOFING

### 2.11.1 Roof Inspections and Maintenance

Roof inspections should be performed at regular intervals and repairs made to the roofing system as soon as they are needed.

Commentary: A regular inspection and maintenance schedule should be established. It is recommended that inspections be conducted at least in the spring and fall of the year. The roofing inspection should be conducted by a roofing contractor. If the visual roof inspections indicate breaks or openings in the roofing membrane or in areas of flashing, it may be advisable to have nondestructive evaluations conducted as noted in Section 2.1.1 to detect if water is present in the roofing system.

Because of the difficulty of repair and replacement of roofing on buildings having solar collector systems, it is important that the roofing be maintained at frequent regular intervals. Roofing inspections and immediate repair of roofing, if needed, will help enable the roofing to perform satisfactorily over its intended service life.

### 2.11.2 Roofing Repair or Replacement

Needed repairs or replacement of sections of roofing or flashing identified during maintenance inspections should be completed as soon as possible.

Commentary: The repair or replacement work should in general be performed by a roofing contractor. In the repair and replacement of roofing and flashing, areas of the roofing in good condition should be protected from foot traffic and the storage of materials. The areas of roofing or flashing being repaired or replaced should be completed the same day as work was initiated. If for some reason work can not be completed the same day, roofing areas where work is in progress should be protected from the entry of water into the roofing system until work can be resumed.

### 2.12 WALKWAYS FOR PROTECTION OF ROOFING AND PIPING

Walkways should be provided on areas on roofing which receive frequent foot traffic due to periodic inspection and maintenance of roof-mounted collector system components.

Commentary: Walkways provide membrane protection from foot traffic. Roof areas where walkways should be installed include: the perimeter of arrays of solar collectors; pathways leading from the roof access point such as a hatch, ladder or penthouse to the solar collectors; pathways from the solar collectors to other roof-mounted solar system components; and, the perimeter of other solar system components which are roof-mounted. Ramps or stairs over pipes and expansion joints provide for safe worker passage over these areas without damage to them. The use of asphaltic planking is one method for the installation of walkways on built-up roofing systems.

Walkways should not be placed on areas of built-up bituminous membranes which contain blisters, since foot traffic on the blisters would be expected to puncture them. Blisters should be repaired prior to installation of the walkways. Installation of walkways should not impair roof drainage.

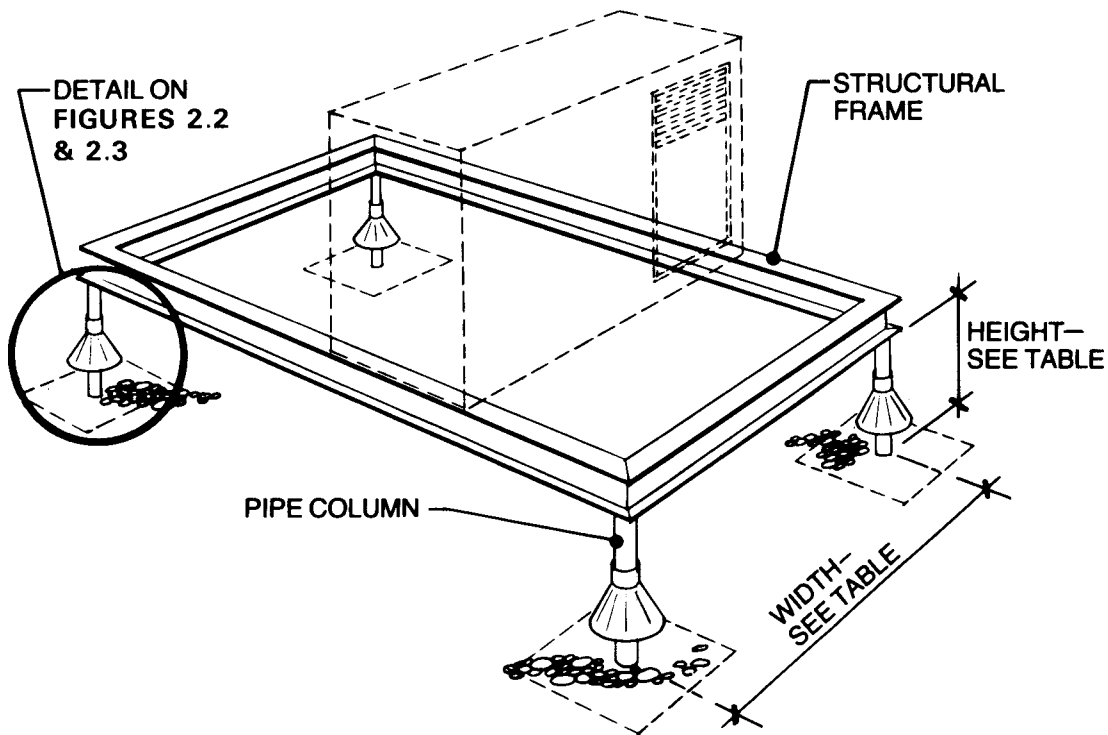

WIDTH OF EQUIPMENT	HEIGHT OF LEGS
UP TO 24"	14"
25" TO 36"	18"
37" TO 48"	24"
49" TO 60"	30"
61" AND WIDER	48"

**NRCA NOTE:**

This detail is preferable to detail "D" (Figure 2.5) when the concentrated load can be located directly over columns or heavy girders in the structure of the building. This detail can be adapted for other uses, such as sign supports.

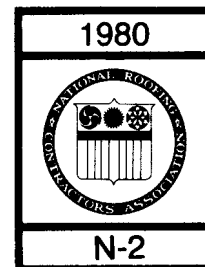
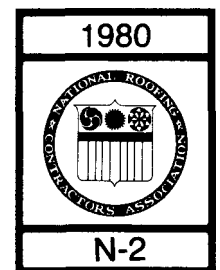
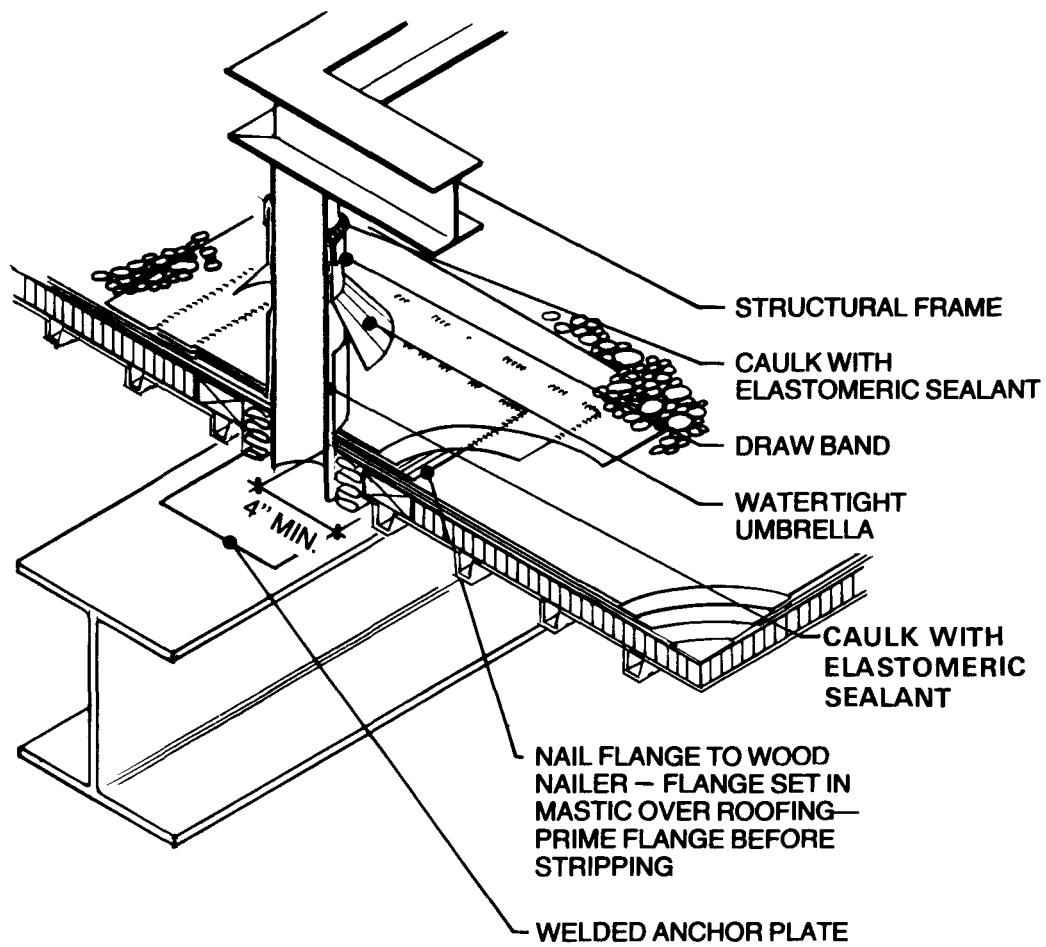
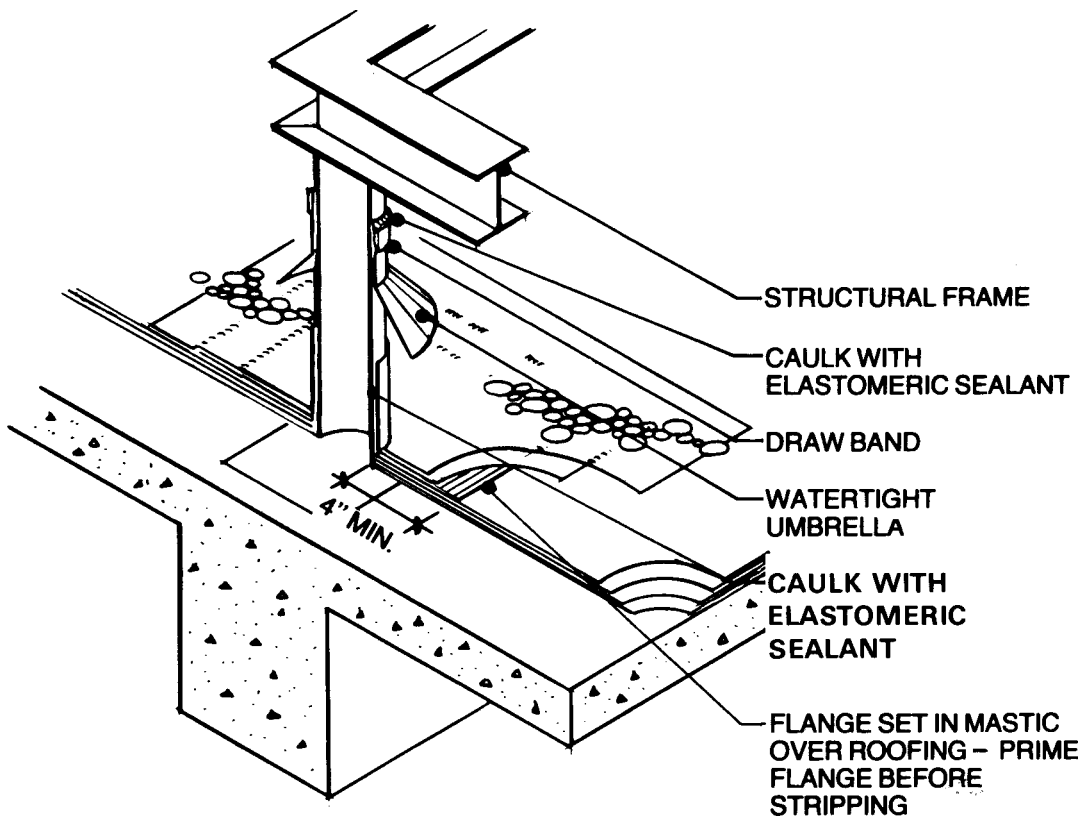

Figure 2.1 Installation for Mechanical Equipment Stand or Collector Support Frame



Modified by NBS

Figure 2.2 Detail of Column Support for Collector Frame on Steel Structural Member of Building



**NBS NOTE:**  
 Present roofing practice normally includes insulation  
 in the roofing system.

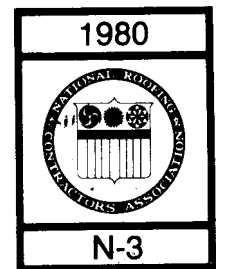

Modified by NBS

Figure 2.3 Detail of Column Support for Collector  
 Frame on Concrete Structural Deck

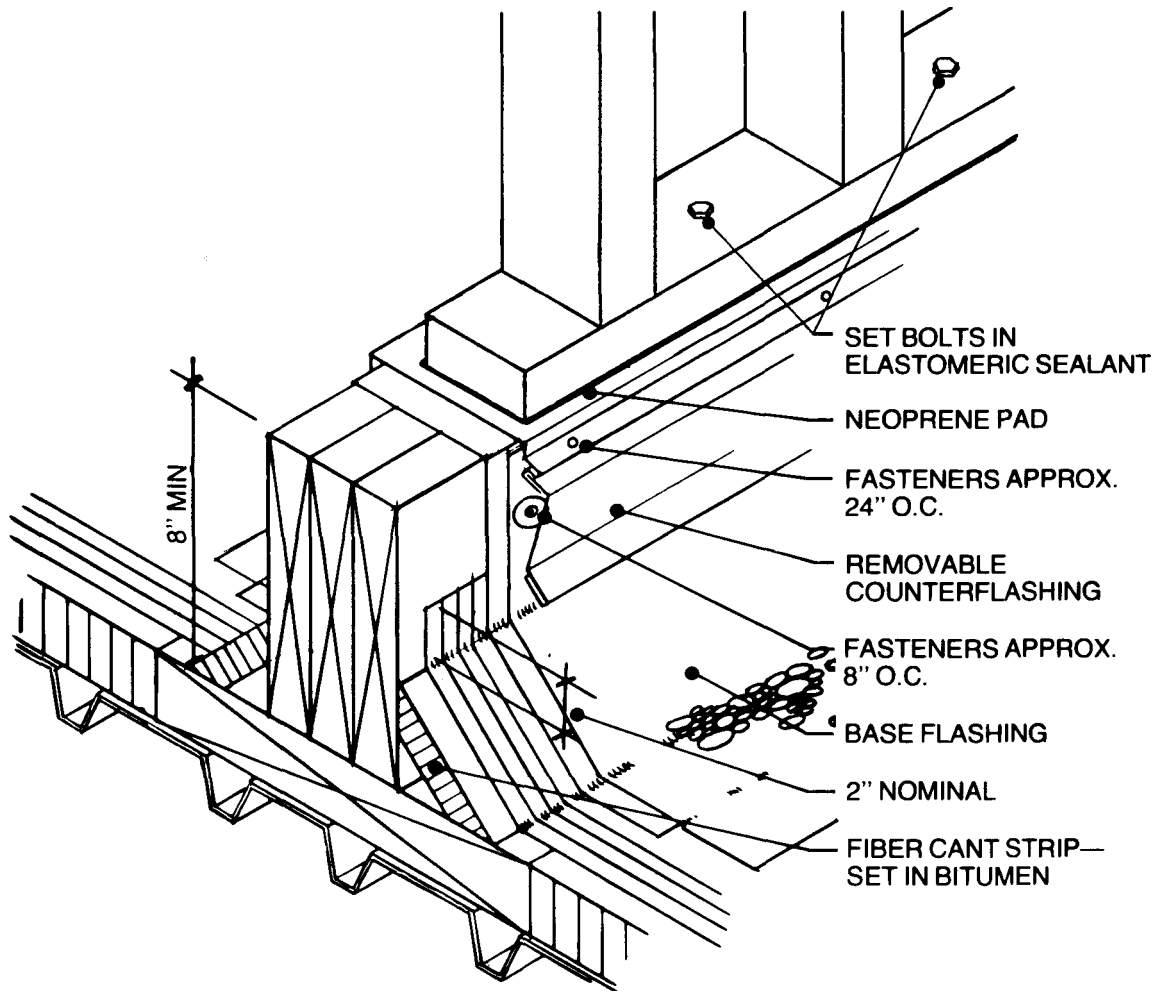

**NRCA NOTE:**

This detail allows for roof maintenance around the equipment or sign. The continuous support is preferred in light weight roof systems since the equipment weight can be spread over more supporting members. Where heavy structural systems are used or where the load can be concentrated over a column detail "N" (Figures 2.1, 2.2 & 2.3) is preferred. Clearance must be provided for removal and replacement of roofing and flashing between parallel supports.

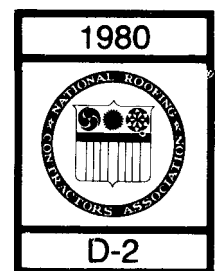

Modified by NBS

Figure 2.4 Installation of Wooden Supports for Collector Frame on a Solid Curb

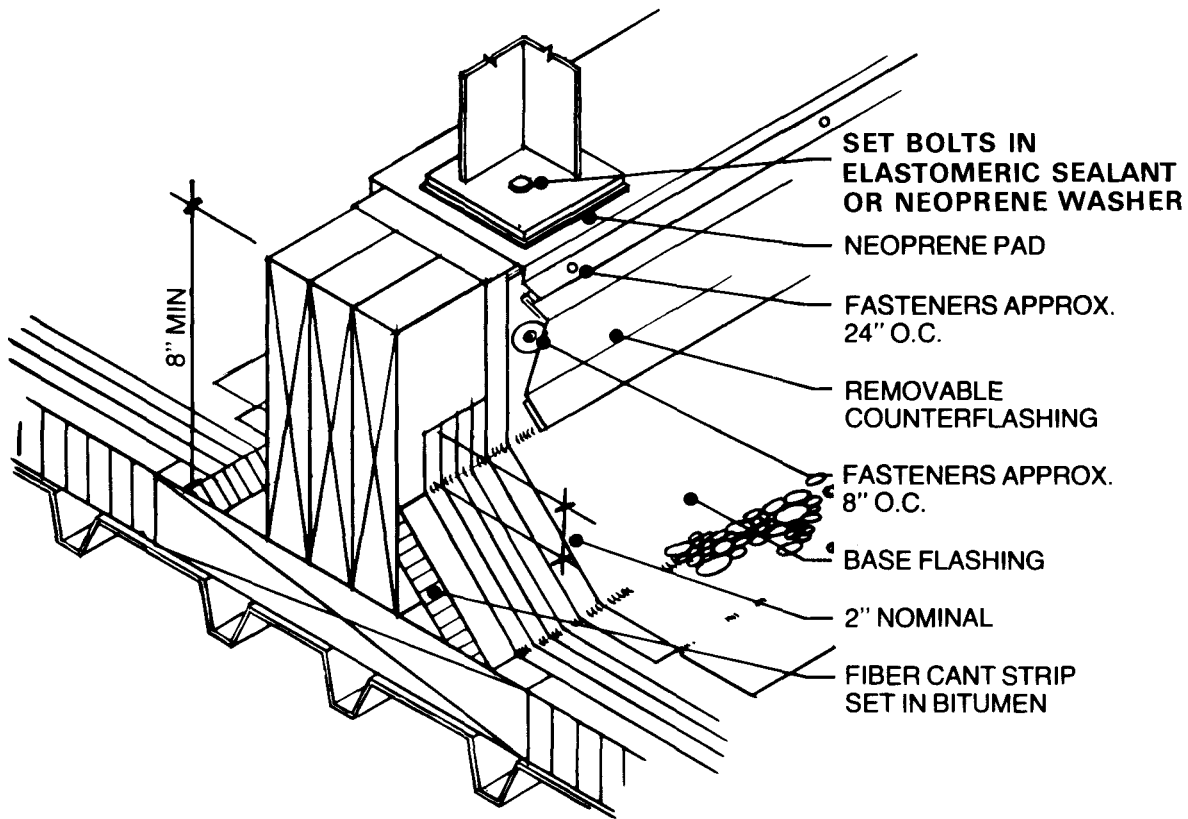

**NRCA NOTE:**

This detail allows for roof maintenance around the equipment sign. The continuous support is preferred in lightweight roof systems since the equipment weight can be spread over more supporting members. Where heavy structural systems are used or where the load can be concentrated over a column, detail "N" (Figures 2.1, 2.2 & 2.3) is preferred. Clearance must be provided for removal and replacement of roofing and flashing between parallel supports.

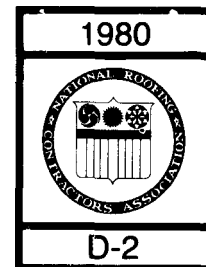

Modified by NBS

Figure 2.5. Installation of Steel Support for Collector Frame on a Solid Curb

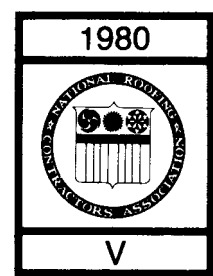
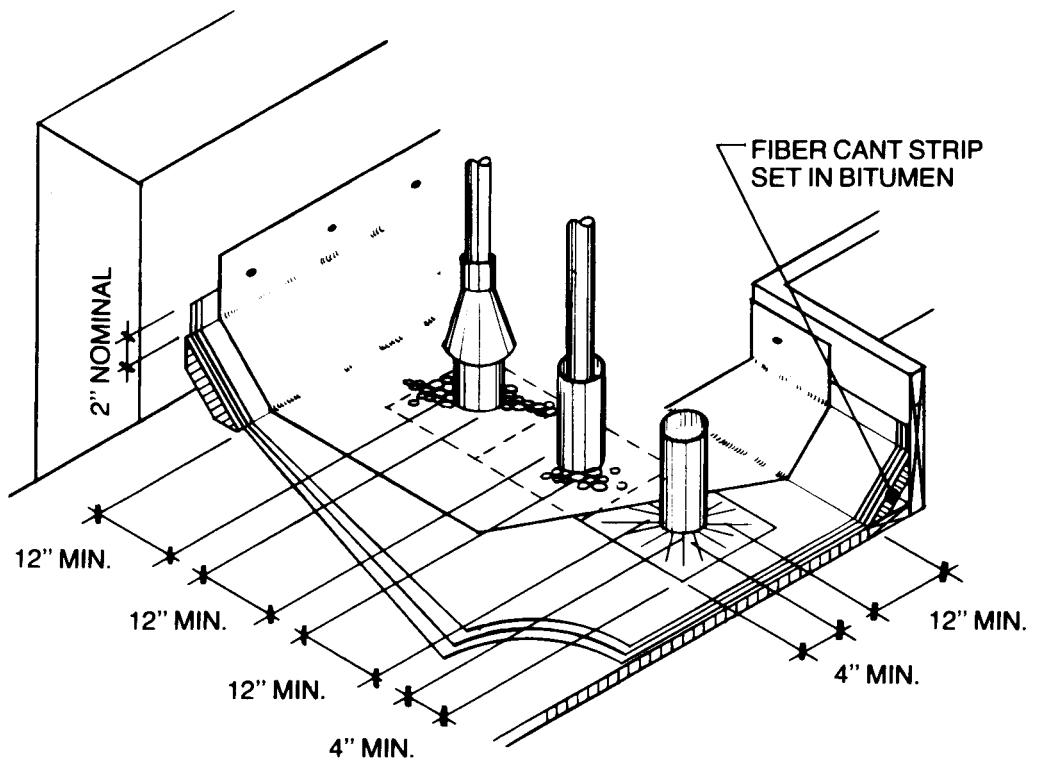
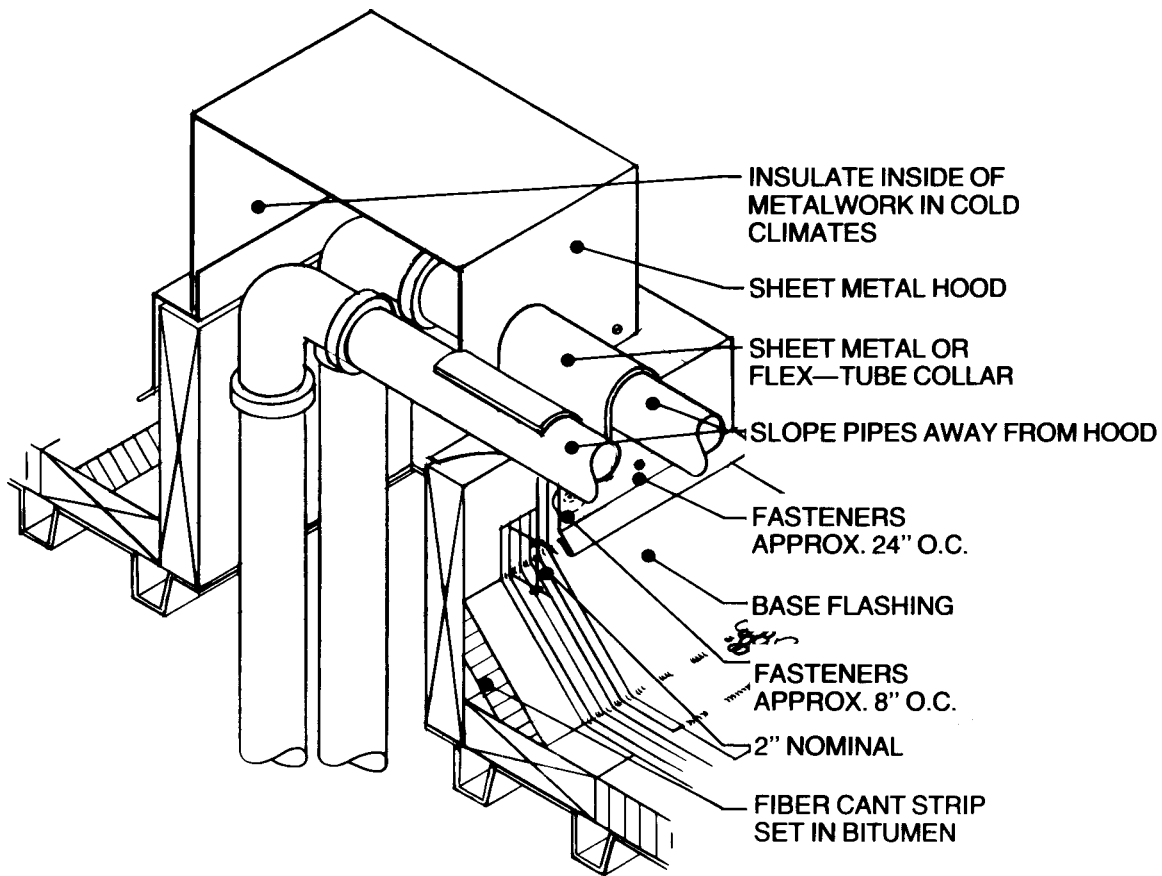

Figure 2.6 Recommended Clearances for Roof Penetrations from Walls, Curbs and Roof Edges



**NRCA NOTE:**

This detail illustrates another method of eliminating pitch pockets and a satisfactory method of grouping piping that must come up above the roof surface.

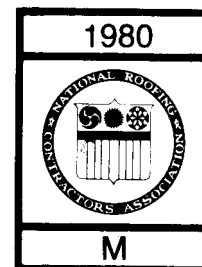
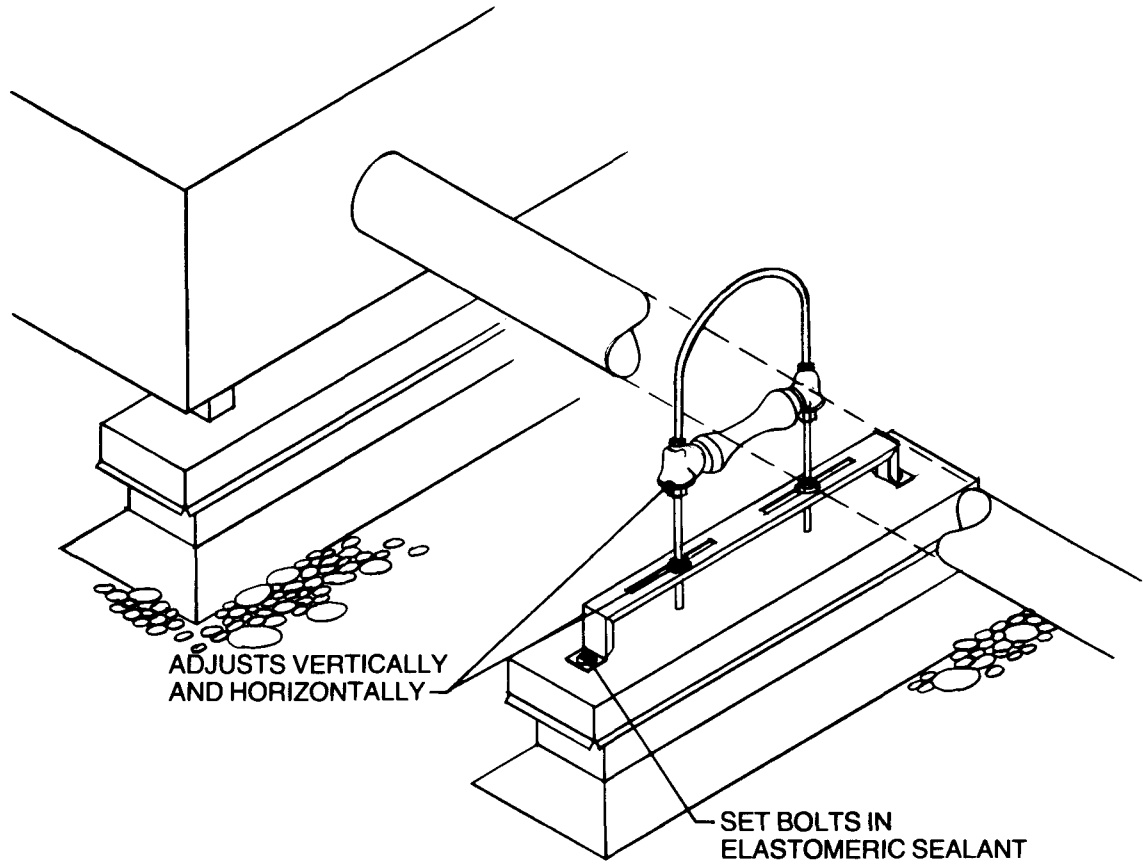

Figure 2.7 Detail of Housing for Pipe Penetrations Through Roof Deck



**NRCA NOTE:**

**This detail allows for expansion and contraction of pipes without roof damage. NRCA reaffirms its opposition to pipes and conduits being placed on roofs. However, where they are necessary, this type of pipe roller support is recommended.**

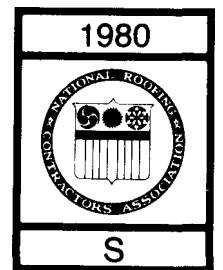

Figure 2.8. Pipe Roller Support

### 3. ACKNOWLEDGMENTS

This report was prepared under the sponsorship of the DoE Office of Solar Applications for Buildings and administrated by the Solar Technology Group at NBS.

The authors wish to acknowledge with thanks the many persons who contributed information included in this report. Special thanks are extended to building owners and their representatives for their assistance in providing access to their roofs and information regarding the installation of their solar collector system. The authors also thank Mr. Thomas H. Boone and Mr. Leopold F. Skoda of NBS for technical assistance in providing reports and other information. The cooperation of the NRCA for granting permission for the use of and in some cases modification of the NRCA construction details included in this report is acknowledged.

#### 4. REFERENCES

1. "Solar in Federal Building Demonstration Program," Proposed Rules and Notice of Public Hearing, Department of Energy, Federal Register, Vol. 44, No. 64, pp. 19328-19337 (April 2, 1979).
2. "Federal Demonstrations of Solar Heating and Cooling on Commercial Buildings Have Not Been Very Effective," Report to the Congress by the Comptroller General of the United States, U.S. General Accounting Office, EMD-80-41, 36 pages (April 15, 1980).
3. Van Wagoner, John D., Prospect Industries, Personal Communication.
4. "NRCA Construction Details," National Roofing Contractors Association, Oak Park, Illinois, (August 1980).
5. Mathey, Robert G., and Cullen, William C., "Preliminary Performance Criteria for Bituminous Membrane Roofing," National Bureau of Standards (U.S.), Building Science Series 55, 19 pages (November 1974).
6. Mathey, Robert G., and Rossiter, Walter J., Jr., "Properties of 21 Year Old Coal-Tar Pitch Roofing Membranes: A Comparison With the NBS Preliminary Performance Criteria," National Bureau of Standards (U.S.), NBSIR 77-1256, 25 pages (July 1977).
7. Busching, Herbert W., Mathey, Robert G., Rossiter, Walter J., Jr., and Cullen, William C., "Effects of Moisture in Built-Up Roofing - A State-of-the-Art Literature Survey," National Bureau of Standards (U.S.), Technical Note 965, 78 pages (July 1978).
8. "A Manual of Roofing Practice," National Roofing Contractors Association, Oak Park, Illinois, Third Revision, (1976).
9. "HUD Intermediate Minimum Property Standards Supplement," 1977 Edition, Solar Heating and Domestic Hot Water Systems, 4930.2, Vol. 5, U.S. Department of Housing and Urban Development, (1977).
10. "Wind Forces on Buildings and Other Structures," Loss Prevention Data 1-7, Factory Mutual Engineering Corporation, Norwood, Mass., 15 pages (June 1974).
11. "Insulated Steel Deck," Loss Prevention Data 1-28, Factory Mutual Engineering Corporation, Norwood, Mass., 12 pages (June 1980).
12. "Perimeter Flashing," Loss Prevention Data 1-49, Factory Mutual Engineering Corporation, Norwood, Mass., 16 pages (October 1979).
13. "Recommended Requirements to Code Officials for Solar Heating, Cooling and Hot Water Systems," DOE/CS/4281-1, U.S. Department of Energy, In Print.

14. "Active Solar Energy System Design Practice Manual," Preliminary Issue, U.S. Department of Energy, Solar/0802-79/01, 228 pages (October 1979).
15. Schwolsky, Rich, Williams, Jim, and Ross, Alan, "Solar Water Heating - Nuts and Bolts of Installation," Solar Age, Vol. 5, No. 3, pp. 41-50, (March 1980).
16. O'Rourke, Michael J., "Snow and Ice Accumulation Around Solar Collector Installations," National Bureau of Standards (U.S.), NBS GCR 79-180, 72 pages (October 1979).
17. "General Rules for Application of Solar Collectors Independently Mounted on Low-Sloped Roofs or on Sloped Roofs Covered with a Waterproofing Membrane," Cahiers du Centre Scientifique et Technique du Batiment, No. 204, Cahier 1613, 4 pages (November 1979).

## APPENDIX A. THE LITERATURE SURVEY

The purpose of the literature survey was to obtain background information in developing the guidelines and to determine whether any guidelines had been previously prepared. The primary sources reviewed during the survey were the engineering abstract services, the U.S. Department of Energy Data Base (EDB) information retrieval service, and the National Solar Heating and Cooling Information Center. Inquiries were made of roofing industry associations such as the National Roofing Contractors Association (NRCA) and the Asphalt Roofing Manufacturers Association (ARMA) to ascertain whether these organizations had prepared industry guidelines. Another source of information was the trade publications of the solar heating and cooling industry.

The literature contained many articles on the performance of solar systems. However, relatively few reports applicable to this study on installation guidelines were found. The results indicated that little information has been published regarding the effect of solar collector installation on the performance of low-sloped roofing systems. In addition, the results showed that guidelines for the proper installation of solar collectors on low-sloped roofs had not been developed in the United States. Several reports mentioned specific factors to be addressed during collector installation such as waterproofing of penetrations, roof drainage and clearance between the collectors and the roofing. The majority of the reports did not deal comprehensively with the installation of solar collectors on low-sloped roofs.

The French Centre Scientifique et Technique du Batiment (CSTB) has published general rules for use in France for the installation of solar collectors on low-sloped roofs for new construction [A1]\*. The report was concerned with the methods of attachment of the collectors to the roof, the waterproofing of the roof at the collector supports, and the waterproofing of penetrations for heat transfer fluid pipes. Sketches were given to illustrate the methods of collector support attachment, and waterproofing of the roof at collector supports and pipe penetrations. The CSTB general rules advised that the design of the solar installation be studied prior to installing the solar equipment. Subjects addressed during the design study included the effect of collector mass and climatic change on the stability of the attachment, walkways, the selection of the roof location for collector installation in so far as this effects worker safety during collector installation and maintenance, the proximity of collectors to penetrations, the clearance between the collectors and the roof, and the compatibility of collector heat transfer fluids with roofing bitumens.

Another report providing considerable background information for this study was the "Active Solar Energy System Design Practice Manual" issued by DoE [A2]. This manual presented selected architectural drawings taken from construction documents showing the physical characteristics of solar collector systems, methods of attachment of collector pipe supports, and roofing

---

\* Designations in brackets indicate reference in Appendix A which are listed in Section A.14.

penetrations for piping and collector supports for both liquid and air systems. The drawings were collected from the National Solar Heating and Cooling Commercial Demonstration Program. Although the report placed emphasis on presenting successful designs, some of the designs were considered by the reviewers preparing the manual to be good and others bad. Comments accompanying the drawings pointed out these good and bad features. It was noted in this report that many of the design features which could be a source of potential problems were identified and corrected before construction of the solar collector systems. Value judgments concerning design details were kept to a minimum in the manual and design recommendations were withheld to a large extent leaving the final choices to the designer [A2].

To summarize the results of the literature survey, the factors by which the installation of solar collectors may affect the performance of low-sloped roofing systems were compiled. These factors are the headings of the following sections of this Appendix. They are in alphabetical order and not listed in order of importance.

#### A.1 ATTACHMENT OF SOLAR COLLECTORS TO THE ROOF AND PENETRATIONS IN THE ROOFING

Attachment of solar collectors to the roof and penetrations in the roofing was found to be the most widely discussed literature topic concerning the effect of solar collector installation in the performance of low-sloped roofing systems [A1 - A11]. The common method of attachment uses upright collector supports or legs with horizontal plates fastened to the roof structure. The collector frame is secured to the upright supports. Dormer type supports may also be used to mount collectors on low-sloped roofs [A3]. In reporting on design factors for solar collectors, Weinstein stated that the attachment of the collector to the roof must be designed to support all loads imposed on it, including dead loads, horizontal thermal movement, and live, snow and wind loads [A4, A5].

Weinstein has described a number of methods for attaching collectors to the roof including penetrations through the membrane to the roof structure, sleepers mounted directly on the roofing and bolted to the roof structure, frames supported on parapet walls and dead load anchoring of frames with concrete blocks [A4, A5]. Sleeper installations were reported to have caused a high percentage of roof leak problems, since the sleepers may tend to shear the roofing. The DoE Design Practice Manual has presented many drawings which illustrate different methods of attachment of collectors and pipes to roofs [A2].

Attachments for collector supports and penetrations for piping are two critical areas in the roofing system which should be properly waterproofed during solar system installation [A3]. Waterproofing of collector supports and pipe penetrations has been accomplished by pitch pockets, neoprene rubber sleeves, and curb-mounted installations [A4 - A6]. Pitch pockets have been the most common of the three techniques [A4, A5]. However, because of poor performance and need for frequent inspections and maintenance, the National Roofing Contractors Association (NRCA) recommended against the use of pitch pockets for waterproofing of roofing penetrations [A7]. Some publications discussing solar collector

installation acknowledge the NRCA recommendation [A2, A8], but other publications do not mention it [A4, A6, A9]. It is interesting to note that the CSTB general installation rules for solar collector installation do not include a pitch pocket detail for waterproofing the penetrations created by collector supports and pipes [A1].

One reference has indicated that many recent solar installations use sealants for waterproofing of collector support attachments and piping penetrations [A3]. A caution was given therein that sealants should not be used where they must retain a significant volume of water from entering the building, since most sealants may not be reliable over the expected life of the roof.

Curbs and equipment stands are the NRCA preferred method for mounting equipment and waterproofing roof penetrations [A7]. Drawings are included in the NRCA construction details [A10]. Weinstein has reported that curbs should be adequately secured to the roof and possess sufficient lateral strength to resist movement of the collector frame due to wind loads or thermal expansion and contraction [A5]. Movement of curbs under these conditions could result in roof leaks. The use of concrete curbs for attaching and waterproofing solar collectors to roofs with concrete decks has been included in the CSTB general installation rules [A1].

Sleeves are used in collector installations. Their performance in assuring long-term watertightness of solar collector supports and pipes has received little discussion in the literature. As previously mentioned, some sleeves are neoprene rubber [A4, A5]. Schwolsky, Williams and Ross have questioned the use of rubber as well as plastics for solar installations, although they reported that these materials may be used for vent flashing and other system components [A3]. According to these authors, most available rubber and plastic materials are less reliable than most roofing systems. The use of rubber and plastic materials may require frequent roof repairs and result in higher long-term cost [A3]. The CSTB has recommended the use of sleeves for solar collector installations on roofs with structural decks of concrete and other materials [A1]. According to the CSTB, the top of the sleeve should be located at least 6 inches (150 mm) from the membrane surfacing, except in the mountain climates where it should be 8 inches (200 mm) above the surfacing.

Collector supports have been set on the top of the waterproofing membrane and anchored there through the use of concrete blocks [A4, A5]. A similar ballast method of attachment with specific limitations is included in the CSTB general installation rules [A1]. Other methods of attachment such as concrete curbs or direct attachment to the roof structure are described as being preferable to the ballast method [A1].

Collectors mounted on sleepers have been anchored to the roof using guy wires [A4, A5]. These publications did not indicate the method for waterproofing the roof penetrations for the guy wires.

## A.2 CLEARANCE BETWEEN COLLECTORS AND ROOFING

Adequate clearance between collectors and roofing is needed to allow for maintenance, repair and eventual replacement of the roofing [A4, A5]. Specific guidelines recommending the minimum distance constituting adequate clearance between the collectors and roofing were not found in publications applicable to the National Solar Heating and Cooling Commercial Demonstration Program. The CSTB has recommended minimum distances for clearance in its installation rules [A1]. These distances range from 8 inches (200 mm) to 32 inches (800 mm) depending on the type of installation, the size of the collectors and the slope of the roof.

## A.3 COMPATIBILITY OF COLLECTOR FLUIDS WITH THE ROOFING

Some collector fluids may not be compatible with roofing bitumens or other membrane materials. One reference has cautioned that roofs should be protected against damage resulting from possible spillage of high temperature fluids from collectors [A11]. Methods of protecting the roofing against heat transfer fluid spillage were not suggested. The CSTB general installation rules allow the use of incompatible heat transfer fluids provided that a catch basin having a drain connected to rainwater drains is placed under the collectors [A1]. In this case the heat transfer fluid must conform to health regulations [A1].

## A.4 DESIGN

The Project Experience Handbook developed in the National Solar Heating and Cooling Demonstration Program emphasized that the installation of solar collectors on flat roofs should be carefully considered in the design stage [A11]. It was stated that roof-mounted collectors may result in waterproofing problems that may be significant and should be addressed during design. The designers should account for all roofing penetrations, possible drainage problems created by collector mounts, and the ability to shed snow. It was pointed out that damage to the roofing during collector installation may necessitate reroofing. The Project Experience Handbook listed many design suggestions to avoid difficulties which had been observed in the National Solar Heating and Cooling Demonstration Program. Examples of these design suggestions included [A11]:

- ° provide detailed drawings and information on building envelope penetrations;
- ° provide detail of waterproofing treatment of collector support, roof mounts and roof penetration;
- ° since potential damage to roofing exists when retrofitting collectors, consider benefits of reroofing after collectors are installed;
- ° account for ice and snow buildup caused by collectors in estimating roof loading and allow for wind forces;

- design collector installations so as not to restrict water drainage from the roof; and
- detail mounting instruction to avoid misinterpretation by installer.

The design of the collector installation is also considered in the CSTB general installation rules [A1]. The rules require that an analysis be conducted before installation to assure satisfactory collector attachment to the roof. The mass of the collectors and their movement due to environmental effects are two significant factors to be addressed in the analysis.

Finally, as was previously mentioned, the U.S. Department of Energy has issued the preliminary version of the Design Practice Manual [A2]. The manual presented drawings and comments of selected design practices taken from construction documents in the National Solar Heating and Cooling Demonstration Program.

#### A.5 DRAINAGE OF THE ROOFING

Low-sloped roofing systems with adequate drainage will provide better long-term performance than those with ponded water on their surface. The installation of solar collectors should not adversely affect the drainage of a low-sloped roof [A1]. It has been reported that continuous curbs or sleepers used to mount solar collectors have blocked drainage and that the effect of collector installation on drainage should be considered during design [A4, A5].

#### A.6 FIRE SAFETY

Fire safety is a subject which has been treated primarily by model building codes and related documents (see Appendix B). One reference advised that some local codes may prohibit the installation of combustible materials on roofs [A2].

#### A.7 PROXIMITY OF PENETRATIONS TO COLLECTORS

NRCA recommends a minimum clear distance of 12 inches (300 mm) between roof penetrations and walls, curbs, roof edges and other penetrations [A10]. The CSTB general installation rules have recommended that the minimum distance of penetrations from collectors be 20 or 40 inches (0.5 or 1 m) based on the size of the collector [A1].

#### A.8 RETROFITTING EXISTING ROOFS

The condition of the existing roofing system at the time of solar system installation has received little attention in the literature. One reference has indicated that in retrofit applications a comparison should be made between the expected remaining service life of the roofing and the expected service life of the installed collectors [A3]. It was suggested that provisions should be made for simplified removal of the collectors for reroofing, if the existing roofing has an expected service life less than that of the collectors. The possibility of replacing the existing roofing at the time of solar installation was not addressed.

## A.9 ROOFING PRACTICE

Schwolsky, Williams and Ross have reported that good solar water heater installers are qualified with many skills including roofing ability [A3]. They indicated that if a solar installer lacks multiple skills, additional tradespeople are needed on the job to complete the installation. More importantly, they noted that lack of skill may cause faulty installation. It was advised that it is important to review established roofing practice for the type of roof upon which the collectors are being installed in order to understand fully the waterproofing concepts needed for the roofing system. Three publications on roofing practice are "A Manual of Roofing Practice" [A12], "Maintenance and Repair of Roofs" [A13], and "Manual of Built-Up Roof Systems" [A14].

## A.10 SAFETY OF WORKERS

The safety of workers should be considered during the design of solar collector installations, according to the CSTB [A1]. The location of the collector should be selected such that their installation and maintenance may be performed in a safe manner. One other reference [A11] has indicated that for overhead solar collector installations, personnel safety should be considered during design.

## A.11 SNOW

Snow accumulation on roofs is affected by solar collectors [A4, A5]. First, if the collectors are positioned low to the roof, they tend to act as snow fences. Raising the collectors and framework sufficiently above the roof surface may allow the wind to blow the snow from the roof. Secondly, if collectors extend over entries or walkways below the roof of the building, snow accumulated on the collectors may slide from the roof and present a hazard to pedestrians below. It has been suggested that an overhang under the collectors be used to protect pedestrians [A5].

O'Rourke recently conducted a study to measure snow and ice accumulation around solar collectors and to analyze the data to determine the effect of snow and ice on the structural performance of the collectors and their supports [A15]. He surveyed eight buildings with solar collectors on the roofs, four of which were low-sloped. His observations showed that solar collectors tend to act as a snow fence only if they are at an angle with respect to the roof surface, are oriented perpendicular to the wind direction, and are located close to the roof surface to shelter the snow on the roof from the wind. He noted that snow slides off the collectors shortly after the end of a snow storm, because of the relatively steep angle of the collectors and their relatively slippery surfaces. Quantitative design guidelines regarding collector installation and snow accumulation were not recommended because of the small number of buildings which were surveyed.

#### A.12 WALKWAYS

Roof surfaces which are subjected to heavy foot traffic should be protected with walkways or similar protective devices [A14]. Two reports indicated that protection of the roofing in the vicinity of the solar collectors should reduce the need to repair the roof [A4, A5]. The CSTB general installation rules indicated that walkways are needed with solar collectors [A1].

#### A.13 WIND

Wind effects on solar collectors have been addressed in the literature. Wind loads should be considered during the design of the solar system so that the attachment of the collectors to the roof will be adequate to support imposed wind loads [A4, A5, A11].

#### A.14 REFERENCES

- A1. "General Rules for Application of Solar Collectors Independently Mounted on Low-Sloped Roofs or on Sloped Roofs Covered with a Waterproofing Membrane." Cahiers du Centre Scientifique et Technique du Batiment, No. 204, Cahier 1613, 4 pages (November 1979).
- A2. "Active Solar Energy System Design Practice Manual," Preliminary Issue, U.S. Department of Energy, Solar/0802-79/01, 228 pages (October 1979).
- A3. Schwolsky, Rich, Williams, Jim, and Ross, Alan, "Solar Water Heating - Nuts and Bolts of Installation," Solar Age, Vol. 5, No. 3, pp. 41-50, (March 1980).
- A4. Weinstein, Stephen, "Architectural Concerns in Solar System Design and Installation," prepared for U.S. Department of Energy, Solar/0801-79/01, 27 pages (March 1979).
- A5. Weinstein, Stephen, "Architectural and Engineering Factors in Solar Systems Design," prepared for U.S. Department of Energy, Solar/0901-78/70, 22 pages (July 15, 1978).
- A6. Schwolsky, Rich, Williams, Jim, and Ross, Alan, "Weatherproofing Domestic Hot Water Systems - Nuts and Bolts of Installation," Part II, Solar Age, Vol. 5, No. 4, pp. 27-33 (April 1980).
- A7. Van Ryzin, Gary, National Roofing Contractors Association, Personal Communication.
- A8. "Installation Guidelines for Solar DHW Systems in One- and Two-Family Dwellings," prepared by Franklin Research Center for U.S. Department of Housing and Urban Development and U.S. Department of Energy, 111 pages (April 1979).

- A9. "Solar Water Heater Installation Guidelines," A Manual for Homeowners and Professionals, Commonwealth of Massachusetts, 44 pages (November 1978).
- A10. "NRCA Construction Details," National Roofing Contractors Association, Oak Park, Illinois, (August 1980).
- A11. National Solar Heating and Cooling Demonstration Program, Project Experience Handbook, Preliminary Draft, U.S. Department of Energy, DOE/CS-0045/D, 116 pages (September 1978).
- A12. "A Manual of Roofing Practice," National Roofing Contractors Association, Oak Park, Illinois, Third Revision, (1976).
- A13. "Maintenance and Repair of Roofs," Departments of the Army, the Navy, the Air Force and the Marine Corps, TM5-617 (Army), NAVFAC MO-113 (Navy), AFM 91-31 (Air Force), MCO P11014.9 (Marine Corps), Washington, D.C., 116 pages (January 1974).
- A14. Griffin, C.W., "Manual of Built-Up Roof Systems," The American Institute of Architects, McGraw-Hill, New York, 241 pages (1970).
- A15. O'Rourke, Michael J., "Snow and Ice Accumulation Around Solar Collector Installations," National Bureau of Standards (U.S.), NBS GCR 79-180, 72 pages (October 1979).

## APPENDIX C. THE FIELD SURVEY

A field survey of commercial and industrial buildings with low-sloped roofing systems having installed solar collector equipment was conducted during the study. The solar equipment was retrofitted to all roofs inspected and most of the solar systems had been installed for a period of two years or less. The purpose of the field survey was: to inspect the condition of the roofing with solar equipment; to identify roofing problems attributed to the installation of the solar equipment; to judge whether the installation of the solar equipment might adversely effect the roofing performance; and to determine whether the installation was performed in a manner consistent with acceptable roofing practice [C1-C3]\*. A number of factors by which the solar installation might affect the performance of low-sloped roofing systems were identified during the field survey. Observations from the survey provided useful background information in support of the guidelines.

Buildings with roof-mounted solar equipment selected for inspection in the field survey were located within approximately 200 miles (325 km) from the National Bureau of Standards. Most of the solar systems had been installed as part of the National Solar Heating and Cooling Commercial Demonstration Program. As many different types of commercial and industrial buildings as possible were included in the selection. Also different types of collector support frames and methods of attachment of the solar components to the roof system were considered in the selection of buildings.

### C.1 TYPES OF BUILDINGS, ROOFS AND SOLAR COLLECTOR SUPPORT FRAMES

Seventeen buildings included in the field survey were located at fifteen sites. Aggregate-surfaced built-up bituminous membranes provided the waterproofing on the roofs of sixteen of the buildings. One building had a smooth-surfaced built-up roof with an aluminum coating. Information from the survey indicated that minor roofing work accompanying solar system installation was often done by tradespersons other than roofing mechanics.

With one exception, the roofs surveyed had flat plate solar collectors. One roof had a concentrating solar collector system. The frames supporting the collectors consisted of steel or wood. For the majority of the buildings, the collector frames were attached to the roof system with steel supports (or legs) which extended through the roofing membranes. In these cases, the buildings had steel or concrete structural decks, except one which had a wooden deck.

In the case of five buildings, wooden frames supporting the collectors were attached to wooden planks (or sleepers) which were secured directly to the roof system by mechanical fasteners. Steel frames supporting collectors on another building were attached to the roof in a similar manner using sleepers.

---

\* Designations in brackets indicate references in Appendix C which are given in Section C.3.

The roof decks on five of these six buildings were wooden, and one had a deck consisting of precast concrete members.

For one solar installation, the collector frames were supported by heavy steel members having long spans which extended across the width of the building wing. These heavy steel members were supported by other heavy beams oriented along the length of the wall and supported by the exterior masonry walls and columns of the building. Limited penetrations in the roofing were made only at the edge of the building at the supports for the heavy steel members. No other penetrations had been made in the roofing, since heat transfer fluid pipes were run over the edge of the building to the storage tank on the ground below.

Another building had a large wooden deck constructed over a significant portion of the existing roofing system. Sprinklers were installed underneath this wooden deck. The deck supported the reflectors for the concentrator system. The deck was mounted on heavy steel members which spanned over long lengths of existing roofing. These heavy steel members were supported by exterior masonry walls or columns, and by a limited number of intermediate supports placed at interior walls or columns. With the exception of the locations for these supports, no penetrations were made into the roofing. Pipe penetrations were made into an equipment room attached to an exterior wall of the building. One other roof had no penetrations since the collector frame was supported by stub columns and heat transfer fluid pipes extended over the edge of the building.

## C.2 SURVEY RESULTS

Observations from the survey which pertain to the performance of low-sloped roofing retrofitted with solar components are discussed in this section of the report.

### C.2.1 Condition of Roofing

The condition of the surfaces of the bituminous built-up roofing systems at the time of the survey ranged in appearance from excellent to severely deteriorated. Cuts into the roofing to observe its conditions were not made during the survey. The deteriorated roofing on a wing of one building was about 20 years old and was experiencing many leaks. The solar collectors had been installed on this roof when the roofing was about 15 years old. It was reported that local roofing contractors had refused to reroof this wing of the building with the solar collectors and heavy steel frames in place.

Only one of the roofs observed during the survey had a membrane which was new at the time of the solar equipment installation. In this case, the building owner realized that the existing deteriorated membrane should be replaced before the roof was retrofitted with solar equipment. The flood coat and mineral surfacing were applied to this roof after the steel collector frames were in place. The ages of all the other roofs observed could not be ascertained. However, for about half of the roofs, their ages at the time of solar

equipment installation ranged from about 5 to 15 years old. Most of the roofing membranes appeared to be in good condition at the time of the survey. Roofing leaks or roof damage due to solar installation were reported for only three of the seventeen roofs inspected.

#### C.2.1.1 Protection of Roofing During Solar Collector Installation

Information was not generally available on whether or not roofing membranes were protected during installation of solar equipment. In a few cases, it was known that the roofs were not protected from foot traffic and equipment during solar system installation. However, some building maintenance personnel indicated that the solar equipment installers were aware of the need to avoid roofing damage during the installation. In one case, fiber boards were set on the existing membrane to protect it during the placement of the solar equipment.

One roofing membrane was damaged during the installation of the solar collectors and collector frames and about one year later this membrane was repaired. Leaks at pitch pockets around penetrations at supports for the collector frames were also fixed during the repair of the membrane.

#### C.2.2 Roof Slope

Only two of the seventeen roofs had adequate slope to drain water effectively. Most of the roofs were observed during the survey to have ponded water or ice under some areas of the solar collectors (Figure C.1). There were extensive areas on some of the roofs where ponded water near the collectors was over 2 inches (50 mm) in depth (Figure C.2). Some of the roofs which were dry at the time of the survey showed evidence of ponding water. On some of the roofs with ponded water under the collectors, mold, algae and plant growth were seen. In these areas, the roofing was in general exposed to little or no direct sunlight.

For one roof where a wooden platform had been constructed above the existing roofing, more than 2 inches (50 mm) of water was observed over some areas of the existing roofing (Figure C.3). Because of wood trusses and bracing under the platform, access to the built-up roofing was essentially impossible. Little natural light was available to the built-up roofing. There was a considerable amount of moss and a lesser amount of plant growth on the roofing.

#### C.2.3 Drains

In addition to having inadequate slope most of the roofs had drains which were generally not located to remove water from under the collectors and from locations of supports (legs) of the collector frames. In some cases drains were located near the edge of the roof while considerable ponding was evident over the central portions of the roof where the collectors were installed. A relatively large roof, about 80 x 100 feet (24 x 30 m), with little or no slope and almost completely covered by collectors, had only one drain which was located near a corner of the building. For many roofs, the installation of drains to remove ponded water from the vicinity of the solar equipment was warranted.

#### C.2.4 Attachment of Collector Supports and Roof Penetrations

The steel frames supporting collectors contained members that ranged from light weight piping to heavy structural beams. Some of the heavy structural beams had long spans while some of the lighter structural shapes or pipes had relatively short spans. Roof penetrations due to the installation of steel collector frames were mainly at the column supports attaching the steel frames to the structural members of the roof. The number of these penetrations varied according to the design of the solar installation. One roof was observed to have over 50 of these penetrations.

The wooden frames were in general fabricated from nominal 2 x 4 inch members. In some cases wood which was treated for rot resistance was used, however, due to weathering, this could not be determined in all cases. In addition, it was not determined if the wood had been treated with a fire retardant. Roof penetrations were made when sleepers supporting the wooden frames were attached to the roof using nails or lag bolts.

##### C.2.4.1 Steel Frames

Eleven solar installations had steel frames supporting the collectors. In eight of these cases steel columns that extended through the roofing supported the frames (Figure C.4). The steel columns were hollow members either circular, square or rectangular in cross section or structural rolled shapes. The roof penetrations at the support columns were waterproofed by means of pitch pockets except on one roof where pipe columns were flashed with nonmetallic sleeves. The sleeves extended about 10 inches (250 mm) above the roofing and at the top of the sleeve a caulking or sealant had been applied around the pipe.

Three types of supports other than steel columns penetrating the roofing were observed. These supports were attached to the structural frame of the building and included collector frames supported by either stub columns, the exterior walls and columns of the buildings, or by wooden planks or sleepers mechanically fastened to the roof. These types of supports are shown in Figures C.5, C.6 and C.7, respectively.

On one high rise building, heavy steel beams spanning the width of the roof formed the lower section of the frames supporting the solar collectors. These steel beams were generally supported over their span by pipe columns attached to the roof, except that the ends of the steel members were placed on the parapet walls of the building (Figure C.8). The height of these walls above the roofing apparently governed the minimum height of the collector frames above the roofing. Provisions were made at the parapet walls for the steel beams to move horizontally. Steel clips that extended over the flanges of the beams were welded to steel channels which were mechanically anchored with bolts to the top of the parapet walls. Figure C.9 shows the attachment of the steel beams at the parapet walls. It was not determined if the brick masonry wall was designed as a load bearing wall.

The base of one collector frame consisted of steel channels which were bolted to a 2 inch (50 mm) high curb. The type of curb could not be determined

since it was covered with bituminous base flashing. The method of attachment of the bolts to the curb also could not be determined.

The pitch pockets observed in the roof survey ranged in size from about 4 inches (100 mm) in diameter to 12 x 12 inches (300 x 300 mm) in size. Their height also varied from near the surface of the roofing to a few inches above the roofing. Some pitch pockets were filled with mopping grade asphalt while others were filled with plastic cement. On one roof the steel housings on some pitch pockets were tilted at a severe angle so that the housings were in contact with the support column, as shown in Figure C.10. Many of the pitch pockets were not completely filled with asphalt or there were openings between the asphalt and the column or between the asphalt and the metal housing of the pitch pocket. There were cases where the bitumen in the pitch pockets had embrittled and shrunk causing cracks and openings within the bitumen. It was also observed that in some cases pitch pockets had more than one pipe or other element within them.

In one case asphalt dripped from the pitch pockets into the building. These drips were reported as being very disruptive to the production work occurring within the building. Shields were installed in some areas under the roof to catch the dripping asphalt and prevent it from interfering with the production line in the building.

#### C.2.4.2 Wooden Frames

Wooden frames were supported by wooden planks or sleepers which were attached to the roof by nails or lag bolts (Figure C.11). The collector frames were either placed directly on the sleepers or mounted slightly above them using one or two nominal 2 inch thick boards between the sleepers and the collector frames. The sleepers were set on the roof so that they spanned a number of roof joists. The collector frames were either parallel or perpendicular to the sleepers depending on the orientation of the collectors with regard to the sun. For the collector frames which were parallel to the sleepers, the sleepers extended the entire length of the frame or there were about 1 foot (0.3 m) gaps every 8 to 10 feet (2.4 to 3.0 m) of sleeper length. The sleepers oriented perpendicular to the collector support frames were spaced about 6 feet (1.8 m) apart and extended 2 to 3 feet (0.6 to 0.9 m) in front and in back of the collector frames.

In most cases the top of the sleepers were about 1 inch (25 mm) above the surface of the built-up roofing. In some cases the sleepers were not covered and in others the sleepers were covered with copper sheet or coated roofing felts. There were many instances where ponded water was observed to be above the bottom of the sleepers (Figure C.12).

For some roofs the mass supported by the sleepers caused them to settle into the roofing. Figure C.13 shows a sleeper which had sunk into the flood coat and aggregate surfacing of the roofing. It was not ascertained whether the membrane had been damaged, although the roof was not reported to be leaking in that location.

### C.2.4.3 Pipe Penetrations

Penetrations for heat transfer fluid pipes were observed on many of the roofs. The method of flashing between the roofing and pipes was not always discernible because of the presence of the pipe insulation and its protective covering (Figures C.14 and C.15). Some pipe insulations and protective coverings were observed to be in poor condition. For some roofs surveyed excessive quantities of asphalt or plastic cement were observed at pipe penetrations (Figure C.15). It could not be determined whether the excessive quantities of asphalt were applied as the original waterproofing of the pipe penetrations or as subsequent repairs of roof leaks at these locations.

For some roofs, pipe penetrations were waterproofed with pitch pockets, as shown in Figure C.16. Many of the pitch pockets for pipe penetrations were not completely filled with asphalt. None of the roofs had pipe penetrations waterproofed with metallic sleeves or housings.

### C.2.5 Clearance

#### C.2.5.1 Clearance Between Collectors and Roofing

The clearance between the solar collectors and/or the steel frames supporting them and the surface of the roofing varied considerably. In some cases clearance was a few inches and in others it was observed to be as much as 24 inches (600 mm). In many cases, the observed clearance was considered inadequate to allow proper repair, maintenance and replacement of the roofing. Figure C.17 gives an example of inadequate clearance between steel collector frames and the roofing.

For the wooden frames supporting collectors there was little clearance at the front of the collector frame, about 4 inches (100 mm) or less, since they were generally supported by blocks of wood or planks attached to a sleeper. In many of these cases, clearance was also inadequate under the collectors, as shown in Figure C.18.

#### C.2.5.2 Clearance Between Piping and Roofing

In many cases piping had been installed with adequate clearance above the roof surface. Nevertheless, many other cases were observed where 6 inches (150 mm) or less clearance was available between the roofing and the piping (Figure C.19). In extreme cases, piping was resting directly on roof surfaces. In another case, many areas of base flashing were not accessible because of pipes and pipe supports projecting from collector frames.

#### C.2.5.3 Clearance Around Collectors

Clearance around collectors was sometimes inadequate for maintenance and repair of both collectors and roofing. Figure C.20 shows an installation where little clearance was present between the front of an array of collectors and a Mansard style roof projection. In some cases, the installation of the frames supporting the solar collectors interfered with existing roofing penetrations.

Modifications to a vent pipe and to a curb supporting a ventilator are shown in Figures C.21 and C.22, respectively.

Some roofing penetrations made during the installation of the solar equipment were too close to existing flashing. Examples of this observation are given in Figures C.23 and C.24. In both figures, the solar penetrations are too close to the flashing at the edge of the roof.

#### C.2.6 Supports for Pipes

Pipes carrying heat transfer fluids were supported by the collector frames or by pipe supports set on the roof. Some of these pipes extended for considerable distances along the roof. When attached to the collector frames, pipes were generally supported by hangers and brackets. In one case roller supports hung from the collector frames were used to support the pipes (Figure C.25).

Pipes extending over the roof away from the collector frames were placed on roller supports or improvised types of supports. Common improvised supports were blocks of wood approximately 2 x 4 x 12 inches (50 x 100 x 300 mm) or metal plates with an attached metal stem which extended up to the pipe. The blocks of wood or metal plates rested directly on the roofing membrane (Figure C.26). Some pipe supports had a 2 x 6 x 12 inch (50 x 150 x 300 mm) block of wood with a 1 inch (25 mm) diameter steel pipe upon which the heat transfer fluid pipe was placed.

#### C.2.7 Safety

##### C.2.7.1 Access to the Roof

Access to the roofs of most one or two story buildings was by a portable ladder. It was observed that some of these portable ladders were under-sized and their use posed a safety hazard. In the higher buildings the roof area could be entered through a penthouse or access door. The roofs of some buildings one and two stories high had permanent access through outside stairways. In general, the buildings with permanent access to the roof were larger than those for which portable ladders were needed for roof access. One of the permanent stairways, installed specifically to access the collectors, was mounted such that it could be lowered or raised. When needed, it was lowered to the ground. When not in use, the stairway was raised high off the ground and locked in that position to prevent unauthorized persons access to the roof. Another building had a high metal fence and gate around the permanent stairway. The gate was kept locked when the stairway was not in use.

Three of the buildings had a hatch for entrance to the roofs. These roof hatches were standard types commonly found on industrial and commercial buildings. In conjunction with the solar system installation on one building, a roof hatch was installed. In this case, two wooden roof joists were cut and sections of the joists were removed to provide space for the hatch. After installing the hatch, the cut ends of the roof joists were left free and were not supported or braced.

### C.2.7.2 Access on the Roof

In many cases access on the roof was severely restricted because of the solar collectors, collector frames and piping. Some of the steel collector frames extended over long spans and contained large beams and many lateral braces which seriously hindered roof access. It was necessary to climb over or crawl under these beams and braces in order to have access to the entire roof.

The beams and braces were relatively closely spaced and their top surfaces were as much as 3 feet (0.9 m) above the surface of the roofing. In addition, in some cases the collector frames extended beyond the edge of the roof making it impossible to walk around the entire perimeter of the collector array. Figure C.27 is an example of an array of collectors installed close to the edge of the roof. It is questionable whether the roofing and flashing in some areas under these collectors could be safely accessed for repair and maintenance without a ladder or other means to reach these roof sections from the ground.

Some of the steel collector frames had many vertical and sloped members and braces in addition to horizontal braces located about 4 or 5 feet (1.2 or 1.5 m) above the roofing. This made it very difficult to move from one place on the roof to another when both low and high braces were encountered at the same time.

Access on the roofs was not limited for all the buildings surveyed. Some solar installations had little effect on roof access and it was possible to move freely around the perimeters of the collector arrays, as shown in Figure C.28. In these cases, the total roof area was more than sufficient to mount the number of collectors required by the design of the particular solar system.

### C.2.7.3 Unsafe Conditions

Some unsafe conditions were observed other than those concerning access to the roof and access on it. In one case the integrity of a fire wall had been violated. Pipes were installed through holes that had been knocked out of an existing concrete masonry fire wall, as shown in Figure C.29. In another case narrow, steep and unstable ramps considered unsafe for use were installed over collector frames (Figure C.30). The ends of the ramps were supported on the roof surface by nominal 2 x 4 inch blocks.

### C.2.8 Walkways

Walkways were observed on some areas of some roofs, while many roofs had no walkways. The observed walkways consisted of different types of materials including asphaltic plank, coated felts, hollow aluminum sections and wooden frames. Some of these types of walkways over the roofing are shown in Figures C.31 and C.32. Some hollow aluminum sections of walkway were supported on the roof surface by nominal 4 x 4 inch wooden boards about 15 feet (4.6 m) apart. The coated felt walkways appeared to be ineffective.

Walkways were also observed over pipes. Some of the walkways were structurally adequate and not only made it easier for people to walk over pipes but helped protect the pipes from foot traffic. An example is given in Figure C.33.

#### C.2.9 Debris on Roof

Debris was observed on many roofs. The debris included pieces of pipe, wood, insulation, wire and other materials left over from the solar equipment installation. Figure C.34 shows debris on the roof which should have been removed. Other objects such as pails containing asphalt plastic cement had been left on roofs when repairs of roof leaks were made.

#### C.2.10 Maintenance

From conversations with individuals familiar with the history of the roofs, it was found in general that the roofs were not inspected as part of a scheduled maintenance program. Maintenance of the roofing was performed only when leaks were reported. Roofing repairs were usually done by individuals other than roofing contractors.

Few repairs had reportedly been made on the roofs after solar equipment installation. As previously noted, most of the solar collector systems had been installed for two years or less at the time of the field survey.

#### C.2.11 Design of Solar System Installation

It was observed that many of the solar installations could have improvement in the overall design with regard to the roofing system. Some of the problems described in this Appendix may have been avoided with improved design. For example, in some cases frames supporting collectors interfered with existing roof penetrations, as noted in Section C.2.5.3. In other cases supports for collector frames and heat transfer fluid pipes penetrated the roofing too close to the edge of the roof or to other components such as drains, walls and pipes. In many cases, improved design would have resulted in easier and safer access on the roof. In others, the roof could not accommodate the needed number of collectors in a manner to provide easy and safe access on the roof because of penetrations, installed equipment and inadequate space.

Another example of inadequate design was the location of collector arrays in roof areas which had 2 inches (50 mm) of ponded water or more. The water completely obstructed access for roofing maintenance work around the collectors. In some cases this may have been avoided by the addition of drains or by selecting another area of the roof for location of the collectors.

### C.3 REFERENCES

- C1. "A Manual of Roofing Practice," National Roofing Contractors Association, Oak Park, Illinois, Third Revision, (1976).

- C2. "Maintenance and Repair of Roofs," Departments of the Army, the Navy, the Air Force and the Marine Corps, TM5-617 (Army), NAVFAC MO-113 (Navy), AFM 91-31 (Air Force), MCO P11014.9 (Marine Corps), Washington, D.C., 116 pages (January 1974).
- C3. Griffin, C.W., "Manual of Built-Up Roof Systems," The American Institute of Architects, McGraw-Hill, New York, 241 pages (1970).

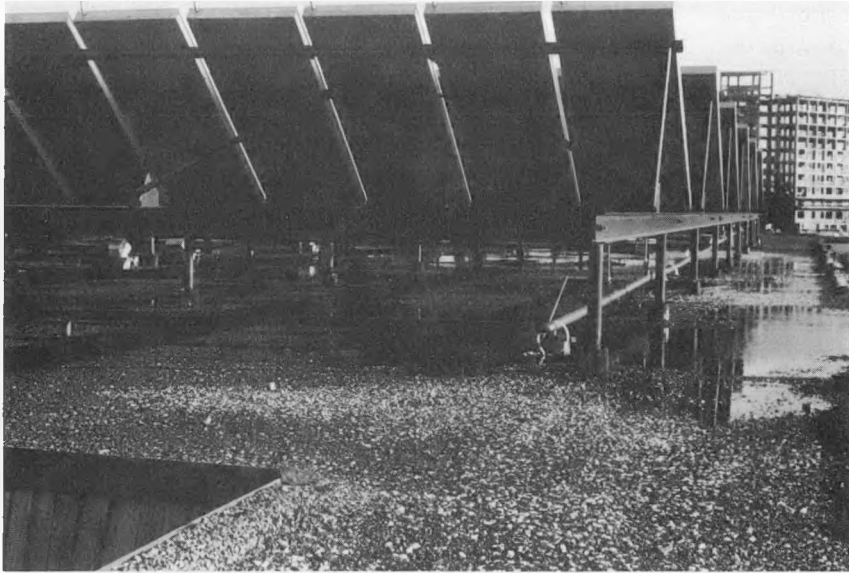

Figure C.1 Ponded Water Under Solar Collectors

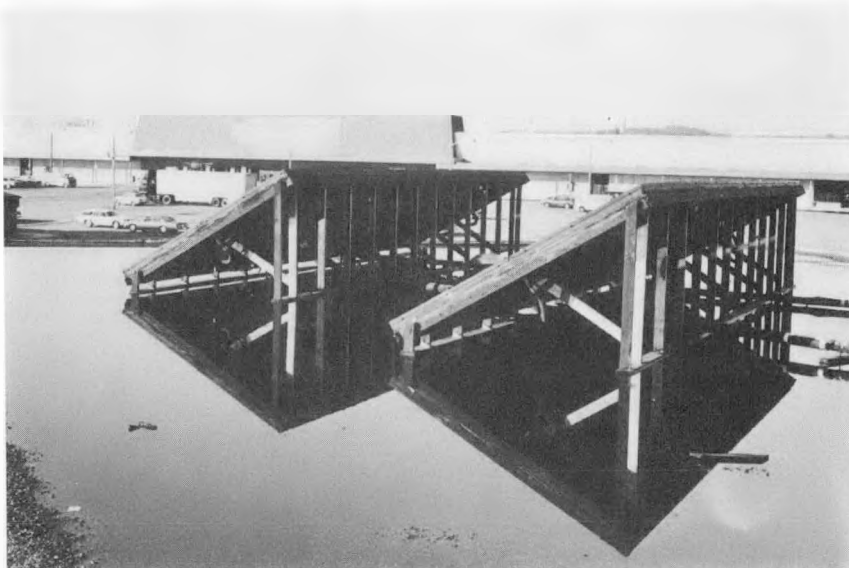

Figure C.2 Ponded Water Over 2 inches (50 mm) Deep Around Collectors



Figure C.3 Ponded Water on Roof Surface Extending Under Large Wooden Platform Supporting Solar Reflectors



Figure C.4 Steel Columns Extending Through Roofing Support Collector Frames

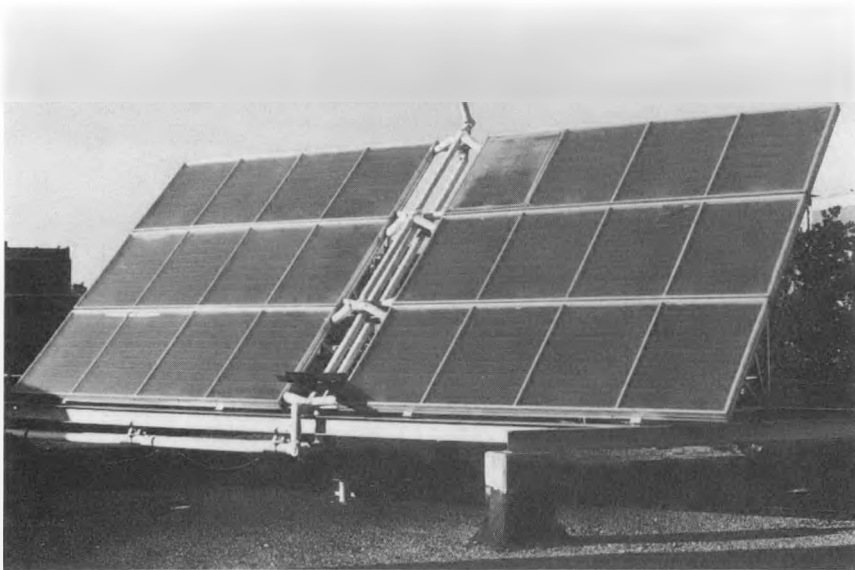

Figure C.5 Collector Frames Supported by Stub Columns



Figure C.6 Large Wooden Reflector Frame Supported by Exterior Walls and Columns of the Building



Figure C.7 Collector Frame Supported by Wooden Sleeper Mechanically Fastened to the Roof

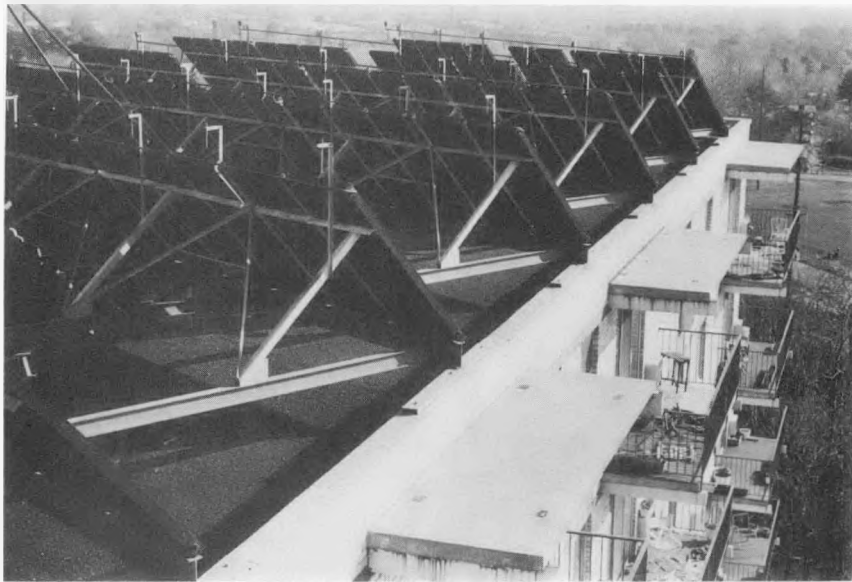

Figure C.8 Collector Frames with Ends of Steel Beams Supported by Parapet Walls



Figure C.9 Attachment of Collector Support Beam Using a Steel Clip Welded to a Channel which is Bolted to a Parapet Wall



Figure C.10 Collector Support Column in a Tilted Pitch Pocket

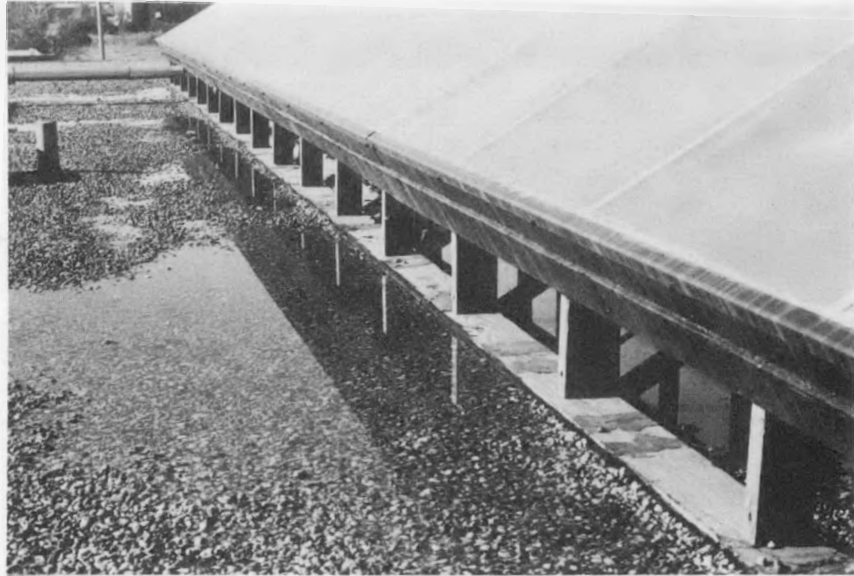

Figure C.11 Wooden Sleeper Mechanically Attached to Roof



Figure C.12 Ponded Water Above the Bottom Surface of the Wooden Sleepers

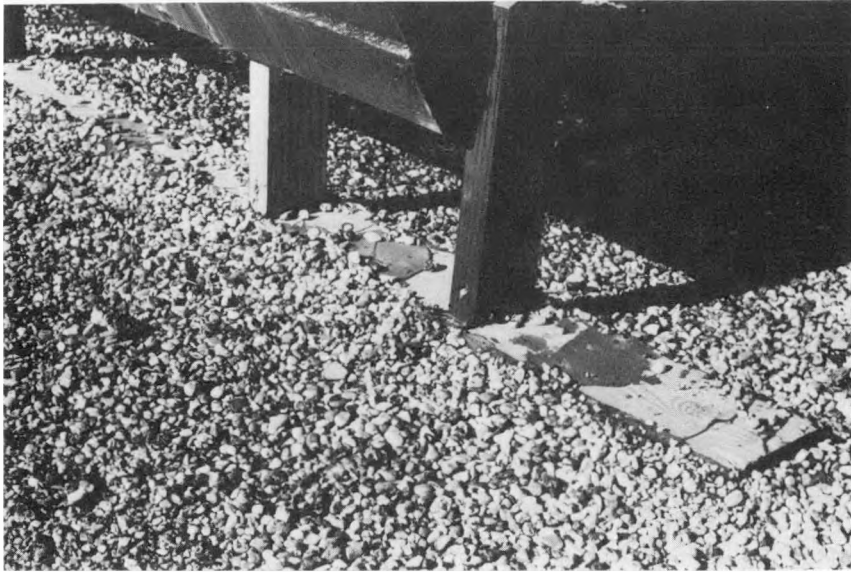

Figure C.13 Sleeper Which Had Sunk into Asphalt Flood Coat and Aggregate Surfacing



Figure C.14 Pipe Penetration for Which The Type of Flashing was Not Determined

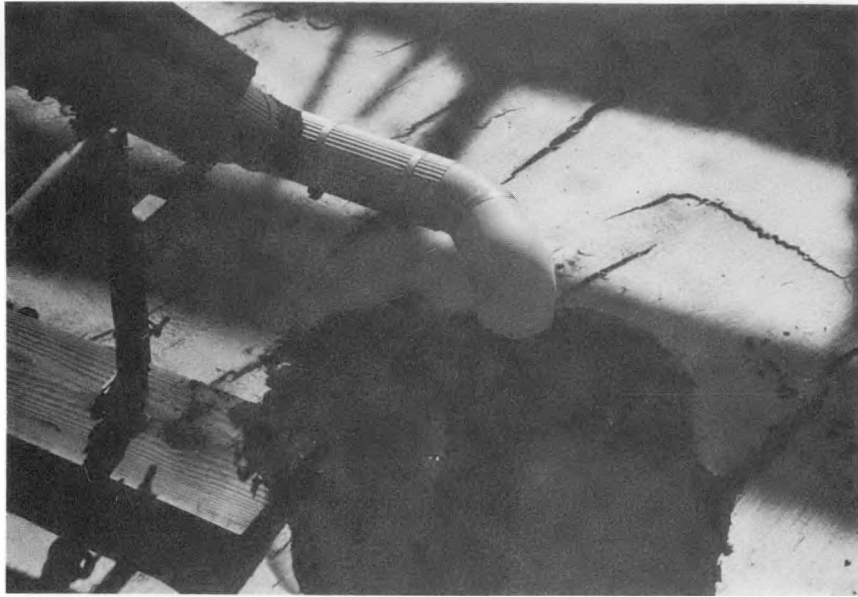

Figure C.15 Excessive Quantity of Asphalt Around Pipe Penetration With Undetermined Type of Flashing



Figure C.16 Pitch Pockets for Pipe Penetrations



Figure C.17 Inadequate Clearance Between Steel Collector Frames and Roofing



Figure C.18 Inadequate Clearance Between Wooden Collector Frames and Roofing



Figure C.19 Piping Located Close to Roof Surface



Figure C.20 Inadequate Clearance Between Front of Collector Array and a Mansard Style Roof Projection



Figure C.21 Vent Pipe Modified to Allow for Solar Collector Installation

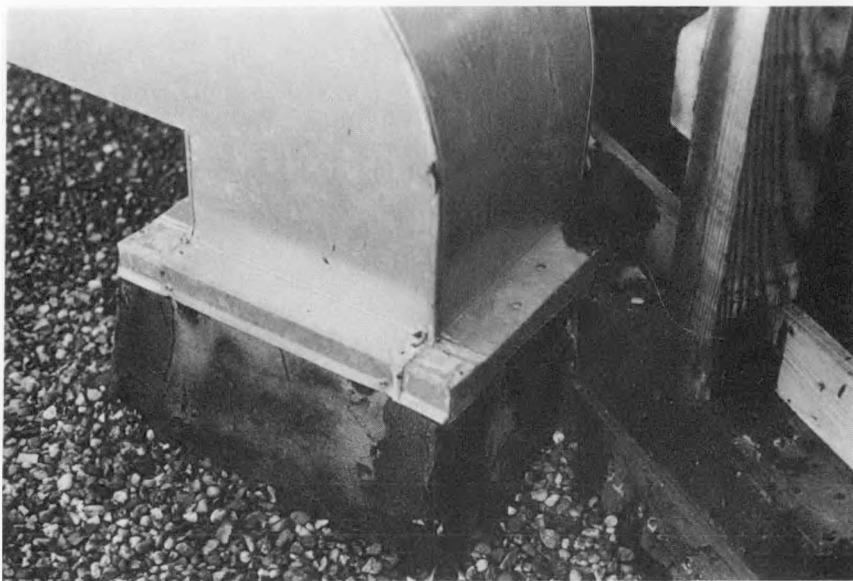

Figure 22. Modification of a Curb Supporting a Ventilator

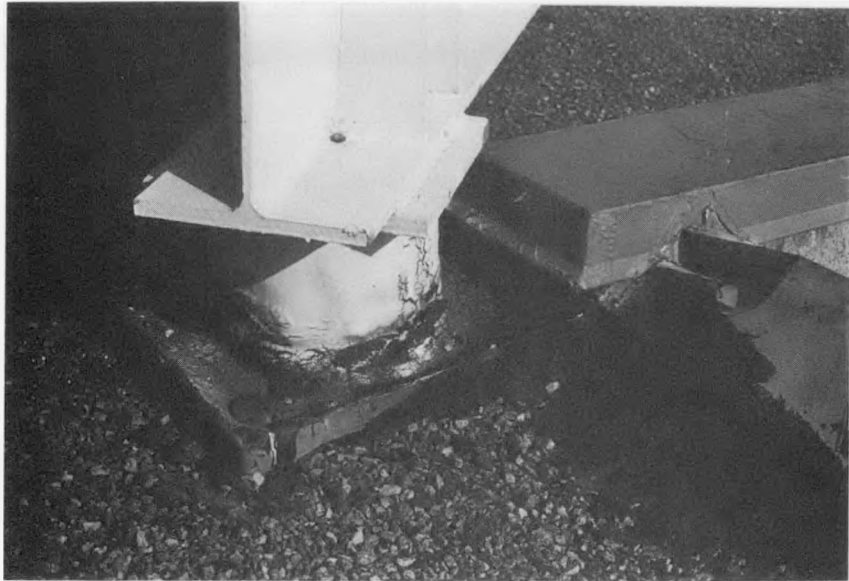

Figure C.23 Penetration of Collector Support Column  
at the Edge of the Roof



Figure C.24 Solar Penetration Adjacent to the Edge  
of the Roof

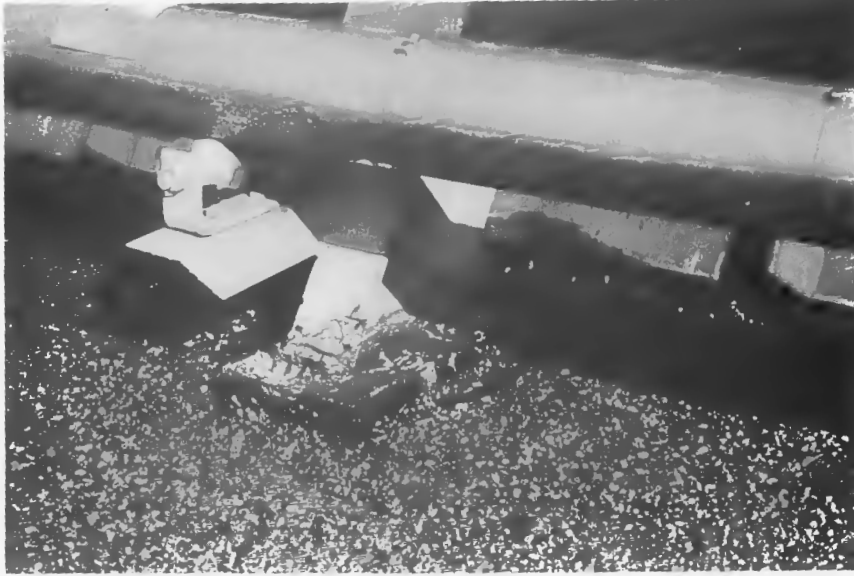

Figure C.25 Pipe Roller Support Attached to Collector Frame

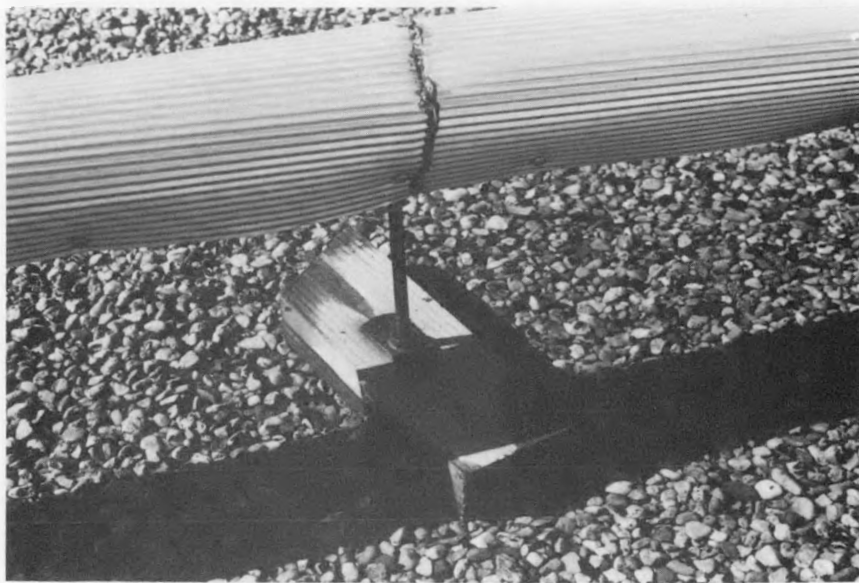

Figure C.26 Pipe Support Bearing on Roofing Surface



Figure C.27 Collector Array Installed Near Roof Edge

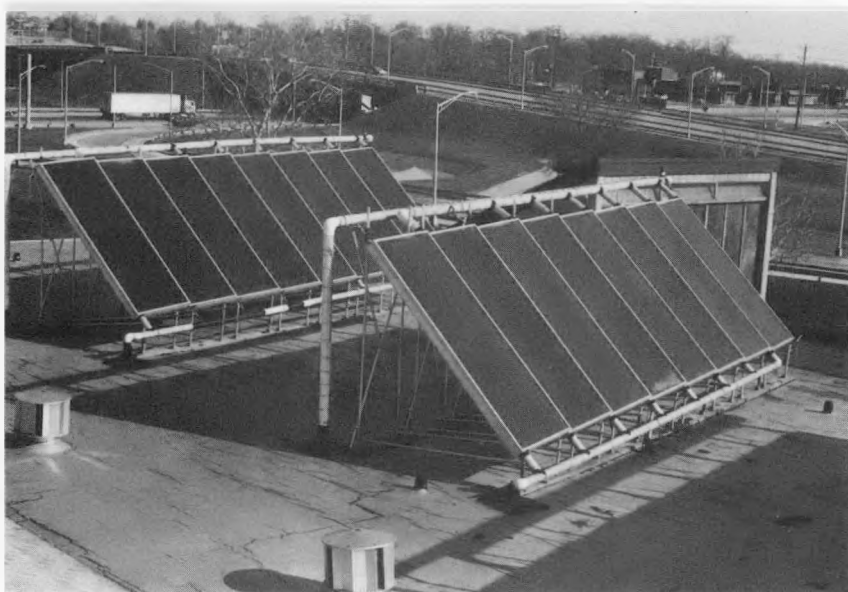

Figure C.28 Installation Having Adequate Access Around Collector Arrays



Figure C.29 Fire Wall Penetrated by Solar Piping

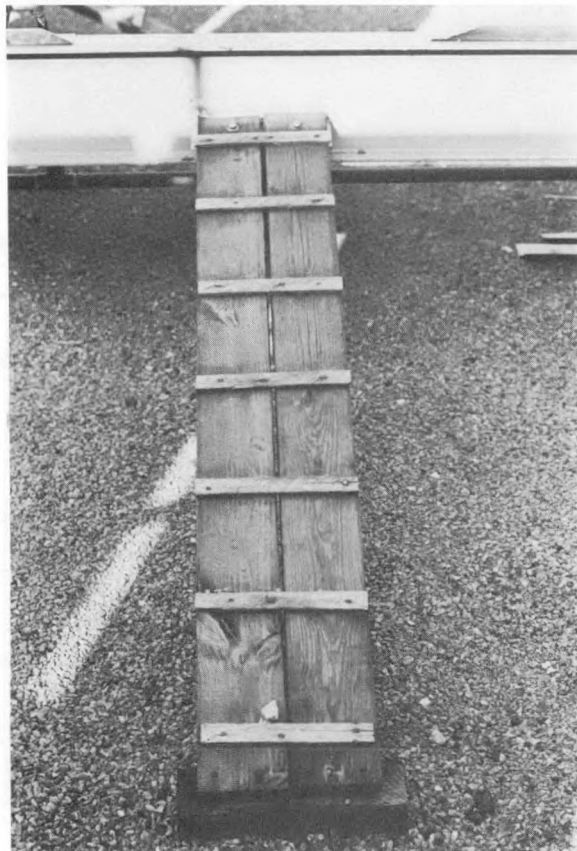

Figure C.30 Narrow and Steep Ramp for Passage Over Steel Beam of Collector Frame



Figure C.31 Coated Felt Walkway on Roofing

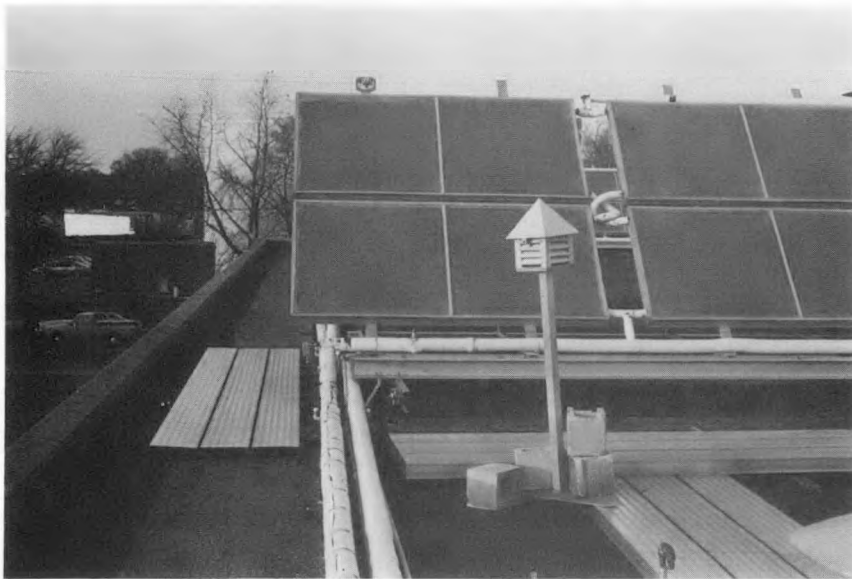

Figure C.32 Hollow Aluminum Sections Used as Walkways

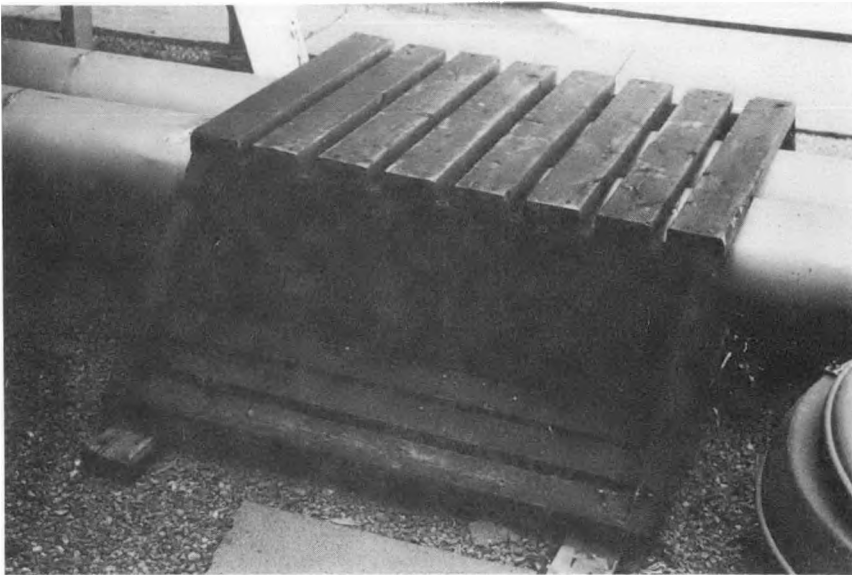

Figure C.33 Walkway Over Piping



Figure C.34 Debris On Roof from Solar Installation

## APPENDIX B. MODEL BUILDING CODES AND RELATED DOCUMENTS

Model building codes and related documents such as the Intermediate Minimum Property Standards Supplement of the U.S. Department of Housing and Urban Development (HUD) were examined to obtain information concerning the effect of the installation of solar components on rooftop safety. The installation should not pose an undue risk to the safety of building occupants and of individuals who require access to the roof, solar collector components and other roof-mounted equipment. In addition, the installation of solar components should not increase the risk of fire and wind damage to the roof.

The U.S. model building codes examined in the study were the Basic Building Code, the Uniform Building Code, and the Standard Building Code\*. The model building codes contain provisions applicable to the installation of equipment on roofs but not specifically for solar components.

The Council of American Building Officials (CABO) has prepared a model document for code officials that contains recommended requirements for solar heating, cooling and hot water systems [B1]\*\*. The purpose of the recommended requirements is to provide for reasonable protection of the public health and safety, while encouraging utilization of solar energy technologies. The CABO recommended requirements provide new provisions for consideration for incorporation into existing codes.

The CABO recommended requirements [B1] contain provisions applicable to the installation of solar components on low-sloped roofs. These provisions include the protection of water penetration into the building, protection of pedestrians from sliding snow and ice, structural requirements, and fire safety requirements. With regard to water penetration, protection around openings and extensions of solar components through roofs, floors and walls should be in accordance with the applicable provisions given in the Basic, Standard and Uniform Building Codes. These provisions of the model codes deal in general with the flashing of vertical surfaces and penetrations. The requirement concerning sliding snow or ice is that provisions should be made over pedestrian and vehicular ways to protect those areas from sliding snow and ice.

The provision in the CABO recommended requirements [B1] concerning the structural requirements states that the collector and supporting structure, including building components, shall be designed and constructed to support various types of loads. These loads are: dead load of collector, components and transfer liquids; live, snow, wind and seismic loads; expansion and contraction loads resulting from temperature changes; and a combination of these loads. The fire safety requirement is that collectors located above or upon a roof shall not reduce the required fire resistance classification of the roof

---

\* Organizations responsible for these model codes and their addresses are given in Section B.2

\*\* Designations in brackets indicate references in Appendix B which are given in Section B.1.

covering materials. Two exceptions to the fire safety requirement are given. One exception is for one and two family dwellings. The other is for collectors located on buildings not over three stories in height and/or 9,000 square feet (836 m<sup>2</sup>) total floor area provided that the collector installation complies with specific requirements concerning combustibility, materials and size of roof area occupied by collectors.

The HUD Intermediate Minimum Property Standards (MPS) Supplement for Solar Heating and Domestic Hot Water Systems contains sections dealing with the effect of solar collector installation on the performance of low-sloped roofs [B2]. These sections include provisions for watertightness of roofing penetrations, fire safety, clearance of collectors above the roof surface, snow, wind loads and fungus growth. The provision for the watertightness of penetrations requires that flashings be designed to prevent the penetration of water or melting snow for the life of the roof system and to permit minor repair without disturbing the roof membrane, collector supports or collector panels.

Three provisions concerning roofing fire safety are included in the MPS Supplement. One provision states that the design and installation of solar systems should not impair the natural movement of occupants of the building or emergency personnel. In this regard, a commentary states that special consideration should be given to the effect of the configuration of roof-mounted collectors on fire-exiting, fire-fighting or emergency rescue. The location of solar equipment on the roof should not reduce its usability for access or egress. The second fire safety provision requires that the solar collector system or components shall not reduce the fire retardant characteristics of the roof covering below the level specified in the Minimum Property Standards. The third fire safety provision requires that penetrations through fire-rated assemblies should not reduce the fire-resistance ratings required by the Minimum Property Standards.

The snow and wind provisions in the MPS Supplement are concerned with the loads which are imposed on the roof structure because of the presence of the collectors [B2]. In addition, a requirement provides that protection be furnished over entrances and locations of pedestrian and vehicular ways to restrain or deflect sliding snow and ice masses which may slide off elevated solar system components.

With regard to clearance between the solar collectors and roofing membrane, the MPS Supplement states that consideration should be given to potential problems in reroofing under collectors. It is noted that no recommendations were made for the minimum height of the collectors above the membrane for adequate clearance. It is mentioned that there is the potential for mildew or other types of fungus growth under collectors, since the shaded membrane area under collectors may support fungus growth in some warm, moist climates. The MPS Supplement indicates that special considerations should be included in the design of the installation to avoid fungus growth problems in areas where it is likely to occur. Specific advice concerning the design considerations for avoiding fungus growth problems was not given.

Standards developed by the International Association of Plumbing and Mechanical Officials (IAPMO) have been adopted into the Uniform Solar Energy Code. This code was recently summarized in a roofing industry trade publication [B3]. It was reported that the Uniform Solar Energy Code is intended to provide for safe and functional solar energy systems with a minimum of regulations [B3]. Specific provisions are included for the placement of collectors on roofs. Anchors securing panels should maintain watertightness. The panels should have a minimum of 3 inches (75 mm) clearance from the roof surface. It was not stated in the roofing industry trade publication [B3] whether this provision on clearance applied to low-sloped or pitched roofs. Satisfactory flashing was considered to be the most important part of installing collectors on roofs.

#### B.1 REFERENCES

- B1. "Recommended Requirements to Code Officials for Solar Heating, Cooling and Hot Water Systems," DOE/CS/4281-1, U.S. Department of Energy, In Print.
- B2. "HUD Intermediate Minimum Property Standards Supplement," 1977 Edition, Solar Heating and Domestic Hot Water Systems, 4930.2, Vol. 5, U.S. Department of Housing and Urban Development, (1977).
- B3. "Solar-Roofing Systems - Are They Compatible?," ABC - American Roofer and Building Improvement Contractor, pp. 6 & 7 (December 1977).

#### B.2 NAMES AND ADDRESSES OF MODEL BUILDING CODE ORGANIZATIONS

BOCA Basic Building Code  
Building Administration and Code  
Administration International, Inc.  
1313 East 60th Street  
Chicago, Illinois 60637

Uniform Building Code  
International Conference of  
Building Officials  
5360 South Workman Mill Road  
Whittier, California 90601

Standard Building Code  
Southern Building Code  
Congress, International  
3617 Eighth Avenue, South  
Birmingham, Alabama 35222

U.S. DEPT. OF COMM. <b>BIBLIOGRAPHIC DATA</b> SHEET (See instructions)	1. PUBLICATION OR REPORT NO. NBS TN 1134	2. Performing Organ. Report No.	3. Publication Date November 1980
4. TITLE AND SUBTITLE <p style="text-align: center;">Guidelines for Installation of Solar Components on Low-Sloped Roofs</p>			
5. AUTHOR(S) Robert G. Mathey and Walter J. Rossiter, Jr.			
6. PERFORMING ORGANIZATION (If joint or other than NBS, see instructions) <b>NATIONAL BUREAU OF STANDARDS</b> <b>DEPARTMENT OF COMMERCE</b> <b>WASHINGTON, D.C. 20234</b>		7. Contract/Grant No.	8. Type of Report & Period Covered <p style="text-align: center;">Final</p>
9. SPONSORING ORGANIZATION NAME AND COMPLETE ADDRESS (Street, City, State, ZIP) U.S. Department of Energy Office of Solar Applications for Buildings 1000 Independence Avenue, SW Washington, DC 20585			
10. SUPPLEMENTARY NOTES <p><input type="checkbox"/> Document describes a computer program; SF-185, FIPS Software Summary, is attached.</p>			
11. ABSTRACT (A 200-word or less factual summary of most significant information. If document includes a significant bibliography or literature survey, mention it here) <p>Guidelines were prepared for the installation of solar collectors and related equipment on low-sloped roofs of commercial and industrial type buildings. The guidelines are concerned primarily with the waterproofing integrity of the roofing system, access to the collectors and roofing, attachment of different types of collector support frames and safety. Technical information from the literature, building codes, roofing field surveys and acceptable roofing practice provided the basis for the guidelines. The guidelines include recommendations for the design of the solar installation with regard to roofing performance, workmanship during collector installation and maintenance of roofs with solar components.</p> <p>A field survey was conducted to inspect the condition of low-sloped built-up roofing systems which were retrofitted with solar collector systems. Literature and field surveys were conducted to identify roofing problems attributed to solar equipment installation on roofs and the effect of the installation on roofing performance. The results of the literature and field surveys are presented. Applicable building codes and related documents were examined to obtain information concerning the effect of the installation of solar components on rooftop safety.</p>			
12. KEY WORDS (Six to twelve entries; alphabetical order; capitalize only proper names; and separate key words by semicolons) Collector installation; field survey; guidelines; low-sloped roofs; roofing performance; solar collectors.			
13. AVAILABILITY <input checked="" type="checkbox"/> Unlimited <input type="checkbox"/> For Official Distribution. Do Not Release to NTIS <input checked="" type="checkbox"/> Order From Superintendent of Documents, U.S. Government Printing Office, Washington, D.C. 20402. <input type="checkbox"/> Order From National Technical Information Service (NTIS), Springfield, VA. 22161		14. NO. OF PRINTED PAGES <p style="text-align: center;">81</p> 15. Price <p style="text-align: center;">\$4.00</p>	

# NBS TECHNICAL PUBLICATIONS

## PERIODICALS

**JOURNAL OF RESEARCH**—The Journal of Research of the National Bureau of Standards reports NBS research and development in those disciplines of the physical and engineering sciences in which the Bureau is active. These include physics, chemistry, engineering, mathematics, and computer sciences. Papers cover a broad range of subjects, with major emphasis on measurement methodology and the basic technology underlying standardization. Also included from time to time are survey articles on topics closely related to the Bureau's technical and scientific programs. As a special service to subscribers each issue contains complete citations to all recent Bureau publications in both NBS and non-NBS media. Issued six times a year. Annual subscription: domestic \$13; foreign \$16.25. Single copy, \$3 domestic; \$3.75 foreign.

NOTE: The Journal was formerly published in two sections: Section A "Physics and Chemistry" and Section B "Mathematical Sciences."

**DIMENSIONS/NBS**—This monthly magazine is published to inform scientists, engineers, business and industry leaders, teachers, students, and consumers of the latest advances in science and technology, with primary emphasis on work at NBS. The magazine highlights and reviews such issues as energy research, fire protection, building technology, metric conversion, pollution abatement, health and safety, and consumer product performance. In addition, it reports the results of Bureau programs in measurement standards and techniques, properties of matter and materials, engineering standards and services, instrumentation, and automatic data processing. Annual subscription: domestic \$11; foreign \$13.75.

## NONPERIODICALS

**Monographs**—Major contributions to the technical literature on various subjects related to the Bureau's scientific and technical activities.

**Handbooks**—Recommended codes of engineering and industrial practice (including safety codes) developed in cooperation with interested industries, professional organizations, and regulatory bodies.

**Special Publications**—Include proceedings of conferences sponsored by NBS, NBS annual reports, and other special publications appropriate to this grouping such as wall charts, pocket cards, and bibliographies.

**Applied Mathematics Series**—Mathematical tables, manuals, and studies of special interest to physicists, engineers, chemists, biologists, mathematicians, computer programmers, and others engaged in scientific and technical work.

**National Standard Reference Data Series**—Provides quantitative data on the physical and chemical properties of materials, compiled from the world's literature and critically evaluated. Developed under a worldwide program coordinated by NBS under the authority of the National Standard Data Act (Public Law 90-396).

NOTE: The principal publication outlet for the foregoing data is the Journal of Physical and Chemical Reference Data (JPCRD) published quarterly for NBS by the American Chemical Society (ACS) and the American Institute of Physics (AIP). Subscriptions, reprints, and supplements available from ACS, 1155 Sixteenth St., NW, Washington, DC 20056.

**Building Science Series**—Disseminates technical information developed at the Bureau on building materials, components, systems, and whole structures. The series presents research results, test methods, and performance criteria related to the structural and environmental functions and the durability and safety characteristics of building elements and systems.

**Technical Notes**—Studies or reports which are complete in themselves but restrictive in their treatment of a subject. Analogous to monographs but not so comprehensive in scope or definitive in treatment of the subject area. Often serve as a vehicle for final reports of work performed at NBS under the sponsorship of other government agencies.

**Voluntary Product Standards**—Developed under procedures published by the Department of Commerce in Part 10, Title 15, of the Code of Federal Regulations. The standards establish nationally recognized requirements for products, and provide all concerned interests with a basis for common understanding of the characteristics of the products. NBS administers this program as a supplement to the activities of the private sector standardizing organizations.

**Consumer Information Series**—Practical information, based on NBS research and experience, covering areas of interest to the consumer. Easily understandable language and illustrations provide useful background knowledge for shopping in today's technological marketplace.

*Order the above NBS publications from: Superintendent of Documents, Government Printing Office, Washington, DC 20402.*

*Order the following NBS publications—FIPS and NBSIR's—from the National Technical Information Services, Springfield, VA 22161.*

**Federal Information Processing Standards Publications (FIPS PUB)**—Publications in this series collectively constitute the Federal Information Processing Standards Register. The Register serves as the official source of information in the Federal Government regarding standards issued by NBS pursuant to the Federal Property and Administrative Services Act of 1949 as amended, Public Law 89-306 (79 Stat. 1127), and as implemented by Executive Order 11717 (38 FR 12315, dated May 11, 1973) and Part 6 of Title 15 CFR (Code of Federal Regulations).

**NBS Interagency Reports (NBSIR)**—A special series of interim or final reports on work performed by NBS for outside sponsors (both government and non-government). In general, initial distribution is handled by the sponsor; public distribution is by the National Technical Information Services, Springfield, VA 22161, in paper copy or microfiche form.

## BIBLIOGRAPHIC SUBSCRIPTION SERVICES

The following current-awareness and literature-survey bibliographies are issued periodically by the Bureau:

**Cryogenic Data Center Current Awareness Service.** A literature survey issued biweekly. Annual subscription: domestic \$35; foreign \$45.

**Liquefied Natural Gas.** A literature survey issued quarterly. Annual subscription: \$30.

**Superconducting Devices and Materials.** A literature survey issued quarterly. Annual subscription: \$45. Please send subscription orders and remittances for the preceding bibliographic services to the National Bureau of Standards, Cryogenic Data Center (736) Boulder, CO 80303.