



Lawrence Berkeley Laboratory

UNIVERSITY OF CALIFORNIA

Accelerator & Fusion Research Division

LBL--20181

DE86 002868

Invited talk presented at the International
Conference on X-ray and VUV Synchrotron
Radiation Instrumentation, Stanford, CA,
July 29 - August 2, 1985

**BRIGHTNESS, COHERENCE, AND PROPAGATION
CHARACTERISTICS OF SYNCHROTRON RADIATION**

K.-J. Kim

July 1985

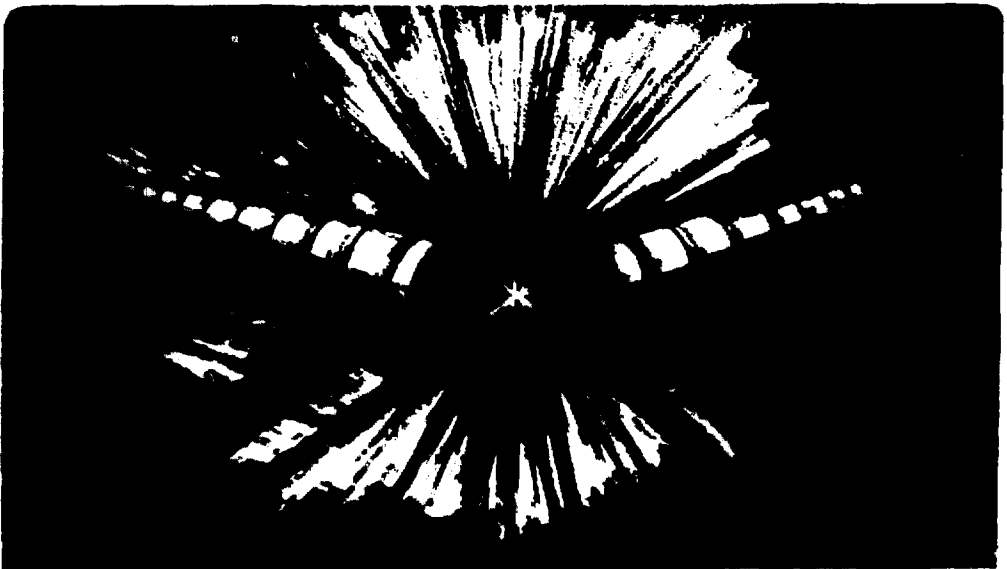

BRIGHTNESS, COHERENCE, AND PROPAGATION
CHARACTERISTICS OF SYNCHROTRON RADIATION

Kwang-Je Kim

Center for X-ray Optics
Lawrence Berkeley Laboratory
University of California
Berkeley, California 94720

Invited talk presented at the
International Conference on X-ray and
VUV Synchrotron Radiation Instrumentation,
July 29-August 2, 1985

Stanford University
Stanford, California

MASTER

DISCLAIMER

This report was prepared as an account of work sponsored by an agency of the United States Government. Neither the United States Government nor any agency thereof, nor any of their employees, makes any warranty, express or implied, or assumes any legal liability or responsibility for the accuracy, completeness, or usefulness of any information, apparatus, product, or process disclosed, or represents that its use would not infringe privately owned rights. Reference herein to any specific commercial product, process, or service by trade name, trademark, manufacturer, or otherwise does not necessarily constitute or imply its endorsement, recommendation, or favoring by the United States Government or any agency thereof. The views and opinions of authors expressed herein do not necessarily state or reflect those of the United States Government or any agency thereof.

This work was supported by the U.S. Department of Energy
under Contract No. DE-AC03-76SF00098.

This report was done with support from the Department of Energy. Any conclusions or opinions expressed in this report represent solely those of the author(s) and not necessarily those of The Regents of the University of California, the Lawrence Berkeley Laboratory or the Department of Energy.

Reference to a company or product name does not imply approval or recommendation of the product by the University of California or the U.S. Department of Energy to the exclusion of others that may be suitable.

**BRIGHTNESS, COHERENCE, AND PROPAGATION
CHARACTERISTICS OF SYNCHROTRON RADIATION***

Kwang-Je Kim

Center for X-ray Optics
Lawrence Berkeley Laboratory
University of California
Berkeley, California 94720

Abstract

A formalism is presented by means of which the propagation and imaging characteristics of synchrotron radiation can be studied, taking into account the effects of diffraction, electron beam emittance, and the transverse and longitudinal extent of the source. An important quantity in this approach is the Wigner distribution of the electric fields, which can be interpreted as a phase-space distribution of photon flux, and thus can be identified with the brightness. When integrated over the angular variables, the brightness becomes the intensity distribution in the spatial variables and when integrated over the spatial variables, it becomes the intensity distribution in angular variables. The brightness so defined transforms through a general optical medium in exactly the same way as in the case of a collection of geometric rays. Finally, the brightness of different electrons adds in a simple way. Optical characteristics of various synchrotron radiation sources - bending magnets, wigglers and undulators, are analyzed using this formalism.

*This work was supported by the U.S. Department of Energy under Contract No. DE-AC03-76SF00098.

I. Introduction

Calculations in Gaussian optics, i.e., geometrical optics with a paraxial approximation, are greatly facilitated by working with the phase-space variables associated with each ray. The density distribution of the rays in phase space, called the brightness, is a useful quantity in describing the propagation properties of a collection of rays through an arbitrary optical medium. The brightness is also important as an invariant characterization of source strength, since the phase-space area is conserved under optical transformation.

The importance of the brightness has been widely recognized in connection with the planning and design of next-generation synchrotron radiation sources. However, the use of brightness in this context has been only qualitative. Thus, the source brightness \mathcal{B} of a synchrotron radiation device is sometimes calculated by means of the following approximate formula:

$$\mathcal{B} \sim \frac{d^2 \mathcal{F}}{d^2 \theta} / (\text{effective source area}), \quad (1)$$

where the quantity $d^2 \mathcal{F} / d^2 \theta$, the angular distribution of the flux, is to be computed from the well-known radiation formula [1], and the effective source area is to be obtained by "properly" adding the contributions from the electron beam size, diffraction effects and, depth of the field effects, etc. However, a rigorous basis upon which Eq. (1) could be based has been lacking so far.

In this paper, we introduce the brightness as a certain Fourier transform of a mutual coherence function of electric fields. The brightness so defined satisfies the same transformation properties as in Gaussian optics and is thus useful in studying the propagation properties of radiation through optical media, taking a full account of the diffraction effects. The formalism permits a quantitative calculation of the source brightness of a synchrotron radiation device.

Section II reviews the properties of Gaussian optics, which serves as a model for later discussions. In Section III, the brightness in a general case is defined in terms of the electric fields, and its transformation properties are described. Section IV discusses the transverse coherence properties in terms of our generalized brightness. A simple application of the formalism to the fundamental optical resonator mode appears in Section V. Section VI establishes an important theorem concerning synchrotron radiation due to a random collection of electrons. Section VII derives an approximate expression for the brightness of undulator radiation by approximating the brightness due to a single electron by the brightness due to a laser mode. Section VIII contains a more rigorous discussion of the source brightness of bending magnets, wigglers, and undulators. Finally, Section IX concludes the paper.

Explicit derivations of formula are often neglected here. They will appear in a future publication.

II. Gaussian Optics

In this section, we review some well-known properties of Gaussian optics as an introduction to the brightness concept.

Consider the problem of finding the intensity distribution at the image plane of the optical system shown in Fig. (1). In Gaussian optics, only those rays that stay close to a reference trajectory, called the optical axis, are considered. The position along the optical axis will be specified by the z-coordinate. A ray passing through a plane transverse to the optical axis at z can be characterized by (x, ϕ) , where x is the position of the ray in the plane and ϕ is the angle between the ray and the optical axis. Although x and ϕ are two-dimensional vectors, we shall suppress the vector notation whenever possible throughout this paper. In passing through an optical medium, a ray changes according to

$$\begin{pmatrix} x \\ \phi \end{pmatrix}_2 = M \begin{pmatrix} x \\ \phi \end{pmatrix}_1, \quad (2)$$

$$M = M_n \cdot M_{n-1} \dots M_1. \quad (3)$$

Here M_i is a 2 x 2 matrix which characterizes a component of the medium and which is given by

$$M_l = \begin{pmatrix} 1 & l \\ 0 & 1 \end{pmatrix} \text{ for free space of length } l, \quad (4)$$

$$M_f = \begin{pmatrix} 1 & 0 \\ -1/f & 1 \end{pmatrix} \text{ for a lense of focal length } f. \quad (5)$$

The brightness $\mathcal{D}(x, \phi; z)$ is defined for each transverse plane at z by

$$\mathcal{D}(x, \phi; z) dx d\phi = \text{number of rays in phase-space area } dx d\phi. \quad (6)$$

Since the number of rays and the element $dx d\phi$ are conserved, one obtains

$$\mathcal{B}(x, \phi; z_2) = \mathcal{B}(x', \phi'; z_1), \begin{pmatrix} x' \\ \phi' \end{pmatrix} = M^{-1} \begin{pmatrix} x \\ \phi \end{pmatrix} \quad (7)$$

Equation (7) gives the transformation properties of the brightness through an arbitrary optical medium. When slits are present, rays that hit the opaque parts should be removed.

A luminous object, or source, can be specified by a function $S(x, \phi; z)$, defined by

$$S(x, \phi; z) dx d\phi dz = \text{the number of rays generated by an infinitesimal section } dz \text{ into the phase space element } dx d\phi. \quad (8)$$

A more convenient way to characterize the source is to provide the brightness $\mathcal{B}(x, \phi; 0)$ referred to a transverse plane within the source at $z = 0$. It is easy to show that

$$\mathcal{B}(x, \phi; 0) = \int dz S(x - z\phi, \phi; z) \quad (9)$$

This will be referred to as the source brightness.

The solution of the general optical problem illustrated in Fig. (1) proceeds as follows: compute the source brightness using Eq. (9). Find the matrix M corresponding to a particular optical medium and determine the brightness at the image plane by Eq. (7). Physically measurable quantities, such as the flux density $d^2\mathcal{I}/d^2x$ and the angular distribution $d^2\mathcal{I}/d^2\phi$, are obtained by integration as follows:

$$\frac{d^2 \mathcal{F}}{d^2 x} = \int \mathcal{B}(x, \theta; z) d^2 \theta \quad ,$$

$$\frac{d^2 \mathcal{F}}{d^2 \theta} = \int \mathcal{B}(x, \theta; z) d^2 x \quad .$$
(10)

III. General Definition of Brightness

The general discussion of brightness, taking into account diffraction effects, starts with the electric field E . Throughout this paper, we shall always consider a narrow bandwidth $\Delta\omega$ about a given frequency ω . (In this sense, the brightness we discuss here is in fact the "spectral" brightness). Also, we shall limit our discussion to a single polarization component because, in synchrotron radiation, usually only the horizontal component is important. Effectively, therefore, the electric field is considered to be a scalar quantity.

Electric fields and brightness are always referred to a certain transverse plane. For notational simplicity, the z dependence will be suppressed whenever possible. Thus, the electric field will be represented by either $E(x)$ or $E(x; z)$. It is convenient to introduce the following Fourier transform pair:

$$E(x) = \int \mathcal{E}(\theta) e^{ik\theta \cdot x} d^2 \theta \quad ,$$

$$\mathcal{E}(\theta) = \frac{1}{\lambda^2} \int E(x) e^{-ik\theta \cdot x} d^2 x \quad .$$
(11)

Here $k = \omega/c = 2\pi/\lambda$, λ being the radiation wavelength. As in Gaussian optics, we make the paraxial approximation $\theta^2 \ll 1$, so that

$$\sqrt{1 - \theta^2} \sim 1 - \theta^2/2 \quad . \quad (12)$$

The wave propagation in free space is then described by the Fresnel diffraction formula given by

$$\mathcal{E}(\theta; z+l) = \mathcal{E}(\theta; z) e^{ik \cdot l(1 - \frac{\theta^2}{2})} \quad , \quad (13)$$

$$E(x; z+l) = \frac{-i}{\lambda l} \int d^2 x' E(x'; z) e^{ik \left(\frac{(x-x')^2}{2l} + l \right)} \quad .$$

The brightness is defined as a bilinear function of the electric field as follows:

$$\mathcal{B}(x, \theta) = \text{const} \int d^2 \xi \langle \mathcal{E}^*(\theta + \frac{\xi}{2}) \mathcal{E}(\theta - \frac{\xi}{2}) \rangle e^{-ikx \cdot \xi} \quad , \quad (14)$$

$$= \frac{\text{const}}{\lambda^2} \int d^2 u \langle E^*(x + \frac{u}{2}) E(x - \frac{u}{2}) \rangle e^{ik\theta \cdot u} \quad .$$

The angular brackets here indicate the ensemble average: they are necessary when the fields fluctuate randomly. The constant in Eq. (14) depends on whether the brightness is defined in terms of power or photon numbers, and need not be specified here.

The brightness defined above is real but not positive definite. Thus its interpretation is not as straightforward as in the case of Gaussian optics. This is fundamentally due to the wave nature of the radiation, which precludes a simultaneous determination of both position and angle, much as in quantum mechanics. In fact, a phase-space

distribution which closely resembles Eq. (14) was first introduced by Wigner [2] some 50 years ago in connection with statistical quantum mechanics. Since then, the representation has been rediscovered and studied by several authors [3] in the context of optics.

We shall now establish that the brightness defined here shares many properties of Gaussian optics. First, one obtains by integration that

$$\int \mathcal{B}(x, \phi) d^2\phi \propto \langle |E(x)|^2 \rangle \quad , \quad (15a)$$

$$\int \mathcal{B}(x, \phi) d^2x \propto \langle |\mathcal{E}(\phi)|^2 \rangle \quad . \quad (15b)$$

The right-hand sides of above equations, which are positive definite, can clearly be identified as the fluxes, and thus Eq. (15) reduces to Eq. (10).

The transformation property under free-space propagation is determined by the Fresnel formula, Eq. (13). Inserting this into Eq. (14), one finds

$$\mathcal{B}(x, \phi; z+l) = \mathcal{B}(x-l\phi, \phi; z) \quad . \quad (16)$$

To find the transformation through a lense of focal length f , we note that the electric field transforms according to

$$E_{\text{after}}(x) = E_{\text{before}}(x) e^{-ikx^2/2f} \quad . \quad (17)$$

From Eq. (17) and Eq. (14), one obtains

$$\mathcal{B}_{\text{after}}(x, \phi) = \mathcal{B}_{\text{before}}\left(x, \phi + \frac{x}{f}\right) \quad . \quad (18)$$

Both Eq. (16) and Eq. (18) are of the form of Eq. (7). Therefore, the transformation properties of the brightness defined here are the same as in Gaussian optics. The result can be generalized to the case of a continuous medium.

When slits are present, diffraction effects could become important, and the transformation properties are modified compared to the Gaussian case.

IV. Transverse Coherence

The brightness as given by Eq. (14) is a Fourier transformation of the mutual coherence function defined at a transverse plane. Therefore brightness provides another convenient description of the properties of transverse coherence. As a matter of fact, the free-space transformation, Eq. (16), is equivalent to the well-known Zernike-Van-Cittert theorem [4].

Kondratenko and Skrinsky [5] have introduced the concept of the transversely coherent flux \mathcal{F}_{Coh} , as that part of the flux which is able to exhibit interference phenomena. Our definition of brightness can make their argument precise, as follows: Fig. (2) shows radiation generated by a partially coherent, extended source, propagating through two symmetrically located pinholes and forming an interference pattern on a screen. The coherent flux \mathcal{F}_{Coh} may be defined as the flux reaching the shaded area integrated over ϕ , the angle subtended by the pinholes. It then follows that

$$\begin{aligned}
 \mathcal{F}_{\text{coh}} &= \int d^2\theta \langle \mathcal{E}^*(\theta) \mathcal{E}(-\theta) \rangle \\
 &= \int d^2\theta |\mathcal{B}(x,0) e^{2ikx} \theta dx| \\
 &\geq \left(\frac{\lambda}{2}\right)^2 \mathcal{B}(0,0)
 \end{aligned} \tag{19}$$

V. An Example: Fundamental Mode of Optical Resonator

A simple example of our general discussion is provided by the fundamental mode of an optical resonator. Choosing $z=0$ to be the location of the waist, and using the known expression for the electric field [6], one finds that

$$\mathcal{B}(x, \theta; z) = \frac{\mathcal{F}}{(2\pi\sigma_r\sigma_{r'})^2} e^{-\frac{1}{2} \left(\frac{(x-z\theta)^2}{\sigma_r^2} + \frac{\theta^2}{\sigma_{r'}^2} \right)}, \tag{20}$$

where \mathcal{F} is the total flux and σ_r and $\sigma_{r'}$ are related by

$$2\pi\sigma_r\sigma_{r'} = \frac{\lambda}{2}. \tag{21}$$

Notice that Eq. (20) automatically satisfies Eq. (16). Computing the coherent flux \mathcal{F}_{coh} , we find that the equality in Eq. (19) holds in this case, and thus

$$\mathcal{F}_{\text{coh}} = \mathcal{B}(0,0) \left(\frac{\lambda}{2}\right)^2. \tag{22}$$

From Eq. (20) and (21), it then follows that

$$\mathcal{F}_{\text{coh}} = \mathcal{F} . \quad (23)$$

In other words, we found the intuitively reasonable result that the total flux is coherent for the fundamental mode.

VI. Synchrotron Radiation Due to Many Electrons and an Addition

Theorem

The electric field at $z=0$ associated with a fast-moving electron (MKS units) is

$$\mathcal{E}(\phi; 0) = \frac{e}{4\pi\epsilon_0 c} \frac{2\pi}{\lambda} \int \frac{cdt}{\lambda} \underline{n} \times (\underline{n} \times \underline{\beta}(t)) e^{i\omega(t - \underline{n} \cdot \underline{r}/c)} . \quad (24)$$

Here ϵ_0 is the vacuum dielectric constant, \underline{n} is the direction vector whose transverse component is ϕ and whose axial component is

$$n_z = 1 - \phi^2/2 ,$$

and \underline{r} and $c\underline{\beta}$ are, respectively, the position and the velocity of the electron trajectory. Inserting Eq. (24) into Eq. (14), we have now an explicit expression for the source brightness due to a single electron. This will be discussed further in later sections, but the purpose here is to discuss an important theorem for a random collection of electrons, as found in an electron storage ring.

The motion of electrons in storage rings is very much analogous to the propagation of rays in Gaussian optics. Corresponding to the brightness, we introduce the phase-space distribution function f of electrons, which, at symmetric points around the ring, is of the form

$$f(x_e, \phi_e) = \frac{1}{2\pi\sigma_x\sigma_\phi} e^{-\frac{1}{2} \left(\frac{x_e^2}{\sigma_x^2} + \frac{\phi_e^2}{\sigma_\phi^2} \right)} . \quad (25)$$

The produce $\sigma_x\sigma_\phi$ is known as the emittance. Equation (25) gives the probability distribution of electrons in phase space (x_e, ϕ_e) .

The theorem, which will be called the addition theorem, will be stated here without proof; let \mathcal{B}^0 be the source brightness of the reference electron. The source brightness due to all electrons is then given by

$$\mathcal{B}(x, \phi) = N_e \int \mathcal{B}^0(x-x_e, \phi-\phi_e) f(x_e, \phi_e) d^2x_e d^2\phi_e , \quad (26)$$

where N_e is the total number of electrons. The conditions necessary for Eq. (26) are that different electrons are statistically independent and that the variation of the magnetic guide field across the electron beam dimensions is negligible. Both of these are well-satisfied by the usual synchrotron radiation sources.

VII. Approximation of Undulator Radiation by Laser Mode

The expression for the source brightness of undulator radiation is somewhat involved, and it is useful to approximate it by the laser mode discussed in Section V. To identify σ_r and σ_r' with the undulator parameters, we first determine σ_r' from the undulator angular distribution and write [7]

$$\sigma_r' = \sqrt{\frac{\lambda}{L}} = \sqrt{\frac{1 + K^2/2}{2\gamma^2 \lambda_n}} . \quad (27)$$

where L is the length of the undulator, K is the deflection parameter, γ is the electron energy/rest energy, n is the harmonic number, and N is the number of the undulator periods. From Eq. (21), one obtains

$$\sigma_r = \frac{1}{4\pi} \sqrt{\lambda L} \quad , \quad (28)$$

which is the diffraction-limited source size. The undulator brightness of a single electron is then approximated by Eq. (20), with σ 's given by Eq. (27) and Eq. (28).

We now use the addition theorem to obtain the brightness corresponding to a beam of electrons. The integral (26) in this case is a convolution of two Gaussian functions, and one obtains

$$\mathcal{B}(\underline{x}, \underline{\phi}) = \mathcal{F} \frac{e^{-\frac{1}{2} \left(\frac{x^2}{\sigma_{Tx}^2} + \frac{y^2}{\sigma_{Ty}^2} + \frac{\phi^2}{\sigma_{T\phi}^2} + \frac{\psi^2}{\sigma_{T\psi}^2} \right)}}{(2\pi)^2 \sigma_{Tx} \sigma_{Ty} \sigma_{T\phi} \sigma_{T\psi}} \quad . \quad (29)$$

In this and the following sections, we will restore the two-dimensional notation; $x \rightarrow \underline{x} = (x, y)$ and $\phi \rightarrow \underline{\phi} = (\phi, \psi)$, and

$$\begin{aligned} \sigma_{Tx} &= \sqrt{\sigma_r^2 + \sigma_x^2} \quad , \quad \sigma_{Ty} = \sqrt{\sigma_r^2 + \sigma_y^2} \\ \sigma_{T\phi} &= \sqrt{\sigma_r^2 + \sigma_\phi^2} \quad , \quad \sigma_{T\psi} = \sqrt{\sigma_r^2 + \sigma_\psi^2} \quad . \end{aligned} \quad (30)$$

An expression for the undulator brightness was first derived by Krinsky [7] using an intuitive approach. His equation is similar to

Eq. (29), except that his σ_r is larger by a factor 2π , and his expression includes an additional term in σ_{Tx} and σ_{Ty} which represents the depth of field effects due to electron beam angular divergence. The latter term is implicit in the transformation property of the electron beam phase space, and thus should not appear in Eq. (30).

The source strength of an undulator may be characterized by the peak brightness $\mathcal{B}(0,0)$. Reference [8] contains the brightness of various synchrotron radiation sources computed in this way.

VIII. Source Brightness of Synchrotron Radiation

Let us now turn to a more rigorous derivation of the source brightness of synchrotron radiation due to a single electron based on Eq. (24) and Eq. (14). The electron trajectory is assumed to lie in the horizontal plane, and the coordinate system is explained in Fig. (3).

Bending Magnets and Wigglers

Using the same approximation that Schwinger [9] uses for his derivation of the radiation from bending magnets, one finds that the source brightness is given by

$$\mathcal{B}(\underline{x}, \underline{\phi}) = \frac{d^2 \mathcal{F}}{d\phi d\mathbf{r}} \delta(x - \bar{x}(\phi) + \phi \bar{z}(\phi)) \delta(y + \psi \bar{z}(\phi)) \quad (31)$$

Here, $d^2 \mathcal{F} / d\phi d\mathbf{r}$ is the well-known angular distribution of the flux, and $\bar{x}(\phi)$ and $\bar{z}(\phi)$ are the coordinates of the point on the trajectory where its slope coincides with ϕ , as shown in Fig. (4). According to Eq. (31), photons are emitted incoherently in the tangential direction

at each point of the trajectory. However, the formula breaks down and the diffraction effect becomes important when

$$|y + \bar{z}(\phi)| \text{ and } |x - \bar{x}(\phi) + \phi \bar{z}(\phi)| < \rho \left(\frac{\lambda}{\rho}\right)^{2/3}, \quad (32)$$

where ρ is the instantaneous radius of the curvature. Equation (31) is analogous to, but simpler than, Green's classical analysis [10], in which he incorporated the diffraction effect on the basis of an intuitive argument.

Undulators

Although the general expression for undulator brightness is rather complicated, one obtains the following approximate expression when

$N \gg \infty$:

$$\mathcal{B}(\underline{x}, \underline{\phi}) = \mathcal{B}(0,0) \frac{1}{\pi} \int_0^1 dz \int_{-(1-z)}^{(1-z)} d\ell \frac{\sin((\phi'z + x')^2/\ell - \ell\phi'^2)}{\ell}, \quad (33)$$

where

$$\underline{\phi}' = \underline{\phi} / \sqrt{\frac{\lambda}{L\pi}}, \quad \underline{x}' = \underline{x} / \sqrt{\lambda L/4\pi}. \quad (34)$$

The integral in Eq. (33) can be evaluated numerically [11], and the result is shown in Fig. (5) for a particular case where $\underline{\phi}$ and \underline{x} are parallel. One notices that a Gaussian approximation will be poor. The non-Gaussian nature of the undulator brightness also manifests itself in the expression of the peak brightness:

$$\mathcal{B}(0,0) = \frac{\mathcal{F}}{\lambda^2/2} \quad . \quad (35)$$

This is to be compared with the result of Section V, where we obtained $\mathcal{B}(0,0) = \mathcal{F}/(\lambda^2/4)$ for a Gaussian mode.

The implication of the non-Gaussian nature of the brightness distribution is being investigated.

IX. Conclusions

In this paper, we have presented a formalism which provides a rigorous theoretical basis for calculating optical properties of synchrotron radiation. The brightness defined here has the same transformation properties as in Gaussian optics, and it provides a convenient description of the coherence characteristics of synchrotron radiation. Furthermore, the addition theorem shows how the incoherent phase space of electrons and the coherent phase space of radiation can be added in a simple fashion.

Acknowledgments

I thank M. Blume for pointing out that Eq. (14) is basically the Wigner distribution, E. Wolf for stimulating discussions and for providing me with many references on the Wigner distribution in the context of optics, and S. Krinsky for discussions which led to the calculations reported in Section VII.

References

- [1] See, for example, J.D. Jackson, Classical Electrodynamics (John Wiley and Sons, Inc., 1962).
- [2] E. Wigner, Phys. Rev. 40 (1932) 749.
- [3] A. Walther, J. Opt. Soc. Am. 58 (1968) 1256. E. Wolf, J. Opt. Soc. Am. 68 (1978) 6.
- [4] M. Born and E. Wolf, Principle of Optics, 6th ed. (Pergamon Press, Oxford, New York, 1980).
- [5] A.M. Kondratenko and A.N. Skrinsky, Opt. Spectrosc., 42 (1977) 189.
- [6] A. Yariv, Quantum Electronics, 2nd ed. (John Wiley and Sons, Inc., 1975).
- [7] S. Krinsky, IEEE Trans. Nucl. Sci. NS-30 (1983) 3078.
- [8] D.T. Attwood and K-J. Kim, these proceedings.
- [9] J. Schwinger, Phys. Rev. 75 (1949) 1912.
- [10] G.K. Green, Spectra and Optics of Synchrotron Radiation (1976) BNL 50522.
- [11] The integration in Eq. (33) can be made well behaved by going to the complex plane. I thank K. Halbach for pointing this out.

Figure Captions

Fig. 1. A general problem in optics.

Fig. 2. An illustration of transverse coherence.

Fig. 3. The coordinate system.

Fig. 4. An illustration of Eq. (31). The radiation emitted at P is projected to the reference plane at $z=0$ to find the source coordinate.

Fig. 5. The function $B(x, \phi)/B(0,0)$ when \underline{x} and $\underline{\phi}$ are parallel.

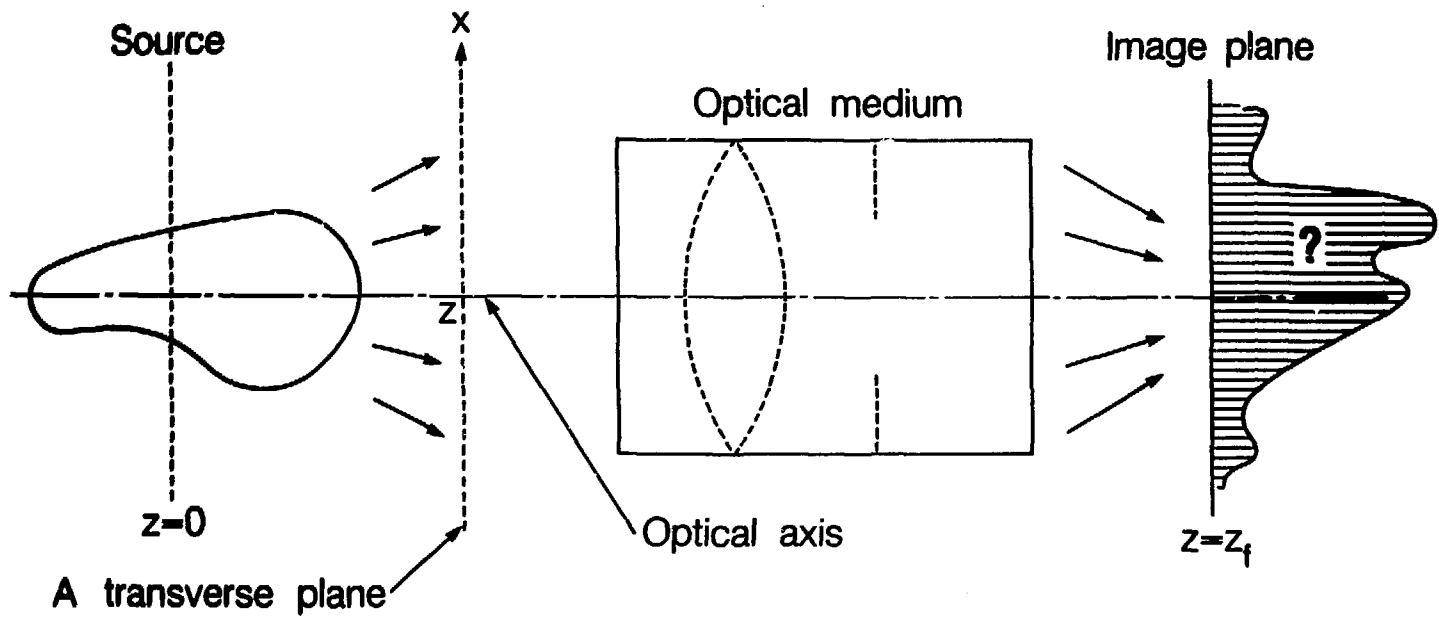

XBL 858-9341

Fig. 1

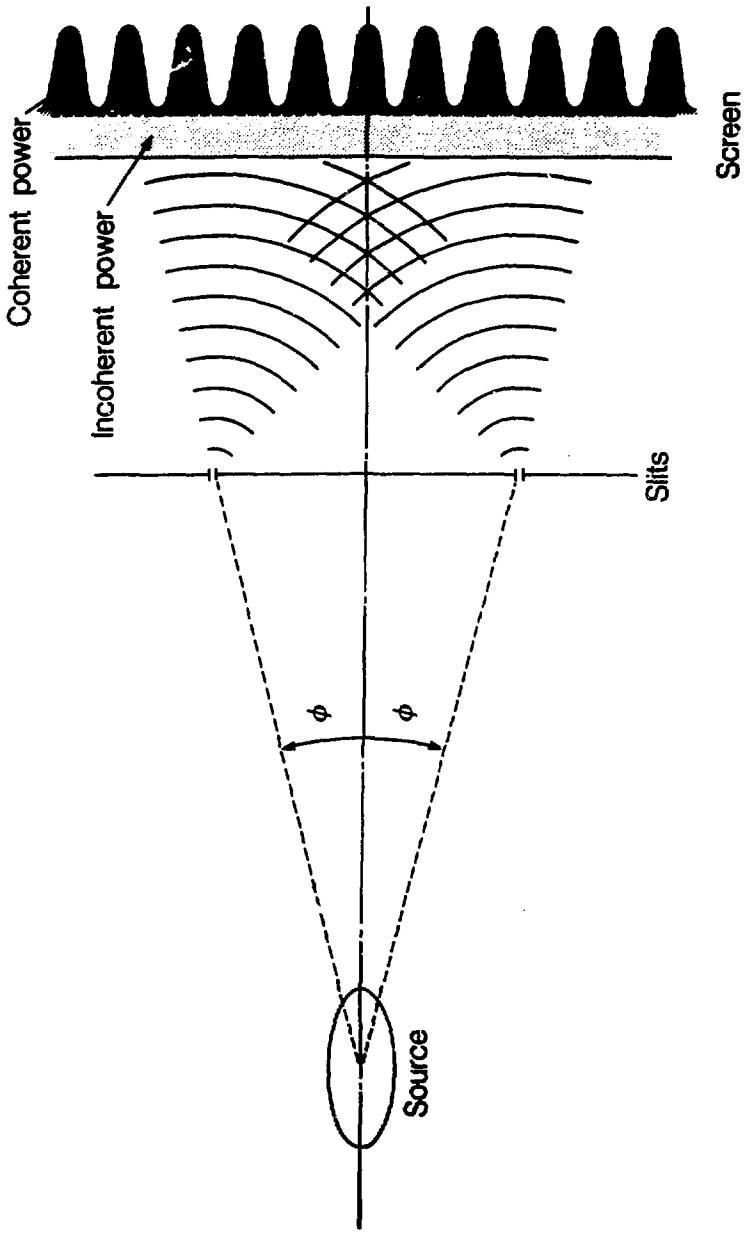

XBL 858-9338

Fig. 2

Coordinate system

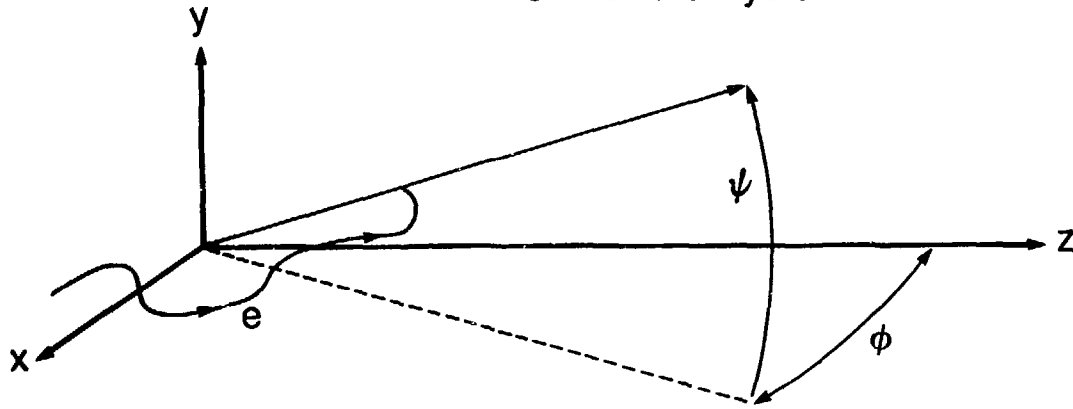

XBL 858-9339

Fig. 3

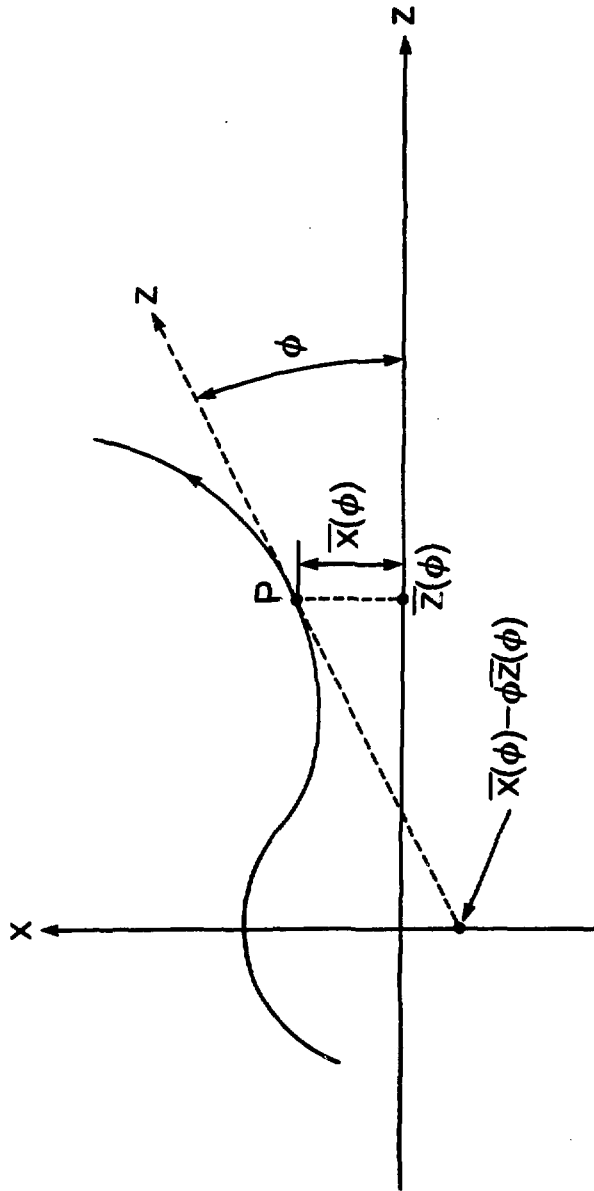

XBL 858-9340

Fig. 4

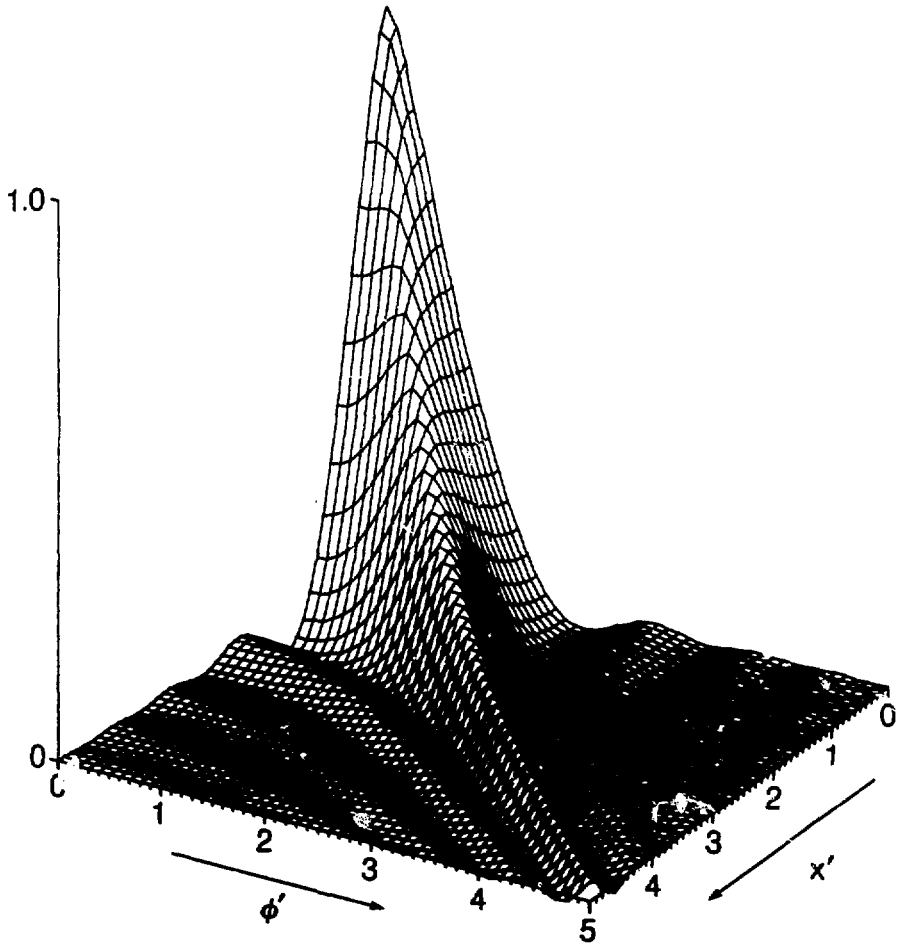

Fig. 5