

SOLAR-ENERGY-SYSTEM PERFORMANCE EVALUATION

DE83 008826

SCATTERGOOD SCHOOL
RECREATION CENTER,
WEST BRANCH, IOWA

JUNE 1978 THROUGH APRIL 1979

KENNETH L. SHENFISH, PRINCIPAL AUTHOR
W. H. McCUMBER, MANAGER OF PERFORMANCE ANALYSIS
LARRY J. MURPHY, IBM PROGRAM MANAGER

IBM CORPORATION
150 SPARKMAN DRIVE
HUNTSVILLE, ALABAMA 35805

NOTICE
PORTIONS OF THIS REPORT ARE ILLEGIBLE.
It has been reproduced from the best
available copy to permit the broadest
possible availability.

PREPARED FOR THE
DEPARTMENT OF ENERGY
OFFICE OF ASSISTANT
SECRETARY FOR
CONSERVATION AND SOLAR APPLICATIONS
UNDER CONTRACT EG-77-C-01-4049
H. JACKSON HALE, PROGRAM MANAGER

DISCLAIMER

This report was prepared as an account of work sponsored by an agency of the United States Government. Neither the United States Government nor any agency thereof, nor any of their employees, makes any warranty, express or implied, or assumes any legal liability or responsibility for the accuracy, completeness, or usefulness of any information, apparatus, product, or process disclosed, or represents that its use would not infringe privately owned rights. Reference herein to any specific commercial product, process, or service by trade name, trademark, manufacturer, or otherwise does not necessarily constitute or imply its endorsement, recommendation, or favoring by the United States Government or any agency thereof. The views and opinions of authors expressed herein do not necessarily state or reflect those of the United States Government or any agency thereof.

DISCLAIMER

Portions of this document may be illegible in electronic image products. Images are produced from the best available original document.

TABLE OF CONTENTS

SECTION	TITLE	PAGE
1.	FOREWORD.	1
2.	SUMMARY AND CONCLUSIONS	3
3.	SYSTEM DESCRIPTION.	7
4.	PERFORMANCE EVALUATION TECHNIQUES	11
5.	PERFORMANCE ASSESSMENT.	13
5.1	Weather Conditions	14
5.2	System Thermal Performance	16
5.3	Subsystem Performance.	20
5.3.1	Collector Array Subsystem	21
5.3.2	Storage Subsystem	31
5.3.3	Hot Water Subsystem	37
5.3.4	Space Heating Subsystem	40
5.4	Operating Energy	48
5.5	Energy Savings	51
6.	REFERENCES.	55
APPENDIX A	DEFINITION OF PERFORMANCE FACTORS AND SOLAR TERMS	A-1
APPENDIX B	SOLAR ENERGY SYSTEM PERFORMANCE EQUATIONS FOR SCATTERGOOD SCHOOL.	B-1
APPENDIX C	LONG-TERM AVERAGE WEATHER CONDITIONS.	C-1

LIST OF FIGURES AND TABLES

FIGURE	TITLE	PAGE
3-1	Scattergood School Solar Energy System Schematic.	8
5.3.1-1	Collector Array Arrangement.	24
5.3.1-2	Collector Array Operating Point Histogram and Instantaneous Efficiency Curves	29
5.3.2-1	Solar System and Recreational Building Temperature Profiles	35
5.3.4-1	Building Heat Loss Coefficient Determination	43
5.3.4-2	Solar System and Recreational Building Temperature Profiles	45
5.3.4-3	Heat Loss Coefficient Determination for Scattergood School Recreation Center	47

TABLE	TITLE	PAGE
5.1-1	Weather Conditions	15
5.2-1	System Thermal Performance	17
5.2-2	Solar Energy System Coefficients of Performance	18
5.3.1-1	Collector Array Performance	22
5.3.1-2	February Energy Gain Comparison	25
5.3.1-3	Annual Energy Gain Comparison	27
5.3.2-1	Storage Subsystem Performance	33
5.3.3-1	Hot Water Subsystem Performance	38
5.3.4-1	Heating Subsystem Performance	41
5.4-1	Operating Energy	49
5.5-1	Energy Savings	52

NATIONAL SOLAR DATA PROGRAM REPORTS

Reports prepared for the National Solar Data Program are numbered under a specific format. For example, this report for the Scattergood School Recreation Center project site is designated as SOLAR/2003-79/14. The elements of this designation are explained in the following illustration.

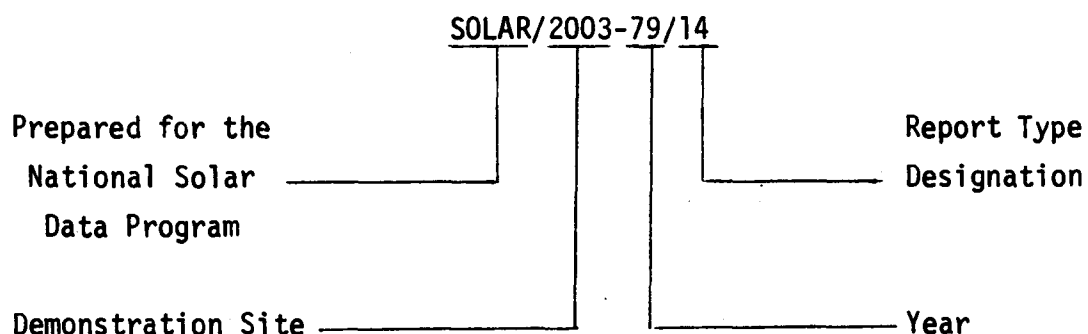

- **Demonstration Site Number:**

Each Project site has its own discrete number - 1000 through 1999 for residential sites and 2000 through 2999 for commercial sites.

- **Report Type Designation:**

This number identifies the type of report, e.g.,

- Monthly Performance Reports are designated by the numbers 01 (for January) through 12 (for December).
- Solar Energy System Performance Evaluations are designated by the number 14.
- Solar Project Descriptions are designated by the number 50.
- Solar Project Cost Reports are designated by the number 60.

These reports are disseminated through the U. S. Department of Energy, Technical Information Center, P. O. Box 62, Oak Ridge, Tennessee 37830.

1. FOREWORD

The National Program for Solar Heating and Cooling is being conducted by the Department of Energy under the Solar Heating and Cooling Demonstration Act of 1974. The overall goal of this activity is to accelerate the establishment of a viable solar energy industry and to stimulate its growth in order to achieve a substantial reduction in non-renewable energy resource consumption through widespread applications of solar heating and cooling technology.

Information gathered through the Demonstration Program is disseminated in a series of site-specific reports. These reports are issued as appropriate and may include such topics as:

- Solar Project Description
- Design/Construction Report
- Project Costs
- Maintenance and Reliability
- Operational Experience
- Monthly Performance
- System Performance Evaluation

The International Business Machines Corporation is contributing to the overall goal of the Demonstration Act by monitoring, analyzing, and reporting the thermal performance of solar energy systems through analysis of measurements obtained by the National Solar Data Program.

The System Performance Evaluation Report is a product of the National Solar Data Program. Reports are issued periodically to document the results of analysis of specific solar energy system operational performance. This report includes system description, operational characteristics and capabilities, and an evaluation of actual versus expected performance. The Monthly Performance Report, which is the basis for the System Performance Evaluation Report, is published on a regular basis. Each parameter

presented in these reports as characteristic of system performance represents over 8,000 discrete measurements obtained each month by the National Solar Data Network.

All reports issued by the National Solar Data Program for the Scattergood School Recreation Center solar energy system are listed in Section 6, References.

This Solar Energy System Performance Evaluation Report presents the results of a thermal performance analysis of the Scattergood School Recreation Center solar energy system. The analysis covers operation of the system from June 1978 through April 1979. The Scattergood School Recreation Center solar energy system provides space heating and hot water preheating for a recreation building located in West Branch, Iowa. A more detailed system description is contained in Section 3. Analysis of the system thermal performance was accomplished using a system energy balance technique described in Section 4. Section 2 presents a summary of the results and conclusions obtained while Section 5 presents a detailed assessment of the system thermal performance.

Acknowledgements are extended to those individuals involved in the operation of the Scattergood School Recreation Center solar energy system. Their insight and cooperation in the resolution of various on-site problems during the reporting period were invaluable.

2. SUMMARY AND CONCLUSIONS

This System Performance Evaluation Report provides an operational summary of the solar energy system installed at the Scattergood School Recreation Center located at West Branch, Iowa. This analysis is conducted by evaluation of measured system performance and by comparison of measured weather data with long-term average climatic conditions. The performance of major subsystems is also presented.

The measurement data were collected [Reference 13]* by the National Solar Data Network (NSDN) [1] for the period June 1978 through April 1979. System performance data are provided through the NSDN via an IBM-developed Central Data Processing System (CDPS) [2]. The CDPS supports the collection and analysis of solar data acquired from instrumented systems located throughout the country. This data is processed daily and summarized into monthly performance reports. These monthly reports form a common basis for system evaluation and are the source of the performance data used in this report.

Features of this report include: a system description, a review of actual system performance during the report period, analysis of performance based on evaluation of meteorological load and operational conditions, and an overall discussion of results.

The Scattergood School solar energy site was installed on June 16, 1977. The data communications system was brought on line June 25, 1977. The solar system has operated almost continuously since then except for three periods of time. The first period occurred between December 10, 1977 and February 21, 1978 when the hot water system was inactive because of a hot water heat exchanger failure; the second period was between April 2, 1978 and April 14, 1978 when a power relay failed; and the last period was during January 1979 when snow prevented normal operation of the collector subsystem. In each case, the solar system was returned to normal operation.

*Numbers in brackets designate References found in Section 6.

Monthly values of average daily insolation and average outdoor temperature measured at the Scattergood School Recreation Center solar energy site are presented in Table 5.1-1. Also presented in the Table are the long-term, average monthly values for these weather parameters.

Temperatures during the 11-month reporting period were slightly below average with a measured average outdoor ambient temperature of 45°F versus the long-term average ambient of 49°F. However, the January and February measured ambient temperatures were considerably below normal, averaging about 12°F below the long-term average ambient for the period. For this reason, the measured heating degree-days (7,584) were 20 percent greater than the long-term heating degree-days (6,305). The cooling degree-days were also below normal. The average daily insolation measured in the plane of the collector array was 1,247 Btu/ft² which was eight percent lower than the long-term daily average of 1,355 Btu/ft². These measured weather conditions indicate a cloudy and cold winter in the West Branch area.

During this reporting period, the solar energy system achieved a net space heating energy savings of 230.99 million Btu of fossil energy (2,525 gallons of propane) or a cost savings of \$1,136.25, assuming a cost of \$0.45 per gallon for propane. A total of 9.87 million Btu (2,892 kwh) of electrical energy was required to operate the system. The hot water electrical savings of 3.76 million Btu (1,102 kwh) reduced the electrical energy cost to 6.11 million Btu (1,790 kwh) or a cost of \$89.50, assuming a cost of \$0.05 per kwh. Thus, the net solar energy system savings were \$1,046.75.

The collector array subsystem performance was greater than design predictions for the subsystem. A total of 1,037.52 million Btu of incident solar energy was measured in the plane of the collector array during the reporting period. At times when the collector array was operating, there was

624.82 million Btu incident on the array. The system collected 220.09 million Btu, which represents an operational collector array efficiency of 35 percent.

The rock bed performance this heating season was greater than the performance of the past heating season and near the predicted performance for the subsystem. A total of 70.68 million Btu was delivered to storage during the reporting period and 57.38 million Btu were removed from storage to meet the load demands. A total of 13.23 million Btu was lost from the rock bed which translates into a rock bed efficiency of 81 percent. Additional analysis revealed that about 70 percent of the rock bed losses contributed to the reduction of the building heat transfer coefficient by raising the temperature of the wall between the conditioned space and the shed enclosing the rock bed. Thus, the rock bed losses contributed to meeting the space heating demand.

The average storage heat loss coefficient was 78 Btu/Hr-°F which was close to the estimated heat loss coefficient of 82 Btu/Hr-°F. The estimated heat loss coefficient was determined from insulation properties of the rock bed. The performance of the rock bed was further enhanced by a low level flow of energy from the rock bed to the gymnasium at night. By design, the default positions of the control dampers are such that the rock bed is open to the gymnasium. A large cold gymnasium and hot rock bed allowed natural convection to move warm air from the rock bed to the gymnasium.

The DHW subsystem at the Scattergood Recreation Center operated continuously throughout the reporting period. For the 11-month period, June 1978 through April 1979, the solar energy system supplied a total of 21.53 million Btu to the domestic hot water load. The total hot water load for this period was 3.91 million Btu and the average monthly solar fraction was 46 percent. The performance of the hot water preheat subsystem was low during the winter months, December 1978 through April 1979. The principal reason for this situation was a low hot water demand coupled with the large solar tank losses that exist during these months.

The space heating load for the reporting period was 132.68 million Btu. Solar Energy supplied 108.13 million Btu of this load and the remaining 24.55 million Btu were supplied by auxiliary fossil fuel heaters. This resulted in a heating solar fraction of 81 percent and a net savings of 184.21 million Btu of fossil fuel (2,013 gallons of propane).

The solar energy system at Scattergood was operated in the grain drying mode in October 1978. The grain drying subsystem utilizes the collectors to heat outside air, which is then passed to a propane heater/fan that supplies the remaining energy required to raise the temperature of the air to a level sufficient to reduce the moisture in the grain silo. The indicated solar energy supplied to the grain drying operation was 32.87 Million Btu. An expense of 0.77 million Btu of electrical operating energy was incurred in support of the grain drying process. Operation of the system resulted in a propane fuel savings of 599 gallons, or 54.78 million Btu, based on an assumed efficiency of 60 percent for the propane system.

In general, the Scattergood School solar energy system performed well during the reporting period. The performance of the Scattergood School solar energy system was greater than the predicted performance. This was due to the superior performance of the collector array and storage subsystems. The performance of the hot water subsystem was degraded due to the low consumption of hot water during this reporting period. The only other problems of significance were a leaky air control damper (10 percent leak rate) that allowed air to be transferred to the recreation center when operating in the domestic hot water heating mode, and a leaky collector transport system that lost approximately 23 percent of the solar energy collected during the reporting period. These problems should be repaired, if possible, to improve the performance of the solar energy system.

An analysis of the heat transfer associated with the site has been made. These results are presented in Figure 5.3.4-3 to indicate the behavior of the building as it is presently constructed and its interaction with the solar energy system.

3. SYSTEM DESCRIPTION

This solar energy system is installed at Scattergood School near West Branch, Iowa, which is located 35 miles southeast of Cedar Rapids, Iowa. The system is designed to supply approximately 75 percent of the annual space heating requirements for the gymnasium, as well as 75 percent of the hot water for the student locker room (References [9] and [12]). This solar energy system is also used to dry grain in a modified grain silo located on the site adjacent to the gymnasium. The site has an array of 128 flat-plate collectors, manufactured by Solaron, with a gross area of 2,496 square feet. The collectors face south at an angle of 50 degrees from the horizontal. Collected solar energy is stored in a pebble bed containing 64 tons of stones for space heating and in two 120-gallon tanks to permit DHW preheating. Air is the medium used for transferring energy from the collector array to the pebble bed or directly to the gymnasium.

When solar energy is insufficient for space heating, two 250K Btu propane gas heaters furnish auxiliary energy. Auxiliary heating for hot water is provided by a 52-gallon domestic water heater containing standard electric resistance, immersion heater elements. The solar energy system is manually converted to summer mode operation by opening and closing slide gate dampers which isolate the storage from the solar energy system. The control system switch then is positioned to the summer mode.

The system, shown schematically in Figure 3-1, has five modes of solar operation.

Mode 1 - Collector-to-Space Heating: This winter mode is entered when two conditions occur simultaneously. The first condition occurs when the collector outlet temperature exceeds the gymnasium temperature by at least 45°F. The second condition occurs when there is a space heating demand indicated by the manually preset, two-stage thermostat. The air heated by

- I001 COLLECTOR PLANE TOTAL INSOLATION
- D001 WIND DIRECTION
- V001 WIND SPEED
- ▶ T001 OUTDOOR TEMPERATURE
- RH001 OUTDOOR RELATIVE HUMIDITY

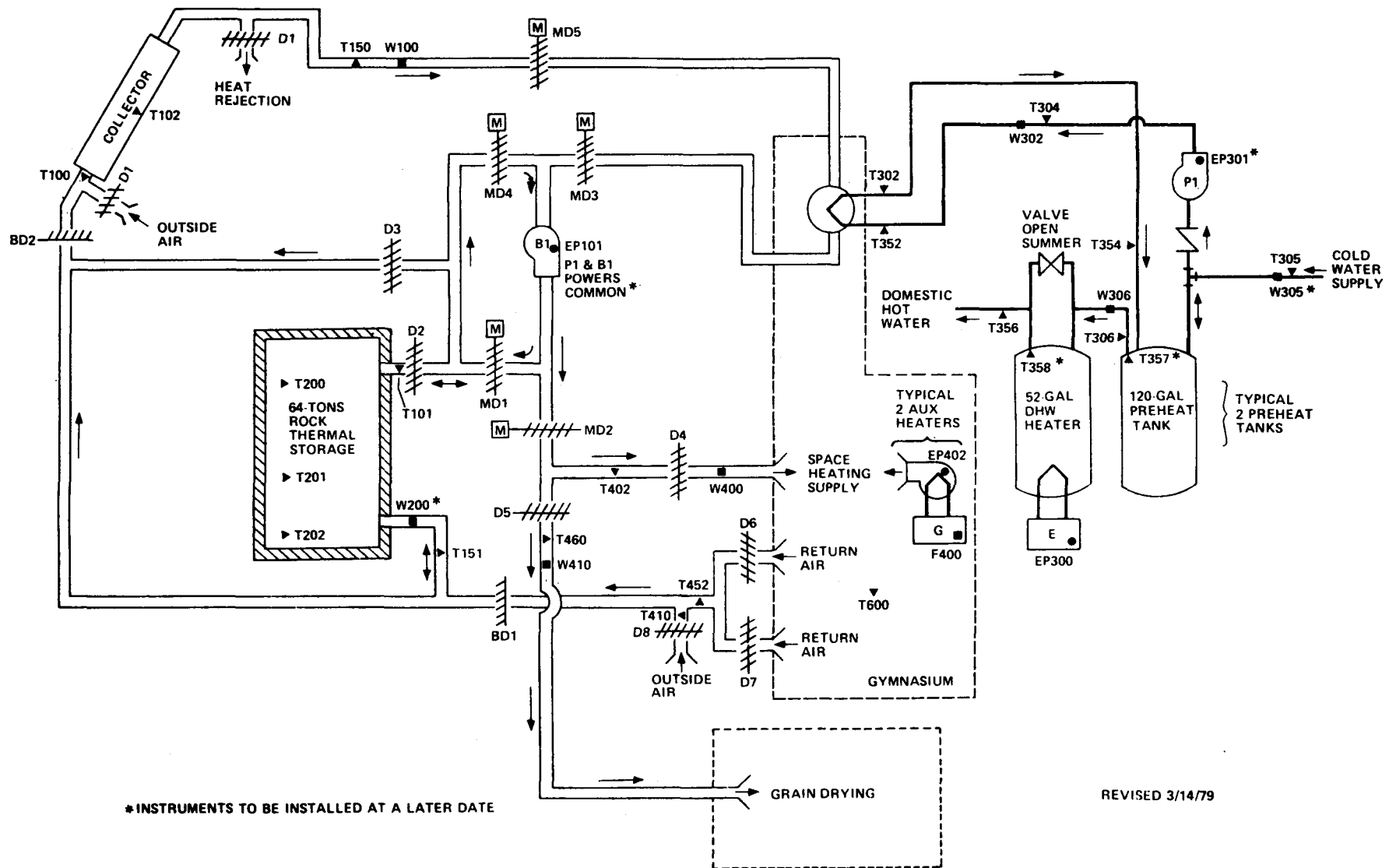

Figure 3-1. SCATTERGOOD SCHOOL SOLAR ENERGY SYSTEM SCHEMATIC

the collector is circulated by the air-handling unit between the collector array and the gymnasium through ducts containing motorized dampers. In this mode, the heated air bypasses the rock thermal storage as it returns to the collector array. This mode continues until either the collector array outlet temperature no longer exceeds the collector array inlet temperature by at least 30°F, or the demand for space heating is satisfied. Stage one of the thermostat operates when solar energy is needed, and stage two operates in conjunction with stage one to activate the auxiliary heaters to supplement solar energy when the gymnasium temperature drops below a level determined by the thermostat setting.

Mode 2 - Storage-to-Space Heating: This winter mode is entered when these three conditions occur simultaneously: 1) there is a demand for space heating, 2) the collector loop is not active, and 3) the temperature in the rock thermal storage is 90°F or higher. Air is drawn through the ducts from storage and circulated through the air-handling unit to the conditioned space and returned to storage; the air bypasses the collector.

Mode 3 - Collector-to-Storage: This winter mode is entered when the difference in temperature between the collector array outlet and the gymnasium temperature is 45°F, or higher, and Mode 1 is not required. Heated air is drawn from the collector array, via the air-handling unit, and is circulated between rock thermal storage and the collectors. This mode continues until the collector array outlet temperature no longer exceeds the collector array inlet temperature by at least 30°F.

Mode 4 - Collector-to-Water Preheating: This summer operation mode is entered when two conditions are met. The first condition is that there is a request for hot water. The second condition occurs when the collector array outlet temperature exceeds the gymnasium temperature by 45°F. Heated air drawn from the collector array is circulated via the air-handling unit through the ducts past an air-to-liquid heat exchanger and returned to the collector array (the air bypasses the rock thermal storage). Simultaneous to collector array air

flow, pump P1 is turned on and DHW preheat tank water is circulated through the air-to-liquid heat exchanger, where solar energy is used to increase the temperature of the DHW preheat tank. This mode continues until the temperature in the preheat tanks reaches 140°F, or until the collector array outlet temperature no longer exceeds the collector array inlet temperature by at least 30°F. This preheated water is stored in two 120-gallon tanks and delivered on demand to the 52-gallon DHW heater. Water can also be preheated in Modes 1 and 3 during the heating season, when energy collection is occurring and a hot water demand exists.

Mode 5 - Grain Drying: This manually controlled winter mode is utilized to reduce the moisture of grain stored in a bin near the gymnasium. This mode operates in the fall and spring to utilize excess solar energy. Manual dampers D8 and D5 (Figure 3-1) are opened, and manual dampers D4, D6 and D7 are closed. This action provides a path for outside air to be drawn by the air-handling unit through the collector array, where it is heated, and then supplied to the grain bin. The mode is entered by raising the gymnasium thermostat to artificially produce a demand for space heating to the control system. The mode is terminated manually either after solar energy is exhausted, or after the grain reaches the desired dryness.

4. PERFORMANCE EVALUATION TECHNIQUES

The performance of the Scattergood School Recreation Center solar energy system is evaluated by calculating a set of primary performance factors which are based on those proposed in the intergovernmental agency report "Thermal Data Requirements and Performance Evaluation Procedures for the National Solar Heating and Cooling Demonstration Program" [3]. These performance factors quantify the thermal performance of the system by measuring the amount of energies that are being transferred between the components of the system. The performance of the system can then be evaluated based on the efficiency of the system in transferring these energies.

Data from monitoring instrumentation located at key points within the solar energy system are collected by the National Solar Data Network. This data is first formed into factors showing the hourly performance of each system component, either by summation or averaging techniques, as appropriate. The hourly factors then serve as a basis for the calculation of the daily and monthly performance of each component subsystem.

Each month a summary of overall performance of the Scattergood School Recreation Center site and a detailed subsystem analysis are published. Monthly reports for the period covered by this System Performance Evaluation, June 1978 through April 1979, are available from the Technical Information Center, Oak Ridge, Tennessee 37830.

Blank Page

5. PERFORMANCE ASSESSMENT

The performance of the Scattergood School Recreation Center solar energy system has been evaluated for the June 1978 through April 1979 time period. Two perspectives have been taken in this assessment. The first looks at the overall system view in which the total solar energy collected, the system load and the measured values for solar energy used and system solar fraction are presented. Also presented, where applicable, are the expected values for solar energy used and system solar fraction. The expected values have been derived from a modified f-chart* analysis which uses measured weather and subsystem loads as inputs. The model used in the analysis is based on manufacturers' data and other known system parameters. In addition, the solar energy system coefficient of performance (COP) at both the system and subsystem level has been presented. The second view presents a more in-depth look at the performance of individual components. Details relating to the performance of the collector array and storage subsystems are presented first, followed by details pertaining to the space heating subsystem. Included in this area are all parameters pertinent to the operation of each individual subsystem.

The performance assessment of any solar energy system is highly dependent on the prevailing weather conditions at the site during the period of performance. The original design of the system is generally based on the long-term averages for available insolation and temperature. Deviations from these long-term averages can significantly affect the performance of the system. Therefore, before beginning the discussion of actual system performance, a presentation of the measured and long-term averages for critical weather parameters has been provided.

*f-chart is the designation of a procedure for designing solar heating systems. It was developed by the Solar Energy Laboratory, University of Wisconsin-Madison.

5.1. Weather Conditions

Average values of the daily incident solar energy in the plane of the collector array and the average outdoor temperature measured at the Scattergood School Recreation Center site during the report period are presented in Table 5.1-1.

Also presented in Table 5.1-1 are the corresponding long-term average monthly values of the measured weather parameters. These data are taken from Reference Monthly Environmental Data for Systems in the National Solar Data Network [4]. A complete yearly listing of these values for the site is given in Appendix C.

Monthly values of heating and cooling degree-days are derived from daily values of ambient temperature. They are useful indications of the system heating and cooling loads. Heating degree-days and cooling degree-days are computed as the difference between daily average temperature and 65°F. For example, if a day's average temperature was 60°F, then five heating degree-days are accumulated. Likewise, if a day's average temperature was 80°F, then 15 cooling degree-days are accumulated. The total number of heating and cooling degree-days are summed monthly.

During the 11-month period from June 1978 through April 1979, a daily average of 1,247 Btu/Ft² of solar energy was incident on the collector array. This was eight percent below the expected long-term daily average of 1,355 Btu/Ft². The measured average ambient temperature for the period was 45°F, which was four degrees below the long-term average of 49°F.

During January, winter storms deposited a considerable amount of snow on the Scattergood Recreation Building. The snow prevented normal operation of the collector array for substantial periods during the month. This caused a performance reduction of the solar energy system.

TABLE 5.1-1
WEATHER CONDITIONS

Month	Daily Incident Solar Energy Per Unit Area (50° Tilt) (Btu/Ft ² -day)		Ambient Temperature (°F)		Heating Degree-Days		Cooling Degree-Days	
	Measured	Long-Term Average	Measured	Long-Term Average	Measured	Long-Term Average	Measured	Long-Term Average
Jun 78	1,596	1,579	71	71	10	21	185	193
Jul 78	1,330	1,604	73	75	0	0	232	302
Aug 78	1,618	1,608	72	73	2	11	207	258
Sep 78	1,623	1,561	68	65	76	82	161	68
Oct 78	1,313	1,487	50	54	480	345	0	16
Nov 78	866	1,080	37	39	825	783	0	0
Dec 78	844	844	21	26	1,369	1,200	0	0
Jan 79	868	1,017	7	21	1,796	1,392	0	0
Feb 79	1,486	1,274	13	25	1,455	1,109	0	0
Mar 79	1,025	1,391	33	35	976	920	0	0
Apr 79	1,151	1,458	45	50	595	442	0	0
Total	--	--	--	--	7,584	6,305	785	837
Average	1,247	1,355	45	49	689	573	71	76

5.2 System Thermal Performance

The thermal performance of a solar energy system is a function of the total solar energy collected and applied to the system load. The total system load is the sum of the energy requirements, both solar and auxiliary thermal, for each subsystem. The portion of the total load provided by solar energy is defined to be the solar fraction of the load. This solar fraction is the measure of performance for the solar energy system when compared to design or expected solar contribution.

The thermal performance of the Scattergood School Recreation Center solar energy system is presented in Table 5.2-1 and Table 5.2-2. This performance assessment is based on the 11-month period from June 1978 through April 1979.

During the 11-month reporting period, a total of 220.09 million Btu of solar energy was collected and the total system load was 169.46 million Btu. The measured amount of solar energy delivered to the loads was 162.51 million Btu, which was three percent greater than the expected value. The measured system solar fraction of 84 percent was six percent greater than the expected value of 79 percent. The increased performance of the Scattergood School solar energy system over that predicted is due to the superior performance of the collector array and storage subsystems and the unusual manner in which the building was operated. The solar energy control system at Scattergood School operates only during the time that solar energy is available to maintain the gymnasium at 60°F. The control system for the auxiliary heaters is manually overridden to maintain lower temperatures in the gymnasium, and to minimize propane consumption. The heaters are used only when solar energy is unavailable for long periods. The heaters are also used to maintain a minimum temperature of 45°F. In the afternoons and evenings, students using the gym turn the heaters on to maintain a comfortable temperature.

The solar energy system COP (defined as the total solar energy delivered to the load divided by the total system operating energy) was 16.56 for the 11-month period. The collector array subsystem COP and the space heating

TABLE 5.2-1
SYSTEM THERMAL PERFORMANCE

Month	Solar Energy Collected (Million Btu)	System Load (Million Btu)	Solar Energy Used (Million Btu)		Solar Fraction (Percent)	
			Expected	Measured	Expected	Measured
Jun 78	9.49	5.41	8.3	8.05	100	98
Jul 78	8.16	3.92	6.5	6.47	100	99
Aug 78	10.23	3.89	6.7	6.70	100	100
Sep 78	9.76	3.81	7.1	6.83	100	99
Oct 78	47.05	5.15	29.0*	6.60	72	93
Nov 78	18.21	12.88	12.5	13.10	82	92
Dec 78	21.50	17.68	13.6	15.13	67	81
Jan 79	17.95	19.70	14.0	12.06	64	58
Feb 79	32.09	29.55	26.9	22.88	80	73
Mar 79	24.81	20.06	17.5	17.99	74	84
Apr 79	20.84	14.54	15.1	13.83	91	86
Total	220.09	136.59*	157.2*	129.64*	---	---
Average	20.01	12.42*	14.3*	11.79*	79*	77*

* Grain drying operations utilized 32.87 million Btu of solar energy. Thus, the system load was actually 169.46 million Btu, the solar energy used 162.51 million Btu, and the solar fraction 84 percent when grain drying operations are included in the totals.

TABLE 5.2-2
SOLAR ENERGY SYSTEM COEFFICIENTS OF PERFORMANCE

Month	Solar Energy System COP	Collector Array Subsystem COP	Domestic Hot Water Subsystem Solar COP	Space Heating Subsystem Solar COP
Jun 78	11.37	24.17	12.28	63.38
Jul 78	9.11	19.25	11.69	105.00
Aug 78	9.14	22.92	11.13	195.79
Sep 78	10.67	25.39	13.46	167.73
Oct 78	20.59	57.81	6.67	47.42
Nov 78	20.50	46.79	9.41	125.16
Dec 78	18.25	64.18	6.45	41.56
Jan 79	18.90	72.87	5.38	44.74
Feb 79	17.31	58.36	6.06	40.92
Mar 79	19.08	55.73	7.02	53.63
Apr 79	18.79	48.94	8.18	87.68
Total Period	16.56	45.37	9.15	54.23

subsystem solar COP for the total period were 45.37 and 54.23, respectively. The hot water system solar COP was 9.15 for the total period. These values again relate the amount of solar energy associated with a particular subsystem to the amount of electrical energy required to operate that subsystem. As such, the COP serves as an indicator of both how well the system was designed and how well it operated. At Scattergood School, the collector and space heating subsystems are operating very efficiently as indicated by the high solar COP's. However, the hot water COP of 9.15 indicates the domestic hot water system was not as efficient as the other subsystems.

It is interesting to note the strong influence that the local weather conditions had on the measured solar fraction. For example, the measured average outdoor ambient temperatures in both January 1979 and February 1979 were 12 degrees below the long-term average. In January the measured insolation was 17 percent below the long-term average and the measured solar fraction was 58 percent. However, in February the measured insolation was 16 percent above the long-term average and the measured solar fraction was 73 percent. This result occurred even though the February measured heating load (29.6 million Btu) was greater than the January measured heating load (19.7 million Btu). The variation of the heating loads is probably due to variable infiltration rates during the month combined with effects on the building heat transfer characteristics that occurred because of the great amounts of snow in January. These observations serve to reinforce the statement in the Performance Assessment section concerning the impact of prevailing weather conditions on the performance of a solar energy system.

5.3 Subsystem Performance

The Scattergood School Recreation Building solar energy installation may be divided into four subsystems:

- 1) Collector array
- 2) Storage
- 3) Hot Water
- 4) Space Heating.

Each subsystem is evaluated by the techniques defined in Section 4 and is numerically analyzed each month for the monthly performance reports. This section presents the results of integrating the monthly data available on the four subsystems for the period June 1978 through April 1979.

5.3.1 Collector Array Subsystem

Collector array performance is described by comparison of the collected solar energy to the incident solar energy. The ratio of these two energies represents the collector array efficiency which may be expressed as

$$\eta_c = Q_s / Q_i \quad (1)$$

where: η_c = Collector Array Efficiency (CAREF)

Q_s = Collected Solar Energy (SECA)

Q_i = Incident Solar Energy (SEA).

The gross collector array area is 2,496 square feet. The measured monthly values of incident solar energy, collected solar energy, and collector array efficiency are presented in Table 5.3.1-1.

Evaluation of collector efficiency using operational incident energy and compensating for the difference between gross collector array area and the gross collector area yields operational collector efficiency. Operational collector efficiency, η_{co} , is computed as follows:

$$\eta_{co} = Q_s / \left(Q_{oi} \times \frac{A_p}{A_a} \right) \quad (2)$$

where: Q_s = Collected Solar Energy (SECA)

Q_{oi} = Operational Incident Energy (SEOP)

A_p = Gross Collector Area (product of the number of collectors and the total envelope area of one unit) (GCA)

A_a = Gross Collector Array Area (total area perpendicular to the solar flux vector including all mounting, connecting and transport hardware (GCAA).

Note: The ratio $\frac{A_p}{A_a}$ is typically 1.0 for most collector array configurations.

TABLE 5.3.1-1
COLLECTOR ARRAY PERFORMANCE

Month	Incident Solar Energy (Million Btu)	Collected Solar Energy (Million Btu)	Collector Array Efficiency	Operational Incident Energy (Million Btu)	Operational Collector Efficiency
Jun 78	119.50	9.49	0.08	61.04	0.16
Jul 78	102.92	8.16	0.08	53.03	0.15
Aug 78	125.22	10.23	0.08	57.46	0.18
Sep 78	121.54	9.76	0.08	53.90	0.18
Oct 78	101.60	47.05	0.46	85.22	0.55
Nov 78	64.87	18.21	0.28	42.98	0.42
Dec 78	65.31	21.50	0.33	47.97	0.43
Jan 79	67.22	17.95	0.27	41.87	0.43
Feb 79	103.85	32.09	0.31	79.90	0.42
Mar 79	79.30	24.81	0.31	55.15	0.45
Apr 79	86.19	20.84	0.24	47.30	0.44
Total	1,037.52	220.09	--	624.82	--
Average	94.32	20.01	0.21	56.80	0.35

This latter efficiency term is not the same as collector efficiency as represented by the ASHRAE Standard 93-77 [5]. Both operational collector efficiency and the ASHRAE collector efficiency are defined as the ratio of actual useful energy collected to solar energy incident upon the collector and both use the same definition of collector area. However, the ASHRAE efficiency is determined from instantaneous evaluation under tightly controlled, steady state test conditions, while the operational collector efficiency is determined from the actual conditions of daily solar energy system operation. Measured monthly values of operational incident energy and computed values of operational collector efficiency are also presented in Table 5.3.1-1.

Collector Array efficiency may be viewed from two perspectives. The first assumes that the efficiency be based upon all available solar energy; however, that point of view makes the operation of the control system a part of array efficiency. For example, energy may be available at the collector, but the collector fluid temperature is below the control minimum, thus the energy is not collected. The monthly efficiency computed by this method is listed in the column entitled "Collector Array Efficiency" in Table 5.3.1-1.

The second viewpoint assumes the efficiency be based upon only the incident energy during periods of collection. The monthly efficiency computed by this method is listed in the column entitled "Operational Collector Array Efficiency." Efficiency computed by this method is used in the following discussion.

The Scattergood School Recreation Building collector array consists of 128 Solaron 2000-series flat-plate air collectors arranged in two functional paths. There are 32 parallel rows containing two collectors in series in each functional path (Reference [12]). This arrangement is shown schematically in Figure 5.3.1-1. Table 5.3.1-2 presents a comparison of the actual performance of the collector array for the month of February against four predictions of performance, which are based on instantaneous efficiency curves.

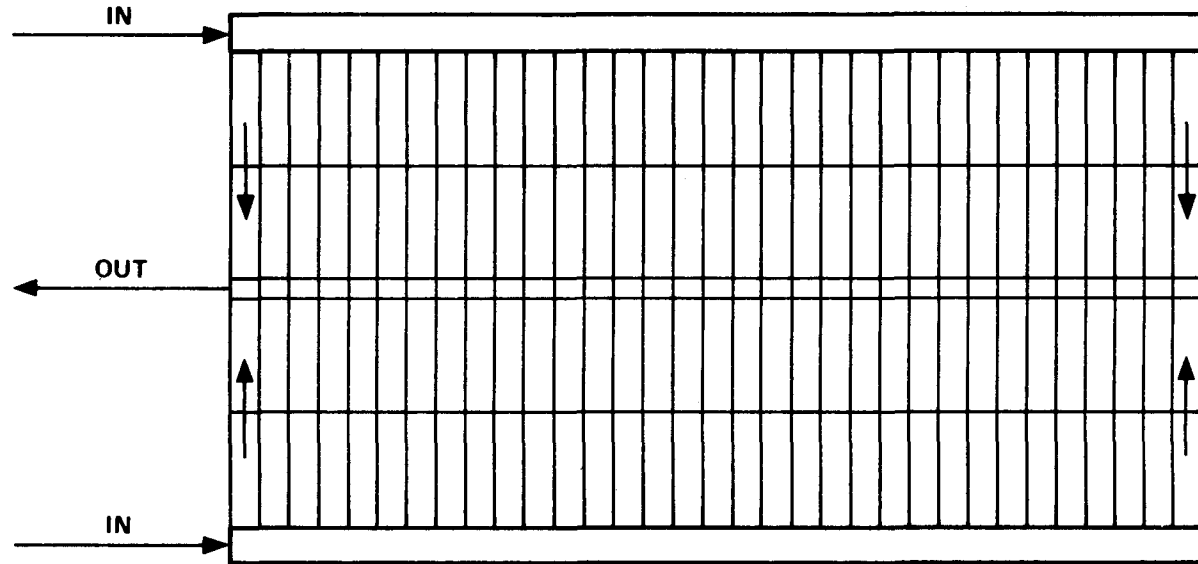

Figure 5.3.1-1. COLLECTOR ARRAY ARRANGMENT

TABLE 5.3.1-2

ENERGY GAIN COMPARISON
FEBRUARY

SITE: SCATTERGOOD SCHOOL

WEST BRANCH, IOWA

DAY	ACTUAL	ERROR			
		FIELD DERIVED			LAB
		MONTH	LONG TERM	2ND ORDER	PANEL
1	1.345E+06	0.536	0.668	0.217	0.483
2	0.000E+00	0.000	0.000	0.000	0.000
3	9.267E+05	0.849	1.279	0.596	0.831
4	1.090E+06	0.349	0.558	0.149	0.319
5	1.749E+06	0.042	0.020	-0.006	0.001
6	6.402E+05	0.023	-0.026	-0.011	-0.041
7	1.790E+06	-0.066	-0.049	-0.101	-0.111
8	1.527E+06	-0.322	-0.301	-0.352	-0.366
9	9.604E+05	-0.270	-0.208	-0.254	-0.265
10	4.847E+04	0.453	0.278	0.183	0.452
11	2.345E+05	0.203	0.256	0.180	0.152
12	1.385E+06	0.279	0.287	0.159	0.215
13	8.592E+05	0.059	0.032	0.040	-0.002
14	0.000E+00	0.000	0.000	0.000	0.000
15	0.000E+00	0.000	0.000	0.000	0.000
16	2.074E+06	0.092	0.082	0.060	0.073
17	1.312E+06	-0.029	-0.011	-0.052	-0.076
18	3.841E+05	0.051	0.041	-0.002	-0.006
19	1.733E+06	-0.105	-0.148	-0.136	-0.161
20	1.738E+06	-0.079	-0.131	-0.123	-0.110
21	1.532E+06	-0.059	-0.128	-0.115	-0.124
22	0.000E+00	0.000	0.000	0.000	0.000
23	1.829E+06	0.092	0.002	0.005	0.015
24	1.773E+06	0.177	0.098	0.096	0.098
25	2.504E+06	0.103	0.107	0.110	0.090
26	2.055E+06	0.198	0.129	0.131	0.119
27	1.178E+06	0.160	0.142	0.095	0.096
28	6.600E+05	0.190	0.101	0.124	0.108
	3.152E+07	0.062	0.039	-0.005	0.002

CURVE	COEFFICIENTS			
	A0 (PHTA)	A1 (FHLL)	A2 (*)	R**2
PANEL	0.520	-0.622	N.A.	N.A.
MONTH	0.473	-0.501	N.A.	0.117
LT1ST	0.513	-0.937	N.A.	0.546
LT2ND	0.592	-1.008	2.571	N.A.

February was chosen as the example month because the measured insolation was 16 percent above the long-term average and the collector array was operational for 24 of 28 days during the month.

Instantaneous efficiency curves are derived from laboratory test data supplied by the collector manufacturer (Reference [8]) and from three empirical sources: a linear regression line fit through field data obtained in February; a linear regression line fit through all field data in the base; and a curvilinear (second order) regression line fit through all field data in the base (the base data consists of all measurements relating to collector array performance made from September 1978 through April 1979 as shown in Table 5.3.1-3).

Each error value presented in the error field of Tables 5.3.1-2 and 5.3.1-3 is computed by the equation

$$\text{error} = (A - P) / P \quad (3)$$

where:

A = The actual energy gain of the collector array shown in column one (million Btu/day).

P = The predicted energy gain of the collector array based on projecting the measured operating point to the applicable instantaneous efficiency curve and multiplying by the measured insolation level and collector array area and then summing over all the measured operating points (million Btu/day).

The computed error is then a measure of how well the particular prediction curve fits the reality of dynamic operating conditions in the field.

Examination of the performance of the collector array reveals that the Scattergood School Collector array performance was almost perfectly predicted by the manufacturer's instantaneous efficiency curve, and deviated by only six percent from the monthly and long-term predictions. This is indicative of a well-designed collector array.

TABLE 5.3.1-3

ENERGY GAIN COMPARISON
(ANNUAL)

SITE: SCATTERGOOD SCHOOL

WEST BRANCH, IOWA

MONTH	YEAR	ACTUAL	ERROR			
			FIELD DERIVED			LAS
			MONTH	LONG TERM	2ND ORDER	PANEL
JANUARY	79	1.357E+07	0.474	0.116	0.125	0.076
FEBRUARY	79	3.193E+07	0.062	0.059	0.061	0.002
MARCH	79	2.473E+07	0.041	0.056	0.057	0.059
APRIL	79	2.073E+07	0.076	0.078	0.079	0.050
MAY		0.000E+00	0.000	0.000	0.000	0.000
JUNE		0.000E+00	0.000	0.000	0.000	0.000
JULY		0.000E+00	0.000	0.000	0.000	0.000
AUGUST		0.000E+00	0.000	0.000	0.000	0.000
SEPTEMBER	78	6.360E+06	0.188	0.188	-0.104	-0.326
OCTOBER	78	4.483E+07	0.024	0.030	0.029	0.133
NOVEMBER	78	1.819E+07	0.048	0.104	0.106	0.070
DECEMBER	78	2.016E+07	0.003	0.066	0.072	0.065
AVERAGE		2.256E+07	0.079	0.078	0.079	0.056

CURVE	COEFFICIENTS			
	A0 (FRTA)	A1 (FRUL)	A2 (*)	R**2
PANEL	0.520	-0.632	N.A.	N.A.
MONTH	0.515	-0.663	N.A.	0.567
LT1ST	0.563	-0.976	N.A.	0.739
LT2ND	0.565	-1.000	0.061	N.A.

Table 5.3.1-3 represents the heating season collector array performance. The performance results indicate that the collector array performed better than predicted for all months except September 1978. The overall collector performance was six percent higher than the single panel performance prediction. The coefficients of the instantaneous efficiency curves derived from field data are tabulated in Table 5.3.1-3. The coefficients indicate that the performance of the collector array during February was quite close to the predicted performance of a single collector panel. Also tabulated are the coefficients of the performance curves for the 1977-1978 and 1978-1979 heating seasons. The data indicate that the performance of the collector array at Scattergood School is consistent from heating season to heating season. The close agreement indicates that the performance data is adequate for design purposes.

Figure 5.3.1-2 presents a histogram of the collector array operating points for February. Also presented in Figure 5.3.1-2 are linear instantaneous efficiency curves based on controlled laboratory test data supplied by the collector manufacturer, field data for the month of February and long-term field data for the base periods of the last two heating seasons. The ordinate of the graph shown in Figure 5.3.1-2 has a printed range of 0 to 10 percent to display the distribution of collector array operating points. However, the value printed on the ordinate should be multiplied by 10 when the intercepts of the linear instantaneous efficiency curves are being evaluated (these values range from 0 to 100 percent).

The collector array operating points, X , are calculated each scan by the equation

$$X = (T_{f,i} - T_a) / I \quad (4)$$

where:

$T_{f,i}$ is the inlet temperature of the collector array transport fluid ($^{\circ}\text{F}$)

T_a is the temperature of the ambient air ($^{\circ}\text{F}$)

SCATTERGOOD SCHOOL

WEST BRANCH, ICWA

COLLECTOR TYPE: FLAT PLATE AIR

COLLECTOR MODEL: SOLAREN 2001

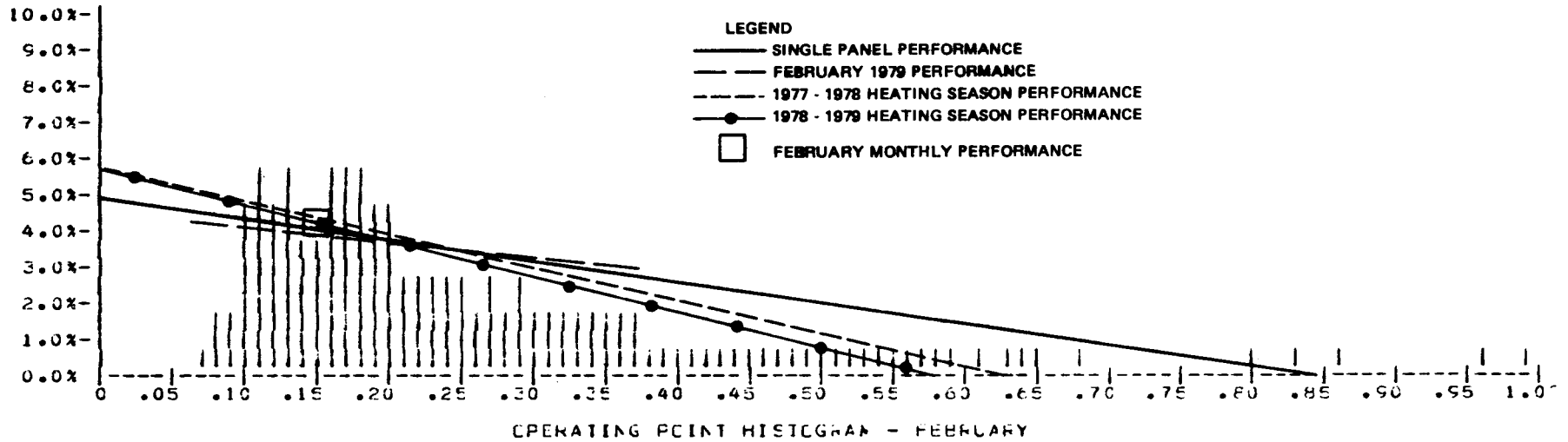

AIR PROPERTIES

AVERAGE LOCAL BAROMETRIC PRESSURE 14.70 PSI
AVERAGE LOCAL RELATIVE HUMIDITY 70.00
AVERAGE TEMPERATURE 36.20 DEGR FAHRENHEIT
ARRAY FLOW RATE 4725.13 CUBIC FEET/MIN
PANEL FLOW RATE 73.83 CUBIC FEET/MIN
AVERAGE TEMPERATURE GAIN 50.69 DEGR FAHRENHEIT
LONG TERM CURVE FIT VALID FROM 0.069 TO 0.304 .

Figure 5.3.1-2. COLLECTOR ARRAY OPERATING POINT HISTOGRAM AND INSTANTANEOUS EFFICIENCY CURVES

I is the insolation rate (Btu/Ft²-Hr).

Examination of the operating point histogram indicates that the predominant region of collector array operation occurred for operating points between 0.10 to 0.20 (58 percent of the time). This leads to the expectation that the operational collector array efficiency would typically be on the order of 0.43, which is in agreement with the data presented in Table 5.3.1-1 for the months of the heating season.

The long-term first order curve shown in Figure 5.3.1-2 has a slightly steeper slope than the curve derived from single panel laboratory test data. This is attributable to higher losses resulting from array effects. However, the projected intercept on the ordinate axis containing collector efficiency of either heating season performance curve indicates that the collector performance during the winter months is greater than that expected. This increased collector performance enabled the overall system to exceed the expected performance of the system.

Additional information concerning collector array analysis in general may be found in a forthcoming paper [7] that describes collector array analysis procedures in detail and presents the results of analysis performed on numerous collector array installations across the United States.

5.3.2 Storage Subsystem

Storage subsystem performance is described by comparison of energy to storage, energy from storage and change in stored energy. The ratio of the sum of energy from storage and change in stored energy to energy to storage is defined as storage efficiency, η_s . This relationship is expressed in the equation

$$\eta_s = (\Delta Q + Q_{so})/Q_{si} \quad (5)$$

where:

ΔQ = Change in stored energy. This is the difference in the estimated stored energy during the specified reporting period, as indicated by the relative temperature of the storage medium (either positive or negative value) (STECH).

Q_{so} = Energy from storage. This is the amount of energy extracted by the load subsystem from the primary storage medium (STEO).

Q_{si} = Energy to storage. This is the amount of energy (both solar and auxiliary) delivered to the primary storage medium (STEI).

Evaluation of the system storage performance under actual transient system operation and weather conditions can be performed using the parameters listed above. The utility of these measured data in evaluation of the overall storage design can be illustrated in the derivation presented below.

The overall thermal properties of the storage subsystem design can be derived empirically as a function of storage average temperature (average storage temperature for the reporting period) and the ambient temperature in the vicinity of the storage tank.

An effective storage heat transfer coefficient (C) for the storage subsystem can be defined as follows:

$$C = (Q_{si} - Q_{so} - \Delta Q_s) / [(\bar{T}_s - \bar{T}_a) \times t] \frac{\text{Btu}}{\text{Hr-}^\circ\text{F}} \quad (6)$$

where:

C = Effective storage heat transfer coefficient

Q_{si} = Energy to storage (STEI)

Q_{so} = Energy from storage (STEO)

ΔQ_s = Change in stored energy (STECH)

\bar{T}_s = Storage average temperature (TS)

\bar{T}_a = Average ambient temperature in the vicinity of storage (TE)

t = Number of hours in the month (HM).

The effective storage heat transfer coefficient is comparable to the heat loss rate defined in ASHRAE Standard 94-77 [6]. It has been calculated for each month in this report period and included, along with Storage Average Temperature, in Table 5.3.2-1.

Examination of the values for the effective storage heat transfer coefficient shows that the variation is quite significant. The storage bed heat loss is lowest during the coldest winter months and highest during the spring and fall. Overall, the heat loss coefficient is quite low which is indicative of a properly performing rock storage bed. This is verified by the high average storage efficiency of 81 percent. The mean storage heat transfer coefficient for these months was 78 Btu/Hr-°F, but the standard deviation (obtained using N-1 weighting) was 41 Btu/Hr-°F. The exact reasons for this variation are not

TABLE 5.3.2-1
STORAGE SUBSYSTEM PERFORMANCE

Month	Energy To Storage (Million Btu)	Energy From Storage (Million Btu)	Change In Stored Energy (Million Btu)	Storage Efficiency	Storage Average Temperature (°F)	Bldg Temp (°F)	Shed Temp (°F)	Effective Storage Heat Loss Coefficient (Btu/Hr-°F)
Jun 78	*	*	*	*	NA	NA	NA	*
Jul 78	*	*	*	*	NA	NA	NA	*
Aug 78	*	*	*	*	NA	NA	NA	*
Sep 78	*	*	*	*	NA	NA	NA	*
Oct 78	7.03	2.94	1.05	0.57	85	63	59.6	160.87
Nov 78	8.74	8.39	-1.60	0.78	100	62	55.2	60.45
Dec 78	10.50	8.94	-0.23	0.83	69	56	39.4	81.28
Jan 79	5.80	4.03	0.63	0.81	61	53	28	46.43
Feb 79	15.58	13.79	-0.10	0.88	80	60	35.9	63.78
Mar 79	14.85	12.74	-0.18	0.85	82	60	48.6	92.15
Apr 79	8.18	6.55	0.51	0.86	99	64	60.3	40.20
Total	70.68	57.38	0.08	-	-	-	-	-
Average	6.43	5.22	0.01	0.81	82	60	47	77.88

* Storage bed not in use

known, but there are several factors that must be considered. First, it can be seen that the storage subsystem operates at a fairly low temperature (82°F) as compared to a residential application. The solar energy control system at Scattergood School has been adjusted to operate on solar energy from the rock bed at temperatures down to 65°F in the winter months. This lower control setting allows a more efficient use of solar energy from the rock bed. Second, the higher rock bed utilization in the coldest winter months results in lower rock bed losses. Finally, a continuous low-level natural convection transfer of energy occurs from the rock thermal storage to the building. The natural convection flow results from a chimney effect produced by the combined effects of a tall building, cold internal temperatures, and a hot storage which, by design, is open to the building when the solar system is deenergized.

The 11-month average storage efficiency was 0.81. This indicates that the storage subsystem performed well, especially when the perturbations discussed in the preceding paragraph are considered.

Typical storage performance on a bright day is illustrated in Figure 5.3.2-1. On the day preceding January 9, 1979, insolation levels were relatively low and the storage bin had not been charged to an appreciable degree. As a result, all the available stored solar energy had been used for space heating purposes prior to 0800 hours on January 9 and the storage bin was in a quiescent state. At 0800 hours, the system started up and delivered solar energy directly from the collector array to the conditioned space and to rock storage. At 1000 hours, the space heating demand was satisfied and the system continued to charge storage. Storage charging continued until 1550 hours when solar energy became unavailable and the system shifted back into space heating from the rock thermal storage bed. Approximately two and one-half hours after shutdown, the building temperature and the temperature at the top of the storage bin (T200) reached equilibrium. The direct solar space heating from rock bed storage was deactivated when the rock bed temperature dropped below 65°F. With the loss of controlled solar energy, the

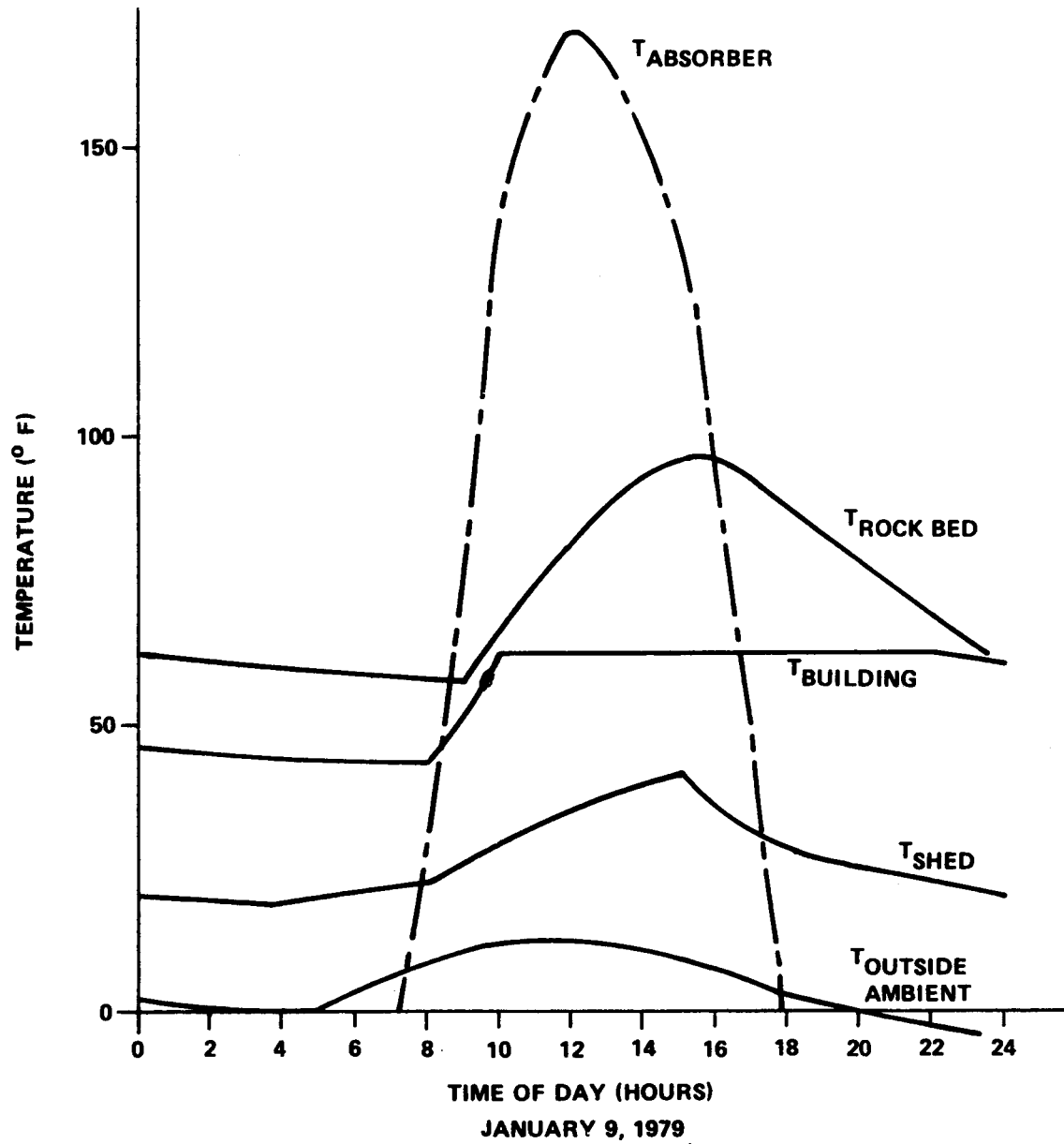

Figure 5.3.2-1 SOLAR SYSTEM AND RECREATIONAL BUILDING TEMPERATURE PROFILES

building temperatures continued to drop until 0600 hours the next morning when auxiliary heaters were utilized to maintain the building temperature at 45°F. The control system for the auxiliary heaters has been overridden to maintain lower temperatures in the building when solar is unavailable. The heaters are only utilized to maintain the building temperatures above 45°F when unoccupied.

Analysis of the heat flow into and out of the shed housing the rock bed indicated that the building and rock bed losses to the shed are contributing to maintain the shed temperatures significantly above outside ambient temperatures. The data for the afternoon of January 9, 1979 (see Figure 5.3.2-1) was used to calculate heat transfer loss coefficients for the building, shed, and rock bed. The results indicate that the rock bed loss coefficient is in the order of 50 Btu/Hr-°F. This heat transfer coefficient is close to the 46 Btu/Hr-°F obtained from the January monthly average rock bed performance, and tends to substantiate the validity of the monthly rock bed loss coefficients. The rock bed loss contribution to the shed temperature stabilization tends to further reduce the rock bed losses.

5.3.3 Hot Water Subsystem

The performance of the hot water subsystem is described by comparing the amount of solar energy supplied to the subsystem with the energy required to satisfy the total hot water load. The energy required to satisfy the total load consists of both solar energy and auxiliary thermal energy. The ratio of solar energy supplied to the load to the total load is defined as the hot water solar fraction. The calculated hot water solar fraction is the indicator of performance for the subsystem because it defines the percentage of the total hot water load supported by solar energy.

The hot water preheat subsystem consists of an air-to-water heat exchanger in the outlet duct of the collector array subsystem. When solar energy is available, a circulation pump, P1, circulates water from the bottom of one of two series connected hot water preheat tanks through the heat exchanger and back to the preheat tanks depositing collected solar energy in those tanks. The preheated solar water is supplied, on demand, to a standard domestic hot water (DHW) tank for distribution to showers located in a locker room adjacent to the Scattergood Recreation Center. If there is insufficient solar energy available to meet the load, auxiliary electric immersion heaters in the DHW tank supply the required energy.

The DHW subsystem at the Scattergood Recreation Center operated continuously throughout the reporting period. Measured monthly values of these performance factors, as applicable, are presented in Table 5.3.3-1. For the 11-month period, June 1978 through April 1979, the solar energy system supplied a total of 21.53 million Btu to the hot water preheat tanks. The total hot water load for this period was 3.91 million Btu and the average monthly solar fraction was 47 percent. The performance of the hot water preheat subsystem was low during the winter months, December 1978 through April 1979. The principal reason for this situation was a low hot water demand coupled with the large solar tank losses that exist during these months. The solar tanks and DHW tanks are located in a building that houses the locker room showers. A continuous infiltration of air from the Recreation Center to the outside is required to eliminate moisture and odors from the locker rooms. This circula-

TABLE 5.3.3-1
HOT WATER SUBSYSTEM PERFORMANCE

Month	Hot Water Load (Million Btu)	Energy Consumed (Million Btu)			Measured Solar Fraction (Percent)
		Solar	Auxiliary Thermal	Auxiliary	
Jun 78	0.34	2.98	0.25	0.25	66
Jul 78	0.35	2.91	0.06	0.06	91
Aug 78	0.17	2.98	0.0	0.0	100
Sep 78	0.12	3.13	0.25	0.25	57
Oct 78	0.65	2.11	1.01	1.01	45
Nov 78	0.42	1.46	0.57	0.57	57
Dec 78	0.41	1.00	0.99	0.99	34
Jan 79	0.19	0.74	0.96	0.96	16
Feb 79	0.50	1.52	1.14	1.14	31
Mar 79	0.48	1.32	1.06	1.06	29
Apr 79	0.28	1.38	0.88	0.88	26
Total	3.91	21.53	7.17	7.17	---
Average	0.36	1.96	0.65	0.65	47

tion enhances the loss from the preheat and DHW tanks. Only during November 1978 and the summer months did the performance of the DHW subsystem measure up to expectations. November performance was increased because of a high demand for hot water that month. The summer performance is as expected due to the high availability of solar energy for that period.

5.3.4 Space Heating Subsystem

The performance of the space heating subsystem is described by comparing the amount of solar energy supplied to the subsystem with the energy required to satisfy the total space heating load. The energy required to satisfy the total load consists of both solar energy and auxiliary thermal energy. The ratio of solar energy supplied to the load to the total load is defined as the heating solar fraction. The calculated heating solar fraction is the indicator of performance for the subsystem because it defines the percentage of the total space heating load supported by solar energy.

The performance of the Scattergood School Recreation Building space heating subsystem is presented in Table 5.3.4-1. For the 11-month period from June 1978 through April 1979, the solar energy system supplied a total of 108.13 million Btu to the space heating load. The total heating load for this period was 132.68 million Btu, and the average monthly solar fraction was 81 percent. The system performance was somewhat low in January 1979, but this is a direct result of significant deviations of weather conditions from the climatic norm. During this month the average outdoor ambient temperature was 12 degrees below normal and the measured insolation in the plane of the collector array was 17 percent below the long-term average. As noted in the Summary and Conclusions section of this report, snowfall (and hence cloudy weather) was much higher than normal during January. The snow cover was so heavy that the collectors were unable to operate for two full weeks even when solar energy was available.

The solar energy system at Scattergood was operated in the grain drying mode in October. This mode operates in the fall to utilize solar energy not required to meet the space heating demand. The grain drying subsystem utilizes the collectors to heat outside air, which is then passed to a propane heater/fan that supplies the remaining energy to reduce the moisture in the grain silo. The indicated solar energy supplied to the grain drying operation was 32.87 million Btu.

TABLE 5.3.4-1
HEATING SUBSYSTEM PERFORMANCE

Month	Space Heating Load (Million Btu)	Energy Consumed (Million Btu)			Measured Solar Fraction (Percent)
		Solar	Auxiliary Thermal	Auxiliary	
Jun 78	5.07	5.07	0.00	0.00	99
Jul 78	3.57	3.57	0.00	0.00	99
Aug 78	3.72	3.72	0.00	0.00	99
Sep 78	3.69	3.69	0.00	0.00	100
Oct 78	4.50*	4.50*	0.00	0.00	100
Nov 78	12.46	11.64	0.82	1.36	93
Dec 78	17.27	14.13	3.14	5.23	82
Jan 79	19.51	11.32	8.19	13.65	58
Feb 79	29.05	21.36	7.69	12.81	74
Mar 79	19.58	16.68	2.90	4.83	85
Apr 79	14.26	12.45	1.81	3.02	87
Total	132.68	108.13*	24.55	40.90	---
Average	12.06	9.83	2.23	3.72	81*

* Grain drying operation utilized 32.87 million Btu of solar energy. Thus, the space heating load was actually 165.55 million Btu, the solar energy consumed 141.00 million Btu and the solar fraction 85 percent when grain drying is included.

The space heating loads indicated during June through September 1978 are due to a damper leak which allowed solar energy to be transferred to the building when the solar energy system was preheating DHW in the summer mode.

The low auxiliary consumption of 24.55 million Btu, as compared to the space heating load of 132.68 million Btu, is due to maintaining the building at low temperatures, the availability of solar energy, the natural convection of energy from the rock bed and the high performance of the collector and rock bed subsystems.

The solar energy control system at Scattergood School only operated during the time that solar energy was available to maintain the gymnasium at 60°F. The control system for the auxiliary heaters is manually overridden to maintain lower temperatures in the gymnasium, and to minimize propane consumption. The heaters are used only when solar energy is unavailable for long periods. The heaters are also used to maintain a minimum temperature of 45°F. In the afternoons and evenings, students using the gym turn the heaters on to maintain a comfortable temperature.

A continuous low-level natural convection transfer of energy exists from the rock thermal storage to the gymnasium. The natural convection flow results from a chimney effect produced by the combined effects of a tall gymnasium, cold internal temperatures, and a hot storage which by design is open to the gymnasium when the solar energy system is deenergized.

Figure 5.3.4-1 illustrates the measured building heat loss coefficient (UA), determined by ratioing the actual measured monthly space heating load to the monthly degree-days multiplied by 24. The UA is relatively stable around 750 Btu/Hr-°F from October 1978 until January 1979. The UA then begins to ramp upward toward a value of 1,400 Btu/Hr-°F. This upward ramp is probably due to increased infiltration in the spring months. The indicated UA for this heating season averaged 950 Btu/Hr-°F, while the UA of the past heating season averaged 815 Btu/Hr-°F (References [10] and [11]). The largest monthly discrepancy between the UA computed from this season and the past season was in April. Variation of the infiltration rates could very well account for this discrepancy.

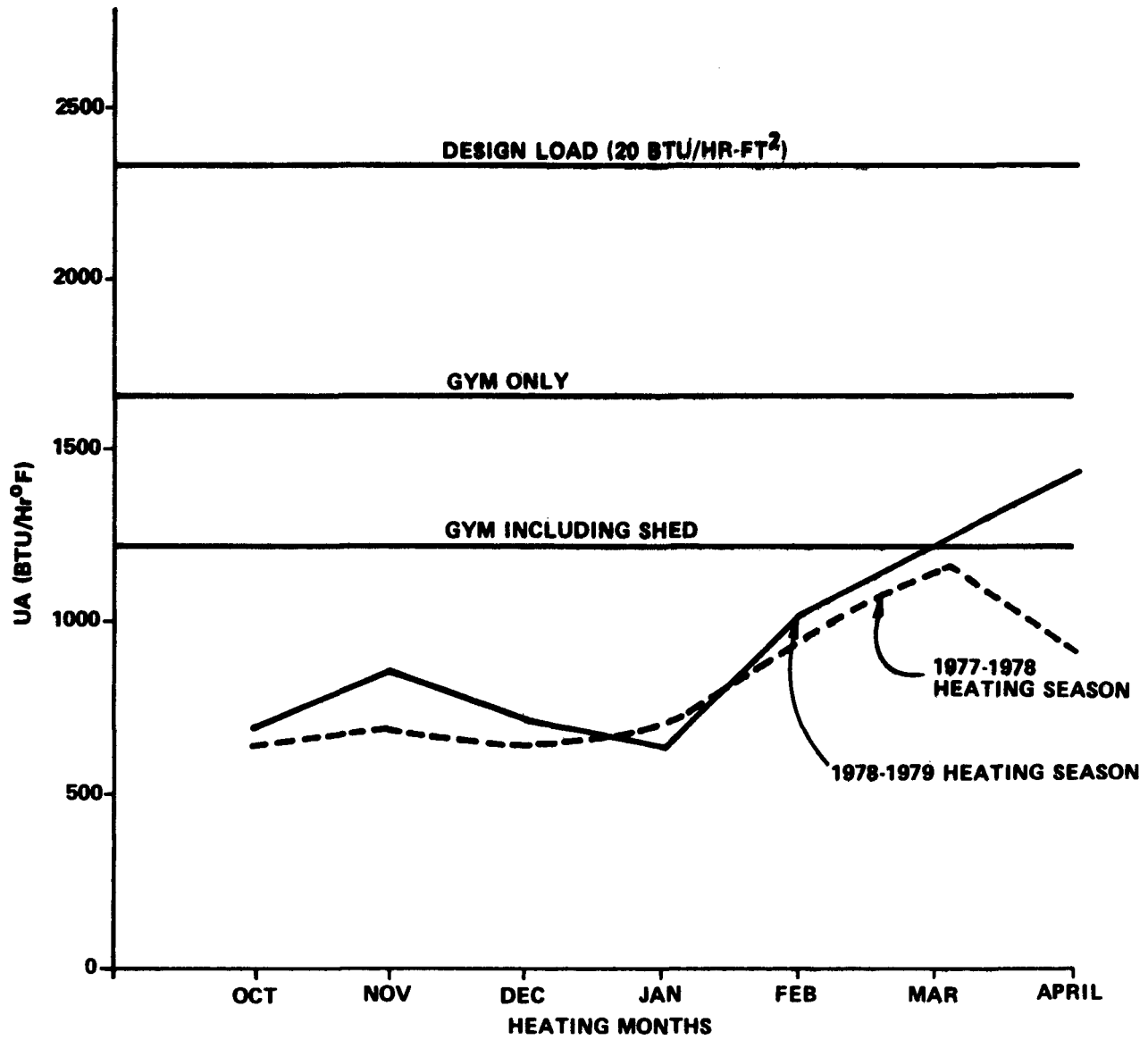

Figure 5.3.4-1. BUILDING HEAT LOSS COEFFICIENT DETERMINATION

A comparison of the measured building heat transfer coefficient, UA, and three predictions of the UA are shown in Figure 5.3.4-1. The system design load, which was utilized to size the solar energy system, was estimated to be 140,000 Btu/Hr. The design load was obtained by using an estimated building heat loss rate of 20 Btu/Hr-Ft² multiplied by the square footage of the building (7,000 Ft²). The building UA estimated from the design load was 2,333/Btu/Hr-°F.

The design load estimation was very conservative because actual building construction utilized significant energy conservation measures, with eight inches of insulation in the ceiling, four inches of insulation in the walls, and a large dead-air-space in the shed that houses the collectors and rock storage. The effect of these measures was to significantly reduce the building heat loss rate. The predicted UA of the building, estimated using a more realistic heating load determined from insulation properties of the building and the area design temperature, was computed to be 1,675 Btu/Hr-°F. When the shed is included, the estimated UA drops to 1,250 Btu/Hr-°F. The difference between the building/shed computed UA and measured UA is due to the contribution of significant solar energy system losses to the shed housing the collectors and to variations in infiltration rates.

During January, the School is on vacation for two weeks between semesters. The Recreation Building was not utilized and the infiltration rates reduced. The significant reduction in UA for the month is evident.

An analysis of the heat transfer interaction between the building, adjoining shed, rock bed and collector duct plenums was performed in order to better understand the Scattergood solar energy system and building interaction. Figure 5.3.4-2 illustrates solar system and Recreational Building temperature profiles for January 9 and 17, 1979 when outside ambient temperatures were very low. The

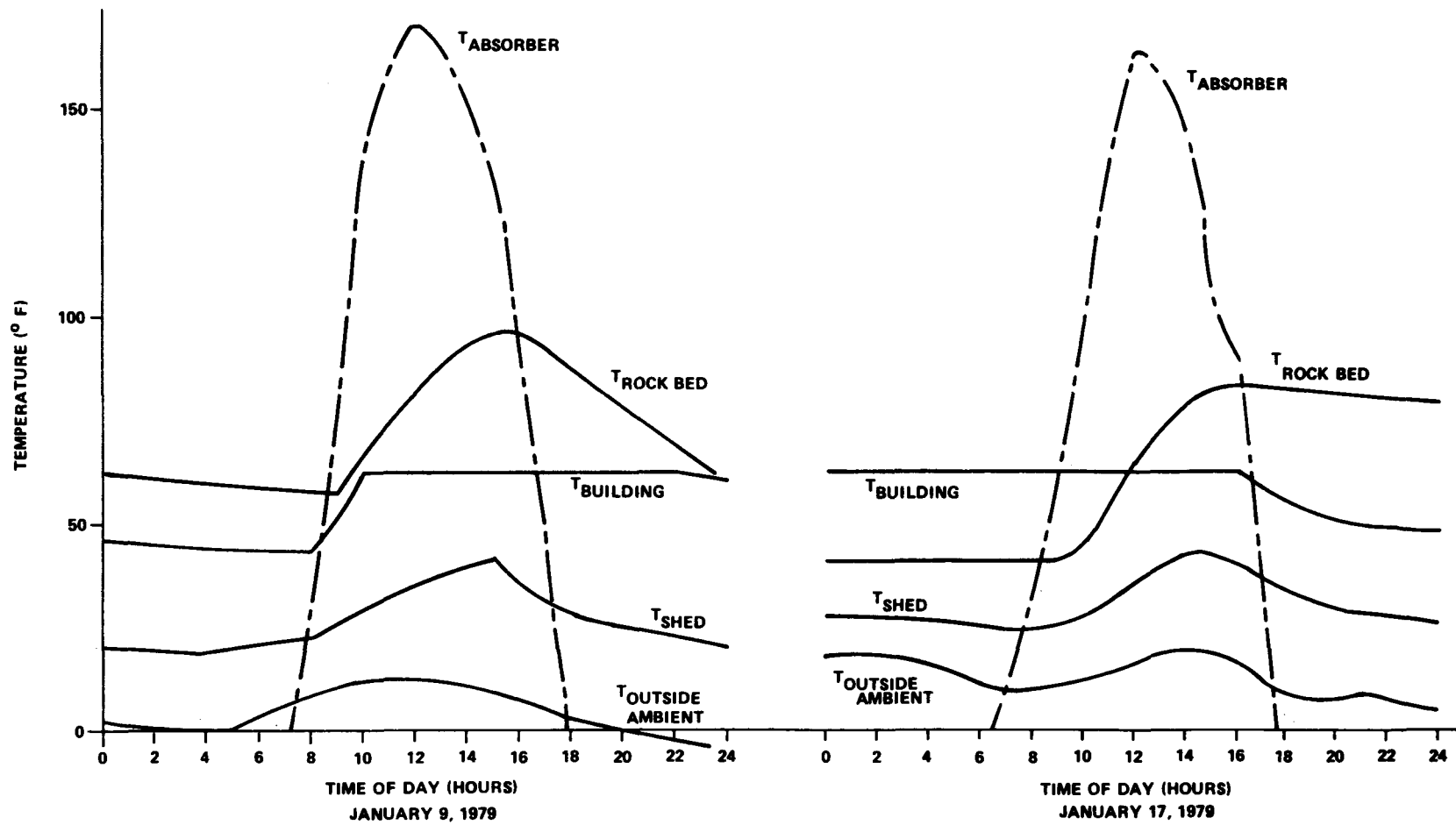

Figure 5.3.4-2. SOLAR SYSTEM AND RECREATIONAL BUILDING TEMPERATURE PROFILES

computed heat transfer coefficients for the entire complex are presented in Figure 5.3.4-3. These coefficients were obtained by using the Data from 23 days in January and February. The building and shed losses were determined during periods of temperature equilibrium at night. The absorber back loss contributions and rock bed losses were determined during and after significant collection periods. Computed temperature profiles were obtained using the heat transfer coefficients and compared to the actual temperature profiles on selected days. The comparison verified that the heat loss coefficients were stable over numerous months.

The analysis revealed that the rock bed losses served to reduce the effective UA of the complex. Approximately 70 percent of the rock bed losses eventually contributed to a reduction of the building UA. The collector back losses were also found to contribute to the building UA reductions as approximately one percent of the total collected energy was transmitted to the shed.

Collector transport losses noted during the heating season apparently did not contribute to the space heating load or UA reduction. No correlation between transport losses and building or shed temperature profiles was observed.

Where: L_S = Shed Heat Loss Coefficient
 L_R = Rock Bed Heat Loss Coefficient
 L_B = Building Heat Loss Coefficient
 L_{BS} = Building to Shed Heat Loss Coefficient
 L_{CB} = Collector Back Heat Loss Coefficient

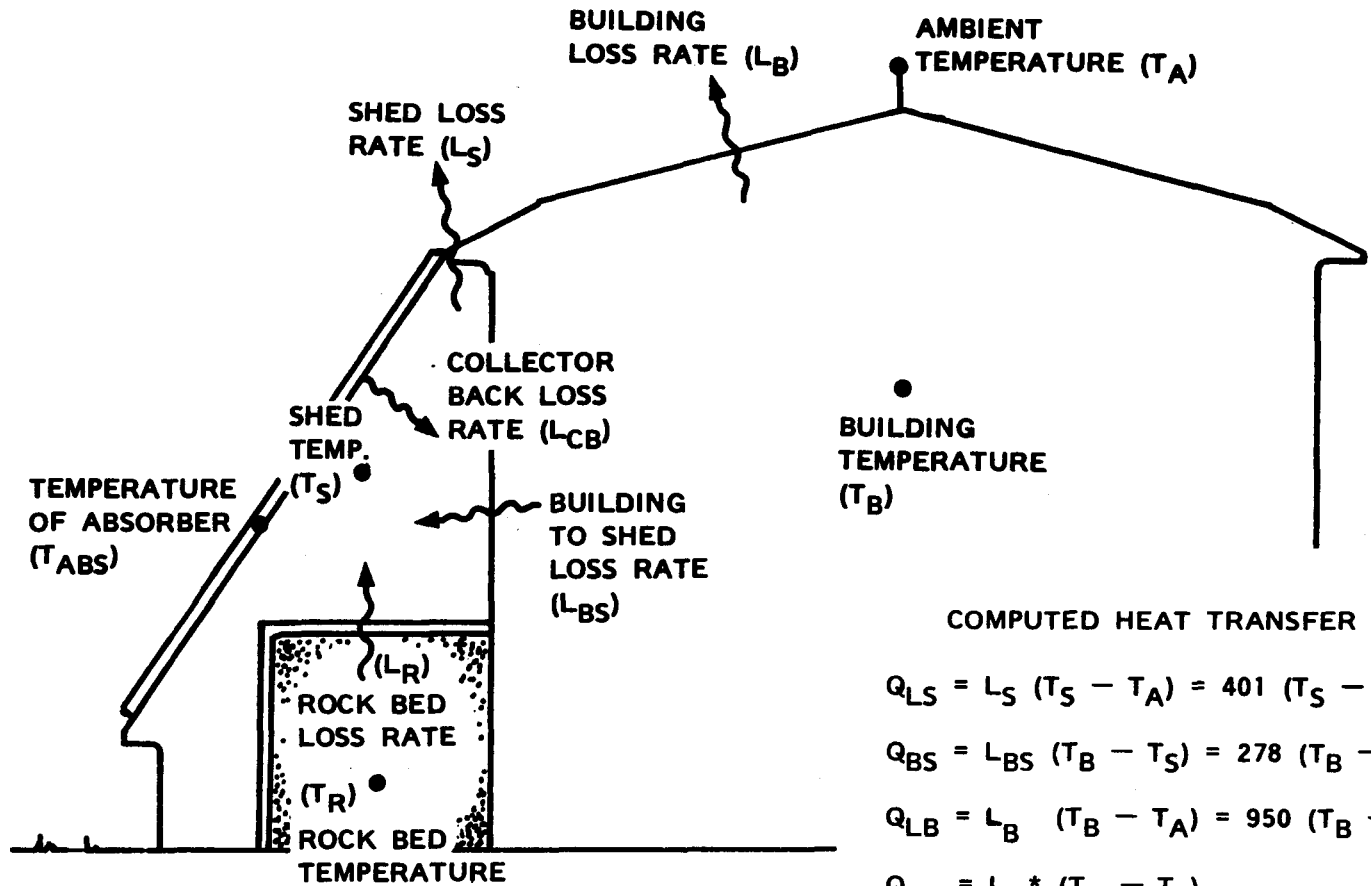

COMPUTED HEAT TRANSFER IS:

$$Q_{LS} = L_S (T_S - T_A) = 401 (T_S - T_A)$$

$$Q_{BS} = L_{BS} (T_B - T_S) = 278 (T_B - T_S)$$

$$Q_{LB} = L_B (T_B - T_A) = 950 (T_B - T_A)$$

$$Q_{LR} = L_R * (T_R - T_S)$$

$$Q_{CB} = L_{CB} (T_{ABS} - T_S) = 25 (T_{ABS} - T_S)$$

* Where L_R is a variable each month (See Table 5.3.2-1)

Figure 5.3.4-3. HEAT LOSS COEFFICIENT DETERMINATION FOR SCATTERGOOD SCHOOL RECREATION CENTER

5.4 Operating Energy

Operating energy for the Scattergood School Recreational Building solar energy system is defined as the energy required to transport solar energy to the point of use. Total operating energy for this system consists of energy collection and storage subsystem operating energy, hot water subsystem operating energy and space heating subsystem operating energy. Operating energy is electrical energy that is used to support the subsystems without affecting their thermal state. Measured monthly values for subsystem operating energy are presented in Table 5.4-1.

Total system operating energy for the Scattergood School is that electrical energy required to operate the blower in the air-handling unit and the domestic hot water heat exchanger circulation pump. This is shown in Figure 3-1 as EP101 and EP301, respectively. Although additional electrical energy is required to operate the five motor-driven dampers shown in Figure 3-1 and the control system for the installation, it is not included in this report. These devices are not monitored for power consumption and the power they consume is inconsequential when compared to the fan and pump motors.

The collector operating energy was allocated to each subsystem by ratioing the pressure drop of each subsystem to the total pressure drop of the fan during each known mode of operation. These measurements were obtained during checkout of the system in July 1977.

For the overall period covered by this report, a total of 9.82 million Btu of operating energy was consumed. During the same time a total of 162.51 million Btu of solar energy was supplied to the space heating, hot water and grain drying loads. Therefore, for every one million Btu of solar energy delivered to the load, 0.06 million Btu (or 16.97 kwh) of electrical operating energy was expended.

The low space heating operating expense is the result of two factors. First, a continuous low-level natural convection transfer of energy exists from the rock thermal storage to the gymnasium. The natural convection flow results

TABLE 5.4-1
OPERATING ENERGY

Month	ECSS Operating Energy (Million Btu)	Operating Energy-Heating (Million Btu)	Operating Energy-Hot Water (Million Btu)	Total System Operating Energy (Million Btu)
Jun 78	0.39	0.08	0.24	0.71
Jul 78	0.43	0.03	0.25	0.71
Aug 78	0.45	0.02	0.27	0.33
Sep 78	0.38	0.02	0.23	0.64
Oct 78	0.81	0.79*	0.32	1.92*
Nov 78	0.39	0.09	0.16	0.64
Dec 78	0.34	0.34	0.16	0.83
Jan 79	0.25	0.25	0.14	0.64
Feb 79	0.55	0.52	0.25	1.32
Mar 79	0.45	0.31	0.19	0.94
Apr 79	0.43	0.14	0.17	0.74
Total	4.87	2.59	2.38	9.82
Average	0.44	0.24	0.22	0.89

* Grain drying operating energy included.

from a chimney effect produced by the combined effects of a tall gymnasium, cold internal temperatures, and a hot storage which, by design, is open to the gymnasium when the solar system is deenergized. Second, the gymnasium was controlled at very low temperatures which reduced the requirements for controlled energy transfer using the circulation fan, thus reducing the operating expense.

5.5 Energy Savings

Solar energy system savings are realized whenever energy provided by the solar energy system is used to meet system demands which would otherwise be met by auxiliary energy sources. The operating energy required to provide solar energy to the load subsystem is subtracted from the solar energy contribution, and the resulting energy savings are adjusted to reflect the coefficient of performance (COP) of the auxiliary source being supplanted by solar energy.

The solar energy delivered to the space heating load during June, July, August and the early portion of September, when no space heating demand existed, was caused by a 10-percent leak in motorized damper MD-2 (Figure 3-1). Because of this leak, the building temperature was maintained at 79°F. The resulting pseudo energy savings indicated by this condition should be ignored.

The auxiliary space heating source at Scattergood School consists of two 250K-Btu propane gas heaters located inside the building. These units are assumed to be 60 percent efficient.

The domestic hot water auxiliary is a standard electric immersion heater in the domestic hot water tank. The efficiency of an electric heater is assumed to be 100 percent.

Fossil and electrical energy savings for June 1978 through April 1979 are presented in Table 5.5-1. For this time period, the average gross monthly savings were 21.54 million Btu. After the total system operating energy was deducted, the average net monthly savings were 20.64 million Btu. The solar energy system saved 254.63 million Btu of fossil energy, which is equivalent to 2,783 gallons of propane. The cost of propane at West Branch, Iowa is \$0.45 per gallon which results in an indicated cost savings of \$1,252.28. The electrical energy cost necessary to obtain these savings was 1,774 kilowatt hours. The cost of electricity at West Branch, Iowa is \$0.05 per kwh. Thus, the electrical cost was \$88.70. The net solar system cost savings were \$1,163.58.

TABLE 5.5-1
ENERGY SAVINGS

Month	Energy Savings (Million Btu)			Operating Energy (Million Btu)	Electrical Cost		Fossil Savings (Million Btu)	Net Fossil Equivalent Savings (Million Btu)
	Space Heating	**	Hot Water		(Million Btu)	(kwh)		
						(Million Btu)		
Jun 78	8.44	0.0	0.34	0.71	0.37	108	8.44	7.21
Jul 78	5.93	0.0	0.37	0.71	0.34	100	5.93	4.80
Aug 78	6.20	0.0	0.18	0.73	0.55	161	6.20	4.37
Sep 78	6.15	0.0	0.14	0.64	0.50	146	6.15	4.49
Oct 78	62.27*	3.58	0.92	1.92	1.00	293	65.85	62.52
Nov 78	19.39	2.58	0.46	0.64	0.18	53	21.97	21.37
Dec 78	25.54	2.43	0.31	0.83	0.52	152	27.97	26.24
Jan 79	18.86	1.62	0.16	0.64	0.48	140	20.48	18.88
Feb 79	35.61	2.70	0.45	1.32	0.87	255	38.31	35.41
Mar 79	27.90	3.08	0.26	0.94	0.68	199	30.98	28.71
Apr 79	20.70	1.65	0.17	0.79	0.57	167	22.35	20.09
Total	236.99*	17.64	3.76	9.87	6.06	1,774	254.63	234.09
Average	21.54*	1.60	0.34	0.90	0.55	161	23.15	21.28

* Grain drying included.

** UA reduction effect = $[0.7 \times (\text{All rock bed losses}) + 0.01 \times (\text{Collected energy})] / 0.6$

Elimination of the pseudo energy savings in June, July, August and half of September results in a net solar energy savings of 230.99 million Btu of fossil energy or, equivalently, 2,525 gallons of propane. At \$0.45 per gallon, the gross cost savings would be \$1,136.25 and the net cost savings were \$1,046.75.

Blank Page

6. REFERENCES

1. U. S. Department of Energy, National Solar Data Network, Prepared under Contract Number EG-77-C-01-4049, by IBM Corporation, December, 1977.
2. J. T. Smok, V. S. Sohoni, J. M. Nash, "Processing of Instrumented Data for the National Solar Heating and Cooling Demonstration Program," Conference on Performance Monitoring Techniques for Evaluation of Solar Heating and Cooling Systems, Washington, DC, April, 1978.
3. E. Streed, et. al., Thermal Data Requirements and Performance Evaluation Procedures for the National Solar Heating and Cooling Demonstration Program, NBSIR 76-1137, National Bureau of Standards, Washington, August, 1976.
4. Mears, J. C., Reference Monthly Environmental Data for Systems in the National Solar Data Network. Department of Energy report SOLAR/0019-79/36. Washington, DC, 1979.
5. ASHRAE Standard 93-77, Methods of Testing to Determine the Thermal Performance of Solar Collectors, The American Society of Heating, Refrigeration and Air Conditioning Engineers, Inc., New York, NY, 1977.
6. ASHRAE Standard 94-77, Methods of Testing Thermal Storage Devices Based on Thermal Performance, The American Society of Heating, Refrigeration and Air Conditioning Engineerings, Inc., New York, NY, 1977.
7. McCumber, W. H. Jr., "Collector Array Performance for Instrumented Sites of the National Solar Heating and Cooling Demonstration Program," to be published and distributed at the 1979 Solar Update Conference.
8. R. L. Oonk, G.O.G. Löf, L. E. Shan, B. E. Cole-Appel, "A Method of Comparing Flat-Plate Air and Liquid Solar Collectors for Use in Space Heating Applications," in K. W. Boer, ed., Sharing the Sun, Solar Technology in the Seventies, Vol. 2: Solar Collectors, Cape Canaveral, FL: American Section of the International Solar Energy Society, 1976, pp. 83-93.
9. Dr. Conrad F. Heins, Solar Heating System for Recreation Building at Scattergood School, DOE/NASA Report CR-150553, January 1978. Prepared under Contract Number EX-76-C-01-2386.
- 10.* Kenneth L. Shenfish, Solar Energy System Performance Evaluation - Scattergood School Recreation Center, SOLAR/2003-78/14, July 1978.

- 11.* Kenneth L. Shenfish, "Thermal Performance of the Scattergood School Solar Energy System," paper presented at the Department of Energy's Solar Update, Regional Conference, Atlanta, 12-14, 1978, SOLAR/2003-78/23.
12. "Solar Project Description for Scattergood School," October 1977.
- 13.* Monthly Performance Reports, Scattergood School, SOLAR/2003-78/06 through SOLAR/2003-79/04 (June 1978 through April 1979), Department of Energy, Washington.

* Copies of these reports may be obtained from Technical Information Center, P. O. Box 62, Oak Ridge, Tennessee 37830.

APPENDIX A

DEFINITION OF PERFORMANCE FACTORS AND SOLAR TERMS

COLLECTOR ARRAY PERFORMANCE

The collector array performance is characterized by the amount of solar energy collected with respect to the energy available to be collected.

- INCIDENT SOLAR ENERGY (SEA) is the total insolation available on the gross collector array area. This is the area of the collector array energy-receiving aperture, including the framework which is an integral part of the collector structure.
- OPERATIONAL INCIDENT ENERGY (SEOP) is the amount of solar energy incident on the collector array during the time that the collector loop is active (attempting to collect energy).
- COLLECTED SOLAR ENERGY (SECA) is the thermal energy removed from the collector array by the energy transport medium.
- COLLECTOR ARRAY EFFICIENCY (CAREF) is the ratio of the energy collected to the total solar energy incident on the collector array. It should be emphasized that this efficiency factor is for the collector array, and available energy includes the energy incident on the array when the collector loop is inactive. This efficiency must not be confused with the more common collector efficiency figures which are determined from instantaneous test data obtained during steady state operation of a single collector unit. These efficiency figures are often provided by collector manufacturers or presented in technical journals to characterize the functional capability of a particular collector design. In general, the collector panel maximum efficiency factor will be significantly higher than the collector array efficiency reported here.

STORAGE PERFORMANCE

The storage performance is characterized by the relationships among the energy delivered to storage, removed from storage, and the subsequent change in the amount of stored energy.

- ENERGY TO STORAGE (STEI) is the amount of energy, both solar and auxiliary, delivered to the primary storage medium.
- ENERGY FROM STORAGE (STEO) is the amount of energy extracted by the load subsystems from the primary storage medium.
- CHANGE IN STORED ENERGY (STECH) is the difference in the estimated stored energy during the specified reporting period, as indicated by the relative temperature of the storage medium (either positive or negative value).
- STORAGE AVERAGE TEMPERATURE (TST) is the mass-weighted average temperature of the primary storage medium.
- STORAGE EFFICIENCY (STEFF) is the ratio of the sum of the energy removed from storage and the change in stored energy to the energy delivered to storage.

ENERGY COLLECTION AND STORAGE SUBSYSTEM

The Energy Collection and Storage Subsystem (ECSS) is composed of the collector array, the primary storage medium, the transport loops between these, and other components in the system design which are necessary to mechanize the collector and storage equipment.

- INCIDENT SOLAR ENERGY (SEA) is the total insolation available on the gross collector array area. This is the area of the collector array energy-receiving aperture, including the framework which is an integral part of the collector structure.
- AMBIENT TEMPERATURE (TA) is the average temperature of the outdoor environment at the site.
- ENERGY TO LOADS (SEL) is the total thermal energy transported from the ECSS to all load subsystems.
- AUXILIARY THERMAL ENERGY TO ECSS (CSAUX) is the total auxiliary supplied to the ECSS, including auxiliary energy added to the storage tank, heating devices on the collectors for freeze-protection, etc.
- ECSS OPERATING ENERGY (CSOPE) is the critical operating energy required to support the ECSS heat transfer loops.

HOT WATER SUBSYSTEM

The hot water subsystem is characterized by a complete accounting of the energy flow into and from the subsystem, as well as an accounting of internal energy. The energy into the subsystem is composed of auxiliary fossil fuel, and electrical auxiliary thermal energy, and the operating energy for the subsystem. In addition, the solar energy supplied to the subsystem, along with solar fraction is tabulated. The load of the subsystem is tabulated and used to compute the estimated electrical and fossil fuel savings of the subsystem. The load of the subsystem is further identified by tabulating the supply water temperature, and the outlet hot water temperature, and the total hot water consumption.

- HOT WATER LOAD (HWL) is the amount of energy required to heat the amount of hot water demanded at the site from the incoming temperature to the desired outlet temperature.
- SOLAR FRACTION OF LOAD (HWSFR) is the percentage of the load demand which is supported by solar energy.
- SOLAR ENERGY USED (HWSE) is the amount of solar energy supplied to the hot water subsystem.
- OPERATING ENERGY (HWOPE) is the amount of electrical energy required to support the subsystem, (e.g., fans, pumps, etc.) and which is not intended to affect directly the thermal state of the subsystem.
- AUXILIARY THERMAL USED (HWAT) is the amount of energy supplied to the major components of the subsystem in the form of thermal energy in a heat transfer fluid, or its equivalent. This term also includes the converted electrical and fossil fuel energy supplied to the subsystem.

- AUXILIARY ELECTRICAL FUEL (HWAEL) is the amount of electrical energy supplied directly to the subsystem.
- ELECTRICAL ENERGY SAVINGS (HWSVE) is the estimated difference between the electrical energy requirements of an alternative conventional system (carrying the full load) and the actual electrical energy required by the subsystem.
- SUPPLY WATER TEMPERATURE (TSW) is the average inlet temperature of the water supplied to the subsystem.
- AVERAGE HOT WATER TEMPERATURE (THW) is the average temperature of the outlet water as it is supplied from the subsystem to the load.
- HOT WATER USED (HWCSM) is the volume of water used.

SPACE HEATING SUBSYSTEM

The space heating subsystem is characterized by performance factors accounting for the complete energy flow to and from the subsystem. The average building temperature and the average ambient temperature are tabulated to indicate the relative performance of the subsystem in satisfying the space heating load and in controlling the temperature of the conditioned space.

- SPACE HEATING LOAD (HL) is the sensible energy added to the air in the building.
- SOLAR FRACTION OF LOAD (HSFR) is the fraction of the sensible energy added to the air in the building derived from the solar energy system.
- SOLAR ENERGY USED (HSE) is the amount of solar energy supplied to the space heating subsystem.
- OPERATING ENERGY (HOPE) is the amount of electrical energy required to support the subsystem, (e.g., fans, pumps, etc.) and which is not intended to affect directly the thermal state of the subsystem.
- AUXILIARY THERMAL USED (HAT) is the amount of energy supplied to the major components of the subsystem in the form of thermal energy in a heat transfer fluid or its equivalent. This term also includes the converted electrical and fossil fuel energy supplied to the subsystem.
- AUXILIARY ELECTRICAL FUEL (HAE) is the amount of electrical energy supplied directly to the subsystem.
- ELECTRICAL ENERGY SAVINGS (HSVE) is the estimated difference between the electrical energy requirements of an alternative conventional system (carrying the full load) and the actual electrical energy required by the subsystem.

- BUILDING TEMPERATURE (TB) is the average heated space dry bulb temperature.
- AMBIENT TEMPERATURE (TA) is the average ambient dry bulb temperature at the site.

ENVIRONMENTAL SUMMARY

The environmental summary is a collection of the weather data which is generally instrumented at each site in the program. It is tabulated in this data report for two purposes--as a measure of the conditions prevalent during the operation of the system at the site, and as an historical record of weather data for the vicinity of the site.

- TOTAL INSOLATION (SE) is accumulated total solar energy incident upon the gross collector array measured at the site.
- AMBIENT TEMPERATURE (TA) is the average temperature of the environment at the site.
- WIND DIRECTION (WDIR) is the average direction of the prevailing wind.
- WIND SPEED (WIND) is the average wind speed measured at the site.
- DAYTIME AMBIENT TEMPERATURE (TDA) is the temperature during the period from three hours before solar noon to three hours after solar noon.

APPENDIX B

SOLAR ENERGY SYSTEM PERFORMANCE EQUATIONS FOR SCATTERGOOD SCHOOL

1. INTRODUCTION

Solar energy system performance is evaluated by performing energy balance calculations on the system and its major subsystems. These calculations are based on physical measurement data taken from each subsystem every 320 seconds. This data is then numerically combined to determine the hourly, daily, and monthly performance of the system. This appendix describes the general computational methods and the specific energy balance equations used for this evaluation.

Data samples from the system measurements are numerically integrated to provide discrete approximations of the continuous functions which characterize the system's dynamic behavior. This numerical integration is performed by summation of the product of the measured rate of the appropriate performance parameters and the sampling interval over the total time period of interest.

There are several general forms of numerical integration equations which are applied to each site. These general forms are exemplified as follows: The total solar energy available to the collector array is given by,

$$\text{SOLAR ENERGY AVAILABLE} = (1/60) \Sigma [I001 \times \text{AREA}] \times \Delta\tau$$

Where I001 is the solar radiation measurement provided by the pyranometer in Btu/ft²-hr, AREA is the area of the collector array in square feet, $\Delta\tau$ is the sampling interval in minutes, and the factor (1/60) is included to correct the solar radiation "rate" to the proper units of time.

Similarly, the energy flow within a system is given typically by

$$\text{COLLECTED SOLAR ENERGY} = \Sigma [M100 \times \Delta H] \times \Delta t$$

where M100 is the mass flow rate of the heat transfer fluid in lb_m/min and ΔH is the enthalpy change, in Btu/lb_m , of the fluid as it passes through the heat exchanging component.

For a liquid system ΔH is generally given by

$$\Delta H = \bar{C}_p \Delta T$$

where \bar{C}_p is the average specific heat, in $\text{Btu}/(\text{lb}_m \cdot ^\circ\text{F})$, of the heat transfer fluid and ΔT , in $^\circ\text{F}$, is the temperature differential across the heat exchanging component.

For an air system ΔH is generally given by

$$\Delta H = H_a(T_{\text{out}}) - H_a(T_{\text{in}})$$

where $H_a(T)$ is the enthalpy, in Btu/lb_m , of the transport air evaluated at the inlet and outlet temperatures of the heat exchanging component.

$H_a(T)$ can have various forms, depending on whether or not the humidity ratio of the transport air remains constant as it passes through the heat exchanging component.

For electrical power, a general example is,

$$\text{ECSS OPERATING ENERGY} = (3413/60) \sum [\text{EP100}] \times \Delta\tau$$

Where EP100 is the power required by electrical equipment in kilowatts and the two factors (1/60) and 3413 correct the data to Btu/min.

These equations are comparable to those specified in "Thermal Data Requirements and Performance Evaluation Procedures for the National Solar Heating and Cooling Demonstration Program." This document, given in the list of references, was prepared by an interagency committee of the Government, and presents guidelines for thermal performance evaluation.

Performance factors are computed for each hour of the day. Each numerical integration process, therefore, is performed over a period of one hour. Since long-term performance data is desired, it is necessary to build these hourly performance factors to daily values. This is accomplished, for energy parameters, by summing the 24 hourly values. For temperatures, the hourly values are averaged. Certain special factors, such as efficiencies, require appropriate handling to properly weight each hourly sample for the daily value computation. Similar procedures are required to convert daily values to monthly values.

EQUATIONS USED IN MONTHLY PERFORMANCE REPORT

NOTE: - MEASUREMENT NUMBERS REFERENCE SYSTEM SCHEMATIC FIGURE 3-1

SITE SUMMARY REPORT

INCIDENT SOLAR ENERGY (BTU)

$$SEA = (1/60) \sum [I001 \times AREA] \times \Delta\tau$$

INCIDENT SOLAR ENERGY PER UNIT AREA (BTU/SQ FT)

$$SE = (1/60) \sum I001 \times \Delta\tau$$

HUMIDITY RATIO FUNCTION (BTU/LBM-°F)

$$HRF = 0.24 + 0.44 \times HR$$

WHERE 0.24 IS THE SPECIFIC HEAT AND HR IS THE HUMIDITY RATIO OF THE TRANSPORT AIR. THIS FUNCTION IS USED WHENEVER THE HUMIDITY RATIO WILL REMAIN CONSTANT AS THE TRANSPORT AIR FLOWS THROUGH A HEAT EXCHANGING DEVICE.

COLLECTED SOLAR ENERGY (BTU)

$$SECA = \sum [M100 \times HRF \times (T150 - T100)] \times \Delta\tau$$

COLLECTED SOLAR ENERGY PER UNIT AREA (BTU/SQ FT)

$$SEC = \sum [M100 \times HRF \times (T150 - T100)/AREA] \times \Delta\tau$$

AVERAGE AMBIENT TEMPERATURE (°F)

$$TA = (1/60) \sum T001 \times \Delta\tau$$

AVERAGE BUILDING TEMPERATURE (°F)

$$TB = (1/60) \sum T600 \times \Delta\tau$$

ECSS SOLAR CONVERSION EFFICIENCY

$$CSCEF = \text{SOLAR ENERGY TO LOAD/INCIDENT SOLAR ENERGY}$$

ECSS OPERATING ENERGY (BTU)

$$\text{CSOPE} = \sum 56.8833 \times \text{ALPHA} \times (\text{EP101} - \text{FP301}^*) \times \Delta\tau$$

WHENEVER COLLECTORS ARE OPERATING

ALPHA IS THE AMOUNT OF FAN POWER APPORTIONED TO THE ECSS DETERMINED FROM PRESSURE DROP MEASUREMENTS FOR EACH COLLECTION OR STORAGE MODE

TOTAL SYSTEM OPERATING ENERGY (BTU)

$$\text{SYSOPE} = \text{ECSS OPERATING ENERGY} + \text{HEATING OPERATING ENERGY} + \text{HOT WATER OPERATING ENERGY}$$

TOTAL ENERGY CONSUMED (BTU)

$$\text{TECSM} = \text{AUXILIARY ENERGY} + \text{SYSTEM OPERATING ENERGY} + \text{SOLAR ENERGY COLLECTED}$$

LOAD SUBSYSTEM SUMMARY (BTU)

HEATING LOAD

$$\text{HL} = \text{HEATING SOLAR ENERGY} + \text{HEATING AUXILIARY THERMAL ENERGY}$$

HOT WATER LOAD

$$\text{HWL} = \text{HOT WATER SOLAR ENERGY} + \text{HOT WATER AUXILIARY THERMAL ENERGY}$$

HEATING AUXILIARY FOSSIL FUEL (BTU)

$$\text{HAF} = \text{HF} \times (\text{F400} - \text{LF400})$$

WHERE HF IS THE HEAT CONTENT OF THE FOSSIL FUEL

TOTAL AUXILIARY FOSSIL FUEL (BTU)

$$\text{AXF} = \text{HEATING AUXILIARY FOSSIL FUEL}$$

HOT WATER ELECTRICAL SAVINGS (BTU)

$$\text{HWSVE} = \text{HOT WATER SOLAR ENERGY IN TANK} - \text{HOT WATER OPERATING ENERGY}$$

HEATING ELECTRICAL SAVINGS (BTU)

$$\text{HSVE} = - \text{HEATING OPERATING ENERGY}$$

TOTAL ELECTRICAL SAVINGS (BTU)

$$\text{TSVE} = \text{HEATING ELECTRICAL SAVINGS} + \text{HOT WATER ELECTRICAL SAVINGS}$$

* EP101 POWER MEASUREMENT IS THE SUM OF COLLECTOR FAN POWER AND DHW HEAT EXCHANGER PUMP POWER (SEPARATED JUNE 1979). FP301 IS AN ESTIMATE OF THE DHW HEAT EXCHANGER PUMP POWER (ZERO AFTER MAY 1979).

HEATING FOSSIL SAVINGS (BTU)

$$\text{HSVF} = (\text{HEATING LOAD}/\text{HEFF}) - \text{HEATING AUXILIARY FOSSIL}$$

WHERE HEFF IS THE AUXILIARY CONVERSION EFFICIENCY

SYSTEM LOAD (BTU)

$$\text{SYSL} = \text{HEATING LOAD} + \text{HOT WATER LOAD}$$

HEATING SOLAR FRACTION (PERCENT)

$$\text{HSFR} = 100 \times (\text{HEATING SOLAR ENERGY}/\text{HEATING LOAD})$$

HOT WATER SOLAR FRACTION (PERCENT)

$$\text{HWSFR} = 100 \times (\text{HOT WATER SOLAR ENERGY}/\text{HOT WATER LOAD})$$

SYSTEM SOLAR FRACTION (PERCENT)

$$\text{SFR} = 100 \times (\text{HOT WATER LOAD} \times \text{HOT WATER SOLAR FRACTION} + \text{HEATING LOAD} \times \text{HEATING SOLAR FRACTION})/\text{SYSTEM LOAD}$$

ENTHALPHY FUNCTION (BTU/LBM)

$$\text{HWD}(T_2, T_1) = \int_{T_1}^{T_2} c_p(T) dT$$

THIS FUNCTION COMPUTES THE ENTHALPY CHANGE OF WATER AS IT PASSES THROUGH A HEAT EXCHANGING DEVICE.

HOT WATER SOLAR ENERGY (BTU)

$$\text{HWSE} = \Sigma [\text{M302} \times \text{HWD}(T302, T352)] \times \Delta\tau$$

HOT WATER SOLAR ENERGY IN DHW TANK (BTU)

$$\text{HWSE1} = \Sigma [\text{M306} \times \text{HWD}(T306, T305)] \times \Delta\tau$$

M306 BECOMES M305, T306 BECOMES T357 AFTER MAY 1979

HEATING SOLAR ENERGY (BTU)

$$HSE = \Sigma [M400 \times HWD(T402, T452)] \times \Delta\tau$$

WHENEVER IN HEATING MODE

TOTAL SOLAR ENERGY TO LOADS

$$SEL = \text{HOT WATER SOLAR ENERGY} + \text{HEATING SOLAR ENERGY (BTU)}$$

OPERATING ENERGY (BTU):

HOT WATER OPERATING ENERGY

$$HWOPE = \Sigma [56.8833 \times (FP301* + BETA \times (EP101 - FP301*))] \times \Delta\tau$$

WHENEVER IN HOT WATER HEATING MODES, BETA IS THE AMOUNT OF FAN POWER APPORTIONED TO THE HOT WATER SUBSYSTEM

HEATING OPERATING ENERGY

$$HOPE = \Sigma [56.8833 \times (K1 \times EP402 + GAMMA \times (EP101 - FP301))] \times \Delta\tau$$

FOR SOLAR HEATING MODES [K1 = 1]

GAMMA IS THE FRACTION OF FAN POWER APPORTIONED TO THE SPACE HEATING SUBSYSTEM DETERMINED FROM PRESSURE DROP MEASUREMENT FOR EACH MODE

TOTAL OPERATING ENERGY (BTU)

$$SYSOPE = \text{ECSS OPERATING ENERGY} + \text{HEATING OPERATING ENERGY} + \text{COOLING OPERATING ENERGY}$$

HOT WATER AUXILIARY THERMAL ENERGY (BTU)

$$HWAT = \Sigma [56.8833 \times EP300] \times \Delta\tau$$

HEATING AUXILIARY THERMAL ENERGY (BTU)

$$HAT = HF \times HEFF \times (F400 - LF400)$$

WHERE HF IS THE HEAT CONTENT OF THE FOSSIL FUEL AND HEFF IS THE CONVERSION EFFICIENCY

* EP101 POWER MEASUREMENT IS THE SUM OF COLLECTOR FAN POWER AND DHW HEAT EXCHANGER PUMP POWER (SEPARATED JUNE 1979). FP301 IS AN ESTIMATE OF THE DHW HEAT EXCHANGER PUMP POWER (ZERO AFTER MAY 1979).

TOTAL AUXILIARY THERMAL ENERGY (BTU)

AXT = HEATING AUXILIARY THERMAL ENERGY

HOT WATER AUXILIARY ELECTRIC FUEL (BTU)

HAC = $\Sigma [56.8833 \times EP300] \times \Delta\tau$

TOTAL AUXILIARY ELECTRIC FUEL (BTU)

AXT = HOT WATER AUXILIARY ELECTRIC FUEL

TOTAL FOSSIL SAVINGS (BTU)

TSVF = HEATING FOSSIL SAVINGS

SYSTEM PERFORMANCE FACTOR

SYSPPF = SYSTEM LOAD / [(AUXILIARY FOSSIL FUEL + 3.33 x (AUXILIARY ELECTRIC FUEL + SYSTEM OPERATING ENERGY))]

OPERATIONAL INCIDENT ENERGY (BTU)

SEOP = (1/60) $\Sigma [1001 \times AREA] \times \Delta\tau$

COLLECTOR ARRAY EFFICIENCY

CAREF = SOLAR ENERGY COLLECTED / INCIDENT SOLAR ENERGY

ENERGY TO STORAGE (BTU)

STEI = $\Sigma [M100 \times (T151 - T101) \times HRF] \times \Delta\tau$

ENERGY FROM STORAGE (BTU)

STEO = $\Sigma [M400 \times (T151 - T101) \times HRF] \times \Delta\tau$

M400 BECOMES M200 AFTER MAY 1979

CHANGE IN STORED ENERGY (BTU)

STECH = STORAGE CAPACITY x [HEAT CONTENT PREVIOUS SCAN - HEAT CONTENT PRESENT SCAN] x [1 - VOID FRACTION]

WHERE STORAGE CAPACITY IS THE ACTIVE VOLUME IN TANK AND VOID FRACTION IS RATIO OF VOLUME OF AIR TO VOLUME OF ROCK

STORAGE AVERAGE TEMP (°F)

$$TST = (1/60) \sum [(T200 + T201 + T202) / 3] \times \Delta\tau$$

STORAGE EFFICIENCY

$$STEFF = (\text{CHANGE IN STORED ENERGY} + \text{ENERGY FROM STORAGE}) / \text{ENERGY TO STORAGE}$$

ECSS SOLAR CONVERSION EFFICIENCY

$$CSCEF = \text{SOLAR ENERGY TO LOADS} / \text{INCIDENT SOLAR ENERGY}$$

SUPPLY WATER TEMP (°F)

$$TSW = (1/60) \sum [T305 \times M306] \times \Delta\tau / \sum [M306] \times \Delta\tau$$

M306 BECOMES M305 AFTER MAY 1979

HOT WATER USED (GALLONS)

$$THW = \sum [W306] \times \Delta\tau$$

M306 BECOMES W305 AFTER MAY 1979

DAYTIME AMBIENT TEMP (°F)

$$TDA = (1/360) \sum [T001] \times \Delta\tau$$

± THREE HOURS FROM SOLAR NOON

RELATIVE HUMIDITY (PERCENT)

$$RELH = (1/60) \sum RH001 \times \Delta\tau$$

RH001 OBTAINED FROM CORROSION MONITOR INSTRUMENTATION AFTER MAY 1979

WIND DIRECTION (DEGREES)

$$WDIR = (1/60) \sum [D001] \times \Delta\tau$$

WIND SPEED (M.P.H.)

$$WIND = (1/60) \sum [V001] \times \Delta\tau$$

EQUATIONS USED IN GRAIN DRYING OPTION

GRAIN DRYING COMPUTATIONS LOCATED IN EXTRA LOAD REPORT OF THE MONTHLY REPORT

GRAIN DRYING LOAD (BTU)

$$GDHL = \Sigma [M410 * HRF * (T460 - T410)] \times \Delta\tau$$

GRAIN DRYING SOLAR ENERGY (BTU)

$$BDHSE = \Sigma [M410 * HRF * (T460 - T410)] \times \Delta\tau$$

GRAIN DRYING OPERATING ENERGY (BTU)

$$GDHOPE = \Sigma [56.8833 \times EP101] \times \Delta\tau$$

FOR MODE 9 ONLY

GRAIN DRYING SOLAR FRACTION (PERCENT)

$$GDSFR = 100.00$$

FOR MODE 9 ONLY

GRAIN DRYING ELECTRICAL SAVINGS (BTU)

$$GDHSVE = - \text{GRAIN DRYING OPERATING ENERGY}$$

GRAIN DRYING FOSSIL SAVINGS (BTU)

$$GDHSVF = \text{GRAIN DRYING SOLAR FRACTION/HEFF}$$

WHERE HEFF IS THE AUXILIARY CONVERSION EFFICIENCY

APPENDIX C

LONG-TERM AVERAGE WEATHER CONDITIONS

SITE: SCATTERGOOD 9. LOCATION: WESTBRANCH IA
 ANALYST: K. SHENFISH FDRIVE NO.: 61.
 COLLECTOR TILT: 50.00 (DEGREES) COLLECTOR AZIMUTH: 0.0 (DEGREES)
 LATITUDE: 41.80 (DEGREES) RUN DATE: 6/07/79

MONTH	HOBAR	HBAR	KBAR	RBAR	SBAR	HDD	CDD	TBAR
JAN	1230.	546.	0.44371	1.864	1017.	1362	0	21.
FEB	1701.	822.	0.48344	1.549	1274.	1109	0	25.
MAR	2320.	1132.	0.48796	1.229	1391.	920	0	35.
APR	2976.	1478.	0.49682	0.986	1458.	442	0	50.
MAY	3448.	1777.	0.51545	0.847	1504.	184	62	61.
JUN	3643.	2002.	0.54954	0.789	1579.	21	193	71.
JUL	3541.	1973.	0.55706	0.813	1604.	0	302	75.
AUG	3155.	1737.	0.55048	0.926	1608.	11	258	73.
SEP	2554.	1372.	0.53710	1.138	1561.	52	68	65.
OCT	1880.	1010.	0.53738	1.472	1487.	345	16	54.
NOV	1339.	603.	0.45443	1.774	1080.	763	0	39.
DEC	1103.	442.	0.40120	1.908	844.	1200	0	26.

LEGEND:

HOBAR ==> MONTHLY AVERAGE DAILY EXTRATERRESTRIAL RADIATION (IDEAL) IN BTU/DAY-FT².
 HBAR ==> MONTHLY AVERAGE DAILY RADIATION (ACTUAL) IN BTU/DAY-FT².
 KBAR ==> RATIO OF HBAR TO HOBAR.
 RBAR ==> RATIO OF MONTHLY AVERAGE DAILY RADIATION ON TILTED SURFACE TO THAT ON A HORIZONTAL SURFACE FOR EACH MONTH (I.E., MULTIPLIER OBTAINED BY TILTIN).
 SBAR ==> MONTHLY AVERAGE DAILY RADIATION ON A TILTED SURFACE (I.E., RBAR * HBAR) IN BTU/DAY-FT².
 HDD ==> NUMBER OF HEATING DEGREE DAYS PER MONTH.
 CDD ==> NUMBER OF COOLING DEGREE DAYS PER MONTH.
 TBAR ==> AVERAGE AMBIENT TEMPERATURE IN DEGREES FAHRENHEIT.