

231585

UCRL-ID-126191

Conceptual Designs for the AT-400MO Package

L. E. Fischer
R. F. Hafner
J. Hovingh
S. C. Keeton
E. W. Russell
J. Lemmings

January 1997

The logo for Lawrence Livermore National Laboratory, featuring a stylized 'L' symbol above the text 'Lawrence Livermore National Laboratory' which is arranged in a triangular shape.

Lawrence
Livermore
National
Laboratory

This is an informal report intended primarily for internal or limited external distribution. The opinions and conclusions stated are those of the author and may or may not be those of the Laboratory.

Work performed under the auspices of the U.S. Department of Energy by the Lawrence Livermore National Laboratory under Contract W-7405-Eng-48.

DISCLAIMER

This document was prepared as an account of work sponsored by an agency of the United States Government. Neither the United States Government nor the University of California nor any of their employees, makes any warranty, express or implied, or assumes any legal liability or responsibility for the accuracy, completeness, or usefulness of any information, apparatus, product, or process disclosed, or represents that its use would not infringe privately owned rights. Reference herein to any specific commercial product, process, or service by trade name, trademark, manufacturer, or otherwise, does not necessarily constitute or imply its endorsement, recommendation, or favoring by the United States Government or the University of California. The views and opinions of authors expressed herein do not necessarily state or reflect those of the United States Government or the University of California, and shall not be used for advertising or product endorsement purposes.

This report has been reproduced
directly from the best available copy.

Available to DOE and DOE contractors from the
Office of Scientific and Technical Information
P.O. Box 62, Oak Ridge, TN 37831
Prices available from (615) 576-8401, FTS 626-8401

Available to the public from the
National Technical Information Service
U.S. Department of Commerce
5285 Port Royal Rd.,
Springfield, VA 22161

Conceptual Designs for the AT-400MO Package

**Prepared by
J. Lemmings
Mason and Hanger - Silas Mason Co., Inc.**

**L.E. Fischer
R.F. Hafner
J. Hovingh
S.C. Keeton
E.W. Russell
Lawrence Livermore National Laboratory**

**Prepared for
Mason and Hanger - Silas Mason Co., Inc.
Amarillo, Texas**

Abstract

Currently, Pantex handles and stores weapon pits in AT-400A packages. The Department of Energy (DOE) currently plans to oversee the conversion of weapon pits into plutonium metal or oxide. These products will then be stored, and perhaps transported at a later time, to other DOE sites. If DOE assigns the pit conversion process to Pantex, it makes sense to store the resulting Pu metal or oxide at Pantex, utilizing existing facilities, equipment, processes, and personnel.

The four conceptual designs presented herein substitute the current AT-400A containment vessel, designed for weapon pits, with a vessel designed to store and/or ship Pu metal or oxides. These new designs utilize the existing AT-400A overpack system—consisting of the drum assembly and radial impact limiters—and likewise employ existing AT-400A production operations, e.g., handling, loading, unloading, and leakage testing.

Table of Contents

Acknowledgments	vii
1.0 Introduction	1
2.0 Description of the AT-400MO Package.....	1
2.1 Regulatory and general requirements	1
2.2 Pu metal/oxide process can compatibility.....	2
2.3 Survey of current transportation packages	2
3.0 AT-400MO Conceptual Designs.....	3
3.1 AT-400MO-1.....	3
3.2 AT-400MO-2.....	4
3.3 AT-400MO-3.....	4
3.4 AT-400MO-4	4
4.0 AT-400MO Operational Description and Issues	5
5.0 AT-400MO Preliminary Design Analysis.....	5
6.0 AT-400MO Preliminary Cost Analysis	6
7.0 Summary and Conclusions.....	6
References	8

Tables

Table 1. Storage at Pantex DOE-STD-3013-96 Storage Requirements.....	9
Table 2. AT-400MO General Requirements for AT-400MO Storage and/or Transport Package	10
Table 3. Plutonium/Uranium Transport Packagings Currently in Use, Undergoing Certification or Re-Certification.....	11
Table 4. AT-400MO-1 Weight Calculations	14
Table 5. AT-400MO-2 Weight Calculations	15
Table 6. AT-400MO-3 Weight Calculations	16
Table 7. AT-400MO-4 Weight Calculations	17

Figures

Figure 1. AT-400 Container.....	18
Figure 2a. AT-400MO-1 Storage Packaging.....	19
Figure 2b. MO-1 Unit	20
Figure 3a. AT-400MO-2 Storage Package	21
Figure 3b. MO-2 Unit	22
Figure 4a. AT-400MO-3 Storage Packaging.....	23
Figure 4b. MO-3 Unit	24
Figure 5a. AT-400MO-4 Storage Packaging.....	25
Figure 5b. MO-4 Unit	26

Acknowledgments

This work was sponsored by Mason and Hanger—Silas Mason Co., Inc. The Technical Manager was Henry King who provided guidance on which storage and transport options to evaluate. Joel Watkins prepared the drawings for the four conceptual design options. Special thanks to Shelli Neal for her administrative support and to Lyssa Campbell for editing.

1.0 Introduction

The United States is currently embarking on an aggressive program to dismantle a portion of the nuclear weapons stockpile and dispose of or store the recovered nuclear materials. This dismantlement activity is carried out by Pantex in Amarillo, Texas. Currently, Pantex handles and stores weapon pits in AT-400A packages. The Department of Energy (DOE) currently plans to oversee the conversion of excess weapon pits into plutonium (Pu) metal or oxide. These products will then be stored, and perhaps transported at a later time, to other DOE sites. If DOE assigns the pit conversion process to Pantex, it makes sense to store the resulting Pu metal or oxide at Pantex, utilizing existing facilities, equipment, processes, and personnel.

The three conceptual designs presented herein substitute the current AT-400A containment vessel (Figure 1), designed for weapon pits, with a vessel designed to store and/or ship Pu metal or oxides. These new designs utilize the existing AT-400A overpack system—consisting of the drum assembly and radial impact limiters—and likewise employ existing AT-400A production operations, e.g., handling, loading, unloading, and leakage testing. This paper describes the design concepts for the primary and secondary containment vessel (PCV and SCV) for storing Pu in the form of metal or oxides.

The new containment vessel designs are completely compatible with AT-400A production facilities at Pantex, offering DOE the greatest amount of flexibility in transporting materials between sites. This compatibility allows Pantex to receive clean metals and oxides that have been packaged and transported in either (1) a complete storage/transport package, consisting of PCV/SCV units housed in the AT-400A overpack system, or (2) another licensed package, such as the Chalfant or Safekeg. All packages are in compliance with DOE-STD-3013-96^[1]. The PCV/SCV units would then be placed in proposed Pantex warehouse storage systems.

2.0 Description of the AT-400MO Package

2.1 Regulatory and general requirements

Table 1 summarizes the major requirements for storing Pu metals and oxides as specified in DOE-STD-3013-96. Many of these requirements are compatible with transportation regulations specified in 10 CFR 71^[2]. The most efficient package design will both store and transport Pu metal and oxides.

Table 2 summarizes the general requirements for a modified AT-400A package for storing, and possibly transporting, Pu metal and oxides. This package, called the AT-400MO, would use the AT-400A overpack system and be compatible with the AT-400A production facilities at Pantex.

2.2 Pu metal/oxide process can compatibility

The PCV/SCV design will be compatible with the BNFL, Inc. Plutonium Stabilization and Package System with convenience cans (4.4-in. diameter, 8.4 in. tall), or other systems that use the "Tuna Can" (3.38-in. diameter, 2 in. tall) or "Tomato Can" (4-in. diameter, 4.6 in. tall) for transport in the DOE specification 6M/2R packagings. The convenience cans utilize a sphincter seal (metal-to-metal closure), which can relieve possible pressure build-ups. The Tuna and Tomato cans, on the other hand, utilize welded closures and would not relieve potential pressure build-ups. Although loading the convenience can into a PCV would require remote handling operations, the sphincter seal should have adequate reliability for routine operations. This operation is anticipated to be carried out in a "clean" glove-box system.

2.3 Survey of current transportation packages

Lawrence Livermore National Laboratory (LLNL) staff conducted a survey of the plutonium packagings (1) currently in use, (2) under recertification, and/or (3) in the process of being certified. The primary source of survey data was gathered through a search of the RAMPAC^[3] database. Additional data sources were from the information presented in NUREG 0383^[4] and from informal communications with personnel at DOE Headquarters and at DOE/AL. Packagings eliminated from the outset, on both a national and international basis, were those limited to the shipment of plutonium in Special Form, as defined in 10 CFR 71.4. The results of this survey are shown in Table 3.

An overview of these results shows that, with the exception of the 5320 and Mound 1kW packagings—which are used primarily for the transport of plutonium-238—the only packagings currently certified for the transport of plutonium are the Chalfant 30 and the Chalfant 35. Also referred to as the 9965 and 9968 packagings, the former is certified for the transport of plutonium metal and the latter is certified for the transport of plutonium oxides and powders. The two different configurations of the same basic packaging design have been shown to be in full compliance with the single-containment vs. double-containment requirements specified in 10 CFR 71.63.

Technically, the 9965 and 9968 packagings are in the process of being recertified. They are, however, the only packagings that can be used because, for the most part, the other packagings listed in Table 3 (i.e., the 9972, 9973, 9974, and 9975 packagings, the Safekeg 2863B packaging, and the AT-400A, AT-400B, and AT-400R packagings) have yet to be certified.

The DOT Specification 6M/2R packagings in 15-, 30-, 55-, and 110-gallon drum configurations also listed in Table 3 are shown for completeness. In general, these packagings provide single containment and cannot be leak checked to ANSI N15.4 therefore they were eliminated from further consideration.

3.0 AT-400MO Conceptual Designs

The design bases for the AT-400MO include:

- DOE-STD-3013-96 for storage
- 10 CFR 71 for transport
- ASME Boiler and Pressure Vessel Code (B&PVC), Section III, Subsection NB^[5].

The latter is the NRC-recommended National Standard for design/fabrication quantitative acceptance criteria to meet the safety requirements of 10 CFR 71 for Type-B packages. Three AT-400MO design concepts were prepared and evaluated using the general requirements of Table 2, and will accommodate one to three convenience cans with the AT-400A overpack system.

3.1 AT-400MO-1

The first AT-400MO conceptual design (AT-400MO-1) meets or exceeds all of the requirements of DOE-STD-3013-96 and Table 2, but is for storage only. Both the PCV and SCV can be transported as an MO-1 unit in Chalfant or Safekeg transport packagings. Prior to transport, an MO-1 storage unit has to be removed from the AT-400MO-1 package and placed into a Chalfant or Safekeg package for transport. Only one MO-1 storage unit can be shipped at a time in these existing transport packages.

The AT-400MO-1 storage-packaging design is shown in Figure 2 a-b. Both the PCV and SCV are completely welded containment systems. The outer diameter of the SCV is 4.9 in. and the height is 10.0 in. A single unit consisting of the convenience can, PCV, and SCV will fit inside the AT-400A overpack system. An aluminum basket centers the single unit in the overpack and conducts heat to the overpack inner wall. After the PCV is put inside the SCV and the SCV is welded shut, the PCV can no longer be leak tested without cutting open the SCV. The MO-1 storage unit design, which uses completely welded containment systems, is recommended for transport in a separate certified transport packaging such as the Chalfant and Safekeg package. Because the walls of the PCV and SCV designs are relatively thin to meet geometry constraints, they may not be able to withstand all transport loading conditions alone, even with the AT-400 overpack system. Also, prior to transporting, 10 CFR 71 requires leak testing of both containment vessels, which would require cutting open the SCV and then rewelding it shut after leak testing the PCV. If the Chalfant or Safekeg packaging is used, the leakage test would be performed on the transport package containment vessels which are sized to withstand all transport conditions. The AT-400MO-1 design has an overall weight of 257 pounds. The weight calculations are listed in Table 4.

3.2 AT-400MO-2

The second conceptual design, AT-400MO-2, meets most of the requirements of DOE-STD-3013-96. This design uses a bolted SCV with double seals and allows leak testing of both containment vessels for transport in the AT-400MO-2 packaging. This design does not meet the literal requirements of two welded closures implied in DOE-STD-3013-96, but meets its intent by using an equivalent design with two seals. The AT-400MO-2 storage and transport design is shown in Figure 3 a-b. The outer diameter of the SCV is 5.3 in. and the height is 12.0 in..

The bolted SCV in the AT-400MO-2 concept can accommodate a single welded PCV with a convenience can as shown in Figure 3b. Alternatively, the MO-1 storage unit shown in Figure 2b can be accommodated in the SCV this allows flexibility in meeting storage and transportation requirements with either a double or triple containment system. The conceptual design shown in Figure 3 a-b uses a bore seal design. Alternatively, a flat face seal design can be used and still meet all weight and geometry constraints. The total weight of the AT-400MO-2 concept does not exceed 273 lbs. The weight calculations are listed in Table 5.

3.3 AT-400MO-3

The third conceptual design, AT-400MO-3 is similar to the AT-400MO-2 design but has twice the payload capacity. This design stacks either two welded PCVs or two MO-1 storage units on top of each other inside of a single bolted SCV. The conceptual design shown in Figure 4 a-b uses a flat face seal design. The maximum weight of the AT-400MO-3 is 318 lbs. The weight calculations are listed in Table 6. The maximum heat flux is 20 watts.

3.4 AT-400MO-4

The fourth conceptual design, AT-400MO-4 is also similar to the AT-400MO-2 design but has three times the payload capacity. This design arranges three bolted SCV in a symmetrical pattern shown in Figure 5 a-b. Each SCV contains either a welded PCV or a MO-1 storage unit. This design can use only a bore seal design for the SCV because of weight and geometry constraints. The design also requires the use of neutron poisons to maintain subcriticality with a $k_{eff} \leq 0.95$ for all conditions. The maximum weight of the AT-400MO-4 is 358 pounds, which slightly exceeds the 350 pounds design limit the weight calculations are listed in Table 7. The maximum heat flux is 30 watts, which exceeds the 20 watts limit on the AT-400A package.

4.0 AT-400MO Operational Description and Issues

The process requirements for compatibility with the BNFL system are summarized in the following steps for loading a convenience into a MO-1 storage unit:

- (1) Load convenience can into helium-filled PCVs in glove box, and perform closure weld.
- (2) Perform leak check of PCV.
- (3) Load PCV into helium-filled SCV and perform mechanical closure.
- (4) Perform leak-check and contamination-check on SCV.
- (5) Dispatch the storage systems to proposed Pantex warehouse storage system.

The operational details for the above process will be developed after a preliminary design has been completed and chosen.

5.0 AT-400MO Preliminary Design Analysis

The AT-400A overpack system should adequately protect the contents under all accident and transport conditions for the AT-400MO-2 through -4 designs. Accident analyses for transport will be performed after a preliminary design has been prepared.

Criticality safety, thermal, pressure, and stress analyses were performed on the AT-400MO-1 through AT-400MO-4 packaging configurations for normal storage conditions. The simplified analyses indicate that the conceptual designs are feasible.

The most limiting cases for the criticality, thermal, pressure and stress analyses were for the AT-400MO-4 package which will be described.

The simplified nuclear criticality model used for the calculations ignored any steel material in the cans or containers and used either a homogeneous mixture of 5.1 kg of PuO₂ or 4.5 kg of Pu metal with water to completely fill PCV or a 4.5 kg Pu metal sphere or metal wedge in most reactive location with water in each PCV. The entire triangular arrangement of the convenience cans for the AT400MO-4 design was surrounded with 30 cm of water to provide a fully water reflected boundary. The K_{eff} for this configuration is less than 0.95, but requires the use of neutron poisons in the design. Infinite three dimensional square lattices of this AT400MO-4, with each PCV containing a 4.5 kg Pu metal sphere in most reactive location, gave a K_{eff} less than 0.95.

The simplified thermal analysis used the characteristics of the AT-400A overpack system to estimate its inner wall temperature at 92°C. The heat flow was assumed to be by contact in only the 6061-T6 aluminum basket. The maximum temperature calculated for the commercial can was 147°C.

The water vapor desorbed from the plutonium oxide will cause most of the pressure in the primary containment vessel. Assuming that the temperature of the water vapor is at the temperature of the convenience can, the saturation pressure at 147°C is 64.6 psia (50 psig).

For a primary storage containment vessel with a diameter of 4.7 in. and a wall thickness of 0.12 in., the maximum stress from a pressure difference of 50 psi is about 18000 psi in the bottom flat plate. This stress is acceptable for most stainless steels at 147°C.

6.0 AT-400MO Preliminary Cost Analysis

The following discussion involves evaluation of the AT-400MO conceptual design production costs based on a total capacity of 10,000 to 20,000 packages. The manufacturing processes that were evaluated are consistent with functional and performance requirements allotted to each packaging component. It was assumed that qualification of all fabrication contractors and subcontractors would be required per an ASME NQA-1 type quality assurance program, and the technical requirements would be dictated by the ASME Boiler and Pressure Code, Section III, Subsection NB for containment-related components and Subsection NF (Reference 6) or equivalent for other safety-related features. These cost estimates are “ballpark;” the final packaging cost presented here reflects an uncertainty range of roughly 200%. The following are the packaging costs for the three conceptual designs:

(1)	AT-400MO-1	\$2.3K
(2)	AT-400MO-2	\$3.1K
(3)	AT-400MO-3	\$4.9K*
(4)	AT-400MO-4	\$6.4K

7.0 Summary and Conclusions

Conceptual designs were developed for the storage and transport of Pu in the form of metal or oxides at Pantex, utilizing existing facilities, equipment, processes and personnel as much as possible. The conceptual designs are completely compatible with the AT-400A production operations and would utilize the AT-400A overpack system.

*Based on two MO-1 storage units inside SCV

The concepts meet the overall storage requirements of DOE-STD-3013-96 and the transportation requirements of 10 CFR 71. Criticality safety, thermal, pressure and stress analyses were performed on the AT-400MO packaging configurations for normal storage conditions. These simplified analyses indicate that these conceptual designs are feasible. PCV and SCV design/fabrication processes are specified to meet the requirements of the ASME Boiler and Pressure Vessel Code, Section III, Subsection NB, which is the NRC-recommended National Standard for design/fabrication quantitative acceptance criteria for Type-B packages. The AT-400MO-3 storage/transport package has two times the capacity of existing transportation packages. The AT-400MO-2 packaging is expected to cost approximately the same amount per packaging as existing transport packagings.

References

1. U.S. Department of Energy. *Criteria for Packaging of Plutonium Metals and Oxides for Long-Term Storage*. DOE-STD-3013-96.
2. U.S. Code of Federal Regulations. "Packaging and Transportation of Radioactive Material." Title 10, Part 71. Washington, DC, April 1, 1996.
3. Analysas Corporation. *Radioactive Materials Packages (RAMPAC) Database, User's Manual*. Revised October 24, 1994.
4. U.S. Nuclear Regulatory Commission. *Director of Certificates of Compliance for Radioactive Materials Packages*. Certificates of Compliance. NUREG-0383, Volume 2, Revision 18, October 1995.
5. American Society of Mechanical Engineers. *Boiler and Pressure Vessel Code*. Section III, Division 1, Subsection NB, "Class 1 Components." New York.
6. American Society of Mechanical Engineers. *Boiler and Pressure Vessel Code*. Section III, Division 1, Subsection NF, "Component Supports." New York.

Table 1. Storage at Pantex DOE-STD-3013-96 Storage Requirements

- Corrosion-resistant PCV/SCV material
- Two welded leaktight containment vessels
- Stabilizing atmosphere
- Leak-tightness per ANSI N14.5 after drop test
- Non-Destructive Assay (NDA), material verification, and inspection and surveillance
- Permanent identification
- Designed and proof-tested to 1.5 times the calculated theoretical maximum internal pressure
- Free of combustible or organic material
- Nondestructive indication of an internal pressure buildup at less than 690 kPa (100 psig)
- Material properties:
 - thermal output of less than 30 Watts
 - for metal, quantity < 4.4 kg
 - for oxides, quantity < 5.0 kg
- Use existing Pu transport packages
 - 4.9-in. outer diameter for secondary containment vessel
 - 10.0-in. length for secondary containment vessel

Table 2. AT-400MO General Requirements for AT-400MO Storage and/or Transport Package

- Compatible with all AT-400A operations
- Weight compatible with AT-400A weight limitation of 350 pounds
- Dimensional limitations per inside contour of AT-400A overpack and subcriticality requirements
- PCV/SCV design life: minimum of 50 years
- Weapons grade plutonium only
- Tamper detection mechanism
- PCV/SCV design and fabrication per the ASME Boiler and Pressure Vessel Code, Section III
- Quality Assurance/Quality Control per QC-1; 10 CFR 71, Subpart H and DOE-STD-3013-96
- Compatible with the BNFL Plutonium Stabilization and Package System convenience cans or equivalent
 - 4.4-in. inner diameter for primary containment vessel
 - 8.4-in. inner length for primary containment vessel
- Complies with DOE-STD-3013-96 (Table 1)
 - Equivalent bolted closure with two seals for secondary containment allowed
 - Compatible with existing transport packages as alternates
- Complies with 10 CFR 71

**Table 3. Plutonium/Uranium Transport Packagings Currently in Use, Undergoing Certification or Re-Certification
Complied by: R.S. Hafner, LLNL/FESSP**

Package ID Number	Generic Name	Certifying Agency	Containment System	Generic Package Description	Overall Height (In.)	Overall Diameter (In.)	Gross Weight (lbs.)	Allowable Contents	Maximum Payload (Watts)	Maximum Plutonium Payload (grams)	Comments
N/A	DOT-6M/2R	DOT/DOE	Single	15-Gallon Drum	26.9	14.9	160	Pu-238 Capsules; Plutonium Metal, Ceramics, & Oxides	10	See DOE/RL-94-68, Sections 5.0 and 18.0	Currently in Use
N/A	DOT-6M/2R	DOT/DOE	Single	30-Gallon Drum	29.1	19.6	480	Plutonium Metal, Alloys & Oxides; Uranium Metal & Compounds	10	See DOE/RL-94-68, Sections 11.0 through 15.0	Currently in Use
N/A	DOT-6M/2R	DOT/DOE	Single	55-Gallon Drum	34.8	23.9	640	Plutonium; Uranium Metal, Oxides & Compounds	10	See DOE/RL-94-68, Sections 9.0, 11.0, 16.0, and 19.0	Currently in Use
N/A	DOT-6M/2R	DOT/DOE	Single	110-Gallon Drum			640	Plutonium Metal & Oxide; Uranium Metal, Oxides & Compounds	10	See DOE/RL-94-68, Sections 5.0, 10.0, 11.0 and 17.0	Currently in Use
USA/5320/B()F	5320	DOE	Double	"R2D2" on Rollers	32.0	16.8	327	Plutonium Oxides	203	357	Currently in Use; Recertification Process in Progress
USA/5320/B(M)F	Replacement 5320	DOE	Double	"R2D2" on Rollers	32.0	16.8	327	Plutonium Oxides	203	357	Replacement Package; Certification Process in Progress

Table 3. Plutonium/Uranium Transport Packagings Currently in Use, Undergoing Certification or Re-Certification, cont'd.

Package ID Number	Generic Name	Certifying Agency	Containment System	Generic Package Description	Overall Height (in.)	Overall Diameter (in.)	Gross Weight (lbs.)	Allowable Contents	Maximum Payload (Watts)	Maximum Plutonium Payload (grams)	Comments
USA/9516/B(M)F-85	Mound 1 kW	DOT	Double	30.75 in. x 30.75 in. x 35.25 in. Cage w/CV in Bottom Center	35.3	30.75 in. x 30.75 in.	900	Pu-238 Oxide	500	1,000	Currently in Use
USA/9516/B(U)F	Mound 1 kW	DOE	Double	30.75 in. x 30.75 in. x 35.25 in. Cage w/CV in Bottom Center	35.3	30.75 in. x 30.75 in.	900	Pu-238 Oxide	500	1,000	Currently in Use
USA/9516/B(U)F-85	Mound 1 kW	DOT	Double	30.75 in. x 30.75 in. x 35.25 in. Cage w/CV in Bottom Center	35.3	30.75 in. x 30.75 in.	900	Pu-238 Oxide	500	1,000	Currently in Use
USA/9965/B(U)F	Chalfant 30 Single	DOE	Single	30-Gallon Drum	29.1	19.6	145	Pu-239 Metal; U-235 Metal/Oxide	10	4,400	Currently in Use; Recertification Process in Progress
USA/9968/B(U)F	Chalfant 35 Double	DOE	Double	35-Gallon Drum	35.5	19.6	360	Pu-238 Oxide; Pu-239 and U-235 Oxide Mix; Pu-239 Oxide w/up to 5% Am-241	18	4,300	Currently in Use; Recertification Process in Progress
USA/9972/B(U)F	Replacement Chalfant 30 Single	DOE	Single	30-Gallon Drum	29.1	19.6	145	Pu-239 Metal; U-235 Metal/Oxide	11	4,400	Replacement Pkg.; Certification Process in Progress
USA/9973/B(U)F	N/A	DOE	Double	30-Gallon Drum	29.1	19.6	187	Pu-239 and U-235 Oxide Mix	13	4,400	Replacement Pkg.; Certification Process in Progress

Table 3. Plutonium/Uranium Transport Packagings Currently in Use, Undergoing Certification or Re-Certification, cont'd.

Package ID Number	Generic Name	Certifying Agency	Containment System	Generic Package Description	Overall Height (In.)	Overall Diameter (In.)	Gross Weight (lbs.)	Allowable Contents	Maximum Payload (Watts)	Maximum Plutonium Payload (grams)	Comments
USA/9974/B(U)F	N/A	DOE	Double	55-Gallon Drum	34.8	23.9	629	Pu-239 and U-235 Oxide Mix	14	4,400	Replacement Package; Certification Process in Progress
USA/9975/B(U)F	Replace-ment Chalfant 35 Double	DOE	Double	35-Gallon Drum	35.5	19.6	360	Pu-238 Oxide; Pu-239 and U-235 Oxide Mix; Pu-239 Oxide w/up to 5% Am-241	19	4,300	Replacement Package; Certification Process in Progress
USA/ /B(U)	Safekeg 2863B	DOE	Double	30-Gallon Keg	30.0	16.7	238	Pu-238 Oxide; Pu-239 Metal/Oxide; and U-235 Metal/Oxide	40	9,000	New Package; Certification Process in Progress
USA/ /B(U)	AT-400A	DOE	Single	30-Gallon Drum	29.1	19.6	309	Weapons Components	Classified	Classified	New Package; Certification Process in Progress
USA/ /B(U)	AT-400B	DOE	Single	30-Gallon Drum	29.1	19.6	300	Weapons Components	Classified	Classified	New Package; Design Process in Progress
N/A	AT-400R	N/A	Single	30-Gallon Drum	29.1	19.6	300	Weapons Components	Classified	Classified	DoD Package; Built for use in Russia; Certification Process Status Unknown
N/A	3013 Standard	N/A	Single	30-Gallon Drum*	29.1*	19.6*	N/A	Pu Metal	30	4,500	Standard Requirements
N/A	3013 Standard	N/A	Double	30-Gallon Drum*	29.1*	19.6*	N/A	Pu Oxide	30	5,100	Standard Requirements
* Implied from Other Dimensions											

Table 4. AT-400MO-1 Weight Calculations

AT400MO-1: 1 CONVENIENCE CAN IN 1 WELDED PRIMARY & 1 WELDED SECONDARY CONTAINER
 WEIGHT CALCULATIONS J.WATKINS 11-12-96

PART	QTY	MATERIAL	WEIGHT (LBS)
OVERPACK DRUM W/ IMPACT LIMS	1	304 SST/FOAM	199
INTERNAL FOAM	A/R	FOAM	5.3
CONDUCTING PLATE	1	ALUM	3.4
BASKET	1	ALUM	3.7
CENTERING PLATE, LOWER	1	304 SST	10.8
CENTERING PLATE, UPPER	1	304 SST	10.3
-CONTAINMENT VESSEL-	3		24.8
Each Containment Vessel contains the following:			
PRIMARY CONTAINMENT VESSEL	1	304 SST	3.9
PRIMARY CONTAINMENT LID	1	304 SST	.8
SECONDARY CONTAINMENT VESSEL	1	304 SST	4.6
SECONDARY CONTAINMENT LID	1	304 SST	2.3
CONVENIENCE CAN	1	304 SST	2.4
CONVENIENCE CAN LID	1	304 SST	.9
4.5kg OF PuOx IN CONV CAN	1	PuOXIDE	9.9
TOTAL WEIGHT			257.3 LBS

NOTES:

Overpack drum weight is estimated at 196 pounds including the 2 impact limiters shown in the AT-400A pit design. The impact limiters used for this weight calculation are 8.4" thick and their weight is estimated.

Table 5. AT-400MO-2 Weight Calculations

AT400MO-2 : 1 CONVENIENCE CAN IN 1 WELDED PRIMARY & 1 SECONDARY CONTAINER
 WEIGHT CALCULATIONS J.WATKINS 11-13-96

PART	QTY	MATERIAL	WEIGHT (LBS)
OVERPACK DRUM W/ IMPACT LIMS	1	SST/FOAM	198
INTERNAL FOAM	A/R	FOAM	5.3
CONDUCTING PLATE	1	ALUM	3.2
BASKET	1	ALUM	4.2
CENTERING PLATE, LOWER	1	SST	10.8
CENTERING PLATE, UPPER	1	SST	10.9
-CONTAINMENT VESSEL-	1		(40.7)
Each Containment Vessel contains the following:			
PRIMARY CONTAINMENT VESSEL	1	SST	7.9
PRIMARY CONTAINMENT LID	1	SST	1.2
SECONDARY CONTAINMENT VESSEL	1	SST	12.1
SECONDARY CONTAINMENT LID	1	SST	5.6
CONVENIENCE CAN	1	SST	2.4
CONVENIENCE CAN LID	1	SST	.9
4.5kg OF PuO IN CONV CAN	1	PuOXIDE	9.9
PINTLE	1	SST	.7
TOTAL WEIGHT			273.1 LBS

NOTES:

Overpack drum weight is estimated at 196 pounds including the 2 impact limiters shown in the AT-400A pit design. The impact limiters used for this weight calculation are 7.25" thick and their weight is estimated.

Table 6. AT-400MO-3 Weight Calculations

AT400MO-3 : 2 CONVENIENCE CANS IN 2 PRIMARY & 1 SECONDARY CONTAINERS
 WEIGHT CALCULATIONS J.WATKINS 11-15-96

PART	QTY	MATERIAL	WEIGHT (LBS)	TOTAL WEIGHT
OVERPACK DRUM W/ IMPACT LIMS	1	SST/FOAM	192	192
INTERNAL FOAM	1	FOAM	3.0	3.0
CONDUCTING PLATE	2	ALUM	6.5	13.0
BASKET	1	ALUM	8.6	8.6
CENTERING PLATE, LOWER	1	SST	10.8	10.8
CENTERING PLATE, UPPER	1	SST	7.6	7.6
-MO-3 UNIT-	1			(82.7)
Each Containment Vessel contains the following:				
MO-1 UNIT	2	-	24.8	49.6
SECONDARY CONTAINMENT VESSEL	1	SST	23.6	
SECONDARY CONTAINMENT LID	1	SST	8.5	
INTERNAL SPACER .50" THK	1	POLY	.3	
PINTLE	1	SST	.7	
TOTAL WEIGHT				317.7

NOTES:

Overpack drum weight is estimated at 196 pounds including the 2 impact limiters shown in the AT-400A pit design. The impact limiters used for this weight calculation are 2.4" thick and their weight is estimated.

Table 7. AT-400MO-4 Weight Calculations

AT400MO-4 : 3 CONVENIENCE CANS IN SINGLE PRIMARY & SECONDARY CONTAINERS

WEIGHT CALCULATIONS

J.WATKINS 11-13-96

PART	QTY	MATERIAL	WEIGHT (LBS)	TOTAL WEIGHT
OVERPACK DRUM W/ IMPACT LIMS	1	SST/FOAM	198	198
INTERNAL FOAM	A/R	FOAM	3.0	3.0
BASKET	3	ALUM	4.2	12.6
CENTERING TUBE	1	ALUM	0.5	0.5
INTERNAL B4C, (CENTER TUBE)	1	B4C	1.5	1.5
CENTERING PLATE, LOWER	1	SST	10.3	10.3
CENTERING PLATE, UPPER	1	SST	10.4	10.4
-CONTAINMENT VESSEL-SHORT	3		40.7	122.1
Each Containment Vessel contains the following:				
PRIMARY CONT VESSEL	1	SST	7.9	
PRIMARY CONTAINMENT LID	1	SST	1.2	
SECONDARY CONT VESSEL	1	SST	12.1	
SECONDARY CONTAINMENT LID	1	SST	5.6	
CONVENIENCE CAN	1	SST	2.4	
CONVENIENCE CAN LID	1	SST	.9	
4.5kg OF PuO IN CONV CAN	1	PuOXIDE	9.9	
PINTLE	1	SST	.7	
TOTAL WEIGHT				358.4

NOTES:

Overpack drum weight is estimated at 196 pounds including the 2 impact limiters shown in the AT-400A pit design. The impact limiters used for this weight calculation are 7.25" thick and their weight is estimated.

Figure 1

AT-400A Container

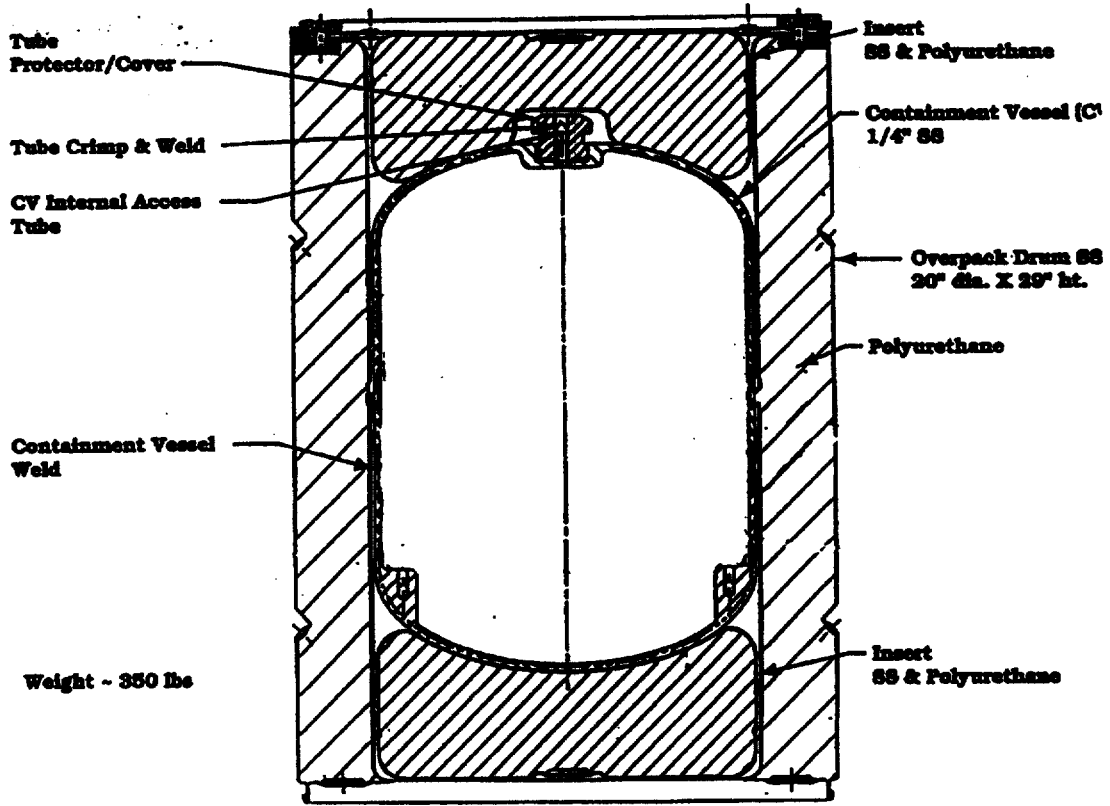
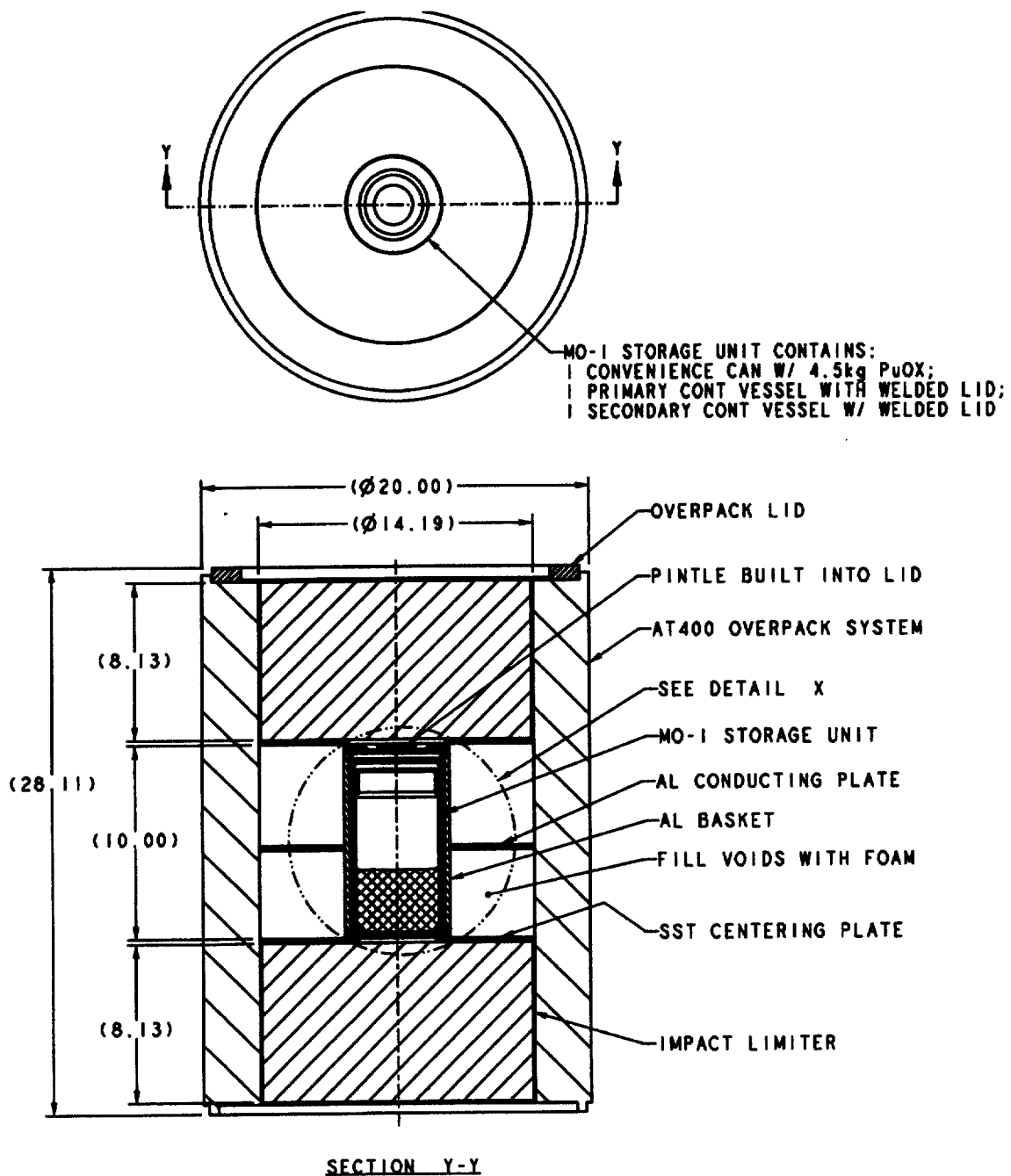

Figure 2a. AT-400MO-1 Storage Packaging



AT400MO-1 STORAGE PACKAGING

ESTIMATED WEIGHT = 257 POUNDS

DRAWN: J. WATKINS 11-12-96

Figure 2b. MO-1 Unit

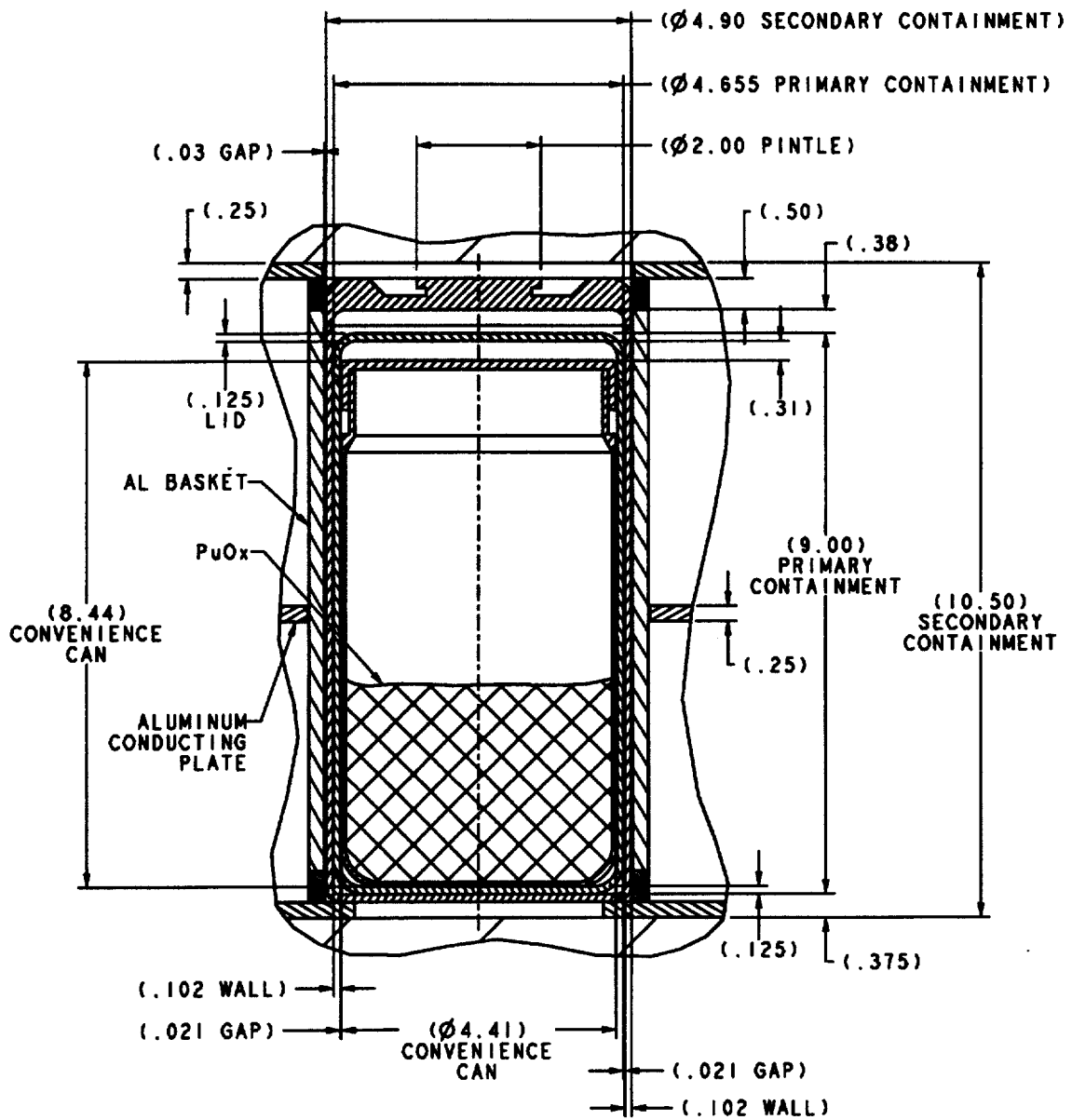

MO-1 STORAGE UNIT

Figure 3a. AT-400MO-2 Storage Package

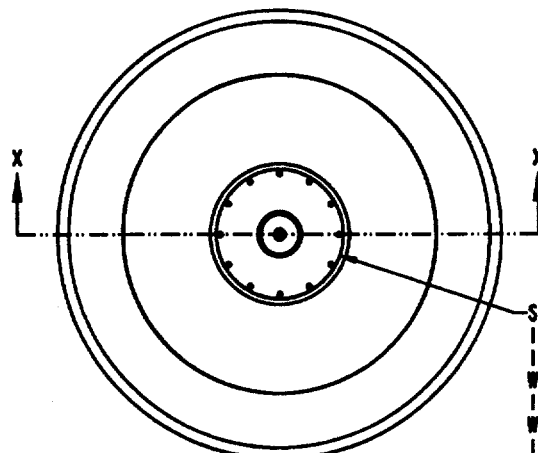

OVERPACK LID, UPPER IMPACT LIMITER
AND UPPER CENTERING PLATE REMOVED
IN THIS VIEW TO SHOW DETAIL

- SINGLE MO-2 UNIT CONTAINS:
 1 CONVENIENCE CAN W/ 4.5kg PuOx
 1 PRIMARY CONTAINMENT VESSEL
 WITH WELDED LID;
 1 SECONDARY CONTAINMENT VESSEL
 WITH BOLTED CLOSURE LID;
 1 LIFTING PINTLE;
 2 CENTERING PLATES;
 1 CENTERING ALUM RING.

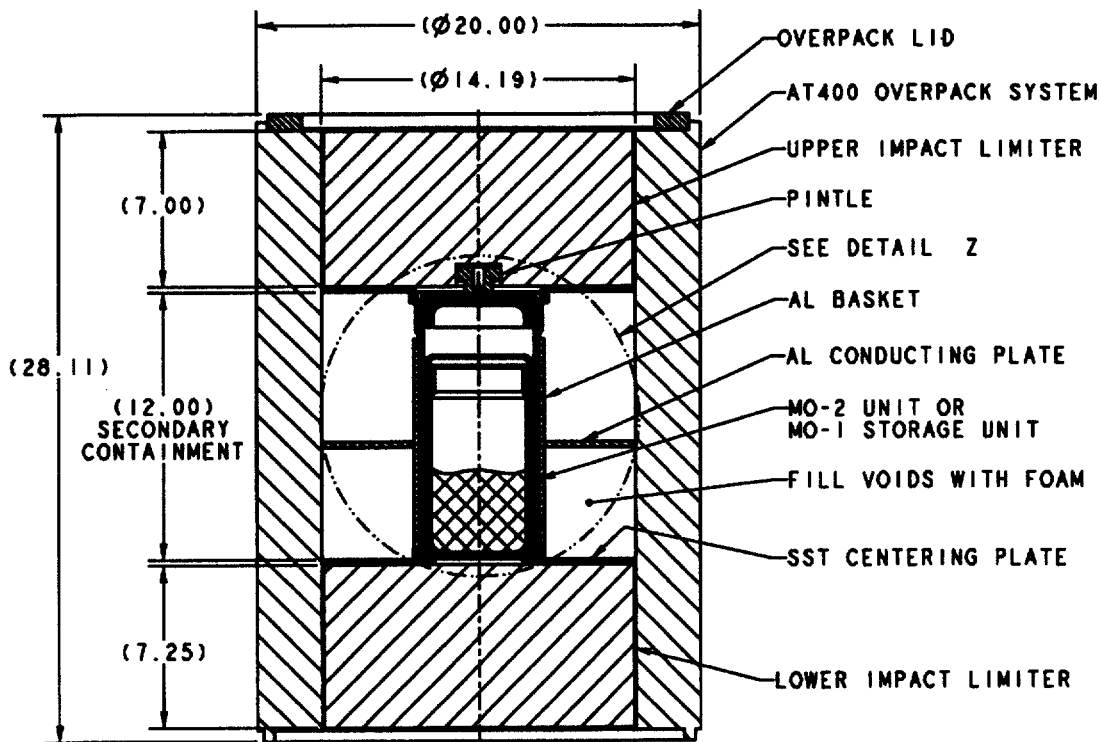

SECTION X-X

AT400MO-2 STORAGE AND TRANSPORT PACKAGING

ESTIMATED WEIGHT = 273 POUNDS

DRAWN: J. WATKINS 11-13-96

Figure 3b. MO-2 Unit

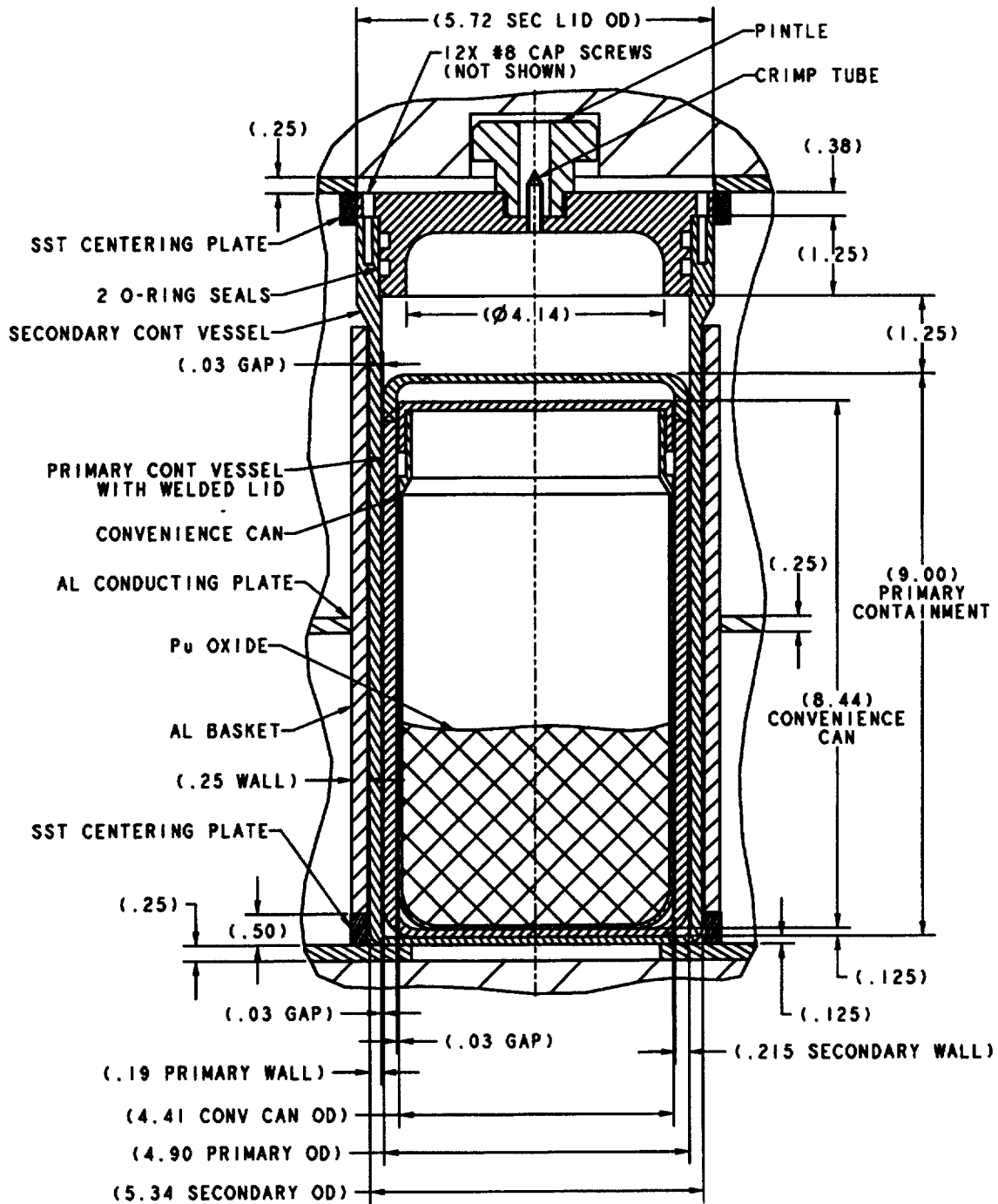

MO-2 UNIT

Figure 4a. AT-400MO-3 Storage Packaging

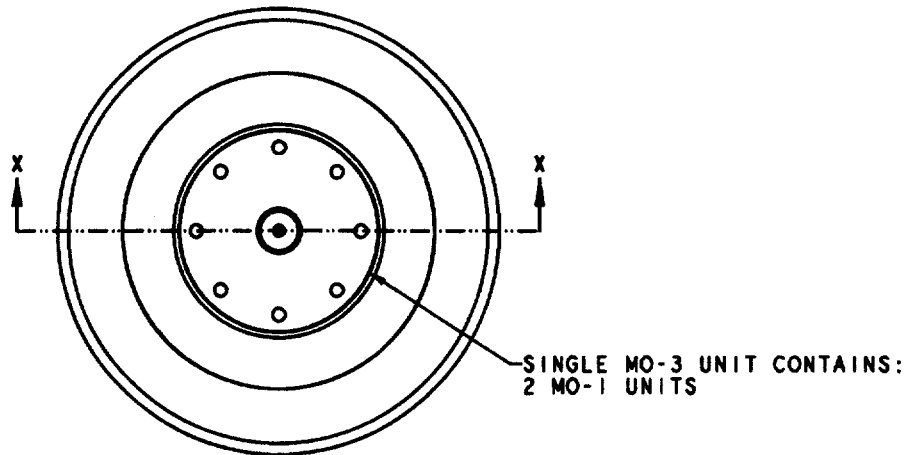

OVERPACK LID, UPPER IMPACT LIMITER
AND UPPER CENTERING PLATE REMOVED
IN THIS VIEW TO SHOW DETAIL

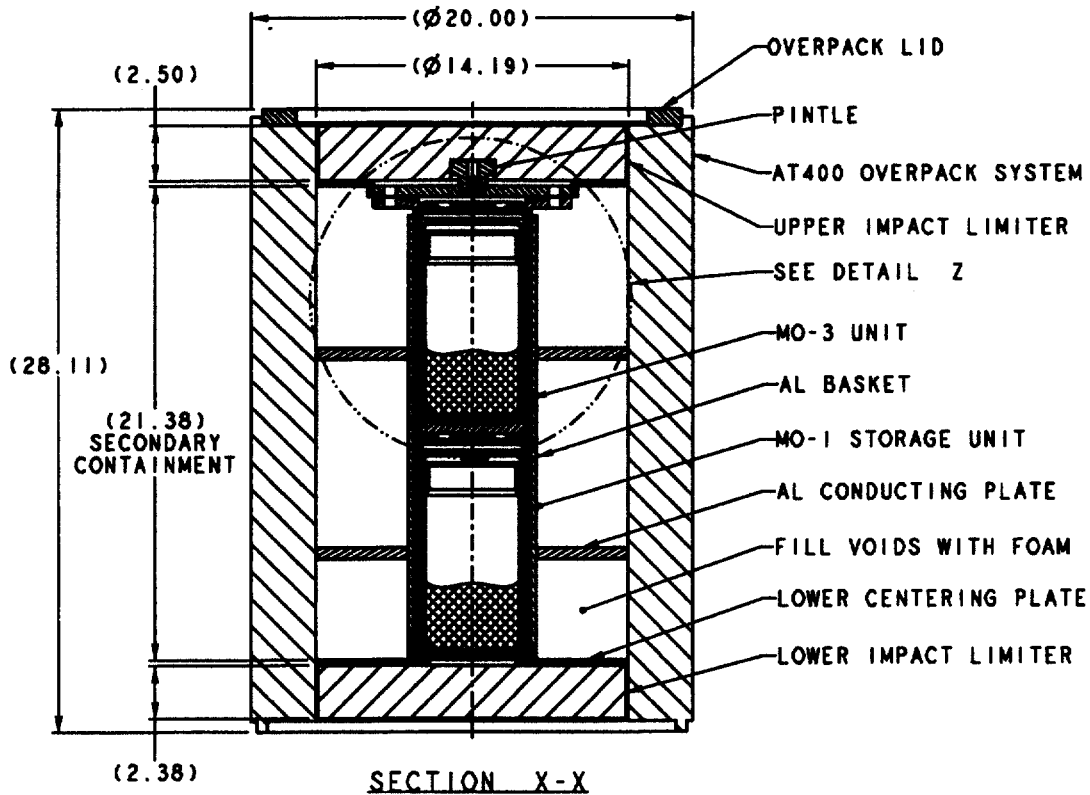

AT400MO-3 STORAGE AND TRANSPORT PACKAGING
ESTIMATED WEIGHT = 318 POUNDS
DRAWN: J. WATKINS 11-13-96

Figure 4b. MO-3 Unit

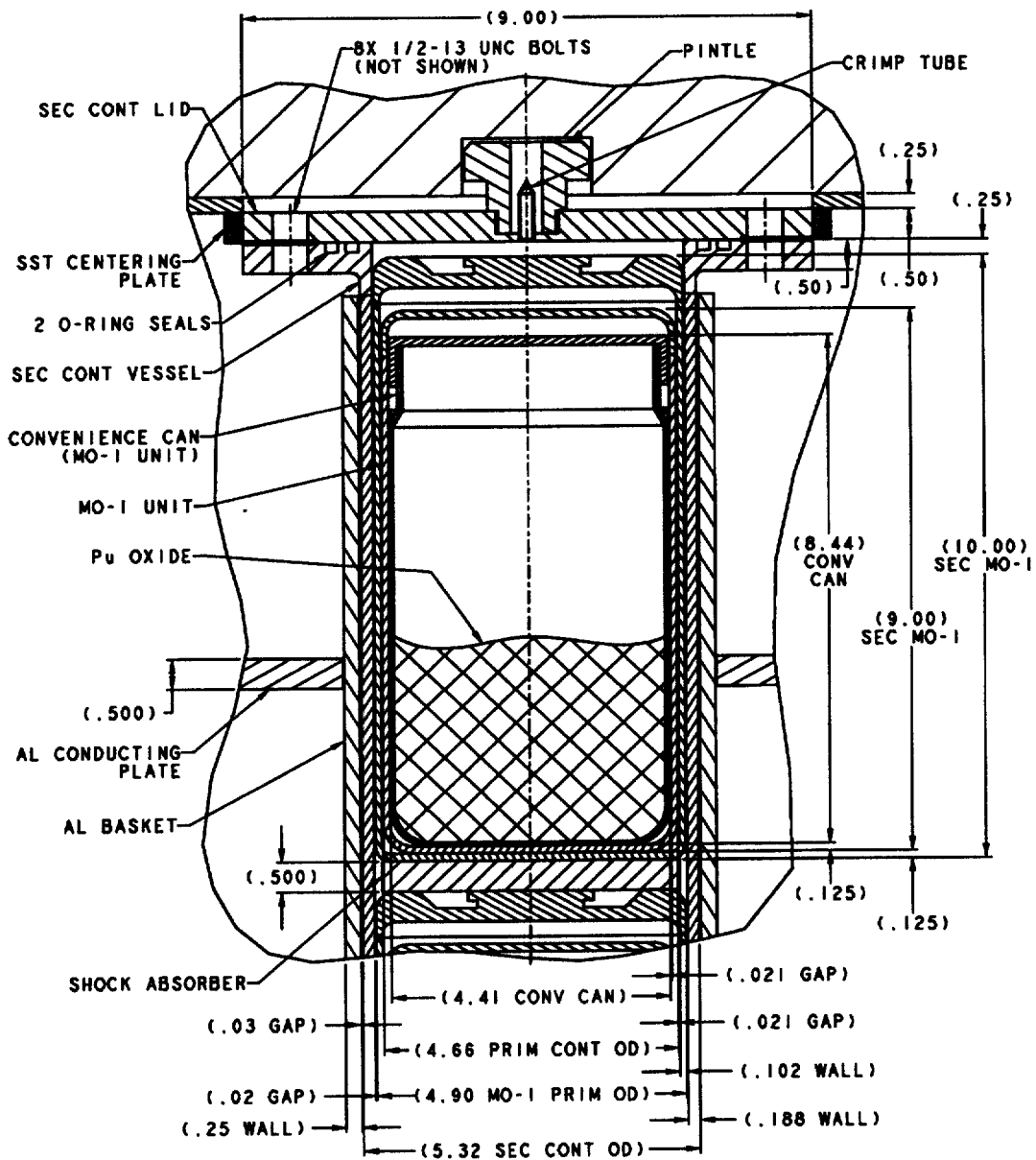

MO-3 UNIT

Figure 5a. AT-400MO-4 Storage Packaging

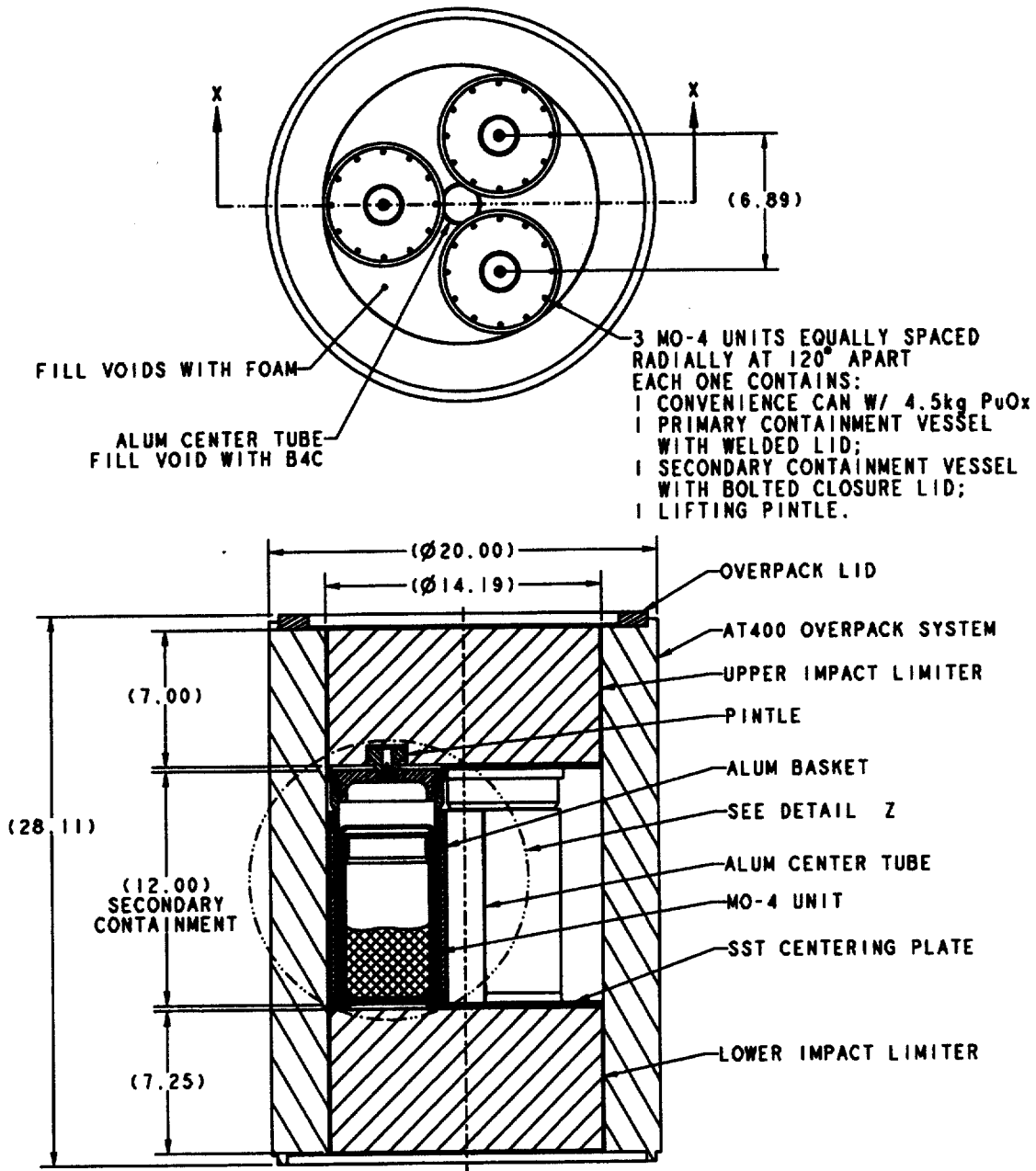

SECTION X-X

AT400MO-4 STORAGE AND TRANSPORTATION
ESTIMATED WEIGHT = 358 POUNDS
 DRAWN: J. WATKINS 11-13-96

Figure 5b. MO-4 Unit

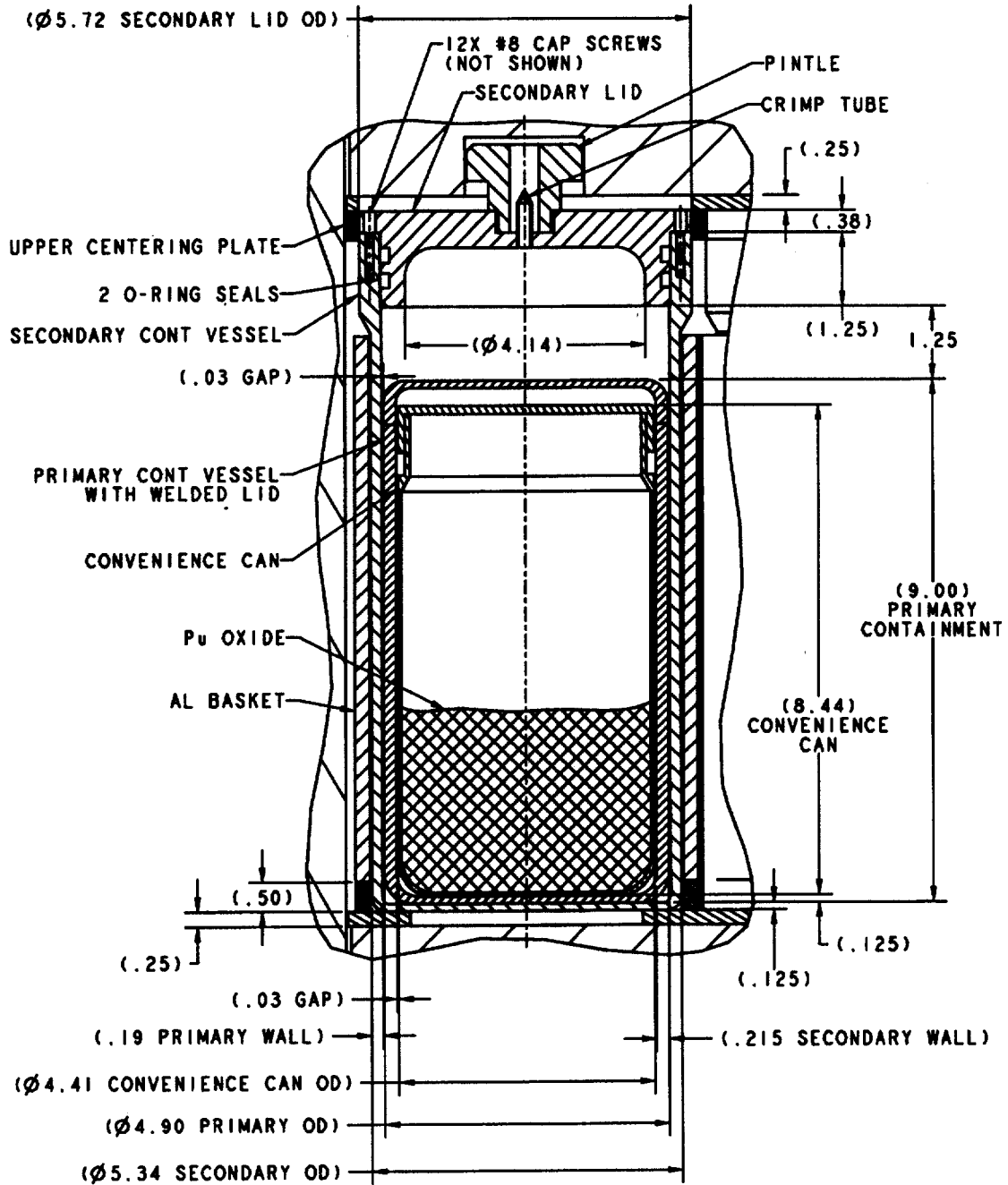

MO-4 UNIT

Technical Information Department • Lawrence Livermore National Laboratory
University of California • Livermore, California 94551

