

TNX GeoSiphon Cell (TGSC-1) Phase I Deployment/Demonstration Final Report

by

M. A. Phifer

Westinghouse Savannah River Company
Savannah River Site
Aiken, South Carolina 29808

F. C. Sappington

M. E. Denham

RECEIVED
MAR 27 1998
OSTI

MASTER

DOE Contract No. DE-AC09-96SR18500

This paper was prepared in connection with work done under the above contract number with the U. S. Department of Energy. By acceptance of this paper, the publisher and/or recipient acknowledges the U. S. Government's right to retain a nonexclusive, royalty-free license in and to any copyright covering this paper, along with the right to reproduce and to authorize others to reproduce all or part of the copyrighted paper.

DISTRIBUTION OF THIS DOCUMENT IS UNLIMITED



TNX GEOSIPHON CELL (TGSC-1)

PHASE I

DEPLOYMENT / DEMONSTRATION FINAL REPORT (U)

M. A. Phifer
F. C. Sappington
M. E. Denham

Westinghouse Savannah River Company
Savannah River Site
Aiken SC, 29808

UNCLASSIFIED

DOES NOT CONTAIN
UNCLASSIFIED CONTROLLED
NUCLEAR INFORMATION

ADC &
Reviewing
Official:

DB Mason - Sappington
(Name and Title)

Date:

Mgs. ; 2/26/98

DISCLAIMER

This report was prepared as an account of work sponsored by an agency of the United States Government. Neither the United States Government nor any agency thereof, nor any of their employees, makes any warranty, express or implied, or assumes any legal liability or responsibility for the accuracy, completeness, or usefulness of any information, apparatus, product, or process disclosed, or represents that its use would not infringe privately owned rights. Reference herein to any specific commercial product, process, or service by trade name, trademark, manufacturer, or otherwise does not necessarily constitute or imply its endorsement, recommendation, or favoring by the United States Government or any agency thereof. The views and opinions of authors expressed herein do not necessarily state or reflect those of the United States Government or any agency thereof.

This report has been reproduced directly from the best available copy.

Available to DOE and DOE contractors from the Office of Scientific and Technical Information, P.O. Box 62, Oak Ridge, TN 37831; prices available from (615) 576-8401.

Available to the public from the National Technical Information Service, U.S. Department of Commerce, 5285 Port Royal Road, Springfield, VA 22161.

DISCLAIMER

Portions of this document may be illegible electronic image products. Images are produced from the best available original document.

TNX GEOSIPHON CELL (TGSC-1)

PHASE I

DEPLOYMENT / DEMONSTRATION FINAL REPORT (U)

Prepared by:

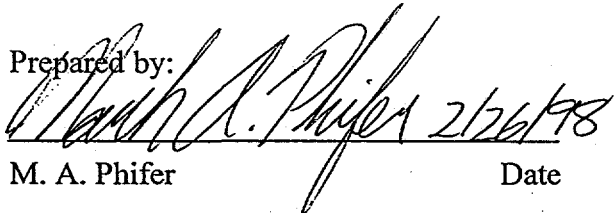
M. A. Phifer

2/26/98
Date

Reviewed by:

R. L. Nichols

2.26.98
Date

Approved by:

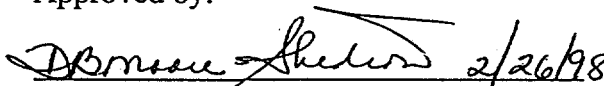
D. B. Moore-Shedrow

2/26/98
Date

Westinghouse Savannah River Company
Savannah River Site
Aiken SC, 29808

Acknowledgments:

Appreciation is expressed to the following Environmental Sciences and Technology Department personnel for their contributions to this work:

- T. R. Jarosch for assistance with chlorinated volatile organic compound data reduction.
- C. J. Berry for chlorinated volatile organic compound and microbial density analyses, and review of the microbial density portions of this report.
- S. E. Aleman for the flow and contaminant transport modeling, and review of the modeling portions of this report.
- C. R. Betivas for sample collection.
- S. L. Baxley for chlorinated volatile organic compound analysis.

TABLE OF CONTENTS

1.0 EXECUTIVE SUMMARY.....	1
2.0 INTRODUCTION.....	5
3.0 BACKGROUND	7
3.1 TNX AREA GROUNDWATER CONTAMINATION DESCRIPTION.....	7
3.2 ZERO VALENT IRONENHANCED ABIOTIC DEGRADATION OVERVIEW	8
3.3 TNX ZERO VALENT IRON LABORATOR STUDY SUMMARY	11
3.4 GEOSIPHON CELL CONCEPT OVERVIEW.....	12
3.5 SIPHON TECHNOLOGY OVERVIEW.....	14
3.6 PHASE I PERMITTING ACTIVITIES OVERVIEW.....	15
4.0 TNX GEOSIPHON CELL (TGSC-1) INSTALLATION AND AS-BUILT CONDITIONS	17
5.0 PHASE I TREATABILITY TESTS	21
5.1 PRELIMINARY PHASE I TREATABILITY ANALYSIS	21
5.2 PHASE I TREATABILITY TEST DESIGN.....	22
5.3 PHASE I TREATABILITY TEST SAMPLING AND SAMPLE ANALYSIS	22
5.3.1 Sampling	22
5.3.2 Sample Analysis.....	26
5.4 PHASE I TREATABILITY TEST DATA ANALYSIS METHOD.....	31
5.5 PHASE I TREATABILITY TEST RESULTS	32
5.5.1 Phase I Treatability Test CVOC Results.....	33
5.5.1.1 Phase I Treatability Test CVOC Data Summary	33
5.5.1.2 Phase I Treatability Test CVOC Data Evaluation.....	38
5.5.1.3 Phase I Treatability Test TCE First Order Rate Constant Determination	43
5.5.1.4 Phase I Treatability Test CVOC Summary	46
5.5.2 Phase I Treatability Test Inorganic Results.....	48
5.5.2.1 Phase I Treatability Test Inorganic Data Summary	48
5.5.2.2 Phase I Treatability Test Inorganic Data Evaluation.....	50
5.5.2.3 Phase I Treatability Test Inorganic Results as Related to Long Term Performance	55
5.5.2.4 Phase I Treatability Test Inorganic Summary	56
5.5.3 Phase I Treatability Test Miscellaneous Results.....	56
5.5.3.1 Phase I Treatability Test Microbial Density Results.....	57
5.5.3.2 Phase I Treatability Test Toxicity Test Results	58
5.5.3.3 Phase I Treatability Test Miscellaneous Results Summary	58

TABLE OF CONTENTS
(continued)

6.0 PHASE I PUMP TEST	61
6.1 PHASE I PUMP TEST DESIGN.....	61
6.2 PHASE I PUMP TEST DATA ANALYSIS METHODS	62
6.3 PHASE I PUMP TEST RESULTS.....	63
6.4 PHASE I PUMP TEST SUMMARY	67
7.0 PRELIMINARY MODELING	69
7.1 PHASE I PRELIMINARY MODEL	69
7.2 PHASE I PRELIMINARY MODELING RESULTS	69
7.3 PHASE I PRELIMINARY MODELING SUMMARY	70
8.0 CONCLUSIONS AND RECOMMENDATIONS	71
REFERENCES	73
FIGURES	75

LIST OF TABLES

Table 1, TNX Flood Plain CVOC Predominant Contaminants.....	8
Table 2, Laboratory Study First Order Rate Constants (k) and Half-Lives ($t_{1/2}$)	12
Table 3, Sample Locations.....	23
Table 4, Analytical Groups	28
Table 5, Analytical Methods and Sample Bottles.....	29
Table 6, Summary Steady State CVOC Data.....	34
Table 7, 8 gpm Steady State Average CVOC Data - GEL Laboratory.....	36
Table 8, Steady State Field Data - ERT	37
Table 9, First Order Rate Constant (k) Summary	44
Table 10, Initial TCE Concentration / Iron Porosity / Average Velocity Comparison	45
Table 11, Summary Steady State Inorganic Data.....	49
Table 12, 8 gpm Steady State Average Indicator Parameters	50
Table 13, Microbial Density Results.....	58
Table 14, TGSC-1 Observation Wells Construction Details	61
Table 15, Aquifer Parameters - Pump Test (AQTESOLV Neuman Method)	64
Table 16, Hydraulic Conductivity - Pump Test	64
Table 17, Estimated TGSC-1 Drawdown	65

LIST OF FIGURES

Figure 1, TNX Location Map.....76

Figure 2, TCE Degradation Series - Column Test Profile77

Figure 3, CT Degradation Series - Column Test Profile.....78

Figure 4, Eh/pH - Column Test Profile.....79

Figure 5, Generic GeoSiphon Cell Conceptualization.....80

Figure 6, TNX GeoSiphon Cell (TGSC-1) Location Map.....81

Figure 7, Soil Boring TCM-1SB and Screen Locations82

Figure 8, TNX GeoSiphon Cell (TGSC-1)83

Figure 9, TNX GeoSiphon Cell SS Sample Tube Location & Designations.....84

Figure 10, GeoSiphon Cell Well Head Details85

Figure 11, TCE Degradation Series - TGSC-1 Profile at 0.97 gpm
(9/30/98 Steady State Data)86

Figure 12, CT Degradation Series - TGSC-1 Profile at 0.97 gpm
(9/30/98 Steady State Data)87

Figure 13, pH - TGSC-1 Profile at 0.97 gpm (9/30/98 Steady State Data)88

Figure 14, TCE Degradation Series - TGSC-1 Profile at 4.00 gpm
(11/11/98 Steady State Data)89

Figure 15, CT Degradation Series - TGSC-1 Profile at 4.00 gpm
(11/11/98 Steady State Data)90

Figure 16, pH / Eh - TGSC-1 Profile at 4.00 gpm (11/11/98 Steady State Data).....91

Figure 17, DO - TGSC-1 Profile at 4.00 gpm (11/11/98 Steady State Data).....92

Figure 18, TCE Degradation Series - TGSC-1 Profile at 7.98 gpm
(12/16/98 Steady State Data)93

Figure 19, CT Degradation Series - TGSC-1 Profile at 7.98 gpm
(12/16/98 Steady State Data).....94

Figure 20, pH / Eh - TGSC-1 Profile at 7.98 gpm (12/16/98 Steady State Data).....95

Figure 21, DO - TGSC-1 Profile at 7.98 gpm (12/16/98 Steady State Data).....96

Figure 22, TCE Degradation Series - TGSC-1 Profile at 7.68 gpm (12/2/98 Data)97

Figure 23, CT Degradation Series - TGSC-1 Profile at 7.68 gpm (12/2/98 Data)98

Figure 24, pH / Eh - TGSC-1 Profile at 7.68 gpm (12/2/98 Data).....99

Figure 25, pH - TGSC-1 Steady State Profiles100

Figure 26, Eh - TGSC-1 Steady State Profiles.....101

Figure 27, TCE Degradation - TGSC-1 Steady State Profiles.....102

Figure 28, cDCE Degradation - TGSC-1 Steady State Profiles.....103

Figure 29, CT Degradation - TGSC-1 Steady State Profiles104

Figure 30, TCM Degradation - TGSC-1 Steady State Profiles.....105

LIST OF FIGURES
(continued)

Figure 31, Flow Rate Versus TCE Discharge Concentration	106
Figure 32, TNX GeoSiphon Cell Velocity Profile.....	107
Figure 33, TCE First Order Rate Constant (k) - Laboratory Column Test	108
Figure 34, TCE First Order Rate Constant (k) - TGSC-1 at 0.97 gpm (9/30/98 Steady State Data)	109
Figure 35, TCE First Order Rate Constant (k) - TGSC-1 at 4.00 gpm (11/11/98 Steady State Data)	110
Figure 36, TCE First Order Rate Constant (k) - TGSC-1 at 7.98 gpm (12/16/98 Steady State Data)	111
Figure 37, TCE First Order Rate Constant (k) - TGSC-1 at 7.68 gpm (12/2/98 Data)	112
Figure 38, Flow Rate (Q) Versus Steady State First Order Rate Constant (k)	113
Figure 39, Flow Rate (Q) Versus Steady Order Rate Constant (k).....	114
Figure 40, Iron - TGSC-1 Profile at Steady State	115
Figure 41, Nitrate - TGSC-1 Profile at Steady State.....	116
Figure 42, Sulfate - TGSC-1 Profile at Steady State	117
Figure 43, Calcium - TGSC-1 Profile at Steady State	118
Figure 44, Magnesium - TGSC-1 Profile at Steady State.....	119
Figure 45, Sodium - TGSC-1 Profile at Steady State	120
Figure 46, Aluminum - TGSC-1 Profile at Steady State	121
Figure 47, Manganese - TGSC-1 Profile at Steady State.....	122
Figure 48, Silica - TGSC-1 Profile at Steady State.....	123
Figure 49, XRD - TGSC-1 Screen Zone Sludge.....	124
Figure 50, XRD - TGSC-1 Discharge Pipe Sludge.....	125
Figure 51, Microbial Density - TGSC-1 Profile at ~7 gpm (1/21/98 Data).....	126
Figure 52, TGSC-1 Hydraulic Response Versus Pumpage & Rainfall.....	127
Figure 53, TCM-2 Time-Drawdown Data Versus Neuman Curve.....	128
Figure 54, TCM-1 Time-Drawdown Data Versus Neuman Curve.....	129
Figure 55, TNX-11D Time-Drawdown Data Versus Neuman Curve	130
Figure 56, TGSC-1Z Time-Drawdown Data Versus Neuman Curve.....	131
Figure 57, TGSC-1 / Savannah River Hydraulic Response.....	132
Figure 58, TGSC-1 / Savannah River Head Difference.....	133
Figure 59, 1997 TCE Profile - Along Line of Wells TNX-8D Through TNX-12D.....	134
Figure 60, Average Modeled TCE Concentration Over Time - At N71250, E16170	135

LIST OF APPENDICES

- Appendix A, TNX GeoSiphon Cell (TGSC-1) As-Builts
- Appendix B-1, 1 gpm Testing - CVOC Data Summary
- Appendix B-2, 1 gpm Steady State CVOC Data Summary - ADS Laboratory
- Appendix B-3, 1 gpm Steady State Inorganic Data Summary - ADS Laboratory
- Appendix B-4, 1 gpm Testing - Field Data Summary
- Appendix B-5, 4 gpm Testing - CVOC Data Summary
- Appendix B-6, 4 gpm Steady State CVOC Data Summary - ADS Laboratory
- Appendix B-7, 4 gpm Steady State Inorganic Data Summary - ADS Laboratory
- Appendix B-8, 4 gpm Testing - Field Data Summary
- Appendix B-9, 8 gpm Testing - CVOC Data Summary
- Appendix B-10, 8 gpm Steady State CVOC Data Summary - ADS Laboratory
- Appendix B-11, 8 gpm Steady State CVOC Data Summary - GEL Laboratory
- Appendix B-12, 8 gpm Steady State Inorganic Data Summary - ADS Laboratory
- Appendix B-13, 8 gpm Steady State Inorganic Data Summary - GEL Laboratory
- Appendix B-14, 8 gpm Testing - Field Data Summary
- Appendix B-15, Steady State CVOC Data Summary
- Appendix B-16, Steady State Inorganic Data Summary
- Appendix B-17, Steady State Field Data Summary
- Appendix C-1, Laboratory Column Test First Order Rate Constant
- Appendix C-2, 1 gpm First Order Rate Constant (9/30/97 Steady State Sampling Event at 0.97 gpm)
- Appendix C-3, 4 gpm First Order Rate Constant (11/11/97 Steady State Sampling Event at 4.00 gpm)
- Appendix C-4, 8 gpm First Order Rate Constant (12/16/97 Steady State Sampling Event at 7.98 gpm)
- Appendix C-5, 7.68 gpm First Order Rate Constant (12/2/97 Sampling Event at 7.68 gpm)
- Appendix D, EnviroMetal Technologies, Inc. (ETI) Long Term Performance Issues Letter
- Appendix E, TNX GeoSiphon Cell Effluent *Ceriodaphnia Dubia* Acute Toxicity Tests
- Appendix F, AQTESOLV Input and Output data

LIST OF ACRONYMS

ADS - WSRC SRTC Analytical Development Section
b - water table aquifer thickness
BOS - bottom of screen
cDCE - cis-1,2-dichloroethylene
C - concentration at time t
C_o - initial concentration
CERCLA - Comprehensive Environmental Response, Compensation, and Liability Act
CM - chloromethane (methyl chloride)
CT - tetrachloromethane (carbon tetrachloride)
CVOCs - chlorinated volatile organic compounds
DCM - dichloromethane (methylene chloride)
DI water - deionized water
DO - dissolved oxygen
DOE - Department of Energy
Eh - oxidation/reduction potential
EMS - WSRC Environmental Monitoring Section
EPA - Environmental Protection Agency
ERD - WSRC Environmental Restoration Department
ERT - WSRC SRTC Environmental Restoration Technology Section
ETI - EnviroMetal Technologies, Inc.
FY - fiscal year
GC-ECD/FID - gas chromatograph with a electron capture detector and a flame ionization detector
GEL - General Engineering Laboratories, Inc.
GC-MSD - gas chromatograph with a mass spectrometer detector
HDPE - high density polyethylene
IC Anion - ion chromatography for Anions
ICP-ES - inductively coupled plasma-emission spectrometry
k - first order rate constant (1/hr)
K_h - horizontal hydraulic conductivity
K_v - vertical hydraulic conductivity
NA - not analyzed
ND - not detected
NPDES - National Pollutant Discharge Elimination System
PCE - tetrachloroethylene
PDWS-MCL - Primary Drinking Water Standard Maximum Contaminant Levels

LIST OF ACRONYMS
(continued)

r - distance from pumping well
RCRA - Resource Conservation and Recovery Act
R&D - research and development
S - storativity
S_y - specific yield
SCDHEC - South Carolina Department of Health and Environmental Control
SRS - Savannah River Site
SRTC - Savannah River Technology Center
SS - stainless steel
T - transmissivity
t - time since reaction began
t_{1/2} - half-life (time required for initial concentration to decrease by one-half)
111-TCA - 1,1,1-trichloroethane
TCE - trichloroethylene
TCM - trichloromethane (chloroform)
TGSC-1 - TNX GeoSiphon Cell #1
TNX - SRTC Semi-Works Facility
TOC - top of casing
TOR - top of riser
TOS - top of screen
VC - chloroethylene (vinyl chloride)
VOA - volatile organic analysis
WSRC - Westinghouse Savannah River Company
WT - water table aquifer
XRD - X-Ray Diffraction
YSI - YSI Model 58 DO meter with Series 5700 oxygen probe

1.0 EXECUTIVE SUMMARY

This report documents the results of the installation of the TNX GeoSiphon Cell and the Phase I testing of the cell. The TNX GeoSiphon Cell (TGSC-1) was installed within the TNX flood plain by auger and caisson methods in July, 1997. The cell was installed to demonstrate treatment of the chlorinated volatile organic compound (CVOC) contaminated groundwater. The predominant CVOC contaminant in the TNX groundwater is trichloroethylene (TCE).

The TNX GeoSiphon Cell is essentially a large diameter well which contains granular cast iron (the treatment media) in place of gravel pack and passively induces flow by use of a siphon from the cell to the Savannah River. The flow is induced by the natural hydraulic head difference between the cell and the Savannah River. The passively induced flow draws contaminated groundwater through the treatment cell where the granular cast iron reduces the CVOCs to ethane, ethene, methane, and chloride ions. The treated water is subsequently discharged to the Savannah River.

During Phase I testing, flow through the TNX GeoSiphon Cell (TGSC-1) was induced by pumping, and the treated water was discharged to the TNX National Pollutant Discharge Elimination System (NPDES) X-08 outfall rather than by siphon directly to the Savannah River. Steady state conditions were created so that field first order rate constants (k) for TCE (i.e. half-lives ($t_{1/2}$)), the associated acceptable treatment flow rates (i.e. flow rates that allow reduction to below Primary Drinking Water Standard Maximum Contaminant Levels (PDWS-MCLs)), and the hydraulic conductivity of the formation within the flood plain (i.e. radius of influence) could be determined.

The following Phase I flow rates through TGSC-1 were utilized:

- 1 gpm from August 5 to September 30, 1997
- 4 gpm from September 30 to November 11, 1997
- 8 gpm beginning on November 11 to December 16, 1997

Results from Phase I testing indicate that the degradation of TCE, itself, is the limiting compound to treatment below the PDWS-MCLs within the TNX GeoSiphon Cell. The data also indicates that a maximum flow rate of between 7.8 gpm and 8.3 gpm can be treated while maintaining the average discharge TCE concentration below 5 ug/l. Additionally the average TCE first order rate constants (k) produced from the steady state TCE data increased with increasing flow from 0.347 /hr at 1 gpm to 0.917 /hr at 8 gpm, and the associated half-lives ($t_{1/2}$) decreased with increasing flow from 2.0 hrs at 1 gpm to 0.76 hrs at 8 gpm.

It was also observed that while the geonet with geotextile may produce a more even distribution of the contaminants over the granular cast iron cylinder surface area than exists within the formation itself, it does not completely average out the formation distribution over the iron surface area (i.e. the contaminant influent profile to the GeoSiphon Cell treatment media is still significantly stratified).

The primary concern associated with the long term performance of granular cast iron treatment systems is that of mineral precipitation. Such precipitation may cause a decline in hydraulic conductivity and porosity over time and may block active CVOC reduction sites on the iron surface. While Phase I testing did not directly address the issue of long term performance, the primary precipitates which are likely to form within the TNX GeoSiphon Cell were identified as pyrite (FeS_2), ferrous iron carbonate (FeCO_3), ferrous iron hydroxide ($\text{Fe}(\text{OH})_2$), and potentially titanite (CaTiSiO_5). These precipitates are similar to those documented in other granular cast iron treatment systems. EnviroMetal Technologies, Inc. indicated that results to date from other granular cast iron treatment systems "indicate that the reactivity of the iron should be maintained for several years to decades, even in areas where precipitates occur."

Two miscellaneous tests were conducted during the Phase I testing. In the first miscellaneous test, microbial densities were determined from water samples taken from selected sampling ports. Microbial densities significantly increased from groundwater levels at the entrance to the GeoSiphon Cell iron treatment zone and then decreased through the rest of the cell, approaching groundwater levels. All microbial densities recorded were comparatively low and are not expected to produce biofouling. In fact the microbes may actually increase the efficiency of the GeoSiphon Cell by scavenging the TCE degradation products such as methane. The second miscellaneous test consisted of two *Ceriodaphnia Dubia*, 48 hour, static, acute toxicity tests of the GeoSiphon Cell effluent. The effluent passed the toxicity tests, indicating that the effluent is not considered toxic.

Additionally during Phase I testing a horizontal hydraulic conductivity (K_h) of approximately 20 ft/day, a horizontal to vertical hydraulic conductivity ratio (K_h/K_v) of approximately 15, a specific yield (S_y) of approximately 0.29, and a storativity (S) of approximately 0.067 were produced from the Phase I hydraulic data. Based upon these average aquifer parameters, the radius of influence of the TNX GeoSiphon Cell was estimated to be approximately 50 ft, 500 ft, and 1000 ft, respectively, for flow rates of 1 gpm, 4 gpm, and 8 gpm (with the radius of influence defined as a drawdown of 0.1 ft after an elapsed time of approximately 70 days).

Also preliminary flow and contaminant transport modeling was conducted to provide an estimate of the maximum TCE contaminant profile in the location of potential full scale GeoSiphon Cell deployment. The preliminary modeling produced maximum TCE concentrations similar to those produced from actual monitoring wells, however the modeled plume width and thickness was significantly wider and thicker than that actually monitored, particularly in the direction of the X-

08 outfall ditch. Additionally the modeling indicated that the current actual concentrations should be the maximum concentrations which a potential full scale GeoSiphon Cell system would have to treat.

Based upon the favorable results to date, the following recommendation are made:

- The Phase II siphon line should be installed and that Phase II testing should be conducted. Phase II testing consists of the induction of flow through the TNX GeoSiphon Cell (TGSC-1) by siphon for direct discharge to the Savannah River. This phase will determine the acceptable siphon flow rates, determine the required cell spacing, and demonstrate the overall concept and functionality. All necessary permitting for installation of the Phase II siphon line has been obtained, and all necessary CERCLA approvals for Phase II testing were obtained at the same time that approval was obtained for Phase I (see section 3.6).
- GeoSiphon Design modifications should be considered to account for the significant influent stratification to the existing GeoSiphon Cell.
- The current TNX flow and contaminant transport model should be modified based upon the measured hydraulic properties of the water table aquifer in the flood plain, the actual TCE concentrations within the plume, and the actual width and thickness of the plume in the flood plain.
- Consideration should be given to additional characterization within the TNX flood plain aimed at defining the actual width of the plume (i.e. additional characterization primarily between monitoring wells TNX-10D and TNX-9D but also between monitoring well TNX-11D and the X-08 outfall ditch).
- Consideration should be given to additional microbial studies within Phase II testing.

2.0 INTRODUCTION

As the result of trichloroethylene (TCE) contamination in the TNX Area water table aquifer at the Savannah River Site (SRS), studies into the applicability of zero valent iron enhanced abiotic degradation of chlorinated volatile organic compounds (CVOCs) to the TNX contaminated groundwater have been conducted. Zero valent iron enhanced abiotic degradation of CVOCs is essentially a reductive dechlorination process, which uses granular cast iron as the reducing agent, and produces final reaction products such as methane, ethane, ethene, and chloride ions in the degradation of TCE. During 1996 a laboratory study was performed to address this applicability, and it was determined that zero valent iron can treat the TNX CVOC contaminated groundwater to below Primary Drinking Water Standard Maximum Contaminant Levels (PDWS-MCL).

The GeoSiphon Cell (patent pending) was conceived as an alternative to pump and treat systems, funnel and gate systems, and/or continuous permeable wall treatment systems for the application of zero valent iron, pursuant to the 1996 laboratory study. The TNX GeoSiphon Cell is essentially a large diameter well which contains granular cast iron (the treatment media) in place of gravel pack and passively induces flow by use of a siphon from the cell to the Savannah River. The flow is induced by the natural hydraulic head difference between the cell and the Savannah River. The passively induced flow draws contaminated groundwater through the treatment cell where the granular cast iron reduces the CVOCs to ethane, ethene, methane, and chloride ions. The treated water is subsequently discharged to the Savannah River.

Based upon the favorable results of the TNX zero valent iron laboratory study and the promising aspects of the GeoSiphon Cell concept, it was decided that a phased approach for GeoSiphon Cell deployment / demonstration would be pursued for remediation of the TNX contaminated groundwater. The phases include the following three phases:

- Phase I deployment / demonstration consists of the following:
 - Installation of a GeoSiphon Cell within the TNX contaminated groundwater in the flood plain.
 - Induction of flow through the cell by pumping, and discharge of the treated water to the TNX National Pollutant Discharge Elimination System (NPDES) X-08 outfall.
 - Creation of steady state conditions so that field first order rate constants (i.e. in situ degradation half lives) for the CVOCs, acceptable treatment flow rates, and the hydraulic conductivity of the formation (i.e. radius of influence) can be determined.

- Phase II deployment / demonstration consists of the following:
 - Induction of flow through the previously installed GeoSiphon Cell(s) by siphon for direct discharge to the Savannah River.
 - This phase will determine the acceptable siphon flow rates, determine the required cell spacing, and demonstrate the overall concept and functionality.

- Phase III full scale deployment, if pursued, will consist of the following:
 - Design, installation, and operation of a full scale GeoSiphon Cell system for treatment of the TNX contaminated groundwater. The design and installation will be based upon the information produced during the previous two phases.

Phase III deployment is contingent upon conformance to the CERCLA requirements for the TNX Groundwater Operable Unit as outlined in the Federal Facility Agreement for the SRS, and approval of a Phase III Industrial Wastewater Treatment Facility Construction Permit Application Package by SCDHEC.

TNX GeoSiphon Phase I deployment / demonstration has been completed. Installation of the first TNX GeoSiphon Cell (TGSC-1) began on July 7, 1997 and was completed on July 17, 1997. Pumping of the cell began on August 5, 1997 and the Phase I deployment / demonstration was completed on December 16, 1997. The Phase I deployment / demonstration is classified as an on-site non-baseline research and development (R&D) performed for the Environmental Restoration Department (ERD).

This TNX GeoSiphon Cell (TGSC-1) Phase I Deployment / Demonstration Final Report provides information on the installation, treatment capability, and hydraulic impact of the TNX GeoSiphon Cell.

3.0 BACKGROUND

3.1 TNX AREA GROUNDWATER CONTAMINATION DESCRIPTION

The TNX Area is a semi-works facility for the Savannah River Technology Center (SRTC), which is located one quarter mile from the Savannah River at the Savannah River Site (SRS) (see Figure 1). TNX is on a terrace above the Savannah River at approximately 150 feet above mean sea level (ft-msl). A portion of the Savannah River flood plain lies immediately west of the TNX Area at 95 to 100 ft-msl. A small levee divides the flood plain and serves as the bank of the river during high stages. Groundwater at TNX can be divided into two main aquifer systems, a shallow and deep aquifer system. The shallow system can be further subdivided into a water table aquifer (35 to 40 feet thick) and a deeper semi-confined aquifer overlain by a clayey silt aquitard. The water table elevation under TNX itself averages 100 ft-msl, under the levee it averages 94 ft-msl, and the Savannah River elevation averages 86. The hydraulic gradients are such that groundwater flows progressively from the deeper aquifers to the shallower aquifers and to the Savannah River. The water table aquifer in the flood plain consists of interbedded sand, silty sand, and relatively thin clay layers. Based upon pump tests, estimates based upon sieve analysis, and 3-D modeling the following aquifer parameters have been estimated for the TNX flood plain water table aquifer:

- Horizontal Hydraulic Conductivity \cong 65 ft/day (2.3E-2 cm/s)
- Vertical Hydraulic Conductivity \cong 30 ft/day (1.1E-2 cm/s)
- Effective Porosity \cong 0.15
- Pore Velocity \cong 3 ft/day (1.1E-3 cm/s)
- Horizontal Gradient \cong 0.007

Groundwater contamination has been detected at TNX in the water table aquifer (TNX Groundwater RCRA/CERCLA Operable Unit), and consistent with the groundwater flow pattern between aquifers, no contamination has been detected in the semi-confined or deep aquifers. The confirmed contaminants present immediately under the TNX facility itself include trichloroethylene (TCE), carbon tetrachloride (CT), tetrachloroethylene (PCE), cis-1,2-dichloroethylene (cDCE), chloroform (TCM), 1,1,1-trichloroethane (111-TCA), nitrate, mercury, and gross alpha radioactivity. Elevated chloroform and 1,1,1-trichloroethane concentrations are confined to beneath the TNX facility itself, and these concentrations are not sufficient to significantly impact the groundwater in the TNX flood plain. Additionally the mercury contamination is confined to one well beneath the TNX facility itself, and does not extend into the TNX flood plain. The predominant contaminants detected in the TNX flood plain are trichloroethylene and nitrate; however carbon tetrachloride, tetrachloroethylene, cis-1,2-dichloroethylene, and gross alpha radioactivity may also exist at detectable concentrations within

the TNX flood plain. Table 1 provides the current TNX flood plain predominant contaminant concentrations from wells TNX-10D and TNX-11D, and TCM-2 and TCM-3. Wells TNX-10D, TNX-11D, and TCM-2 all have 20 foot long screens set across the water table. Well TCM-3 has a 2-½ foot long screen within the water table aquifer.

Table 1
TNX Flood Plain CVOC Predominant Contaminants

Parameter	Units	TNX-10D & 11D Average Concentration ¹	TCM-2 & 3 Average Concentration ²	PDWS MCL
tetrachloroethylene, PCE	ppb	<2.0	2	5
trichloroethylene, TCE	ppb	15.2	200	5
cis 1,2-dichloroethylene, cDCE	ppb	<2.0	32.5	70
chloroethylene, VC (vinyl chloride)	ppb	<2.0	NA	2
tetrachloromethane, CT (carbon tetrachloride)	ppb	<2.0	35.6	5
trichloromethane, TCM (chloroform)	ppb	<3.5	2	100 ³
dichloromethane, DCM (methylene chloride)	ppb	<3.3	NA	5
chloromethane, CM (methyl chloride)	ppb	<2.0	NA	-

Notes: PDWS MCL = Primary Drinking Water Standard Maximum Contaminant Level;
 NA = Not Analyzed

¹ First quarter 1995 through fourth quarter 1995 EMS groundwater monitoring data

² Sampled on 4/30/97 and 5/19-20/97 and analyzed using the ERT headspace method (process data originating from a non-certified laboratory)

³ PDWS-MCL value for trihalomethanes

3.2 ZERO VALENT IRON ENHANCED ABIOTIC DEGRADATION OVERVIEW

Zero valent iron enhanced abiotic degradation of chlorinated volatile organic compounds (CVOCs) is essentially a reductive dechlorination process, which uses granular cast iron as the reducing agent, and produces final reaction products such as methane, ethane, ethene, and chloride ions in the degradation of TCE. This treatment media has been developed and patented by the University of Waterloo and is marketed by EnviroMetal Technologies, Inc. All that is

required for treatment of CVOC contaminated groundwater using this technology is to provide contact time between the contaminated groundwater and the granular cast iron. The exact pathway(s) for this reductive dechlorination process has not yet been fully determined. However it appears that it is a surface activated reaction, which may require the adsorption of the CVOCs onto specific active surface sites on the iron. It has been postulated that the following two competing degradation pathways may exist:

- Step-wise dechlorination pathway
- Multiple dechlorination pathway

Following the step-wise dechlorination pathway, it is postulated that the iron is oxidized, water dissociates to form hydrogen ions and gas, and the chlorine on the CVOCs are replaced with hydrogen (CVOCs reduced) in a step-wise fashion. In this pathway trichloroethylene (TCE) degrades to cis-1,2-dichloroethylene (cDCE), cDCE in turn degrades to vinyl chloride (VC), and VC subsequently degrades to ethene, ethane, and methane. Following the multiple dechlorination pathway, it is postulated that the iron is oxidized, TCE degrades to chloroacetylene with the removal of two chlorines (reduced), chloroacetylene degrades to acetylene with the removal of one chlorine (reduced), and acetylene finally degrades to ethene, ethane, and methane. The chloroacetylene and acetylene under these conditions are very unstable and degrade rapidly, therefore it is difficult to monitor their presence.

Since these two pathways compete, the mass of cDCE and VC intermediates is substantially less than the original TCE mass. It has been typically observed that zero valent iron degradation of TCE and PCE produces a mass of the intermediates cDCE and VC at approximately 20% and 2%, respectively, of the original TCE and PCE mass. These intermediate reaction products are subsequently degraded. It is assumed that the remainder of the original TCE and PCE mass proceeds through the multiple dechlorination pathway (chloroacetylene/acetylene).

It has been typically observed that zero valent iron degradation of carbon tetrachloride (CT) produces a mass of the intermediate chloroform (TCM) at approximately 20% of the original CT mass. It has also been typically observed that degradation of carbon tetrachloride (CT) produces a combined mass of methylene chloride (DCM) and methyl chloride (CM) at approximately 4% of the original CT mass. TCM is subsequently degraded, but DCM and CM are not degraded by the zero valent iron process.

During this treatment process, the Eh (oxidation/reduction potential) decreases (that is, reducing conditions are produced) and the pH increases. This treatment process may be dependent upon pH, it may be inhibited by elevated nitrate levels, and it may reach a dichloromethane and chloromethane endpoint in the degradation of carbon tetrachloride (CT). Zero valent iron degradation of CVOCs is best described by the first order kinetic model:

$$\ln (C/C_0) = -kt$$

where: k = first order rate constant (1/hr)
 t = time since reaction began
 C = concentration at time t
 C₀ = initial concentration,

$$t_{1/2} = 0.693/k$$

where: t_{1/2} = half-life (time required for initial concentration to decrease by one-half)
 k = first order rate constant (1/hr)

The following is the generic chemical reaction:

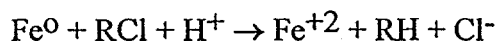

R = generic organic molecule

The following is the generic TCE reaction (the equations are not balanced):

Initial TCE Contamination:



↓

Intermediate Reaction Products:

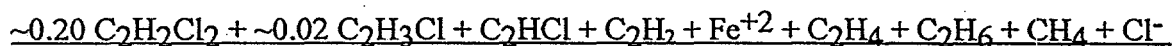

↓

Final Reaction Products:

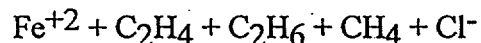

Reaction Notes: TCE = C₂HCl₃ ; cDCE = C₂H₂Cl₂ ; VC = C₂H₃Cl ;
 chloroacetylene = C₂HCl ; acetylene = C₂H₂ ; ethene = C₂H₄ ; ethane = C₂H₆ ;
 methane = CH₄

Several full scale commercial applications of zero valent iron enhanced abiotic degradation (granular cast iron) of chlorinated volatile organic compounds (CVOCs) have been implemented in either funnel and gate or continuous permeable wall applications as outlined in EPA/600/F-97/008.

[Gillham and O'Hannesin, 1994; ETI Ref.: 31054.10; SRT-ESS-96-365; Tratnyek, et. al., 1997; EPA/600/F-97/008; O'Hannesin and Gillham, 1998]

3.3 TNX ZERO VALENT IRON LABORATORY STUDY SUMMARY

During 1996 a laboratory study was performed to address the applicability of zero valent iron enhanced abiotic degradation (granular cast iron) to the TNX groundwater contamination. Both batch and column tests were performed utilizing iron and iron/pyrite reactive media. Two flow rates were utilized in the column tests with TNX contaminated groundwater samples from wells TNX-10D and TRW-1. Figures 2 and 3 present the steady state degradation profiles for TCE and cDCE, and CT and TCM, respectively, through the 100% granular cast iron column utilizing TNX groundwater from well TRW-1. Figure 4 presents the pH and Eh (oxidation/reduction potential) profile through the 100% granular cast iron column utilizing TNX groundwater from well TRW-1. The following observations and conclusions were drawn from the laboratory study:

- Zero valent iron can treat the CVOC contaminated groundwater in the TNX flood plain to below Primary Drinking Water Standards Maximum Contaminant Levels (PDWS-MCL), while producing less toxic final degradation products such as ethane, ethene, and methane.
- Approximately 20 percent of the trichloroethylene (TCE) and tetrachloroethylene (PCE) mass appears in solution as the intermediate degradation product cis 1,2-dichloroethylene (cDCE) and approximately 2 percent appears as vinyl chloride (VC). The cDCE and VC subsequently degrade to ethane, ethene, and methane along with the remainder of the TCE and PCE.
- Approximately 10 percent of the carbon tetrachloride (CT) mass appears in solution as the intermediate degradation product chloroform (TCM). This is less than the typically observed 20% production rate seen in other studies. The TCM subsequently degrades to ethane, ethene, and methane along with the remainder of the TCE.
- The Eh (oxidation/reduction potential) decreases (that is, reducing conditions are produced) and the pH increases through the granular cast iron.
- A 100 percent iron reactive medium should be utilized. The iron/pyrite reactive medium was tested to determine if it could decrease the half-lives by maintaining a lower pH; this was determined to not be the case.
- The CVOC degradation process will proceed under the nitrate conditions that exist at TNX. In fact the nitrates are reduced to ammonium and possibly nitrogen by the zero valent iron process.
- CVOC half lives appear to be influenced by the following:
 - Temperature: as temperature decreases, the half life of the CVOCs decreases.
 - Nitrate concentration: as nitrate levels increase, the half life of the CVOCs may decrease.
 - Velocity: as the flow-through velocity increases, the half life of the CVOCs may increase up to a point.

- Neither chemical precipitation nor biofouling appear to be significant problems relative to plugging the pore space, based upon this study. The precipitates determined to be most likely to form during this treatment process are iron and aluminum hydroxides, and iron and calcium carbonates. The iron and aluminum hydroxides are most likely to precipitate after the groundwater leaves the iron treatment zone and enters the receiving waters, where the aquifer tends to reduce the pH and increase the Eh. The iron and calcium carbonates are most likely to precipitate within the iron treatment zone, where the pH is elevated (~9).
- Table 2 provides a summary of the first order rate constants (k) and half lives ($t_{1/2}$) generated from the chemical analyses data at steady state.

Table 2
Laboratory Study Results
100% Iron Reactive Medium with Well TRW-1 Groundwater
First Order Rate Constants (k) and Half-Lives ($t_{1/2}$)

Parameter	Initial Conc. ($\mu\text{g/L}$)	Rate Constant, k (1/hr)	Half-Life, $t_{1/2}$ (hrs)
PCE	15	1.732	0.40
TCE	161	1.873	0.37
cDCE	19	0.289	2.4
VC*	nd	0.173	4
CT*	11	6.93	0.10
TCM*	0.3	0.58	1.2
DCM*	nd	0	∞
CM*	nd	0	∞

Notes:

nd = not detected.

* Data based upon previous column tests conducted by the University of Waterloo

[ETI Ref.: 31054.10; SRT-ESS-96-365]

3.4 GEOSIPHON CELL CONCEPT OVERVIEW

The GeoSiphon Cell (patent pending) was conceived as an alternative to pump and treat systems, funnel and gate systems, and/or continuous permeable wall treatment systems, pursuant to the zero valent iron laboratory study conducted in 1996 on the TNX contaminated groundwater. The GeoSiphon Cell combines the existing proven technologies of permeable treatment media and a

siphon to produce a passive in situ groundwater treatment system, which while essentially proven, is also innovative and unique. Figure 5 provides a generic conceptualization of a GeoSiphon Cell. GeoSiphon Cells are systems designed to passively induce contaminated groundwater flow through in situ permeable treatment media at an accelerated rate by utilizing the natural hydraulic head difference between two points. The accelerated passively induced flow is produced through the use of a siphon between the points of natural head difference. The up gradient initiation point is within a contaminated aquifer, and the down gradient discharge point can be to the subsurface, a surface water body, or the ground surface. The permeable treatment media utilized in GeoSiphon Cells can include granular cast iron, activated carbon, cation exchange resin, limestone, zeolites, etc. The permeable treatment media can be applied at any point in the passively induced flow, can be applied as in situ or ex situ, and can be configured to be either permanent or rechargeable.

Groundwater pump and treat systems consist of recovery wells which extract contaminated groundwater from the subsurface at greater than natural groundwater flow rates for treatment in above grade treatment systems. The use of groundwater pump and treat systems for the remediation of groundwater contamination has increasingly received unfavorable evaluations due to the extended periods that such systems must operate in order to reduce the contaminant levels to below that required by the regulatory agencies. These extended periods of operation result from the fact that pump and treat systems generally require the contaminants to be in the aqueous phase in order for them to be extracted from the subsurface and treated. For many of the contaminants only a fraction of the total mass is in the aqueous phase; a significant fraction of the mass may exist in another phase due to partitioning, adsorption/absorption, precipitation, solubility, etc. The mass of contaminants in these other phases can be subsequently slowly released to the aqueous phase as remediation proceeds. This slow release requires that multiple groundwater pore volumes be extracted and treated in order to reach regulatory standards. This in turn requires that the pump and treat system be operated for extended periods, with their associated high energy, operating, and maintenance costs, which results in their unfavorable evaluation.

In order to overcome the high operating and maintenance costs of pump and treat systems, funnel and gate and continuous permeable wall treatment systems have been proposed and implemented. Funnel and gate systems consist of impermeable barriers which funnel the contaminated groundwater through a permeable treatment gate consisting of permeable treatment media. Continuous permeable wall systems consist of a continuous bed of permeable treatment media which intersects the entire plume perpendicular to the direction of flow.

These are passive, in situ systems which also generally require that the contaminant exist in the aqueous phase for treatment but rely on the natural groundwater flow rates to flush contaminants through permeable treatment media. Since contaminants exist in multiple phases regardless of the remediation systems utilized, and since these systems rely on the natural groundwater flow

rates, the actual duration required to achieve treatment with these systems can be significantly greater than that for pump and treat systems. However these systems achieve remediation with minimal operating and maintenance costs relative to pump and treat.

The GeoSiphon Cell for the remediation of contaminated groundwater is an innovative and unique alternative to current technologies (pump and treat, funnel and gate, continuous permeable wall). GeoSiphon Cells have many of the advantages of the current technologies without most of the disadvantages. GeoSiphon Cells utilize natural hydraulic driving forces to induce accelerated flow rates (greater than natural) for remediation similar to conventional pump and treat systems, but improve upon them through an in situ configuration, passive operation (no external power requirements), and significantly lower operating and maintenance cost. The passive operation of GeoSiphon Cells is similar to funnel and gate and continuous permeable wall treatment systems, but it should have the following advantages:

- less initial cost
- less land disturbance
- it uses existing foundation installation and/or well drilling techniques
- can induce flow greater than the natural groundwater flow (i.e. accelerate clean up)
- reduce the potential for pluggage problems due to mineral precipitation.

GeoSiphon Cells can minimize the operating and maintenance costs associated with pump and treat systems, and at the same time minimize the time required for remediation associated with funnel and gate or continuous permeable wall treatment systems.

3.5 SIPHON TECHNOLOGY OVERVIEW

A siphon is a closed conduit which passively (i.e., no power input) conveys liquid from a point of higher hydraulic head to one of lower head after raising it to a higher intermediate elevation which is at sub-atmospheric conditions (negative pressures). In other words a siphon is essentially a passive vacuum pump. A siphon has a maximum theoretical lift of 34 feet (equivalent to atmospheric pressure); however it has a maximum practical lift of 25 feet due to the vapor pressure of water and friction head loss. Accumulation of air can break the siphon; however this can be avoided by maintaining a minimum flow velocity to facilitate air removal, use of air chambers at the siphon crest, use of a submerged outlet, and maintaining full flow in the siphon. Siphons require priming (initial filling of line) to initiate flow. This can be accomplished by gravity filling from high points with the inlet and outlet valved off, use of a vacuum pump at the outlet, or use of a vacuum pump or submersible pump at the inlet. After priming, the siphon will passively convey liquid from the point of higher hydraulic head to the one of lower head indefinitely so long as the head differential is maintained and the prime is not lost. Siphons are utilized in standard industrial and water resource applications. In fact siphon well systems have been utilized in Florida for the dewatering of water table aquifers. This

dewatering application is similar to the GeoSiphon Cell described below; however the GeoSiphon Cell not only dewater, but it provides groundwater treatment.

[Gibson, 1961; Edwards, 1984; Loitz, et. al., 1990; Mathur, 1990]

3.6 PHASE I PERMITTING ACTIVITIES OVERVIEW

The following is a summary of the permitting conducted for installation and operation of the TNX GeoSiphon Cell during Phase I of the demonstration:

- Letter, Donald L Siron to J. W. Cook, dated January 9, 1997, transmitted Approval # SF-97-0002 for the installation of two (2) GeoSiphon Cells designated TGSC-1 and TGSC-2.
- Letter, Melinda G. Vickers to W. L. Payne, dated January 16, 1997, provided approval for operation of the TNX GeoSiphon Cells for a period not to exceed 6 months from the date of startup with the wastewater being discharged to the X-008 outfall.
- Letter, Harriet H. Gilkerson to J. W. Cook, dated March 14, 1997, accepting final TNX GeoSiphon Cell design as deviating minimally from the initial submittal; therefore changes to the original approval dated January 9, 1997 (Siron to Cook) were not required.
- Letter, W. L. Payne to M. G. Vickers, dated May 21, 1997, outlining agreement that the TNX GeoSiphon Cell effluent for cis-1,2-dichloroethylene could be revised from <5 ppb to <70 ppb for the previously approved operation approval.
- Letter, Brian T. Hennessey to K. A. Collinsworth and J. L. Crane, dated June 26, 1997, outlining agreement that the GeoSiphon Cell demonstration would be conducted in the TNX area and that this technology will be discussed in the CMS/FS for the TNX Area Operable Unit and the result of the test will be documented in a separate Treatability Study Report.
- Letter, Harriet H. Gilkerson to J. W. Cook, dated August 25, 1997, provided approval for installation of a replacement sampling tube TGSC-1A for the TNX GeoSiphon Cell (TGSC-1A).

4.0 TNX GEOSIPHON CELL (TGSC-1) INSTALLATION AND AS-BUILT CONDITIONS

The TNX GeoSiphon Cell is essentially a large diameter well which contains granular cast iron in place of gravel pack. Installation of the TNX GeoSiphon Cell (TGSC-1) by auger and removable caisson method within the TNX flood plain began on July 7, 1997 and was completed on July 17, 1997. The following provides pertinent information regarding equipment and materials associated with the cell fabrication and installation:

- The following heavy equipment was utilized for the installation:
 - Grove 100 ton hydraulic crane
 - HPSI 260 vibratory driver/extractor and power pack
 - Texoma 700 foundation drilling machine with
 - * 8' diameter double flight dirt auger with flaps
 - * 6' diameter double flight dirt auger
 - Flat bed truck (for material handling)
 - Case 585E rubber tire fork lift (for material handling)
 - 102" diameter, 5/8" thick, 25' feet long casing

- The GeoSiphon Cell Cage was fabricated at the subcontractor's fabrication facility and was installed as a complete unit. The following are the primary components of the cage:
 - 8' diameter, 1/2" thick base plate
 - 32 # 14 vertical reinforcing bars, 20'-4" long
 - 32 # 6 horizontal reinforcing bars, 96" diameter
 - 9 - 1/4" stainless steel sampling ports 12'-9" long
 - 1 - 12" diameter stainless steel casing and screen total length 23'-3"
 - 1 - 2" PVC monitoring well casing and screen total length 13'-5"
 - The cage was wrapped with:
 - * bottom 14'-9" Geonet with Geotextile
 - * top 5'-8" multiple wraps of a polyethylene sheeting

- The following materials were installed in the field after field placement of the cage:
 - 49.7 tons of iron filings in 1-2 ton bulk bags
 - 900 pounds of bentonite pellets
 - 7.5 cubic yards of lean fill

– 3 cubic yards of concrete for concrete pad and barricade post

- The following is chronological outline of the cell fabrication and installation:

– Day 1: Mobilization activities began with the arrival of equipment and materials, and placement of mud mats.

– Day 2: Work started with the installation of hay bales and silt fence. The 102" diameter casing arrived at the site at mid morning. The 100 ton crane arrived at the site at 11:30 and was in place at an hour later. Following the crane set up, the casing was off loaded. The 16 ton vibratory driver/extractor and power pack reached the general site area mid afternoon and was assembled. Casing installation started at 16:30. Within 40 minutes the casing had been driven to a depth of 12'. Over the course of the next 35 minutes the casing had reached refusal at a depth of 12'-6". Work was stopped for the day. Iron cemented sand nodules were identified at a depth of about from 10' to 12'-6" below grade, accounting for the difficulty in the last few feet of today's casing installation.

– Day 3: The crew began the day setting up the auger Texoma rig. The decision had been made to cut off the casing to allow for the Texoma rig to gain access to the inside of the casing. 7'-6" of the casing was cut off and placed aside. This left 5' of stick up, which allowed sufficient clearance to begin augering with the 8' diameter auger bit. Augering ceased at 12'-6" at which time the casing was driven to a depth of 15'. The 6' diameter auger bit was installed on the Texoma rig and augering continued to a depth of 2-3' below the elevation of the casing bottom. The casing was then driven down to a depth of 16'-6", leaving 1' of stick up to allow rewelding of the cut off section to the rest of the casing. The hole was tagged at a depth of 13' and it was noted that sands were flowing into the hole. Rewelding of the cut off section of the casing took approximately 4 hours. The casing was driven in far enough to again allow access by the Texoma rig. The Texoma rig was set up and augering continued with the 6' diameter auger bit. The auger was removed and the casing driven to the Top of Casing target elevation of 101'. The hole was tagged at 18'-6" from the top of casing. Work was stopped for the day at 17:43.

– Day 4: The water level in the bore hole was 14' below the top of the casing. The soil level was 18' below the top of the casing. A pump was set up and the water pumped out to within 6" of the top of the soil. Augering with the 8' diameter auger bit restarted at 18'. Augering continued to a depth of 24' below the top of the casing. Gray clay was noted at 21' and variable orange and gray clay layered soil at 23'-6". The auger was reversed at the bottom of the excavation to smooth the bottom and then removed. The bottom was tagged at 23'-8" soft and 24'-2" solid. Sand and water flowing in from east side were also noted. The decision was made to put a head on the excavation. 4000 gallons of water (to a

level 11' below the top of the casing) was placed in the casing to stop the flowing sands. All equipment was removed from the casing. The Texoma rig again began augering starting at 23'-3" from the top of the casing down to 24'. The material removed was light tan sand that flowed in prior to the head being placed on the bore hole. As the crane was being rigged for the GeoSiphon Cell cage lift, the fines in the water were allowed to settle. One hour after the Texoma rig had been removed from the bore hole the GeoSiphon Cell cage was lifted to vertical position and lowered into place inside the augered out casing. Installation of the bulk bags of iron started immediately after. The installation of the iron took approximately 2 hours and was stopped briefly only once to allow the pumping of water from the hole. The final depth of the filings was 8'-8" to 8'-10" from the top of the casing on the south side and 9'-2" to 9'-4" from the top of the casing on the north side. HDPE sheeting was placed on top of the iron. The bentonite pellet placement followed with the placement of 900 pounds of bentonite for a minimum depth of 1' across the entire opening. Clean up activities started in preparation for removal of the casing. The casing was removed from the ground with the vibratory driver/extractor in 8 minutes. Sandy soil then placed in an annulus space observed on the south and east side of cell. At 17:00 work was stopped for the day.

– Day 5: Clean up activities started first thing in the morning. This included the rough grading. The lean fill arrived at the site at 9:30. The lean fill was placed into the remaining 4' of the cell to bring the cell to grade. Demobilization activities started mid morning and continued through the remainder of the day

– Day 6: Demobilization activities continued. The reinforcing mat was placed for the concrete pad and the post holes were excavated for the barricade posts. Concrete placement for the pad and barricade posts started at 11:20 and was completed in an hour. Final grading/site restoration was complete at 14:00.

Figures 1 and 6 provide the as-built location of TGSC-1 relative to the TNX Area, the Savannah River, and existing monitoring wells. Figure 7 provides the as-built location of the granular cast iron treatment zone of TGSC-1 relative to the TCE soil contaminant profile, the soil type, and the screen zones of adjacent monitoring wells. As shown in Figure 7 the TCE contamination is highly stratified with the bulk of the contamination at the top of the aquifer. Figures 8, 9, and 10 provide generalized as-built conditions of TGSC-1 as set up for the Phase I deployment / demonstration. As shown in Figures 1 and 10 a 1-½ inch HDPE pipe was utilized to route the treated groundwater to the existing NPDES X-08 outfall for discharge. The piping to the X-08 outfall will be removed prior to Phase II testing. The actual as-builts of the TNX GeoSiphon Cell (TGSC-1) are provided in Appendix A. As shown in the as-builts the cell consists of the following major components with the functions as listed:

- A geonet with a geotextile bonded to both sides has been placed between the soil and the granular cast iron. This geonet with geotextile performs the following functions:
 - The geotextile acts as a filter preventing migration of soil particles into the granular cast iron and preventing pluggage of the geonet.
 - The geonet has a high planar transmissivity. This high planar transmissivity, which is vertically oriented, should provide a more even distribution of head and flow with depth and subsequently a more even distribution of the contaminants over the granular cast iron cylinder surface area than exists within the formation itself. This should minimize short circuiting of elevated formation contaminant layers through the granular cast iron.
- A steel plate and a high density polyethylene (HDPE) membrane has been placed below and above the granular cast iron, respectively, to promote horizontal flow through the granular cast iron and prevent short circuiting of the contaminated groundwater.
- A 12 inch diameter screen and casing has been placed in the center of the granular cast iron cylinder to allow insertion of the siphon line and withdrawal of the treated groundwater.
- The granular cast iron treats the CVOCs by the process of zero valent iron enhanced abiotic degradation as described above. Due to the geometry of the GeoSiphon Cell, flow through the iron is horizontal, radially inward flow with an increasing velocity from the geonet with geotextile exterior to the 12 inch diameter screen interior. Approximately 49.7 tons of 0.25 to 2.0 mm (particle size) granular cast iron have been utilized in TGSC-1. The as-built granular cast iron porosity is 0.68. The as-built granular cast iron treatment zone extends from a radius of 0.53 to 4.0 feet.
- The bentonite seal and lean fill has been placed to prevent surface infiltration into the GeoSiphon Cell and to bring the cell to grade.
- 9 ¼ inch stainless Steel sampling ports allow collection of samples along one horizontal, radial flow path (see Figure 9).

5.0 PHASE I TREATABILITY TESTS

5.1 PRELIMINARY PHASE I TREATABILITY ANALYSIS

The anticipated required residence time to achieve degradation (i.e. below Primary Drinking Water Standard Maximum Contaminant Levels (PDWS-MCLs); see Table 1), the required average velocity through the GeoSiphon Cell to provide the required residence time, and the maximum flow rate through the GeoSiphon Cell that produces the required average velocity were estimated prior to initiation of testing based upon the following:

- Contaminant levels of 210 ppb, 40 ppb, and 55 ppb, respectively for TCE, cDCE, and CT.
- First order kinetic model: $\ln(C/C_0) = -kt$.
- First order rate constants (k) as presented in Table 2.
- Degradation of trichloroethylene (TCE) and tetrachloroethylene (PCE) produces a mass of the intermediates cis-1,2-dichloroethylene (cDCE) and vinyl chloride (VC) at approximately 20% and 2%, respectively, of the original TCE and PCE mass.
- Degradation of carbon tetrachloride (CT) produces a mass of the intermediate chloroform (TCM) at approximately 20% of the original CT mass. Degradation of carbon tetrachloride (CT) also produces a combined mass of methylene chloride (DCM) and methyl chloride (CM) at approximately 4% of the original CT mass.
- Granular cast iron radius within TGSC-1 from 0.53 to 3.92 feet.
- Granular cast iron porosity of 0.40 (this estimation was performed prior to having the as-built porosity of the finished TNX GeoSiphon Cell).
- Radial flow through TGSC-1 with an increasing velocity toward the center.

Based upon the above assumptions the following estimates were produced:

- Anticipated required residence time \cong 380 minutes
- Required average velocity \cong 0.0089 ft/min
- Maximum flow rate \cong 4 gpm (produces average velocity of 0.0087 ft/min)
- By this estimate the production and subsequent degradation of the intermediate, vinyl chloride (VC), was shown to be the limiting reaction.

In order to assure that the discharge did not exceed the applicable PDWS-MCLs (see Table 1), an initial flow rate of 1 gpm was chosen. The flow rate was increased as treatment was adequately demonstrated and field half-lives determined.

5.2 PHASE I TREATABILITY TEST DESIGN

During Phase I deployment / demonstration flow through the TNX GeoSiphon Cell (TGSC-1) was induced by pumping, and the treated water was discharged to the TNX National Pollutant Discharge Elimination System (NPDES) X-08 outfall (see Figure 1). An initial flow rate of 1 gpm was utilized based upon pre-test estimates in order to assure that the discharge from TGSC-1 was below the applicable PDWS-MCLs (see Table 1). CVOC degradation through the granular cast iron was monitored along one horizontal, radial flow path using a series of stainless steel (SS) sampling tube locations (see Figures 8 and 9). Discharge concentrations were determined from a sampling port on the discharge line and from the end of the discharge line at the NPDES X-08 outfall for comparison to the PDWS-MCLs (see Figure 10 for the cell head details). Steady state conditions were created so that field first order rate constants (k) for the CVOCs and the associated acceptable treatment flow rates (i.e. flow rates that allow reduction to below PDWS-MCLs) could be determined. The flow rate was increased as treatment was adequately demonstrated and as higher flow rates were shown to be acceptable versus reduction to the PDWS-MCLs.

The following major equipment was utilized and set up per Figure 10 for Phase I deployment / demonstration:

- Grundfos 10S05-9 (½ HP, 1 phase, 230 volts, 3-wire) submersible pump
- One Fischer & Porter magnetic flow meter
- The magnetic flow meter will be installed on the discharge piping.

5.3 PHASE I TREATABILITY TEST SAMPLING AND SAMPLE ANALYSIS

Groundwater contaminant degradation through the granular cast iron was monitored along one horizontal, radial flow path using a series of SS sampling tube locations (see Figures 8 and 9). Discharge concentrations were determined from a sampling port on the discharge line and from the end of the discharge line at the NPDES X-08 outfall for comparison to the PDWS-MCLs (see Figure 10 for the cell head details). Steady state conditions were created so that field first order rate constants (k) for the CVOCs and the associated acceptable treatment flow rates (i.e. flow rates that allow reduction to below PDWS-MCLs) could be determined. The flow rates were increased as treatment was adequately demonstrated and as higher flow rates were shown to be acceptable versus reduction to the PDWS-MCLs.

5.3.1 Sampling

Pre-test sampling of the SS sampling tubes (see Figure 9) and analysis for analytical group 1 (see Table 4) was conducted as a baseline.

At each flow rate utilized, periodic sampling of the SS sampling tubes (TGSC-1A through TGSC-1I), the TGSC-1 discharge sample port (TGSC-1S), the end of the discharge line at the NPDES X-08 outfall (TGSC-X8), monitoring well TCM-2 (assumed to represent the average influent to the GeoSiphon Cell) was conducted (see Figures 1, 6, 8, 9, and 10). Table 3 provides the relationship between each sample location and the granular cast iron treatment media.

Table 3
Sample Locations

Sample Port / Well	Distance into Iron Bed (ft)	Location	Comments
TCM-2	0	Influent	~25 ft upgradient ¹
TGSC-1A	0	Influent	Immediately upgradient ²
TGSC-1B	0.14	Within iron	2
TGSC-1C	0.32	Within iron	2
TGSC-1D	0.64	Within iron	2
TGSC-1E	1.07	Within iron	2
TGSC-1F	1.50	Within iron	2
TGSC-1G	2.04	Within iron	2
TGSC-1H	2.86	Within iron	2
TGSC-1I	3.47	Effluent	Immediately downgradient ³
TGSC-1S	-	Effluent	At well head ⁴
TGSC-X8	-	Effluent	At X-08 outfall ⁴

¹ TCM-2 is screened over the entire GeoSiphon treatment zone depth; samples from it therefore should represent the average influent to the GeoSiphon.

² Sample ports TGSC-1A through TGSC-1H are stainless steel tubes with three inch screen zones all at one elevation; samples from them therefore should represent the concentrations along one horizontal, radial, flow path.

³ TGSC-1I is a stainless steel tube with a three inch screen attached to the inside of the 12 inch central screen at the same elevation as TGSC-1A through TGSC-1H; however due to its location within the 12 inch screen, it probably does not represent concentrations along the one horizontal, radial, flow path of the other sample ports, but it represents more closely the average discharge from the GeoSiphon.

⁴ TGSC-1S and TGSC-X8 are located on the 1-½ inch HDPE discharge line and receive treated groundwater from the entire 14 foot long 12 inch GeoSiphon central screen; samples from them therefore represent the average effluent from the GeoSiphon.

The SS sampling tubes (TGSC-1A through TGSC-1I; see Figures 8 and 9) consist of ¼ inch OD SS tubing (0.049 inch wall thickness) perforated as shown in Figure 9. A 1/8 inch OD, 1/16 inch ID nylon tube has been inserted into the SS tubing to within ~3 inch of the bottom of the SS tubing, and the nylon tubing extends above the top of the SS tubing. A small section of Tygon tubing (¼ inch OD, 1/8 inch ID) with a tubing clamp connects the nylon tubing with a dedicated 50 ml gas tight glass syringe, which was used to collect the samples. Sampling of these tubes was conducted as follows:

- The syringe was rinsed with DI water and allowed to dry prior to sampling event.
- The syringe plunger was pushed all the way down.
- The 50 ml gas tight glass syringe was connected to the Tygon tubing.
- The tubing clamp on the Tygon tubing was released.
- The syringe plunger was slowly and gently pulled back so that approximately 20 ml of liquid was taken into the syringe (this purge was conducted to clear the nylon/SS tubing of stagnant water prior to actual sampling).
- The tubing clamp on the Tygon tubing was closed.
- The 50 ml syringe was disconnected from the Tygon tubing while the liquid in the Tygon tubing was maintained (wanted to minimize air in the system to prevent volatilization of the organics).
- The syringe was pointed upward and slowly and gently the air and liquid in the syringe was discharged by pushing the plunger all the way down so that all air was eliminated from the syringe and the liquid was maintained in the tip of the syringe (the purge liquid was maintained in a carboy for proper disposition).
- The syringe was reconnected to the Tygon tubing in a manner that minimized air in the tubing and syringe.
- The tubing clamp was released from the Tygon tubing.
- The syringe plunger was slowly and gently pulled back so that the required sample volume up to 50 ml in the syringe was obtained.
- The tubing clamp on the Tygon tubing was closed.
- The syringe was disconnected from the Tygon tubing while maintaining the liquid in the Tygon tubing (wanted to minimize air in the system to prevent volatilization of the organics).
- The sample was slowly and gently discharged into the appropriate sample bottle in a manner that minimized contact with air (minimized splashing) and the sample bottle was immediately capped.
- The syringe was rinsed with DI water after each sampling event.

Samples from the TGSC-1 ¼ inch discharge sample port (TGSC-1S; see Figure 10), which is within the discharge line, were taken by placing the appropriate sample bottle below the ¼ inch nipple and opening the ¼ inch ball valve so that the sample flowed into the bottle. The sample was collected in a manner that minimized contact with air (minimized splashing) and the bottle was immediately

capped after the sample had been collected.

Samples from the TGSC-1 1-½ inch HDPE discharge pipe to the NPDES X-08 outfall (TGSC-X8; see Figure 10) were taken by placing the appropriate sample bottle below the discharge pipe so that the sample flowed into the bottle. The sample was collected in a manner that minimized contact with air (minimized splashing) and the bottle was immediately capped after the sample had been collected.

Samples from monitoring well TCM-2 (see Figure 6 for location) were taken utilizing a dedicated Grundfos Redi-Flo II submersible pump. One well volume of water was evacuated (the evacuated water was contained for proper disposition) prior to obtaining a sample. The sample was collected in an appropriate sample bottle from the discharge tubing, after the flow rate had been reduced so that splashing and contact with air was minimized. The bottle was immediately capped after the sample had been collected.

A one time sample method comparison was conducted on December 2, 1997 utilizing monitoring well TCM-2 for the comparison of the following sample methods:

- Use of a plastic syringe (PL) for collection of a sample through the ¼ inch SS tube sample ports utilized for sample ports TGSC-1A through TGSC-1I
- Use of the glass syringe while pulling quickly on the plunger (GF) for collection of a sample through the ¼ inch SS tube sample ports utilized for sample ports TGSC-1A through TGSC-1I
- Use of the glass syringe while pulling slowly on the plunger (GS) for collection of a sample through the ¼ inch SS tube sample ports utilized for sample ports TGSC-1A through TGSC-1I
- Pumping with a Grundfos Redi-Flo II submersible pump (PMP)

The following are the results of this evaluation:

<u>Sample Method</u>	<u>TCE</u>	<u>cDCE</u>	<u>CT</u>	<u>TCM</u>
Plastic syringe	213.3	39.0	27.0	3.9
Glass syringe (fast)	219.6	40.8	27.5	4.1
Glass syringe (slow)	208.1	38.0	27.2	3.9
Pump	216.9	38.7	26.0	4.0

All of the above samples were analyzed by the ERT laboratory using the headspace method and a gas chromatograph with a electron capture detector and a flame ionization detector. All sampling

methods provided results within 5 to 7 percent of each other, and are therefore considered essentially equivalent.

5.3.2 Sample Analysis

The following groups of analyses were conducted as outlined below:

<u>Analytical</u>	
<u>Group</u>	<u>Analyses</u>
1	CVOCs
2	pH, Eh, and temp.
3	CVOCs
4	Metals
5	Anions
6	Alkalinity
7	Dissolved Oxygen (DO)
8	CVOCs
9	Metals
10	Anions
11	Indicator Parameters

Analyses of analytical group 1 and field measurements of analytical group 2 field were conducted to determine when steady state treatment conditions were achieved (designated pre-steady state analyses in Table 4). Once steady state treatment conditions were achieved, a final sampling event for that pump rate was conducted, and analyses of analytical groups 1 through 7 were conducted (designated pre-steady state analyses and intermediate flow rate steady state analyses in Table 4). Analytical groups 2 and 7 were field measurements. All these analyses were conducted by Environmental Restoration Technology Section (ERT) and Analytical Development Section (ADS) as indicated in Table 4.

The data produced was analyzed as outlined below in order to select a new flow rate:

- The PCE, TCE, cDCE, VC, CT, TCM, DCM, and 111-TCA data (as available) from the discharge line were evaluated versus the respective PDWS-MCL (see Table 1).
- The TCE, cDCE, VC, CT, and TCM data from all the SS steel sampling tubes (see Figures 5 and 6) was evaluated using the first order kinetic model to determine the field first order rate constant (k) for each organic contaminant as adequate data existed. The field first order rate constants (k) were utilized to determine the maximum estimated flow rate that would achieve adequate degradation (i.e. below Primary Drinking Water Standard Maximum Contaminant Levels (PDWS-MCLs); see Table 1). The next flow rate utilized was determined based upon this information.

- The field first order rate constant (k) was determined by performing a linear regression of the data as expressed in the $\ln(C/C_0)$ versus t form. The slope of the line produced was the negative of k . The r^2 (coefficient of determination; correlation coefficient) of the linear regression indicated how well the data conformed to the first order kinetic model.

$$\ln(C/C_0) = -kt$$
$$(y = mx + b)$$

where: k = first order rate constant (1/hr)

t = time since reaction began

C = concentration at time t

C_0 = initial concentration

y : $\ln(C/C_0)$

m : $-k$

x : t

b : intercept

The constant pump rate was increased to the new flow rate determined. Subsequent pump rates were increased as long as the higher flow rates were shown to be acceptable versus reduction to the PDWS-MCLs at the discharge sample port.

Once the maximum treatable (i.e. reduction to the PDWS-MCLs at the discharge sample port) flow rate had been determined, a final sampling event for the Phase I testing was conducted and the following analyses were conducted:

- Pre-steady state analyses per Table 4,
- Intermediate flow rate steady state analyses per Table 4, and
- Maximum flow rate steady state per Table 4

The maximum flow rate steady state analyses (analytical groups 8 through 11) were conducted by an EPA certified laboratory (General Engineering Laboratories, Inc.). The group 8 maximum flow rate steady state analyses were conducted on samples from the SS sampling tubes (TGSC-1A through TGSC-1I), the TGSC-1 discharge sample port (TGSC-1S), the end of the discharge line at the NPDES X-08 outfall (TGSC-X8), and monitoring well TCM-2 (assumed to represent the average influent to the GeoSiphon Cell). The group 9, 10, and 11 maximum flow rate steady state analyses were conducted on samples from the TGSC-1 discharge sample port (TGSC-1S), the end of the discharge line at the NPDES X-08 outfall (TGSC-X8), and monitoring well TCM-2 (assumed to represent the average influent to the GeoSiphon Cell).

Table 5 presents the analytical methods utilized by each laboratory and the sample bottles utilized.

Table 4
Analytical Groups

Analytical Group	Laboratory	Analytes
Pre-Steady State Analyses		
1	ERT	Tetrachloroethylene, trichloroethylene, cis 1,2-dichloroethylene, trans 1,2-dichloroethylene, 1,1-dichloroethylene, carbon tetrachloride, chloroform, and 111-trichloroethane
2	ERT	pH, Eh, and temperature
Intermediate Flow Rate Steady State Analyses		
3	ADS	Tetrachloroethylene, trichloroethylene, cis 1,2-dichloroethylene, vinyl chloride, carbon tetrachloride, chloroform, methylene chloride, methyl chloride, and 111-trichloroethane
4	ADS	Silver, aluminum, boron, barium calcium, cadmium, cobalt, chromium, copper, iron, lanthanum, lithium, magnesium, manganese, molybdenum, sodium, nickel, phosphorus, lead, silica, tin, strontium, titanium, vanadium, zinc, and zirconium
5	ADS	Chloride, fluoride, formate, nitrate, nitrite, oxalate, phosphate, and sulfate
6	ADS	Alkalinity
7	ERT	DO
Maximum Flow Rate Steady State Analyses		
8	GEL	Tetrachloroethylene, trichloroethylene, cis 1,2-dichloroethylene, trans 1,2-dichloroethylene, vinyl chloride, carbon tetrachloride, chloroform, methylene chloride, methyl chloride, 111-trichloroethane, chlorobenzene, benzene
9	GEL	Aluminum, calcium, iron, silica, and zinc
10	GEL	Chloride, nitrate/nitrite, and sulfate
11	GEL	gross alpha, Alkalinity, BOD, TOC, TSS,

Table 5
Analytical Methods and Sample Bottles

Analytes	Laboratory	Analytical Method	Sample Volume	Sample Bottle
Tetrachloroethylene, trichloroethylene, cis 1,2-dichloroethylene, trans 1,2-dichloroethylene, 1,1-dichloroethylene, carbon tetrachloride, chloroform, and 111-trichloroethane	ERT	GC-ECD/FID	7.5 ml	20 ml headspace vials ¹
pH Eh DO temperature	ERT	Orion Oakton YSI Orion	20 ml	HDPE
Tetrachloroethylene, trichloroethylene, cis 1,2-dichloroethylene, vinyl chloride, carbon tetrachloride, chloroform, methylene chloride, methyl chloride, and 111-trichloroethane	ADS	GC-MSD	40 ml	40 ml VOA bottle ²
Silver, aluminum, boron, barium calcium, cadmium, cobalt, chromium, copper, iron, lanthanum, lithium, magnesium, manganese, molybdenum, sodium, nickel, phosphorus, lead, silica, tin, strontium, titanium, vanadium, zinc, and zirconium	ADS	ICP-ES	20 ml	20 ml HDPE bottle ³
Chloride, fluoride, formate, nitrate, nitrite, oxalate, phosphate, and sulfate	ADS	IC Anion	40 ml	40 ml VOA bottle ²
Alkalinity	ADS	Alkalinity	40 ml	40 ml VOA bottle ²

Table 5
Analytical Methods and Sample Bottles
 (continued)

Tetrachloroethylene, trichloroethylene, cis 1,2-dichloroethylene, trans 1,2-dichloroethylene, vinyl chloride, carbon tetrachloride, chloroform, methylene chloride, methyl chloride, 111-trichloroethane, chlorobenzene, benzene	GEL	8260 ⁴	40 ml per bottle	2 - 40 ml VOA bottles ⁵
Aluminum, calcium, iron, silica, and zinc	GEL	6010 ⁴	250 ml	250 ml HDPE bottle
Chloride and sulfate	GEL	300 ⁴	500 ml	500 ml HDPE bottle
nitrate/nitrite	GEL	353.1 ⁴	125 ml	125 ml HDPE bottle
gross alpha	GEL	CFPC	1 L	1 L HPDE Bottle
Alkalinity	GEL	310.1 ⁴	1 L	1 L HPDE Bottle
BOD	GEL	405.1 ⁴	1 L	1 L HPDE Bottle
TOC	GEL	415.2 ⁴	250 ml	250 ml AG
TSS	GEL	160.2 ⁴	1 L	1 L HPDE Bottle

Notes to Table 5:

¹ After sample collection, the samples were refrigerated until analyzed.

² A total of 40 ml of sample in one 40 ml VOA bottle was required for the analysis of all three analytical groups. Groundwater was added to the VOA sample bottles until they were completely full and they could be capped without air in the bottle. After sample collection, the samples were refrigerated until analyzed.

³ The sample was preserved with 1 ml of 36.5 - 38% Regent, ACS, HCl.

⁴ SW 846 Method # ; all GEL samples were preserved as specified in the GEL contract.

⁵ Groundwater was added to the VOA sample bottles until they were completely full and they could be capped without air in the bottle.

ERT - Savannah River Technology Center (SRTC) Environmental Restoration Technology Section (ERT)

ADS - Savannah River Technology Center (SRTC) Analytical Development Section (ADS)

GEL - General Engineering Laboratories, Inc.

GC-ECD/FID - gas chromatograph with a electron capture detector and a flame ionization detector

Orion - Orion Model 250A portable pH meter and probe

Oakton - Oakton WD-35615-60 Series portable pH/mV/temperature meter with a double junction ORP electrode

YSI - YSI Model 58 DO meter with Series 5700 oxygen probe

GC-MSD - gas chromatograph with a mass spectrometer detector

ICP-ES - Inductively Coupled Plasma-Emission

IC Anion - Ion chromatography for Anions

5.4 PHASE I TREATABILITY TEST DATA ANALYSIS METHOD

For each flow rate the following data analyses were performed:

- The PCE, TCE, cDCE, VC, CT, TCM, DCM, and 111-TCA data (as available) from the discharge (sample locations TGSC-1I, TGSC-1S, and TGSC-X8) were evaluated versus the respective PDWS-MCL (see Table 1).
- The TCE data from all the SS steel sampling tubes (see Figure 9) was evaluated using the first order kinetic model to determine the field first order rate constant (k). The field first order rate constants (k) were used to determine the next flow rate which would be utilized.

The field first order rate constant (k) was determined by performing a linear regression of the data expressed as $\ln(C/C_0)$ versus t. The slope of the line produced is the negative of k.

$$\ln(C/C_0) = -kt \quad \text{where: } k = \text{first order rate constant (1/hr)}$$

$$(y = mx + b)$$

t = time since reaction began

C = concentration at time t

C₀ = initial concentration

y : $\ln(C/C_0)$

m : -k

x : t

b : intercept

The r^2 (coefficient of determination; correlation coefficient) of the linear regression indicates how well the data conforms to the first order kinetic model.

5.5 PHASE I TREATABILITY TEST RESULTS

During Phase I testing, flow through the TNX GeoSiphon Cell (TGSC-1) was induced by pumping, and the treated water was discharged to the TNX National Pollutant Discharge Elimination System (NPDES) X-08 outfall rather than by siphon directly to the Savannah River. Steady state conditions were created so that field first order rate constants (k) for the CVOCs and the associated acceptable treatment flow rates (i.e. flow rates that allow reduction to below PDWS-MCLs) could be determined. In order to determine k, groundwater contaminant degradation through the granular cast iron was monitored along one horizontal, radial flow path using a series of stainless steel (SS) sampling tube locations (TGSC-1A through TGSC-1I, see Figure 9). In order to determine reduction to below the MCLs, discharge concentrations were determined from a sampling port on the discharge line (TGSC-1S) and from the end of the discharge line at the NPDES X-08 outfall (TGSC-X8; see Figure 10). Additionally average influent concentrations were determined from well TCM-2 (see Figure 6). The flow was increased as treatment was adequately demonstrated and higher flow rates were shown to be acceptable versus reduction to the PDWS-MCLs.

The following Phase I deployment / demonstration flow rates through TGSC-1 were utilized:

- 1 gpm from August 5 to September 30, 1997
- 4 gpm from September 30 to November 11, 1997
- 8 gpm beginning on November 11 to December 16, 1997

The bulk of the data produced during the Phase I testing was produced as process control data originating from the following laboratories at SRS:

- Savannah River Technology Center (SRTC) Environmental Restoration Technology Section (ERT)
- Savannah River Technology Center (SRTC) Analytical Development Section (ADS)

Certain data produced during Phase I testing (~8gpm flow rate) as outlined in Section 5.3.2 was produced as process control data originating from the following EPA certified laboratory:

- General Engineering Laboratories, Inc.

Appendix B provides the following data summary tables associated with the Phase I testing:

- Appendix B-1, 1 gpm Testing - CVOC Data Summary
- Appendix B-2, 1 gpm Steady State CVOC Data Summary - ADS Laboratory
- Appendix B-3, 1 gpm Steady State Inorganic Data Summary - ADS Laboratory
- Appendix B-4, 1 gpm Testing - Field Data Summary
- Appendix B-5, 4 gpm Testing - CVOC Data Summary
- Appendix B-6, 4 gpm Steady State CVOC Data Summary - ADS Laboratory
- Appendix B-7, 4 gpm Steady State Inorganic Data Summary - ADS Laboratory
- Appendix B-8, 4 gpm Testing - Field Data Summary
- Appendix B-9, 8 gpm Testing - CVOC Data Summary
- Appendix B-10, 8 gpm Steady State CVOC Data Summary - ADS Laboratory
- Appendix B-11, 8 gpm Steady State CVOC Data Summary - GEL Laboratory
- Appendix B-12, 8 gpm Steady State Inorganic Data Summary - ADS Laboratory
- Appendix B-13, 8 gpm Steady State Inorganic Data Summary - GEL Laboratory
- Appendix B-14, 8 gpm Testing - Field Data Summary
- Appendix B-15, Steady State CVOC Data Summary
- Appendix B-16, Steady State Inorganic Data Summary
- Appendix B-17, Steady State Field Data Summary

Discussion of selected data from the steady state conditions at each flow rate follow. Only selected summary data will be presented in tabular form throughout the text of this report. Appendices B-1 through B-17 should be consulted for specific data needs.

5.5.1 Phase I Treatability Test CVOC Results

5.5.1.1 Phase I Treatability Test CVOC Data Summary

Table 6 provides a summary of the steady state data produced for TCE, cDCE, CT, and TCM for each flow rate from each laboratory as available. Table 7 provides the average CVOC data produced by General Engineering Laboratories at the 8 gpm flow rate. Table 8 provides a summary of the steady state data produced for pH, DO, and Eh at each of the flow rates utilized. The data presented in Tables 6 through 8 provides the bulk of the data discussed within this section and the bulk of the data utilized within the associated figures. Appendices B-1 through B-17 provide all the data produced during Phase I deployment / demonstration.

Table 6
Summary Steady State CVOC Data

Sample Location	Distance into Cell (ft)	Lab	ERT	ADS	ERT Average	ADS	ERT Average	ADS	GEL Average
		Date	9/30/97	9/30/97	11/11/97	11/11/97	12/16/97	12/16/97	12/16/97
		Flow (gpm)	0.97	0.97	4.00	4.00	7.98	7.98	7.98
		CVOC							

TCM-2	0	TCE	NA	NA	243.2	143.7	218.8	135.85	220.0
TGSC-1A	0	TCE	193.8	156.0	197.0	156.1	186.9	133.65	160.5
TGSC-1B	0.14	TCE	44.7	27.0	172.7	158.8	43.2	9.45	54.2
TGSC-1C	0.32	TCE	8.1	5.4	94.1	66.9	53.6	44.6	47.1
TGSC-1D	0.64	TCE	ND	<1	40.4	27.8	56.3	40.3	45.7
TGSC-1E	1.07	TCE	ND	<1	3.9	2.4	29.9	20.3	25.3
TGSC-1F	1.5	TCE	ND	<1	ND	<1	1.1	<1	1.1
TGSC-1G	2.04	TCE	ND	<1	ND	<1	0.3	<1	<1.00
TGSC-1H	2.86	TCE	ND	<1	ND	<1	0.2	<1	<1.00
TGSC-1I	3.47	TCE	ND	<1	1.2	<1	5.2	3.4	4.3
TGSC-1S	-	TCE	0.2	<1	1.0	<1	5.3	3.55	4.4
TGSC-X8	-	TCE	ND	<1	1.0	<1	4.8	3.5	4.8

TCM-2	0	cDCE	NA	NA	30.6	24.1	26.2	21.35	37.1
TGSC-1A	0	cDCE	27.9	22.0	28.7	25.2	32.1	19.55	27.5
TGSC-1B	0.14	cDCE	<10	3.5	24.5	22.7	17.6	2.15	16.7
TGSC-1C	0.32	cDCE	ND	3.3	22.7	17.8	12.3	11.2	16.2
TGSC-1D	0.64	cDCE	ND	2.6	15.0	11.5	27.1	11.2	17.3
TGSC-1E	1.07	cDCE	ND	1.1	ND	2.3	ND	4.1	6.4
TGSC-1F	1.5	cDCE	ND	<1	ND	0.8	ND	1.3	1.6
TGSC-1G	2.04	cDCE	ND	<1	ND	0.4	ND	<1	0.8
TGSC-1H	2.86	cDCE	ND	<1	ND	0.2	ND	<1	<1.00
TGSC-1I	3.47	cDCE	ND	<1	ND	3.6	11.8	5.1	7.6
TGSC-1S	-	cDCE	ND	<1	ND	2.7	ND	4.85	6.5
TGSC-X8	-	cDCE	ND	<1	ND	2.9	ND	4.55	6.6

Table 6
Summary Steady State CVOC Data
 (continued)

Sample Location	Distance into Cell (ft)	Lab	ERT	ADS	ERT Average	ADS	ERT Average	ADS	GEL Average
		Date	9/30/97	9/30/97	11/11/97	11/11/97	12/16/97	12/16/97	12/16/97
		Flow (gpm)	0.97	0.97	4.00	4.00	7.98	7.98	7.98
		CVOC							

TCM-2	0	CT	NA	NA	35.1	16.5	24.7	18.15	23.0
TGSC-1A	0	CT	29.0	20.0	13.2	7	9.5	7.75	8.8
TGSC-1B	0.14	CT	ND	<1	0.1	<1	ND	<1	<1.00
TGSC-1C	0.32	CT	ND	<1	ND	<1	ND	<1	<1.00
TGSC-1D	0.64	CT	ND	<1	ND	<1	ND	<1	<1.00
TGSC-1E	1.07	CT	ND	<1	ND	<1	ND	<1	<1.00
TGSC-1F	1.5	CT	ND	<1	ND	<1	ND	<1	<1.00
TGSC-1G	2.04	CT	ND	<1	ND	<1	ND	<1	<1.00
TGSC-1H	2.86	CT	ND	<1	ND	<1	ND	<1	<1.00
TGSC-1I	3.47	CT	ND	<1	ND	<1	ND	<1	<1.00
TGSC-1S	-	CT	ND	<1	ND	<1	ND	<1	<1.00
TGSC-X8	-	CT	ND	<1	ND	<1	ND	<1	<1.00

TCM-2	0	TCM	NA	NA	3.4	2.7	3.4	3.35	3.7
TGSC-1A	0	TCM	3.1	2.2	7.5	6.7	6.2	5.95	6.1
TGSC-1B	0.14	TCM	0.4	<1	6.7	6.3	1.5	<1	2.3
TGSC-1C	0.32	TCM	ND	<1	1.9	1.8	1.7	1.5	1.9
TGSC-1D	0.64	TCM	ND	<1	0.8	0.8	2.6	1.9	2.3
TGSC-1E	1.07	TCM	ND	<1	ND	<1	0.9	<1	0.8
TGSC-1F	1.5	TCM	ND	<1	ND	<1	ND	<1	<1.00
TGSC-1G	2.04	TCM	ND	<1	ND	<1	ND	<1	<1.00
TGSC-1H	2.86	TCM	ND	<1	ND	<1	ND	<1	<1.00
TGSC-1I	3.47	TCM	ND	<1	ND	<1	ND	<1	<1.00
TGSC-1S	-	TCM	ND	<1	ND	<1	ND	<1	0.3
TGSC-X8	-	TCM	ND	<1	ND	<1	ND	<1	0.3

Notes:

NA = Not analyzed; ND = Not detected;

ERT = SRTC Environmental Restoration Technology Section; ADS = SRTC Analytical Development Section; GEL = General Engineering Laboratories, Inc.

TCE = trichloroethylene; cDCE = cis-1,2-dichloroethylene; CT = carbon tetrachloride;

TCM = chloroform

All concentrations in ug/L (ppb)

Table 7
8 gpm Steady State Average CVOC Data - GEL Laboratory

Sample Location	Distance into Cell (ft)	Parameter					
		PCE	TCE	cDCE	tDCE	VC	CT
TCM-2	0.00	2.6	220.0	37.1	0.3	<1.00	23.0
TGSC-1A	0.00	0.7	160.5	27.5	0.3	<1.00	8.8
TGSC-1B	0.14	<1.00	54.2	16.7	<1.00	<1.00	<1.00
TGSC-1C	0.32	<1.00	47.1	16.2	<1.00	<1.00	<1.00
TGSC-1D	0.64	<1.00	45.7	17.3	<1.00	<1.00	<1.00
TGSC-1E	1.07	<1.00	25.3	6.4	<1.00	<1.00	<1.00
TGSC-1F	1.50	<1.00	1.1	1.6	<1.00	<1.00	<1.00
TGSC-1G	2.04	<1.00	<1.00	0.8	<1.00	<1.00	<1.00
TGSC-1H	2.86	<1.00	<1.00	<1.00	<1.00	<1.00	<1.00
TGSC-1I	3.47	<1.00	4.3	7.6	<1.00	<1.00	<1.00
TGSC-1S	-	<1.00	4.4	6.5	<1.00	<1.00	<1.00
TGSC-X8	-	<1.00	4.8	6.6	<1.00	<1.00	<1.00

Sample Location	Distance into Cell (ft)	Parameter					
		TCM	DCM	CM	111-TCA	Cbenzene	Benzene
TCM-2	0.00	3.7	<1.00	<1.00	<1.00	<1.00	<1.00
TGSC-1A	0.00	6.1	<1.00	<1.00	<1.00	<1.00	<1.00
TGSC-1B	0.14	2.3	<1.00	<1.00	<1.00	<1.00	<1.00
TGSC-1C	0.32	1.9	<1.00	<1.00	<1.00	<1.00	<1.00
TGSC-1D	0.64	2.3	<1.00	<1.00	<1.00	<1.00	<1.00
TGSC-1E	1.07	0.8	<1.00	<1.00	<1.00	<1.00	<1.00
TGSC-1F	1.50	<1.00	<1.00	<1.00	<1.00	<1.00	<1.00
TGSC-1G	2.04	<1.00	<1.00	<1.00	<1.00	<1.00	<1.00
TGSC-1H	2.86	<1.00	<1.00	<1.00	<1.00	<1.00	<1.00
TGSC-1I	3.47	<1.00	<1.00	<1.00	<1.00	<1.00	<1.00
TGSC-1S	-	0.3	<1.00	<1.00	<1.00	<1.00	<1.00
TGSC-X8	-	0.3	<1.00	<1.00	<1.00	<1.00	<1.00

Notes:

GEL = General Engineering Laboratories, Inc.

PCE = tetrachloroethylene; TCE = trichloroethylene; cDCE = cis-1,2-dichloroethylene; tDCE = trans-1,2-dichloroethylene; VC = vinyl chloride; CT = carbon tetrachloride;

TCM = chloroform; DCM = methylene chloride; CM = methyl chloride;

111-TCA = 1,1,1-trichloroethane; cBenzene = chlorobenzene; Benzene = benzene

All concentrations in ug/L (ppb)

Table 8
Steady State Field Data - ERT

Sample Location	Distance into Cell (ft)	Date	9/30/97	11/11/97	12/16/97
		Flow (gpm)	0.97	4.00	7.98
		Parameter			
TCM-2	0	pH	NA	4.46	5.45
TGSC-1A	0	pH	5.3	5.15	6.08
TGSC-1B	0.14	pH	7.01	6.52	7.18
TGSC-1C	0.32	pH	6.85	6.83	7.21
TGSC-1D	0.64	pH	6.92	6.93	7.49
TGSC-1E	1.07	pH	8.08	6.37	7.21
TGSC-1F	1.5	pH	8.97	6.83	7.32
TGSC-1G	2.04	pH	8.98	7.29	7.24
TGSC-1H	2.86	pH	8.64	6.8	7.16
TGSC-1I	3.47	pH	9.42	9	9.03
TGSC-1S	-	pH	9.52	8.81	8.65
TGSC-X8	-	pH	9.59	8.48	8.83

TCM-2	0	DO, mg/l	NA	3.1	3
TGSC-1A	0	DO, mg/l	4.1	4.2	2.5
TGSC-1B	0.14	DO, mg/l	1.9	2.4	2
TGSC-1C	0.32	DO, mg/l	2	1.9	2.4
TGSC-1D	0.64	DO, mg/l	2	1.9	2.4
TGSC-1E	1.07	DO, mg/l	1.7	2.6	2.6
TGSC-1F	1.5	DO, mg/l	1.9	2.7	2.4
TGSC-1G	2.04	DO, mg/l	1.9	2.3	2.4
TGSC-1H	2.86	DO, mg/l	1.9	2.1	2.7
TGSC-1I	3.47	DO, mg/l	1.9	2.2	2.3
TGSC-1S	-	DO, mg/l	1.2	1.7	1
TGSC-X8	-	DO, mg/l	1.4	1.6	1.1

TCM-2	0	Eh, mV	NA	453.1	456.6
TGSC-1A	0	Eh, mV	NA	316.3	430.8
TGSC-1B	0.14	Eh, mV	NA	71.4	29.2
TGSC-1C	0.32	Eh, mV	NA	-1.1	31.2
TGSC-1D	0.64	Eh, mV	NA	7.1	18.2
TGSC-1E	1.07	Eh, mV	NA	-12.1	56.8
TGSC-1F	1.5	Eh, mV	NA	-85.2	62.6
TGSC-1G	2.04	Eh, mV	NA	-121.3	50.3
TGSC-1H	2.86	Eh, mV	NA	-166.7	46.8
TGSC-1I	3.47	Eh, mV	NA	-129.3	-8.6
TGSC-1S	-	Eh, mV	NA	-140.2	-11.7
TGSC-X8	-	Eh, mV	NA	-74.3	34

Notes: NA = Not analyzed; ERT = SRTC Environmental Restoration Technology Section

5.5.1.2 Phase I Treatability Test CVOC Data Evaluation

Figures 11 and 12 present the steady state degradation profiles through the TGSC-1 granular cast iron (sampling locations TGSC-1A through TGSC-1I) and the discharge from the cell (sampling location TGSC-1S and TGSC-X8) at approximately 1 gpm for TCE and cDCE, and CT and TCM, respectively. As shown along this flow path at the 1 gpm flow rate the TCE, cDCE, CT, and TCM were degraded from concentrations (EST data from sampling port TGSC-1A) of 193.8 ppb, 27.9 ppb, 29.0 ppb, and 3.1 ppb, respectively, to below the detection limits within six inches into the granular cast iron. Approximately 3-½ feet of iron is available for treatment. All discharge concentrations (sampling location TGSC-1S and TGSC-X8) were below detection (see Table 6). Figure 13 presents the pH profile at approximately 1 gpm. As shown the pH increased from approximately 5.3 to greater than 9. The Eh was not measured during the 1 gpm test.

Figures 14 and 15 present the well TCM-2 concentrations, the steady state degradation profiles through the TGSC-1 granular cast iron (sampling locations TGSC-1A through TGSC-1I), and the discharge from the cell (sampling location TGSC-1S and TGSC-X8) at approximately 4 gpm for TCE and cDCE, and CT and TCM, respectively. As shown along this flow path at the 4 gpm flow rate the TCE, cDCE, CT, and TCM were degraded from concentrations (average EST data from sampling port TGSC-1A) of 197 ppb, 28.7 ppb, 13.2 ppb, and 7.5 ppb, respectively, to below detection within approximately 13 inches into the granular cast iron. Approximately 3-½ feet of iron is available for treatment. A four fold increase in the flow rate did not produce a corresponding four fold increase in penetration into the iron; rather a penetration increase of slightly greater than two fold was seen. The TCE, cDCE, CT, and TCM discharge concentrations (sampling location TGSC-1S and TGSC-X8) were below 1.0 ppb, 2.9 ppb, below detection, and below detection, respectively (see Table 6). Figure 16 presents the pH and Eh (oxidation/reduction potential) profile at approximately 4 gpm. As shown the pH increased from approximately 5.2 to generally around 7 within the iron and then to between 8 and 9 in the discharge. The oxidation/reduction potential went from generally oxidizing conditions to generally reducing conditions. Figure 17 presents the DO (dissolved oxygen) profile at approximately 4 gpm. As shown the DO decreases quickly from the influent concentrations once the groundwater enters the iron bed, and it appears that the DO also slightly decreases upon exiting the iron bed.

Figures 18 and 19 present the well TCM-2 concentrations, the steady state degradation profiles through the TGSC-1 granular cast iron (sampling locations TGSC-1A through TGSC-1I), and the discharge from the cell (sampling location TGSC-1S and TGSC-X8) at approximately 8 gpm for TCE and cDCE, and CT and TCM, respectively. As shown along this flow path at the 8 gpm flow rate the TCE, cDCE, CT, and TCM were degraded from concentrations (average EST data from sampling port TGSC-1A) of 186.9 ppb, 32.1 ppb, 9.5 ppb, and 6.2 ppb, respectively, to below detection within approximately 18 inches into the granular cast iron. Approximately 3-½ feet of iron is available for treatment. A doubling of the flow rate did not produce a

corresponding doubling in penetration into the iron; rather a penetration increase of less forty percent was seen. The TCE, cDCE, CT, and TCM discharge concentrations (sampling location TGSC-1S and TGSC-X8) were between 3.5 and 5.6, below 7.7 ppb, below detection, and below detection, respectively (see Table 6 and the latter discussion in this section concerning what the various sample ports actually represent). Figure 20 presents the pH and Eh (oxidation/reduction potential) profile at approximately 8 gpm. As shown the pH increased from approximately 6.1 to generally around 7 within the iron and then to between 8 and 9 in the discharge. The oxidation/reduction potential went from generally oxidizing conditions to generally reducing conditions. Figure 21 presents the DO (dissolved oxygen) profile at approximately 8 gpm. As shown the DO remained relatively the same throughout the iron bed, but it appears that the DO slightly decreased upon exiting the iron bed.

The degradation profiles for TCE, cDCE, CT, and TCM presented in Figures 18 and 19 show a hump in the profiles that is not evident in the 1 gpm and 4 gpm profiles. The cause of this deviation has not been determined; however the following are potential explanations:

- Colder weather during the 8 gpm steady state sampling event could have reduced the effectiveness of the seal between the Teflon coated metal plunger and the glass syringe; thereby negatively impacting the sample quality. The Environmental Restoration Technology (ERT) samples were taken with the glass syringes; however the General Engineering Laboratories, Inc. (GEL) samples were taken with disposable plastic syringes, which are not affected by cold weather. Both the ERT and GEL sample results show similar pattern; therefore it does not appear that sampling with the glass syringes significantly impacted the results.
- At the higher flow rates the flow paths through the GeoSiphon Cell may not be completely horizontal, but may have a vertical component to the flow. Since the contamination coming into the GeoSiphon Cell is highly stratified (see Figure 7), a vertical component to flow through the cell could cause the sample ports, which all have 3 inch screen zones all at the same elevation, to intersect different degradation profiles which began at different initial concentrations.

Figures 22, 23, and 24 present degradation profiles for TCE and cDCE, for CT and TCM, and for pH and Eh, respectively, at an earlier non-steady state 8 gpm sampling event for comparison to the steady state sampling event shown in Figures 18, 19, and 20. The non-steady state degradation profiles show a similar but muted hump in the degradation profile similar to that of the steady state profile, and the pH and Eh profiles are almost identical. The non-steady state sampling event was conducted at a flow rate of 7.68 gpm versus the 7.98 gpm of the steady state sampling event. This lesser flow rate could account for the muted hump, and lends credence to the hump formation being caused by increased vertical components of flow with increased flow rates as discussed above.

Figures 14, 15, 18, and 19 and Table 6 generally show that the concentrations of TCE, cDCE, and CT from well TCM-2 are generally greater than the concentrations from sampling port TGSC-1A. Figures 18 and 19 and Table 6 show that the concentrations of TCE and cDCE decline to less than detection as flow proceeds from TGSC-1A through TGSC-1H, and then the concentration increase to above detection in TGSC-1I, TGSC-1S, and TGSC-X8. As stated in section 5.3.1 and Table 3:

- Monitoring well TCM-2 samples should generally represent the average influent to the GeoSiphon Cell, since TCM-2 is screened over the entire GeoSiphon Cell treatment zone depth and is only 25 feet upgradient of the cell
- Sample port TGSC-1A represents the influent to the GeoSiphon Cell along one horizontal, radial, flow path through the treatment zone, since, it has a 3 inch screen zone at an elevation of approximately 87 ft-msl.
- Sample ports TGSC-1B through TGSC-1H represent degradation through the GeoSiphon Cell along one horizontal, radial, flow path through the treatment zone, since, they all have a 3 inch screen zone at an elevation of approximately 87 ft-msl.
- Sample ports TGSC-1I, TGSC-1S, and TGSC-X8 represent the average effluent from the GeoSiphon Cell, since samples from these ports are collected after entrance of the treated water into the 12 inch central screen zone.

The distribution of contaminants within the formation (see Figure 7) is significantly stratified. Since concentrations from TCM-2 are generally greater than that of TGSC-1A and since TCM-2 represents the average influent and TGSC-1A represents the influent along one flow path, there are flow paths through the GeoSiphon Cell which have influent concentrations greater than those of TCM-2. Therefore the flow path of sample ports TGSC-1A through TGSC-1H represents a less than average TCE concentration flow path. This stratification and single flow path concentrations versus average cell concentrations, results in the increase from detection that is seen as proceeding from the TGSC-1A to TGSC-1H sample ports to TGSC-1I, TGSC-1S and TGSC-X8. All of this means that while the geonet with geotextile may produce a more even distribution of the contaminants over the granular cast iron cylinder surface area than exists within the formation itself, it does not completely average out the formation distribution over the iron surface area (i.e. the contaminant influent profile to the GeoSiphon Cell is still significantly stratified. This stratification also has an impact on the pH, Eh, and other inorganic data presented in section 5.5.2.2.

Throughout the testing none of the following compounds were detected by any of the laboratories in any of the samples (the detection limit was 1 ug/l for all these compounds for each laboratory which conducted these analysis):

- vinyl chloride (chloroethylene, VC)
- methyl chloride (chloromethane, CM)

- 1-1-1, trichloroethane (111 TCA)
- chlorobenzene
- benzene

Figure 25 presents a comparison of the pH profiles for each of the steady state flow rates along with the laboratory column test profile. As with the laboratory column testing, the pH increased with travel through the granular cast iron in TGSC-1 (see Figure 25). The 1 gpm steady state GeoSiphon pH profile is essentially identical to the laboratory column profile, which showed a pH increase with travel through the iron to a pH of approximately 9. While the profiles associated with the higher GeoSiphon flow rates (ie. 4 and 8 gpm) showed an increase in pH over influent values, the pH only increased to a value slightly greater than 7 with travel through the iron. The higher GeoSiphon flow rate pH profiles appear to be depressed with travel through the iron, relative to the column test and the 1 gpm GeoSiphon flow rate. See section 5.5.2.2 for further discussions concerning pH.

Figure 26 presents a comparison of the Eh profiles for each of the steady state flow rates along with the laboratory column test profile. As with the laboratory column testing, the Eh (oxidation/reduction potential) decreased (that is, reducing conditions were produced) with travel through the granular cast iron in TGSC-1 (see Figure 26). A 1 gpm steady state GeoSiphon Eh profile was not produced during this testing, but it is assumed that such a profile would be similar to the laboratory column profile, which showed an Eh decrease with travel through the iron to a pH to approximately -300 mV. While both the 4 gpm and 8 gpm steady state GeoSiphon Eh profiles showed a decrease in Eh over influent values, the Eh only decreased to approximately -170 mV and 50 mV, respectively, with travel through the iron. As can be seen in Figure 26, increasing flow rates produced less reduction in Eh with travel through the iron. See section 5.5.2.2 for further discussions concerning Eh.

Figures 27, 28, 29, and 30, respectively, present a comparison of the TCE, cDCE, CT, and TCM profiles for each of the steady state flow rates along with the laboratory column test profile. The TCE and CT degradation profiles produced within TGSC-1 (Figures 27 and 29) were generally consistent with those produced during the 100% iron laboratory column test (with the exception of the hump associated with the 8 gpm profiles as addressed above). However the cDCE and TCM degradation profiles produced within TGSC-1 (Figures 28 and 30) were not consistent with those produced during the 100% iron laboratory column test. During the 100% iron laboratory column test approximately 20% of the original TCE mass was converted to cDCE as an intermediate degradation product (see Figure 28 for the increase and subsequent degradation of cDCE associated with the laboratory column test). Also during the 100% iron laboratory column test approximately 10% of the original CT mass was converted to TCM as an intermediate degradation product (see Figure 30 for the increase and subsequent degradation of TCM associated with the laboratory column test). TGSC-1 appears to be producing significantly less, if any, cDCE and TCM as TCE and CT intermediate degradation products, respectively, than

produced during in the laboratory study. It is believed that the humps in the cDCE and TCM profiles at the 8 gpm flow rates, are due to contaminant stratification and a vertical component to flow at the higher flow rates, which cause the sample ports to intersect different flow paths, rather than production of cDCE and TCM as an intermediate degradation products. The cDCE and TCM 8 gpm profiles are similar to the TCE 8 gpm profiles (see Figure 27), which further confirms that the cDCE and TCM humps are not due to production of intermediate degradation products.

As stated above no vinyl chloride (VC) was detected from the TGSC-1 testing; whereas sporadic detectable levels of VC were seen during the laboratory column test. Based upon the observation of the lack of cDCE, VC, and TCM intermediate degradation product production, it appears that degradation within TGSC-1 is predominately following the postulated multiple dechlorination pathway (chloroacetylene/acetylene) outlined Section 3.2. Appendix B-10 presents the results of the CVOC analysis conducted on the 8 gpm steady state samples by the ADS laboratory. These samples were analyzed for chloroacetylene and acetylene in addition to the other CVOCs. No chloroacetylene nor acetylene was detected above their respective detection limits of 30 ug/l and 13 ug/l. However this lack of detection does not necessarily mean that chloroacetylene and acetylene are not produced during the process; it could just relate to the instability of these compounds, which results in their immediate degrade upon production.

Calculations, based upon the laboratory data produced first order reaction rates and assumed intermediate production, indicated that the degradation of vinyl chloride (VC) would be the limiting compound in treating to below the PDWS-MCLs. This does not, however, appear to be the case within the TNX GeoSiphon Cell (TGSC-1); rather the degradation of TCE, itself, appears to be the limiting compound in treating to below the PDWS-MCLs.

Since degradation of TCE within TGSC-1 is the limiting compound to treatment below the PDWS-MCLs, the GeoSiphon Cell TCE discharge data from sample locations TGSC-II, TGSC-1S, and TGSC-X8 at the various steady state flow rates was evaluated versus the TCE MCL of 5 ppb. Figure 31 presents the flow rate versus TCE discharge concentration along with the associated best fit equations for the data produced by the Environmental Restoration Technology Section (ERT) and by the Analytical Development Section (ADS) / General Engineering Laboratories, Inc. (GEL). The ERT and ADS / GEL best fit equations were generated separately since the ERT data was produced using a GC headspace method and the ADS / GEL data was produced using a GC/MS purge and trap solvent extraction method. The ERT best fit indicates that a maximum flow rate of 7.8 gpm will maintain the average discharge TCE concentration below 5 ug/l, while the ADS / GEL best fit indicates that a maximum flow rate of 8.3 gpm will maintain the average discharge TCE concentration below 5 ug/l.

5.5.1.3 Phase I Treatability Test TCE First Order Rate Constant Determination

Since degradation of TCE itself within TGSC-1 is the limiting compound to treatment below the PDWS-MCLs, linear regression analyses were performed on only the TCE data in order to determine its field first order rate constant (k). The TCE data was expressed as $\ln(C/C_0)$ versus t for the determination of field first order rate constants (k). The following appendices present the Excel spreadsheets of the linear regression analyses for the TCE data:

- Appendix C-1, Laboratory Column Test First Order Rate Constant
- Appendix C-2, 1 gpm First Order Rate Constant (9/30/97 Steady State Sampling Event at 0.97 gpm)
- Appendix C-3, 4 gpm First Order Rate Constant (11/11/97 Steady State Sampling Event at 4.00 gpm)
- Appendix C-4, 8 gpm First Order Rate Constant (12/16/97 Steady State Sampling Event at 7.98 gpm)
- Appendix C-5, 7.68 gpm First Order Rate Constant (12/2/97 Sampling Event at 7.68 gpm)

Typically flow velocities through permeable treatment beds are constant, therefore distance through the bed is directly proportional to the time to reach each point within the bed. However the GeoSiphon Cell produces radially, inward, horizontal flow through the treatment media, which produces increasing velocities toward the center of the cell. Figure 32 presents the velocity profile through the TNX GeoSiphon Cell at each of the steady state flow rates. These flow rate curves were utilized to convert the distance of each sampling port within the cell to time of travel for use in the linear regression analysis for the determination of the field first order rate constant (k). Figures 33, 34, 35, and 36 graphically depict the results of the performance of the linear regressions on the TCE data for the determination of k from the laboratory column test and the 1 gpm, 4 gpm, and 8 gpm Phase I steady state tests, respectively. Additionally Figure 37 provides the linear regression on the TCE data for the determination of k from the earlier non-steady state 8 gpm sampling event, which was previously used for comparison to the 8 gpm steady state sampling event.

Table 9 provides a summary of the first order rate constants (k) produced during these analyses. Fairly good fits of the data were obtained with the linear regression analyses as seen from the associated the r squares produced (see Table 9). The average first order rate constant produced from the laboratory column test was 1.873 /hr. The average first order rate constants produced from the 1 gpm, 4 gpm, and 8 gpm steady state TCE data, respectively, were 0.347 /hr, 0.578 /hr, and 0.917 /hr. The average first order rate constant produced from the 7.68 gpm non-steady state TCE data was 0.849 /hr. The TGSC-1 data indicates that up to some point the k increases with flow rate or velocity, assuming other variables remain constant.

Table 9
First Order Rate Constant (k) Summary

Condition	Data Set	TCE k (1/hr)	r squared
Laboratory Column Test (0.0054 fpm average velocity)	EnviroMetal Technologies, Inc.	1.865	0.949
TGSC-1 (0.97 gpm, steady state; 0.0010 fpm average velocity)	ADS	0.356	0.993
	EST	0.337	1.000
	Average	0.347	-
TGSC-1 (4.00 gpm, steady state; 0.0039 fpm average velocity)	ADS	0.610	0.945
	EST	0.540	0.913
	EST - Duplicate	0.584	0.962
	Average	0.578	-
TGSC-1 (7.98 gpm, steady state; 0.0079 fpm average velocity)	ADS	0.695	0.529
	EST	1.012	0.890
	EST - Duplicate	0.997	0.891
	GEL	0.860	0.758
	GEL - Duplicate	1.024	8.72
	Average	0.917	-
TGSC-1 (7.68 gpm, non-steady state; 0.0076 fpm average velocity)	EST	0.820	0.672
	EST - Duplicate	0.877	0.783
	Average	0.849	-

Table 10 provides a comparison of the initial TCE concentration, the iron porosity, the average velocity through the iron, and the average first order rate constant (k) associated with the laboratory column test and each of the Phase I steady state flow rates. The laboratory column test had an initial TCE concentration similar to that seen in the GeoSiphon Cell testing, its iron porosity was less than that of TGSC-1 (meaning that the surface area available for reaction per unit volume was greater than that of TGSC-1, since the exact same particle sized iron was utilized in both), and the average velocity of the column test was near the mid-point of that utilized within the GeoSiphon Cell. Since the column test average velocity was near the mid-point of that utilized within the GeoSiphon Cell, and since the column test had more surface area per unit volume, the column test first order reaction rate (k) results are likely to be comparable to the TGSC-1 results at a flow rate higher than that utilized.

Table 10
Initial TCE Concentration / Iron Porosity / Average Velocity Comparison

System	Initial TCE Concentration (ug/L)	Iron Porosity (%)	Average Velocity (ft/min)	Average k (1/hr)
Laboratory Column Test	161	51	0.0054	1.865
TGSC-1 (0.97 gpm, steady state)	193.8	68	0.0010	0.347
TGSC-1 (4.00 gpm, steady state)	197.0	68	0.0039	0.578
TGSC-1 (7.98 gpm, steady state)	186.9	68	0.0079	0.917
TGSC-1 (7.68 gpm, non-steady state)	193.8	68	0.0076	0.849

Figure 38 presents the flow rate versus the first order rate constants (k) produced from the steady state TGSC-1 data. A linear regression of the data was performed. As can be seen there appears to be a very good direct correlation ($r^2 = 0.999$) between increasing flow rate (or velocity) and increases in the k. The 7.68 gpm non-steady state data was added to the steady state data and a separate linear regression was performed (see Figure 39). This non-steady state data point fits in very well with the correlation produced from the steady state data, indicating a very good direct correlation ($r^2 = 0.995$) between increasing flow rate (or velocity) and increases in the k.

The maximum field first order rate constant of 0.917 /hr is approximately a half of that produced during the laboratory column test. However, this does not negatively affect the maximum flow rate for which TGSC-1 will provide adequate treatment, since significantly less TCE intermediate degradation products are being produced within TGSC-1 than indicated by the laboratory column test.

The degradation of TCE by granular cast iron does not appear to be a real first order reaction dependent upon TCE alone, therefore first order rate constants produced from TCE degradation data are really pseudo first order rate constants dependent upon other variables such as:

- The reactive iron surface area available (it appears that the more surface area available per unit volume, the greater the calculated first order rate constant)
- The initial concentration of TCE (it appears that the greater the initial TCE concentration up to a point, the greater the calculated first order rate constant)

- The flow through velocity (it appears that the greater the flow through velocity up to a point, the greater the calculated first order rate constant)
- Any other parameter that impacts the transport of the TCE to the surface reactive sites on the iron

First order rate constants produced from various TCE degradation data have the potential of being directly comparable only when all pertinent conditions except one remain constant.

Linear regression analyses to determine field first order rate constants have not been performed for compounds other than TCE, since TCE degradation is the limiting factor, not enough data exists for such an analysis for other compounds, and/or the compound is already below its respective PDWS-MCL.

5.5.1.4 Phase I Treatability Test CVOC Summary

During Phase I testing, flow through the TNX GeoSiphon Cell (TGSC-1) was induced by pumping, and the treated water was discharged to the TNX National Pollutant Discharge Elimination System (NPDES) X-08 outfall rather than by siphon directly to the Savannah River. Steady state conditions were created so that field first order rate constants (k) for the CVOCs and the associated acceptable treatment flow rates (i.e. flow rates that allow reduction to below PDWS-MCLs) could be determined. In order to determine k , groundwater contaminant degradation through the granular cast iron was monitored along one horizontal, radial flow path using a series of stainless steel (SS) sampling tube locations (TGSC-1A through TGSC-1I, see Figure 9). In order to determine reduction to below the MCLs, discharge concentrations were determined from a sampling port on the discharge line (TGSC-1S) and from the end of the discharge line at the NPDES X-08 outfall (TGSC-X8; see Figure 10).

The following Phase I flow rates through TGSC-1 were utilized:

- 1 gpm from August 5 to September 30, 1997
- 4 gpm from September 30 to November 11, 1997
- 8 gpm beginning on November 11 to December 16, 1997

The following are the major conclusions that can be drawn from the Phase I Treatability Test:

- As with the laboratory column testing, the pH increased with travel through the granular cast iron in TGSC-1, however the increase in pH at higher GeoSiphon flow rates was depressed relative to the column test and the 1 gpm GeoSiphon flow rate.
- As with the laboratory column testing, the Eh (oxidation/reduction potential) decreased (that is, reducing conditions were produced) with travel through the granular cast iron in

TGSC-1, however the magnitude of the Eh reduction decreased with increasing flow rates.

- TGSC-1 appears to be producing significantly less, if any, cDCE and TCM as TCE and CT intermediate degradation products, respectively, than produced during in the laboratory study. Additionally no vinyl chloride (VC) was detected from the TGSC-1 testing; whereas sporadic detectable levels of VC were seen during the laboratory column test. Based upon the observation of the lack of cDCE, VC, and TCM intermediate degradation product production, it appears that degradation within TGSC-1 is predominately following the postulated multiple dechlorination pathway (chloroacetylene/acetylene).
- Based upon the laboratory data, the degradation of vinyl chloride (VC) was assumed to be the limiting compound in treating the groundwater to below the PDWS-MCLs. This does not, however, appear to be the case within the TNX GeoSiphon Cell; rather the degradation of TCE, itself, appears to be the limiting compound in treating to below the PDWS-MCLs.
- The data indicates that a maximum flow rate of between 7.8 gpm and 8.3 gpm can be treated while maintaining the average discharge TCE concentration below 5 ug/l.
- The average TCE first order rate constants (k) and the associated half-lives ($t_{1/2}$) produced from steady state TCE data is shown below. This data indicates that up to some point the k increases with flow rate or velocity, assuming that other variables remain constant. The linear regression of flow rate versus k produced an r squared of 0.999, which indicates a very good correlation.

Flow Rate (gpm)	k (1/hr)	$t_{1/2}$ (hrs)
0.97	0.347	2.0
4.00	0.578	1.2
7.98	0.917	0.76

- The maximum field first order rate constant of 0.917 /hr is approximately a half of that produced during the laboratory column test. However, this does not negatively affect the maximum flow rate for which TGSC-1 will provide adequate treatment, since significantly less TCE intermediate degradation products were produced within TGSC-1 than indicated by the laboratory column test.
- While the geonet with geotextile may produce a more even distribution of the contaminants over the granular cast iron cylinder surface area than exists within the formation itself, it does not completely average out the formation distribution over the iron surface area (i.e. the contaminant influent profile to the GeoSiphon Cell treatment media is still significantly stratified).

5.5.2 Phase I Treatability Test Inorganic Results

5.5.2.1 Phase I Treatability Test Inorganic Data Summary

Table 11 provides a summary of the steady state influent and effluent inorganic data for each flow rate from each laboratory as available. Additional inorganic data is provided in Appendices B-3, B-7, and B-12 from the sampling ports located within the iron treatment zone. Table 12 provides the average GEL indicator parameter data obtained from the 8 gpm steady state conditions. Table 8 (see section 5.5.1.1) provides a summary of the steady state data produced for pH, DO, and Eh at each of the flow rates utilized. Appendices B-1 through B-17 provide all the data produced during Phase I deployment / demonstration.

Table 11
 Summary Steady State Inorganic Data
 (Influent / Effluent Data)

Sample Location	Relation to Cell	Date	Flow Rate (gpm)	Lab	Parameter				
					Al	Ca	Fe	Mg	Mn
TCM-2	influent	9/30/97	0.97	ADS	NA	NA	NA	NA	NA
TGSC-1S	effluent	9/30/97	0.97	ADS	<0.216	5.749	0.269	1.048	0.146
TGSC-X8	effluent	9/30/97	0.97	ADS	<0.216	4.579	0.119	0.973	0.007
TCM-2	influent	11/11/97	4	ADS	1.263	5.207	0.115	1.810	0.091
TGSC-1S	effluent	11/11/97	4	ADS	7.775	8.342	1.153	1.175	0.226
TGSC-X8	effluent	11/11/97	4	ADS	8.125	6.480	0.300	1.055	0.176
TCM-2	influent	12/16/97	7.98	ADS	1.974	7.119	0.131	1.578	0.093
TGSC-1S	effluent	12/16/97	7.98	ADS	4.188	5.723	3.526	1.010	0.155
TGSC-X8	effluent	12/16/97	7.98	ADS	12.265	3.556	3.446	0.954	0.162
TCM-2	influent	12/16/97	7.98	GEL	0.107	4.130	0.043	NA	NA
TGSC-1S	effluent	12/16/97	7.98	GEL	<0.050	3.885	4.335	NA	NA
TGSC-X8	effluent	12/16/97	7.98	GEL	<0.050	3.945	2.895	NA	NA

Sample Location	Relation to Cell	Date	Flow Rate (gpm)	Lab	Parameter					
					Na	Si	Zn	Chloride	Nitrate	Sulfate
TCM-2	influent	9/30/97	0.97	ADS	NA	NA	NA	NA	NA	NA
TGSC-1S	effluent	9/30/97	0.97	ADS	7.870	6.430	0.292	2	<1	12
TGSC-X8	effluent	9/30/97	0.97	ADS	7.488	6.932	0.017	2	<1	12
TCM-2	influent	11/11/97	4	ADS	15.988	4.760	0.030	8	49	5
TGSC-1S	effluent	11/11/97	4	ADS	11.923	0.259	0.045	9	<1	3
TGSC-X8	effluent	11/11/97	4	ADS	10.800	0.259	0.031	4	<1	2
TCM-2	influent	12/16/97	7.98	ADS	18.611	4.844	0.060	6.0	<1	11.0
TGSC-1S	effluent	12/16/97	7.98	ADS	10.684	0.826	0.042	4.0	<1	2.0
TGSC-X8	effluent	12/16/97	7.98	ADS	9.577	0.966	0.031	4.0	<1	2.0
TCM-2	influent	12/16/97	7.98	GEL	NA	11.050	0.008	5.630	8.850	11.500
TGSC-1S	effluent	12/16/97	7.98	GEL	NA	2.225	<0.005	4.123	0.020	2.113
TGSC-X8	effluent	12/16/97	7.98	GEL	NA	1.910	0.001	4.040	0.010	1.725

Notes: ADS = SRTC Analytical Development Section; GEL = General Engineering Laboratories, Inc.

Table 12
8 gpm Steady State Average Indicator Parameters
 (GEL Laboratory)

Sample Location	Distance Into Cell (ft)	Gross Alpha (pC/L)	Alkalinity (mg/L)	TSS (mg/L)	TOC (mg/L)	BOD5 (mg/L)
TCM-2	influent	6.45	<5.000	<2.000	8.020	<3.00
TGSC-1S	effluent	0.556	40.333	3.530	3.015	3.00
TGSC-X8	effluent	1.567	34.050	4.300	1.840	2.67

5.5.2.2 Phase I Treatability Test Inorganic Data Evaluation

The inorganic chemistry of the TNX GeoSiphon Cell is dominated by the corrosion of iron (i.e. the oxidation of iron and the reduction of hydrogen), because a total of 49.7 tons of granular cast iron (Fe^0) were utilized within the cell:

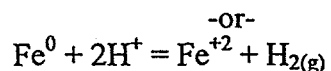
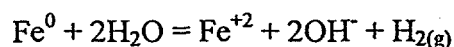

In addition to producing ferrous iron (Fe^{+2}), the corrosion of iron is an acid consuming reaction which typically elevates the pH to between 9 and 10, assuming no other acid producing or consuming reactions occur. Additionally the corrosion of iron causes the Eh (oxidation/reduction potential) to decrease to a level approaching the zero valent iron / ferrous iron couple (Fe^0 / Fe^{+2}) standard potential of -409 mV, assuming no other couples significantly influence the system.

Figure 40 presents the total iron in solution profile for each of the steady state flow rates. As can be seen at all flow rates the influent iron is typically at levels less than 1 ppm, iron corrosion causes immediate peaks in the dissolved iron concentration by the first sample port located within the iron, and the dissolved iron levels generally decline thereafter throughout the iron.

As previously outlined in section 5.5.1.2, Figure 25 presents a comparison of the pH profiles for each of the steady state flow rates along with the laboratory column test profile. As with the laboratory column testing, the pH increased with travel through the granular cast iron in TGSC-1 (see Figure 25). The 1 gpm steady state GeoSiphon pH profile is essentially identical to the laboratory column profile, which showed a pH increase with travel through the iron to a pH of approximately 9. At higher flow rates (i.e. 4 and 8 gpm), pH initially increased rapidly to a value slightly greater than 7 and remained at this value with travel through the iron. The pH profiles at

the higher flow rates appear to be depressed, relative to the column test, the 1 gpm GeoSiphon flow rate, and what would be expected due to iron corrosion alone.

As previously outlined in section 5.5.1.2, Figure 26 presents a comparison of the Eh profiles for each of the steady state flow rates along with the laboratory column test profile. As with the laboratory column testing, the Eh (oxidation/reduction potential) decreased (that is, reducing conditions were produced) with travel through the granular cast iron in TGSC-1 (see Figure 26). A 1 gpm steady state GeoSiphon Eh profile was not produced during this testing, but it is assumed that such a profile would be similar to the laboratory column profile, which showed an Eh decrease with travel through the iron to approximately -300 mV. While both the 4 gpm and 8 gpm steady state GeoSiphon Eh profiles showed a decrease in Eh below influent values, the Eh only decreased to approximately -170 mV and 50 mV, respectively, with travel through the iron. As can be seen in Figure 26, increasing flow rates produced less reduction in Eh with travel through the iron and deviated increasingly from the zero valent iron / ferrous iron couple ($\text{Fe}^0 / \text{Fe}^{+2}$) standard potential of -409 mV.

The above observations associated with soluble iron concentrations, pH, and Eh reflect the occurrence of multiple reactions related to the oxidation of the zero valent iron, the reduction of other constituents, and the subsequent formation of precipitates. The following provides an outline of the anticipated reactions based upon the available data. There is direct evidence for some of these reactions. For others the evidence is less compelling, but they are proposed as possible reactions that explain chemical trends.

As groundwater enters the GeoSiphon, reduction of TCE (Figure 27), nitrate (Figure 41), dissolved oxygen (Figures 17 and 21), and sulfate (Figure 42) are dominant reactions. TCE concentrations (Figure 27) were reduced from ~200 ug/l to below detection (1 ug/l) within the first 1.5 feet of contact with the zero valent iron at all flow rates. At flow rates of 1 and 4 gpm, nitrate concentrations (Figure 41) were reduced from >20 mg/l to below detection (1 mg/l) within the first 0.32 feet of contact with the iron. At all flow rates, sulfate concentrations (Figure 42) were reduced from around 10 to 20 mg/l to less than 1 mg/l within 1 foot of contact with the iron. Concurrently, pH and dissolved iron concentrations increased sharply. This suggests the following reactions, in addition to iron corrosion (oxidation), occur within the first several inches of contact with the iron:

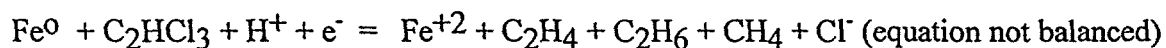

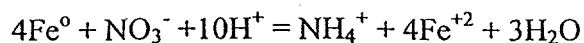

and/or

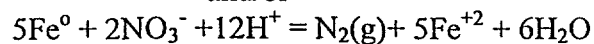

and/or

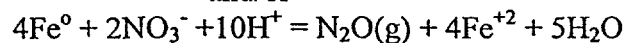

All possible nitrate reduction reactions

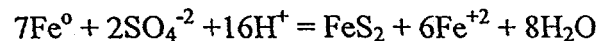
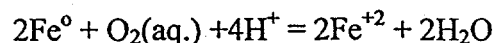

Consumption of acid and production of ferrous iron by these reactions causes the system to exceed saturation with iron carbonate and this phase precipitates by the reaction:

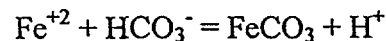

There may be kinetic factors that inhibit the initial precipitation of iron carbonate allowing the dissolved iron concentration and pH to build to high levels in the first few inches of iron. Once precipitation of iron carbonate begins, the dissolved iron concentration is decreased to a level controlled by the iron carbonate equilibrium.

Ferrous iron hydroxide may also precipitate by the reaction:

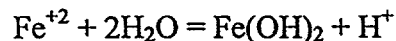

However, thermodynamic constraints suggest the system remains undersaturated with respect to this phase until the pH rises above about 7.4 (assuming $[\text{Fe}^{+2}] = 48 \text{ mg/l}$). Thus, at flow rates of 4 and 8 gpm $\text{Fe}(\text{OH})_2$ would not be expected to precipitate until the pH rises at the final few inches of iron or within the 12 inch screen zone. At 1 gpm, the pH rises enough to cause precipitation of $\text{Fe}(\text{OH})_2$ at about 1 foot within the iron on the upgradient end.

The relative rates of the acid consuming and acid producing reactions control the pH of the system. At flow rates of 4 and 8 gpm the pH remains stable around a value of 7 (see Figure 25). The stable pH across most of the iron at flow rates of 4 and 8 gpm suggest that the acid consumption by the iron corrosion reaction balances the acid production by precipitation of ferrous iron carbonate. At 1 gpm the pH rises to 8.97 at 1.5 feet within the iron (see Figure 25). A relatively higher rate of acid consumption by hydrogen reduction than acid production by iron precipitation would cause this trend. The number of moles of acid that must be consumed to elevate the pH of a liter of water from 6.8 to 9 is 1.6×10^{-7} . This equates to production of 0.0015 mg of excess ferrous iron per liter of water by the hydrogen reduction reaction. Hence, the increase in dissolved iron concentration produced by the increase in the relative rate of hydrogen reduction would not be detectable. A possible reason for the higher pH attained at a 1 gpm relative

to the pH attained at 4 and 8 gpm may be that the mass of dissolved inorganic carbon (carbonate species) is exhausted by precipitation of FeCO_3 within the first 0.5 feet of iron at the lower flow rate. When the dissolved inorganic carbon is depleted, FeCO_3 can no longer precipitate and the pH will continue to rise. If the consumption of dissolved inorganic carbon is slow relative to the 4 and 8 gpm flow rates, then, at these flow rates, precipitation of FeCO_3 can occur throughout the entire flow length of the GeoSiphon Cell. This may limit the pH to a value near 7 for the 4 and 8 gpm tests.

In the final few inches of iron or within the 12 inch screen zone, the pH rises to above 9 for all flow rates. The reason for this is uncertain, but is likely related to the presence of the 12 inch screen zone, which is open to the atmosphere. If water at this location were more oxygenated the following reaction might have occurred.

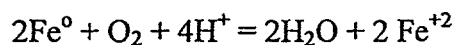

Again, only a small amount of reacted oxygen could raise the pH from 7 to above 9.

The dissolved oxygen measurements (see Figures 17 and 20) are interesting because they don't decrease to the levels expected for a system of zero valent iron and water that is closed to oxygen. The oxidation of the iron should result in dissolved oxygen concentrations below detection. There are three possibilities for the elevated DO measurements. It is possible that there was a consistent degree of atmospheric contamination during sampling. However, this seems unlikely and the degree of contamination would have to have changed for the initial samples at TGSC-1A and the final samples at TGSC-1S and TGSC-X8. Another possibility is that the system is not closed to atmospheric oxygen, in which case a dissolved oxygen concentration of 2 mg/l could be maintained. A third possibility is that another dissolved gas, produced during reaction with the iron, interferes with the measurement of dissolved oxygen. Membrane probes used for the measurement of dissolved oxygen are sensitive to other dissolved gases, particularly those that are easily ionizable. A possible interfering gas would be nitrous oxide (N_2O), produced by the reduction of nitrate.

As stated previously, Eh measurements (see Figure 26) are also higher than expected for the zero valent iron/ferrous iron couple. At 8 gpm the Eh remains between 0 and +100 mV throughout the zero valent iron. At 4 gpm it decreases to between -100 and -200 mV, but does not approach -409 mV, the standard potential of the zero valent iron/ferrous iron couple. This is a reflection of the presence of other redox couples in the system. The standard potential of the $\text{H}_2/2\text{H}^+$ couple is defined as 0 mV, the standard potential of the nitrate/ammonia couple is +810 mV, and the standard potential of the sulfate/sulfide couple is approximately +250 mV. Eh is a measure of the composite potential of the dissolved constituents of the many redox couples. Therefore, if the $\text{H}_2/2\text{H}^+$, the nitrate/ammonia, and the sulfate/sulfide couples exert an influence on the Eh measurement, it may be greater than that expected for the zero valent iron/ferrous iron couple.

Other constituents show patterns of increase or decrease along the flow path within the iron. Concentrations of calcium (Figure 43) and magnesium (Figure 44) vary and may reflect the presence of soil clays or bentonite within or close to the iron. The high initial concentrations of sodium (Figure 45) and aluminum (Figure 46; 4 gpm test only) probably do represent the influence of the bentonite seal. The concentrations decrease sharply within the iron. Manganese concentrations (Figure 47) significantly increase over influent concentrations at all flow rates followed by lower but still elevated concentrations at the cell's effluent. This manganese increase may be due to the oxidation of Mn^0 to Mn^{+2} from the granular cast iron which contains 0.56 wt. % Mn.

The initial concentrations of silica (Figure 48) are typical of SRS groundwater, near saturation with amorphous silica. They drop sharply during the first few inches of contact with the iron. In the 1 gpm test the silica concentration then rises as pH rises. In the 4 and 8 gpm tests the silica concentrations continue to decrease to less than 1 mg/l. The solubility of silica remains relatively constant with increasing pH, until pH exceeds about 8. Above this pH silica solubility increases. An analysis of the iron provided with the water chemistry data shows that the iron contains 2.34 wt.% Si. Thus, it is possible that the increase in silica concentration during the 1 gpm test is the result of dissolution of silica associated with the zero valent iron. The decreasing silica concentrations during the 4 and 8 gpm tests suggest that silica is precipitating rather than dissolving at the lower pH achieved during these tests. The mineral titanite ($CaTiSiO_5$) was identified by x-ray diffraction in a sample of sludge taken from the 12 inch screen zone following the 1 gpm test (see discussion below). Though titanite is common in soils, the relative abundance in the sludge sample was greater than in most soils. In addition to silica, the zero valent iron also contains 0.0156 wt. % titanium. Thus, it is possible that the initial decrease in silica concentration in all of tests reflects the precipitation of titanite.

X-Ray Diffraction (XRD) analyses of two sludge samples from the TNX GeoSiphon Cell were conducted. The first sludge sample was collected from the central 12 inch diameter screen zone on 10/15/97 after completion of the 1 gpm test and initiation of the 4 gpm test. A sample of the approximately 9 inches of sludge found at the bottom of the 12 inch diameter screen zone was collected. Figure 49 is the diffractogram showing the results of this analysis. The major crystalline compounds detected by the XRD analysis include: pyrite (FeS_2), quartz (SiO_2), illite, titanite ($CaTiSiO_5$), and kaolinite. XRD analyses are not quantitative and can not detect amorphous (i.e. non-crystalline) solids.

Quartz, illite, and kaolinite are among the most abundant minerals in SRS soils. They were not produced due to the zero valent iron degradation process, but are most likely within the screen zone as a result of the GeoSiphon Cell installation process, which did not include any type of development prior to start up. The percentage of expected titanite ($CaTiSiO_5$) peaks matched on the X-Ray Diffraction pattern of the fine grained sludge is lower than the other phases identified.

Therefore, its positive identification is less certain than the other phases. Titanite is a common minor phase in SRS soils and could have been introduced into the screen zone during GeoSiphon Cell installation. However, titanite's apparent abundance is somewhat peculiar suggesting the possibility that it may have precipitated as a result of the relatively high pH in the GeoSiphon Cell. Pyrite occurs naturally in SRS soils and may be common in the organic-rich soils of the TNX swamps. However, as groundwater passes through the GeoSiphon, the zero valent iron appears to cause the reduction of sulfate to sulfide which results in the precipitation of pyrite.

The second sludge sample was collected from the discharge piping after 10/15/97 after completion of the 1 gpm test and initiation of the 4 gpm test. Figure 50 is the diffractogram showing the results of this analysis. The major crystalline compounds detected by the XRD analysis were ferric oxy-hydroxide phases. A distinct change in the color of the sludge from black to orange occurred between the time the sample was obtained and the time of its analysis. This is consistent with deposition of ferrous (Fe^{+2}) iron hydroxides in the discharge piping followed by oxidation to ferric (Fe^{+3}) oxy-hydroxide.

5.5.2.3 Phase I Treatability Test Inorganic Results as Related to Long Term Performance

While Phase I testing does not constitute an evaluation of the long term performance issues associated with use of the TNX GeoSiphon Cell and its granular cast iron treatment media, EnviroMetal Technologies, Inc. (ETI) and the University of Waterloo have conducted studies to address the long term performance issues associated with the use of granular cast iron. The following is a summary of information provided by ETI concerning their studies. The original letter from ETI is provided as Appendix D.

"...The issue of long term performance in granular iron treatment systems usually focuses on the formation of mineral precipitates, which may cause a decline in hydraulic conductivity and porosity over time. Results to date indicate that the reactivity of the iron should be maintained for several years to decades, even in areas where precipitates occur." Analyses of iron cores from both laboratory columns and field sites have been conducted. The following precipitates and their location of precipitation have been identified from these analyses:

- Calcium carbonate has been identified "in the iron material at the upgradient edge of the treatment wall."
- Iron hydroxide ($\text{Fe}(\text{OH})_2$) and magnetite (Fe_3O_4) have been identified within the iron treatment media. It is assumed that "some iron hydroxides may be converted over time to" magnetite.

Other precipitates which are considered likely but have not been identified from iron core analyses include:

- Ferrous carbonate (FeCO_3)
- Magnesium carbonate (MgCO_3)
- Pyrite (FeS_2)

Most of the carbonate precipitation is anticipated at the upgradient edge of the iron treatment media. "Most of the iron produced due to corrosion" is anticipated to precipitate within "the iron treatment zone itself."

In addition these core analyses and associated studies have revealed the following:

- After eighteen month's to two year's of operation, porosity losses in the range of 10% at the upgradient edge of the iron treatment media declining to below 2% within the first foot of iron have been detected.
- "Consistent organic degradation has been observed" in spite of porosity losses.
- No evidence of biofouling has been observed.

5.5.2.4 Phase I Treatability Test Inorganic Summary

In conclusion, the chemical composition of water that passes through the GeoSiphon Cell reflects the occurrence of several reactions. These reactions are dominated by the corrosion of iron (i.e. the oxidation of the zero valent iron and the reduction of hydrogen). Other modifying reactions include the reduction of the CVOCs, nitrate, dissolved oxygen, and sulfate, and the precipitation of pyrite (FeS_2), ferrous iron carbonate (FeCO_3), ferrous iron hydroxide ($\text{Fe}(\text{OH})_2$), and potentially titanite (CaTiSiO_5). The pyrite, ferrous iron carbonate, and titanite are most likely to precipitate within the iron treatment zone itself. The ferrous iron hydroxide is most likely to precipitate within the 12 inch screened zone, which is exposed to the atmosphere (at lower flow rates the ferrous iron hydroxide may precipitate within the iron treatment zone itself). XRD analysis of a sludge sample taken from the sump of the central 12 inch screen zone is consistent with precipitation of pyrite and titanite. XRD analysis of a sludge sample from the discharge piping is consistent with precipitation of ferrous hydroxide.

As summarized by ETI based upon their independent studies "...the issue of long term performance in granular iron treatment systems usually focuses on the formation of mineral precipitates, which may cause a decline in hydraulic conductivity and porosity over time. Results to date indicate that the reactivity of the iron should be maintained for several years to decades, even in areas where precipitates occur."

5.5.3 Phase I Treatability Test Miscellaneous Results

The following miscellaneous tests were conducted during the Phase I testing:

- Microbial densities from water samples taken from selected sampling ports
- Toxicity test from a water sample taken from sample location TGSC-X8

5.5.3.1 Phase I Treatability Test Microbial Density Results

Water samples from selective sampling ports in and around the GeoSiphon Cell were taken on January 21, 1998 for microbial density tests, while the GeoSiphon Cell was flowing at a rate of approximately 7.1 gpm. The samples were stored at 4°C until sample preparation was performed. Sample preparation consisted of vortexing each sample container for 30 seconds and spotting 50 µl of sample into each well of an alcohol rinsed toxoplasmosis microscope slide placed on a 65 °C hot plate. All samples were then heat fixed for 12 to 15 minutes. After heat fixing the sample, the slide was removed from the hot plate and stained with 4-6-diamidino-2 phenylindole (DAPI), a DNA fluorochrome stain for 5 minutes. Each slide was rinsed with filtered deionized water and allowed to air dry. The slides were examined using a Zeiss fluorescent microscope. The microscope's field of view was calibrated using a micrometer and the microbial densities were calculated based on the number of cells counted, area of the field, area of the toxoplasmosis well, and the volume of water spotted on the slide. A duplicate count was performed on sample TGSC-1B using 10 µl of sample, because of its higher microbial density.

Table 13 and Figure 51 provide the results of the microbial density tests. The microbial density of the groundwater (i.e. TCM-2 and TGSC-1A) was very low. The microbial density within the cell itself significantly increased over the groundwater levels. Sample port TGSC-1B, which is approximately 0.14 feet into the iron, had the highest microbial density at approximately three orders of magnitude greater than the groundwater levels. Thereafter the microbial density decreased with travel distance through the iron (i.e. TGSC-1E and TGSC-1H) to levels approximately one order of magnitude greater than groundwater levels. The microbial density appeared to slightly increase again once the treated groundwater exited the iron treatment media and entered the TGSC-1 12 inch diameter central screen. Although the microbial densities significantly increased at the entrance to the GeoSiphon Cell iron treatment zone, the levels were still comparatively low and are not expected to produce biofouling. Typical microbial densities required to produce biofilms is on the order of 1E+09 to 1E+10 cells/ml, which is three to four orders of magnitude greater than those seen within the GeoSiphon Cell. Additionally the increase and subsequent decrease in microbial density through the GeoSiphon Cell correlates well with the degradation of TCE (compare Figures 27 and 51). The highest microbial densities appear where the greatest magnitude of TCE degradation occurs. This may mean that the presence of the microbes actually increases the efficiency of the GeoSiphon Cell by their scavenging the TCE degradation products such as methane.

Table 13
Microbial Density Results

Sample Port	Distance into Cell (ft)	Microbial Density (# cells/ml)	Standard Error (# cells/ml)
TCM-2	0 ¹	3.60E+03	+/- 2.00E+02
TGSC-1A	0 ¹	1.77E+03	+/- 2.91E+02
TGSC-1B	0.14	3.10E+06	+/- 4.77E+04
TGSC-1B (duplicate)	0.14	2.79E+06	+/- 3.10E+05
TGSC-1E	1.07	8.04E+04	+/- 1.84E+03
TGSC-1H	2.86	1.81E+04	+/- 1.44E+03
TGSC-1S	- ³	4.09E+04	+/- 1.49E+03
TGSC-1 ²	- ³	4.38E+04	+/- 2.74E+03

Notes:

¹ These samples are from the influent side of the GeoSiphon Cell.

² This sample was taken approximately six inches from the bottom of the TGSC-1 12 inch diameter central screen.

³ These samples are from the effluent side of the GeoSiphon Cell.

5.5.3.2 Phase I Treatability Test Toxicity Test Results

Water samples from the TGSC-X8 sampling location (GeoSiphon effluent) were taken on January 14, 1998, while the GeoSiphon Cell was flowing at a rate of approximately 7.2 gpm, for two non-compliance *Ceriodaphnia Dubia* acute toxicity tests. The samples were shipped to Shealy Environmental Services, Inc. for the *Ceriodaphnia Dubia*, 48 hour, static, acute toxicity tests at an in stream waste concentration (IWC) of 33% (i.e. 33% GeoSiphon effluent and 67% dilution water). One test utilized SRS dilution water, and the other test utilized moderately hard synthetic water. The GeoSiphon effluent passed both tests, with a 0% mortality rate for both the control and the GeoSiphon effluent. This means that the GeoSiphon effluent is not considered toxic. Appendix E presents the results of the toxicity tests as received from the laboratory.

5.5.3.3 Phase I Treatability Test Miscellaneous Results Summary

The following are the results of the miscellaneous tests that were conducted during the Phase I testing:

- Microbial densities were determined from water samples taken from selected sampling ports in and around the GeoSiphon Cell. Microbial densities significantly increased from groundwater levels at the entrance to the GeoSiphon Cell iron treatment zone and then decreased through the rest of the cell, approaching groundwater levels. All microbial densities recorded were comparatively low and are not expected to produce biofouling. In fact the microbes may actually increase the efficiency of the GeoSiphon Cell by scavenging the TCE degradation products such as methane.
- The GeoSiphon effluent passed two *Ceriodaphnia Dubia*, 48 hour, static, acute toxicity tests, indicating that the effluent is not considered toxic.

6.0 PHASE I PUMP TEST

6.1 PHASE I PUMP TEST DESIGN

Figure 6 is a well location map which shows the relationship between TGSC-1 and observation wells TCM-2, TNX-11D, and TCM-1. Figure 8 is an as-built schematic of TGSC-1 which shows the location of observation well TGSC-1Z relative to TGSC-1. TGSC-1Z is actually installed within the granular cast iron treatment media. Table 14 provides a listing of the observation wells which will be used, well construction details, and distance from TGSC-1.

Table 14
TGSC-1 Observation Wells Construction Details

Well Id	Coordinates (ft)	Elevation (ft-msl)				Casing Diameter	Aquifer	Distance to TGSC-1
		TOR	TOC	TOS	BOS			
TCM-2	N71142.43 E16199.68	-	99.02	94.02	74.02	4"	WT	24.7'
TNX-11D	N71199.3 E16165.5	100.3	99.8	93.2	73.2	4"	WT	50.2
TGSC-1Z ¹	N71150.54 E16173.22	-	100.06	87.64	86.64	2"	WT	3.0
TCM-1	N71151.65 E16199.44	-	99.21	71.43	68.93	2"	WT	23.3
TGSC-1	N71150.24 E16176.21	-	100.19	90.9	76.9	12"	WT	0'
Savannah River		-		-	-	-	-	

Notes:

TOR = top of riser; TOC = top of casing; TOS = top of screen; BOS = bottom of screen; WT = water table aquifer

¹TGSC-1Z is actually installed within the granular cast iron treatment media of the GeoSiphon Cell.

The Phase I pump test was conducted concurrently with the Phase I treatability tests reported in section 5.0. The flow rates were determined on the basis of treatability (i.e. ability to meet PDWS-MCLs), rather than optimum flow rates for conducting a pump test. The following flow rates and durations were utilized:

- 1 gpm from August 5 to September 30, 1997
- 4 gpm from September 30 to November 11, 1997
- 8 gpm beginning on November 11 to December 16, 1997

The extracted water, which was treated as it flowed through the granular cast iron, was immediately discharged into the TNX NPDES X-08 outfall in a manner that minimized erosion and prevented leaks to the surrounding ground surface.

The following equipment was utilized in the test (Figure 10 provides a schematic of the pump test setup):

- Grundfos 10S05-9 (½ HP, 1 phase, 230 volts, 3-wire) submersible pump
- 6 pressure transducers
- Two Campbell data loggers with internal clocks
- One electric water level tape
- One Fischer & Porter magnetic flow meter installed on the discharge piping
- One Vaisala Barometric Pressure Sensor

Pre-test water level measurements in each observation well and at the Savannah River were taken with transducers and recorded on data loggers every 15 minutes for several days prior to test initiation. Barometric pressure measurements were also taken at the same frequency as the water level measurements.

During the pump tests, TGSC-1 was pumped and water level measurements of TGSC-1, the observation wells (see Table 14), and the Savannah River were taken with transducers and recorded on a data logger. Data logger measurements were taken at a constant interval of every 15 minutes during the test.

6.2 PHASE I PUMP TEST DATA ANALYSIS METHOD

Selected data produced from the pump test was analyzed utilizing AQTESOLV for Windows Version 1.17. The pumping data was analyzed as unsteady flow to a partially penetrating pumping well in an unconfined aquifer with delayed gravity response with partially penetrating observation wells per Neuman's method.

[Neuman, 1975; Freeze and Cherry, 1979; Fetter, 1988]

6.3 PHASE I PUMP TEST RESULTS

Since the Phase I pump test was conducted concurrently with the Phase I treatability tests, and since the flow rates utilized were determined on the basis of treatability rather than optimum flow rates for conducting a pump test, the hydraulic response of the TNX GeoSiphon Cell and its observation wells was reviewed to determine a suitable data set for analysis utilizing AQTESOLV. Figure 52 provides a graphical depiction of the hydraulic response of TGSC-1 and two of its observation wells (TCM-1 and TCM-2) versus pumpage and rainfall. As can be seen both pumpage of TGSC-1 and rainfall produce an immediate response in TGSC-1 and its observation wells. The 1 gpm test data had significant daily fluctuations due to input voltage fluctuations versus drawdown, which rendered the 1 gpm unsuitable for analysis utilizing AQTESOV. Significant rainfall events immediately preceded the start of the 4 gpm test, and separation of the resulting water elevation decreases into the separate components of rainfall dissipation and actual drawdown due to the increased flow rate can not be performed. Only at the initiation of the 8 gpm testing is the data suitable for analysis utilizing AQTESOLV. No significant rainfall preceded the 8 gpm test for approximately a week, and all drawdown noted immediately after initiation of the 8 gpm flow rate can be attributable to the increased flow rate. The suitable data is limited to less than a day's worth of data due to a subsequent rainfall event the next day after the flow increase.

The data utilized for analysis was collected from November 11, 1997 at 3:30 p.m. to November 12, 1997 at 9:30 a.m. The baseline water elevation utilized to determine the associated drawdowns was the 4 gpm test elevation collected immediately prior to initiation of the 8 gpm test on November 11, 1997 at 3:15 p.m. The flow rates utilized in the analysis were obtained by subtracting the average flow rate of 3.997 gpm recorded immediately prior to initiation of the 8 gpm test from the 8 gpm test recorded flow rates. All the observation wells (see Table 14) are considered to be within the water table aquifer. The top of the aquitard elevation was determined from the results of soil boring TNX-PH, which indicated that the aquitard was located at an elevation of approximately 49 ft-msl. The initial water table elevation was taken as approximately 91 ft-msl. Therefore the thickness of the water table aquifer was taken as approximately 42 ft.

Figures 53, 54, 55, and 56 show the time drawdown data recorded from the transducers and data logger versus the Neuman curve match produced by the AQTESOLV runs for observation wells TCM-2, TCM-1, TNX-11D, and TGSC-1Z, respectively.

The aquifer parameters produced from these runs are summarized in Table 15. The horizontal (K_h) and vertical (K_v) hydraulic conductivities calculated from these aquifer parameters are presented in Table 16. Appendix F provides the input and output data from each AQTESOLV run.

Table 15
 Aquifer Parameters - Pump Test (AQTESOLV Neuman Method)

Observation Well	T (ft ² /min)	S	S _y	β
TCM-2	0.8936	0.1187	0.2816	0.01452
TCM-1	0.5498	0.06507	0.3302	0.03269
TNX-11D	0.2674	0.01788	0.2631	0.104
Average	0.5703	0.06722	0.2916	-
TGSC-1Z ¹	0.6674	0.2	0.6312	0.0002004

T = Transmissivity; S = Storativity; S_y = Specific Yield; $\beta = r^2 K_v / b^2 K_h$; r = distance from pumping well; K_h = horizontal hydraulic conductivity; b = water table aquifer thickness; K_v = vertical hydraulic conductivity

¹ TGSC-1Z was actually installed within the granular cast iron treatment media of the GeoSiphon Cell. Convergence utilizing the default AQTESOLV convergence criteria was not obtained for this observation well; the data in the table represents the last iteration of the last AQTESOLV run made.

Table 16
 Hydraulic Conductivity - Pump Test

Observation Well	K _h (ft/day)	K _v (ft/day)	K _h /K _v
TCM-2	30.6	1.3	23.5
TCM-1	18.8	2.0	9.4
TNX-11D	9.2	0.67	13.7
Average	19.5	1.3	15.0
TGSC-1Z ¹	22.9	0.90	25.4

K_h = horizontal hydraulic conductivity; K_v = vertical hydraulic conductivity; $K_h = T / 42$ ft; $K_v = \beta b^2 K_h / r^2$; r = distance from pumping well (see Table 13); b = water table aquifer thickness (42 ft)

¹ TGSC-1Z was actually installed within the granular cast iron treatment media of the GeoSiphon Cell. Convergence utilizing the default AQTESOLV convergence criteria was not obtained for this observation well; the data in the table represents the last iteration of the last AQTESOLV run made.

Convergence utilizing the default AQTESOLV convergence criteria for observation wells TCM-2, TCM-1, and TNX-11D was obtained. Observation wells TCM-2, TCM-1, and TNX-11D are representative of the conditions of the upper part of the water table aquifer in the TNX flood

plain. The AQTESOLV runs for these observation wells produced the following average parameter values:

- Horizontal hydraulic conductivity (K_h) \cong 20 ft/day
- K_h / K_v ratio \cong 15
- Specific yield (S_y) \cong 0.29
- Storativity (S) \cong 0.067

The lower part of the water table aquifer (i.e. elevation 49 feet to 68 feet) was not evaluated during the Phase I testing and likely has a different hydraulic conductivity and K_h / K_v ratio than the upper part which was evaluated.

The average aquifer parameter values were utilized to estimate the radius of influence of the GeoSiphon Cell at various flow rates utilizing AQTESOLV. Defining the radius of influence as a drawdown of 0.1 ft after an elapsed time of approximately 70 days resulted in a radius of influence of approximately 50 ft, 500 ft, and 1000 ft, respectively, for flow rates of 1 gpm, 4 gpm, and 8 gpm. The radius of influence is not identical to the zone of capture; the zone of capture will be less than the radius of influence, and it will be determined during Phase II. Table 17 provides additional GeoSiphon Cell drawdown estimates based upon the average aquifer parameter values.

Table 17
Estimated TGSC-1 Drawdown

Elapsed Time (days)	Flow Rate (gpm)	Drawdown at r = 5ft (ft)	Drawdown at r = 50ft (ft)	Drawdown at r = 500ft (ft)	Drawdown at r = 1000ft (ft)
1.2	1	0.109	0.042	-	-
6.2	1	0.129	0.060	-	-
69.4	1	0.176	0.088	-	-
1.2	4	0.435	0.170	0.000	-
6.2	4	0.516	0.240	0.0186	-
69.4	4	0.706	0.353	0.099	-
1.2	8	0.869	0.340	0.000	0.000
6.2	8	1.033	0.480	0.037	0.001
69.4	8	1.411	0.705	0.197	0.089

Notes to Table 17: r = radius for TGSC-1; Elapsed Time = time since pumping at that flow rate began. It assumes no flow prior to initiation of that flow rate.

Convergence for TGSC-1Z, which was actually installed within the granular cast iron treatment media of the GeoSiphon Cell was not obtained. The data presented below and in Tables 15 and 16 for this observation well represents the last iteration of the last AQTESOLV run made for that well:

- Horizontal hydraulic conductivity (K_h) \cong 23 ft/day
- K_h / K_v ratio \cong 25
- Specific yield (S_y) \cong 0.63

The following comments are applicable to the above values produced for the granular cast iron:

- The hydraulic conductivity produced from the laboratory study for the granular cast iron was approximately 220 ft/day. This laboratory produced hydraulic conductivity is approximately 10 times that of the field produced value. This could be due to the presence of formation fines in the field installed iron and/or the inapplicability of the AQTESOLV analysis to TGSC-1Z due to its and the GeoSiphon Cell's configuration.
- The K_h / K_v ratio of approximately 25 appears high due to the narrow particle size range of the granular cast iron (i.e. 0.25 to 2 mm).
- The specific yield of 0.63 appears to be reasonable, since the in placed porosity of the GeoSiphon Cell granular cast iron is approximately 68 percent.

In addition to the determination of the aquifer parameters from the TGSC-1 hydraulic response data, the water level elevations at TGSC-1 have been compared to those of the Savannah River in Figure 57. Figure 58 presents the head differential between TGSC-1 and the Savannah River. The following average head differentials were noted for each flow rate:

<u>Flow Rate</u> (gpm)	<u>Average Head</u> <u>Differential</u> (ft)
1	7.59
4	7.19
8	5.88

These average head differentials are sufficient to drive siphon flows at the respective flow rates.

6.4 PHASE I PUMP TEST SUMMARY

Observation wells TCM-2, TCM-1, and TNX-11D are representative of the conditions of the upper part of the water table aquifer in the TNX flood plain. The average aquifer parameters produced from these observation wells were:

- Horizontal hydraulic conductivity (K_h) \cong 20 ft/day
- K_h / K_v ratio \cong 15
- Specific yield (S_y) \cong 0.29
- Storativity (S) \cong 0.067

The lower part of the water table aquifer (i.e. elevation 49 feet to 68 feet) was not evaluated during the Phase I testing and likely has a different hydraulic conductivity and K_h / K_v ratio than the upper part which was evaluated.

Based upon the average aquifer parameters, the radius of influence of the TNX GeoSiphon Cell was estimated to be approximately 50 ft, 500 ft, and 1000 ft, respectively, for flow rates of 1 gpm, 4 gpm, and 8 gpm (with the radius of influence defined as a drawdown of 0.1 ft after an elapsed time of approximately 70 days). The radius of influence is not identical to the zone of capture; the zone of capture will be less than the radius of influence, and it will be determined during Phase II.

7.0 PRELIMINARY MODELING

7.1 PHASE I PRELIMINARY MODEL

The 1997 TNX flow and contaminant transport model was utilized to provide an estimate of the maximum TCE contaminant profile over time along the assumed line of potential full scale GeoSiphon Cell deployment (i.e. along the line of wells TNX-8D through TNX-12D, which are approximately along plant coordinate E16170). In order to perform this estimation the model was modified as follows:

- The existing TNX pump and treat system operation began in October, 1996 and was shut down in January, 2000 (assumed start of full scale GeoSiphon Cell system).
- The actual pumping rates of the pump and treat system recovery wells were utilized as follows:
 - Recovery well TRW-1 at 20.7 gpm
 - Recovery well TRW-2 at 18.8 gpm
 - Recovery well TRW-3 at 14.9 gpm
 - Recovery well TRW-4 at 5.7 gpm

No sensitivity analyses or recalibration of the existing model was performed for this estimation.

7.2 PHASE I PRELIMINARY MODELING RESULTS

Figures 59 and 60 present a summary of the results of this modeling effort. Figure 59 presents both the modeled and actual 1997 TCE profiles along the line of wells TNX-8D through TNX-12D. The modeled profiles include both the TCE concentration averaged over elevations 70 to 94 ft-msl and the maximum TCE concentration modeled over those same elevations. The actual profile was taken from the second quarter 1997 TCE data from wells TNX-8D through TNX-12D and well TCM-2. All these wells have 20 foot screen zones, and therefore data from these wells produce depth averaged results. As can be seen the magnitude of the actual data matches well the magnitude of the averaged modeled results. However both the averaged and maximum modeled results produced a plume that was much wider than the actual plume width particularly in the direction of the X-08 outfall ditch. Additionally the modeled results produced a maximum plume thickness of approximately 47 feet (i.e. from an elevation of 94 ft-msl to 47 ft-msl); whereas the actual plume thickness is approximately 20 feet (i.e. from an elevation of ~94 ft-msl to ~74 ft-msl; see Figure 7). The following is the maximum concentration and its associated location associated with each profile:

- The averaged modeled result profile had a maximum TCE concentration of 240 ppb at plant coordinate N71250, E16170.
- The maximum modeled result profile had a maximum TCE concentration of 382 ppb at plant coordinate N71250, E16170.
- The actual result profile had a maximum TCE concentration of 244 ppb at plant coordinate N71250, E16170.

Figure 60 presents the averaged modeled TCE concentrations at a point in the plume over time. The point presented represents the TCE concentration averaged over elevations 70 to 94 ft-msl at the maximum modeled result profile location (N71250, E16170). Based upon the model results, it can be seen that the current model predicts that TCE concentrations at this point will decrease with time. This decrease over time shown in Figure 60 is representative of all other modeled points along the line of wells TNX-8D through TNX-12D. This means that the current actual concentrations should be the maximum concentrations which a potential full scale GeoSiphon Cell system (along the line of wells TNX-8D through TNX-12D) would have to treat.

7.3 PHASE I PRELIMINARY MODELING SUMMARY

The preliminary modeling produced maximum TCE concentrations similar to those produced from actual monitoring wells, however the modeled plume width was significantly wider and thicker than the actual monitored width and thickness, particularly in the direction of the X-08 outfall ditch. Additionally the modeling indicated that the current actual concentrations should be the maximum concentrations which a potential full scale GeoSiphon Cell system would have to treat.

8.0 CONCLUSIONS AND RECOMMENDATIONS

Results from Phase I testing indicate that the degradation of TCE, itself, is the limiting compound to treatment below the PDWS-MCLs within the TNX GeoSiphon Cell. The data also indicates that a maximum flow rate of between 7.8 gpm and 8.3 gpm can be treated while maintaining the average discharge TCE concentration below 5 ug/l. Additionally the average TCE first order rate constants (k) produced from the steady state TCE data increased with increasing flow from 0.347 /hr at 1 gpm to 0.917 /hr at 8 gpm, and the associated half-lives ($t_{1/2}$) decreased with increasing flow from 2.0 hrs at 1 gpm to 0.76 hrs at 8 gpm.

It was also observed that while the geonet with geotextile may produce a more even distribution of the contaminants over the granular cast iron cylinder surface area than exists within the formation itself, it does not completely average out the formation distribution over the iron surface area (i.e. the contaminant influent profile to the GeoSiphon Cell treatment media is still significantly stratified).

The primary concern associated with the long term performance of granular cast iron treatment systems is that of mineral precipitation. Such precipitation may cause a decline in hydraulic conductivity and porosity over time and may block active CVOC reduction sites on the iron surface. While Phase I testing did not directly address the issue of long term performance, the primary precipitates which are likely to form within the TNX GeoSiphon Cell were identified as pyrite (FeS_2), ferrous iron carbonate (FeCO_3), ferrous iron hydroxide ($\text{Fe}(\text{OH})_2$), and potentially titanite (CaTiSiO_5). These precipitates are similar to those documented in other granular cast iron treatment systems. EnviroMetal Technologies, Inc. indicated that results to date from other granular cast iron treatment systems "indicate that the reactivity of the iron should be maintained for several years to decades, even in areas where precipitates occur."

Two miscellaneous tests were conducted during the Phase I testing. In the first miscellaneous test, microbial densities were determined from water samples taken from selected sampling ports. Microbial densities significantly increased from groundwater levels at the entrance to the GeoSiphon Cell iron treatment zone and then decreased through the rest of the cell, approaching groundwater levels. All microbial densities recorded were comparatively low and are not expected to produce biofouling. In fact the microbes may actually increase the efficiency of the GeoSiphon Cell by scavenging the TCE degradation products such as methane. The second miscellaneous test consisted of two *Ceriodaphnia Dubia*, 48 hour, static, acute toxicity tests of the GeoSiphon Cell effluent. The effluent passed the toxicity tests, indicating that the effluent is not considered toxic.

Additionally during Phase I testing a horizontal hydraulic conductivity (K_h) of approximately 20 ft/day, a horizontal to vertical hydraulic conductivity ratio (K_h/K_v) of approximately 15, a specific yield (S_y) of approximately 0.29, and a storativity (S) of approximately 0.067 were produced from the Phase I hydraulic data. Based upon these average aquifer parameters, the radius of influence of the TNX GeoSiphon Cell was estimated to be approximately 50 ft, 500 ft, and 1000 ft, respectively, for flow rates of 1 gpm, 4 gpm, and 8 gpm (with the radius of influence defined as a drawdown of 0.1 ft after an elapsed time of approximately 70 days).

Also preliminary flow and contaminant transport modeling was conducted to provide an estimate of the maximum TCE contaminant profile in the location of potential full scale GeoSiphon Cell deployment. The preliminary modeling produced maximum TCE concentrations similar to those produced from actual monitoring wells, however the modeled plume width and thickness was significantly wider and thicker than that actually monitored, particularly in the direction of the X-08 outfall ditch. Additionally the modeling indicated that the current actual concentrations should be the maximum concentrations which a potential full scale GeoSiphon Cell system would have to treat.

Based upon the favorable results to date, the following recommendations are made:

- The Phase II siphon line should be installed and that Phase II testing should be conducted. Phase II testing consists of the induction of flow through the TNX GeoSiphon Cell (TGSC-1) by siphon for direct discharge to the Savannah River. This phase will determine the acceptable siphon flow rates, determine the required cell spacing, and demonstrate the overall concept and functionality. All necessary permitting for installation of the Phase II siphon line has been obtained, and all necessary CERCLA approvals for Phase II testing were obtained at the same time that approval was obtained for Phase I (see section 3.6).
- GeoSiphon Design modifications should be considered to account for the significant influent stratification to the existing GeoSiphon Cell.
- The current TNX flow and contaminant transport model should be modified based upon the measured hydraulic properties of the water table aquifer in the flood plain, the actual TCE concentrations within the plume, and the actual width and thickness of the plume in the flood plain.
- Consideration should be given to additional characterization within the TNX flood plain aimed at defining the actual width of the plume (i.e. additional characterization primarily between monitoring wells TNX-10D and TNX-9D but also between monitoring well TNX-11D and the X-08 outfall ditch).
- Consideration should be given to additional microbial studies within Phase II testing.

REFERENCES

Edwards, J. R. (1984). "Unique Siphon Well System for Dewatering Overburden on Limestone in the Central Phosphate District of Florida," *Hydrogeology of Karstic Terrains: Case Histories*, Vol. 1, pp. 180-184.

EPA/600/F-97/008. Permeable Reactive Subsurface Barriers for the Interception and Remediation of Chlorinated Hydrocarbon and Chromium (VI) Plumes in Ground Water. U. S. EPA Remedial Technology Fact Sheet

ETI Reference: 31054.10, EnviroMetal Technologies, Inc., "Feasibility Study Report, CVOC Iron Degradation Study Using Groundwater from the TNX Area, Savannah River Technology Center, Aiken, South Carolina," July 1996.

Fetter, C. W. (1988). Applied Hydrogeology, Macmillan Publishing Company, New York.

Freeze, R. A. and Cherry, J. A. (1979). Groundwater, Prentice-Hall, Inc., Englewood Cliffs, N.J.

Gibson, A. H. (1961). Hydraulics and Its Applications, Constable & Company LTD, London.

Gillham, R. W. and O'Hannesin, S. F. (1994). "Enhanced Degradation of Halogenated aliphatics by Zero-Valent Iron," *Ground Water*, Vol. 32, No. 6, November-December, 1994, pp. 958-967.

Loitz, D. B., de Steiguer, A. L., and Broz, W. R. (1990). "Siphon Quenches," *Civil Engineering*, Vol. 60, No. 8, August, 1990, pp. 44-46.

Mathur, J. (1990). "Draw some Help from Hydraulic Grade Lines," *Chemical Engineering Progress*, October, 1990, pp. 50-54.

Neuman, S. P. (1975). "Analysis of Pumping Test Data from Anisotropic Unconfined Aquifers Considering Delayed Gravity Response," *Water Resources Research*, Vol. 11, No. 2, pp. 329-342.

O'Hannesin, S. F. and Gillham, R. W. (1998). "Long-term Performance of an In situ "Iron Wall" for Remediation of VOCs," *Ground Water*, Vol. 36, No. 1, pp. 164-170.

SRT-ESS-96-365, M. A. Phifer, "Permeable Wall Laboratory Study Final Report," August 6, 1996.

Tratnyek, P. G., Johnson, T. L., Scherer, M. M., and Eykholt, G. R. (1997). "Remediating Ground Water with Zero-Valent Metals: Chemical considerations in Barrier Design," *Ground Water Monitoring Review*, Fall 1997, pp. 108-114.

FIGURES

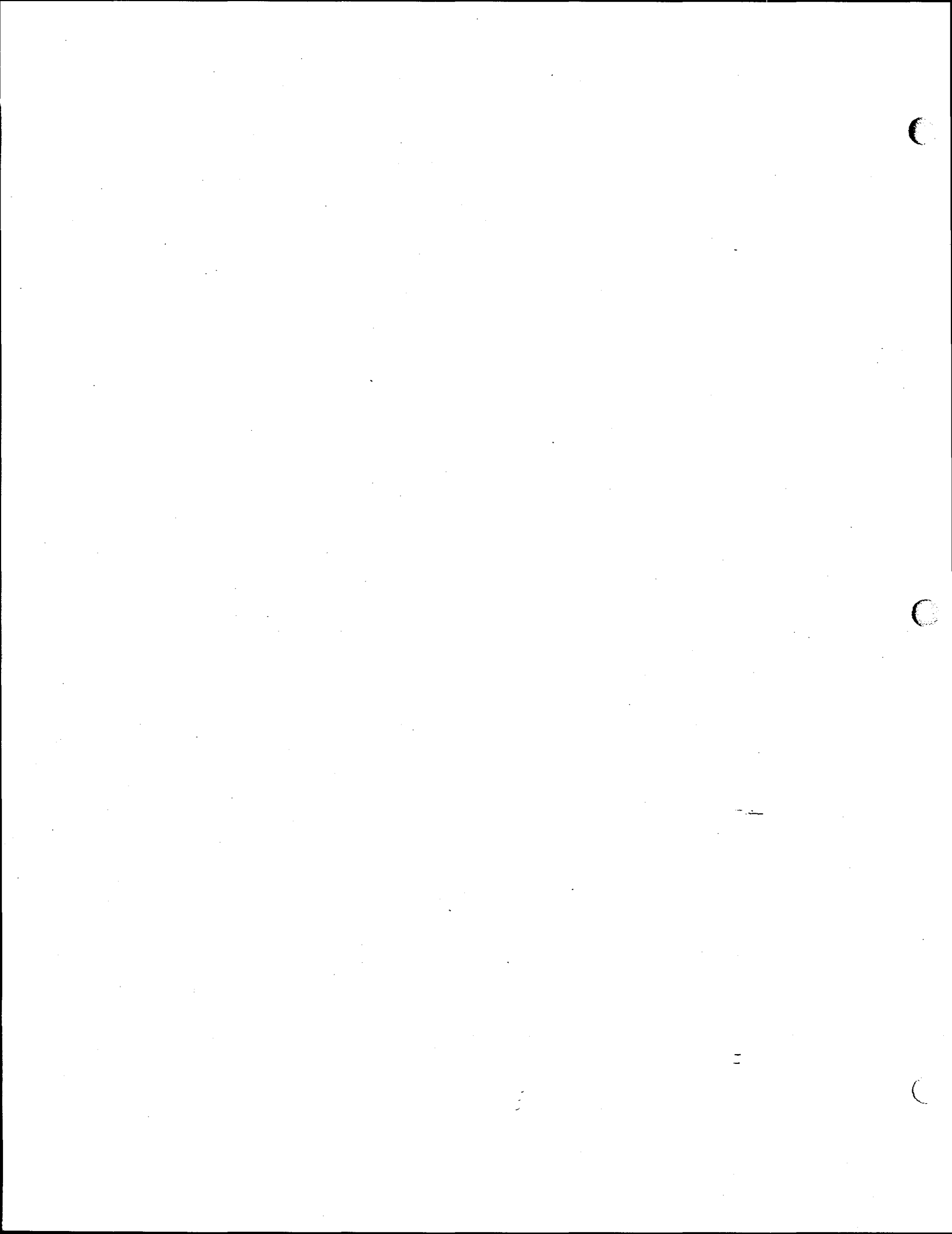

Figure 1
TNX Location Map



Figure 2

TCE Degradation Series Column Test Profile

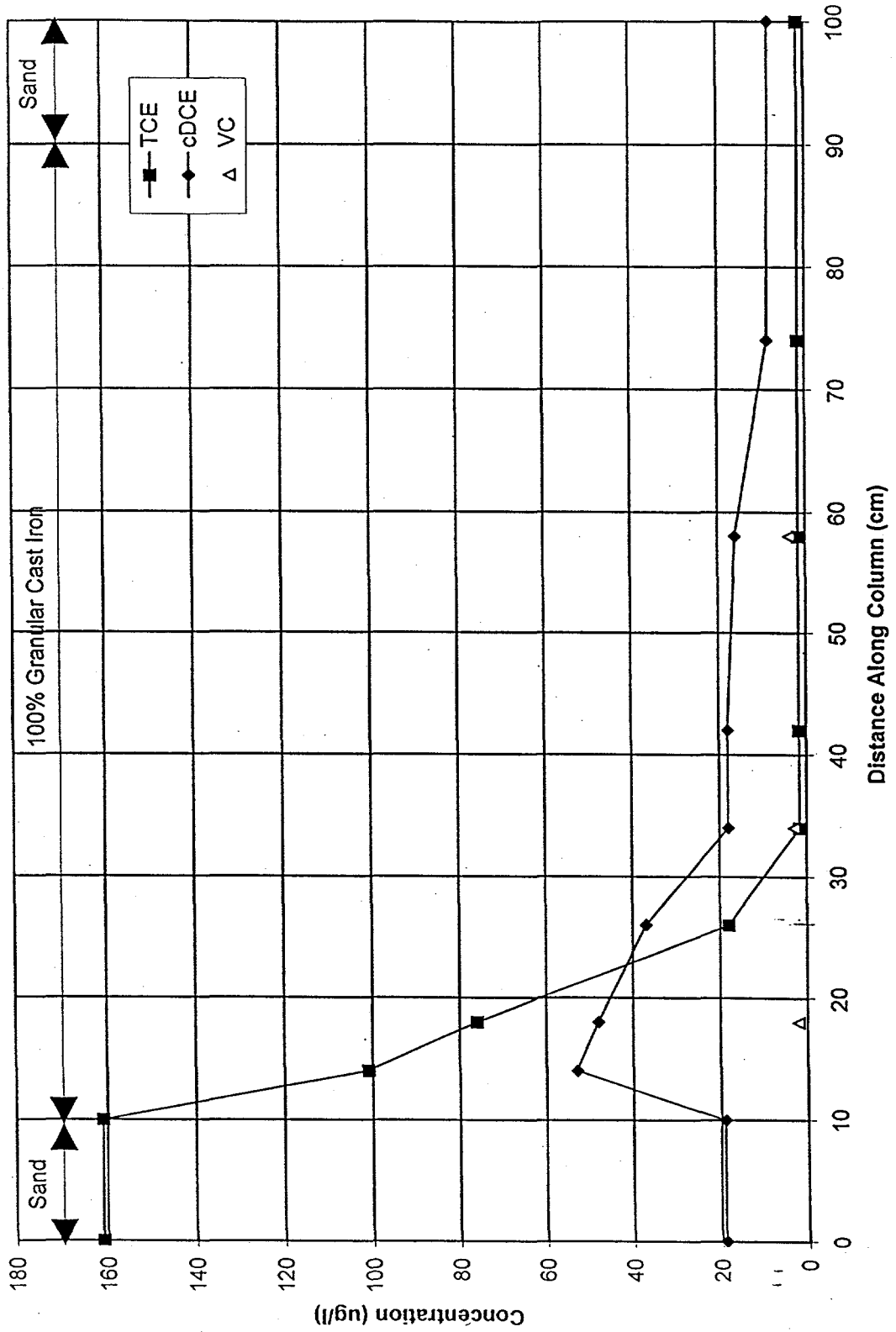

Figure 3

CT Degradation Series Column Test Profile

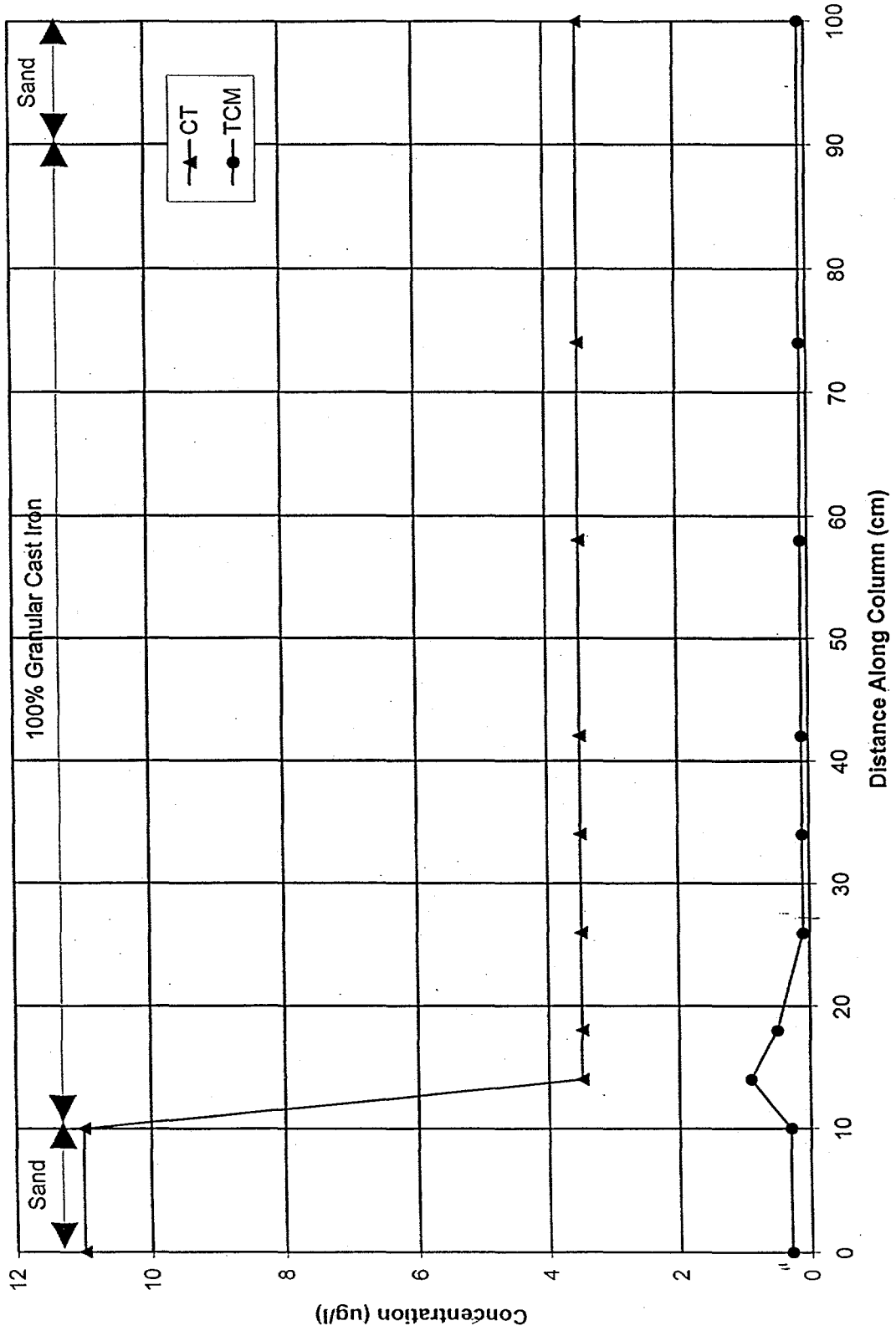

Figure 4

Eh/pH Column Test Profile

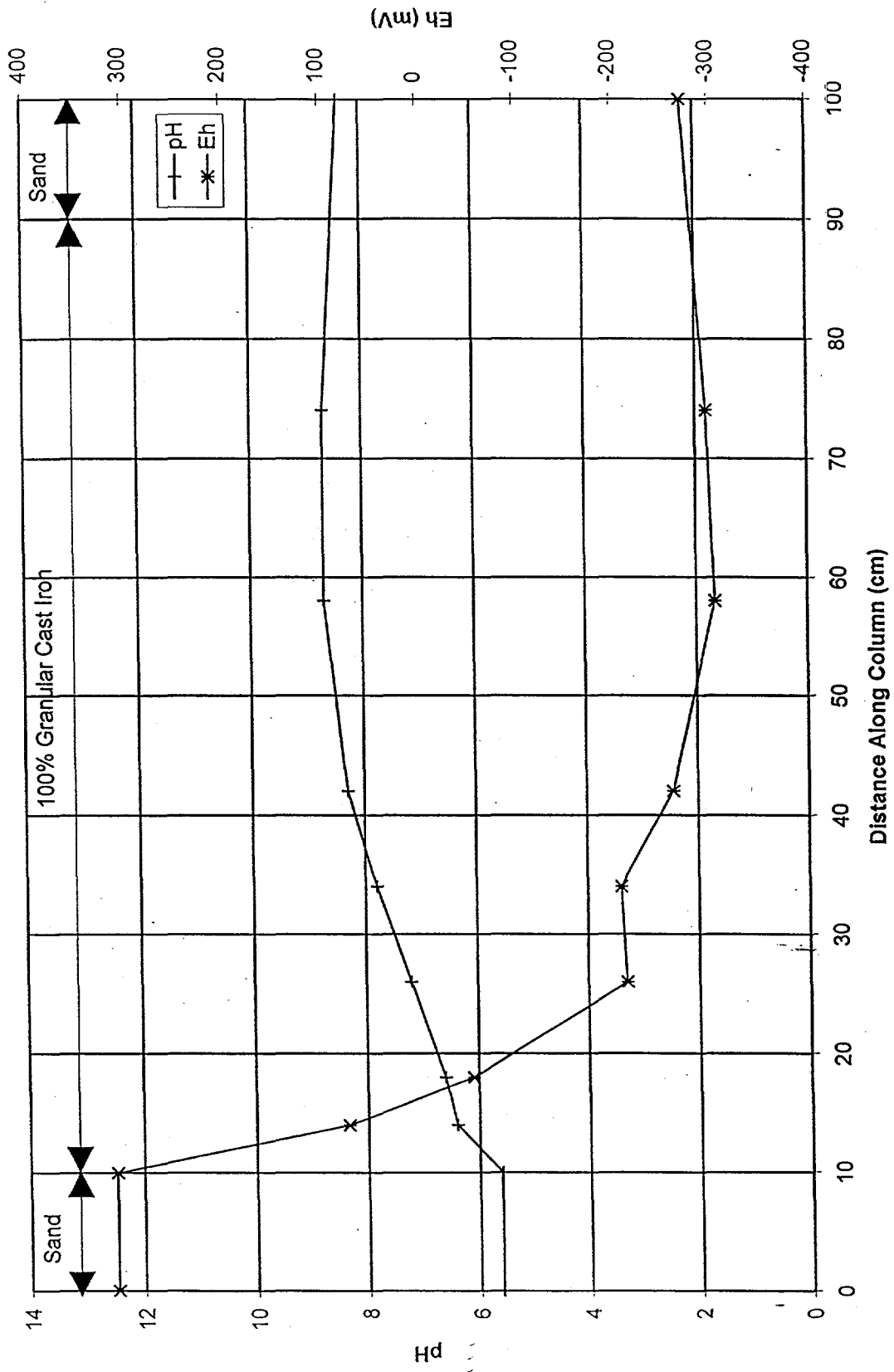

Figure 5
Generic GeoSiphon Cell

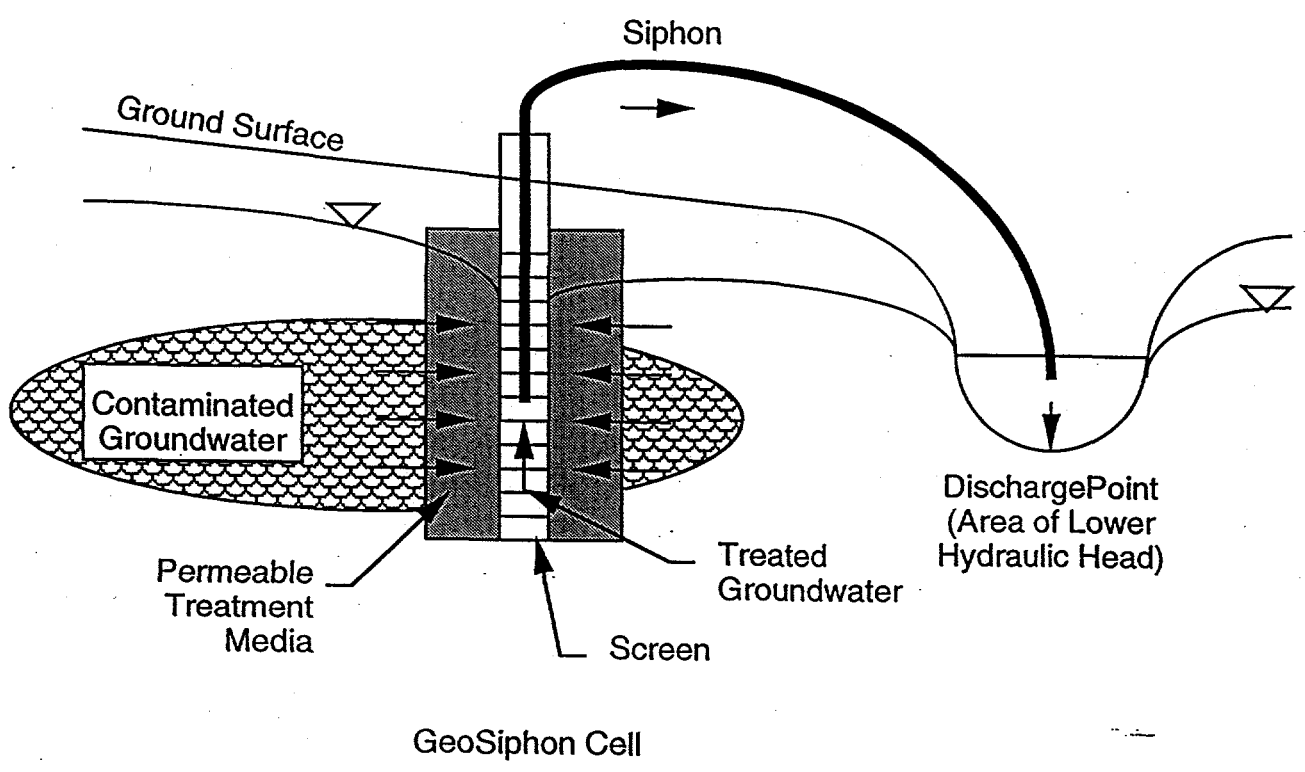

Figure 6

TNX GeoSiphon Cell (TGSC-1) Location Map

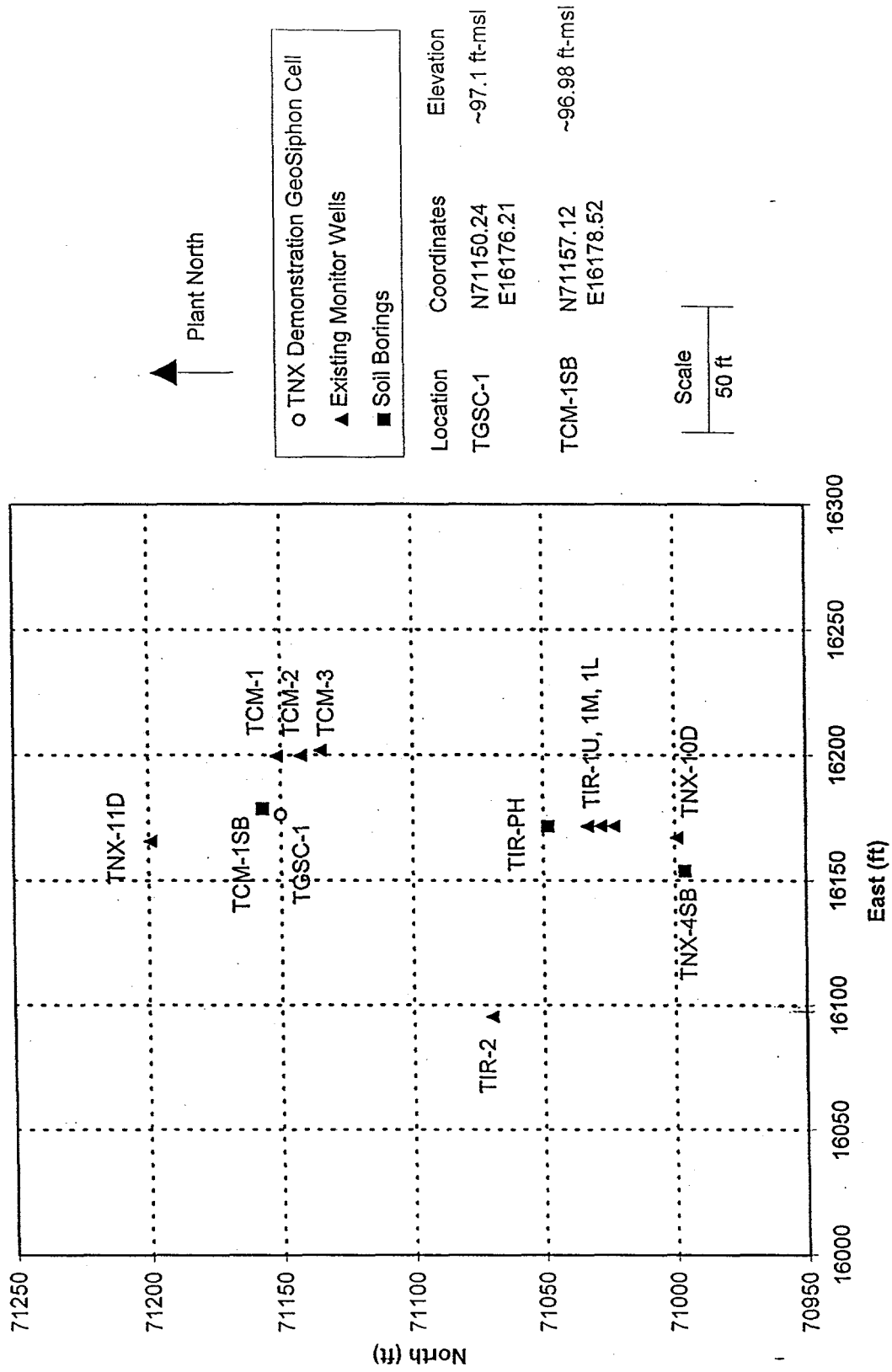

Figure 7

Soil Boring TCM-1SB and Screen Locations

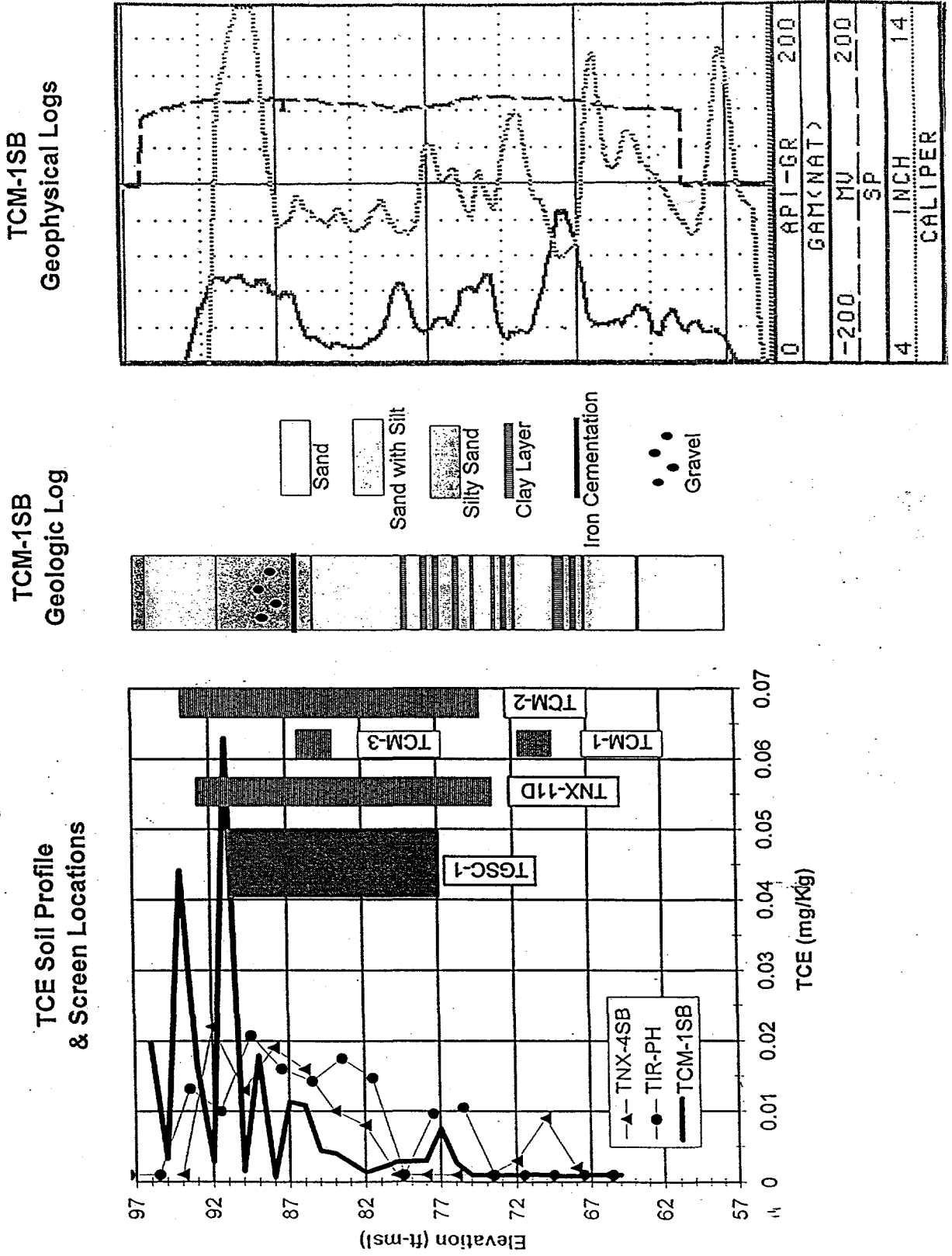

Figure 8
TNX GeoSiphon Cell (TGSC-1)

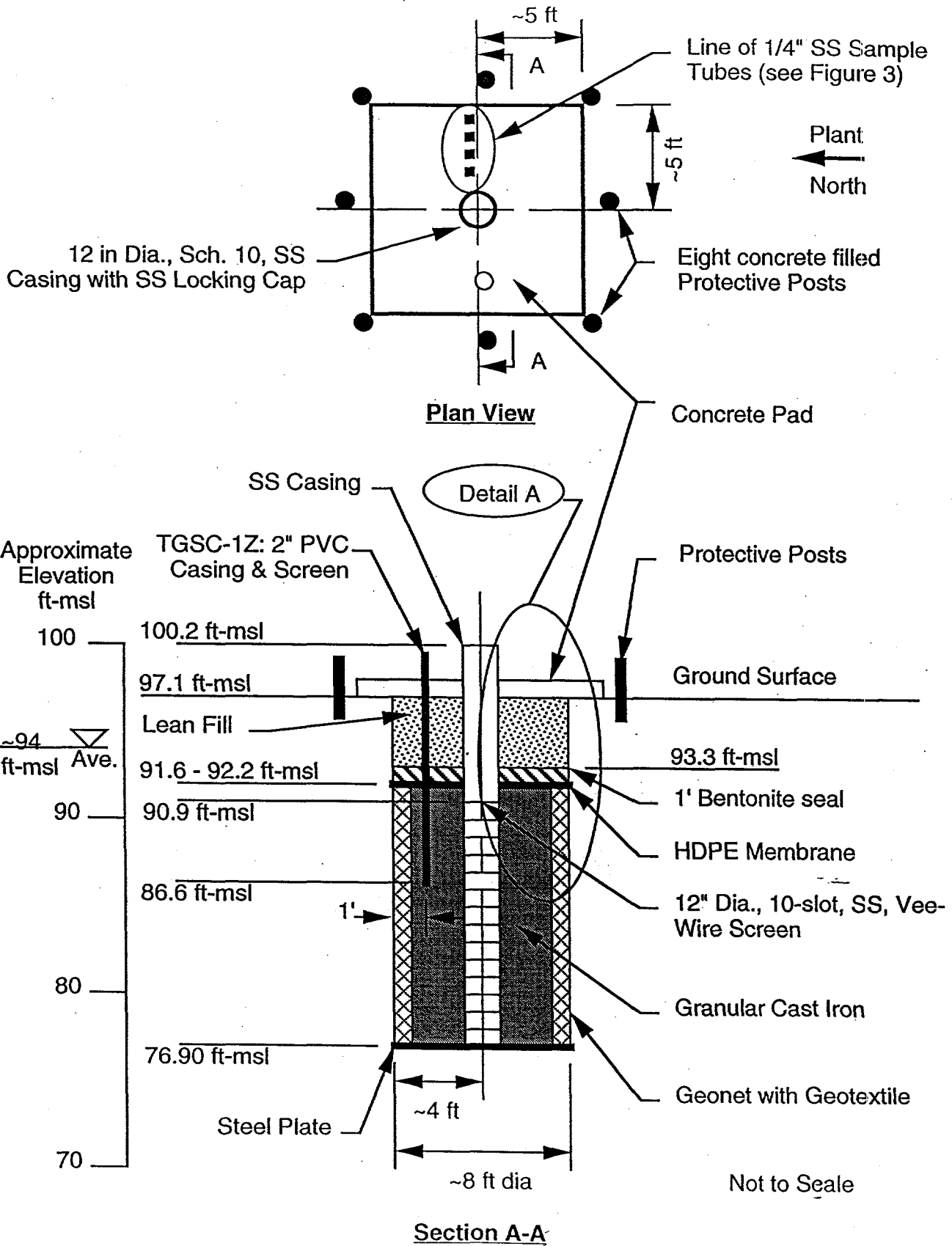
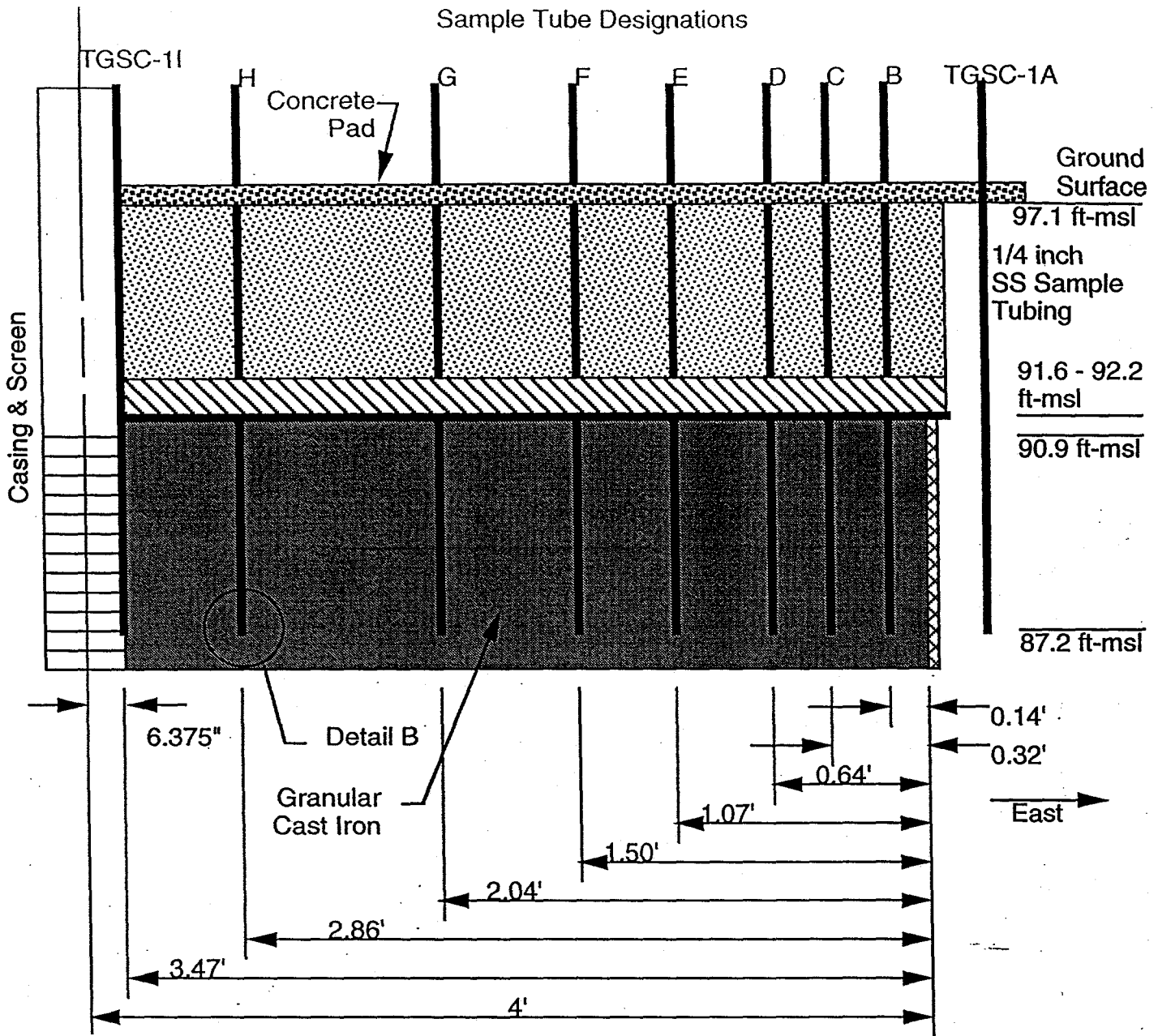

Figure 9
 TNX GeoSiphon Cell
 SS Sample Tube Locations & Designations



Not to Scale
Detail A
 TNX GeoSiphon SS Sample Tube Locations

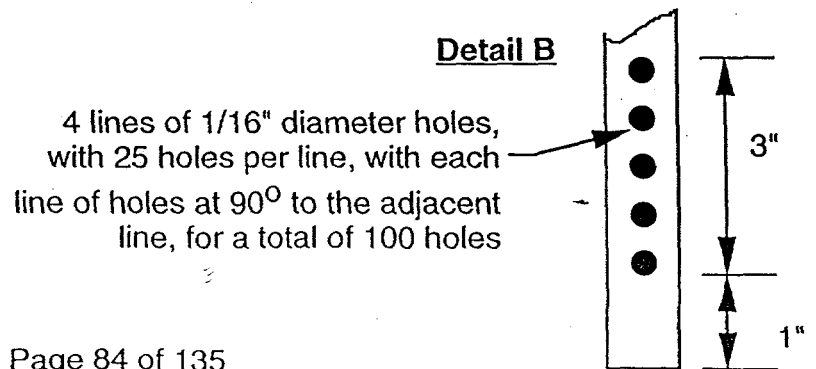

Figure 10
 GeoSiphon Cell Well Head Details
 (Phase I Testing)

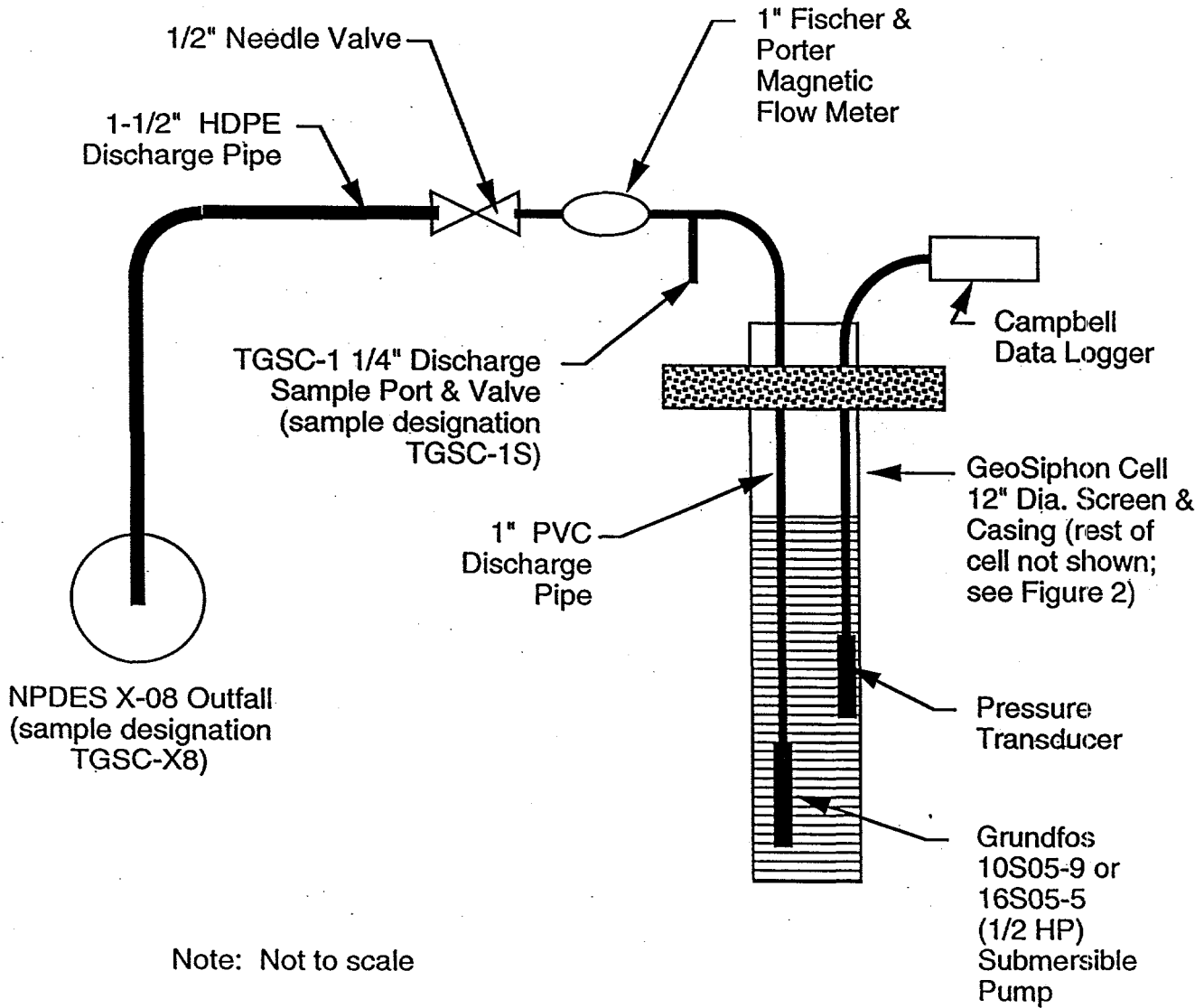

Figure 11

TCE Degradation Series
TGSC-1 Profile at 0.97 gpm (9/30/97 Steady State Data)

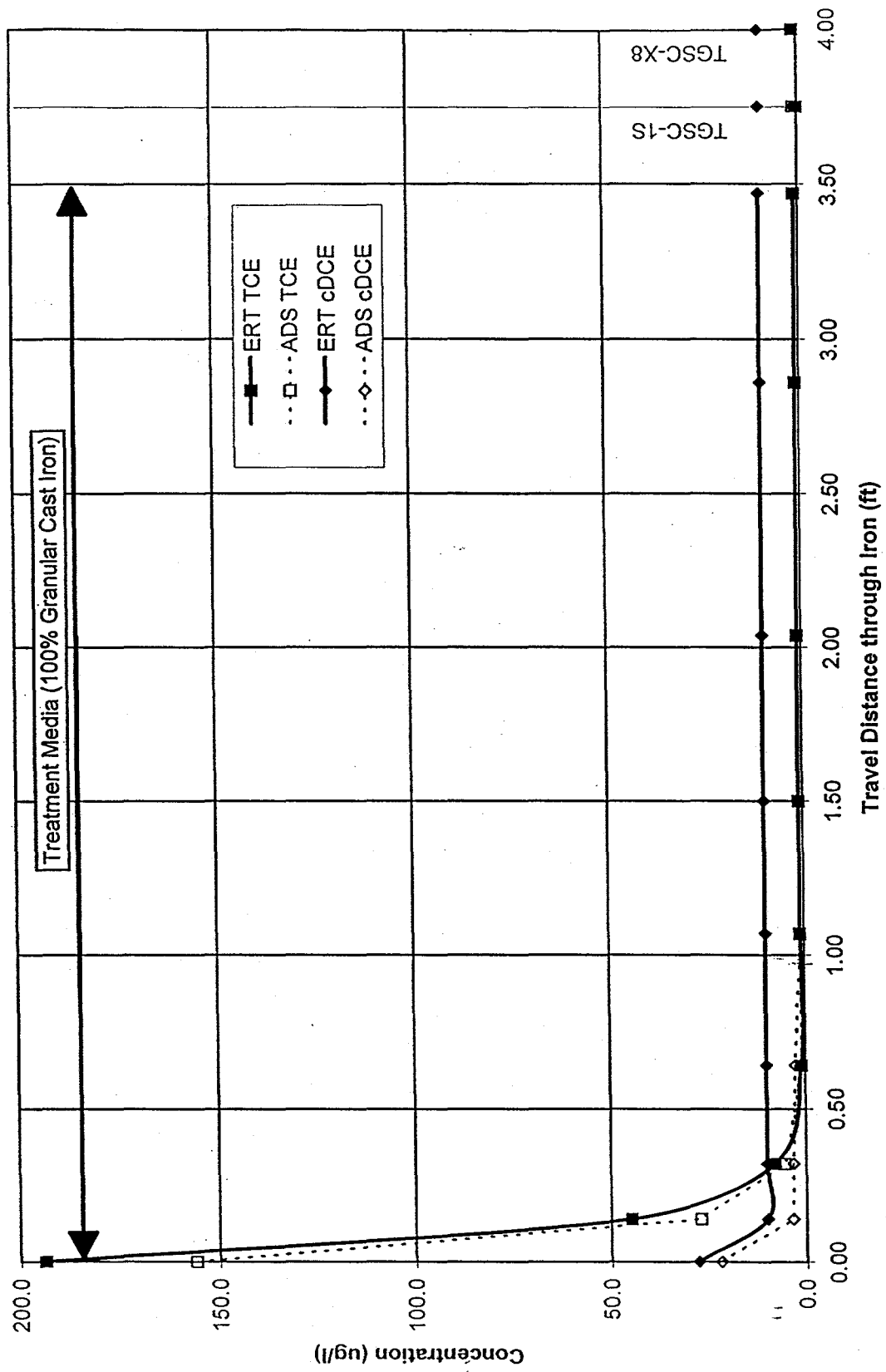

Figure 12

CT Degradation Series
TGSC-1 Profile at 0.97 gpm (9/30/97 Steady State Data)

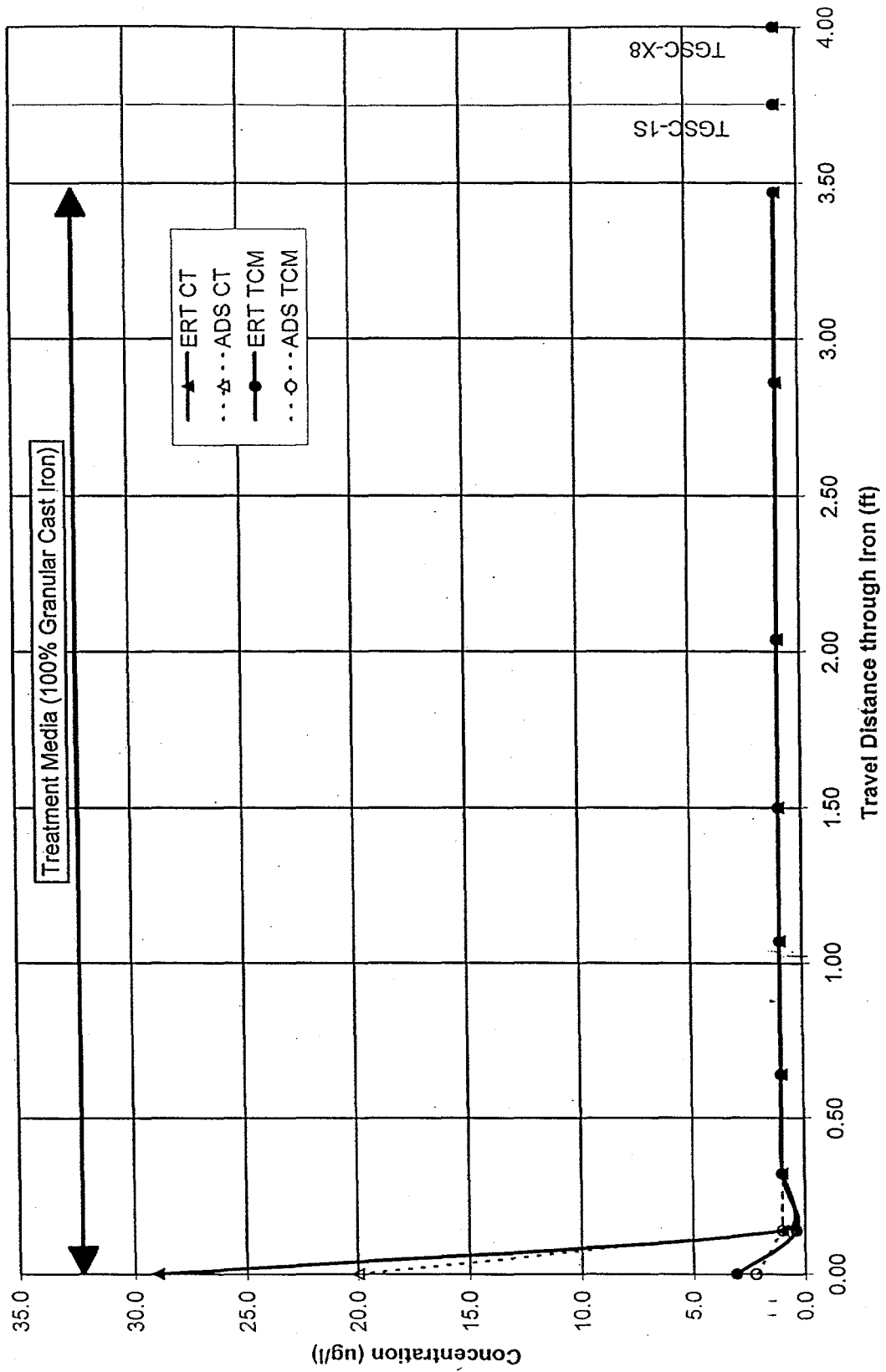

Figure 13

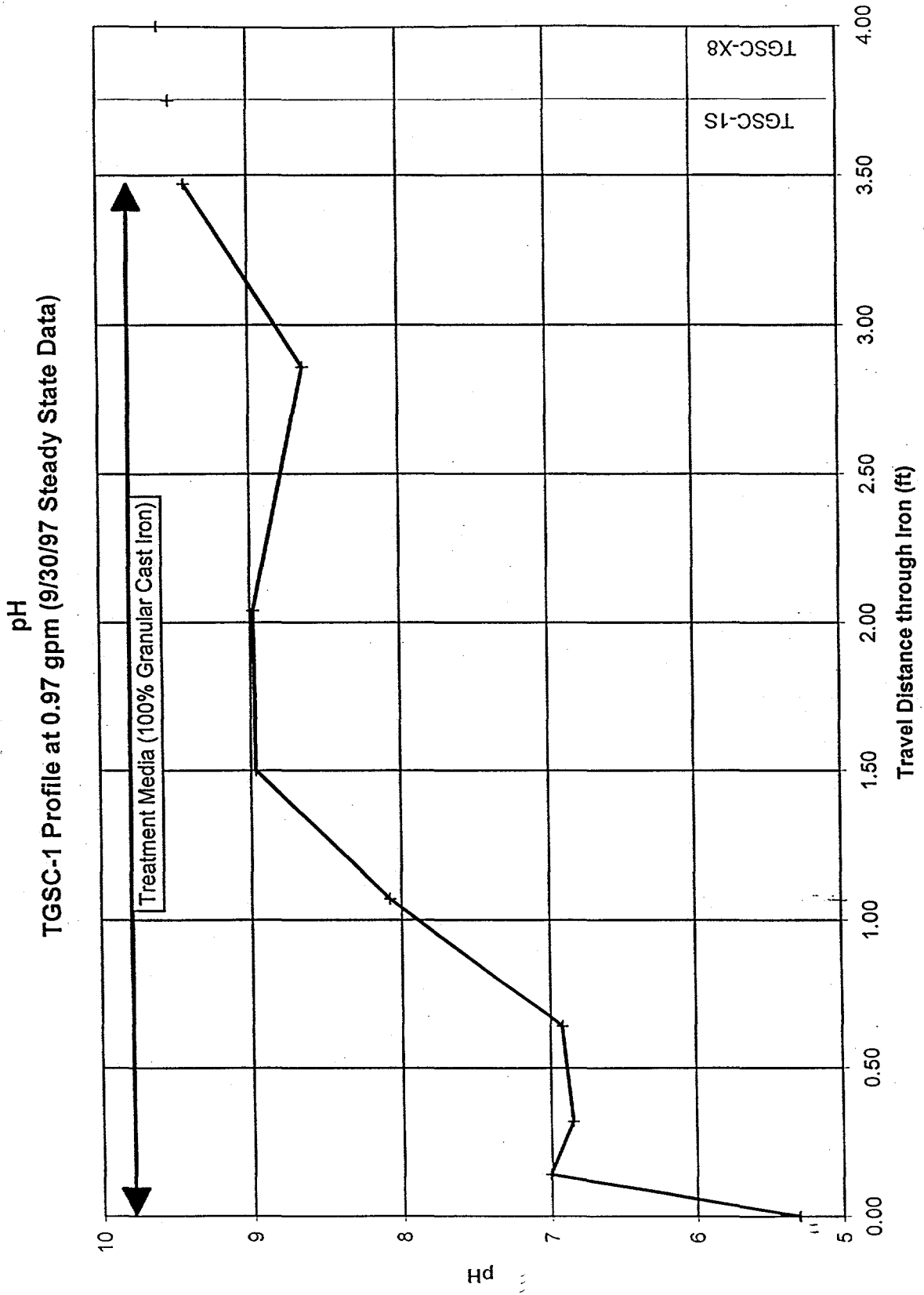

Figure 14

TCE Degradation Series
TGSC-1 Profile at 4.00 gpm (11/11/97 Steady State Data)

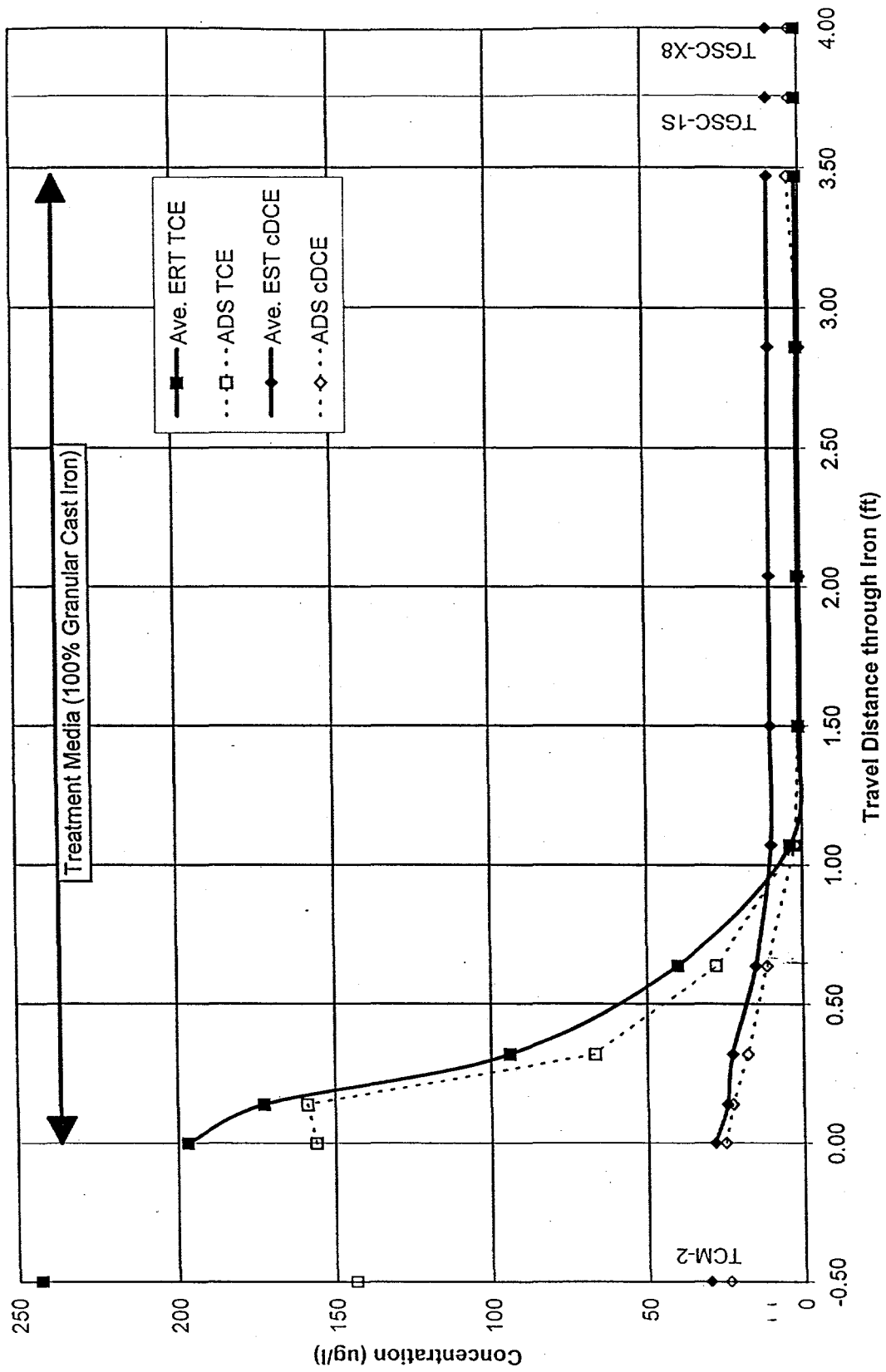

Figure 15

CT Degradation Series
TGSC-1 Profile at 4.00 gpm (1/11/97 Steady State Data)

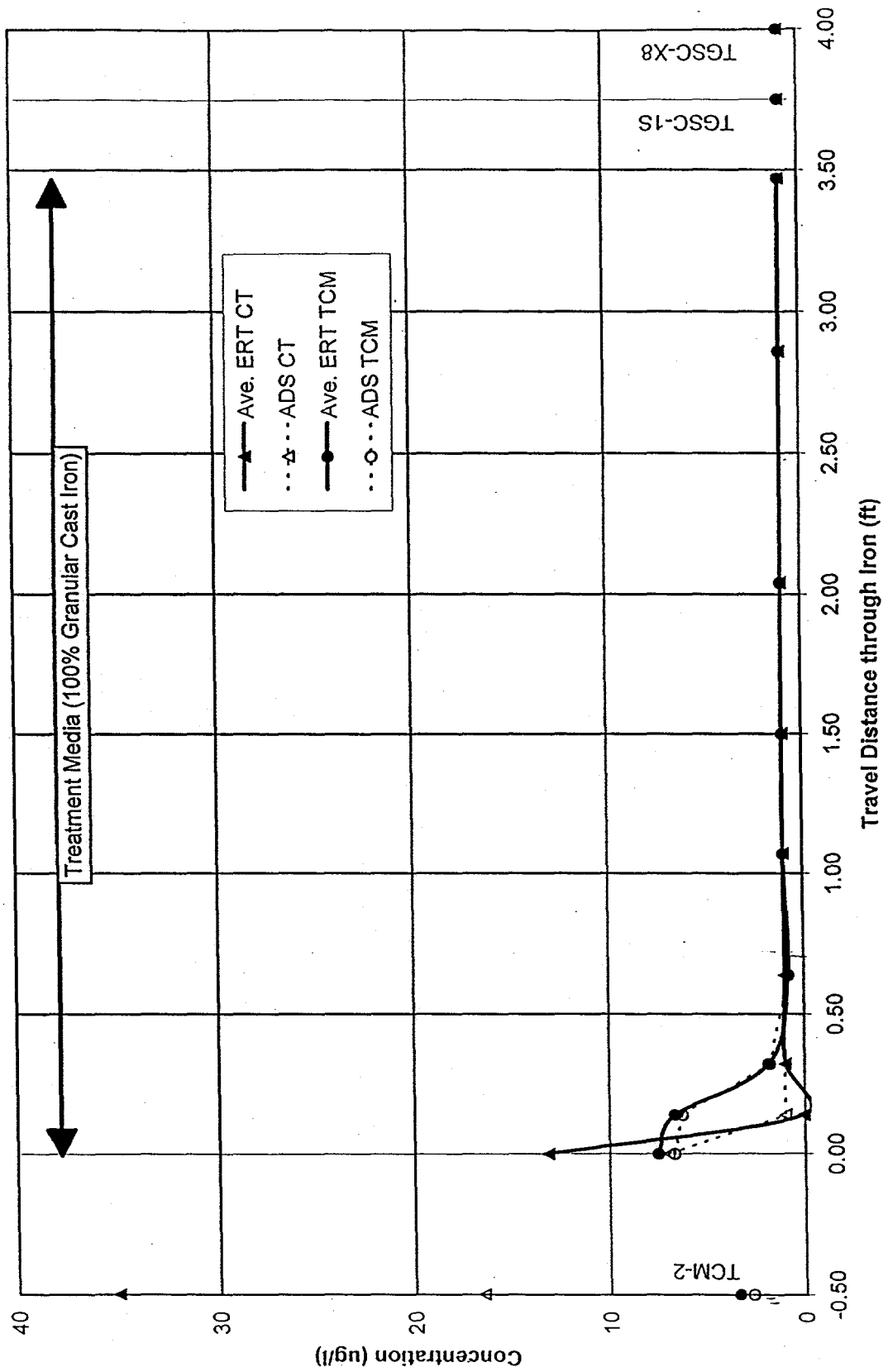

Figure 16

TGSC-1 Profile at 4.00 gpm (11/11/97 Steady State Data)

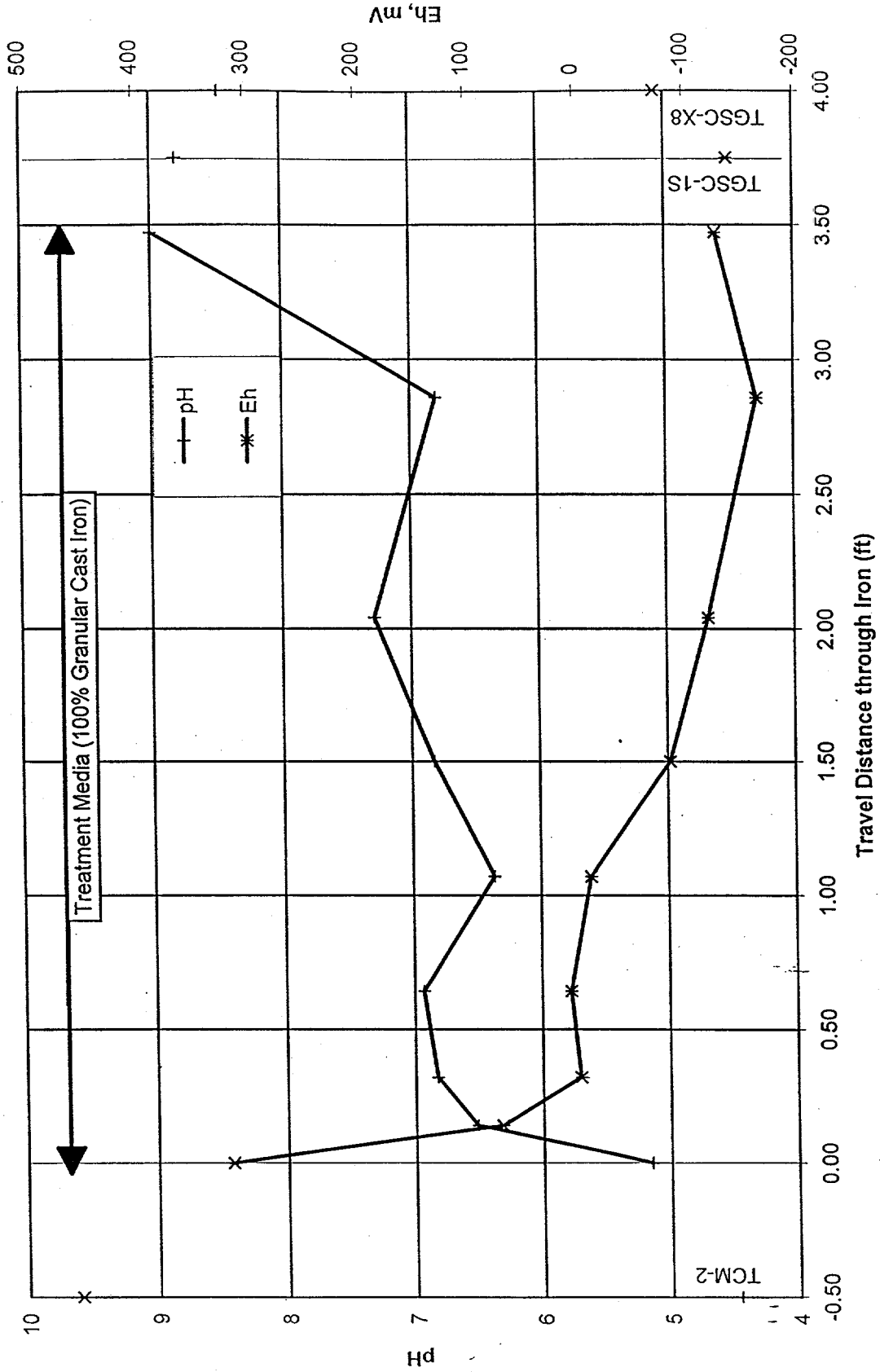

Figure 17

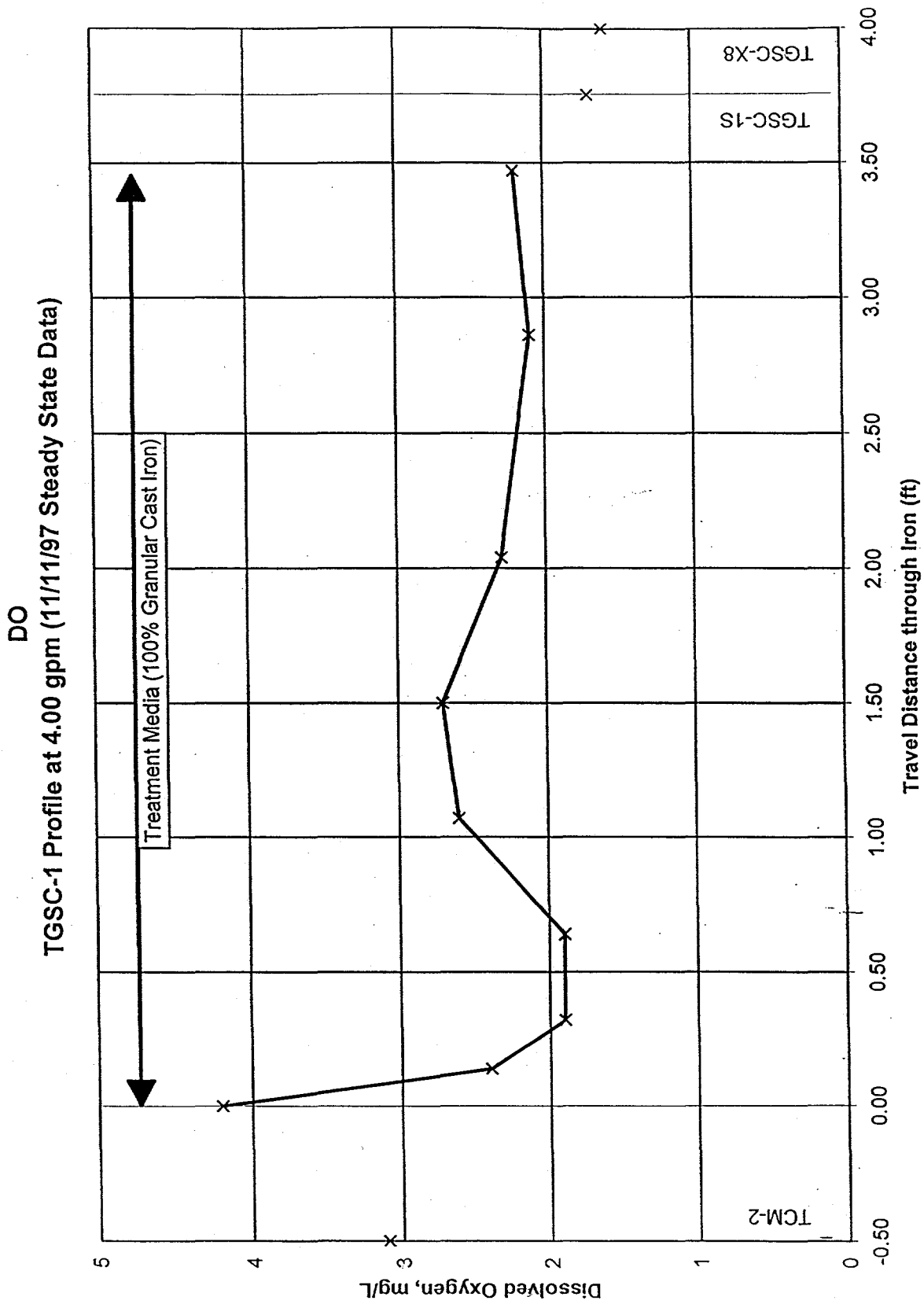

Figure 18

TCE Degradation Series
TGSC-1 Profile at 7.98 gpm (12/16/97 Steady State Data)

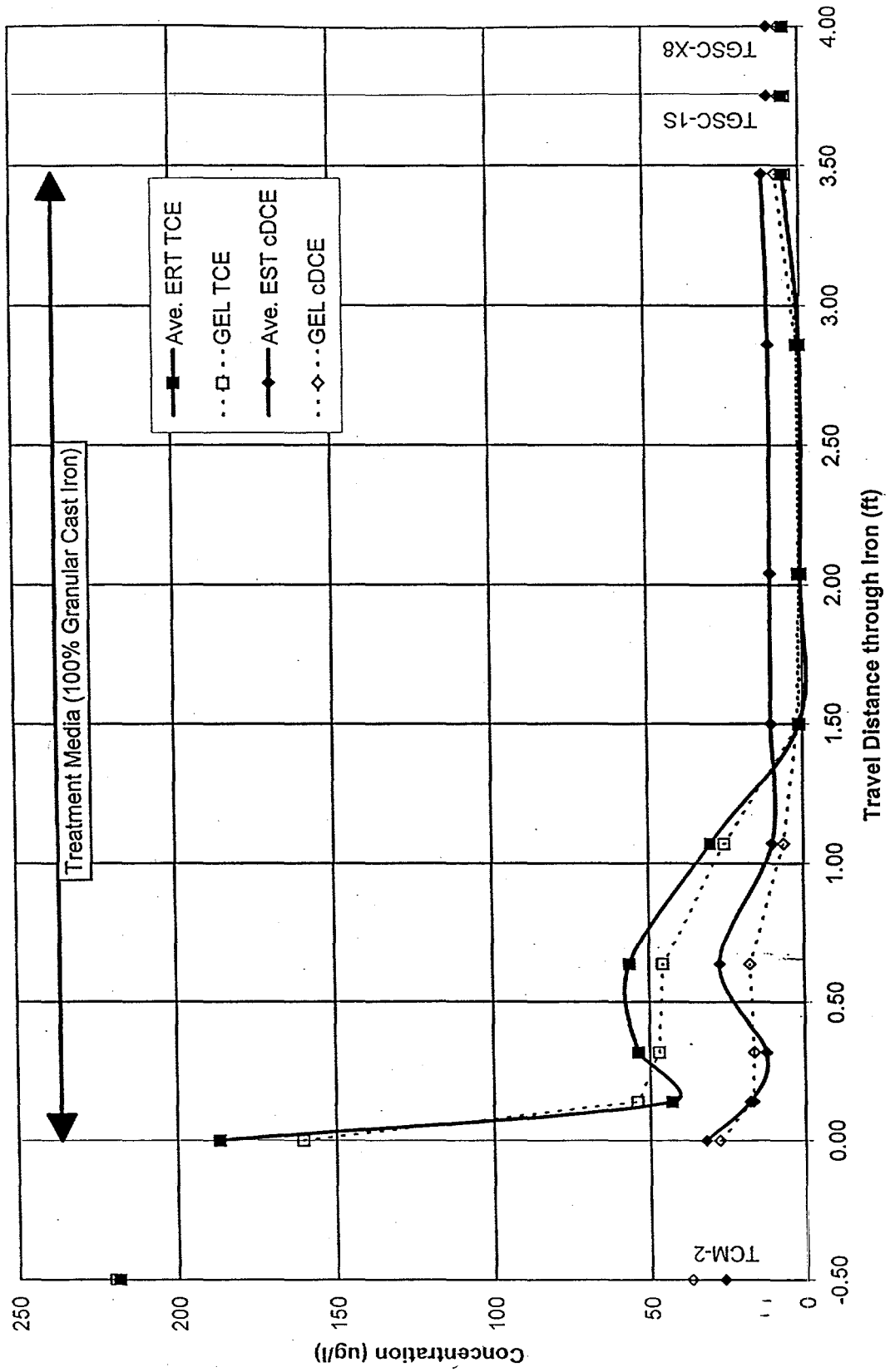

Figure 19

CT Degradation Series
TGSC-1 Profile at 7.98 gpm (12/16/97 Steady State Data)

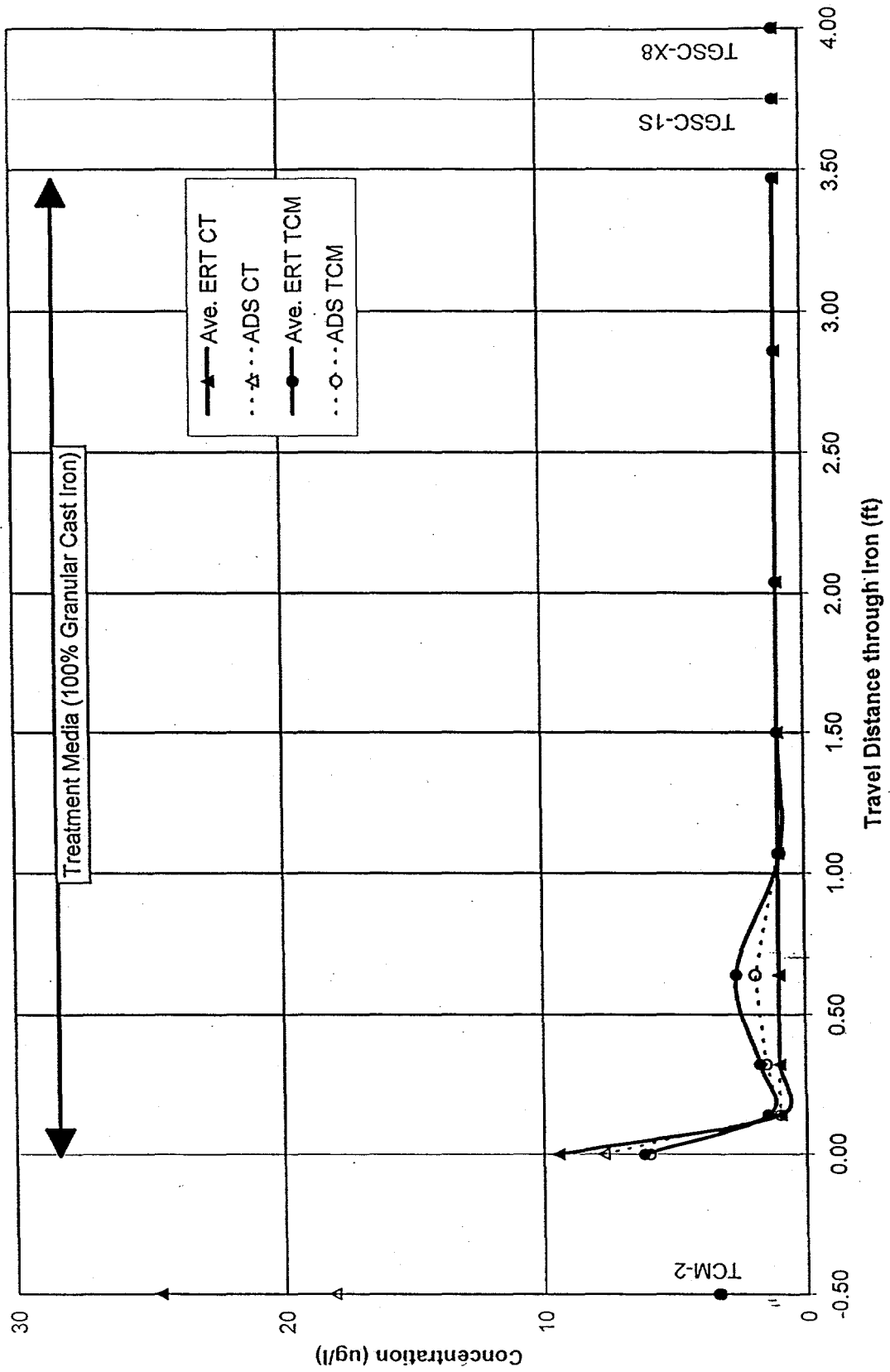

Figure 20

TGSC-1 Profile at 7.98 gpm (12/16/97 Steady State Data)

pH / Eh

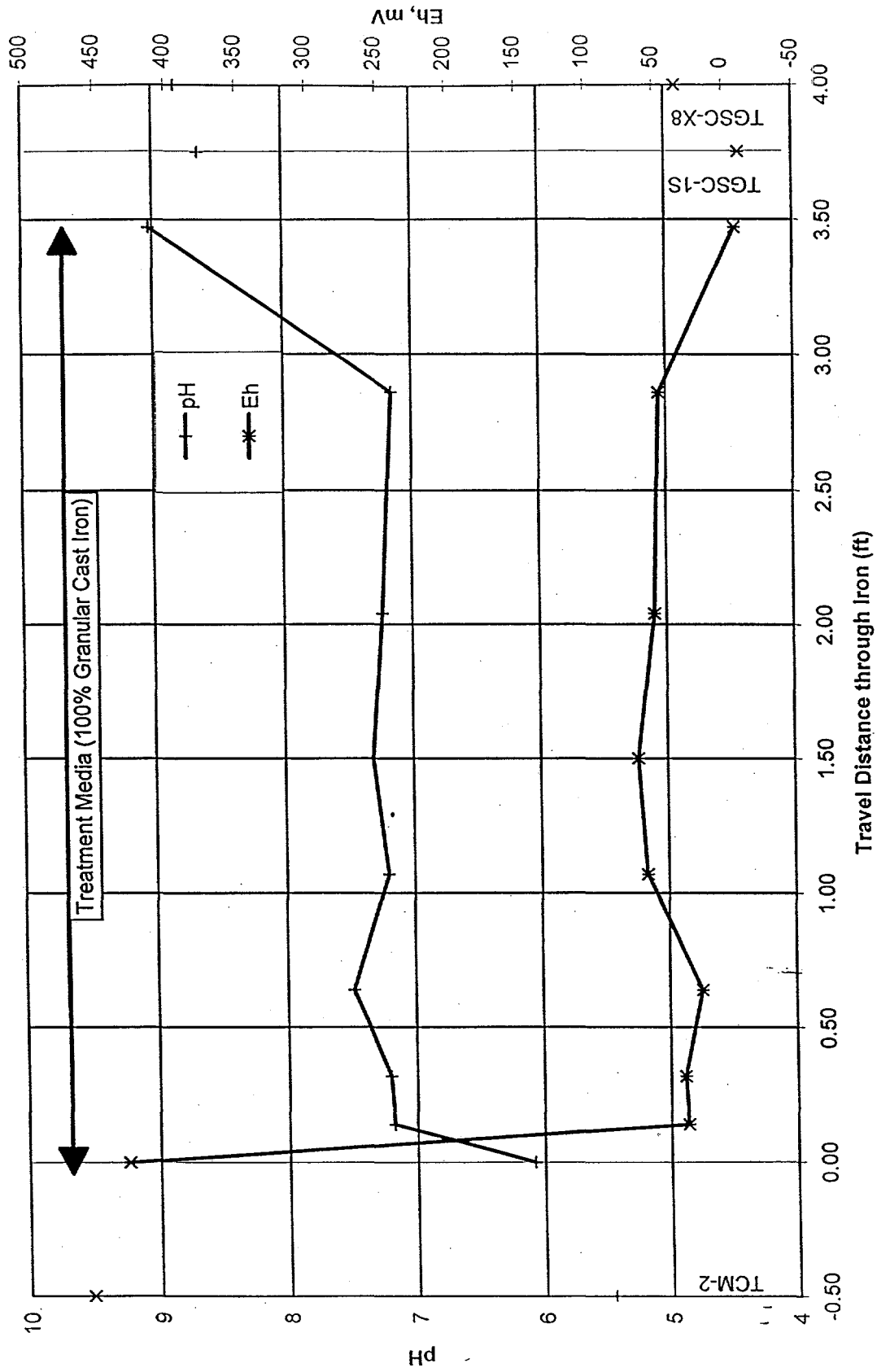

Figure 21

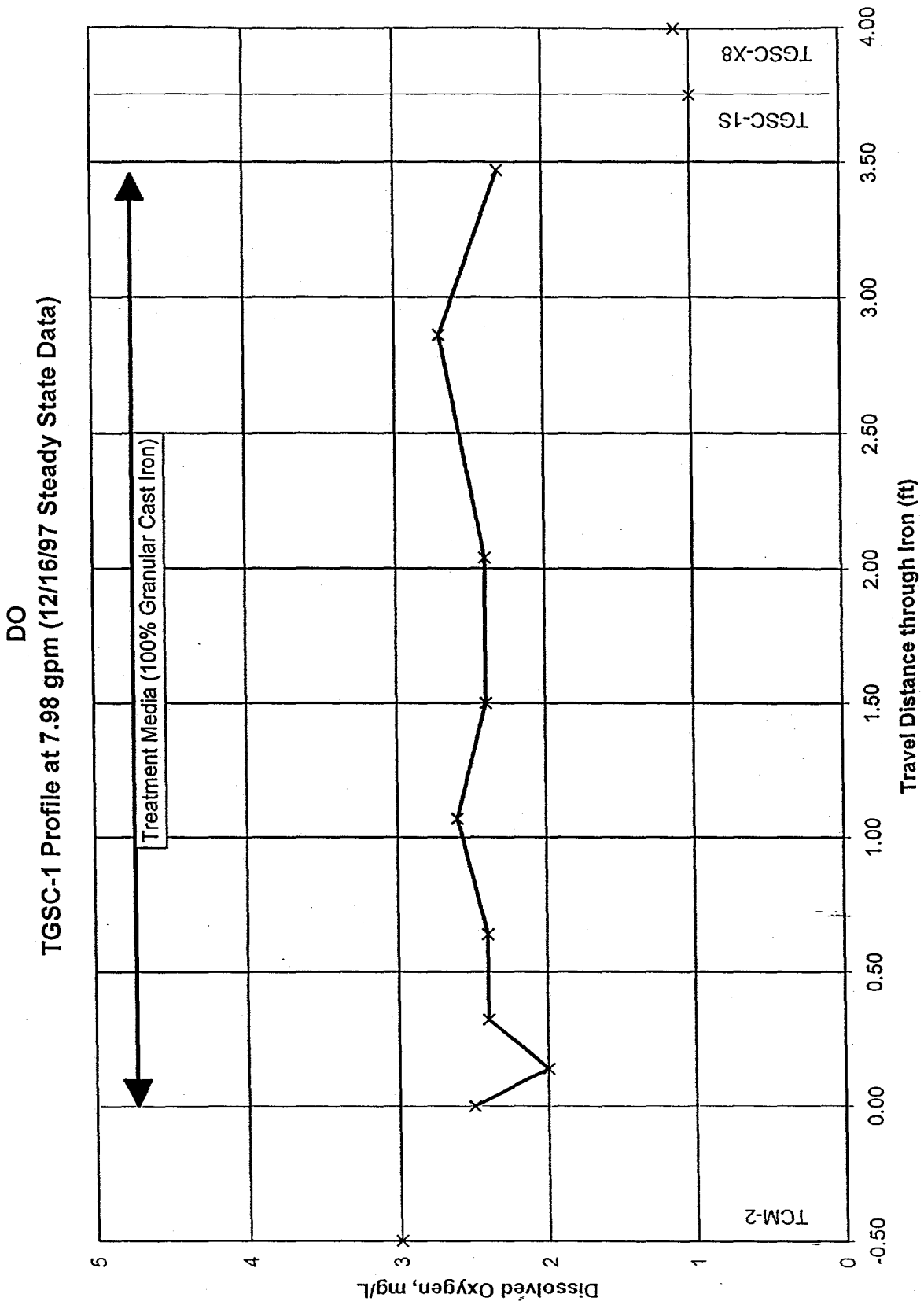

Figure 22

TCE Degradation Series
TGSC-1 Profile at 7.68 gpm (12/2/97 Data)

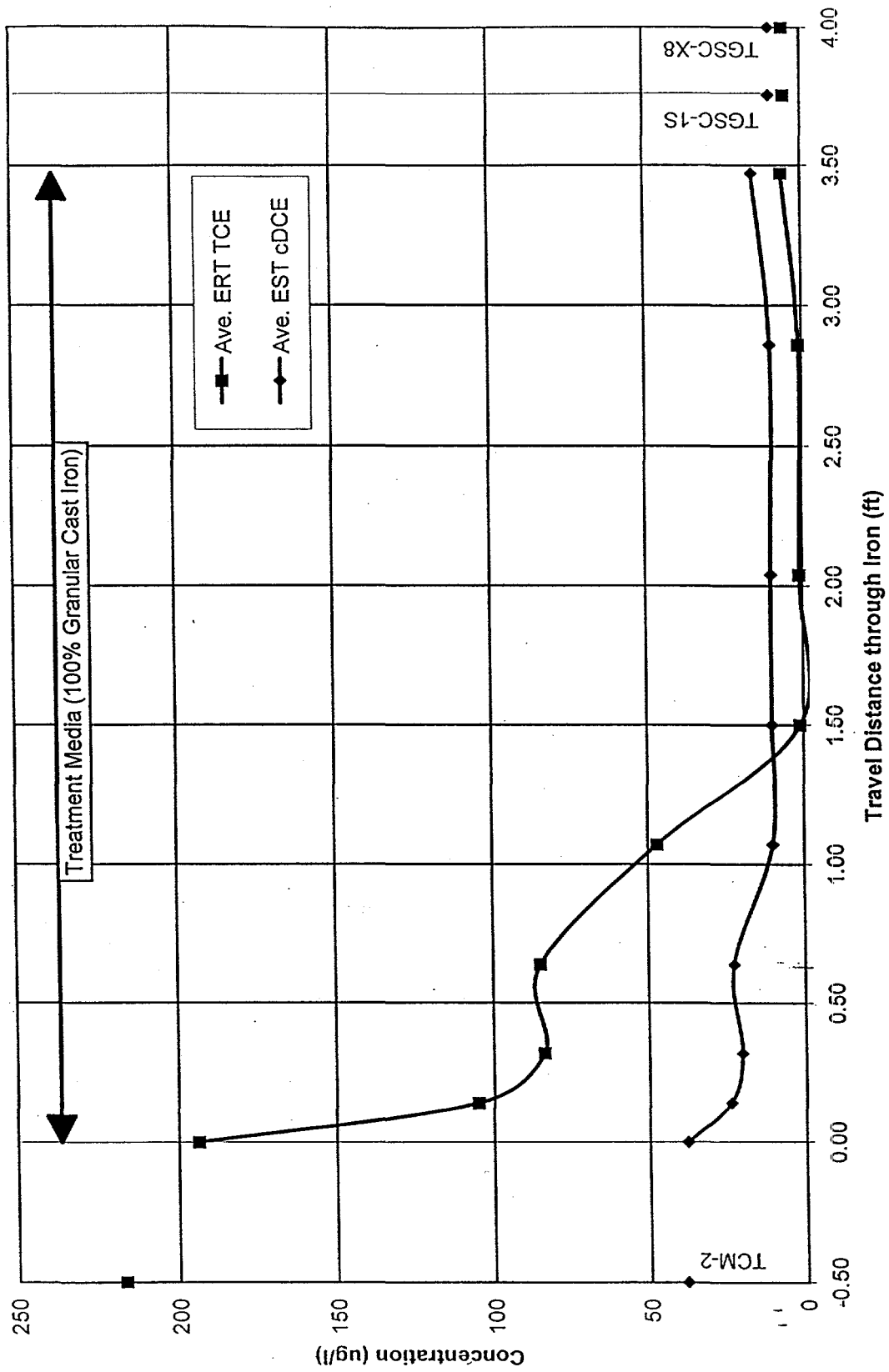

Figure 23

CT Degradation Series
TGSC-1 Profile at 7.68 gpm (12/2/97 Data)

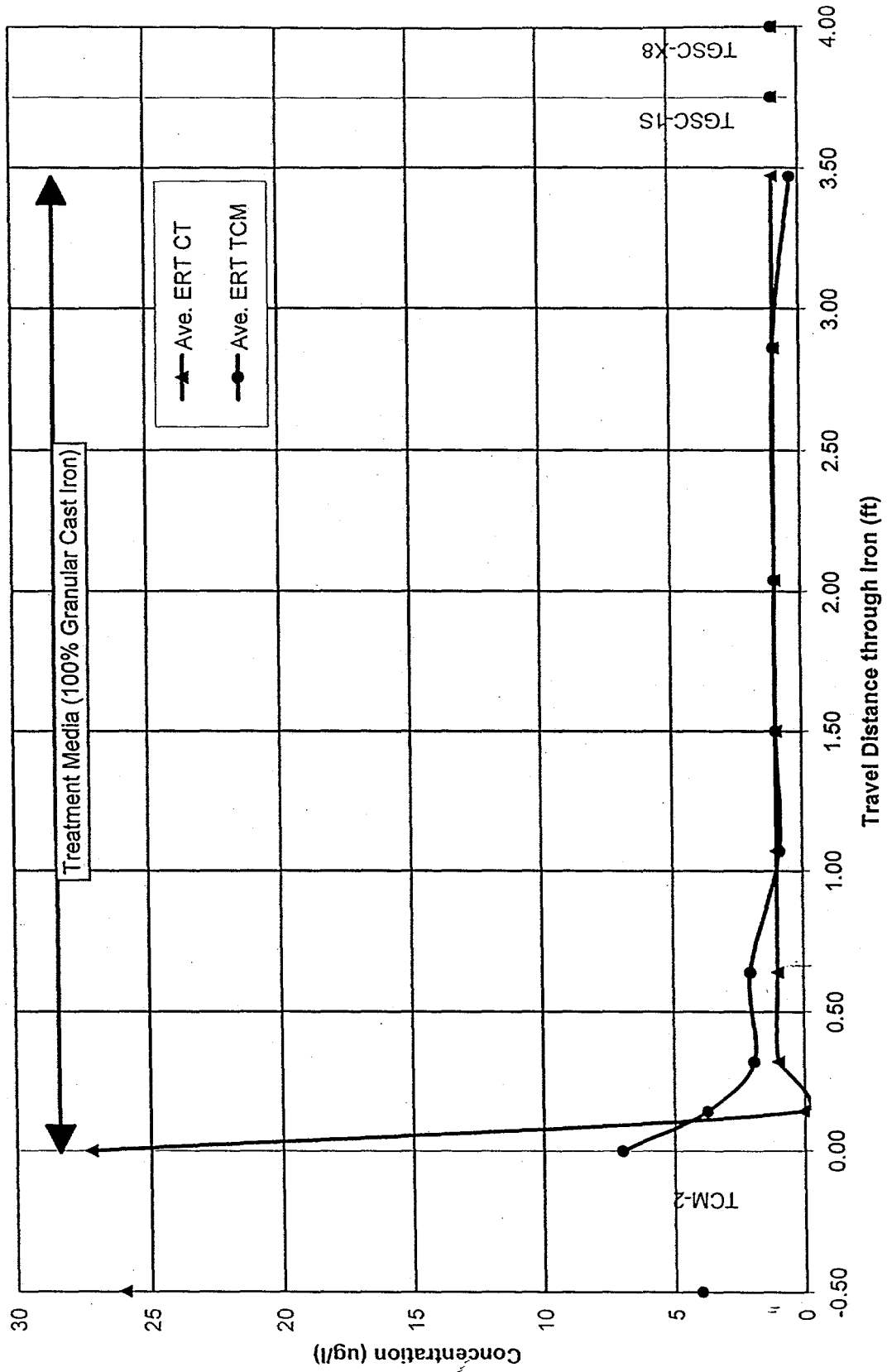

Figure 24

pH / Eh
TGSC-1 Profile at 7.68 gpm (12/2/97 Data)

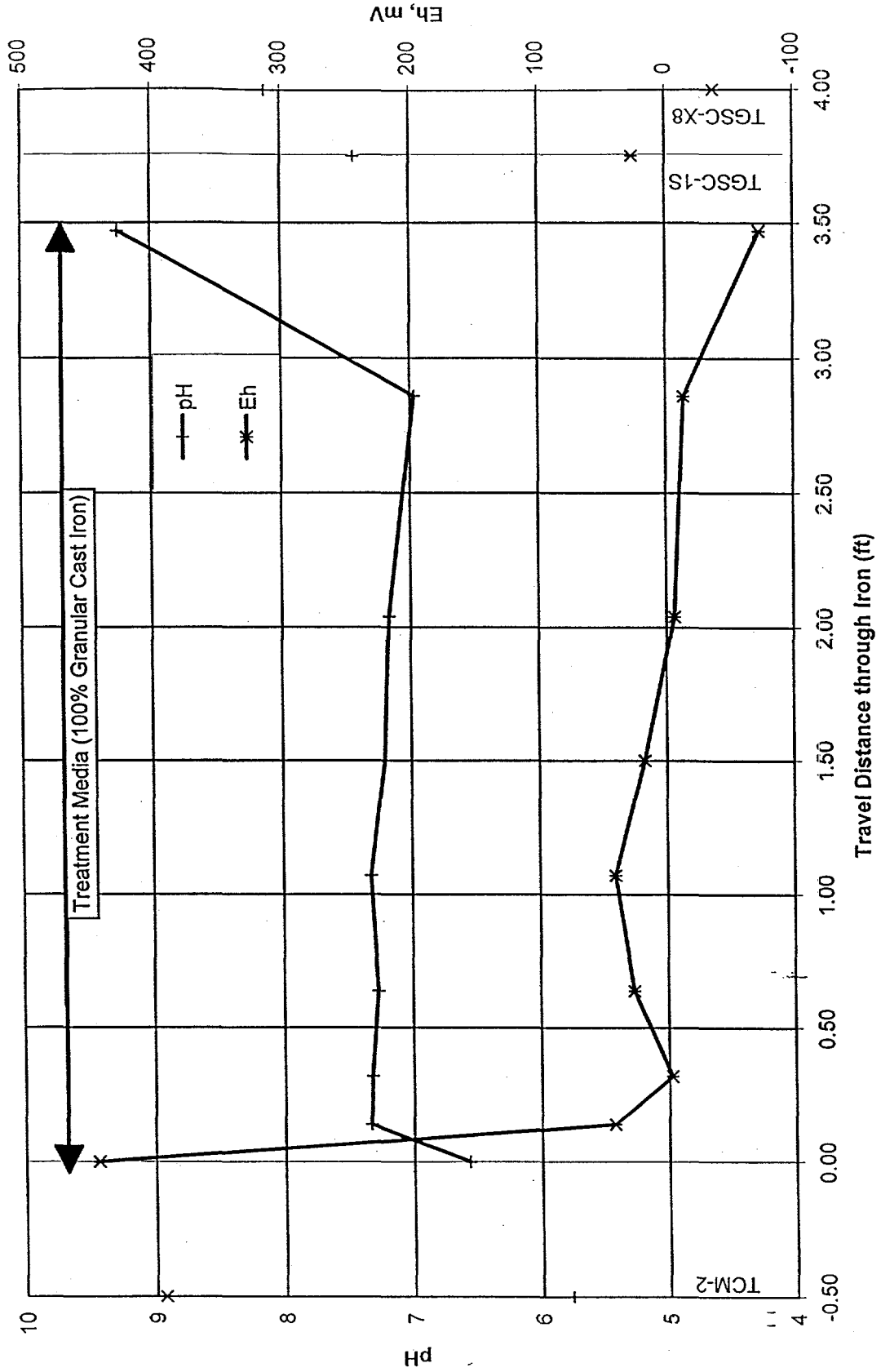

Figure 25

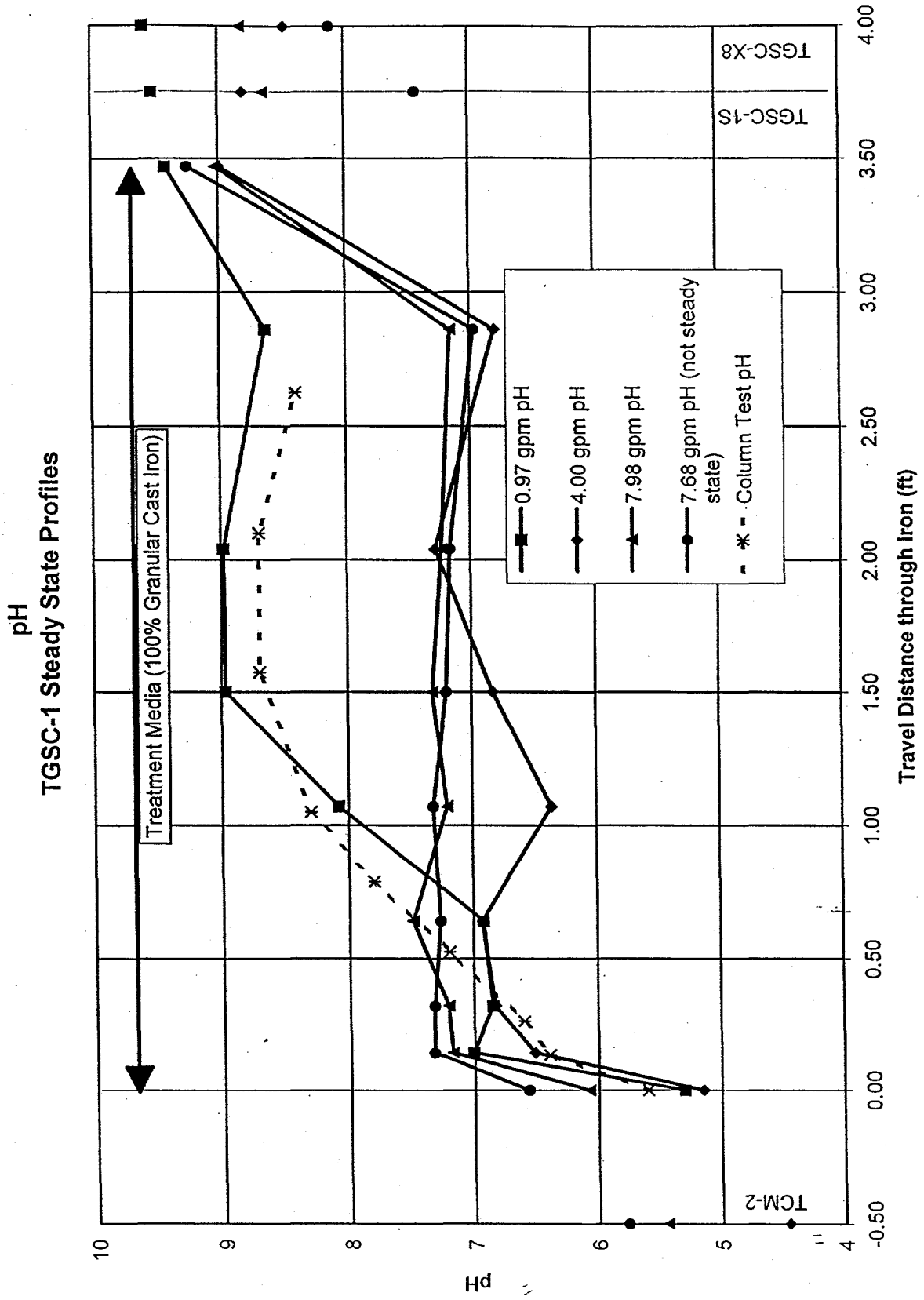

Figure 26

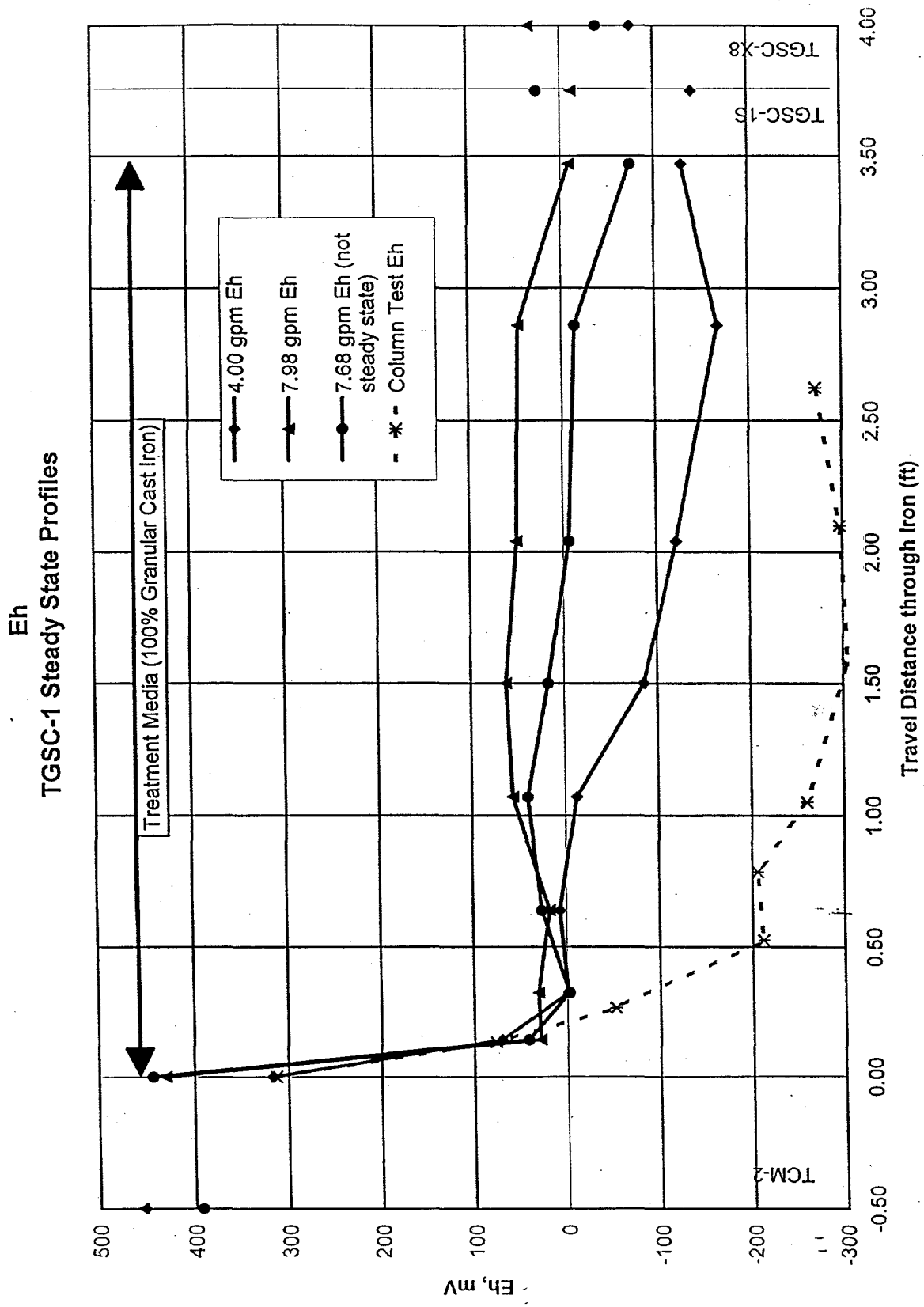

Figure 27

TCE Degradation TGSC-1 Steady State Profiles

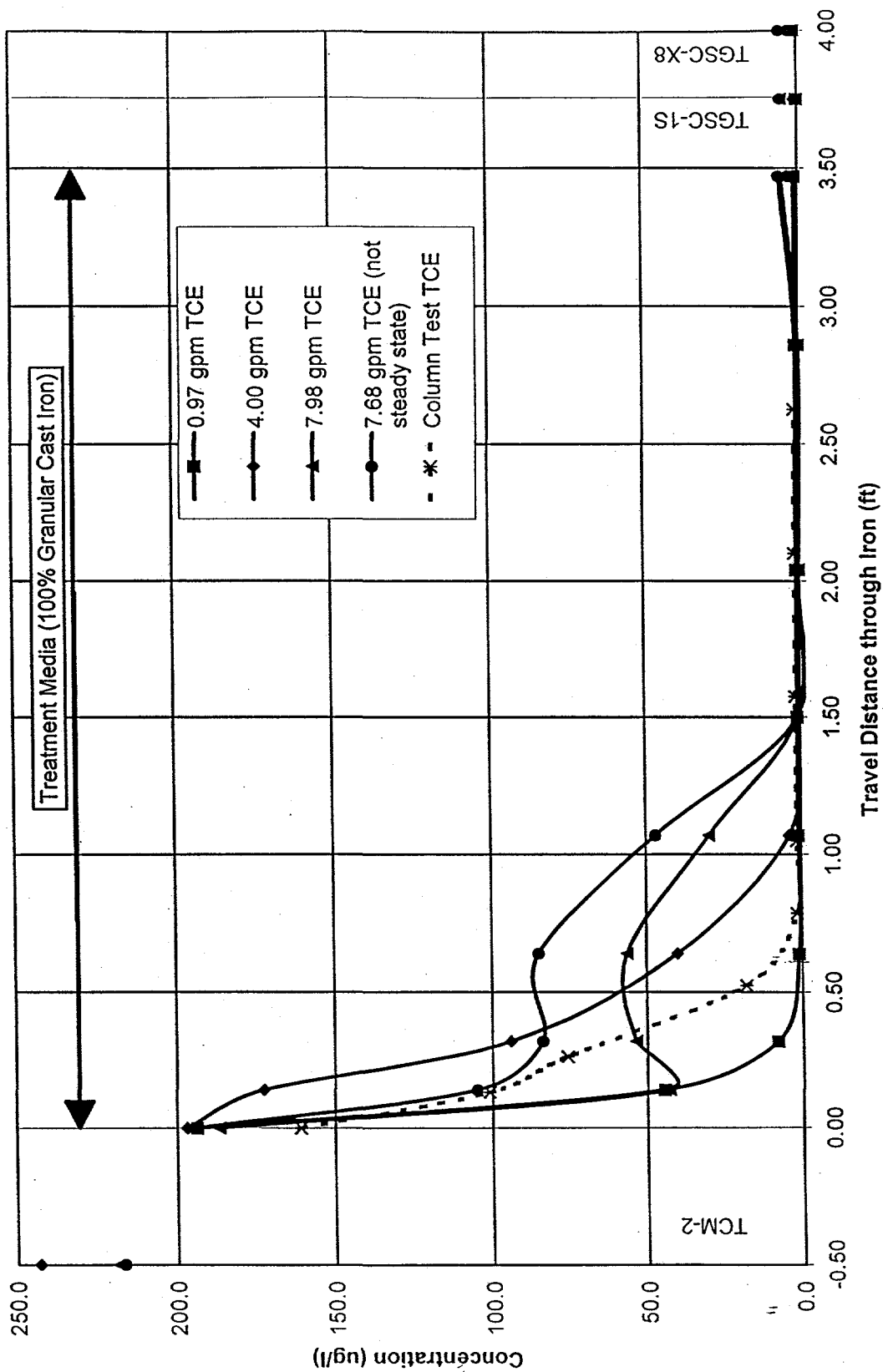

Figure 28

cDCE Degradation
TGSC-1 Steady State Profiles

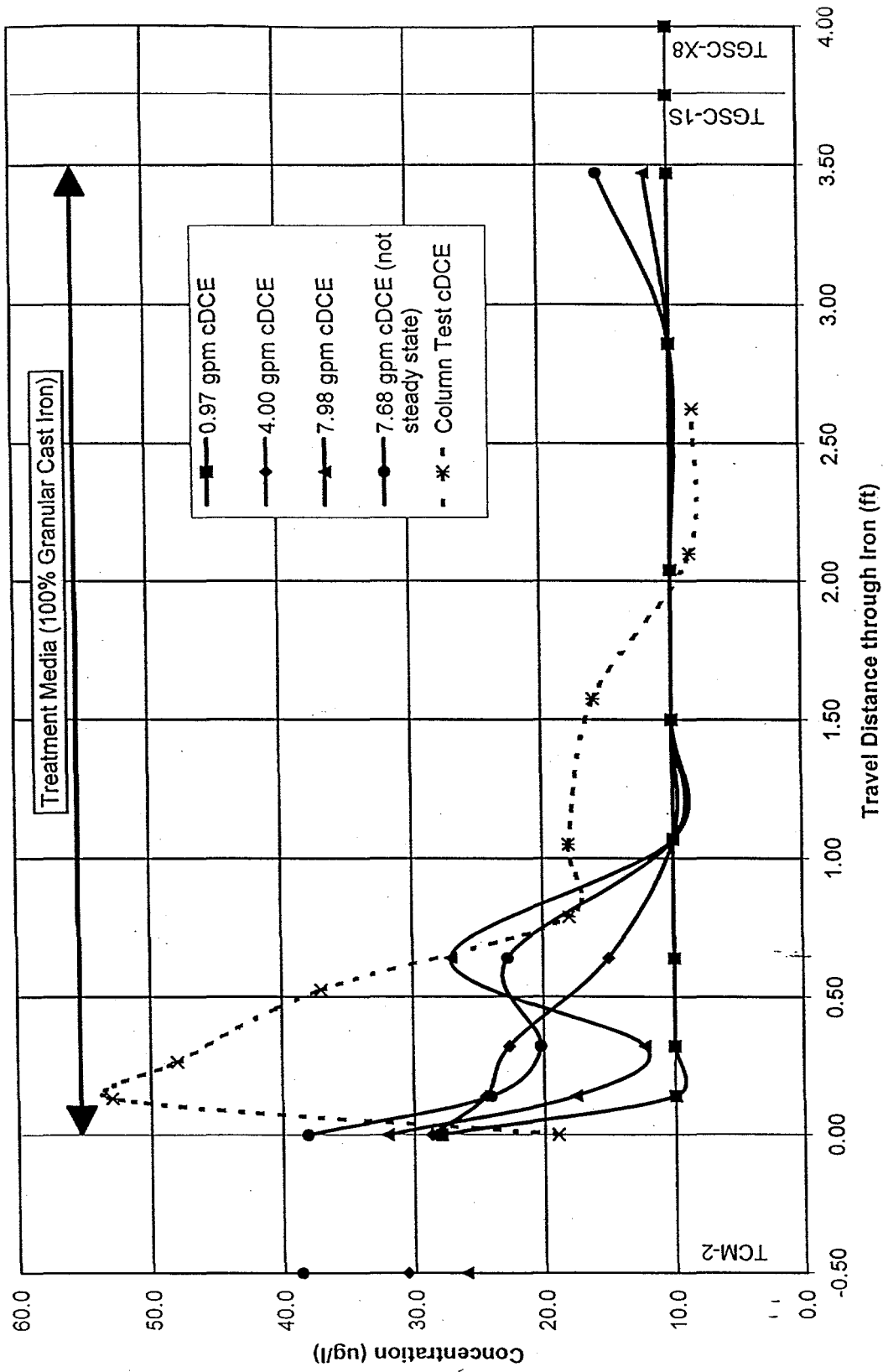

Figure 29

CT Degradation TGSC-1 Steady State Profiles

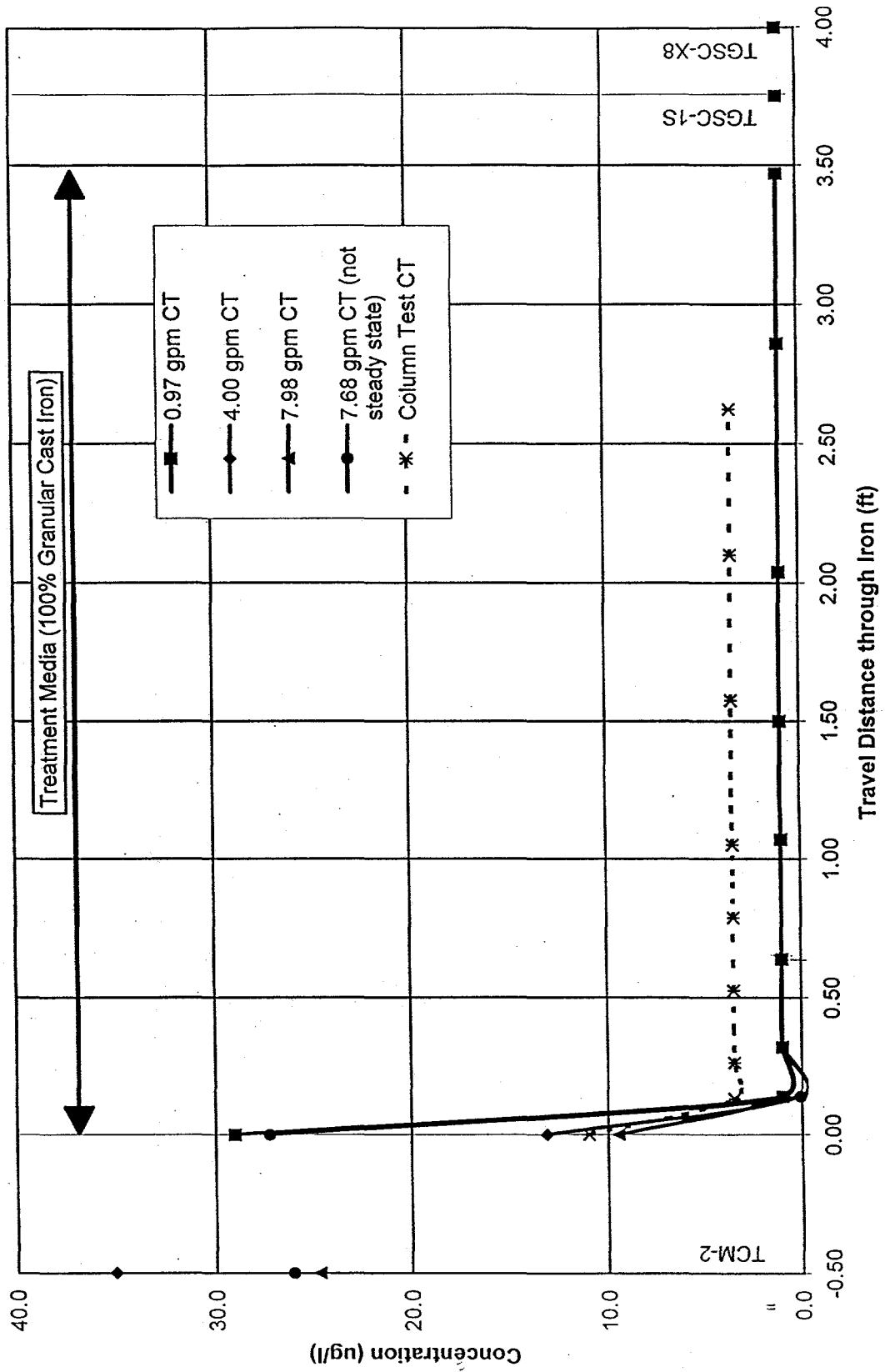

Figure 30

TCM Degradation TGSC-1 Steady State Profiles

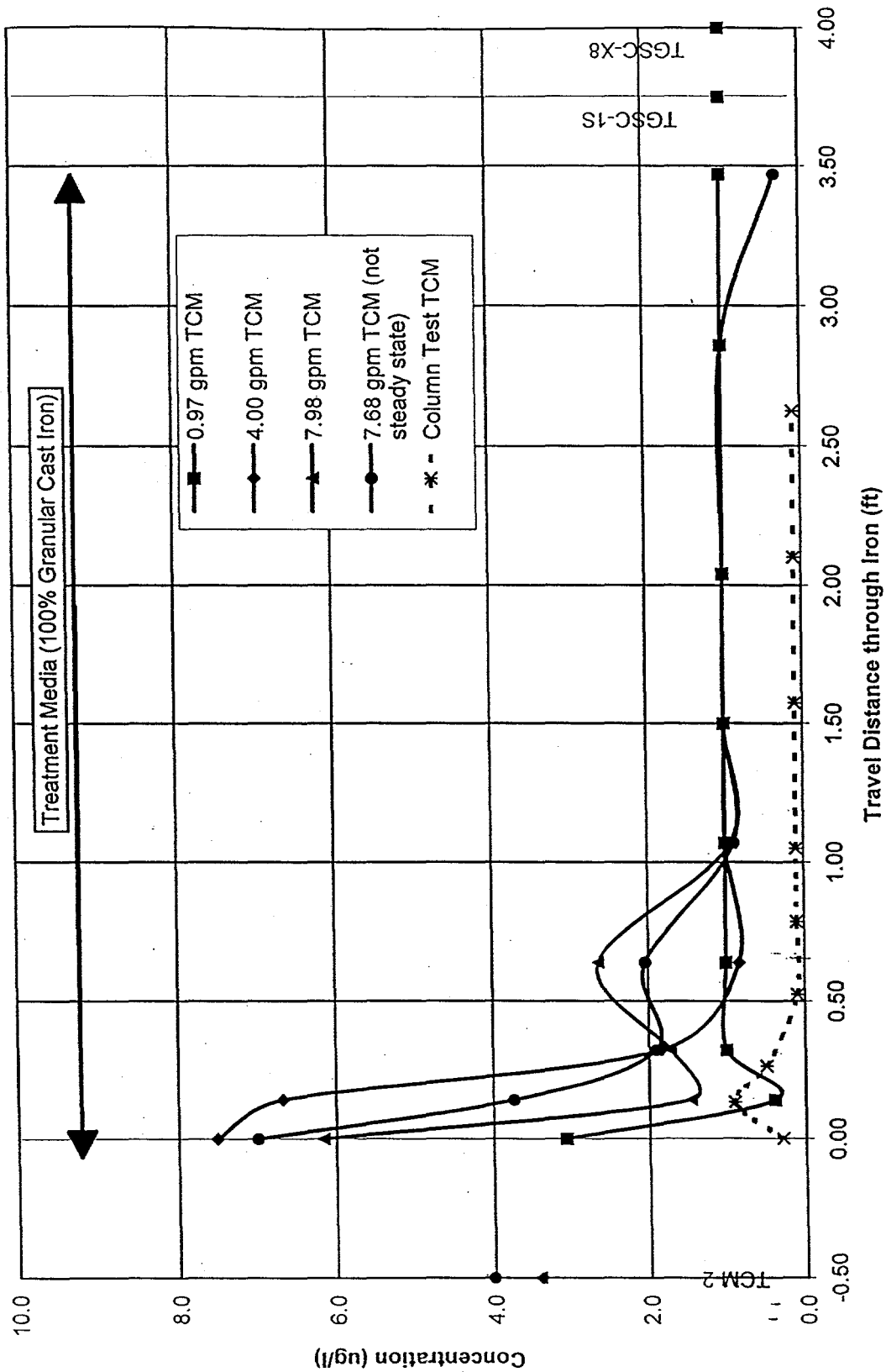

Figure 31

Flow Rate Versus TCE Discharge Concentration

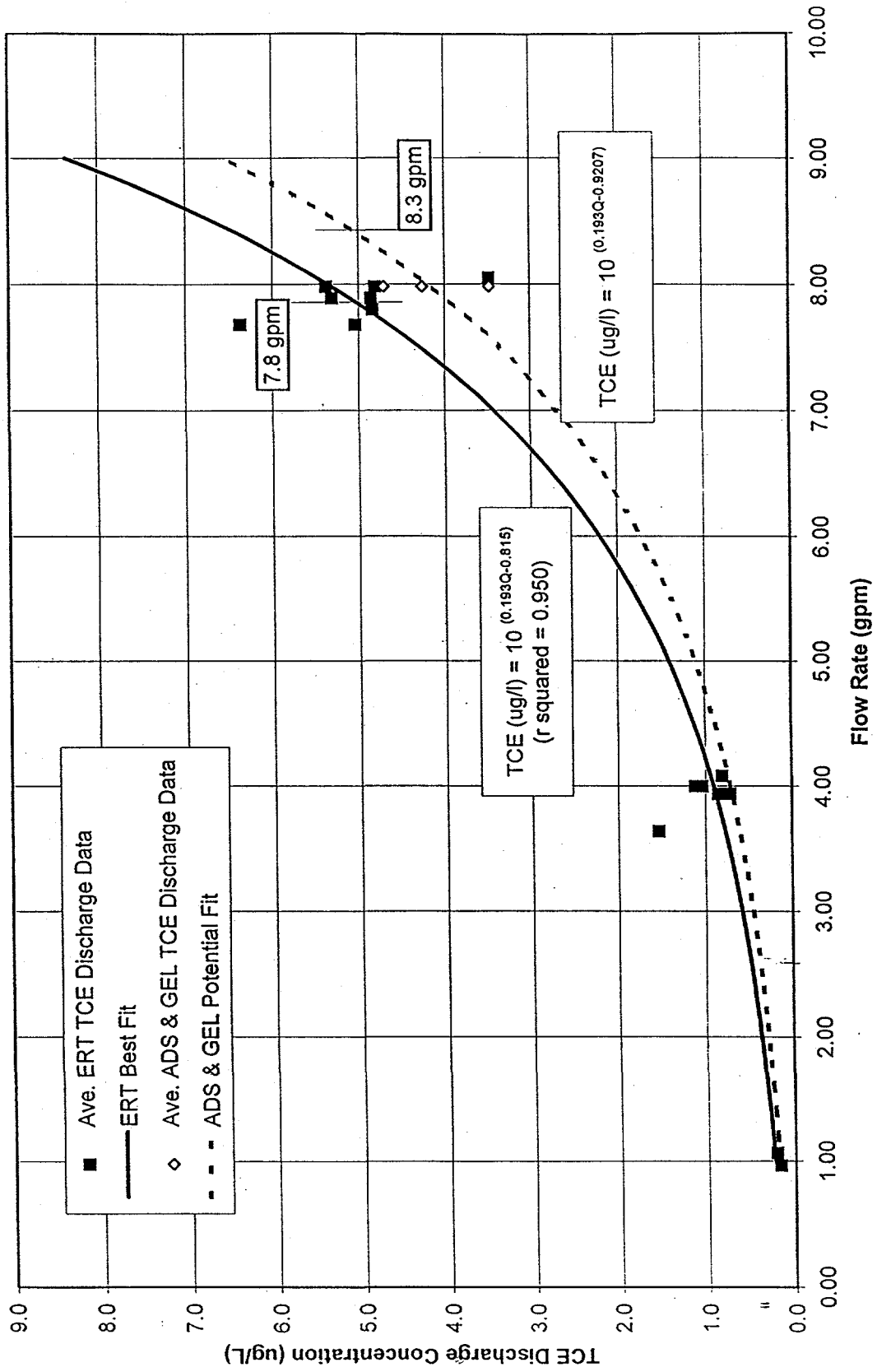

Figure 32

TNX GeoSiphon Cell Velocity Profile

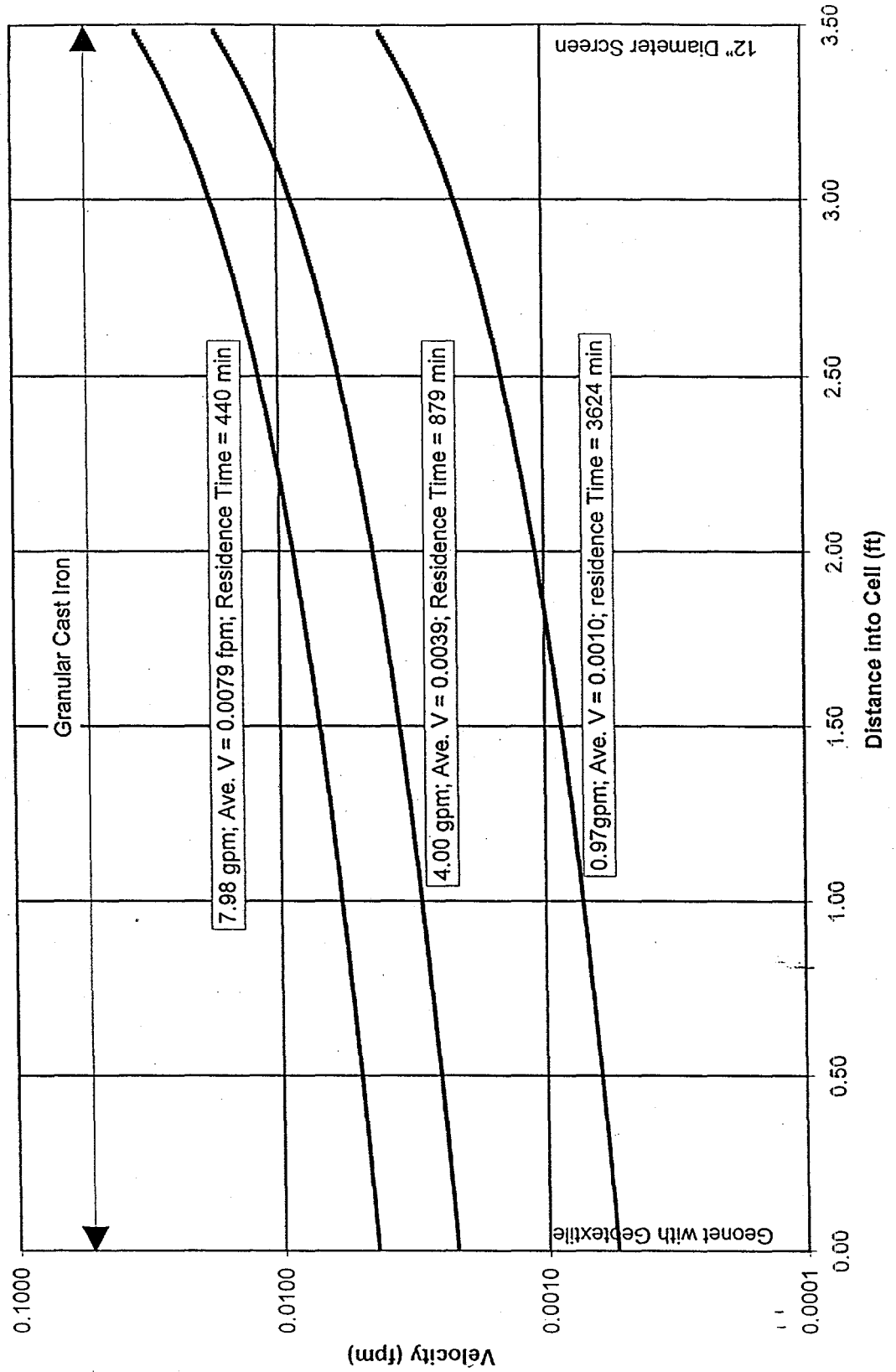

Figure 33

TCE First Order Rate Constant (k)
Laboratory Column Test

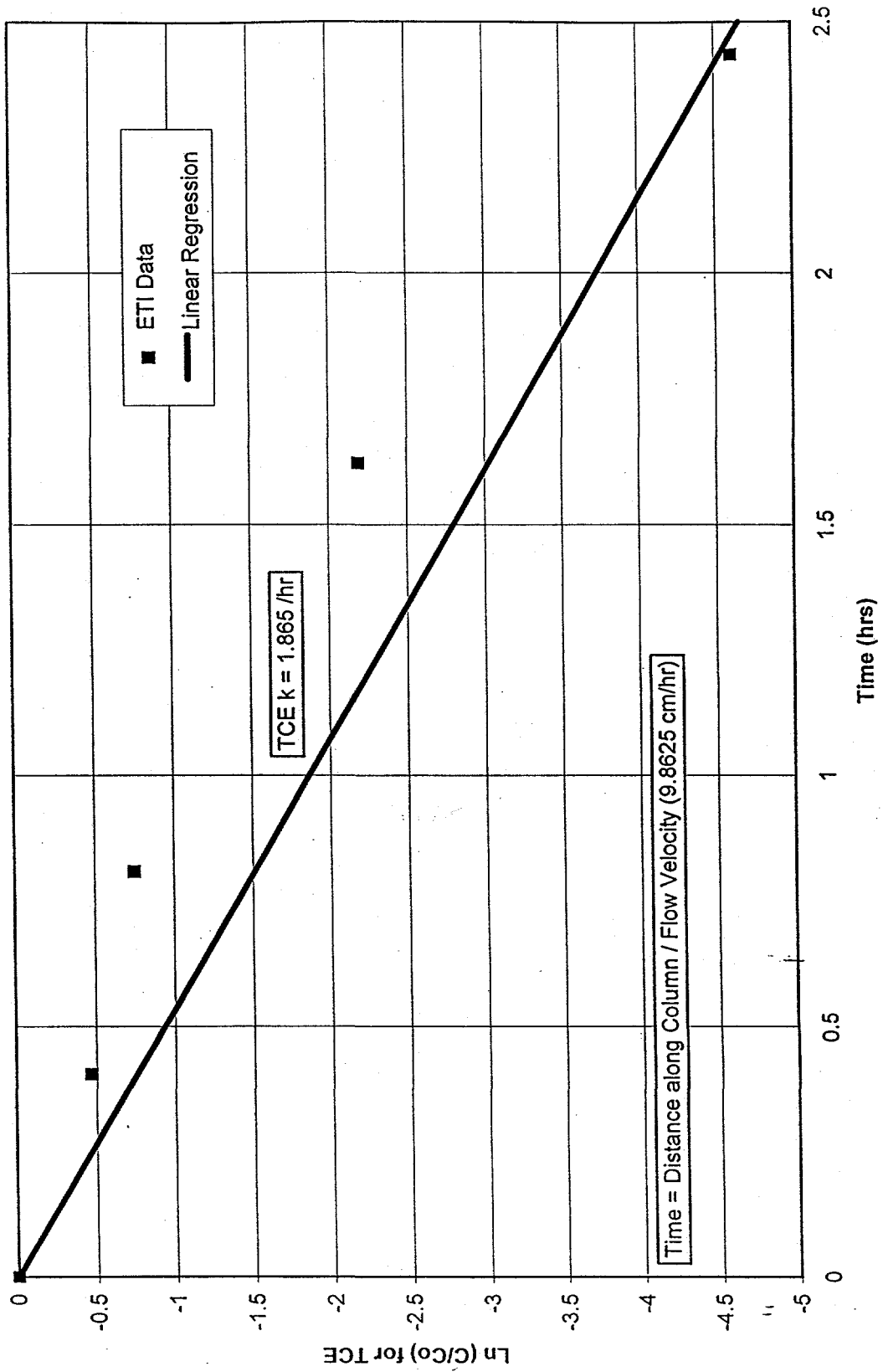

Figure 34

TCE First Order Rate Constant (k)
TGSC-1 at 0.97 gpm (9/30/97 Steady State Data)

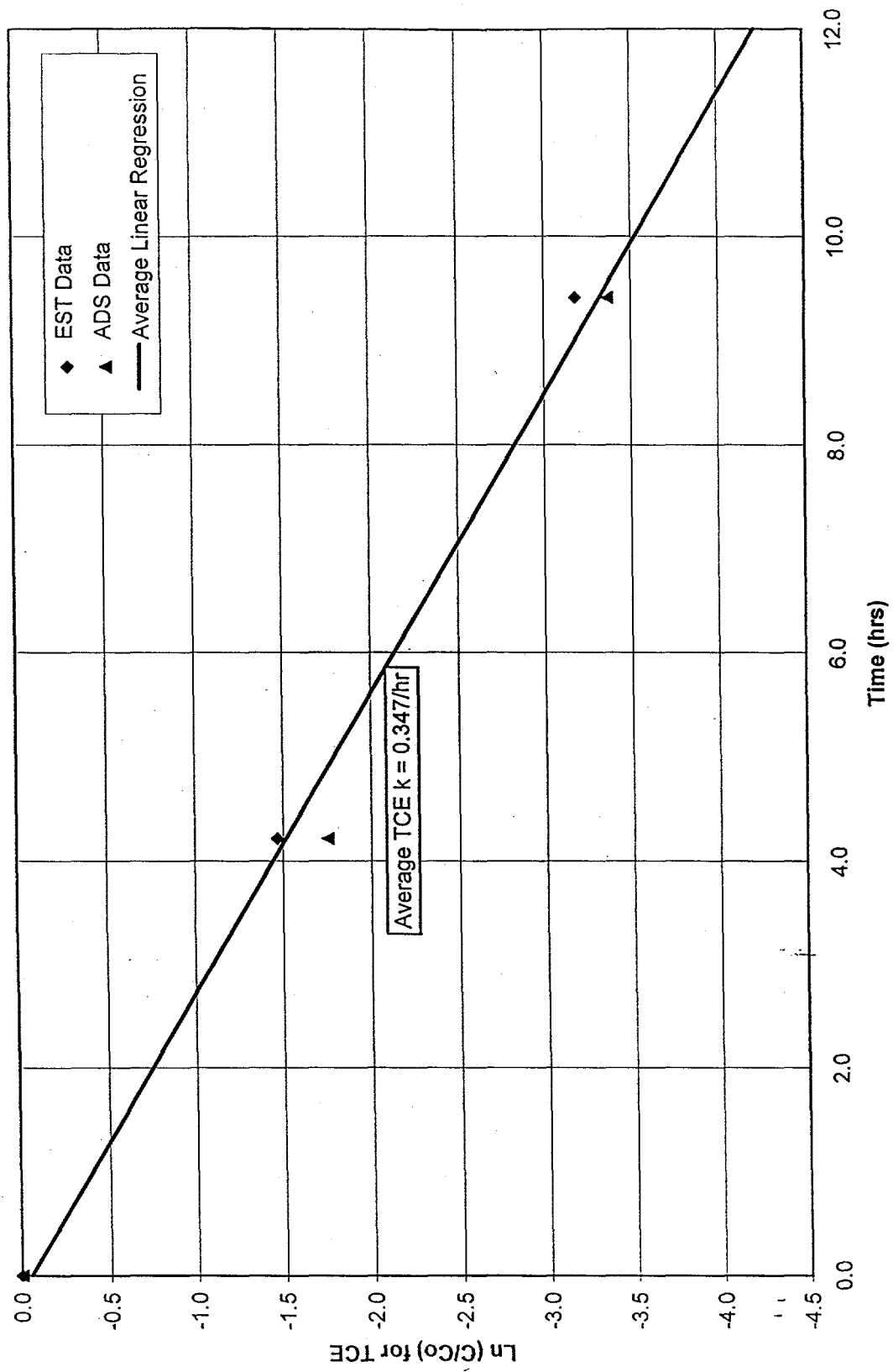

Figure 35

TCE First Order Rate Constant (k)
TGSC-1 at 4.00 gpm (11/1/97 Steady State Data)

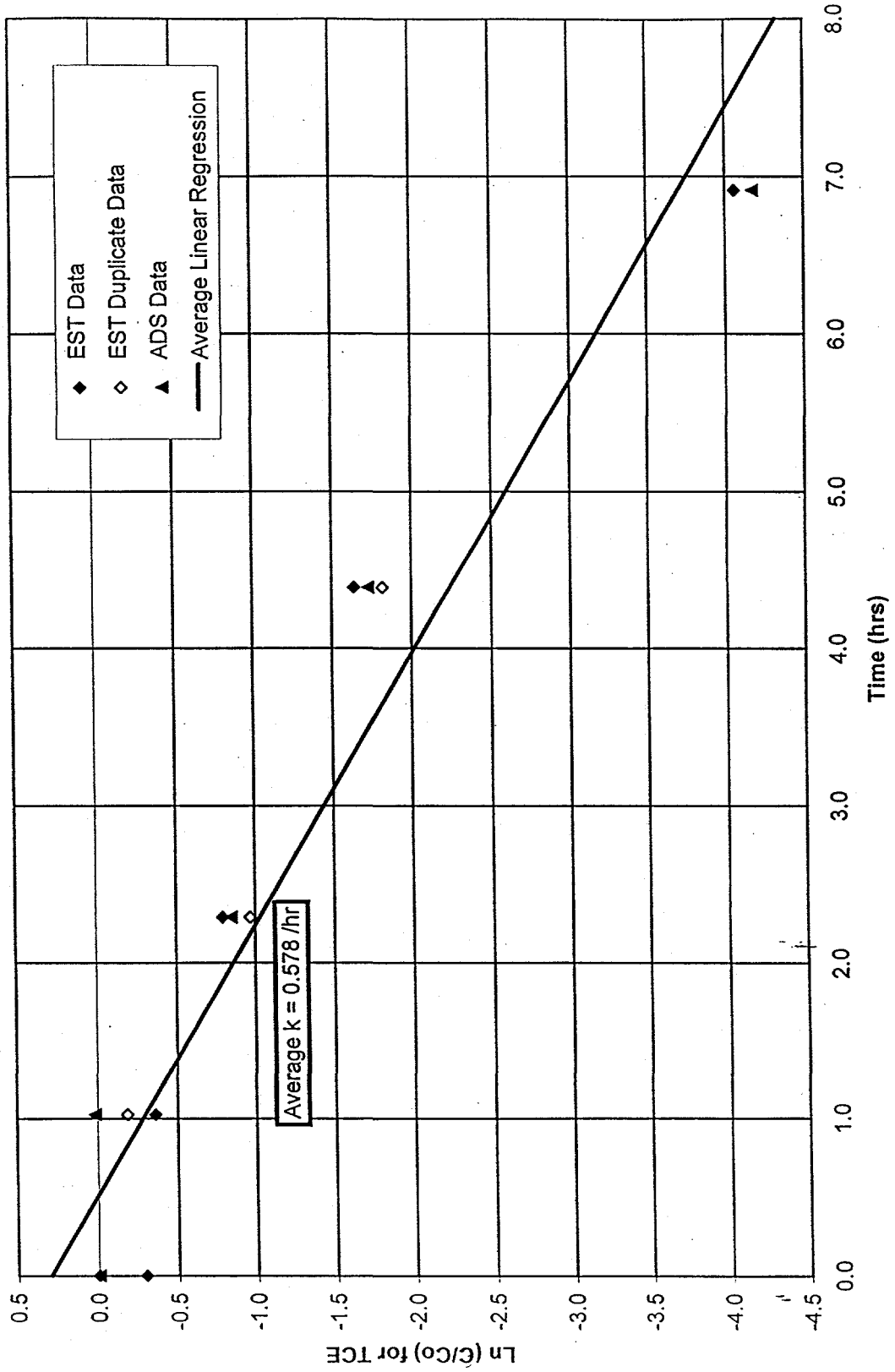

Figure 36

TCE First Order Rate Constant (k)
TGSC-1 at 7.98 gpm (12/16/97 Steady State Data)

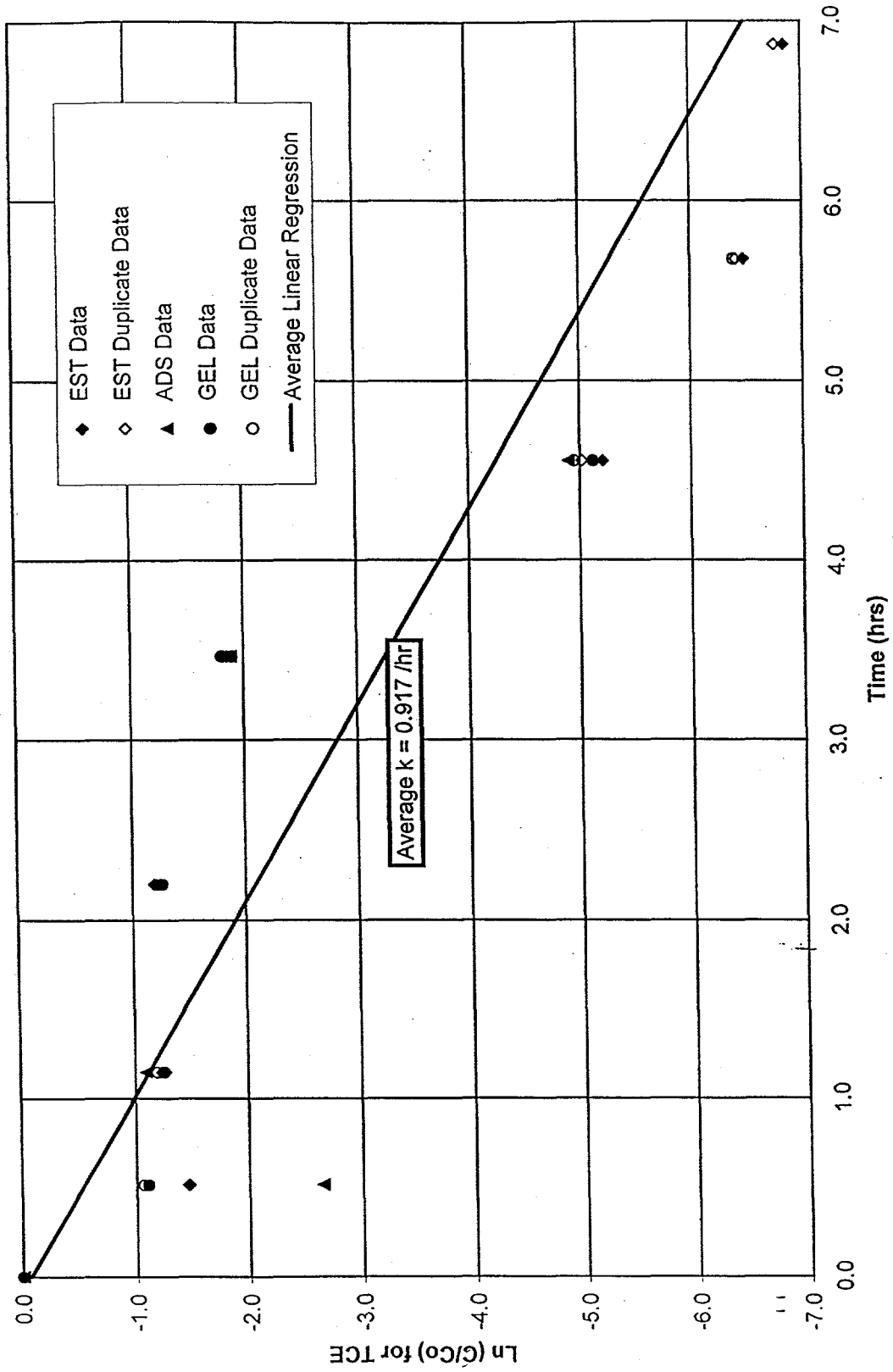

Figure 37

TCE First Order Rate Constant (k)
TGSC-1 at 7.68 gpm (12/2/97 Data)

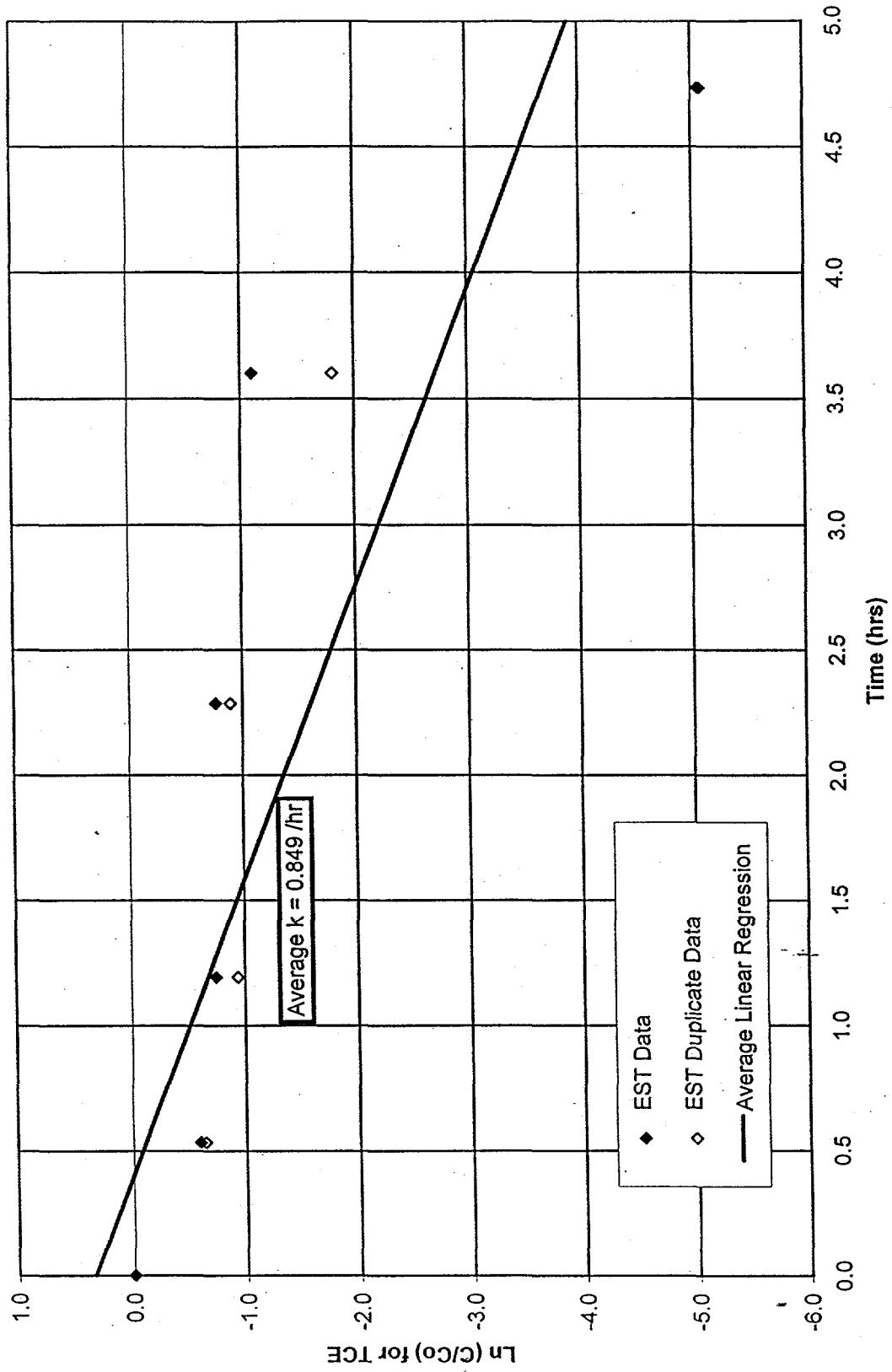

Figure 38

Flow Rate (Q) Versus Steady State First Order Rate Constant (k)

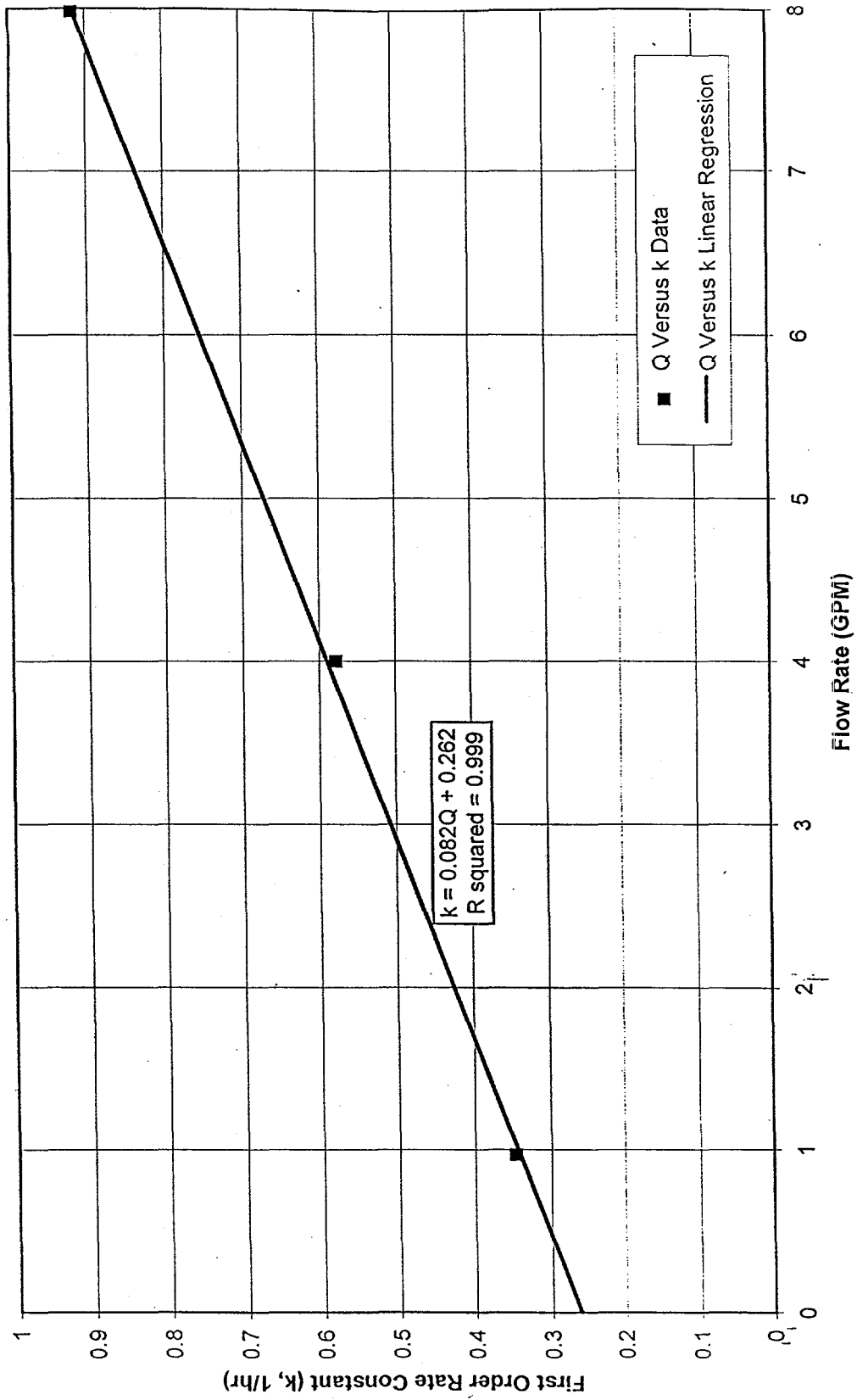

Figure 39

Flow Rate (Q) Versus First Order Rate Constant (k)

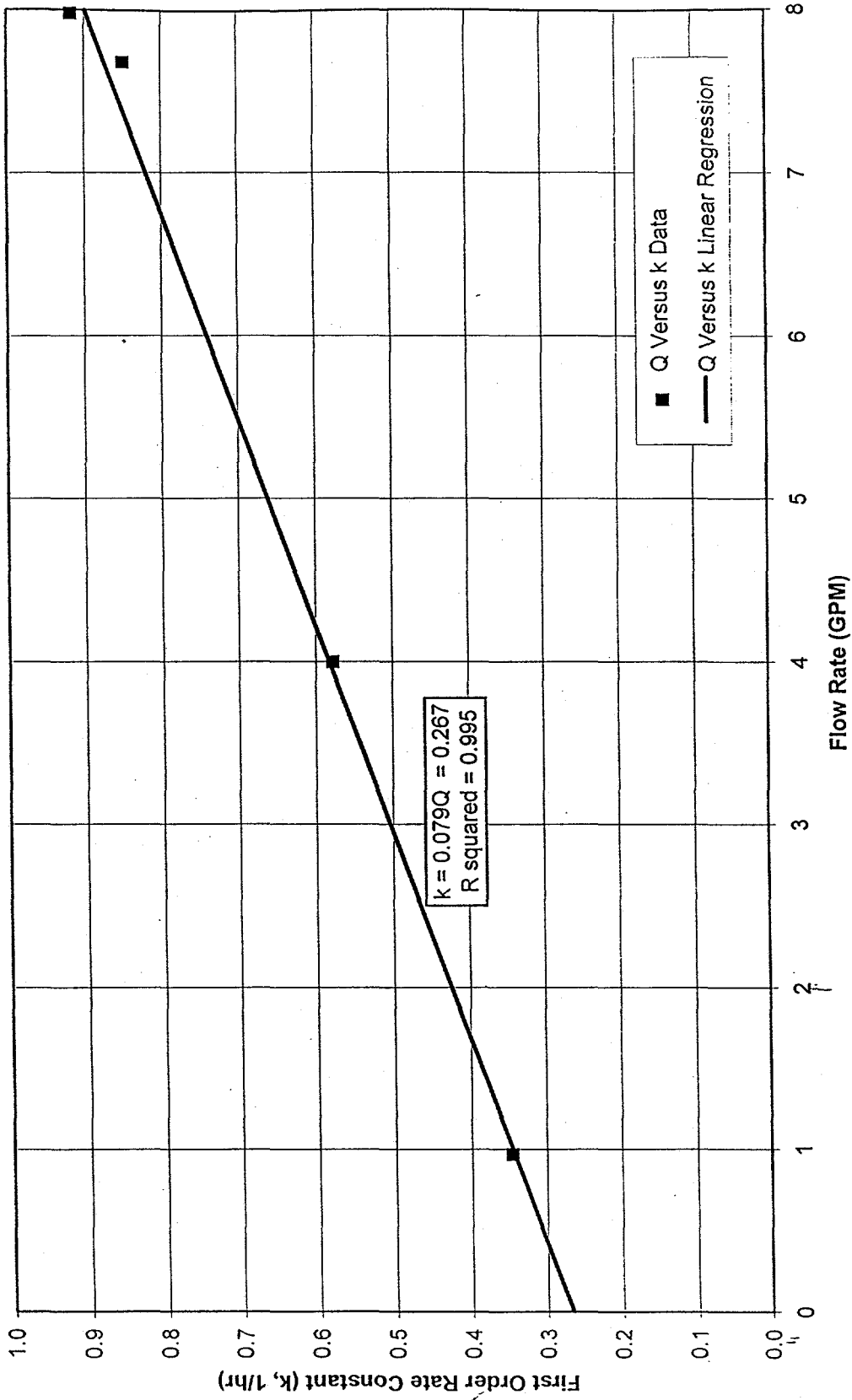

Figure 40

Iron TGSC-1 Profile at Steady State

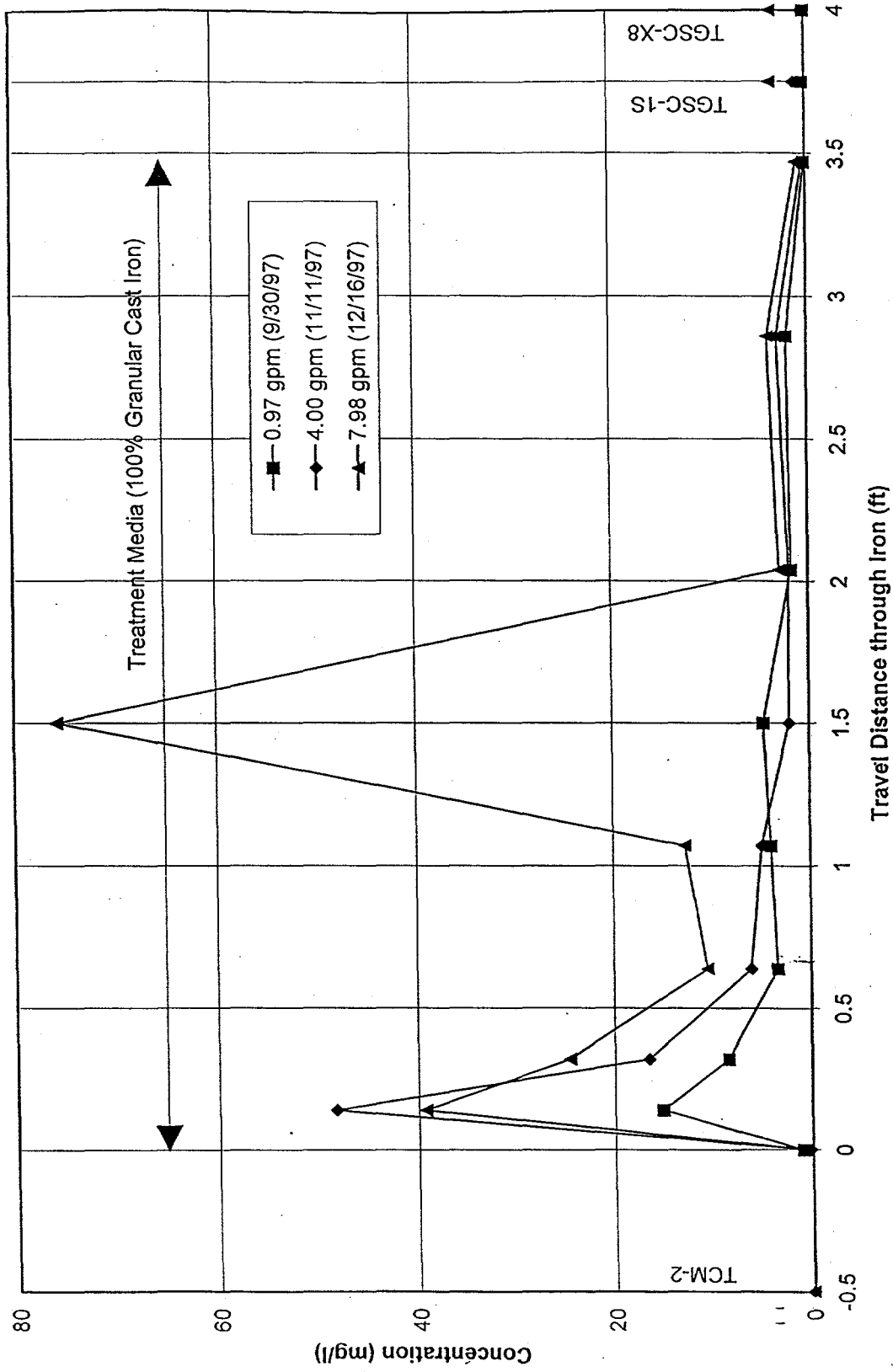

Figure 41

Nitrate TGSC-1 Profile at Steady State

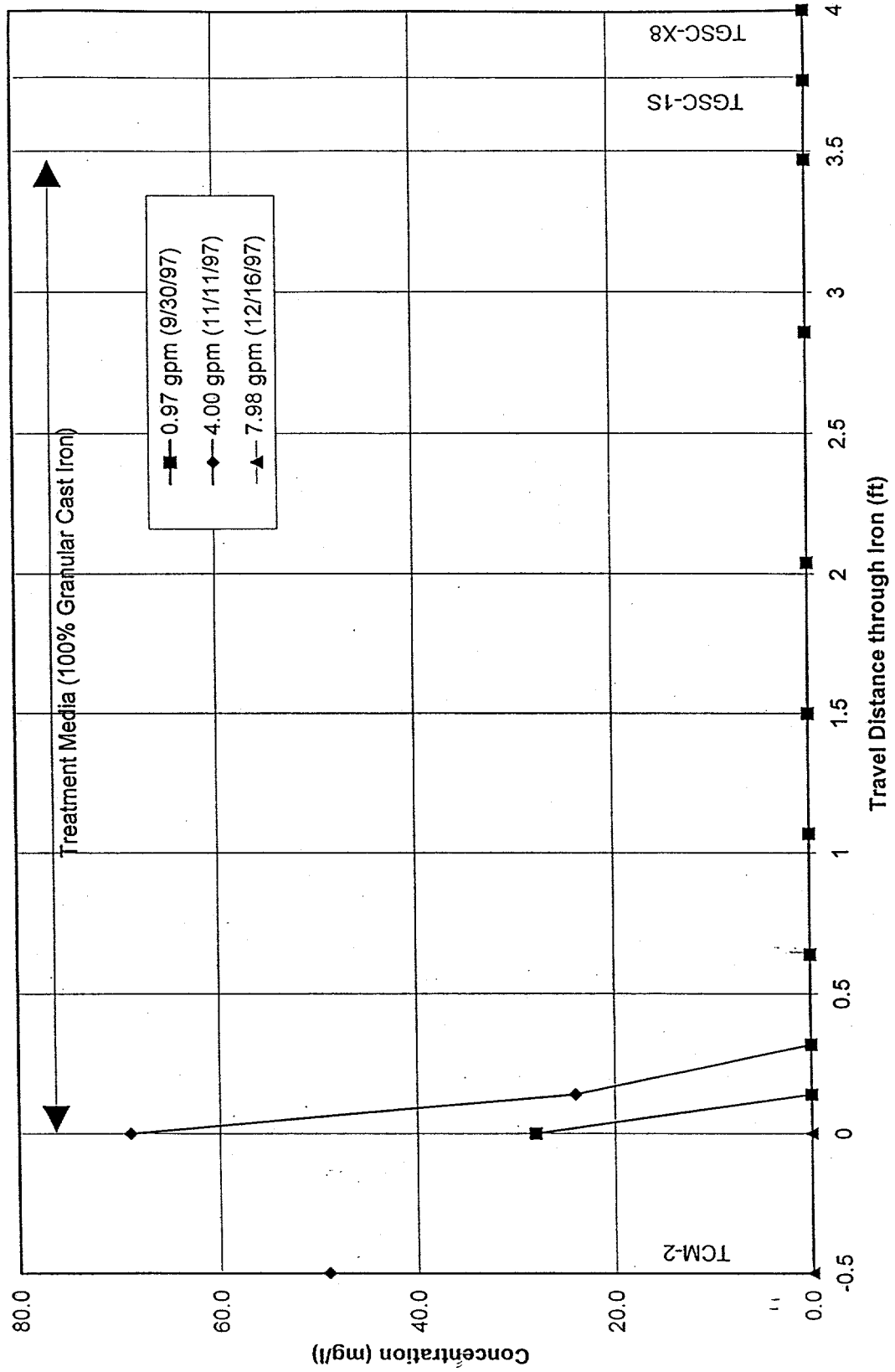

Figure 42

Sulfate TGSC-1 Profile at Steady State

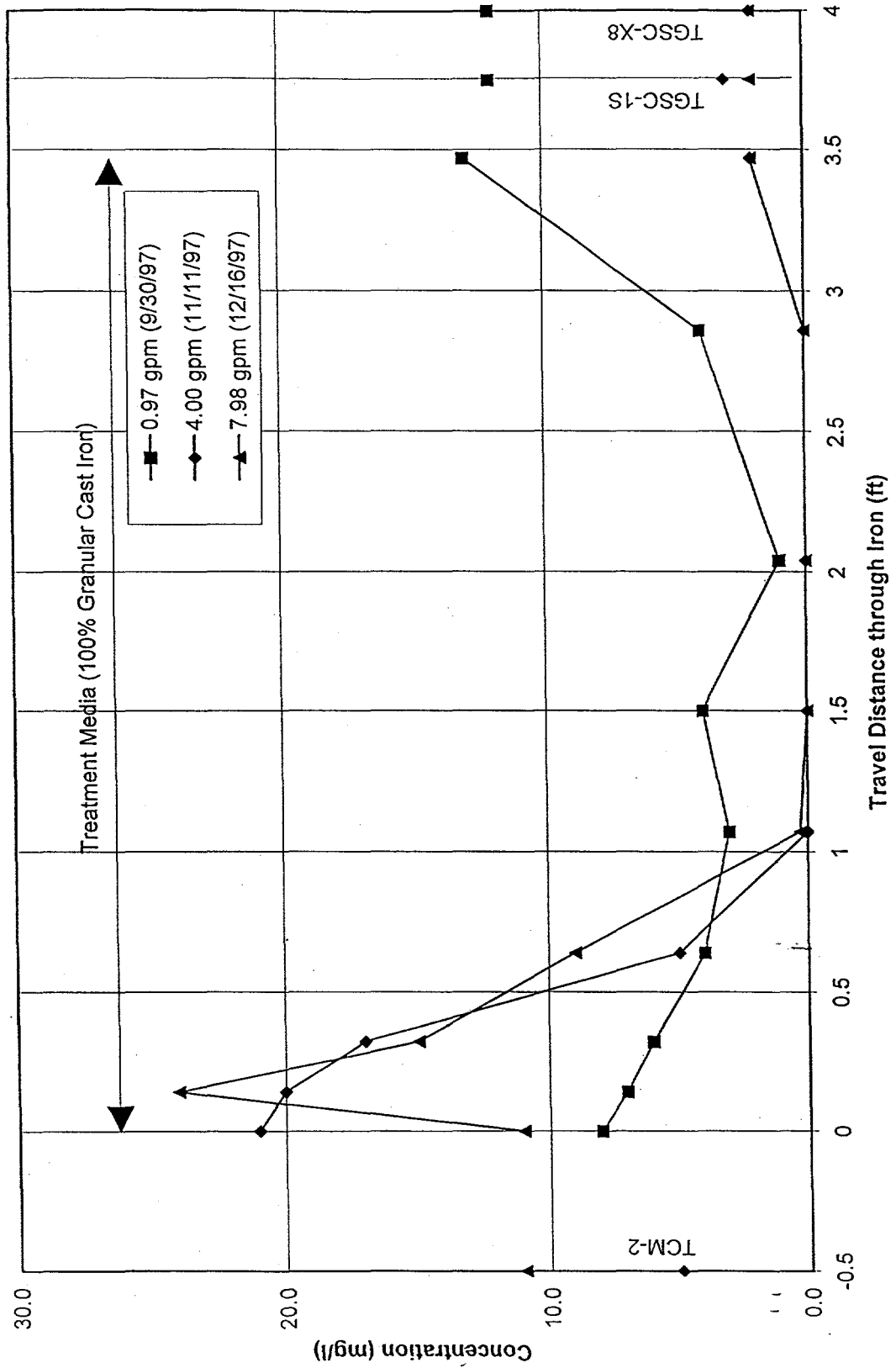

Figure 43

Calcium TGSC-1 Profile at Steady State

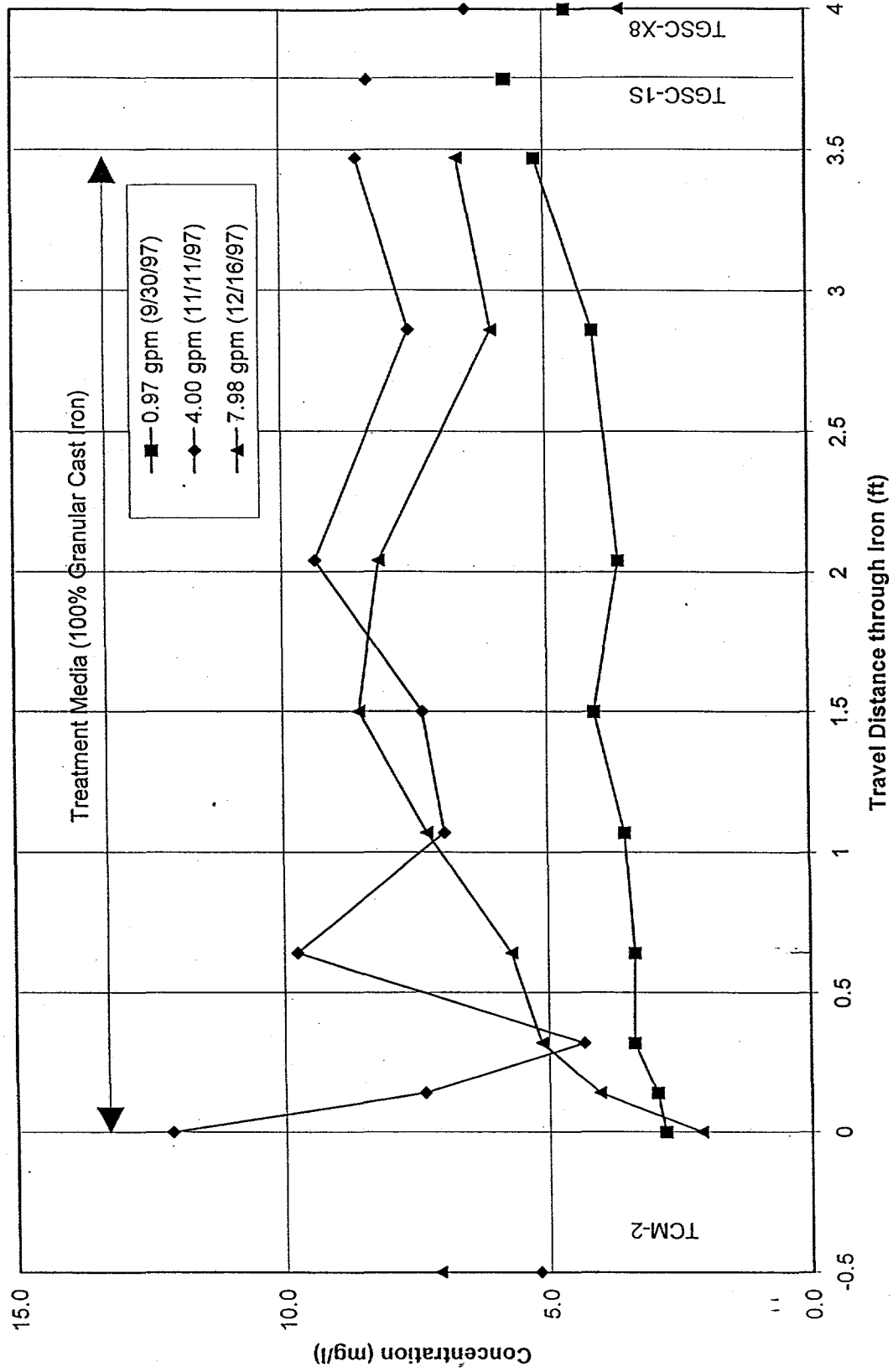

Figure 44

Magnesium TGSC-1 Profile at Steady State

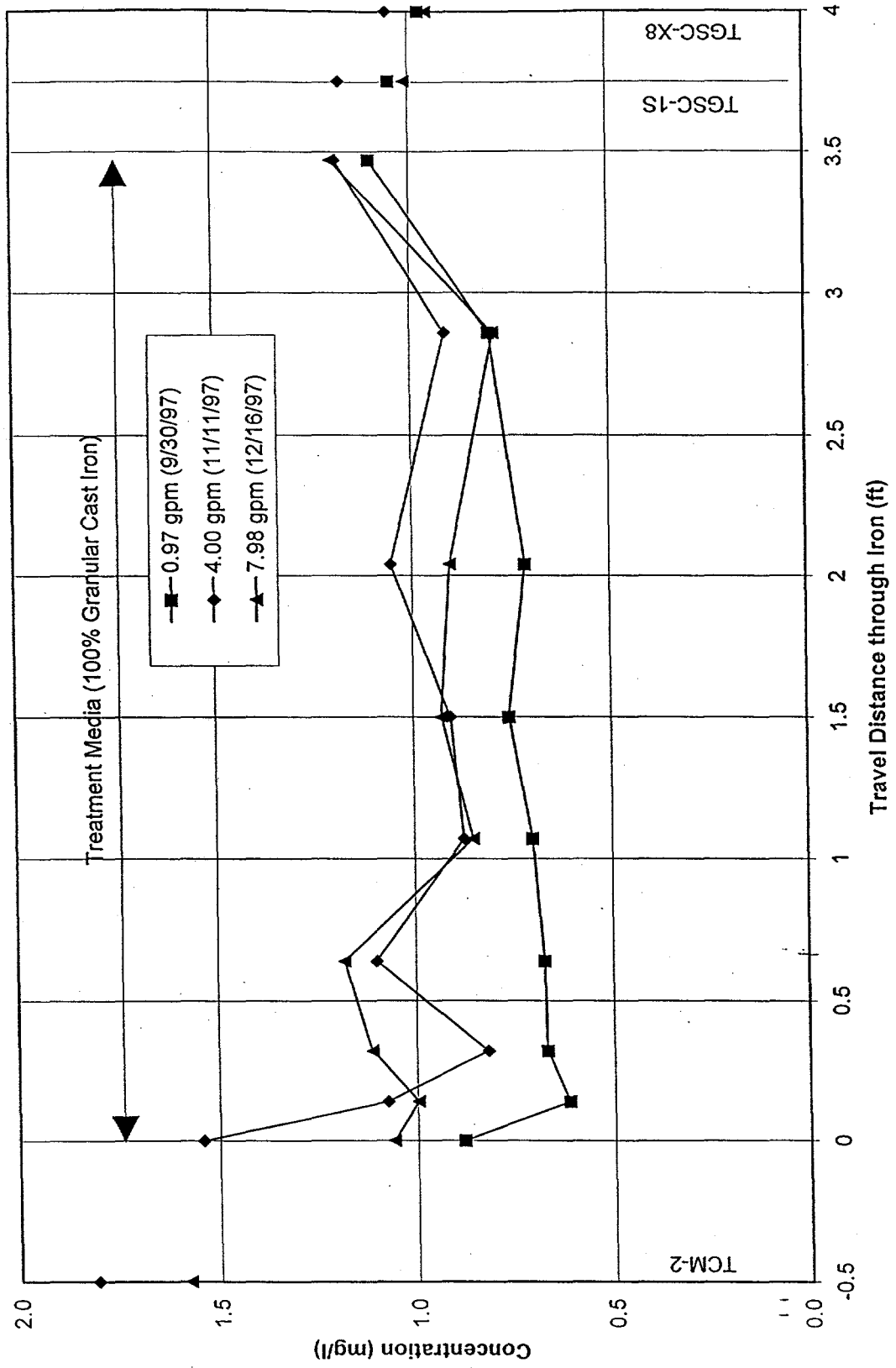

Figure 45

Sodium TGSC-1 Profile at Steady State

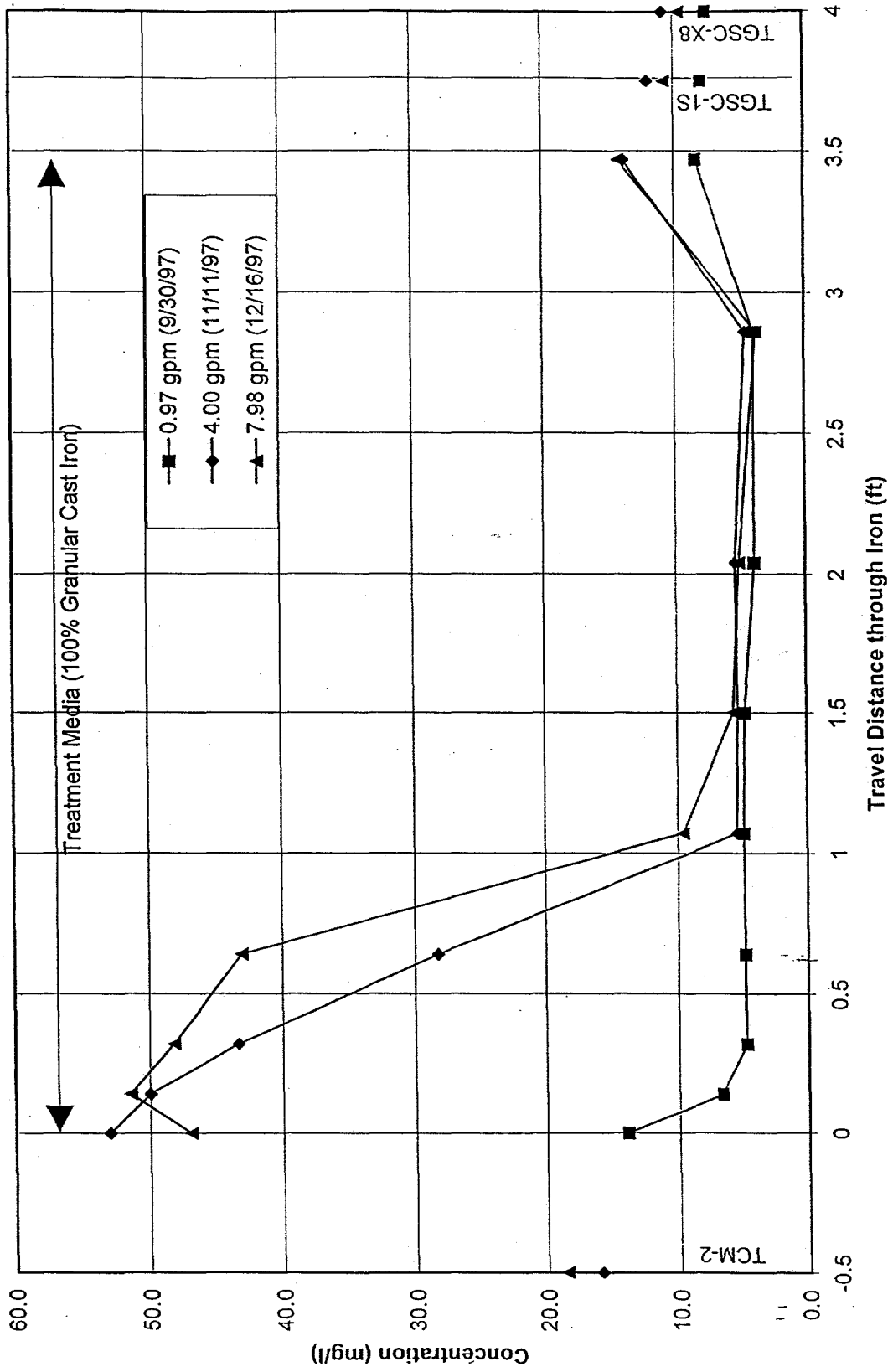

Figure 46

Aluminum TGSC-1 Profile at Steady State

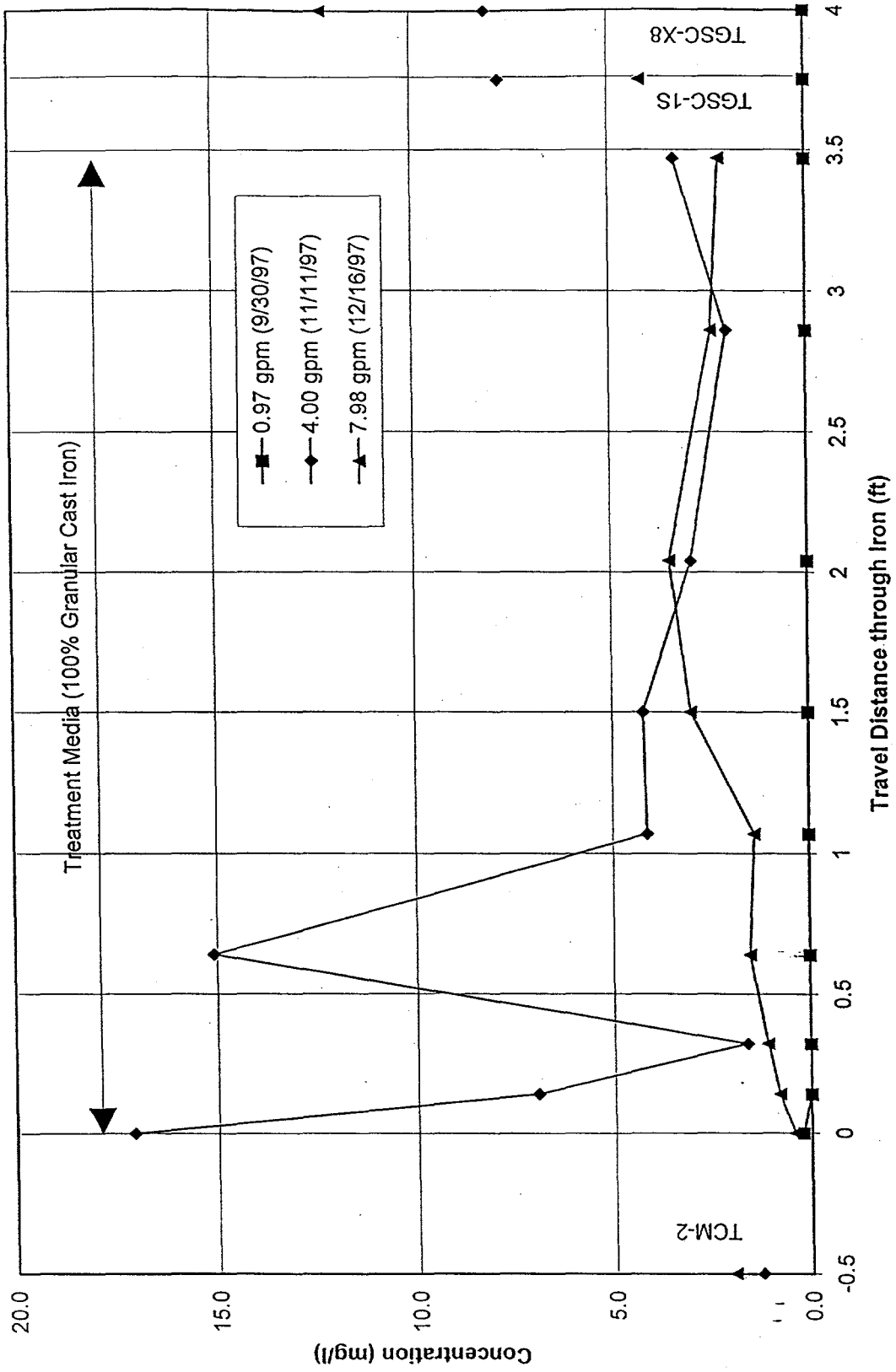

Figure 47

Manganese TGSC-1 Profile at Steady State

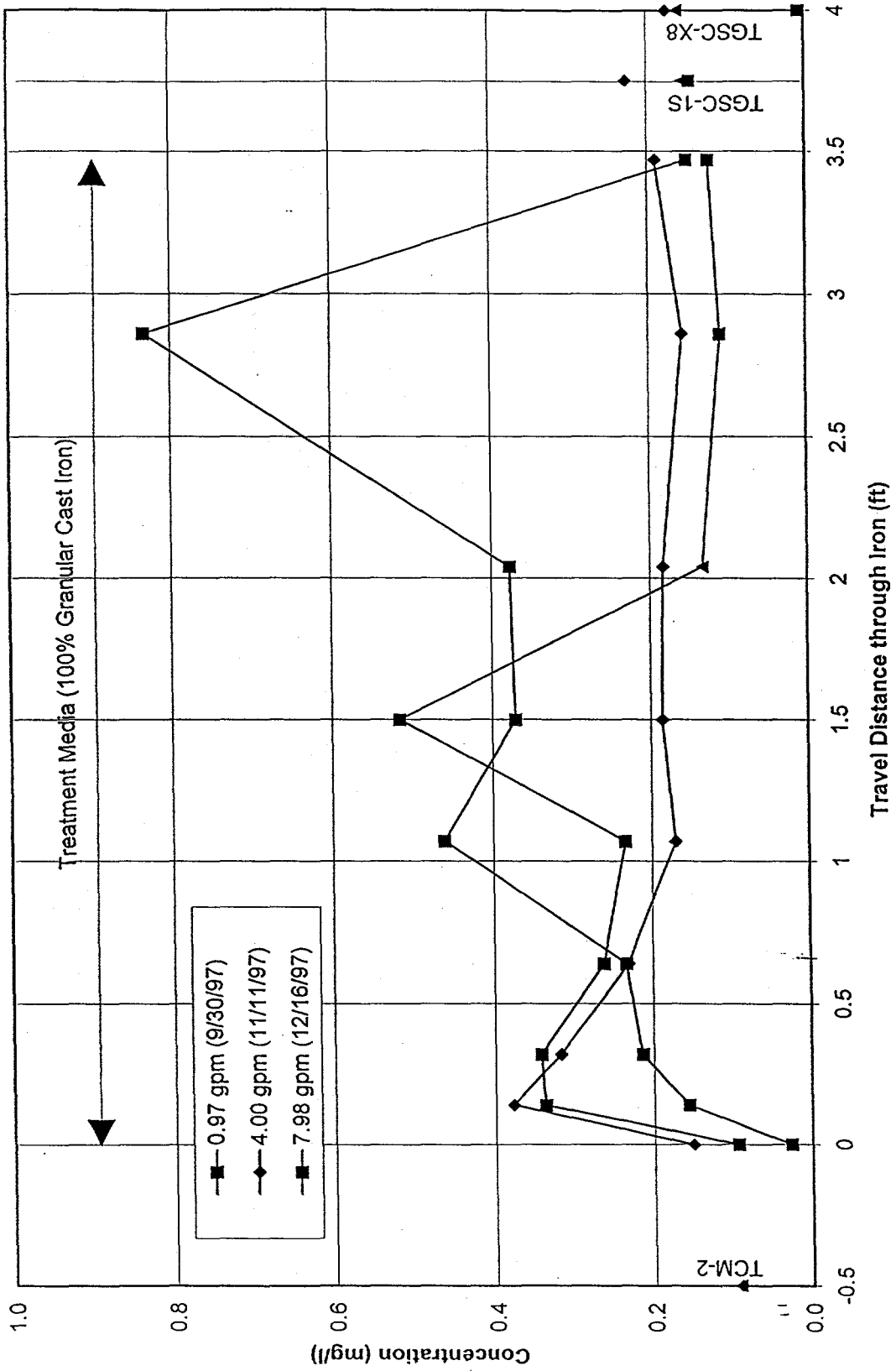

Figure 48

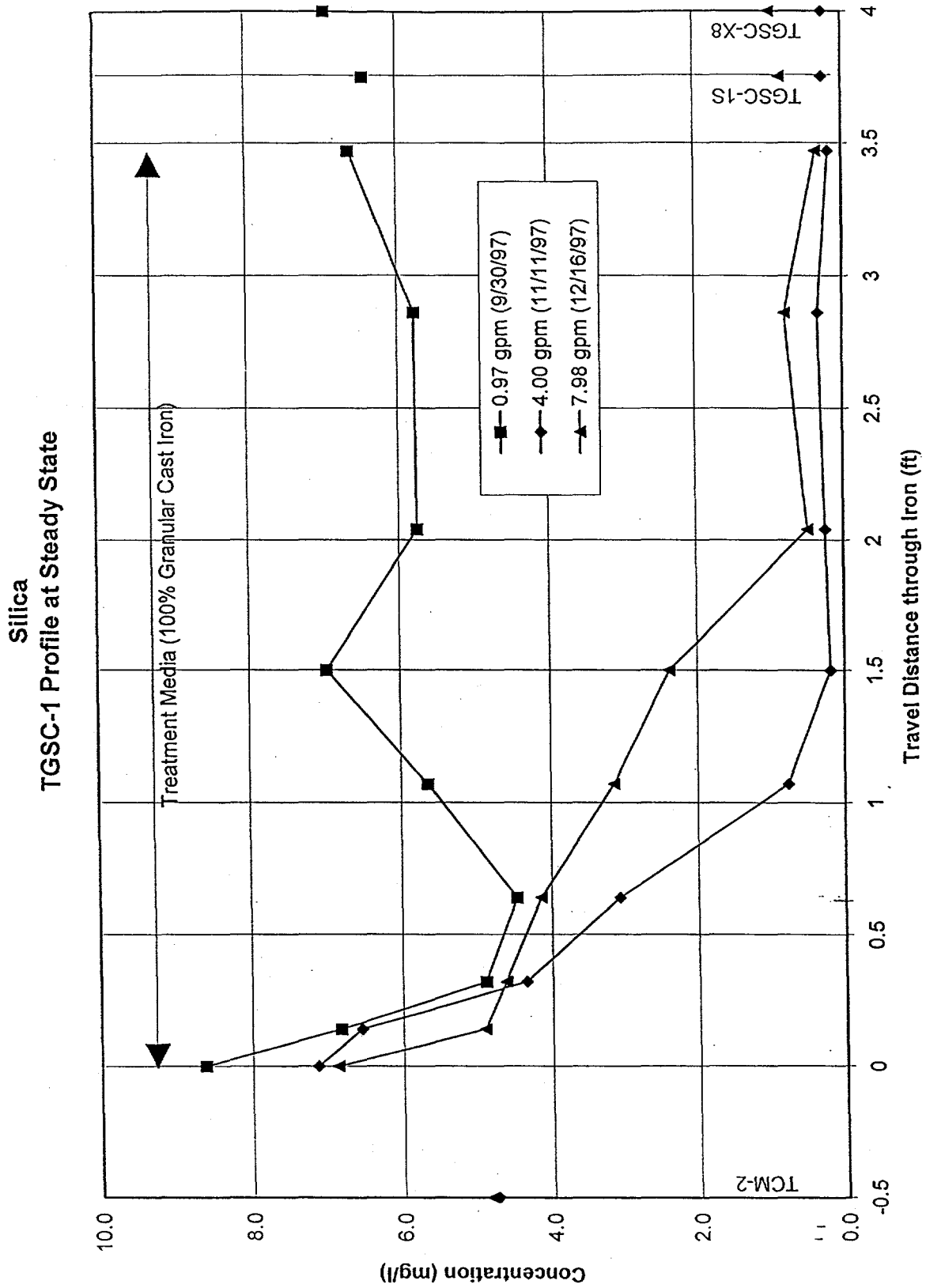

Fig. 49
XRD - TGSC-1 Screen Zone Sludge

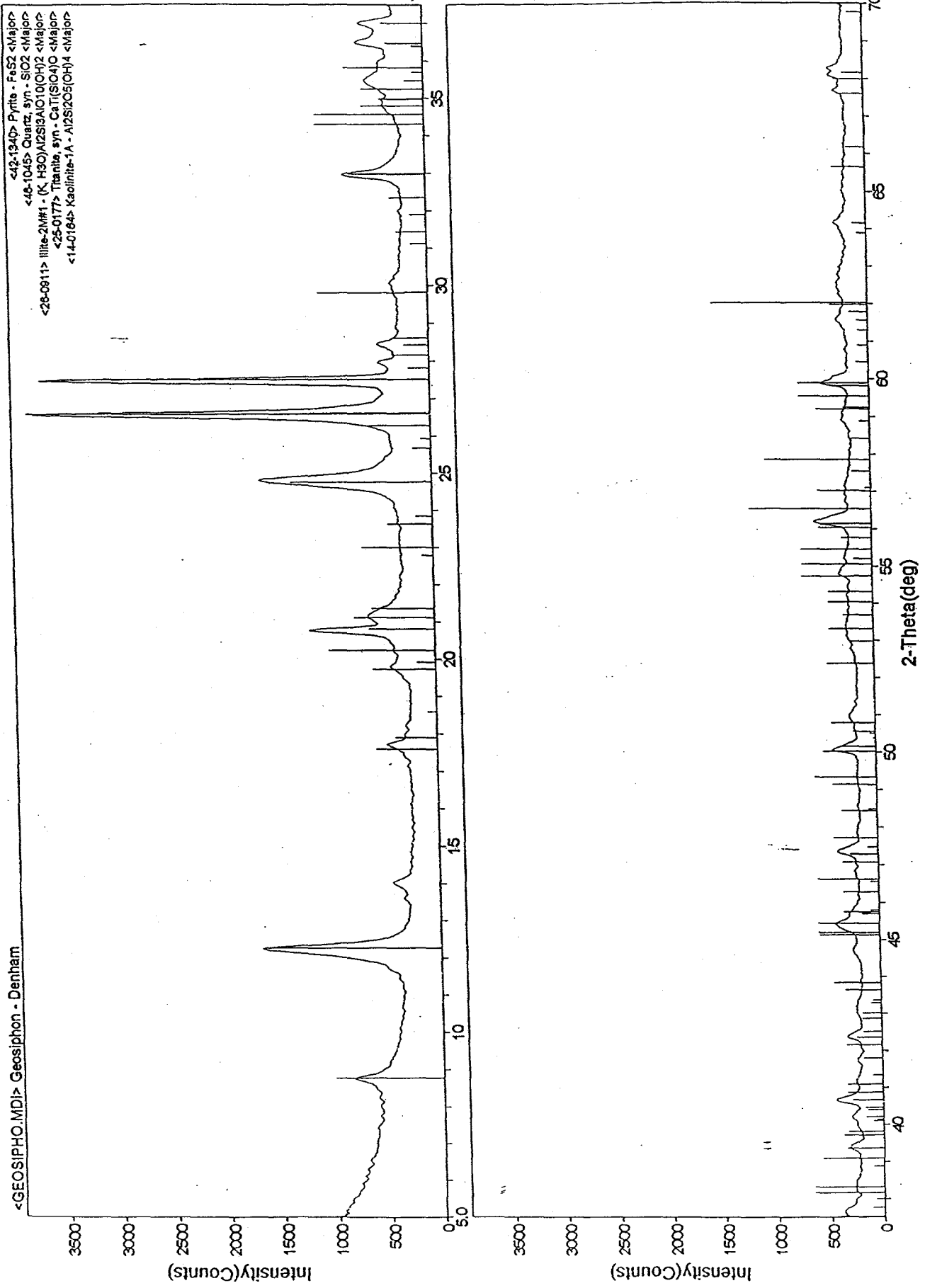

Figure 50
XRD - TGSC-1 Discharge Pipe Sludge

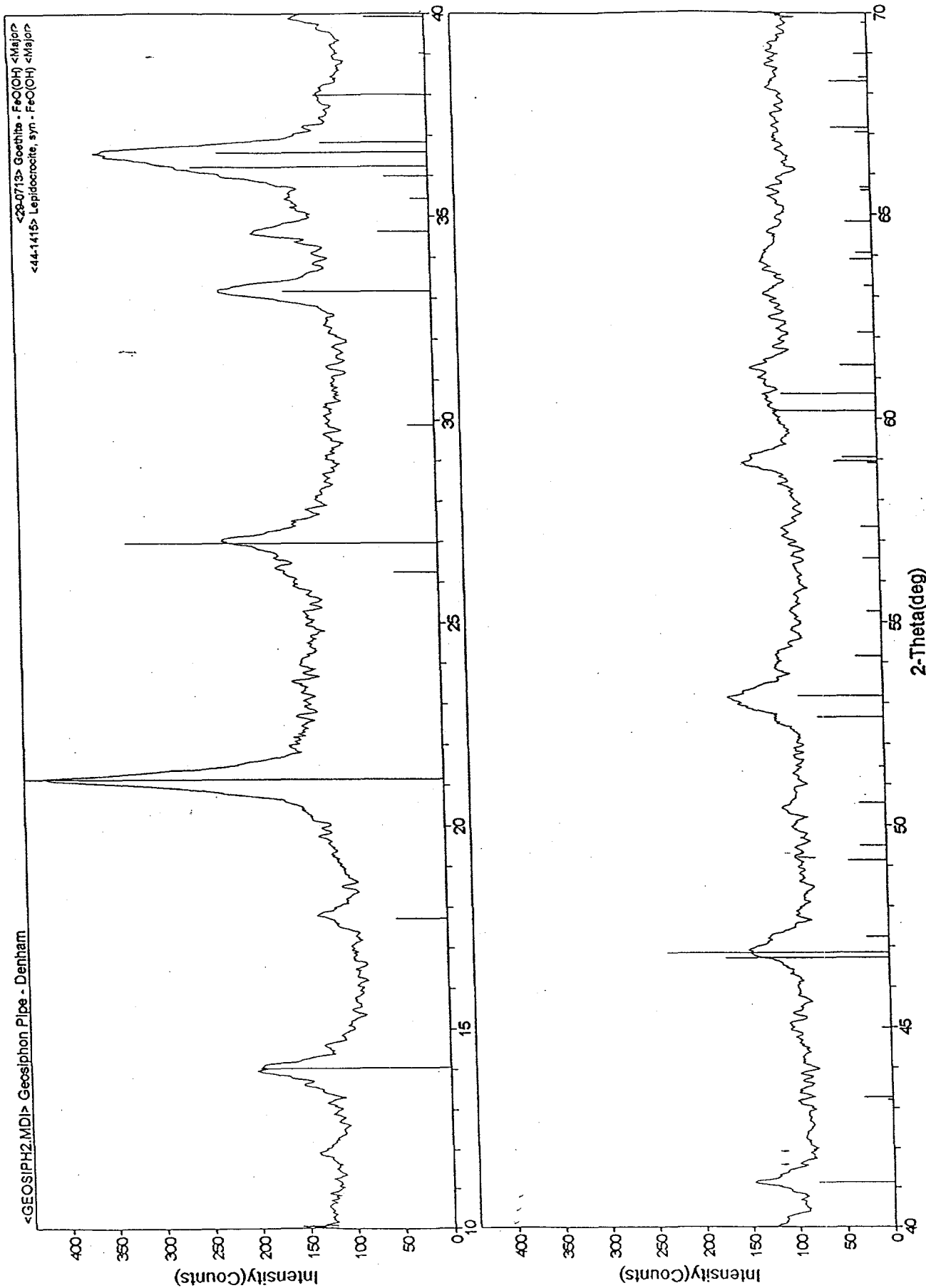

Figure 51

Microbial Density
TGSC-1 Profile at ~7gpm (1/21/98 Data)

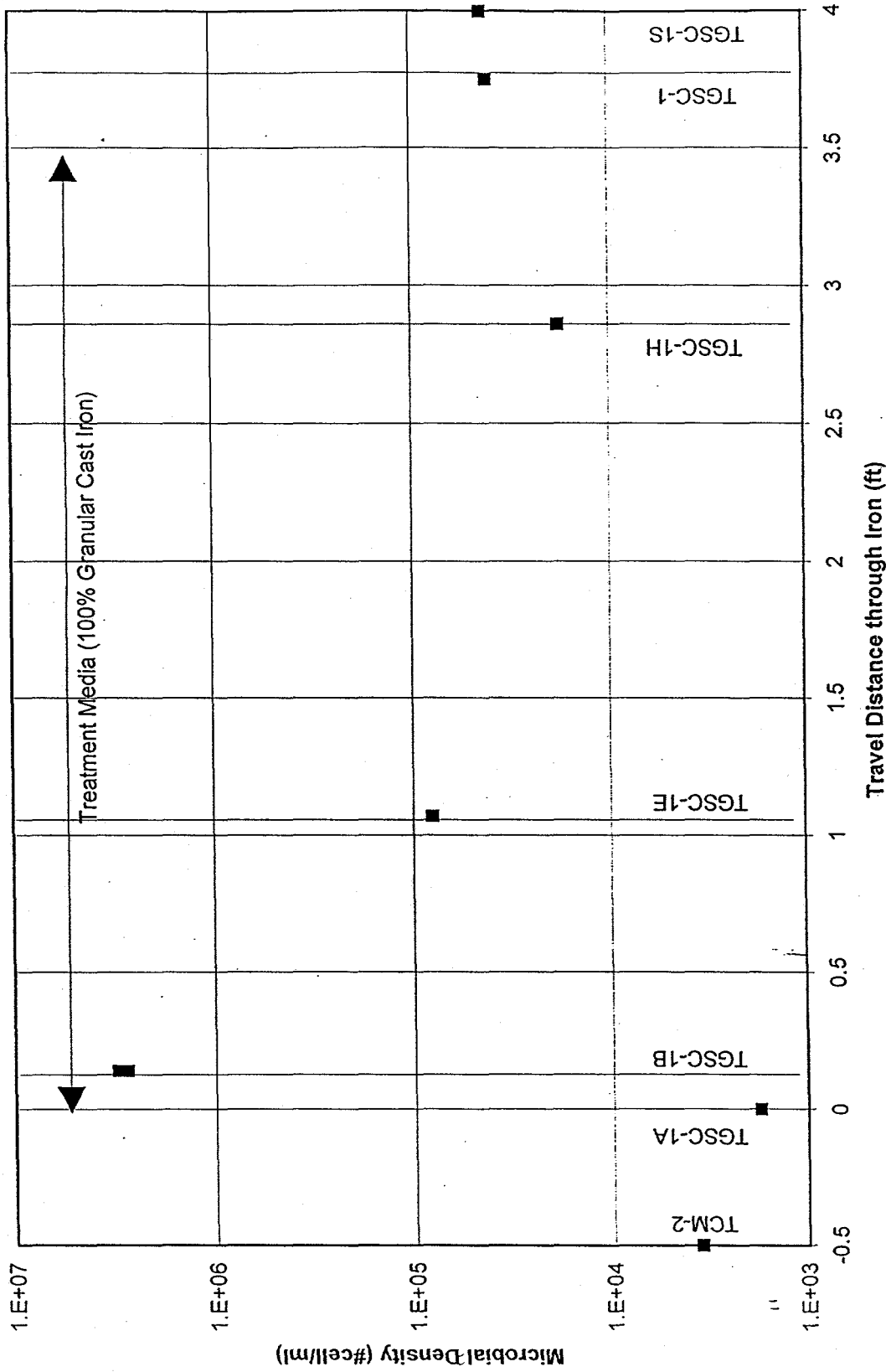

Figure 52

TSGC-1 Hydraulic Response Versus Pumpage & Rainfall

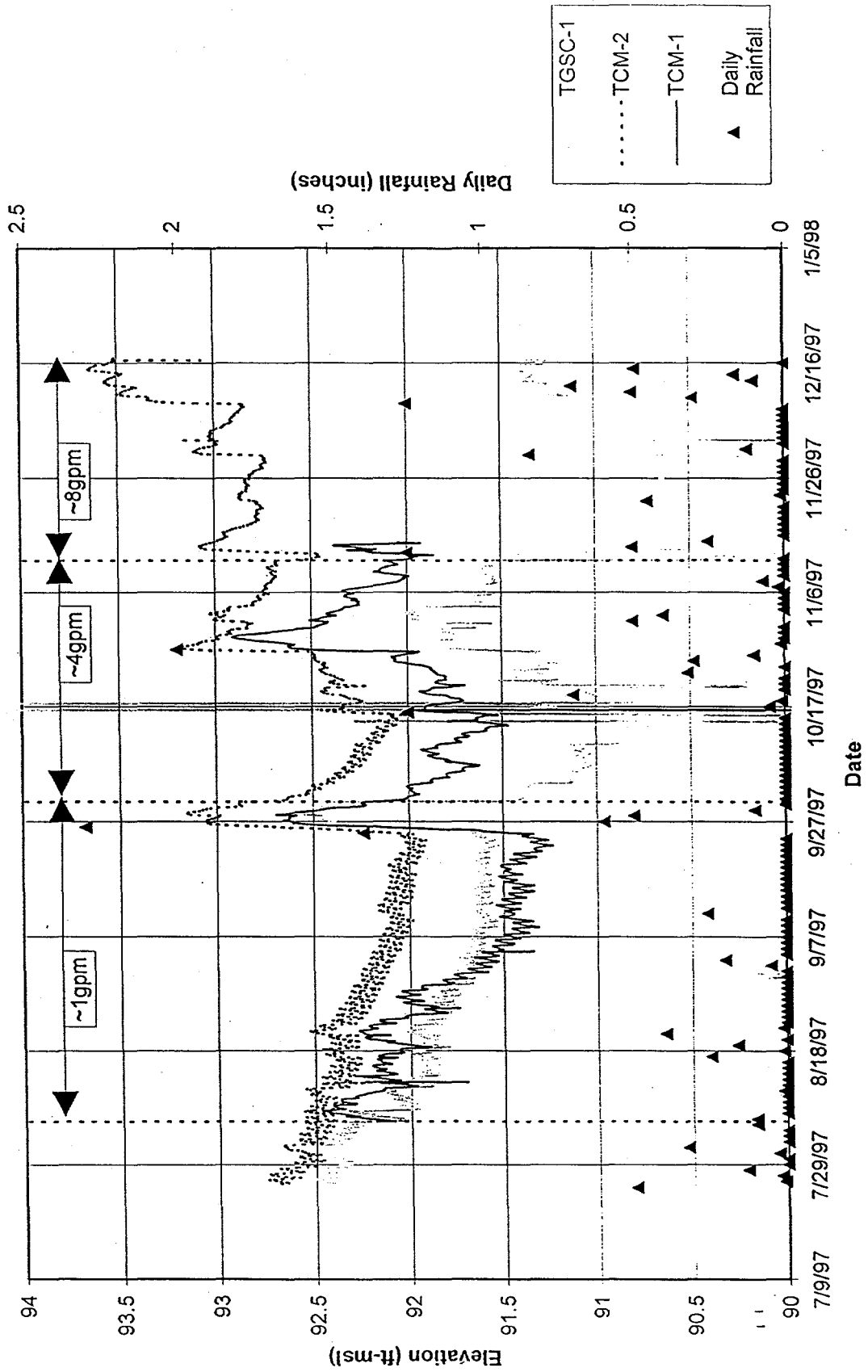

Figure 53

TCM-2 Time-Drawdown Data Versus Neuman Curve

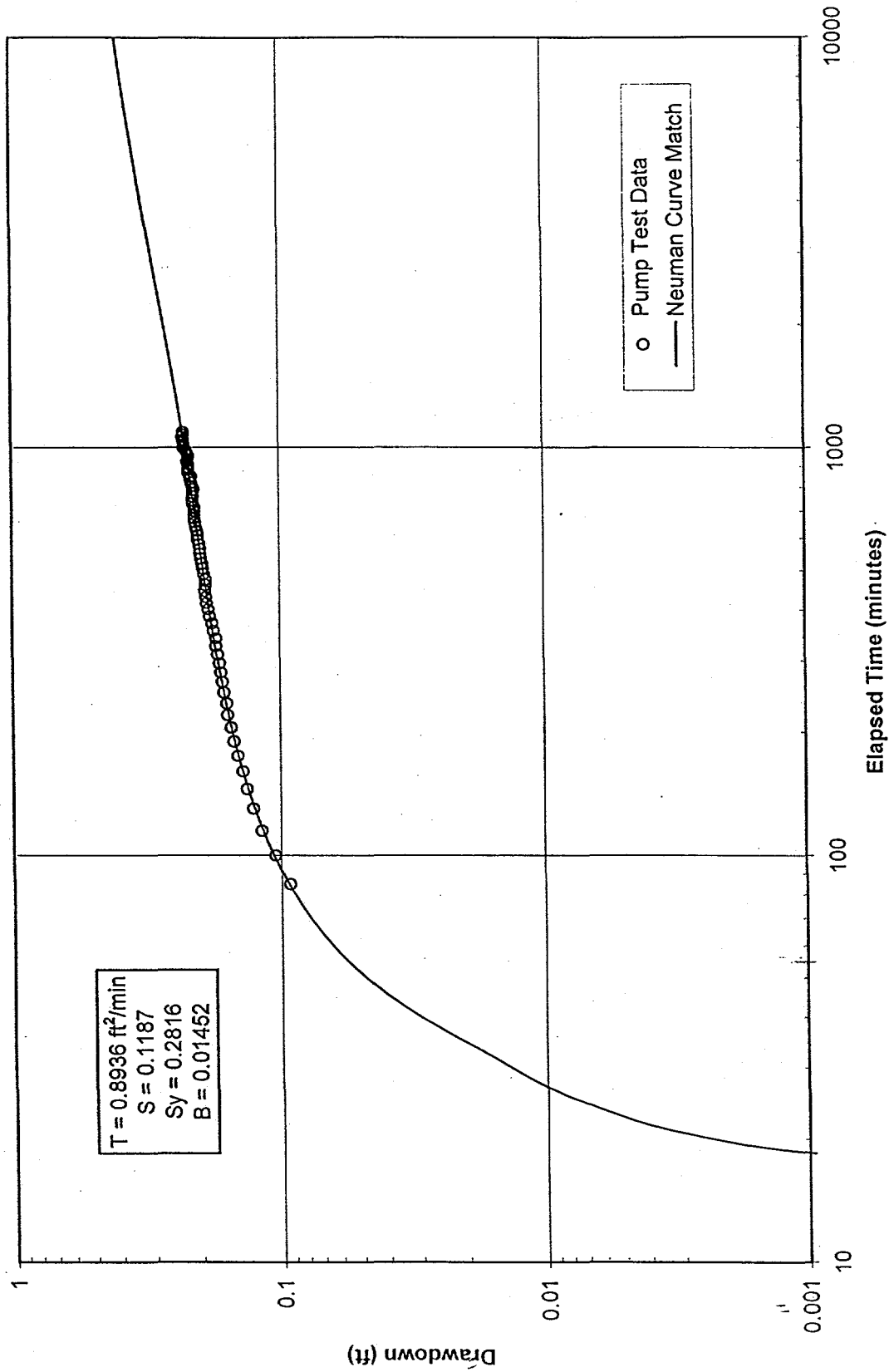

Figure 54

TCM-1 Time-Drawdown Data Versus Neuman Curve

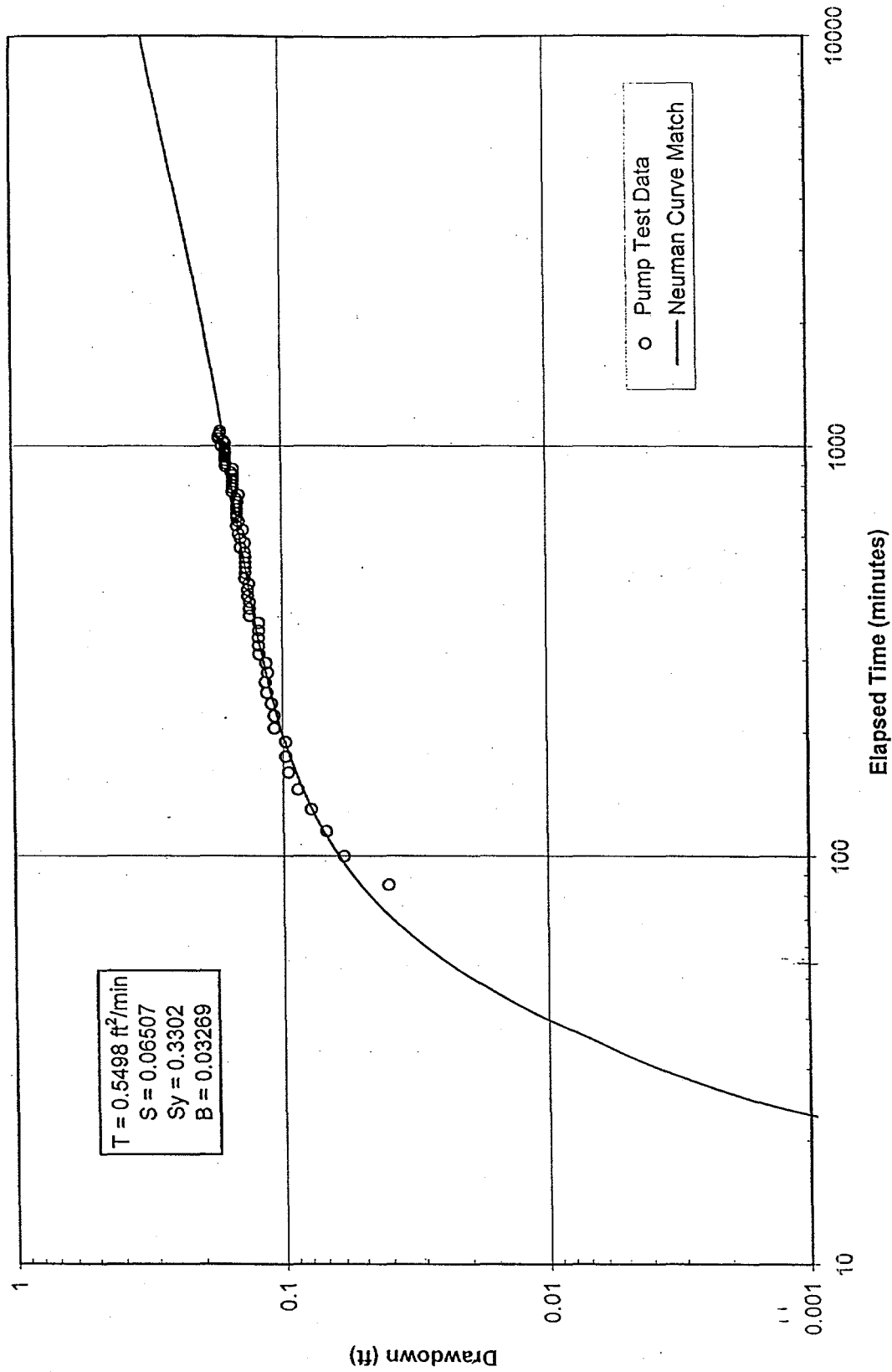

Figure 55

TNX-11D Time-Drawdown Data Versus Neuman Curve

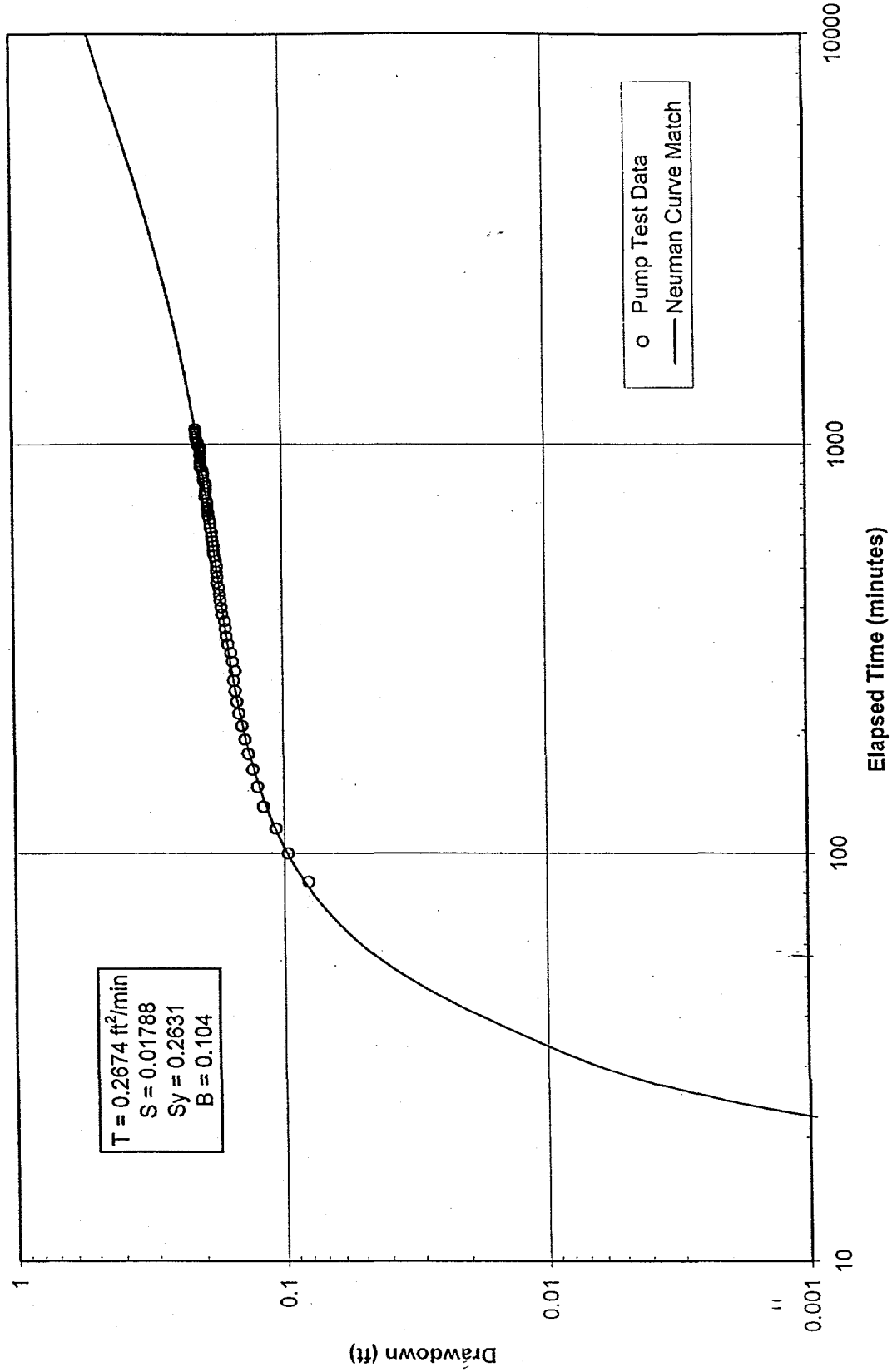

Figure 56

TGSC-1Z Time-Drawdown Data Versus Neuman Curve

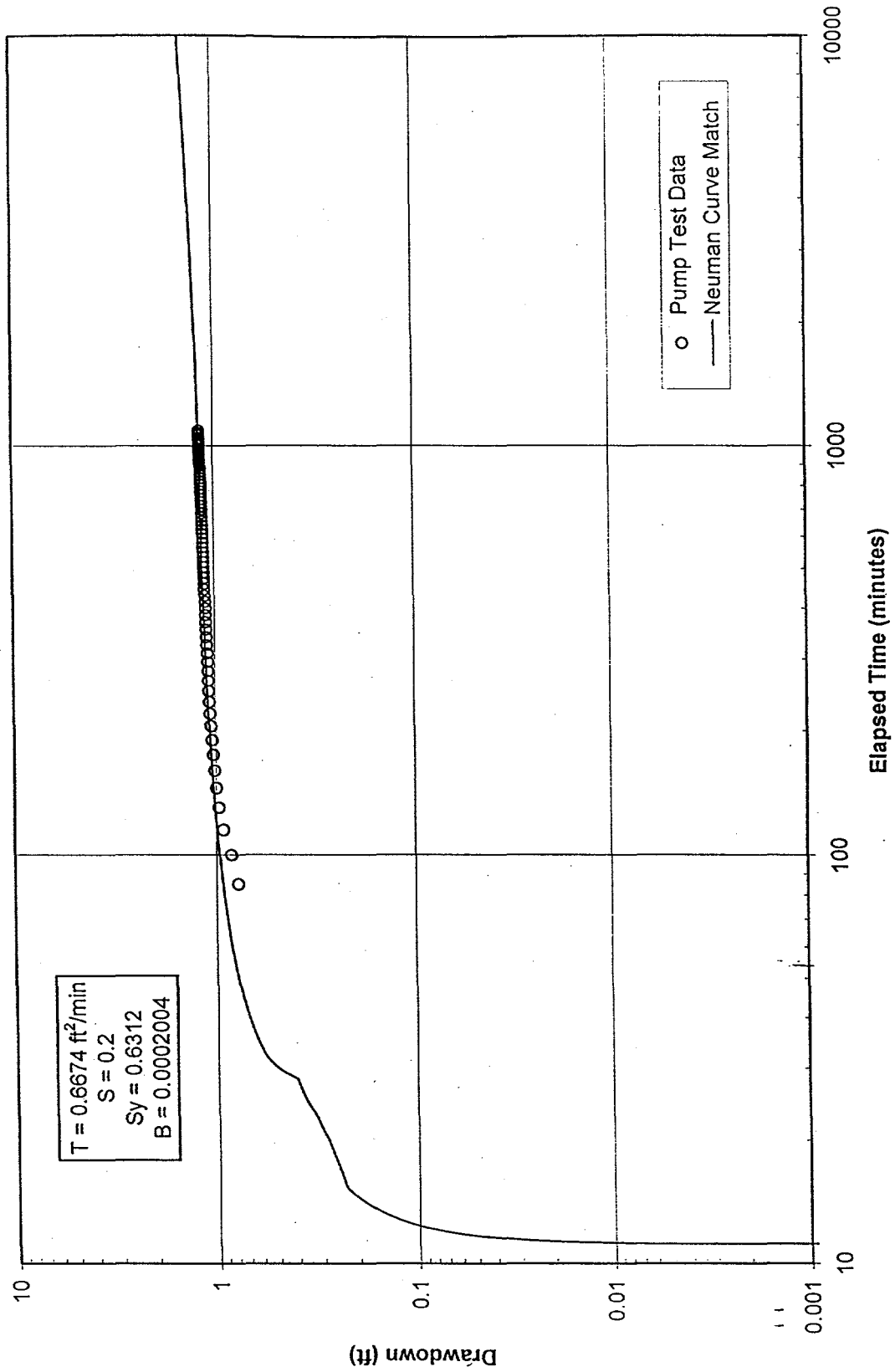

Figure 57

TSGC-1 / Savannah River Hydraulic Response

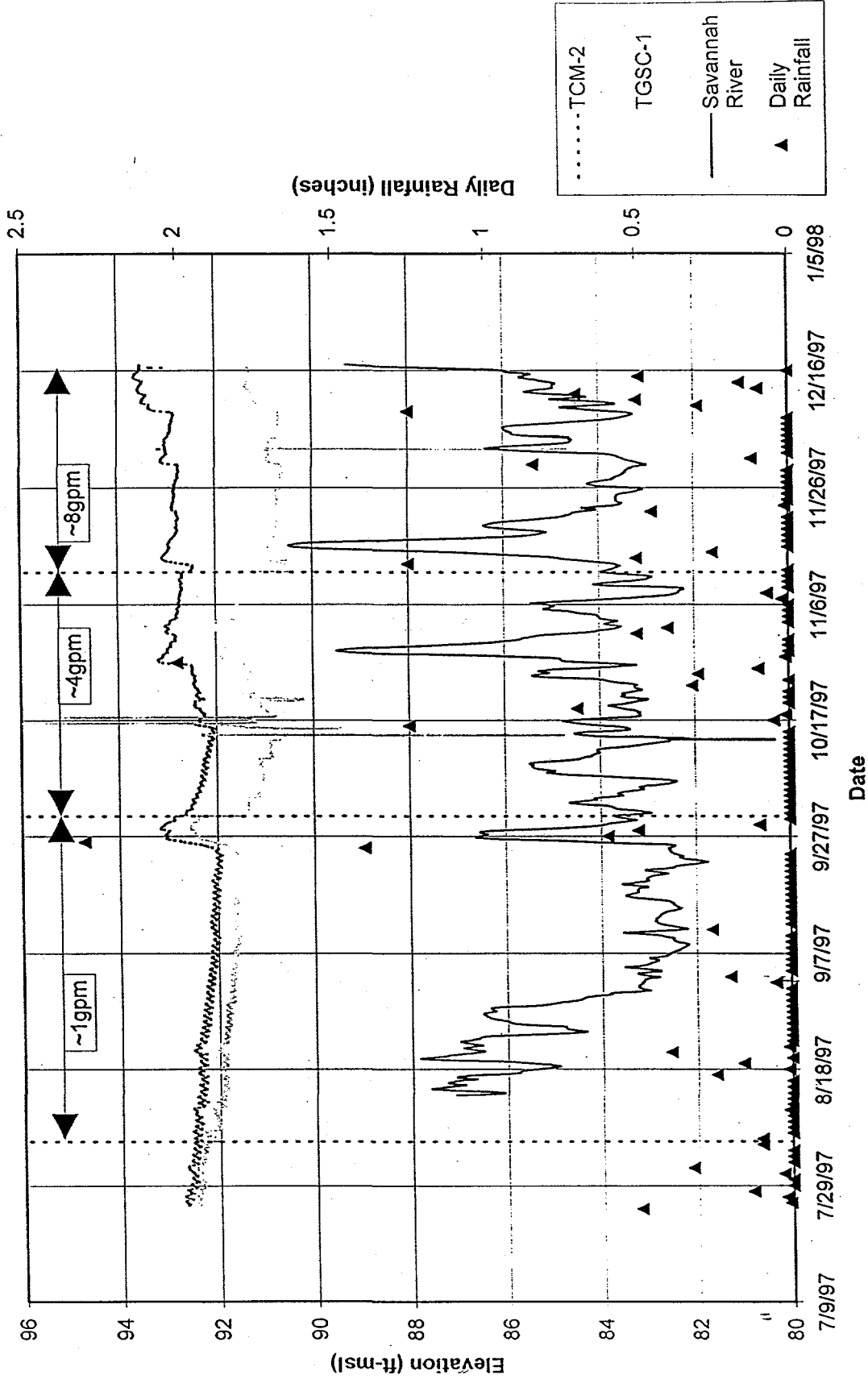

Figure 58

TGSC-1 / Savannah River Head Difference

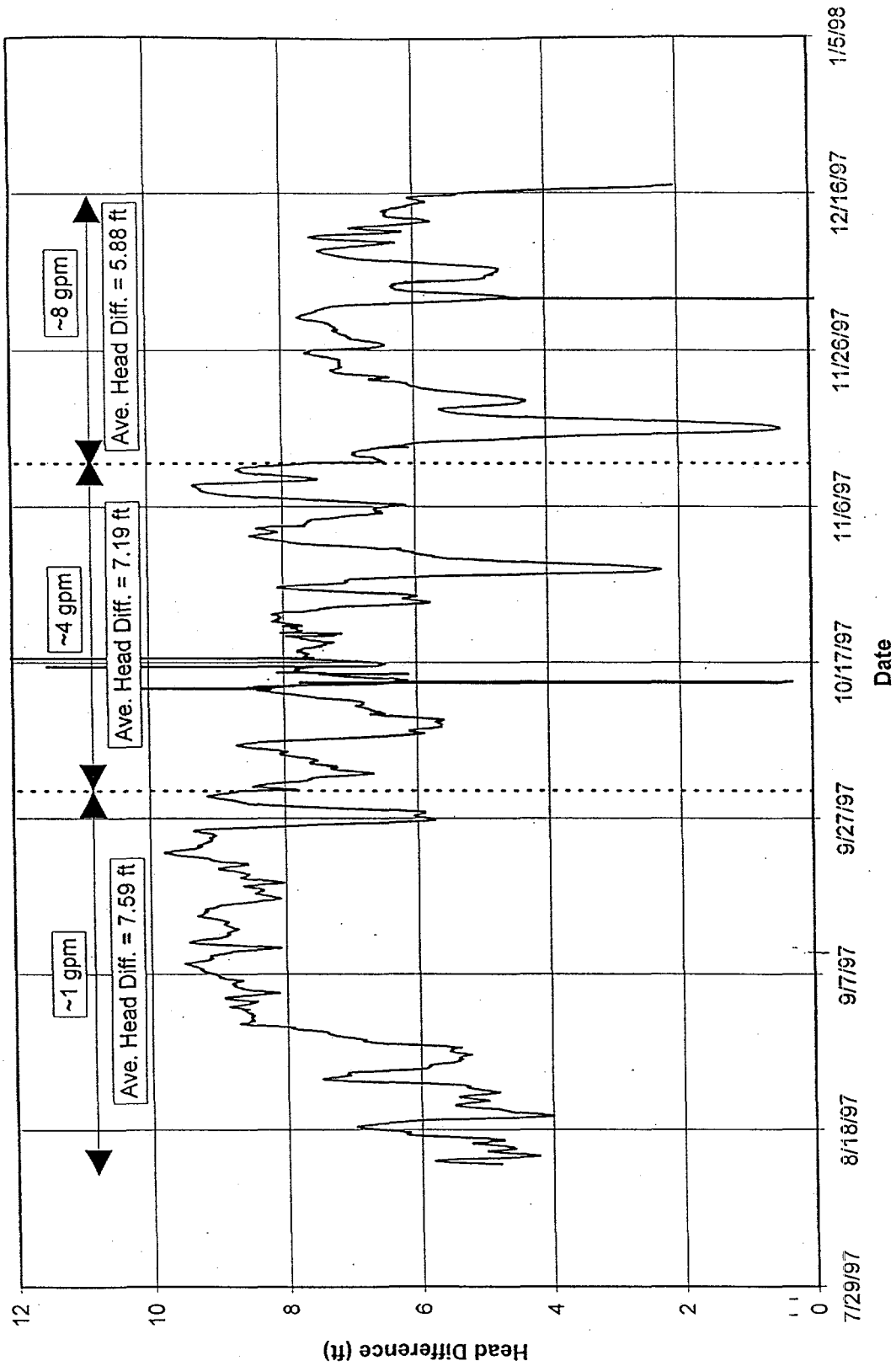

Figure 59

1997 TCE Profile
Along Line of Wells TNX-8D through TNX-12D (~E16170)

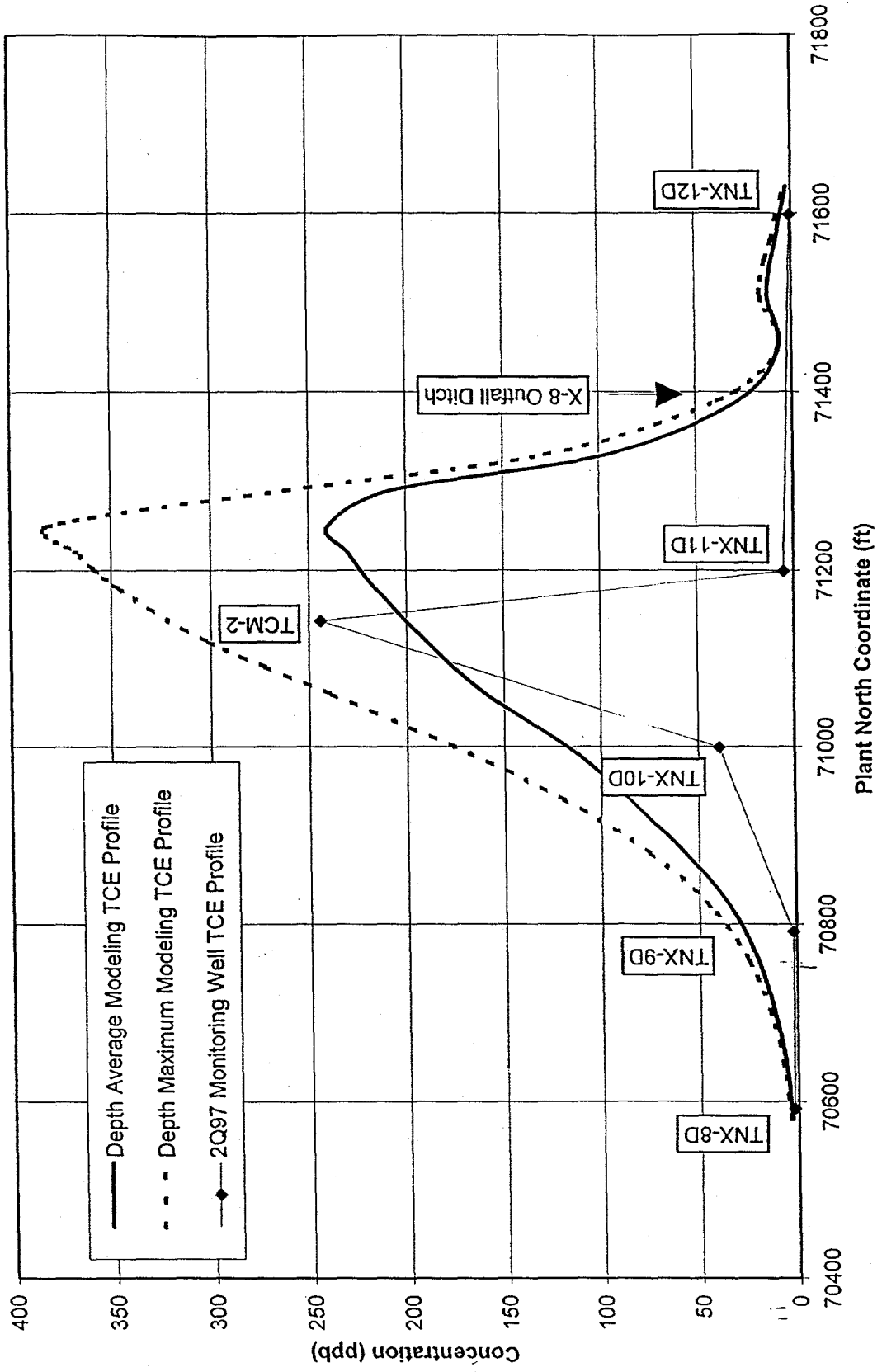
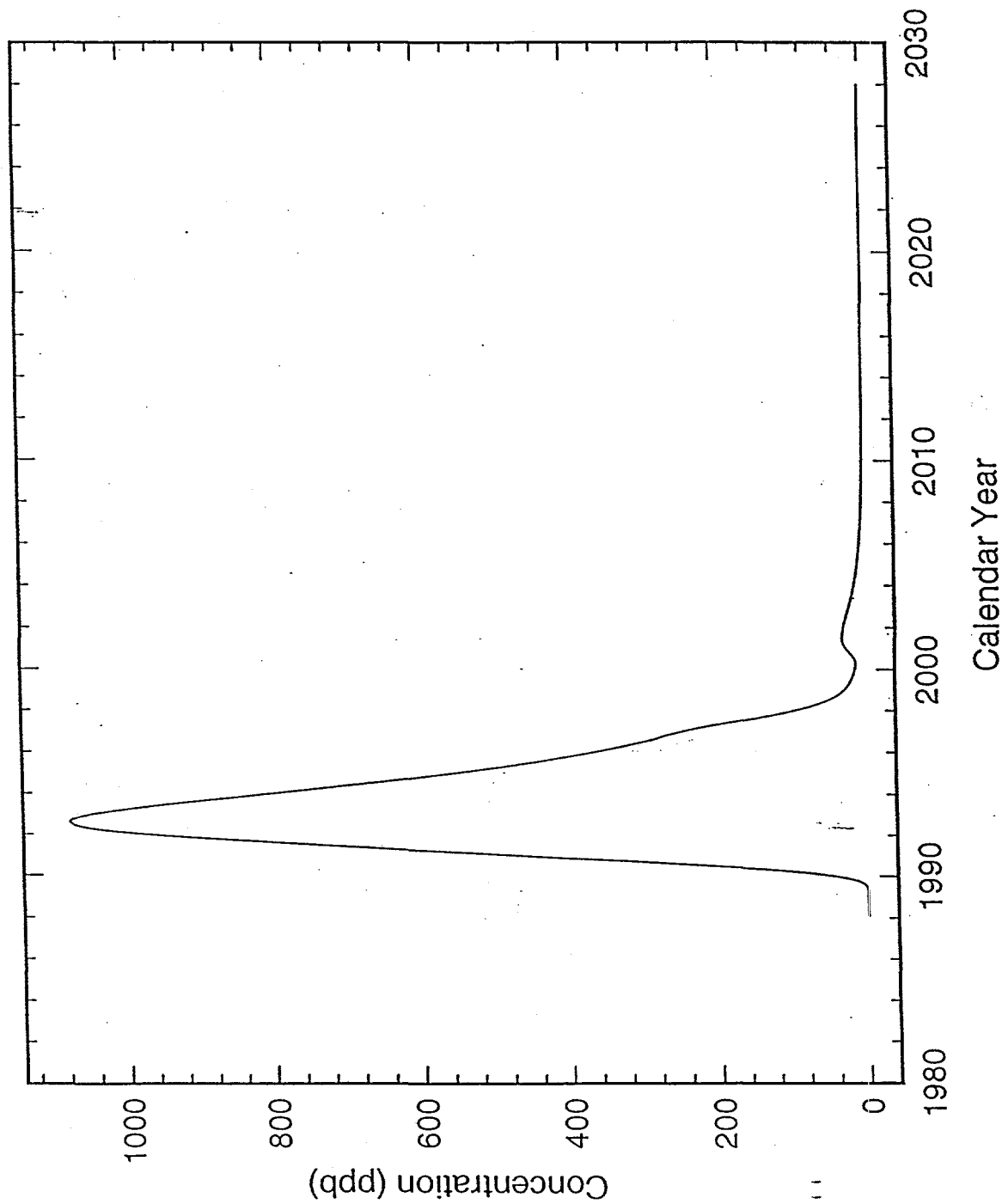

Figure 60
Modeled Average TCE Concentration Over Time - At N71250, E16170



APPENDIX A

TNX GEOSIPHON CELL (TGSC-1)

AS-BUILTS

INDEX OF AS BUILT DRAWINGS

TNX GEO SIPHON CELL

DRAWING NO.	VIEW	DESCRIPTION
TSGC-1-M-1	MATERIALS OF CONSTRUCTION	Description of materials
TSGC-1-S-1	ELEVATION VIEW LOOKING EAST	Geo Siphon Cell Exterior View
TSGC-1-S-2	REINFORCING AND STRUCTURAL STEEL	Details
TSGC-1-S-3	SECTION A-A, B-B, AND C-C	Lateral Bracing @ 20'-2", 17'-10", and 14'-6" from Bottom
	SECTION D-D	Lateral Bracing @ 11'-10" from Bottom
TSGC-1-S-4	SECTION E-E AND F-F	Lateral Bracing @ 3'-2" and 9'-6" from Bottom
	SECTION G-G	Bottom Plate
TSGC-1-W-1	ELEVATION VIEW LOOKING EAST	Well Packing Material
TSGC-1-W-2	ELEVATION VIEW LOOKING NORTH	Well Casing, Screen and Sampling Tubes
TSGC-1-W-3	ELEVATION VIEW LOOKING NORTH	Sampling Tube and Monitoring Well Details
	TABLE 1	Well Elevations and Coordinates
TSGC-1-W-4	ELEVATION VIEW LOOKING NORTH	Above Grade Details
	PLAN VIEW	Above Grade Details

MATERIALS OF CONSTRUCTION

EXTERIOR GEOTEXTILE

GEONET WITH GEOTEXTILE FLUID SYSTEMS (FSI) TEX-NET® TN3002/1125 (THIS CONSISTS OF FSI POLY-NET® PN3000 (A HIGH DENSITY POLYETHYLENE (HDPE) GEONET) WITH TREVIRA® SPUNDBOND TYPE 011/250 (A NONWOVEN NEEDLE PUNCHED POLYESTER GEOTEXTILE FABRIC) HEAT-LAMINATED TO BOTH SIDES OF THE OF FSI POLY-NET® PN3000)

HIGH DENSITY POLYETHYLENE MEMBRANE

POLY-FLEX, INC. 80 MIL THICK SMOOTH HIGH DENSITY POLYETHYLENE (HDPE) GEOMEMBRANE SHEET

WELL SCREEN AND CASING

JOHNSON SCREENS™ -12 INCH DIAMETER PIPE SIZE, 10-SLOT, 316L STAINLESS STEEL VEE-WIRE SCREEN WITH A 316L STAINLESS STEEL BOTTOM PLATE

JOHNSON SCREENS™ -12 INCH DIAMETER, SCHEDULE 10, 316L STAINLESS STEEL CASING, AND A 12 INCH DIAMETER, 316L STAINLESS STEEL LOCKING CAP

JOHNSON SCREENS™ -1 FOOT LONG, 2 INCH DIAMETER (MINIMUM 2 INCH CLEAR INSIDE DIAMETER) PIPE SIZE, 10-SLOT, SCHEDULE 40 PVC, FLUSH THREADED, VEE-WIRE SCREEN WITH A BOTTOM PLUG

JOHNSON SCREENS™ -15 FEET OF 2 INCH DIAMETER, SCHEDULE 40 PVC, FLUSH THREADED CASING, AND A 2 INCH DIAMETER CAP

IRON FILINGS

PEERLESS™ METAL POWDERS & ABRASIVE -8 TO +50 MESH (0.25 TO 2.0 MM), OIL FREE (KILN FIRED) GRANULAR CAST IRON, IRON AGGREGATE TYPE ETI 8/50.

SIEVE ANALYSIS 5 MINUTE ROTAP & PASSING ACCUMULATIVE

SIEVE SIZE	MINIMUM	MAXIMUM	TYPICAL
# 4 4.75	-	100	100
8 2.36	95	100	99.5
16 1.18	75	90	87
30 0.60	30	50	32
50 0.30	2	10	4
100 0.15	0	5	0.5

MINIMUM SURFACE AREA 1.1 SQUARE METERS PER GRAM
 MINIMUM TOTAL IRON CONTENT OF 80%-(TYPICAL IS ABOVE 90%)
 NO DETECTABLE ORGANIC CONSTITUENTS PRESENT IN THE FINISHED PRODUCT
 WEIGHT PER CUBIC FOOT TYPICAL LOOSE FILLED 160#
 SPECIFIC GRAVITY (PARTICLE DENSITY) 6.8-6.9 GRAMS/CC

BENTONITE

BAROID® BENTONITE- (3/8 TO 1/2 INCH UNCOATED BENTONITE PELLETS)

LEAN FILL

CONTROLLED LOW STRENGTH MATERIAL (CLSM) PLACED ON TOP OF THE BENTONITE SEAL AND USED TO BRING THE HOLE TO GRADE. TYPICAL LEAN FILL CONSISTS OF THE FOLLOWING PER CUBIC YARD: 50 LBS OF CEMENT, 66 GALLONS OF POTABLE WATER, 2215 LBS OF SAND, AND 600 LBS OF POZZOLAN.

United States Department of Energy Westinghouse Savannah River Company Savannah River Technology Center Environmental Science and Technology		
Location: Savannah River Site (TNX Flood Plain)		
Project: TNX Geo Siphon Cell	P.O. Q800220K	
TNX Geo Siphon Cell As Built Drawing		
Drawn By: F. C. Sappington	Date: 8/4/94	Rev. No.: 0
Drawing No. TGSC-1-M-1	Prepared: <i>[Signature]</i>	Checked: <i>[Signature]</i>

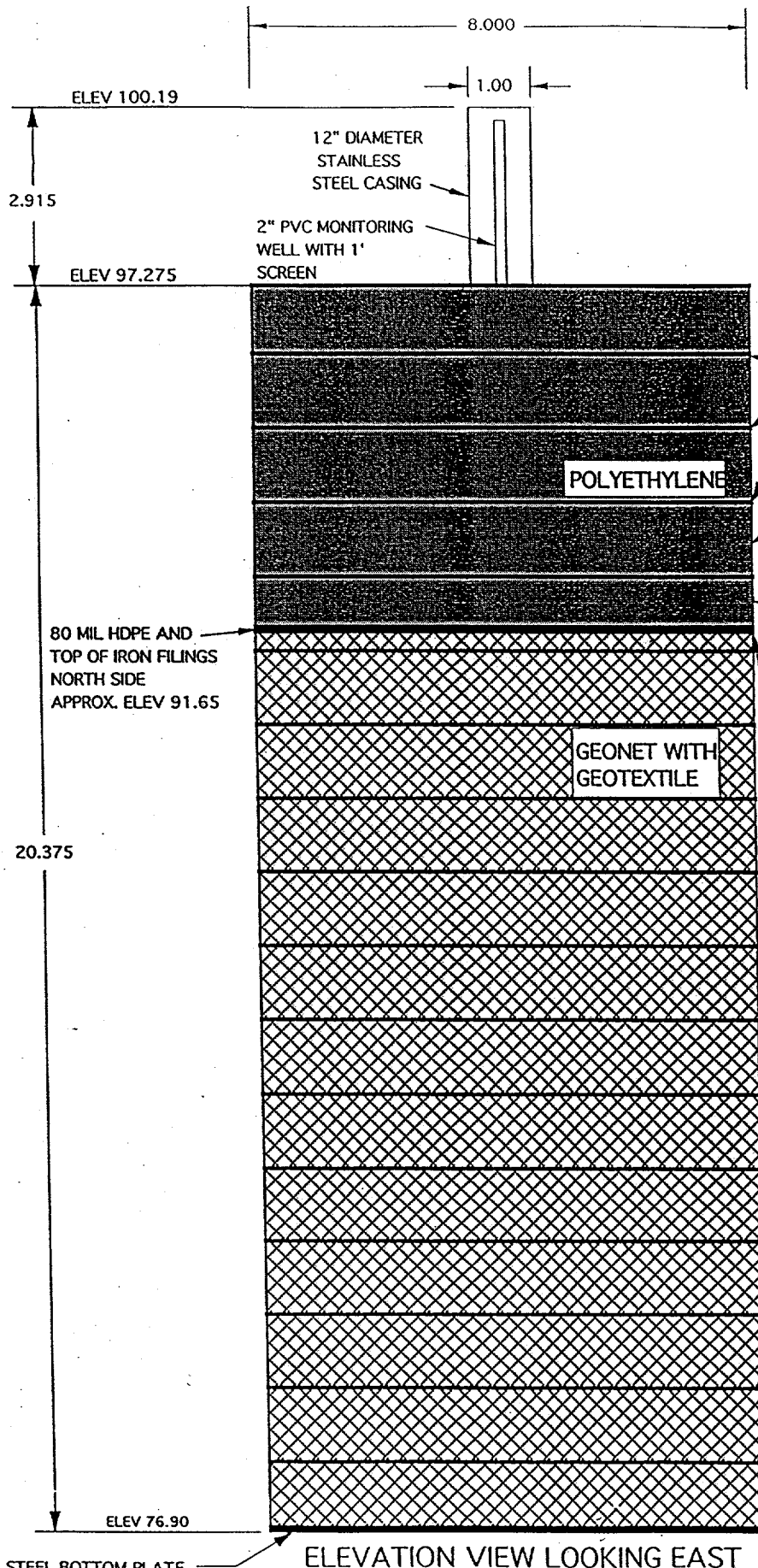

- NOTES:
- 1 ALL DIMENSIONS IN FT-DEC.
 - 2 IN ADDITION TO THE STEEL BANDING THE GEONET/GEOTEXTILE IS WIRE TIED TO STEEL REINFORCING CAGE

ELEVATION VIEW LOOKING EAST
GEO SIPHON CELL EXTERIOR VIEW

United States Department of Energy Westinghouse Savannah River Company Savannah River Technology Center Environmental Science and Technology		
Location: Savannah River Site (TNX Flood Plain)		
Project: TNX Geo Siphon Cell	P.O. Q800220K	
TNX Geo Siphon Cell As Built Drawing		
Drawn By: F. C. Sappington	Date: 8/4/97	Rev. No.: 0
Drawing No. TGSC-1-S-1	Prepared: [Signature]	Checked: [Signature]

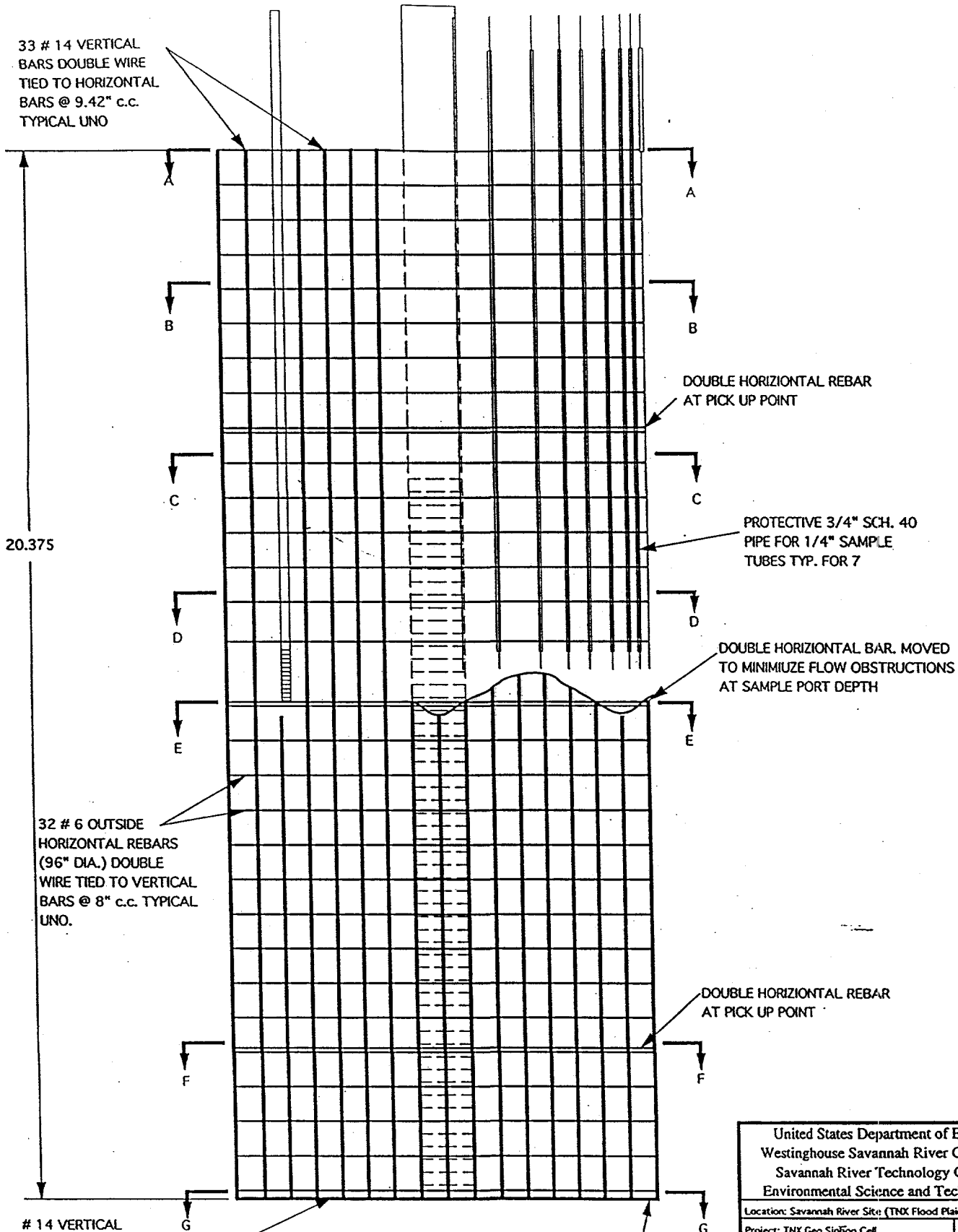

33 # 14 VERTICAL
BARS DOUBLE WIRE
TIED TO HORIZONTAL
BARS @ 9.42" c.c.
TYPICAL UNO

20.375

DOUBLE HORIZONTAL REBAR
AT PICK UP POINT

PROTECTIVE 3/4" SCH. 40
PIPE FOR 1/4" SAMPLE
TUBES TYP. FOR 7

DOUBLE HORIZONTAL BAR, MOVED
TO MINIMUZE FLOW OBSTRUCTIONS
AT SAMPLE PORT DEPTH

32 # 6 OUTSIDE
HORIZONTAL REBARS
(96" DIA.) DOUBLE
WIRE TIED TO VERTICAL
BARS @ 8" c.c. TYPICAL
UNO.

DOUBLE HORIZONTAL REBAR
AT PICK UP POINT

14 VERTICAL
BARS WELDED TO
BOTTOM PLATE
SEE SECTION G-G
DRAWING S-4

1/2" STEEL BOTTOM PLATE
ELEVATION 76.90'

REINFORCING AND STRUCTURAL STEEL DETAILS

United States Department of Energy Westinghouse Savannah River Company Savannah River Technology Center Environmental Science and Technology		
Location: Savannah River Site: (TNX Flood Plain)		
Project: TNX Geo Siphon Cell	P.O. Q800220K	
TNX Geo Siphon Cell As Built Drawing		
Drawn By: F. C. Sappington	Date: 8/4/97	Rev. No.: 0
Drawing No. YGSC-1-S-2	Prepared: <i>[Signature]</i>	Checked: <i>[Signature]</i>

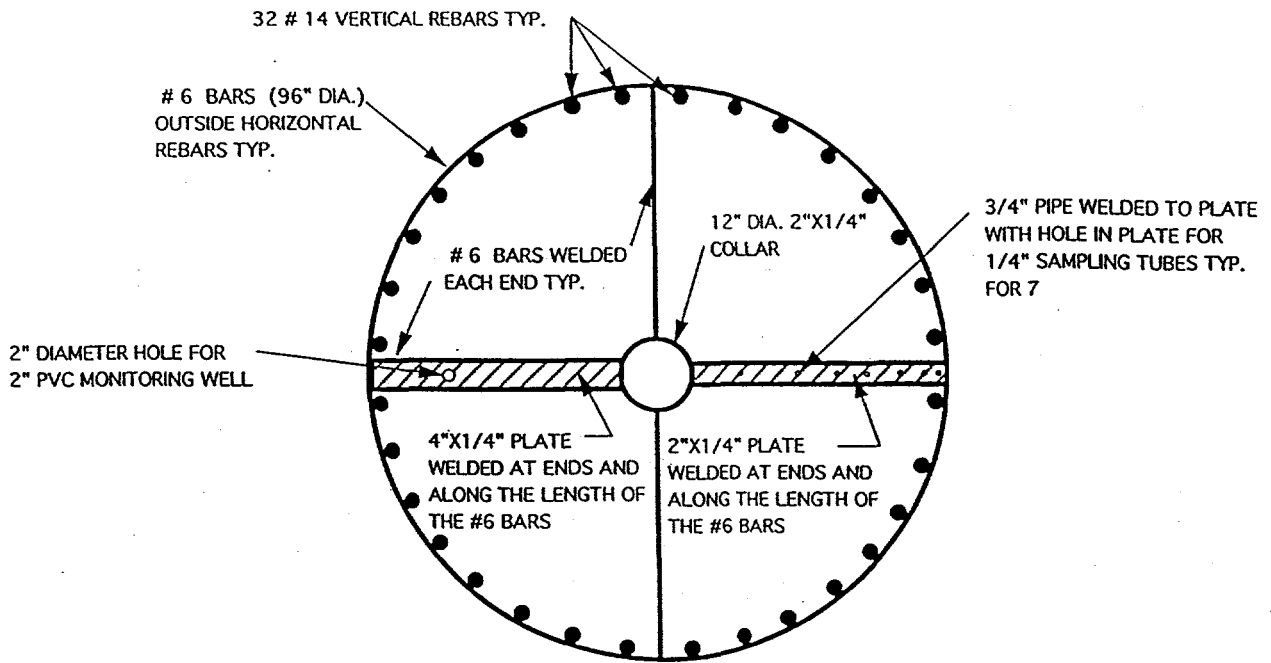

SECTION A-A, B-B, AND C-C

LATERAL BRACING @ 20'-2", 17'-10", AND 14'-6" FROM BOTTOM

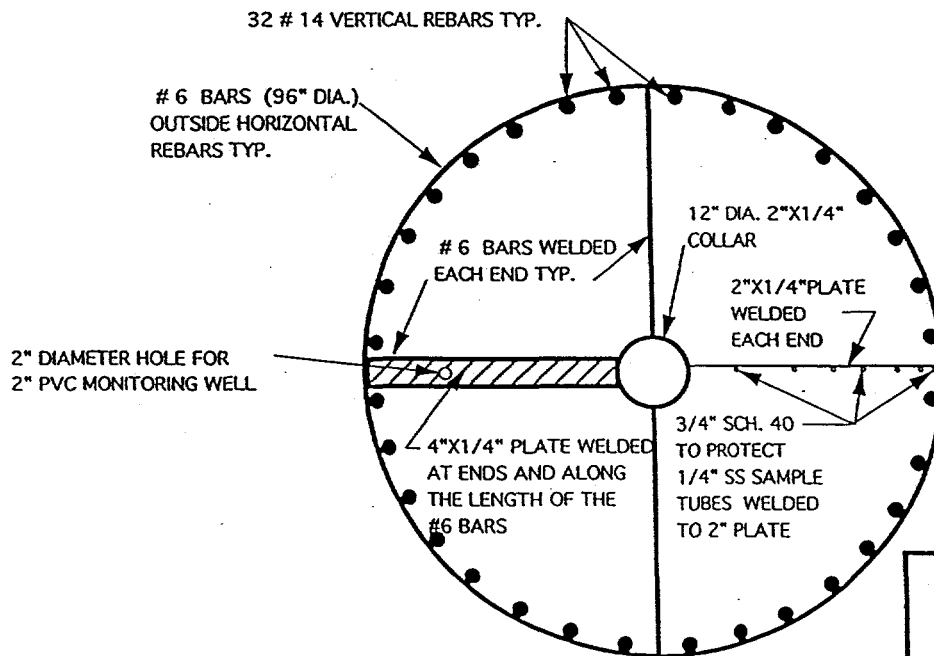

SECTION D-D

LATERAL BRACING @ 14'-10" FROM BOTTOM

United States Department of Energy Westinghouse Savannah River Company Savannah River Technology Center Environmental Science and Technology		
Location: Savannah River Site (TNX Flood Plain)		
Project: TNX Geo Siphon Cell	P.O. 0800220K	
TNX Geo Siphon Cell As Built Drawing		
Drawn By: F. C. Sappington	Date: 8/4/77	Rev. No.: 0
Drawing No. TGSC-1-S-3	Prepared: [Signature]	Checked: [Signature]

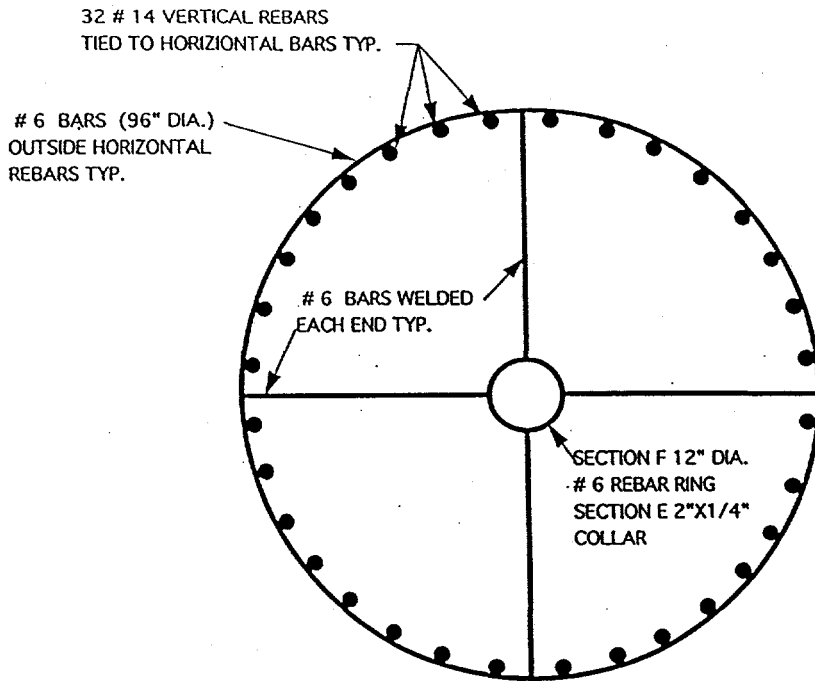

SECTION E-E AND F-F

LATERAL BRACING @ 3'-2" AND 9'-6" FROM BOTTOM

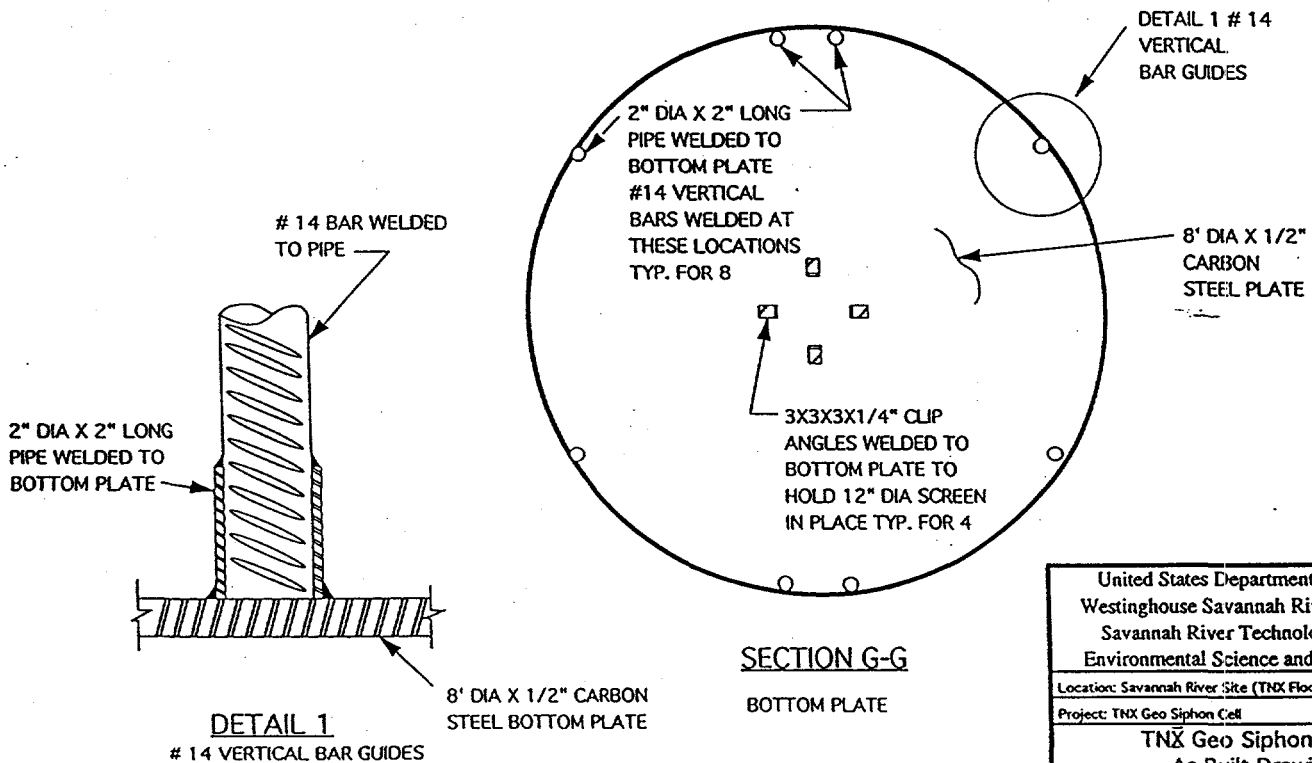

NOTE: ALL OTHER VERTICAL BARS WELDED DIRECTLY TO THE BOTTOM PLATE

United States Department of Energy Westinghouse Savannah River Company Savannah River Technology Center Environmental Science and Technology		
Location: Savannah River Site (TNX Flood Plain)		
Project: TNX Geo Siphon Cell	P.O. Q800220K	
TNX Geo Siphon Cell As Built Drawing		
Drawn By: F. C. Sappington	Date: 8/4/97	Rev. No.: 0
Drawing No. TGSC-1-S-4	Prepared: <i>[Signature]</i>	Checked: <i>[Signature]</i>

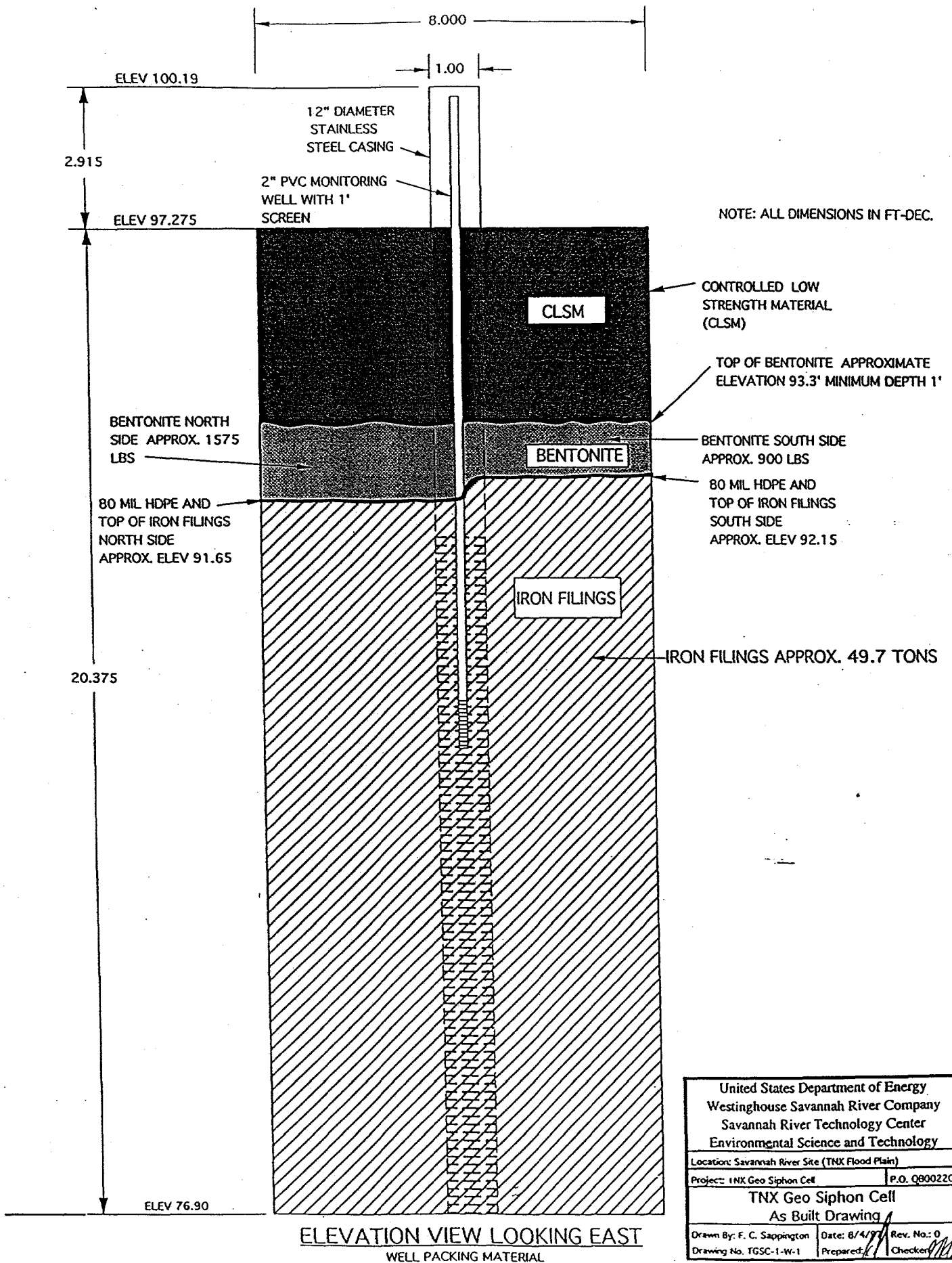

United States Department of Energy Westinghouse Savannah River Company Savannah River Technology Center Environmental Science and Technology		
Location: Savannah River Site (TNX Flood Plain)		
Project: INX Geo Siphon Cell	P.O. Q600220K	
TNX Geo Siphon Cell As Built Drawing		
Drawn By: F. C. Sappington	Date: 8/4/97	Rev. No.: 0
Drawing No. TGSC-1-W-1	Prepared: <i>[Signature]</i>	Checked: <i>[Signature]</i>

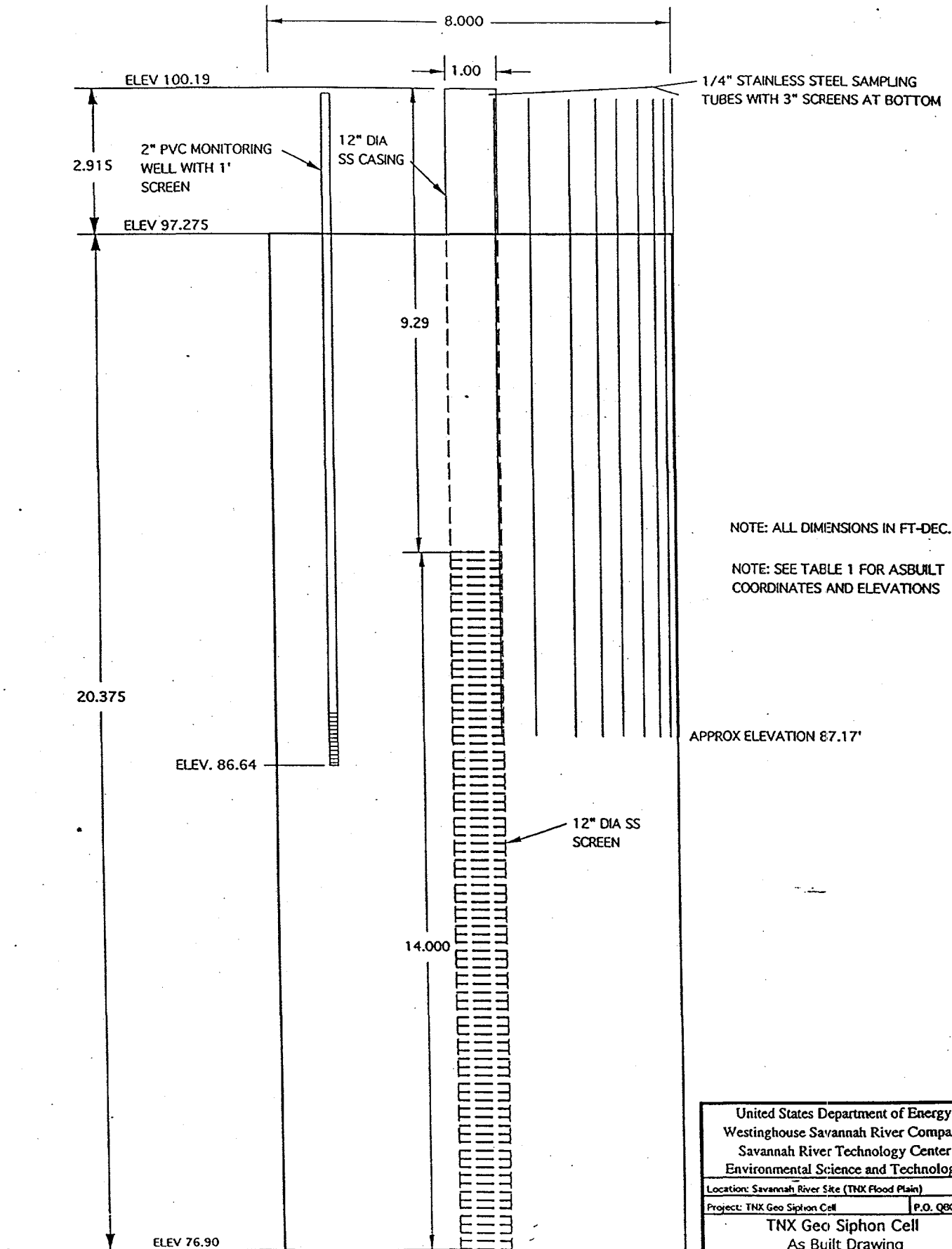

NOTE: ALL DIMENSIONS IN FT-DEC.

NOTE: SEE TABLE 1 FOR ASBUILT COORDINATES AND ELEVATIONS

APPROX ELEVATION 87.17'

ELEVATION VIEW LOOKING NORTH
WELL CASING, SCREEN AND SAMPLING TUBES

United States Department of Energy		
Westinghouse Savannah River Company		
Savannah River Technology Center		
Environmental Science and Technology		
Location: Savannah River Site (TNX Flood Plain)		
Project: TNX Geo Siphon Cell	P.O. Q800220K	
TNX Geo Siphon Cell		
As Built Drawing		
Drawn By: F. C. Sappington	Date: 8/4/87	Rev. No.: 0
Drawing No. TGSC-1-W-2	Prepared: <i>[Signature]</i>	Checked: <i>[Signature]</i>

E
4
V
1

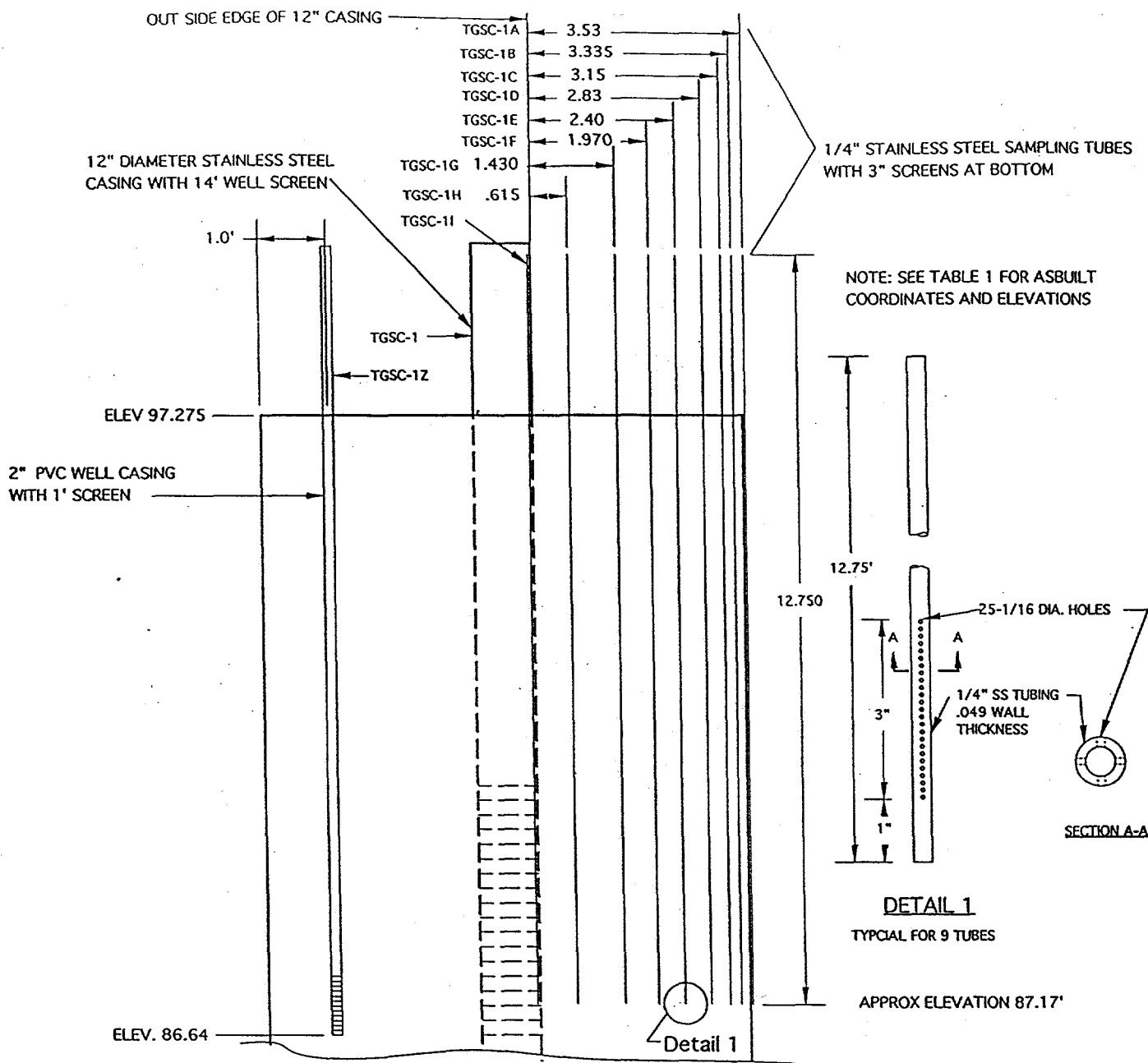

ELEVATION VIEW LOOKING NORTH

SAMPLING TUBE AND MONITORING WELL DETAILS

DESCRIPTION	TOP ELEV.	LENGTH	BOTTOM ELEV.	LATITUDE	LONGITUDE
TOP CONCRETE	97.64	0.67	96.97	33.20949	81.7623299
GROUND ELEV.	97.117	NA	NA	33.2094796	81.7623477
TGSC-1A	99.939	12.75	87.19	33.2094962	81.7623168
TGSC-1B	99.932	12.75	87.18	33.2094958	81.7623173
TGSC-1C	99.923	12.75	87.17	33.2094955	81.762318
TGSC-1D	99.919	12.75	87.17	33.2094951	81.7623187
TGSC-1E	99.917	12.75	87.17	33.2094946	81.7623201
TGSC-1F	99.907	12.75	87.16	33.209494	81.7623212
TGSC-1G	99.882	12.75	87.13	33.2094933	81.7623229
TGSC-1H	99.842	12.75	87.09	33.2094922	81.7623252
TGSC-1I	99.845	12.75	87.10	33.2094911	81.7623264
CL 12" CASING W/O COVER	100.194	23.25	76.94	33.2094908	81.7623281
CL TGSC-1Z 2" PVC W/O CAP	100.06	13.42	86.64	33.2094866	81.7623365

TABLE 1 WELL ELEVATIONS AND COORDINATES

United States Department of Energy Westinghouse Savannah River Company Savannah River Technology Center Environmental Science and Technology	
Location: Savannah River Site (TNX Flood Plain)	
Project: TNX Geo Siphon Cell	P.O. Q800220K
TNX Geo Siphon Cell As Built Drawing	
Drawn By: F. C. Sappington	Date: 8/4/93
Drawing No. TGSC-1-W-3	Rev. No.: 0 Prepared: [Signature] Checker: [Signature]

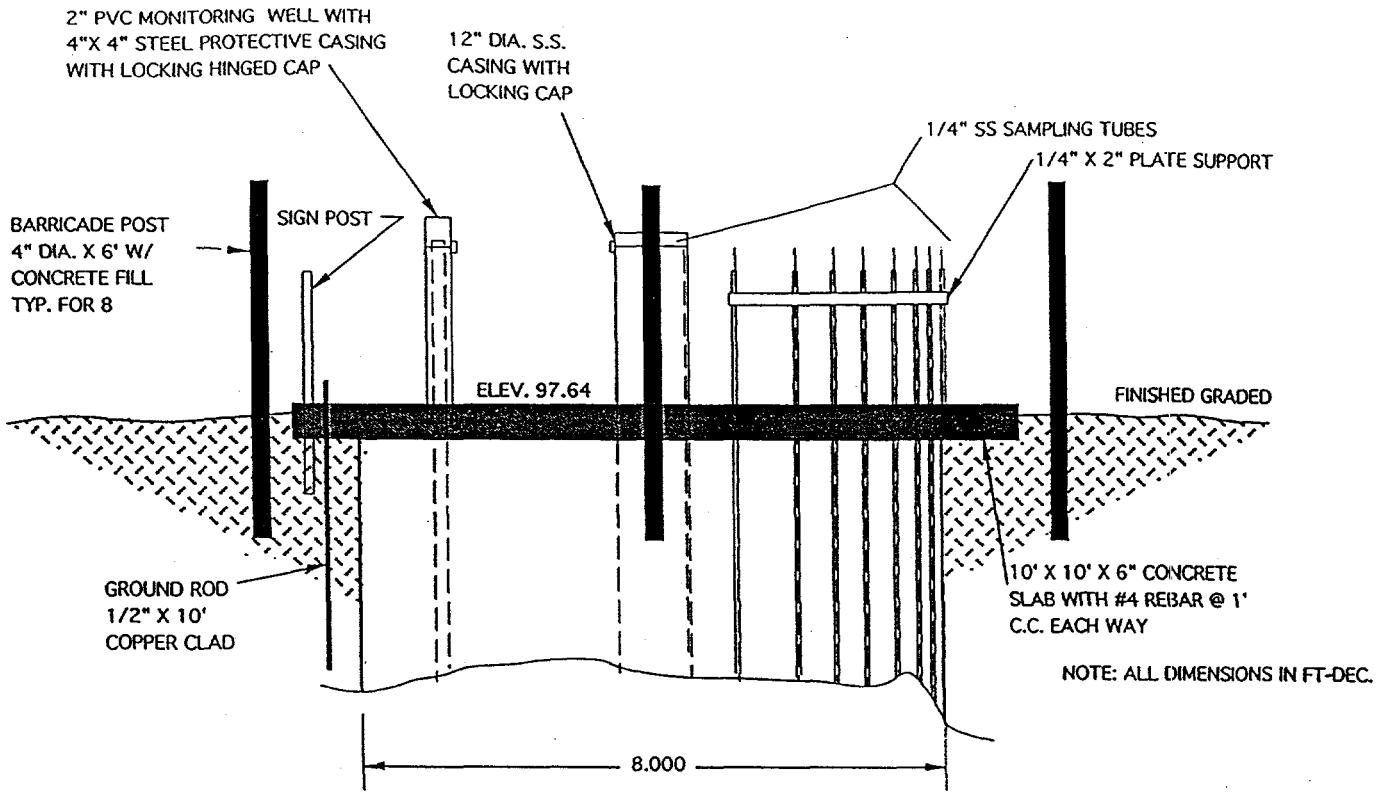

ELEVATION VIEW LOOKING NORTH

ABOVE GRADE DETAILS

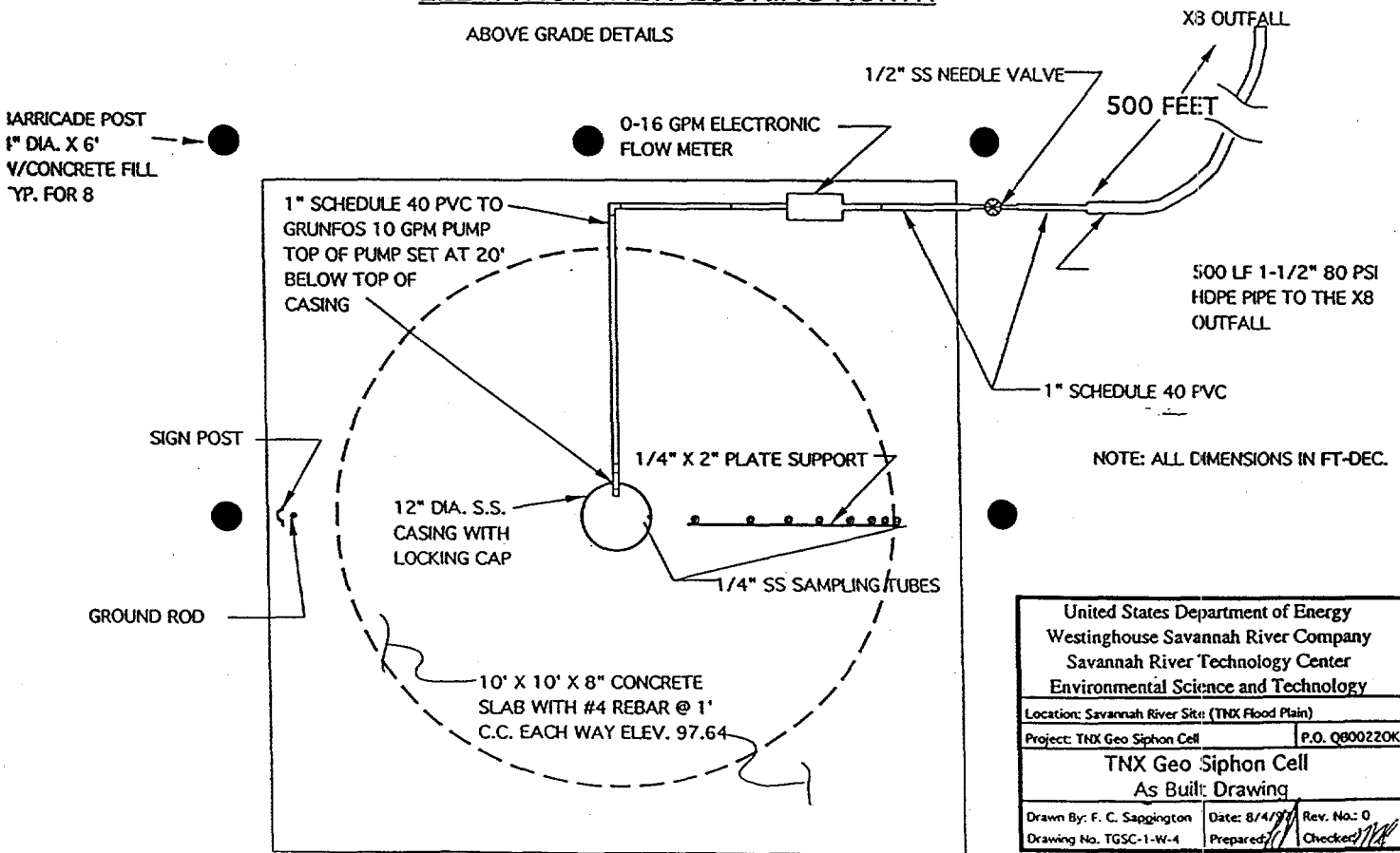

PLAN VIEW

ABOVE GRADE DETAILS

United States Department of Energy Westinghouse Savannah River Company Savannah River Technology Center Environmental Science and Technology		
Location: Savannah River Site (TNX Flood Plain)		
Project: TNX Geo Siphon Cell P.O. Q800220K		
TNX Geo Siphon Cell As Built: Drawing		
Drawn By: F. C. Sappington	Date: 8/4/97	Rev. No.: 0
Drawing No. TGSC-1-W-4	Prepared: [Signature]	Checked: [Signature]

APPENDIX B**ANALYTICAL DATA SUMMARY TABLES**

- Appendix B-1, 1 gpm Testing - CVOC Data Summary
- Appendix B-2, 1 gpm Steady State CVOC Data Summary - ADS Laboratory
- Appendix B-3, 1 gpm Steady State Inorganic Data Summary - ADS Laboratory
- Appendix B-4, 1 gpm Testing - Field Data Summary
- Appendix B-5, 4 gpm Testing - CVOC Data Summary
- Appendix B-6, 4 gpm Steady State CVOC Data Summary - ADS Laboratory
- Appendix B-7, 4 gpm Steady State Inorganic Data Summary - ADS Laboratory
- Appendix B-8, 4 gpm Testing - Field Data Summary
- Appendix B-9, 8 gpm Testing - CVOC Data Summary
- Appendix B-10, 8 gpm Steady State CVOC Data Summary - ADS Laboratory
- Appendix B-11, 8 gpm Steady State CVOC Data Summary - GEL Laboratory
- Appendix B-12, 8 gpm Steady State Inorganic Data Summary - ADS Laboratory
- Appendix B-13, 8 gpm Steady State Inorganic Data Summary - GEL Laboratory
- Appendix B-14, 8 gpm Testing - Field Data Summary
- Appendix B-15, Steady State CVOC Data Summary
- Appendix B-16, Steady State Inorganic Data Summary
- Appendix B-17, Steady State Field Data Summary

1 ppm Testing - CVOC Data Summary

Sample Location	Distance into Cell (ft)	Flow (gpm)	7/24/97		8/13/97		8/19/97		8/26/97		9/2/97		9/30/97		ADS
			EBS	ERT	EBS	ERT	EBS	ERT	EBS	ERT	EBS	ERT	EBS	ERT	
TCM-2	0 trichloroethylene	NA	NA	NA	NA	NA	NA	NA	NA	NA	NA	NA	NA	NA	NA
TGSC-1A	0 trichloroethylene	NA	NA	NA	NA	NA	NA	NA	NA	NA	NA	NA	NA	NA	156.0
TGSC-1B	0.14 trichloroethylene	ND	<4	29.7	15.2	42.4	22.1	41.0	28.1	40.9	17.3	40.4	44.7	27.0	27.0
TGSC-1C	0.32 trichloroethylene	ND	<4	ND	<4	ND	<4	ND	<4	ND	<4	ND	3.0	8.1	5.4
TGSC-1D	0.64 trichloroethylene	ND	<4	ND	<4	ND	<4	ND	<4	ND	<4	ND	ND	ND	<1
TGSC-1E	1.07 trichloroethylene	ND	<4	ND	<4	ND	<4	ND	<4	ND	<4	ND	ND	ND	<1
TGSC-1F	1.5 trichloroethylene	ND	<4	ND	<4	ND	<4	ND	<4	ND	<4	ND	ND	ND	<1
TGSC-1G	2.04 trichloroethylene	ND	<4	ND	<4	ND	<4	ND	<4	ND	<4	ND	ND	ND	<1
TGSC-1H	2.86 trichloroethylene	ND	<4	ND	<4	ND	<4	ND	<4	ND	<4	ND	ND	ND	<1
TGSC-1I	3.47 trichloroethylene	0.4	<4	2.0	<4	ND	<4	1.3	<4	0.3	NA	ND	ND	ND	<1
TGSC-1S	trichloroethylene	NA	NA	NA	NA	NA	NA	1.0	<4	0.2	NA	ND	0.2	<1	<1
TGSC-X8	trichloroethylene	NA	NA	1.9	<4	ND	<4	0.7	<4	0.2	<4	ND	ND	<1	<1
TCM-2	0 cis-1,2-dichloroethylene	NA	NA	NA	NA	NA	NA	NA	NA	NA	NA	NA	NA	NA	NA
TGSC-1A	0 cis-1,2-dichloroethylene	NA	NA	NA	NA	NA	NA	NA	NA	NA	NA	NA	NA	NA	22.0
TGSC-1B	0.14 cis-1,2-dichloroethylene	ND	<4	16.1	18.1	13.7	35.8	32.5	8.7	11.7	8.9	23.9	<10	<10	3.5
TGSC-1C	0.32 cis-1,2-dichloroethylene	ND	<4	ND	<4	ND	<4	ND	<4	ND	<4	ND	<4	ND	3.3
TGSC-1D	0.64 cis-1,2-dichloroethylene	ND	<4	ND	<4	ND	<4	ND	<4	ND	<4	ND	ND	ND	2.6
TGSC-1E	1.07 cis-1,2-dichloroethylene	ND	<4	ND	<4	ND	<4	ND	<4	ND	<4	ND	ND	ND	1.1
TGSC-1F	1.5 cis-1,2-dichloroethylene	ND	<4	ND	<4	ND	<4	ND	<4	ND	<4	ND	ND	ND	<1
TGSC-1G	2.04 cis-1,2-dichloroethylene	ND	<4	ND	<4	ND	<4	ND	<4	ND	<4	ND	ND	ND	<1
TGSC-1H	2.86 cis-1,2-dichloroethylene	ND	<4	ND	<4	ND	<4	ND	<4	ND	<4	ND	ND	ND	<1
TGSC-1I	3.47 cis-1,2-dichloroethylene	ND	<4	ND	<4	ND	<4	ND	<4	ND	<4	ND	ND	ND	<1
TGSC-1S	cis-1,2-dichloroethylene	NA	NA	NA	NA	NA	NA	NA	NA	NA	NA	NA	NA	NA	<1
TGSC-X8	cis-1,2-dichloroethylene	NA	NA	NA	NA	NA	NA	NA	NA	NA	NA	NA	NA	NA	<1
TCM-2	0 Carbon Tetrachloride	NA	NA	NA	NA	NA	NA	NA	NA	NA	NA	NA	NA	NA	NA
TGSC-1A	0 Carbon Tetrachloride	NA	NA	NA	NA	NA	NA	NA	NA	NA	NA	NA	NA	NA	20.0
TGSC-1B	0.14 Carbon Tetrachloride	ND	<4	ND	<4	ND	<4	ND	<4	ND	<4	ND	ND	ND	<1
TGSC-1C	0.32 Carbon Tetrachloride	ND	<4	ND	<4	ND	<4	ND	<4	ND	<4	ND	ND	ND	<1
TGSC-1D	0.64 Carbon Tetrachloride	ND	<4	ND	<4	ND	<4	ND	<4	ND	<4	ND	ND	ND	<1
TGSC-1E	1.07 Carbon Tetrachloride	ND	<4	ND	<4	ND	<4	ND	<4	ND	<4	ND	ND	ND	<1
TGSC-1F	1.5 Carbon Tetrachloride	ND	<4	ND	<4	ND	<4	ND	<4	ND	<4	ND	ND	ND	<1
TGSC-1G	2.04 Carbon Tetrachloride	ND	<4	ND	<4	ND	<4	ND	<4	ND	<4	ND	ND	ND	<1
TGSC-1H	2.86 Carbon Tetrachloride	ND	<4	ND	<4	ND	<4	ND	<4	ND	<4	ND	ND	ND	<1
TGSC-1I	3.47 Carbon Tetrachloride	0.1	<4	0.1	<4	ND	<4	ND	<4	ND	<4	ND	ND	ND	<1
TGSC-1S	Carbon Tetrachloride	NA	NA	NA	NA	NA	NA	NA	NA	NA	NA	NA	NA	NA	<1
TGSC-X8	Carbon Tetrachloride	NA	NA	NA	NA	NA	NA	NA	NA	NA	NA	NA	NA	NA	<1
TCM-2	0 chloroform	NA	NA	NA	NA	NA	NA	NA	NA	NA	NA	NA	NA	NA	NA
TGSC-1A	0 chloroform	NA	NA	NA	NA	NA	NA	NA	NA	NA	NA	NA	NA	NA	NA
TGSC-1B	0.14 chloroform	ND	<2	2.9	<2	ND	<2	2.0	<2	1.1	<4	0.4	0.4	<1	2.2
TGSC-1C	0.32 chloroform	ND	<2	ND	<2	ND	<2	ND	<2	ND	<2	ND	ND	ND	<1
TGSC-1D	0.64 chloroform	ND	<2	ND	<2	ND	<2	ND	<2	ND	<2	ND	ND	ND	<1
TGSC-1E	1.07 chloroform	ND	<2	ND	<2	ND	<2	ND	<2	ND	<2	ND	ND	ND	<1
TGSC-1F	1.5 chloroform	ND	<2	ND	<2	ND	<2	ND	<2	ND	<2	ND	ND	ND	<1
TGSC-1G	2.04 chloroform	ND	<2	ND	<2	ND	<2	ND	<2	ND	<2	ND	ND	ND	<1
TGSC-1H	2.86 chloroform	ND	<2	ND	<2	ND	<2	ND	<2	ND	<2	ND	ND	ND	<1
TGSC-1I	3.47 chloroform	ND	<2	ND	<2	ND	<2	ND	<2	ND	<2	ND	ND	ND	<1
TGSC-1S	chloroform	NA	NA	NA	NA	NA	NA	NA	NA	NA	NA	NA	NA	NA	<1
TGSC-X8	chloroform	NA	NA	NA	NA	NA	NA	NA	NA	NA	NA	NA	NA	NA	<1

Notes: NA = Not analyzed; ND = Not detected; ERT = SRTC Environmental Restoration Technology Section; EBS = SRTC Environmental Bib Technology Section; ADS = SRTC Analytical Development Section
All concentrations in ug/L (ppb)

Appendix B-2

1 gpm Steady State CVOC Data Summary - ADS Laboratory
(9/30/97 at 0.97 gpm)

Sample location	Distance into Cell (ft)	PCE	TCE	cDCE	VC	CT	TCM	DCM	CM	111-TCA
TCM-2	0	NA	NA	NA	NA	NA	NA	NA	NA	NA
TGSC-1A	0	1.6	156.0	22.0	<1	20.0	2.2	<1	<1	<1
TGSC-1B	0.14	<1	27.0	3.5	<1	<1	<1	<1	<1	<1
TGSC-1B	0.14	<5	29.0	<5	<5	<5	<5	<5	<5	<5
TGSC-1B	0.14	<5	27.0	<5	<5	<5	<5	<5	<5	<5
TGSC-1C	0.32	<1	5.4	3.3	<1	<1	<1	<1	<1	<1
TGSC-1D	0.64	<1	<1	2.6	<1	<1	<1	<1	<1	<1
TGSC-1E	1.07	<1	<1	1.1	<1	<1	<1	<1	<1	<1
TGSC-1F	1.5	<1	<1	<1	<1	<1	<1	<1	<1	<1
TGSC-1G	2.04	<1	<1	<1	<1	<1	<1	<1	<1	<1
TGSC-1H	2.86	<1	<1	<1	<1	<1	<1	<1	<1	<1
TGSC-1I	3.47	<1	<1	<1	<1	<1	<1	<1	<1	<1
TGSC-1S	-	<1	<1	<1	<1	<1	<1	<1	<1	<1
TGSC-X8	-	<1	<1	<1	<1	<1	<1	<1	<1	<1

Notes:

- PCE = tetrachloroethylene; TCE = trichloroethylene; cDCE = cis-1,2-dichloroethylene; VC = vinyl chloride
- CT = carbon tetrachloride; TCM = chloroform; DCM = methylene chloride; CM = methyl chloride
- 111-TCA = 1,1,1-trichloroethane
- All concentrations in ug/L (ppb)
- ADS = SRTC Analytical Development Section

Appendix B-3

1 gpm Steady State Inorganic Data Summary - ADS Laboratory
(9/30/97 at 0.97 gpm)

Sample location	Distance into Cell (ft)	Al	B	Ba	Ca	Cd	Cr	Cu	Fe	Mg	Mn	Na	Ni
TCM-2	0	NA	NA	NA	NA	NA	NA	NA	NA	NA	NA	NA	NA
TGSC-1A	0	0.219	0.850	<0.013	2.798	<0.004	<0.015	<0.024	0.969	0.881	0.027	13.858	<0.027
TGSC-1B	0.14	<0.216	0.762	<0.013	2.947	<0.004	0.101	<0.024	15.087	0.613	0.157	6.651	0.057
TGSC-1C	0.32	<0.216	0.696	<0.013	3.358	<0.004	0.017	<0.024	8.396	0.668	0.214	4.721	<0.027
TGSC-1D	0.64	<0.216	0.659	<0.013	3.344	<0.004	<0.015	<0.024	3.333	0.673	0.234	4.765	<0.027
TGSC-1E	1.07	<0.216	0.753	<0.013	3.522	<0.004	<0.015	<0.024	3.972	0.701	0.461	4.843	<0.027
TGSC-1F	1.5	<0.216	0.743	<0.013	4.100	<0.004	<0.015	<0.024	4.605	0.758	0.371	4.722	<0.027
TGSC-1G	2.04	<0.216	0.594	<0.013	3.613	<0.004	<0.015	<0.024	1.704	0.713	0.377	3.871	<0.027
TGSC-1H	2.86	<0.216	0.618	<0.013	4.089	<0.004	<0.015	<0.024	2.036	0.801	0.833	3.885	<0.027
TGSC-1I	3.47	<0.216	0.619	<0.013	5.165	<0.004	<0.015	<0.024	0.170	1.100	0.151	8.304	<0.027
TGSC-1S	-	<0.216	0.654	<0.013	5.749	<0.004	<0.015	<0.024	0.269	1.048	0.146	7.870	<0.027
TGSC-X8	-	<0.216	0.664	<0.013	4.579	<0.004	<0.015	<0.024	0.119	0.973	0.007	7.488	<0.027

Sample location	Distance into Cell (ft)	P	Si	Sr	Zn	Chloride	Fluoride	Formate	Nitrate	Nitrite	Sulfate	Alkalinity
TCM-2	0	NA	NA	NA	NA	NA	NA	NA	NA	NA	NA	NA
TGSC-1A	0	0.073	8.632	<0.006	0.013	4	<0.2	<1	28	<1	8	<25
TGSC-1B	0.14	<0.025	6.817	<0.006	0.007	3	0.5	<1	<1	<1	7	<25
TGSC-1C	0.32	<0.025	4.895	<0.006	0.121	3	0.6	<1	<1	<1	6	<25
TGSC-1D	0.64	<0.025	4.467	<0.006	0.013	<1	<0.2	<1	<1	<1	4	<25
TGSC-1E	1.07	<0.025	5.650	<0.006	0.058	4	<0.2	<1	<1	<1	3	<25
TGSC-1F	1.5	<0.025	6.967	0.007	0.159	4	<0.2	<1	<1	<1	4	<25
TGSC-1G	2.04	<0.025	5.753	<0.006	0.023	4	<0.2	<1	<1	<1	1	<25
TGSC-1H	2.86	<0.025	5.777	<0.006	0.013	2	<0.2	<1	<1	<1	4	<25
TGSC-1I	3.47	<0.025	6.626	0.015	<0.004	2	<0.2	<1	<1	<1	13	<25
TGSC-1S	-	<0.025	6.430	0.014	0.292	2	<0.2	<1	<1	<1	12	<25
TGSC-X8	-	<0.025	6.932	0.012	0.017	2	<0.2	<1	<1	<1	12	<25

Notes:

- 1) All units in mg/L
 - 2) Only parameters which had at least one analysis above detection at any of the steady state flow rates are shown in the table.
 - 3) The following parameters were all below their respective detection limits:
Ag (<0.036); Co (<0.021); La (<0.040); Li (<0.018); Mo (<0.017); Pb (<0.076); Sn (<0.027); Ti (<0.017); V (<0.020); Zr (<0.048); Oxalate (<1); Phosphate (<1)
- ADS = SRTC Analytical Development Section

1 gpm Testing - Field Data Summary

Sample Location	Distance into Cell (ft)	Organization	ERT	ERT	ERT	ERT
		Date	8/26/97	9/2/97	9/23/97	9/30/97
		Time	8:50 - 10:38	9:17 - 10:36	8:49 - 9:50	8:35 - 10:50
		Flow (gpm)	1.02	1.07	0.96	0.97
		Parameter				

TCM-2	0	pH	NA	NA	NA	NA
TGSC-1A	0	pH	NA	NA	NA	5.3
TGSC-1B	0.14	pH	6.67	6.96	6.66	7.01
TGSC-1C	0.32	pH	6.51	6.78	6.58	6.85
TGSC-1D	0.64	pH	6.48	6.67	6.7	6.92
TGSC-1E	1.07	pH	7.27	7.15	7.25	8.08
TGSC-1F	1.5	pH	7.98	7.8	8.14	8.97
TGSC-1G	2.04	pH	8.11	8.35	8.48	8.98
TGSC-1H	2.86	pH	8.32	8.59	8.43	8.64
TGSC-1I	3.47	pH	8.97	9.13	8.97	9.42
TGSC-1S	-	pH	8.92	9.19	9.23	9.52
TGSC-X8	-	pH	8.89	8.96	9.14	9.59

TCM-2	0	DO, mg/l	NA	NA	NA	NA
TGSC-1A	0	DO, mg/l	NA	NA	NA	4.1
TGSC-1B	0.14	DO, mg/l	NA	NA	NA	1.9
TGSC-1C	0.32	DO, mg/l	NA	NA	NA	2
TGSC-1D	0.64	DO, mg/l	NA	NA	NA	2
TGSC-1E	1.07	DO, mg/l	NA	NA	NA	1.7
TGSC-1F	1.5	DO, mg/l	NA	NA	NA	1.9
TGSC-1G	2.04	DO, mg/l	NA	NA	NA	1.9
TGSC-1H	2.86	DO, mg/l	NA	NA	NA	1.9
TGSC-1I	3.47	DO, mg/l	NA	NA	NA	1.9
TGSC-1S	-	DO, mg/l	NA	NA	NA	1.2
TGSC-X8	-	DO, mg/l	NA	NA	NA	1.4

TCM-2	0	Eh, mV	NA	NA	NA	NA
TGSC-1A	0	Eh, mV	NA	NA	NA	NA
TGSC-1B	0.14	Eh, mV	NA	NA	NA	NA
TGSC-1C	0.32	Eh, mV	NA	NA	NA	NA
TGSC-1D	0.64	Eh, mV	NA	NA	NA	NA
TGSC-1E	1.07	Eh, mV	NA	NA	NA	NA
TGSC-1F	1.5	Eh, mV	NA	NA	NA	NA
TGSC-1G	2.04	Eh, mV	NA	NA	NA	NA
TGSC-1H	2.86	Eh, mV	NA	NA	NA	NA
TGSC-1I	3.47	Eh, mV	NA	NA	NA	NA
TGSC-1S	-	Eh, mV	NA	NA	NA	NA
TGSC-X8	-	Eh, mV	NA	NA	NA	NA

TCM-2	0	Temp. °C	NA	NA	NA	NA
TGSC-1A	0	Temp. °C	NA	NA	NA	16.8
TGSC-1B	0.14	Temp. °C	20.6	23.6	26.1	17.6
TGSC-1C	0.32	Temp. °C	20.5	24	27.2	17.8
TGSC-1D	0.64	Temp. °C	20.5	23.9	27.7	17.6
TGSC-1E	1.07	Temp. °C	20.3	24	29.7	18
TGSC-1F	1.5	Temp. °C	21.2	23.9	34.8	18.5
TGSC-1G	2.04	Temp. °C	20.9	24.4	29.7	19
TGSC-1H	2.86	Temp. °C	21.4	24.8	27.7	19.3
TGSC-1I	3.47	Temp. °C	21.1	25.3	28.5	19.5
TGSC-1S	-	Temp. °C	21.5	23.8	25.6	20.6
TGSC-X8	-	Temp. °C	21.9	24.9	20.5	19.8

Notes: NA = Not analyzed; ERT = SRTC Environmental Restoration Technology Section

4 gpm Testing - CVOC Data Summary

Sample Location	Distance into Cell (ft)	Laboratory	ERT	ERT	ERT	ERT	ERT	ERT	ERT	ERT	ADS
		Date	10/7/97	10/15/97	10/23/97	10/28/97	11/4/97	11/11/97	11/11/97	11/11/97	11/11/97
Time		7:57 - 8:55	7:55 - 9:00	8:12 - 10:25	8:15 - 9:40	8:14 - 10:45	8:35 - 10:32	8:35 - 10:32	8:35 - 10:32	8:35 - 10:32	8:35 - 10:32
Flow (gpm)		3.94	?	3.64	3.94	4.08	4.00	4.00	4.00	4.00	
Compound											

TCM-2	0	trichloroethylene	NA	NA	NA	NA	NA	245.7	240.7	143.7
TGSC-1A	0	trichloroethylene	258.6	262.2	243.0	198.1	209.9	168.1	225.9	156.1
TGSC-1B	0.14	trichloroethylene	188.4	207.2	147.6	130.6	185.6	157.8	187.6	158.8
TGSC-1C	0.32	trichloroethylene	47.3	126.4	109.5	92.6	79.9	102.3	85.9	66.9
TGSC-1D	0.64	trichloroethylene	19.5	69.6	74.0	60.9	37.6	44.0	36.7	27.8
TGSC-1E	1.07	trichloroethylene	ND	1.2	3.9	4.1	2.7	3.9	3.9	2.4
TGSC-1F	1.5	trichloroethylene	ND	ND	ND	ND	ND	ND	ND	<1
TGSC-1G	2.04	trichloroethylene	ND	ND	ND	ND	ND	ND	ND	<1
TGSC-1H	2.86	trichloroethylene	ND	ND	ND	ND	ND	ND	ND	<1
TGSC-1I	3.47	trichloroethylene	1.0	2.3	1.9	0.7	0.7	1.3	1.1	<1
TGSC-1S	-	trichloroethylene	0.6	1.3	1.4	1.0	0.9	1.1	1.0	<1
TGSC-X8	-	trichloroethylene	0.6	1.3	1.3	0.9	0.8	1.0	1.0	<1

TCM-2	0	cis-1,2-dichloroethylene	NA	NA	NA	NA	NA	38.0	23.2	24.1
TGSC-1A	0	cis-1,2-dichloroethylene	36.2	37.6	29.0	30.6	29.9	32.5	24.8	25.2
TGSC-1B	0.14	cis-1,2-dichloroethylene	37.0	31.0	21.0	22.3	28.2	28.9	20.2	22.7
TGSC-1C	0.32	cis-1,2-dichloroethylene	18.5	23.4	22.4	20.2	25.3	27.7	17.7	17.8
TGSC-1D	0.64	cis-1,2-dichloroethylene	8.0	20.7	18.9	17.7	15.4	17.7	12.4	11.5
TGSC-1E	1.07	cis-1,2-dichloroethylene	ND	ND	ND	ND	ND	ND	ND	2.3
TGSC-1F	1.5	cis-1,2-dichloroethylene	ND	ND	ND	ND	ND	ND	ND	0.8
TGSC-1G	2.04	cis-1,2-dichloroethylene	ND	ND	ND	ND	ND	ND	ND	0.4
TGSC-1H	2.86	cis-1,2-dichloroethylene	ND	ND	ND	ND	ND	ND	ND	0.2
TGSC-1I	3.47	cis-1,2-dichloroethylene	ND	ND	ND	ND	ND	ND	ND	3.6
TGSC-1S	-	cis-1,2-dichloroethylene	ND	ND	ND	ND	ND	ND	ND	2.7
TGSC-X8	-	cis-1,2-dichloroethylene	ND	ND	ND	ND	ND	ND	ND	2.9

TCM-2	0	Carbon Tetrachloride	NA	NA	NA	NA	NA	45.4	24.8	16.5
TGSC-1A	0	Carbon Tetrachloride	14.2	15.5	8.7	11.1	12.8	13.4	12.9	7
TGSC-1B	0.14	Carbon Tetrachloride	ND	ND	ND	ND	ND	0.1	0.1	<1
TGSC-1C	0.32	Carbon Tetrachloride	ND	ND	ND	ND	ND	ND	ND	<1
TGSC-1D	0.64	Carbon Tetrachloride	ND	ND	ND	ND	ND	ND	ND	<1
TGSC-1E	1.07	Carbon Tetrachloride	ND	ND	ND	ND	ND	ND	ND	<1
TGSC-1F	1.5	Carbon Tetrachloride	ND	ND	ND	ND	ND	ND	ND	<1
TGSC-1G	2.04	Carbon Tetrachloride	ND	ND	ND	ND	ND	ND	ND	<1
TGSC-1H	2.86	Carbon Tetrachloride	ND	ND	ND	ND	ND	ND	ND	<1
TGSC-1I	3.47	Carbon Tetrachloride	ND	ND	ND	ND	ND	ND	ND	<1
TGSC-1S	-	Carbon Tetrachloride	ND	ND	ND	ND	ND	ND	ND	<1
TGSC-X8	-	Carbon Tetrachloride	ND	ND	ND	ND	ND	ND	ND	<1

TCM-2	0	chloroform	NA	NA	NA	NA	NA	3.5	3.3	2.7
TGSC-1A	0	chloroform	6.5	7.9	6.7	7.3	7.3	6.9	8.1	6.7
TGSC-1B	0.14	chloroform	6.2	6.3	3.5	3.9	6.4	6.5	6.9	6.3
TGSC-1C	0.32	chloroform	2.5	4.3	2.4	2.2	1.9	1.7	2.0	1.8
TGSC-1D	0.64	chloroform	1.7	2.8	1.3	1.1	0.8	0.8	0.9	0.8
TGSC-1E	1.07	chloroform	ND	ND	ND	ND	ND	ND	ND	<1
TGSC-1F	1.5	chloroform	ND	ND	ND	ND	ND	ND	ND	<1
TGSC-1G	2.04	chloroform	ND	ND	ND	ND	ND	ND	ND	<1
TGSC-1H	2.86	chloroform	ND	ND	ND	ND	ND	ND	ND	<1
TGSC-1I	3.47	chloroform	ND	ND	ND	ND	ND	ND	ND	<1
TGSC-1S	-	chloroform	ND	ND	ND	ND	ND	ND	ND	<1
TGSC-X8	-	chloroform	ND	ND	ND	ND	ND	ND	ND	<1

Notes: NA = Not analyzed; ND = Not detected;
ERT = SRTC Environmental Restoration Technology Section;
EBS = SRTC Environmental BioTechnology Section;
ADS = SRTC Analytical Development Section
All concentrations in ug/L (ppb)

Appendix B-6

4 gpm Steady State CVOC Data Summary - ADS Laboratory
(11/11/97 at 4.00 gpm)

Sample location	Distance into Cell (ft)	PCE	TCE	cDCE	VC	CT	TCM	DCM	CM	111-TCA
TCM-2	0	2.2	143.6	24.0	<1	16.4	2.8	<1	<1	<1
TCM-2	0	2.1	143.7	24.1	<1	16.5	2.7	<1	<1	<1
TGSC-1A	0	1.9	156.1	25.2	<1	7.0	6.7	<1	<1	<1
TGSC-1A	0	2.1	151.9	25.8	<1	7.0	6.7	<1	<1	<1
TGSC-1B	0.14	2.1	158.8	22.7	<1	<1	6.3	<1	<1	<1
TGSC-1C	0.32	1.1	66.4	17.4	<1	<1	1.7	<1	<1	<1
TGSC-1C	0.32	1.2	66.9	17.8	<1	<1	1.8	<1	<1	<1
TGSC-1D	0.64	<1	27.8	11.5	<1	<1	0.8	<1	<1	<1
TGSC-1E	1.07	<1	2.4	2.3	<1	<1	<1	<1	<1	<1
TGSC-1F	1.5	<1	<1	0.8	<1	<1	<1	<1	<1	<1
TGSC-1G	2.04	<1	<1	0.4	<1	<1	<1	<1	<1	<1
TGSC-1H	2.86	<1	<1	0.2	<1	<1	<1	<1	<1	<1
TGSC-1I	3.47	<1	<1	3.6	<1	<1	<1	<1	<1	<1
TGSC-1S	-	<1	<1	2.7	<1	<1	<1	<1	<1	<1
TGSC-X8	-	<1	<1	2.9	<1	<1	<1	<1	<1	<1

Notes:

- PCE = tetrachloroethylene; TCE = trichloroethylene; cDCE = cis-1,2-dichloroethylene; VC = vinyl chloride
- CT = carbon tetrachloride; TCM = chloroform; DCM = methylene chloride; CM = methyl chloride
- 111-TCA = 1,1,1-trichloroethane
- All concentrations in ug/L (ppb)
- ADS = SRTC Analytical Development Section

Appendix B-7

4 gpm Steady State Inorganic Data Summary - ADS Laboratory
(11/11/97 at 4.00 gpm)

Sample location	Distance into Cell (ft)	Al	B	Ba	Ca	Cd	Cr	Cu	Fe	Mg	Mn	Na	Ni
TGM-2	0	1.263	0.100	<0.013	5.207	<0.004	<0.015	<0.024	0.115	1.810	0.091	15.988	<0.027
TGSC-1A	0	17.097	0.191	<0.013	12.133	<0.004	<0.015	<0.024	0.308	1.541	0.152	53.049	<0.027
TGSC-1B	0.14	6.980	0.196	<0.013	7.372	<0.004	<0.015	<0.024	48.261	1.075	0.378	49.999	<0.027
TGSC-1C	0.32	1.611	0.157	<0.013	4.333	<0.004	<0.015	<0.024	16.506	0.820	0.317	43.345	<0.027
TGSC-1D	0.64	15.084	0.108	<0.013	9.757	<0.004	<0.015	<0.024	6.010	1.099	0.231	28.260	0.144
TGSC-1E	1.07	4.135	<0.048	<0.013	6.961	<0.004	<0.015	<0.024	4.898	0.875	0.171	5.385	0.049
TGSC-1F	1.5	4.217	<0.048	<0.013	7.366	<0.004	<0.015	<0.024	2.052	0.906	0.186	5.271	<0.027
TGSC-1G	2.04	2.963	<0.048	<0.013	9.371	<0.004	<0.015	<0.024	1.960	1.054	0.184	5.375	<0.027
TGSC-1H	2.86	2.017	<0.048	<0.013	7.583	<0.004	0.057	<0.024	3.004	0.913	0.158	4.552	0.042
TGSC-1I	3.47	3.339	0.065	0.017	8.549	<0.004	<0.015	<0.024	0.407	1.186	0.190	13.771	<0.027
TGSC-1S	-	7.775	0.063	0.022	8.342	<0.004	<0.015	<0.024	1.153	1.175	0.226	11.923	<0.027
TGSC-X8	-	8.125	0.059	0.020	6.480	<0.004	<0.015	<0.024	0.300	1.055	0.176	10.800	<0.027

Sample location	Distance into Cell (ft)	P	Si	Sr	Zn	Chloride	Fluoride	Formate	Nitrate	Nitrite	Sulfate	Alkalinity
TGM-2	0	<0.025	4.760	0.018	0.030	8	<0.2	<1	49	<1	5	>25
TGSC-1A	0	0.133	7.135	0.014	0.029	9	<0.2	<1	69	<1	21	<25
TGSC-1B	0.14	0.038	6.548	<0.006	0.026	9	<0.2	<1	24	<1	20	<25
TGSC-1C	0.32	<0.025	4.355	<0.006	0.024	8	<0.2	<1	<1	<1	17	<25
TGSC-1D	0.64	0.052	3.070	0.012	0.039	6	<0.2	<1	<1	<1	5	<25
TGSC-1E	1.07	<0.025	0.767	0.009	0.109	3	0.5	<1	<1	<1	<0.5	<25
TGSC-1F	1.5	0.039	0.190	0.014	0.030	3	<0.2	0.6	<1	<1	<0.5	<25
TGSC-1G	2.04	0.050	0.244	0.019	0.024	3	<0.2	2	<1	<1	<0.5	<25
TGSC-1H	2.86	0.040	0.325	0.017	0.033	3	<0.2	1.3	<1	<1	<0.5	<25
TGSC-1I	3.47	0.054	0.183	0.022	0.048	5	0.2	0.8	<1	<1	2	<25
TGSC-1S	-	0.040	0.259	0.021	0.045	9	0.3	1	<1	<1	3	<25
TGSC-X8	-	0.027	0.259	0.018	0.031	4	0.2	0.9	<1	<1	2	<25

Notes:

- 1) All units in mg/L
 - 2) Only parameters which had at least one analysis above detection at any of the steady state flow rates are shown in the table.
 - 3) The following parameters were all below their respective detection limits:
Ag (<0.036); Co (<0.021); La (<0.040); Li (<0.018); Mo (<0.017); Pb (<0.076); Sn (<0.027); Ti (<0.017); V (<0.020); Zr (<0.048); Oxalate (<1); Phosphate (<1)
- ADS = SRTC Analytical Development Section

4 gpm Testing - Field Data Summary

Sample Location	Distance into Cell (ft)	Organization	ERT	ERT	ERT	ERT	ERT	ERT
		Date	10/7/97	10/15/97	10/23/97	10/28/97	11/4/97	11/11/97
		Time	7:57 - 8:55	7:55 - 9:00	8:12 - 10:25	8:15 - 9:40	8:14 - 10:45	8:35 - 10:32
		Flow (gpm)	3.94	?	3.64	3.94	4.08	4.00
		Parameter						

TCM-2	0	pH	NA	NA	NA	NA	NA	4.46
TGSC-1A	0	pH	5.41	5.64	5.66	5.54	5.04	5.15
TGSC-1B	0.14	pH	7.15	7.18	7.08	6.91	6.32	6.52
TGSC-1C	0.32	pH	6.93	7.33	7.17	7.07	6.72	6.83
TGSC-1D	0.64	pH	7.07	7.36	7.24	7.23	6.72	6.93
TGSC-1E	1.07	pH	6.85	7.13	6.72	6.55	6.45	6.37
TGSC-1F	1.5	pH	6.86	7.26	6.77	7.44	6.78	6.83
TGSC-1G	2.04	pH	6.8	7.35	8.18	8.02	7.41	7.29
TGSC-1H	2.86	pH	6.83	7.22	7.75	6.91	7.71	6.8
TGSC-1I	3.47	pH	8.54	8.81	8.82	9.05	7.79	9
TGSC-1S	-	pH	7.91	7.95	8.52	8.75	8.53	8.81
TGSC-X8	-	pH	8.11	8.08	8.52	9.05	8.81	8.48

TCM-2	0	DO, mg/l	NA	NA	NA	NA	NA	3.1
TGSC-1A	0	DO, mg/l	NA	NA	NA	NA	NA	4.2
TGSC-1B	0.14	DO, mg/l	NA	NA	NA	NA	NA	2.4
TGSC-1C	0.32	DO, mg/l	NA	NA	NA	NA	NA	1.9
TGSC-1D	0.64	DO, mg/l	NA	NA	NA	NA	NA	1.9
TGSC-1E	1.07	DO, mg/l	NA	NA	NA	NA	NA	2.6
TGSC-1F	1.5	DO, mg/l	NA	NA	NA	NA	NA	2.7
TGSC-1G	2.04	DO, mg/l	NA	NA	NA	NA	NA	2.3
TGSC-1H	2.86	DO, mg/l	NA	NA	NA	NA	NA	2.1
TGSC-1I	3.47	DO, mg/l	NA	NA	NA	NA	NA	2.2
TGSC-1S	-	DO, mg/l	NA	NA	NA	NA	NA	1.7
TGSC-X8	-	DO, mg/l	NA	NA	NA	NA	NA	1.6

TCM-2	0	Eh, mV	NA	NA	NA	NA	NA	453.1
TGSC-1A	0	Eh, mV	NA	NA	NA	420.7	438.4	316.3
TGSC-1B	0.14	Eh, mV	NA	NA	NA	101.3	64	71.4
TGSC-1C	0.32	Eh, mV	NA	NA	NA	-303	-47.6	-1.1
TGSC-1D	0.64	Eh, mV	NA	NA	NA	-319	-42.8	7.1
TGSC-1E	1.07	Eh, mV	NA	NA	NA	-368	-189.7	-12.1
TGSC-1F	1.5	Eh, mV	NA	NA	NA	-404	-231	-85.2
TGSC-1G	2.04	Eh, mV	NA	NA	NA	-445	-252	-121.3
TGSC-1H	2.86	Eh, mV	NA	NA	NA	-444	-261	-166.7
TGSC-1I	3.47	Eh, mV	NA	NA	NA	-492	-214	-129.3
TGSC-1S	-	Eh, mV	NA	NA	NA	-489	-441	-140.2
TGSC-X8	-	Eh, mV	NA	NA	NA	-296	-224	-74.3

TCM-2	0	Temp. °C	NA	NA	NA	NA	NA	16.8
TGSC-1A	0	Temp. °C	19.1	21.3	14	13.7	13.7	12.2
TGSC-1B	0.14	Temp. °C	19.3	21.1	13.5	12.7	13.9	13.4
TGSC-1C	0.32	Temp. °C	18.5	21	13.3	13.8	14.9	14.4
TGSC-1D	0.64	Temp. °C	18.9	20.9	13.8	14.3	14.5	14.4
TGSC-1E	1.07	Temp. °C	18.7	21.1	13.8	12.1	15.6	14.3
TGSC-1F	1.5	Temp. °C	18.6	21.1	13.7	13.4	14.8	14.3
TGSC-1G	2.04	Temp. °C	18.7	21	14.1	14.7	15.3	15.6
TGSC-1H	2.86	Temp. °C	19.1	21	14.6	13.3	15.4	14.8
TGSC-1I	3.47	Temp. °C	19.1	21.2	13.9	14.6	15.9	14.5
TGSC-1S	-	Temp. °C	18.7	20.1	14.7	15.4	15.8	16
TGSC-X8	-	Temp. °C	18.9	20	14.6	15	14.1	15.2

Notes: NA = Not analyzed; ERT = SRTC Environmental Restoration Technology Section
The flow meter was inoperative on 10/15/97; therefore a flow rate was not recorded.

8 gpm Testing - CVOC Data Summary

Sample Location	Distance into Cell (ft)	Laboratory	ERT	ERT	ERT	ERT	ERT	ERT	ERT	ERT	ERT	ADS	GEL	GEL
		Date	11/18/97	11/25/97	12/2/97	12/2/97	12/9/97	12/9/97	12/9/97	12/16/97	12/16/97	12/16/97	12/16/97	12/16/97
		Time	8:25 - 10:55	8:25 - 9:45	8:10 - 9:40	8:10 - 9:40	13:23 - 14:55	13:23 - 14:55	8:52 - 9:49	8:52 - 9:49	8:52 - 9:49	8:52 - 9:49	8:52 - 9:49	8:52 - 9:49
		Flow (gpm)	8.05	7.8	7.68	7.68	7.89	7.89	7.98	7.98	7.98	7.98	7.98	
		Compound												

TCM-2	0	Trichloroethylene	NA	NA	199.7	234.1	NA	NA	215.5	222.0	135.85	206	234
TGSC-1A	0	Trichloroethylene	227.9	177.2	181.9	205.6	211.9	213.8	183.8	190.0	133.65	158	163
TGSC-1B	0.14	Trichloroethylene	196.5	138.8	101.0	109.2	57.1	56.5	42.3	44.0	9.45	52.3	56.1
TGSC-1C	0.32	Trichloroethylene	105.0	91.4	86.9	80.7	73.4	73.4	51.8	55.4	44.6	45.0	49.1
TGSC-1D	0.64	Trichloroethylene	82.6	83.1	85.2	84.5	76.8	74.0	54.8	57.9	40.3	44.6	46.8
TGSC-1E	1.07	Trichloroethylene	21.3	25.1	60.6	33.7	31.4	29.6	28.9	30.8	20.3	26.0	24.5
TGSC-1F	1.5	Trichloroethylene	ND	0.5	1.2	1.3	1.8	1.5	1.0	1.3	< 1	0.950	1.16
TGSC-1G	2.04	Trichloroethylene	ND	ND	ND	ND	ND	ND	0.3	0.3	< 1	<1.00	0.275
TGSC-1H	2.86	Trichloroethylene	ND	ND	ND	ND	0.2	ND	0.2	0.2	< 1	<1.00	<1.00
TGSC-1I	3.47	Trichloroethylene	2.8	4.6	5.2	6.9	5.3	4.6	5.4	5.0	3.4	4.55	4.01
TGSC-1S	-	Trichloroethylene	3.7	5.2	4.8	6.0	5.3	4.9	5.6	5.0	3.55	4.28	4.48
TGSC-X8	-	Trichloroethylene	3.9	4.7	5.1	6.2	5.3	5.0	5.2	4.5	3.5	3.94	5.63

TCM-2	0	cis-1,2-dichloroethylene	NA	NA	48.8	28.6	NA	NA	26.0	26.4	21.35	36.6	37.5
TGSC-1A	0	cis-1,2-dichloroethylene	32.2	21.8	50.9	25.3	25.9	25.8	26.0	38.2	19.55	27.6	27.4
TGSC-1B	0.14	cis-1,2-dichloroethylene	31.4	17.0	31.4	16.9	10.4	11.0	15.3	19.9	2.15	16.3	17.0
TGSC-1C	0.32	cis-1,2-dichloroethylene	20.5	14.5	27.1	13.4	12.6	13.8	12.0	12.6	11.2	15.8	16.6
TGSC-1D	0.64	cis-1,2-dichloroethylene	20.1	15.1	29.6	15.9	36.4	15.1	22.3	32.0	11.2	17.1	17.5
TGSC-1E	1.07	cis-1,2-dichloroethylene	ND	ND	ND	ND	ND	ND	11.9	ND	4.1	6.33	6.38
TGSC-1F	1.5	cis-1,2-dichloroethylene	ND	ND	ND	ND	ND	ND	ND	ND	1.3	1.45	1.72
TGSC-1G	2.04	cis-1,2-dichloroethylene	ND	ND	ND	ND	ND	ND	ND	ND	< 1	0.700	0.965
TGSC-1H	2.86	cis-1,2-dichloroethylene	ND	ND	ND	ND	ND	ND	ND	ND	< 1	<1.00	<1.00
TGSC-1I	3.47	cis-1,2-dichloroethylene	ND	ND	20.6	10.2	10.0	ND	9.6	14.0	5.1	7.84	7.35
TGSC-1S	-	cis-1,2-dichloroethylene	ND	ND	ND	ND	ND	ND	ND	7.7	4.85	7.02	5.92
TGSC-X8	-	cis-1,2-dichloroethylene	ND	ND	ND	ND	ND	ND	ND	7.1	4.55	5.99	7.23

TCM-2	0	Carbon Tetrachloride	NA	NA	24.8	27.3	NA	NA	23.9	25.5	18.15	22.5	23.4
TGSC-1A	0	Carbon Tetrachloride	17.2	8.5	44.8	9.7	9.6	9.2	9.2	9.7	7.75	8.77	8.92
TGSC-1B	0.14	Carbon Tetrachloride	0.2	0.1	0.1	0.1	ND	ND	ND	ND	< 1	<1.00	<1.00
TGSC-1C	0.32	Carbon Tetrachloride	ND	ND	ND	ND	ND	ND	ND	ND	< 1	<1.00	<1.00
TGSC-1D	0.64	Carbon Tetrachloride	ND	ND	ND	ND	ND	ND	ND	ND	< 1	<1.00	<1.00
TGSC-1E	1.07	Carbon Tetrachloride	ND	ND	ND	ND	ND	ND	ND	ND	< 1	<1.00	<1.00
TGSC-1F	1.5	Carbon Tetrachloride	ND	ND	ND	ND	ND	ND	ND	ND	< 1	<1.00	<1.00
TGSC-1G	2.04	Carbon Tetrachloride	ND	ND	ND	ND	ND	ND	ND	ND	< 1	<1.00	<1.00
TGSC-1H	2.86	Carbon Tetrachloride	ND	ND	ND	ND	ND	ND	ND	ND	< 1	<1.00	<1.00
TGSC-1I	3.47	Carbon Tetrachloride	ND	ND	ND	ND	ND	ND	ND	ND	< 1	<1.00	<1.00
TGSC-1S	-	Carbon Tetrachloride	ND	ND	ND	ND	ND	ND	ND	ND	< 1	<1.00	<1.00
TGSC-X8	-	Carbon Tetrachloride	ND	ND	ND	ND	ND	ND	ND	ND	< 1	<1.00	<1.00

TCM-2	0	chloroform	NA	NA	2.8	5.2	NA	NA	3.2	3.7	3.35	3.65	3.78
TGSC-1A	0	chloroform	9.4	6.2	6.1	7.9	7.1	6.7	6.2	6.2	5.95	6.13	6.12
TGSC-1B	0.14	chloroform	8.8	4.8	2.8	4.7	1.9	1.8	1.4	1.6	< 1	2.22	2.41
TGSC-1C	0.32	chloroform	4.0	2.3	1.8	2.0	2.2	1.9	1.5	1.9	1.5	1.76	2.06
TGSC-1D	0.64	chloroform	2.6	2.3	1.8	2.2	2.9	2.5	2.4	2.9	1.9	2.36	2.27
TGSC-1E	1.07	chloroform	0.5	0.4	0.8	1.0	0.9	0.8	0.8	1.0	< 1	0.779	0.738
TGSC-1F	1.5	chloroform	ND	ND	ND	ND	ND	ND	ND	ND	< 1	<1.00	<1.00
TGSC-1G	2.04	chloroform	ND	ND	ND	ND	ND	ND	ND	ND	< 1	<1.00	<1.00
TGSC-1H	2.86	chloroform	ND	ND	ND	ND	ND	ND	ND	ND	< 1	<1.00	<1.00
TGSC-1I	3.47	chloroform	0.3	0.3	0.3	0.3	ND	ND	ND	ND	< 1	0.317	<1.00
TGSC-1S	-	chloroform	0.3	0.2	ND	ND	ND	0.3	ND	0.4	< 1	0.269	0.311
TGSC-X8	-	chloroform	0.3	ND	ND	ND	ND	0.3	ND	ND	< 1	0.310	0.368

Notes: NA = Not analyzed; ND = Not detected;
 ERT = SRTC Environmental Restoration Technology Section;
 EBS = SRTC Environmental BioTechnology Section;
 ADS = SRTC Analytical Development Section
 GEL = General Engineering Laboratories, Inc.
 All concentrations in ug/L (ppb)

Appendix B-10

8 gpm Steady State CVOC Data Summary - ADS Laboratory
(12/16/97 at 7.98 gpm)

Sample location	Distance into Cell (ft)	PCE	TCE	cDCE	VC	CT	TCM	DCM	CM	111-TCA	CACT	ACT
TGM-2	0	1.9	131.8	20.8		1	16.9	2.4	<1	<1	<30	<13
TGM-2	0	<5	139.9	21.9		<5	19.4	4.3	<5	<5	-	-
TGSC-1A	0	1.6	118.2	17.2		<1	6.8	4.7	<1	<1	<30	<13
TGSC-1A	0	<5	149.1	21.9		<5	8.7	7.2	<5	<5	-	-
TGSC-1B	0.14	<1	8.8	2		<1	<1	<1	<1	<1	<30	<13
TGSC-1B	0.14	<1	10.1	2.3		<1	<1	<1	<1	<1	-	-
TGSC-1C	0.32	1.2	44.6	11.2		<1	<1	1.5	<1	<1	<30	<13
TGSC-1D	0.64	1.1	40.3	11.2		<1	<1	1.9	<1	<1	<30	<13
TGSC-1E	1.07	<1	20.3	4.1		<1	<1	<1	<1	<1	<30	<13
TGSC-1F	1.5	<1	<1	1.3		<1	<1	<1	<1	<1	<30	<13
TGSC-1G	2.04	<1	<1	<1		<1	<1	<1	<1	<1	<30	<13
TGSC-1H	2.86	<1	<1	<1		<1	<1	<1	<1	<1	<30	<13
TGSC-1I	3.47	<1	3.4	5.1		<1	<1	<1	<1	<1	<30	<13
TGSC-1S	-	<1	3.4	4.8		<1	<1	<1	<1	<1	<30	<13
TGSC-1S	-	<1	3.7	4.9		<1	<1	1.1	<1	<1	-	-
TGSC-X8	-	<1	3.4	4.6		<1	<1	<1	<1	<1	<30	<13
TGSC-X8	-	<1	3.6	4.5		1	<1	1.1	<1	<1	-	-

Notes:
 PCE = tetrachloroethylene; TCE = trichloroethylene; cDCE = cis-1,2-dichloroethylene; VC = vinyl chloride
 CT = carbon tetrachloride; TCM = chloroform; DCM = methylene chloride; CM = methyl chloride
 111-TCA = 1,1,1-trichloroethane; CACT = chloroacetylene; ACT = acetylene
 All concentrations in ug/L (ppb)
 ADS = SRTC Analytical Development Section

8 gpm Steady State CVOC Data Summary - GEL Laboratory
(12/16/97 at 7.98 gpm)

Sample Location	Distance into Cell (ft)	Parameter													
		PCE	TCE	cDCE	IDCE	VC	CT	TCM	DCM	CM	111-TCA	Cbenzene	Benzene		
TCM-2	0.00	2.54	206.	36.6	0.288	<1.00	22.5	<1.00	<1.00	<1.00	<1.00	<1.00	<1.00		
TCM-2	0.00	2.60	234.	37.5	0.270	<1.00	23.4	<1.00	<1.00	<1.00	<1.00	<1.00	<1.00		
Average	0.00	2.6	220.0	37.1	0.3	<1.00	23.0	<1.00	<1.00	<1.00	<1.00	<1.00	<1.00		
TGSC-1A	0.00	0.674	158.	27.6	0.287	<1.00	8.77	<1.00	<1.00	<1.00	<1.00	<1.00	<1.00		
TGSC-1A	0.00	0.785	163.	27.4	0.239	<1.00	8.92	<1.00	<1.00	<1.00	<1.00	<1.00	<1.00		
Average	0.00	0.7	160.5	27.5	0.3	<1.00	8.8	<1.00	<1.00	<1.00	<1.00	<1.00	<1.00		
TGSC-1B	0.14	<1.00	52.3	16.3	<1.00	<1.00	<1.00	<1.00	<1.00	<1.00	<1.00	<1.00	<1.00		
TGSC-1B	0.14	<1.00	56.1	17.0	<1.00	<1.00	<1.00	<1.00	<1.00	<1.00	<1.00	<1.00	<1.00		
Average	0.14	<1.00	54.2	16.7	<1.00	<1.00	<1.00	<1.00	<1.00	<1.00	<1.00	<1.00	<1.00		
TGSC-1C	0.32	<1.00	45.0	15.8	<1.00	<1.00	1.76	<1.00	<1.00	<1.00	<1.00	<1.00	<1.00		
TGSC-1C	0.32	<1.00	49.1	16.6	<1.00	<1.00	2.06	<1.00	<1.00	<1.00	<1.00	<1.00	<1.00		
Average	0.32	<1.00	47.1	16.2	<1.00	<1.00	1.9	<1.00	<1.00	<1.00	<1.00	<1.00	<1.00		
TGSC-1D	0.64	<1.00	44.6	17.1	<1.00	<1.00	2.36	<1.00	<1.00	<1.00	<1.00	<1.00	<1.00		
TGSC-1D	0.64	<1.00	46.8	17.5	<1.00	<1.00	2.27	<1.00	<1.00	<1.00	<1.00	<1.00	<1.00		
Average	0.64	<1.00	45.7	17.3	<1.00	<1.00	2.3	<1.00	<1.00	<1.00	<1.00	<1.00	<1.00		
TGSC-1E	1.07	<1.00	26.0	6.33	<1.00	<1.00	0.779	<1.00	<1.00	<1.00	<1.00	<1.00	<1.00		
TGSC-1E	1.07	<1.00	24.5	6.38	<1.00	<1.00	0.738	<1.00	<1.00	<1.00	<1.00	<1.00	<1.00		
Average	1.07	<1.00	25.3	6.4	<1.00	<1.00	0.8	<1.00	<1.00	<1.00	<1.00	<1.00	<1.00		
TGSC-1F	1.50	<1.00	0.950	1.45	<1.00	<1.00	<1.00	<1.00	<1.00	<1.00	<1.00	<1.00	<1.00		
TGSC-1F	1.50	<1.00	1.16	1.72	<1.00	<1.00	<1.00	<1.00	<1.00	<1.00	<1.00	<1.00	<1.00		
Average	1.50	<1.00	1.1	1.6	<1.00	<1.00	<1.00	<1.00	<1.00	<1.00	<1.00	<1.00	<1.00		
TGSC-1G	2.04	<1.00	<1.00	0.700	<1.00	<1.00	<1.00	<1.00	<1.00	<1.00	<1.00	<1.00	<1.00		
TGSC-1G	2.04	<1.00	0.275	0.965	<1.00	<1.00	<1.00	<1.00	<1.00	<1.00	<1.00	<1.00	<1.00		
Average	2.04	<1.00	<1.00	0.8	<1.00	<1.00	<1.00	<1.00	<1.00	<1.00	<1.00	<1.00	<1.00		
TGSC-1H	2.86	<1.00	<1.00	<1.00	<1.00	<1.00	<1.00	<1.00	<1.00	<1.00	<1.00	<1.00	<1.00		
TGSC-1H	2.86	<1.00	<1.00	<1.00	<1.00	<1.00	<1.00	<1.00	<1.00	<1.00	<1.00	<1.00	<1.00		
Average	2.86	<1.00	<1.00	<1.00	<1.00	<1.00	<1.00	<1.00	<1.00	<1.00	<1.00	<1.00	<1.00		
TGSC-1I	3.47	<1.00	4.55	7.84	<1.00	<1.00	0.317	<1.00	<1.00	<1.00	<1.00	<1.00	<1.00		
TGSC-1I	3.47	<1.00	4.01	7.35	<1.00	<1.00	<1.00	<1.00	<1.00	<1.00	<1.00	<1.00	<1.00		
Average	3.47	<1.00	4.3	7.6	<1.00	<1.00	<1.00	<1.00	<1.00	<1.00	<1.00	<1.00	<1.00		
TGSC-1S	<1.00	<1.00	4.28	7.02	<1.00	<1.00	0.269	<1.00	<1.00	<1.00	<1.00	<1.00	<1.00		
TGSC-1S	<1.00	<1.00	4.48	5.92	<1.00	<1.00	0.311	<1.00	<1.00	<1.00	<1.00	<1.00	<1.00		
Average	<1.00	<1.00	4.4	6.5	<1.00	<1.00	0.3	<1.00	<1.00	<1.00	<1.00	<1.00	<1.00		
TGSC-X8	<1.00	<1.00	3.94	5.99	<1.00	<1.00	0.310	<1.00	<1.00	<1.00	<1.00	<1.00	<1.00		
TGSC-X8	<1.00	<1.00	5.63	7.23	<1.00	<1.00	0.368	<1.00	<1.00	<1.00	<1.00	<1.00	<1.00		
Average	<1.00	<1.00	4.8	6.6	<1.00	<1.00	0.3	<1.00	<1.00	<1.00	<1.00	<1.00	<1.00		

Notes:
 PCE = tetrachloroethylene; TCE = trichloroethylene; cDCE = cis-1,2-dichloroethylene; IDCE = trans-1,2-dichloroethylene; VC = vinyl chloride;
 CT = carbon tetrachloride; TCM = chloroform; DCM = methylene chloride; CM = methyl chloride; 111-TCA = 1,1,1-trichloroethane;
 cBenzene = chlorobenzene; Benzene = benzene
 All concentrations in ug/L (ppb)
 GEL = General Engineering Laboratories, Inc.

Appendix B-12

8 gpm Steady State Inorganic Data Summary - ADS Laboratory
(12/16/97 at 7.98 gpm)

Sample location	Distance into Cell (ft)	Al	B	Ba	Ca	Cd	Cr	Cu	Fe	Mg	Mn	Na	Ni
TCM-2	0	1.974	0.125	0.015	7.119	0.005	<0.015	<0.024	0.131	1.578	0.093	18.611	<0.027
TGSC-1A	0	0.418	0.178	<0.013	2.119	<0.004	0.024	<0.024	0.653	1.060	0.094	46.945	0.141
TGSC-1B	0.14	0.797	0.169	<0.013	4.049	<0.004	<0.015	<0.024	39.237	0.997	0.337	51.475	<0.027
TGSC-1C	0.32	1.082	0.177	<0.013	5.141	<0.004	<0.015	<0.024	24.553	1.113	0.342	48.201	<0.027
TGSC-1D	0.64	1.520	0.176	<0.013	5.716	<0.004	<0.015	<0.024	10.485	1.180	0.262	43.046	<0.027
TGSC-1E	1.07	1.388	<0.048	<0.013	7.293	<0.004	<0.015	<0.024	12.769	0.852	0.234	9.591	<0.027
TGSC-1F	1.5	2.996	<0.048	<0.013	8.561	0.007	0.071	0.265	75.850	0.929	0.516	5.637	0.036
TGSC-1G	2.04	3.522	<0.048	<0.013	8.168	<0.004	<0.015	<0.024	2.904	0.904	0.134	5.083	<0.027
TGSC-1H	2.86	2.412	<0.048	<0.013	6.024	<0.004	<0.015	<0.024	3.932	0.790	0.109	3.688	<0.027
TGSC-1I	3.47	2.182	0.058	<0.013	6.651	<0.004	<0.015	<0.024	0.992	1.198	0.123	14.180	<0.027
TGSC-1S	-	4.188	0.056	<0.013	5.723	<0.004	<0.015	<0.024	3.526	1.010	0.155	10.684	<0.027
TGSC-X8	-	12.265	0.053	<0.013	3.556	<0.004	<0.015	<0.024	3.446	0.954	0.162	9.577	<0.027

Sample location	Distance into Cell (ft)	P	Si	Sr	Zn	Chloride	Fluoride	Formate	Nitrate	Nitrite	Sulfate	Alkalinity
TCM-2	0	0.041	4.844	0.022	0.060	6.0	<0.2	<1	<1	<1	11.0	53
TGSC-1A	0	0.081	6.870	<0.006	0.037	6.0	<0.2	<1	<1	<1	11.0	54
TGSC-1B	0.14	0.030	4.913	0.007	0.037	11.0	<0.2	<1	<1	<1	24.0	105
TGSC-1C	0.32	0.030	4.627	0.008	0.067	9.0	<0.2	<1	<1	<1	15.0	109
TGSC-1D	0.64	0.031	4.145	0.011	0.037	8.0	<0.2	<1	<1	<1	9.0	122
TGSC-1E	1.07	0.036	3.142	0.014	0.047	4.0	<0.2	<1	<1	<1	0.3	80
TGSC-1F	1.5	0.079	2.370	0.016	0.058	3.0	<0.2	<1	<1	<1	<0.5	63
TGSC-1G	2.04	0.039	0.483	0.016	0.050	0.2	<0.2	<1	<1	<1	<0.5	43
TGSC-1H	2.86	0.036	0.775	0.015	0.032	3.0	<0.2	<1	<1	<1	<0.5	42
TGSC-1I	3.47	0.030	0.351	0.019	0.044	5.0	<0.2	<1	<1	<1	2.0	74
TGSC-1S	-	0.030	0.826	0.016	0.042	4.0	<0.2	<1	<1	<1	2.0	79
TGSC-X8	-	<0.025	0.966	0.014	0.031	4.0	<0.2	<1	<1	<1	2.0	53

Notes:

- 1) All units in mg/L
 - 2) Only parameters which had at least one analysis above detection at any of the steady state flow rates are shown in the table.
 - 3) The following parameters were all below their respective detection limits:
Ag (<0.036); Co (<0.021); La (<0.040); Li (<0.018); Mo (<0.017); Pb (<0.076); Sn (<0.027); Ti (<0.017); V (<0.020); Zr (<0.048); Oxalate (<1); Phosphate (<1)
- ADS = SRTC Analytical Development Section

Appendix B-13

8 gpm Steady State Inorganic Data Summary - GEL Laboratory
(12/16/97 at 7.98 gpm)

Sample Location	Distance Into Cell (ft)	Sample Type	Al mg/L	Ca mg/L	Fe mg/L	Si mg/L	Zn mg/L	Gross Alpha PCL	Chloride mg/L	Nitrate/Nitrite mg/L	Sulfate mg/L	Alkalinity mg/L	TSS mg/L	TOC mg/L	BOD5 mg/L
TCM-2	up stream	sample	0.107	4.160	0.047	11.100	0.008	6.24	5.770	8.700	12.300	<5.000	<2.000	1.240	<3.00
TCM-2	up stream	duplicate	0.106	4.100	0.039	11.000	0.008	6.65	5.490	9.000	10.700	<5.000	<2.000	14.800	<3.00
Average	up stream		0.107	4.130	0.043	11.050	0.008		5.630	8.850	11.500	<5.000	<2.000	8.020	<3.00
TGSC-1S	down stream	sample	<0.050	3.800	4.670	2.370	0.002	0.613	4.120	0.030	2.120	37.000	5.600	1.630	3.00
TGSC-1S	down stream	replicate	-	-	-	-	-	-	4.160	-	2.110	36.000	-	-	-
TGSC-1S	down stream	duplicate	<0.050	3.970	4.000	2.080	<0.005	0.499	4.090	0.010	2.110	48.000	1.460	4.400	3.00
Average	down stream		<0.050	3.885	4.335	2.225	<0.005		4.123	0.020	2.113	40.333	3.530	3.015	3.000
TGSC-X8	down stream	sample	<0.050	3.930	2.760	1.850	0.001	0.870	4.050	0.010	1.760	32.600	4.200	1.680	4.00
TGSC-X8	down stream	duplicate	<0.050	3.960	3.030	1.970	0.001	1.2.16	4.030	0.010	1.690	35.500	4.400	2.000	2.00
TGSC-X8	down stream	replicate	-	-	-	-	-	1.67	-	-	-	-	-	-	2.00
Average	down stream		<0.050	3.945	2.895	1.910	0.001		4.040	0.010	1.725	34.050	4.300	1.840	2.667

Notes:
GEL = General Engineering Laboratories, Inc.

8 gpm Testing - Field Data Summary

Sample Location	Distance into Cell (ft)	Organization	ERT	ERT	ERT	ERT	ERT
		Date	11/18/97	11/25/97	12/2/97	12/9/97	12/16/97
		Time	8:25 - 10:55	8:25 - 9:45	8:10 - 9:40	13:23 - 14:55	8:52 - 9:49
		Flow (gpm)	8.05	7.80	7.68	7.89	7.98
		Parameter					

Sample Location	Distance into Cell (ft)	Parameter	ERT	ERT	ERT	ERT	ERT
TCM-2	0	pH	NA	NA	5.77	NA	5.45
TGSC-1A	0	pH	5.77	6.41	6.57	6.07	6.08
TGSC-1B	0.14	pH	6.82	6.9	7.33	7.06	7.18
TGSC-1C	0.32	pH	7.26	7.17	7.32	7.14	7.21
TGSC-1D	0.64	pH	7.58	7.36	7.27	7.3	7.49
TGSC-1E	1.07	pH	7.21	7.19	7.32	7.1	7.21
TGSC-1F	1.5	pH	7.3	6.99	7.21	7.06	7.32
TGSC-1G	2.04	pH	7.17	6.84	7.17	7.05	7.24
TGSC-1H	2.86	pH	7.05	6.8	6.97	6.89	7.16
TGSC-1I	3.47	pH	8.49	8.98	9.25	8.5	9.03
TGSC-1S	-	pH	7.41	8.17	7.43	7.86	8.65
TGSC-X8	-	pH	7.37	7.59	8.12	7.64	8.83

Sample Location	Distance into Cell (ft)	Parameter	ERT	ERT	ERT	ERT	ERT
TCM-2	0	DO, mg/l	NA	NA	NA	NA	3
TGSC-1A	0	DO, mg/l	NA	NA	NA	NA	2.5
TGSC-1B	0.14	DO, mg/l	NA	NA	NA	NA	2
TGSC-1C	0.32	DO, mg/l	NA	NA	NA	NA	2.4
TGSC-1D	0.64	DO, mg/l	NA	NA	NA	NA	2.4
TGSC-1E	1.07	DO, mg/l	NA	NA	NA	NA	2.6
TGSC-1F	1.5	DO, mg/l	NA	NA	NA	NA	2.4
TGSC-1G	2.04	DO, mg/l	NA	NA	NA	NA	2.4
TGSC-1H	2.86	DO, mg/l	NA	NA	NA	NA	2.7
TGSC-1I	3.47	DO, mg/l	NA	NA	NA	NA	2.3
TGSC-1S	-	DO, mg/l	NA	NA	NA	NA	1
TGSC-X8	-	DO, mg/l	NA	NA	NA	NA	1.1

Sample Location	Distance into Cell (ft)	Parameter	ERT	ERT	ERT	ERT	ERT
TCM-2	0	Eh, mV	NA	NA	393.3	NA	456.6
TGSC-1A	0	Eh, mV	461	457.9	444	442.5	430.8
TGSC-1B	0.14	Eh, mV	93.2	86.2	42.2	29.1	29.2
TGSC-1C	0.32	Eh, mV	9	17.1	-2.1	15.4	31.2
TGSC-1D	0.64	Eh, mV	21.5	33.9	26.5	17.1	18.2
TGSC-1E	1.07	Eh, mV	44.7	60	40.8	40.7	56.8
TGSC-1F	1.5	Eh, mV	-22.6	-8.5	17.3	23.6	62.6
TGSC-1G	2.04	Eh, mV	-75.4	-41.9	-6.1	10.6	50.3
TGSC-1H	2.86	Eh, mV	-47.7	-36.4	-14.1	8.6	46.8
TGSC-1I	3.47	Eh, mV	-76.3	-60.1	-73.8	-25.4	-8.6
TGSC-1S	-	Eh, mV	-25.5	-17.2	25.7	28.7	-11.7
TGSC-X8	-	Eh, mV	21.6	-22.1	-38.3	-31.5	34

Sample Location	Distance into Cell (ft)	Parameter	ERT	ERT	ERT	ERT	ERT
TCM-2	0	Temp. °C	NA	NA	13.9	NA	16.7
TGSC-1A	0	Temp. °C	10	9.9	13.7	15.4	13.3
TGSC-1B	0.14	Temp. °C	10.6	12.5	13.6	14.4	13.7
TGSC-1C	0.32	Temp. °C	11.3	13.6	13.8	15.5	14.2
TGSC-1D	0.64	Temp. °C	11.3	13.6	14.5	16	14.6
TGSC-1E	1.07	Temp. °C	11.5	12.7	15.2	16.2	15
TGSC-1F	1.5	Temp. °C	12.4	12.8	14.8	16.6	14.7
TGSC-1G	2.04	Temp. °C	12.6	13.7	15.1	16.7	15
TGSC-1H	2.86	Temp. °C	12.5	13.2	16	16.4	15.3
TGSC-1I	3.47	Temp. °C	12.8	13.5	11.9	16.4	14.5
TGSC-1S	-	Temp. °C	12.5	14.7	14.1	16	16
TGSC-X8	-	Temp. °C	13.8	13.5	13.2	16.7	14.6

Notes: NA = Not analyzed; ERT = SRTC Environmental Restoration Technology Section

Steady State CVOC Data Summary

Sample Location	Distance into Cell (ft)	Laboratory Flow (gpm) Compound	Steady State CVOC Data Summary														
			ERT	ADS	ERT	ERT	ERT - Ave.	ADS	ERT	ERT	ERT - Ave.	ADS	GEL	GEL	GEL - Ave.		
			Date	Date	Date	Date	Date	Date	Date	Date	Date	Date	Date	Date	Date	Date	
			9/30/97	9/30/97	11/11/97	11/11/97	11/11/97	11/11/97	11/11/97	12/16/97	12/16/97	12/16/97	12/16/97	12/16/97	12/16/97	12/16/97	12/16/97
			8:35 - 10:50	8:35 - 10:50	8:35 - 10:32	8:35 - 10:32	8:35 - 10:32	8:35 - 10:32	8:52 - 9:49	8:52 - 9:49	8:52 - 9:49	8:52 - 9:49	8:52 - 9:49	8:52 - 9:49	8:52 - 9:49	8:52 - 9:49	8:52 - 9:49
			0.97	0.97	4.00	4.00	4.00	4.00	7.98	7.98	7.98	7.98	7.98	7.98	7.98	7.98	7.98
TCM-2	0	trichloroethylene	NA	NA	245.7	240.7	243.2	143.7	215.5	222.0	218.8	135.85	206.	234.		220.0	
TGSC-1A	0	trichloroethylene	193.8	156.0	168.1	225.9	197.0	156.1	183.8	190.0	186.9	133.65	158.	163.		160.5	
TGSC-1B	0.14	trichloroethylene	44.7	27.0	157.8	187.6	172.7	158.8	42.3	44.0	43.2	9.45	52.3	56.1		54.2	
TGSC-1C	0.32	trichloroethylene	8.1	5.4	102.3	85.9	94.1	66.9	51.8	55.4	53.6	44.6	45.0	49.1		47.1	
TGSC-1D	0.64	trichloroethylene	ND	<1	44.0	36.7	40.4	27.8	54.8	57.9	56.3	40.3	44.6	46.8		45.7	
TGSC-1E	1.07	trichloroethylene	ND	<1	3.9	3.9	3.9	2.4	28.9	30.8	29.9	20.3	26.0	24.5		25.3	
TGSC-1F	1.5	trichloroethylene	ND	<1	ND	ND	ND	<1	1.0	1.3	1.1	<1	0.950	1.16		1.1	
TGSC-1G	2.04	trichloroethylene	ND	<1	ND	ND	ND	<1	0.3	0.3	0.3	<1	<1.00	0.275		<1.00	
TGSC-1H	2.86	trichloroethylene	ND	<1	ND	ND	ND	<1	0.2	0.2	0.2	<1	<1.00	<1.00		<1.00	
TGSC-1I	3.47	trichloroethylene	ND	<1	1.3	1.1	1.2	<1	5.4	5.0	5.2	3.4	4.55	4.01		4.3	
TGSC-1S	-	trichloroethylene	0.2	<1	1.1	1.0	1.0	<1	5.6	5.0	5.3	3.55	4.28	4.48		4.4	
TGSC-X8	-	trichloroethylene	ND	<1	1.0	1.0	1.0	<1	5.2	4.5	4.8	3.5	3.94	5.63		4.8	
TCM-2	0	cis-1,2-dichloroethylene	NA	NA	38.0	23.2	30.6	24.1	26.0	26.4	26.2	21.35	36.6	37.5		37.1	
TGSC-1A	0	cis-1,2-dichloroethylene	27.9	22.0	32.5	24.8	26.7	25.2	26.0	38.2	32.1	19.55	27.6	27.4		27.5	
TGSC-1B	0.14	cis-1,2-dichloroethylene	<1.0	3.5	28.9	20.2	24.5	22.7	15.3	19.9	17.6	2.15	16.3	17.0		16.7	
TGSC-1C	0.32	cis-1,2-dichloroethylene	ND	3.3	27.7	17.7	22.7	17.8	12.0	12.6	12.3	11.2	15.8	16.6		16.2	
TGSC-1D	0.64	cis-1,2-dichloroethylene	ND	2.6	17.7	12.4	15.0	11.5	22.3	32.0	27.1	11.2	17.1	17.5		17.3	
TGSC-1E	1.07	cis-1,2-dichloroethylene	ND	1.1	ND	ND	ND	2.3	11.9	ND	ND	4.1	8.33	6.38		6.4	
TGSC-1F	1.5	cis-1,2-dichloroethylene	ND	<1	ND	ND	ND	0.8	ND	ND	ND	1.3	1.45	1.72		1.6	
TGSC-1G	2.04	cis-1,2-dichloroethylene	ND	<1	ND	ND	ND	0.4	ND	ND	ND	<1	0.700	0.965		0.8	
TGSC-1H	2.86	cis-1,2-dichloroethylene	ND	<1	ND	ND	ND	0.2	ND	ND	ND	<1	<1.00	<1.00		<1.00	
TGSC-1I	3.47	cis-1,2-dichloroethylene	ND	<1	ND	ND	ND	3.6	9.6	14.0	11.8	5.1	7.84	7.35		7.6	
TGSC-1S	-	cis-1,2-dichloroethylene	ND	<1	ND	ND	ND	2.7	ND	7.7	ND	4.85	7.02	5.92		6.5	
TGSC-X8	-	cis-1,2-dichloroethylene	ND	<1	ND	ND	ND	2.9	ND	7.1	ND	4.55	5.99	7.23		6.6	
TCM-2	0	Carbon Tetrachloride	NA	NA	45.4	24.8	35.1	16.5	23.9	25.5	24.7	18.15	22.5	23.4		23.0	
TGSC-1A	0	Carbon Tetrachloride	29.0	20.0	13.4	12.9	13.2	7	9.2	9.7	9.5	7.75	8.77	8.92		8.8	
TGSC-1B	0.14	Carbon Tetrachloride	ND	<1	0.1	0.1	0.1	<1	ND	ND	ND	<1	<1.00	<1.00		<1.00	
TGSC-1C	0.32	Carbon Tetrachloride	ND	<1	ND	ND	ND	<1	ND	ND	ND	<1	<1.00	<1.00		<1.00	
TGSC-1D	0.64	Carbon Tetrachloride	ND	<1	ND	ND	ND	<1	ND	ND	ND	<1	<1.00	<1.00		<1.00	
TGSC-1E	1.07	Carbon Tetrachloride	ND	<1	ND	ND	ND	<1	ND	ND	ND	<1	<1.00	<1.00		<1.00	
TGSC-1F	1.5	Carbon Tetrachloride	ND	<1	ND	ND	ND	<1	ND	ND	ND	<1	<1.00	<1.00		<1.00	
TGSC-1G	2.04	Carbon Tetrachloride	ND	<1	ND	ND	ND	<1	ND	ND	ND	<1	<1.00	<1.00		<1.00	
TGSC-1H	2.86	Carbon Tetrachloride	ND	<1	ND	ND	ND	<1	ND	ND	ND	<1	<1.00	<1.00		<1.00	
TGSC-1I	3.47	Carbon Tetrachloride	ND	<1	ND	ND	ND	<1	ND	ND	ND	<1	<1.00	<1.00		<1.00	
TGSC-1S	-	Carbon Tetrachloride	ND	<1	ND	ND	ND	<1	ND	ND	ND	<1	<1.00	<1.00		<1.00	
TGSC-X8	-	Carbon Tetrachloride	ND	<1	ND	ND	ND	<1	ND	ND	ND	<1	<1.00	<1.00		<1.00	
TCM-2	0	chloroform	NA	NA	3.5	3.3	3.4	2.7	3.2	3.7	3.4	3.35	3.65	3.78		3.7	
TGSC-1A	0	chloroform	3.1	2.2	6.9	8.1	7.5	6.7	6.2	6.2	6.2	5.95	6.13	6.12		6.1	
TGSC-1B	0.14	chloroform	0.4	<1	6.5	6.9	6.7	6.3	1.4	1.6	1.5	<1	2.22	2.41		2.3	
TGSC-1C	0.32	chloroform	ND	<1	1.7	2.0	1.9	1.8	1.5	1.9	1.7	1.5	1.76	2.06		1.9	
TGSC-1D	0.64	chloroform	ND	<1	0.8	0.9	0.8	0.8	2.4	2.9	2.6	1.9	2.36	2.27		2.3	
TGSC-1E	1.07	chloroform	ND	<1	ND	ND	ND	<1	0.8	1.0	0.9	<1	0.779	0.738		0.8	
TGSC-1F	1.5	chloroform	ND	<1	ND	ND	ND	<1	ND	ND	ND	<1	<1.00	<1.00		<1.00	
TGSC-1G	2.04	chloroform	ND	<1	ND	ND	ND	<1	ND	ND	ND	<1	<1.00	<1.00		<1.00	
TGSC-1H	2.86	chloroform	ND	<1	ND	ND	ND	<1	ND	ND	ND	<1	<1.00	<1.00		<1.00	
TGSC-1I	3.47	chloroform	ND	<1	ND	ND	ND	<1	ND	ND	ND	<1	0.317	<1.00		<1.00	
TGSC-1S	-	chloroform	ND	<1	ND	ND	ND	<1	ND	0.4	ND	<1	0.269	0.311		0.3	
TGSC-X8	-	chloroform	ND	<1	ND	ND	ND	<1	ND	ND	ND	<1	0.310	0.368		0.3	

Notes: NA = Not analyzed; ND = Not detected;
 ERT = SRTC Environmental Restoration Technology Section;
 EBS = SRTC Environmental BioTechnology Section;
 ADS = SRTC Analytical Development Section
 GEL = General Engineering Laboratories, Inc.
 All concentrations in ug/L (ppb)

Steady State Field Data Summary

Sample Location	Distance into Cell (ft)	Organization	ERT		
		Date	9/30/97	11/11/97	12/16/97
		Time	8:35 - 10:50	8:35 - 10:32	8:52 - 9:49
		Flow (gpm)	0.97	4.00	7.98
		Parameter			

TCM-2	0	pH	NA	4.46	5.45
TGSC-1A	0	pH	5.3	5.15	6.08
TGSC-1B	0.14	pH	7.01	6.52	7.18
TGSC-1C	0.32	pH	6.85	6.83	7.21
TGSC-1D	0.64	pH	6.92	6.93	7.49
TGSC-1E	1.07	pH	8.08	6.37	7.21
TGSC-1F	1.5	pH	8.97	6.83	7.32
TGSC-1G	2.04	pH	8.98	7.29	7.24
TGSC-1H	2.86	pH	8.64	6.8	7.16
TGSC-1I	3.47	pH	9.42	9	9.03
TGSC-1S	-	pH	9.52	8.81	8.65
TGSC-X8	-	pH	9.59	8.48	8.83

TCM-2	0	DO, mg/l	NA	3.1	3
TGSC-1A	0	DO, mg/l	4.1	4.2	2.5
TGSC-1B	0.14	DO, mg/l	1.9	2.4	2
TGSC-1C	0.32	DO, mg/l	2	1.9	2.4
TGSC-1D	0.64	DO, mg/l	2	1.9	2.4
TGSC-1E	1.07	DO, mg/l	1.7	2.6	2.6
TGSC-1F	1.5	DO, mg/l	1.9	2.7	2.4
TGSC-1G	2.04	DO, mg/l	1.9	2.3	2.4
TGSC-1H	2.86	DO, mg/l	1.9	2.1	2.7
TGSC-1I	3.47	DO, mg/l	1.9	2.2	2.3
TGSC-1S	-	DO, mg/l	1.2	1.7	1
TGSC-X8	-	DO, mg/l	1.4	1.6	1.1

TCM-2	0	Eh, mV	NA	453.1	456.6
TGSC-1A	0	Eh, mV	NA	316.3	430.8
TGSC-1B	0.14	Eh, mV	NA	71.4	29.2
TGSC-1C	0.32	Eh, mV	NA	-1.1	31.2
TGSC-1D	0.64	Eh, mV	NA	7.1	18.2
TGSC-1E	1.07	Eh, mV	NA	-12.1	56.8
TGSC-1F	1.5	Eh, mV	NA	-85.2	62.6
TGSC-1G	2.04	Eh, mV	NA	-121.3	50.3
TGSC-1H	2.86	Eh, mV	NA	-166.7	46.8
TGSC-1I	3.47	Eh, mV	NA	-129.3	-8.6
TGSC-1S	-	Eh, mV	NA	-140.2	-11.7
TGSC-X8	-	Eh, mV	NA	-74.3	34

TCM-2	0	Temp. °C	NA	16.8	16.7
TGSC-1A	0	Temp. °C	16.8	12.2	13.3
TGSC-1B	0.14	Temp. °C	17.6	13.4	13.7
TGSC-1C	0.32	Temp. °C	17.8	14.4	14.2
TGSC-1D	0.64	Temp. °C	17.6	14.4	14.6
TGSC-1E	1.07	Temp. °C	18	14.3	15
TGSC-1F	1.5	Temp. °C	18.5	14.3	14.7
TGSC-1G	2.04	Temp. °C	19	15.6	15
TGSC-1H	2.86	Temp. °C	19.3	14.8	15.3
TGSC-1I	3.47	Temp. °C	19.5	14.5	14.5
TGSC-1S	-	Temp. °C	20.6	16	16
TGSC-X8	-	Temp. °C	19.8	15.2	14.6

Notes: NA = Not analyzed; ERT = SRTC Environmental Restoration Technology Section

APPENDIX C**FIRST ORDER RATE CONSTANTS**

Appendix C-1, Laboratory Column Test First Order Rate Constant

Appendix C-2, 1 gpm First Order Rate Constant (9/30/97 Steady State Sampling Event at 0.97 gpm)

Appendix C-3, 4 gpm First Order Rate Constant (11/11/97 Steady State Sampling Event at 4.00 gpm)

Appendix C-4, 8 gpm First Order Rate Constant (12/16/97 Steady State Sampling Event at 7.98 gpm)

Appendix C-5, 7.68 gpm First Order Rate Constant (12/2/97 Sampling Event at 7.68 gpm)

Appendix C-1

Laboratory Column Test First Order Rate Constant (k)
(EnviroMetal Technologies, Inc. Data)

Sample Port Distance in Column (cm)	Time to Sample Port (hrs)	ETI			
		TCE			
		(ug/l)	Ln (C/Co)	x	y
0	-1.01394	161	0		
10	0	161	0	0	0
14	0.405577	101	-0.46628	0.5	-0.9325
18	0.811153	76	-0.75067	1	-1.865
26	1.622307	18	-2.19103	1.5	-2.7975
34	2.43346	1.6	-4.6114	2	-3.73
42	3.244613	1.6	-4.6114	2.5	-4.6625
58	4.86692	1.6	-4.6114		
74	6.489227	1.6	-4.6114		
100	9.125475	1.6	-4.6114		

Slope	-1.86513
r squared	0.949311

Slope = Negative of the first order rate constant	
First order rate constant =	1.865

Appendix C-2

1 gpm First Order Rate Constant (k)
(9/30/97 Steady State Sampling Event at 0.97 gpm)

Sample Port Designation	Sample Port Distance in Cell (ft)	Time to Sample Port (min)	Time to Sample Port (hrs)	ADS		EST		Average		
				Ln (C/Co)	x	(ug/L)	Ln (C/Co)	x	TCE	TCE
TGSC-1A	0	0.00	0.00	156.0	0.000	193.8	0.000	-0.016	0	-0.054
TGSC-1B	0.14	252.78	4.21	27.0	-1.754	44.7	-1.467	-1.704	5	-1.789
TGSC-1C	0.32	564.56	9.41	5.4	-3.363	8.1	-3.179	-3.391	10	-3.524
TGSC-1D	0.64	1082.07	18.03	<1		ND		-4.066	12	-4.218
TGSC-1E	1.07	1703.40	28.39	<1		ND				
TGSC-1F	1.5	2239.77	37.33	<1		ND				
TGSC-1G	2.04	2793.03	46.55	<1		ND				
TGSC-1H	2.86	3376.97	56.28	<1		ND				
TGSC-1I	3.47	3610.98	60.18	<1		ND				

Slope	-0.356
r squared	0.993
Intercept	-0.091

Slope	-0.337
r squared	1.000
Intercept	-0.016

Slope = Negative of the first order rate constant	
Average first order rate constant =	0.347
Average intercept =	-0.054

4 gpm First Order Rate Constant (k)
(11/1/97 Steady State Sampling Event at 4.00 gpm)

Sample Port Designation	Sample Port Distance in Cell (ft)	Average Time to Sample Port (min)	Average Time to Sample Port (hrs)	ADS TCE		EST TCE		EST - Duplicate TCE		Average TCE							
				Ln (C/Co)	x	Ln (C/Co)	x	Ln (C/Co)	x	y	x	y	x	y			
TGSC-1A	0	0.00	0.00	156.1	0.000	0.438	0	168.1	-0.295	0	0.151	225.9	0.000	0	0.303	0	0.297
TGSC-1B	0.14	61.53	1.03	158.8	0.017	-0.172	1	157.8	-0.359	1	-0.389	187.6	-0.186	1	-0.282	1	-0.281
TGSC-1C	0.32	137.42	2.29	66.9	-0.847	-1.393	3	102.3	-0.793	3	-1.469	85.9	-0.967	3	-1.450	3	-1.437
TGSC-1D	0.64	263.39	4.39	27.8	-1.725	-2.614	5	44.0	-1.636	5	-2.548	36.7	-1.817	5	-2.619	5	-2.593
TGSC-1E	1.07	414.63	6.91	2.4	-4.175	-4.445	8	3.9	-4.053	8	-4.167	3.9	-4.057	8	-4.372	8	-4.327
TGSC-1F	1.5	545.19	9.09	<1	ND	ND		ND	ND		ND	ND	ND		ND		
TGSC-1G	2.04	679.86	11.33	<1	ND	ND		ND	ND		ND	ND	ND		ND		
TGSC-1H	2.86	822.00	13.70	<1	ND	ND		ND	ND		ND	ND	ND		ND		
TGSC-1I	3.47	878.96	14.65	<1				1.3				1.1					

Slope	-0.610
r squared	0.945
Intercept	0.438

Slope	-0.540
r squared	0.913
Intercept	0.151

Slope	-0.584
r squared	0.962
Intercept	0.303

Slope = Negative of the first order rate constant	
Average first order rate constant =	0.578
Average intercept =	0.297

8 gpm First Order Rate Constant (k)
(12/16/97 Steady State Sampling Event at 7.98 gpm)

Sample Port Designation	Sample Port Distance in Cell (ft)	Average Time to Sample Port (min)	Average Time to Sample Port (hrs)	ADS			EST			EST - Duplicate					
				TCE			TCE			TCE					
				(ug/L)	Ln (C/Co)	x y	(ug/L)	Ln (C/Co)	x y	(ug/L)	Ln (C/Co)	x y			
TGSC-1A	0	0.00	0.00	133.65	0.000	0	-0.579	183.8	0.000	0	0.050	190.0	0.000	0	0.056
TGSC-1B	0.14	30.84	0.51	9.45	-2.649	1	-1.274	42.3	-1.468	1	-0.962	44.0	-1.462	1	-0.941
TGSC-1C	0.32	68.88	1.15	44.6	-1.097	2	-1.969	51.8	-1.266	2	-1.974	55.4	-1.232	2	-1.938
TGSC-1D	0.64	132.03	2.20	40.3	-1.199	3	-2.664	54.8	-1.211	3	-2.986	57.9	-1.189	3	-2.935
TGSC-1E	1.07	207.83	3.46	20.3	-1.885	4	-3.359	28.9	-1.848	4	-3.998	30.8	-1.819	4	-3.932
TGSC-1F	1.5	273.28	4.55	1	-4.895	5	-4.054	1.0	-5.202	5	-5.010	1.3	-5.015	5	-4.929
TGSC-1G	2.04	340.78	5.68	< 1		6	-4.749	0.3	-6.474	6	-6.022	0.3	-6.409	6	-5.926
TGSC-1H	2.86	412.03	6.87	< 1		7	-5.444	0.2	-6.846	7	-7.034	0.2	-6.768	7	-6.923
TGSC-1I	3.47	440.58	7.34	3.4				5.4				5.0			

Slope	-0.695
r squared	0.529
Intercept	-0.579

Slope	-1.012
r squared	0.890
Intercept	0.050

Slope	-0.997
r squared	0.891
Intercept	0.056

Sample Port Designation	Sample Port Distance in Cell (ft)	Average Time to Sample Port (min)	Average Time to Sample Port (hrs)	GEL			GEL - Duplicate			Average			
				TCE			TCE			TCE			
				(ug/L)	Ln (C/Co)	x y	(ug/L)	Ln (C/Co)	x y	x	y		
TGSC-1A	0	0.00	0.00	158.	0.000	0	-0.054	163.	0.000	0	0.178	0	-0.070
TGSC-1B	0.14	30.84	0.51	52.3	-1.106	1	-0.914	56.1	-1.067	1	-0.846	1	-0.987
TGSC-1C	0.32	68.88	1.15	45.0	-1.256	2	-1.774	49.1	-1.200	2	-1.870	2	-1.904
TGSC-1D	0.64	132.03	2.20	44.6	-1.265	3	-2.634	46.8	-1.248	3	-2.894	3	-2.821
TGSC-1E	1.07	207.83	3.46	26.0	-1.804	4	-3.494	24.5	-1.895	4	-3.918	4	-3.738
TGSC-1F	1.5	273.28	4.55	0.950	-5.114	5	-4.354	1.16	-4.945	5	-4.942	5	-4.655
TGSC-1G	2.04	340.78	5.68	<1.00		6	-5.214	0.275	-6.385	6	-5.966	6	-5.572
TGSC-1H	2.86	412.03	6.87	<1.00		7	-6.074	<1.00		7	-6.990	7	-6.489
TGSC-1I	3.47	440.58	7.34	4.55				4.01					

Slope	-0.860
r squared	0.758
Intercept	-0.054

Slope	-1.024
r squared	0.872
Intercept	0.178

Slope = Negative of the first order rate constant	
Average first order rate constant =	0.917
Average intercept =	-0.070

Flow rate (Q) versus first order rate constant (k):

Q (gpm)	k (1/hr)	x	y
---------	----------	---	---

0.97	0.346558	0	0.262
4	0.578	4	0.590
7.98	0.917427	8	0.918

Slope	0.082
r squared	0.999
Intercept	0.262

Appendix C-5

7.68 gpm First Order Rate Constant (k)
(12/2/97 Sampling Event at 7.68 gpm)

Sample Port Designation	Sample Port Distance in Cell (ft)	Average Time to Sample Port (min)	Average Time to Sample Port (hrs)	EST		EST - Duplicate		Average				
				Ln (C/Co)	x	Ln (C/Co)	x	Ln (C/Co)	x	Ln (C/Co)	x	
TGSC-1A	0	0.00	0.00	181.9	0.000	0.315	205.6	0.000	0	0.369	0	0.342
TGSC-1B	0.14	32.05	0.53	101.0	-0.589	-0.505	109.2	-0.633	1	-0.508	1	-0.507
TGSC-1C	0.32	71.57	1.19	86.9	-0.739	-1.325	80.7	-0.935	2	-1.386	2	-1.356
TGSC-1D	0.64	137.18	2.29	85.2	-0.758	-2.145	84.5	-0.889	3	-2.262	3	-2.205
TGSC-1E	1.07	215.95	3.60	60.6	-1.099	-2.965	33.7	-1.809	4	-3.139	4	-3.054
TGSC-1F	1.5	283.95	4.73	1.2	-5.055	-3.785	1.3	-5.077	5	-4.016	5	-3.903
TGSC-1G	2.04	354.09	5.90	<1		<1						
TGSC-1H	2.86	428.12	7.14	<1		<1						
TGSC-1I	3.47	457.79	7.63	5.2			6.9					

Slope	-0.820
r squared	0.672
Intercept	0.315

Slope	-0.877
r squared	0.783
Intercept	0.246

Slope = Negative of the first order rate constant	
Average first order rate constant =	0.849
Average intercept =	0.281

Flow rate (Q) versus first order rate constant (k):

Q (gpm)	k (1/hr)	x	y
0.97	0.347	0	0.267
4	0.578	2	0.425
7.68	0.849	4	0.583
7.98	0.917	8	0.899

Slope	0.079
r squared	0.995
Intercept	0.267

APPENDIX D

**ENVIROMETAL TECHNOLOGIES, INC. (ETI)
LONG TERM PERFORMANCE ISSUES LETTER**



envirometal
technologies
inc.

24 October 1997

Mr. Mark Phifer
Westinghouse Savannah River Company
Savannah River Technology Center
Aiken, SC 29808

**Reference: Long Term Performance of Iron Treatment Systems for VOC Removal,
as Related to the Performance of the TNX GeoSiphon - 31054.30**

Dear Mark:

Further to our recent conversations, we have prepared the following description of our findings to date regarding long term performance issues related to granular iron treatment zones. We have also attempted to relate these results to the ongoing operation of the GeoSiphon at the TNX area, specifically to the observation of sludge formation in the interior (bottom) of the central well and precipitates on the well pump. It is our understanding that these precipitates were noticed following an increase in system pumping rate from 1 gpm to 4 gpm earlier this month.

1.0 Summary of Findings to Date from In-Situ Treatment Systems

As described in previous correspondence, the issue of long term performance in granular iron treatment systems usually focuses on the formation of mineral precipitates, which may cause a decline in hydraulic conductivity and porosity over time. Results to date indicate that the reactivity of the iron should be maintained for several years to decades, even in areas where precipitates occur.

42 Arrow
Guelph, Ontario
Canada N1K 1S6
Tel: (519) 824-0432
Fax: (519) 763-2378

Mineral precipitation is caused by the corrosion of iron in the treatment zone, which will occur as follows:

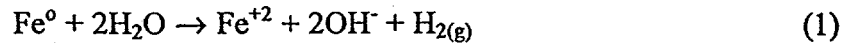

The iron corrosion rate is independent of system flow rates.

A variety of iron precipitates may form in the treatment zone. Iron minerals which form could include iron carbonate (siderite, FeCO_3) and/or iron hydroxides ($\text{Fe}(\text{OH})_2$). Some iron hydroxides may be converted over time to iron oxide (magnetite, Fe_3O_4) (Odziemkowski et.al., in press).

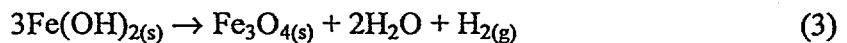

Declines in calcium, magnesium and alkalinity concentrations are expected in response to increasing pH, due to the corrosion of iron (equation 1). As the pH increases, bicarbonate (HCO_3^-) in solution converts to carbonate (CO_3^{2-}) to buffer the pH increase:



The carbonation then combines with cations (Ca^{2+} , Fe^{2+} , Mg^{2+} , etc.) in solution to form mineral precipitates:



Once the carbonate buffering capacity of the groundwater is exhausted, iron hydroxide precipitates will predominate (i.e., at pH's of 8-9 or higher).

In analyses of iron cores obtained from laboratory columns and field sites, both calcite and aragonite, which are polymorphs of calcium carbonate, have been identified. From previous

studies and field applications, it appears that most of the carbonate precipitation occurs in the iron material at the upgradient edge of the treatment wall. This can be expected as the greatest rate of pH increase occurs in the initial portion of the iron. The amount of carbonate precipitate will be dependent on the carbonate content of the groundwater. It has been suggested (Sivavec, 1997) that the predominance of calcite versus siderite may be correlated to the carbonate content of groundwater, although UW researchers have observed little siderite in their examination of field cores.

Aragonite, calcite, iron hydroxide and magnetite have been identified in core samples from pilot-scale permeable reactive barriers in New York and Colorado. No sulphide minerals were observed in University of Waterloo RAMAN spectroscopy examinations, although the elemental sulphur content of the core samples did increase nearer the upgradient interface. Declines in aqueous sulphate concentrations were observed at both sites. Porosity losses in the range of 10% over the first foot of iron were estimated at the Colorado site after 18 months of operation. At the New York site (after two year's operation), the porosity losses in the first few inches was also in the range of 10%, declining sharply over the first foot to below 2%. These porosity losses were calculated based on carbonate analyses of the core material. Given that the original porosity of these systems was on the order of 0.5, it is not expected that flow patterns have been affected. Consistent organic degradation has been observed in both systems since their installation.

Field data gathered to date indicates that buffering by aquifer materials causes upgradient pH and Eh conditions to become re-established in the aquifer within a few feet of travel distance downgradient of the iron wall. At the Elizabeth City site, the pH egressing the iron wall is as high as 10, but appears to return to neutral values within 5 ft of downgradient travel (T. Bennett, R.W. Puls, personal communication, 1997). Eh and pH levels also return to background levels within about 10 ft downgradient of the iron zone at the sites in Colorado and New York. Dissolved iron concentrations egressing systems installed to date are relatively low (<1 mg/L), due to the fact that most of the iron produced due to corrosion precipitates in the treatment zone itself.

Analysis of groundwater and core samples from two different field sites has revealed no evidence of biofouling. Microbial enumerations have resulted in populations very similar to these seen in shallow soils and aquifers (Vogan et.al., in submittal).

2.0 Evaluation of Field Results with Respect to Field Observations at the TNX GeoSiphon

From our recent conversations and the data you provided, we understand that XRD characterization of a sludge sample from the base of the inner pumping well revealed illite, kaolinite, and quartz, as well as pyrite and titanate minerals. During the initial test at 1 gpm, pH values of 9.0 or higher were obtained in the treatment zone (sample ports 1B to 1I); more recent sampling indicates that pH only increases to about 7.0 (ports 1B to 1H) in the iron zone at the higher 4.0 gpm flow rate.

Significant differences exist between the GeoSiphon design and the in-situ treatment systems described above:

- (i) a much shorter system residence time occurs in the GeoSiphon (about 8 hr or 0.33 d at 4 gpm) as compared to 2 to 3 days in other in-situ systems
- (ii) rather than re-entering aquifer sediments, the effluent in the GeoSiphon enters the central well casing, which will likely be a more oxygenated environment than most aquifers downgradient of in-situ systems.
- (iii) from the bench-scale studies, groundwater entering the GeoSiphon likely has much lower calcium (<5 mg/L) and lower alkalinity (<75 mg/L) than most sites where the technology has been applied. Sulphate concentrations are also low (± 9 mg/L).

Given the above discussion, we would suggest the following explanation for observed sludge formation. Given the low carbonate content of the groundwater, calcium carbonate precipitates are not an issue and probably not present to any extent in the sludge or in the reactive material. At the 1 gpm flow rate, residence time (32 hr) was sufficient in the iron to cause pH values to reach ± 9 , causing iron hydroxide, (and siderite) formation in the iron zone itself. However, the shorter residence time at 4 gpm means that pH values do not increase to previous levels, and thus dissolved iron may egress the system, enter the well casing. At this point, especially if slightly more aerobic conditions exist, a variety of (amorphous) iron hydroxide precipitates may form. We also are not surprised at the identification of iron pyrite, based on sulphate declines observed at other sites. As you mentioned, the presence of kaolinite, illite and quartz may be an artifact of system construction. Perhaps the possibility

envirometal technologies inc.

of colloidal transport through the iron, especially at higher flow rates, deserves examination as a source of these clay minerals.

Receipt of inorganic geochemical results from the GeoSiphon (especially major cations and anions) will allow confirmation of these hypotheses. We look forward to your comments on this information, and to discussing these issues further.

Sincerely,

EnviroMetal Technologies Inc.



John Vogan, M.Sc.

Hydrogeologist/Manager

JV/cf

eti\31000\31054\31054-30.lt1

APPENDIX E

**TNX GEOSIPHON CELL EFFLUENT
CERIODAPHNIA DUBIA ACUTE TOXICITY TESTS**



Ceriodaphnia dubia Acute Toxicity Test Data

Reported To: MR. STUART STINSON
WESTINGHOUSE SRS
P.O. BOX 616
BUILDING 735-11A
AIKEN, SC 29808

*Not compliance
sample. X-19 not on line
This represents geosynphon
effluent in proposed phase
of project 1/17/98-4-98*

Sample Description: OUTFALL X-19

Laboratory ID: 127077ST Collected: 1/14/98 1050

Test Date: January 15, 1998 - January 17, 1998

Test Results: No Acute toxicity observed at
the 33 % test concentration.

Pass/Fail: *PASS*

Analyst: BAC

QA/QC By: MAA

Comments: _____

V. Osteen 742-A

CS



NPDES TOXICITY TEST REPORTING FORM - SCDHEC

Facility: WESTINGHOUSE SRS

Sampling Point: OUTFALL X-19

Laboratory: SHEALY ENVIRONMENTAL SERVICES, INC.

Certification Number: 32010

Exp. Date: 03/98

Test Organism: Ceriodaphnia dubia

Temp. Range: 25 ± 1° IWC: 33.00

Date/Time Test Began: 1/15/98 1130

Date/Time Test Ended: 1/17/98 1300

Test Type: (48) hr acute; () day chronic; XXX static ___ daily-renewal

Dilution	Water Source	Alkalinity	Hardness	Conductivity
Moderately	Hard Synthetic Water	64	97	289

Sample Type: (X) Grab () Composite

Control

Day	0	1	2	3	4	5	6	7
Temp	25.1	24.4	24.3					
D.O. Initial	8.00							
D.O. Final		7.60	8.40					
pH Initial	8.05							
pH Final		7.81	7.79					

Effluent - POTW (33%)

Day	0	1	2	3	4	5	6	7
Temp	24.2	24.5	24.4					
D.O. Initial	7.80							
D.O. Final		7.60	8.40					
pH Initial	7.81							
pH Final		7.85	7.87					



MORTALITY / REPRODUCTION DATA

CONTROL			(33.00 %) EFFLUENT		
Rep	Adult (L/D)	# Young	Rep	Adult (L/D)	# Young
1	L		1	L	
2	L		2	L	
3	L		3	L	
4	L		4	L	
5	L		5	L	
6	L		6	L	
7	L		7	L	
8	L		8	L	
9	L		9	L	
10	L		10	L	
11	L		11	L	
12	L		12	L	
13	L		13	L	
14	L		14	L	
15	L		15	L	
16	L		16	L	
17	L		17	L	
18	L		18	L	
19	L		19	L	
20	L		20	L	

TEST RESULTS SUMMARY

Pass/Fail Test Results	% Mortality	Young/Female
Control	0 %	N/A
Test Material	0 %	N/A
Statistical Test	Fisher Exact	N/A
Pass/Fail	PASS	N/A

Principal Analyst (Consultant)
Judy Long 1/23/98
 Signature / Date

Principal Executive Officer (Permittee)

 Signature / Date

Comments (For Departmental Use Only): _____

1/17/98

TOXIS ANALYSIS SUMMARY

Daphnia		Proportion Alive				Day 2
---------	--	------------------	--	--	--	-------

Lab	Species	Date	Test Material	Permit	Protocol	Test Number
SESI	CD	1/15/98	EFF1 (%)	SC0000678	EPAA 91	X-19

Fisher Exact

Transformation	Prop. Conc	Alive	P
No transformation	X 0.00D	1.00	
	X 33.00D	1.00	1.000

NOEC	LOEC	TU	Alpha	Tail	Based on
>33	>33	<3.030	.05	One-sided	Fisher Exact



Ceriodaphnia dubia Acute Toxicity Test Data

Reported To: MR. STUART STINSON
WESTINGHOUSE SRS
P.O. BOX 616
BUILDING 735-11A
AIKEN, SC 29808

*Geosyphon effluent
X-19 not a line
NOT
Compliance Sample
N/D/O 2-4-98*

Sample Description: Outfall X-19

Laboratory ID: 127077T Collected: 1/14/98 1050'

Test Date: January 15, 1998 - January 17, 1998

Test Results: No Acute toxicity observed at the 33 % test concentration.

Pass/Fail: *PASS*

Analyst: JFP

QA/QC By: MSA

Comments: Dilution water sent from Westinghouse SRS. _____

V. Osteen 742-A

45/



NPDES TOXICITY TEST REPORTING FORM - SCDHEC

Facility: WESTINGHOUSE SRS

Sampling Point: Outfall X-19

Laboratory: SHEALY ENVIRONMENTAL SERVICES, INC.

Certification Number: 32010

Exp. Date: 03/98

Test Organism: Ceriodaphnia dubia

Temp. Range: 25 ± 1° IWC: 33.00

Date/Time Test Began: 1/15/98 1415

Date/Time Test Ended: 1/17/98 1310

Test Type: (48) hr acute; () day chronic; XXX static ___ daily-renewal

Dilution Water Source: SRS Dilution Water

Sample Type: (X) Grab () Composite

Control

Day	0	1	2	3	4	5	6	7
Temp	24.8	24.1	24.3					
D.O. Initial	8.00							
D.O. Final		8.10	8.40					
pH Initial	7.85							
pH Final		8.05	8.39					

Effluent - POTW (33%)

Day	0	1	2	3	4	5	6	7
Temp	24.6	24.0	24.3					
D.O. Initial	8.00							
D.O. Final		8.00	8.30					
pH Initial	7.73							
pH Final		8.02	8.08					



MORTALITY / REPRODUCTION DATA

CONTROL			(33.00 %) EFFLUENT		
Rep	Adult (L/D)	# Young	Rep	Adult (L/D)	# Young
1	L		1	L	
2	L		2	L	
3	L		3	L	
4	L		4	L	
5	L		5	L	
6	L		6	L	
7	L		7	L	
8	L		8	L	
9	L		9	L	
10	L		10	L	
11	L		11	L	
12	L		12	L	
13	L		13	L	
14	L		14	L	
15	L		15	L	
16	L		16	L	
17	L		17	L	
18	L		18	L	
19	L		19	L	
20	L		20	L	

TEST RESULTS SUMMARY

Pass/Fail Test Results	% Mortality	Young/Female
Control	0 %	N/A
Test Material	0 %	N/A
Statistical Test	Fisher Exact	N/A
Pass/Fail	PASS	N/A

Principal Analyst (Consultant)

Principal Executive Officer (Permittee)

Judy J. Lang 12/26/98
Signature / Date

Signature / Date

Comments (For Departmental Use Only): _____

Sampler: Print Name: <i>D. STEWART</i>		Sampler Signature: <i>[Signature]</i>				
By my signature I verify addition of required preservatives for all samples listed below.						
Reviewer: Print Name: <i>M. Grace</i>		Reviewer Signature: <i>[Signature]</i>				
DATE		<i>1-14-98</i>	<i>1-14-98</i>	<i>1-14-98</i>	<i>1-14-98</i>	<i>1-14-98</i>
TIME		<i>1050</i>	<i>1400</i>	<i>1100</i>	<i>1300</i>	<i>1350</i>
OUTFALL NO.		<i>X-19</i>	<i>U3R-1A</i>	<i>X-8B</i>	<i>R-01</i>	<i>R-11</i>
GRAB		<i>X</i>	<i>X</i>	<i>✓</i>		
COMP. Start Time					<i>0600</i>	<i>0600</i>
COMP. Start Date					<i>1-13-98</i>	<i>1-13-98</i>
COMP. Stop Time					<i>1300</i>	<i>1330</i>
COMP. Stop Date					<i>1-14-98</i>	<i>1-14-98</i>
# of Containers		<i>2</i>	<i>1</i>	<i>8</i>	<i>1</i>	<i>1</i>
CHRONIC TOXICITY	ICED				<i>✓</i>	<i>✓</i>
O&G	H2SO4		<i>Dilution</i>			
TSS	ICED		<i>Water</i>			
BOD	ICED			<i>✓</i>		
SULFATE	ICED					
AMMONIA (NH3-N)	H2SO4					
NITRATE (NO3)	ICED	<i>1270785</i>	<i>1270785</i>	<i>1270795</i>	<i>1270815</i>	<i>1270825</i>
NITRITE (NO2)	ICED					
PHOSPHOROUS (PO4-P)	H2SO4					
COD	H2SO4					
TOC	H2SO4			<i>✓</i>		
TKN	H2SO4			<i>✓</i>		
PHENOL	H2SO4			<i>✓</i>		
CYANIDE (CN)	NaOH	<i>10MP-1.70</i>			<i>10MP-1.70</i>	<i>10MP-1.70</i>
VOA	ICED					
VOA BLANK	ICED					
BENZENE	HCl			<i>✓</i>		
BENZENE BLANK	HCl			<i>✓</i>		
ARSENIC (AS)	HNO3			<i>1270801B</i>		
CADMIUM (CD)	HNO3					
COPPER (CU)	HNO3					
LEAD (PB)	HNO3					
MANGANESE (MN)	HNO3					
NICKEL (NI)	HNO3					
SILVER (AG)	HNO3					
ZINC (ZN)	HNO3					
ACUTE TOXICITY	ICED	<i>X</i>	<i>SEE COMMENTS</i>		<i>IWC = 33%</i>	
Comments: Run two separate toxicity tests. The first using the U3R-1A water for dilution water. The second test should use your regular lab dilution water.						
Samples REL. by:	<i>[Signature]</i>	Samples REC. by:	<i>[Signature]</i>	Date/Time	<i>01/14/98 1535</i>	
Samples REL. by:	<i>[Signature]</i>	Samples REC. by:	<i>[Signature]</i>	Date/Time	<i>1-14-98 1730</i>	
Samples REL. by:	<i>[Signature]</i>	Samples REC. by:	<i>[Signature]</i>	Date/Time	<i>1-8-98 1104Z</i>	
Samples REL. by:		Samples REC. by:		Date/Time		
Samples to Shealy Env. Services, Contract # AA82244N				Cooler Temperature:		

1/17/98

TOXIS ANALYSIS SUMMARY

Daphnia			Proportion Alive			Day 2
---------	--	--	------------------	--	--	-------

Lab	Species	Date	Test Material	Permit	Protocol	Test Number
SESI	CD	1/15/98	EFF1 (%)	SC0000678	EPAA 91	X19DIAC

Fisher Exact

Transformation	Prop. Conc	Alive	P
No transformation	X 0.00D	1.00	
	X 33.00D	1.00	1.000

NOEC	LOEC	TU	Alpha	Tail	Based on
>33	>33	<3.030	.05	One-sided	Fisher Exact

APPENDIX F
AQTESOLV INPUT & OUTPUT DATA

Appendix F

Input Data							
Elapsed Time (min)	TCM-1 Drawdown (ft)	TNX-11D Drawdown (ft)	TCM-2 Drawdown (ft)	TGSC-1Z Drawdown (ft)	TGSC-1 Drawdown (ft)	Elapsed Time (min)	Flow Rate (cfm)
85	0.0405	0.0811	0.093	0.7798	0.8537	0.001	0.802
100	0.0595	0.0966	0.1049	0.8406	0.9062	1	-0.158
115	0.0691	0.1073	0.118	0.9169	0.9956	3	-0.158
130	0.0786	0.1192	0.1264	0.9634	1.0469	10	0.462
145	0.0881	0.1252	0.1335	0.992	1.0755	15	0.361
160	0.0953	0.13	0.1383	1.0111	1.0874	20	0.393
175	0.0976	0.1347	0.1442	1.0278	1.1005	23	0.440
190	0.0976	0.1383	0.149	1.0397	1.1149	28	0.719
205	0.1072	0.1419	0.1526	1.0492	1.1447	32	0.684
220	0.1072	0.1455	0.1574	1.0564	1.1447	55	0.684
235	0.1096	0.1479	0.1585	1.0635	1.1411	115	0.683
250	0.1143	0.1502	0.1621	1.0683	1.1649	175	0.682
265	0.1154	0.1517	0.1646	1.0724	1.1569	235	0.681
280	0.1133	0.1502	0.1664	1.0762	1.1699	295	0.680
295	0.1149	0.1533	0.1682	1.0795	1.1838	355	0.679
310	0.1219	0.1555	0.1704	1.083	1.1789	415	0.678
325	0.1218	0.159	0.1727	1.0889	1.1824	475	0.677
340	0.1218	0.1614	0.1727	1.0925	1.1872	535	0.676
355	0.1217	0.1626	0.1763	1.0948	1.2015	595	0.675
370	0.1217	0.1638	0.1786	1.0984	1.1871	655	0.674
385	0.1313	0.1673	0.1822	1.102	1.2098	715	0.673
400	0.1313	0.1685	0.1846	1.1044	1.2015	775	0.672
415	0.1313	0.1697	0.187	1.1068	1.2182	835	0.671
430	0.1333	0.1707	0.1879	1.1114	1.2144	895	0.671
445	0.1336	0.1716	0.1897	1.1128	1.2178	955	0.670
460	0.1322	0.1742	0.1886	1.1122	1.217	1015	0.669
475	0.1366	0.1739	0.1882	1.1143	1.2119	1075	0.668
490	0.1364	0.175	0.1916	1.1178	1.2154	1090	0.668
505	0.1364	0.1749	0.1928	1.119	1.2321		
520	0.1363	0.1761	0.194	1.1214	1.2165		
535	0.1363	0.1785	0.1964	1.1238	1.2356		
550	0.1363	0.1797	0.1975	1.1238	1.2261		
565	0.1411	0.1797	0.1975	1.1285	1.2261		
580	0.1363	0.1809	0.1987	1.1285	1.2392		
595	0.1411	0.1821	0.2011	1.1285	1.2392		
610	0.1435	0.1821	0.2011	1.1321	1.2392		
625	0.1387	0.1845	0.2023	1.1333	1.2452		
640	0.1459	0.1845	0.2047	1.1357	1.2559		
655	0.1435	0.1857	0.2059	1.1381	1.244		
670	0.1459	0.188	0.2071	1.1381	1.2595		
685	0.1459	0.188	0.2071	1.1429	1.2428		
700	0.1459	0.1892	0.2071	1.1393	1.2643		
715	0.1459	0.1892	0.2071	1.1429	1.2464		
730	0.1454	0.1901	0.2102	1.1426	1.2484		
745	0.1466	0.1929	0.2105	1.1469	1.2501		

Appendix F

Input Data							
Elapsed Time (min)	TCM-1 Drawdown (ft)	TNX-11D Drawdown (ft)	TCM-2 Drawdown (ft)	TGSC-1Z Drawdown (ft)	TGSC-1 Drawdown (ft)	Elapsed Time (min)	Flow Rate (cfm)
760	0.1436	0.1924	0.21	1.1466	1.2497		
775	0.1519	0.1915	0.2101	1.1472	1.2501		
790	0.1512	0.1911	0.2084	1.1505	1.2569		
805	0.151	0.1921	0.2106	1.1492	1.2675		
820	0.151	0.1956	0.2129	1.1516	1.271		
835	0.1509	0.1956	0.2141	1.1515	1.2627		
850	0.1509	0.1956	0.2129	1.1551	1.2579		
865	0.1533	0.1968	0.2177	1.1551	1.2817		
880	0.1509	0.2004	0.2177	1.1551	1.2627		
895	0.1605	0.2004	0.2177	1.1599	1.265		
910	0.1605	0.2004	0.2177	1.1599	1.2817		
925	0.1605	0.2004	0.22	1.1599	1.2662		
940	0.1605	0.2016	0.2189	1.1599	1.2853		
955	0.1605	0.2004	0.2177	1.1599	1.2734		
970	0.1605	0.2016	0.22	1.1647	1.277		
985	0.1605	0.2004	0.2224	1.1647	1.2698		
1000	0.1652	0.2064	0.2272	1.1647	1.2758		
1015	0.1605	0.2052	0.226	1.1647	1.2758		
1030	0.1629	0.2076	0.2272	1.1659	1.2973		
1045	0.17	0.2088	0.2272	1.1671	1.2996		
1060	0.17	0.2088	0.2284	1.1706	1.2841		
1075	0.1676	0.2088	0.2272	1.1694	1.2996		
1090	0.1676	0.2088	0.2272	1.1694	1.2937		

Appendix F

Output Data: Aqtesolv Curve Match Data							
Elapsed Time (min)	TCM-2 Drawdown (ft)	Elapsed Time (min)	TCM-1 Drawdown (ft)	Elapsed Time (min)	TNX-11D Drawdown (ft)	Elapsed Time (min)	TGSC-1Z Drawdown (ft)
10.0	0.0008	10.0	0.0002	10.0	0.0004	10.0	0.0000
10.4	0.0008	10.1	0.0002	10.1	0.0004	10.1	0.0000
10.8	0.0007	10.2	0.0002	10.2	0.0004	10.2	0.0000
11.3	0.0006	10.3	0.0002	10.3	0.0004	10.3	0.0000
11.8	0.0004	10.4	0.0003	10.4	0.0004	10.4	0.0000
12.2	0.0003	10.5	0.0003	10.5	0.0004	10.5	0.0000
12.8	0.0001	10.6	0.0003	10.6	0.0004	10.6	0.0000
13.3	0.0000	10.7	0.0003	10.7	0.0004	10.7	0.0000
13.8	0.0000	10.8	0.0003	10.8	0.0004	10.8	0.0000
14.4	0.0000	11.0	0.0003	11.0	0.0004	11.0	0.0000
15.0	0.0000	11.1	0.0003	11.1	0.0005	11.1	0.0000
15.4	0.0000	11.2	0.0003	11.2	0.0005	11.2	0.0069
15.9	0.0000	11.3	0.0003	11.3	0.0005	11.3	0.0179
16.4	0.0000	11.4	0.0003	11.4	0.0005	11.4	0.0285
16.8	0.0000	11.5	0.0003	11.5	0.0005	11.5	0.0387
17.3	0.0003	11.6	0.0003	11.6	0.0005	11.6	0.0487
17.8	0.0005	11.8	0.0003	11.8	0.0005	11.8	0.0582
18.3	0.0009	11.9	0.0003	11.9	0.0005	11.9	0.0675
18.9	0.0013	12.0	0.0003	12.0	0.0005	12.0	0.0764
19.4	0.0018	12.1	0.0003	12.1	0.0005	12.1	0.0851
20.0	0.0023	12.2	0.0003	12.2	0.0005	12.2	0.0935
20.3	0.0026	12.4	0.0002	12.4	0.0005	12.4	0.1016
20.6	0.0028	12.5	0.0002	12.5	0.0005	12.5	0.1095
20.9	0.0031	12.6	0.0002	12.6	0.0005	12.6	0.1172
21.1	0.0034	12.8	0.0002	12.8	0.0005	12.8	0.1246
21.4	0.0037	12.9	0.0002	12.9	0.0005	12.9	0.1319
21.7	0.0040	13.0	0.0002	13.0	0.0005	13.0	0.1389
22.1	0.0044	13.1	0.0002	13.1	0.0005	13.1	0.1458
22.4	0.0047	13.3	0.0002	13.3	0.0005	13.3	0.1525
22.7	0.0050	13.4	0.0002	13.4	0.0005	13.4	0.1590
23.0	0.0054	13.6	0.0002	13.6	0.0005	13.6	0.1654
23.5	0.0059	13.7	0.0002	13.7	0.0005	13.7	0.1716
23.9	0.0064	13.8	0.0002	13.8	0.0005	13.8	0.1777
24.4	0.0070	14.0	0.0002	14.0	0.0005	14.0	0.1837
24.9	0.0075	14.1	0.0002	14.1	0.0005	14.1	0.1895
25.4	0.0081	14.3	0.0002	14.3	0.0004	14.3	0.1952
25.9	0.0087	14.4	0.0002	14.4	0.0004	14.4	0.2008
26.4	0.0093	14.6	0.0002	14.6	0.0004	14.6	0.2063
26.9	0.0099	14.7	0.0001	14.7	0.0004	14.7	0.2117
27.5	0.0105	14.8	0.0001	14.8	0.0004	14.8	0.2170
28.0	0.0112	15.0	0.0001	15.0	0.0004	15.0	0.2221
28.4	0.0117	15.1	0.0001	15.1	0.0004	15.1	0.2257
28.8	0.0121	15.2	0.0001	15.2	0.0004	15.2	0.2289
29.1	0.0126	15.3	0.0001	15.3	0.0004	15.3	0.2312
29.5	0.0131	15.4	0.0001	15.4	0.0003	15.4	0.2329

Appendix F

Output Data: Aqtesolv Curve Match Data							
Elapsed Time (min)	TCM-2 Drawdown (ft)	Elapsed Time (min)	TCM-1 Drawdown (ft)	Elapsed Time (min)	TNX-11D Drawdown (ft)	Elapsed Time (min)	TGSC-1Z Drawdown (ft)
29.9	0.0136	15.5	0.0001	15.5	0.0003	15.5	0.2343
30.3	0.0141	15.7	0.0001	15.7	0.0003	15.7	0.2355
30.7	0.0146	15.8	0.0001	15.8	0.0003	15.8	0.2366
31.2	0.0152	15.9	0.0001	15.9	0.0003	15.9	0.2377
31.6	0.0157	16.0	0.0001	16.0	0.0003	16.0	0.2388
32.0	0.0163	16.1	0.0001	16.1	0.0003	16.1	0.2400
32.2	0.0166	16.2	0.0001	16.2	0.0003	16.2	0.2412
32.4	0.0168	16.4	0.0001	16.4	0.0002	16.4	0.2424
32.6	0.0171	16.5	0.0001	16.5	0.0002	16.5	0.2437
32.8	0.0174	16.6	0.0001	16.6	0.0002	16.6	0.2450
33.0	0.0177	16.7	0.0001	16.7	0.0002	16.7	0.2463
33.2	0.0180	16.8	0.0001	16.8	0.0002	16.8	0.2476
33.4	0.0183	17.0	0.0000	17.0	0.0003	17.0	0.2490
33.6	0.0186	17.1	0.0000	17.1	0.0003	17.1	0.2504
33.8	0.0189	17.2	0.0000	17.2	0.0003	17.2	0.2518
34.0	0.0192	17.3	0.0001	17.3	0.0003	17.3	0.2533
34.6	0.0201	17.4	0.0001	17.4	0.0003	17.4	0.2548
35.1	0.0211	17.6	0.0001	17.6	0.0003	17.6	0.2562
35.7	0.0220	17.7	0.0001	17.7	0.0003	17.7	0.2577
36.3	0.0231	17.8	0.0001	17.8	0.0003	17.8	0.2592
36.9	0.0242	18.0	0.0001	18.0	0.0002	18.0	0.2607
37.5	0.0253	18.1	0.0001	18.1	0.0001	18.1	0.2623
38.1	0.0264	18.2	0.0001	18.2	0.0001	18.2	0.2638
38.7	0.0276	18.3	0.0001	18.3	0.0001	18.3	0.2653
39.4	0.0288	18.5	0.0001	18.5	0.0001	18.5	0.2669
40.0	0.0300	18.6	0.0001	18.6	0.0001	18.6	0.2684
41.3	0.0325	18.7	0.0001	18.7	0.0001	18.7	0.2699
42.6	0.0350	18.9	0.0001	18.9	0.0001	18.9	0.2715
44.0	0.0376	19.0	0.0001	19.0	0.0002	19.0	0.2730
45.4	0.0403	19.2	0.0002	19.2	0.0002	19.2	0.2746
46.9	0.0430	19.3	0.0002	19.3	0.0002	19.3	0.2761
48.4	0.0457	19.4	0.0002	19.4	0.0002	19.4	0.2777
50.0	0.0485	19.6	0.0002	19.6	0.0002	19.6	0.2792
51.6	0.0512	19.7	0.0002	19.7	0.0002	19.7	0.2808
53.3	0.0540	19.9	0.0003	19.9	0.0002	19.9	0.2823
55.0	0.0568	20.0	0.0003	20.0	0.0002	20.0	0.2839
56.3	0.0589	20.1	0.0003	20.1	0.0003	20.1	0.2846
57.7	0.0610	20.1	0.0003	20.1	0.0003	20.1	0.2854
59.1	0.0631	20.2	0.0003	20.2	0.0003	20.2	0.2862
60.6	0.0653	20.3	0.0003	20.3	0.0003	20.3	0.2872
62.0	0.0674	20.4	0.0003	20.4	0.0003	20.4	0.2882
63.6	0.0695	20.4	0.0003	20.4	0.0003	20.4	0.2893
65.1	0.0715	20.5	0.0004	20.5	0.0003	20.5	0.2905
66.7	0.0736	20.6	0.0004	20.6	0.0003	20.6	0.2917
68.3	0.0757	20.6	0.0004	20.6	0.0004	20.6	0.2929
70.0	0.0777	20.7	0.0004	20.7	0.0004	20.7	0.2941

Appendix F

Output Data: Aqtesolv Curve Match Data							
Elapsed Time (min)	TCM-2 Drawdown (ft)	Elapsed Time (min)	TCM-1 Drawdown (ft)	Elapsed Time (min)	TNX-11D Drawdown (ft)	Elapsed Time (min)	TGSC-1Z Drawdown (ft)
71.4	0.0794	20.8	0.0004	20.8	0.0004	20.8	0.2952
72.8	0.0810	20.9	0.0004	20.9	0.0004	20.9	0.2964
74.2	0.0827	20.9	0.0004	20.9	0.0004	20.9	0.2976
75.7	0.0843	21.0	0.0005	21.0	0.0005	21.0	0.2988
77.1	0.0859	21.1	0.0005	21.1	0.0005	21.1	0.2999
78.6	0.0875	21.1	0.0005	21.1	0.0005	21.1	0.3011
80.2	0.0891	21.2	0.0005	21.2	0.0005	21.2	0.3022
81.8	0.0907	21.3	0.0005	21.3	0.0005	21.3	0.3034
83.4	0.0923	21.4	0.0005	21.4	0.0006	21.4	0.3045
85.0	0.0938	21.4	0.0006	21.4	0.0006	21.4	0.3056
86.4	0.0951	21.5	0.0006	21.5	0.0006	21.5	0.3067
87.8	0.0964	21.6	0.0006	21.6	0.0006	21.6	0.3078
89.2	0.0977	21.7	0.0006	21.7	0.0006	21.7	0.3089
90.7	0.0990	21.7	0.0006	21.7	0.0007	21.7	0.3099
92.2	0.1003	21.8	0.0006	21.8	0.0007	21.8	0.3110
93.7	0.1015	21.9	0.0007	21.9	0.0007	21.9	0.3120
95.2	0.1028	22.0	0.0007	22.0	0.0008	22.0	0.3131
96.8	0.1040	22.1	0.0007	22.1	0.0008	22.1	0.3141
98.4	0.1053	22.1	0.0007	22.1	0.0008	22.1	0.3151
100.0	0.1065	22.2	0.0007	22.2	0.0008	22.2	0.3162
101.4	0.1076	22.3	0.0008	22.3	0.0009	22.3	0.3172
102.8	0.1086	22.4	0.0008	22.4	0.0009	22.4	0.3182
104.3	0.1096	22.4	0.0008	22.4	0.0009	22.4	0.3192
105.8	0.1107	22.5	0.0008	22.5	0.0010	22.5	0.3202
107.2	0.1117	22.6	0.0008	22.6	0.0010	22.6	0.3212
108.7	0.1127	22.7	0.0009	22.7	0.0010	22.7	0.3221
110.3	0.1137	22.8	0.0009	22.8	0.0011	22.8	0.3231
111.8	0.1147	22.8	0.0009	22.8	0.0011	22.8	0.3241
113.4	0.1157	22.9	0.0009	22.9	0.0011	22.9	0.3250
115.0	0.1167	23.0	0.0010	23.0	0.0012	23.0	0.3260
116.4	0.1176	23.1	0.0010	23.1	0.0012	23.1	0.3273
117.9	0.1185	23.2	0.0010	23.2	0.0013	23.2	0.3289
119.3	0.1193	23.3	0.0011	23.3	0.0013	23.3	0.3308
120.8	0.1202	23.5	0.0011	23.5	0.0014	23.5	0.3330
122.3	0.1210	23.6	0.0011	23.6	0.0015	23.6	0.3353
123.8	0.1218	23.7	0.0012	23.7	0.0015	23.7	0.3377
125.3	0.1227	23.8	0.0012	23.8	0.0016	23.8	0.3400
126.9	0.1235	23.9	0.0012	23.9	0.0016	23.9	0.3424
128.4	0.1243	24.0	0.0013	24.0	0.0017	24.0	0.3446
130.0	0.1252	24.2	0.0013	24.2	0.0018	24.2	0.3469
131.4	0.1259	24.3	0.0014	24.3	0.0018	24.3	0.3491
132.9	0.1266	24.4	0.0014	24.4	0.0019	24.4	0.3512
134.3	0.1273	24.5	0.0015	24.5	0.0020	24.5	0.3533
135.8	0.1280	24.6	0.0015	24.6	0.0021	24.6	0.3554
137.3	0.1288	24.8	0.0015	24.8	0.0021	24.8	0.3574
138.8	0.1295	24.9	0.0016	24.9	0.0022	24.9	0.3594

Appendix F

Output Data: Aqtesolv Curve Match Data							
Elapsed Time (min)	TCM-2 Drawdown (ft)	Elapsed Time (min)	TCM-1 Drawdown (ft)	Elapsed Time (min)	TNX-11D Drawdown (ft)	Elapsed Time (min)	TGSC-1Z Drawdown (ft)
140.3	0.1302	25.0	0.0016	25.0	0.0023	25.0	0.3614
141.9	0.1309	25.1	0.0017	25.1	0.0024	25.1	0.3633
143.4	0.1316	25.3	0.0017	25.3	0.0024	25.3	0.3652
145.0	0.1323	25.4	0.0018	25.4	0.0025	25.4	0.3670
146.4	0.1329	25.5	0.0018	25.5	0.0026	25.5	0.3689
147.9	0.1335	25.6	0.0019	25.6	0.0027	25.6	0.3707
149.3	0.1341	25.8	0.0019	25.8	0.0028	25.8	0.3724
150.8	0.1347	25.9	0.0020	25.9	0.0029	25.9	0.3742
152.3	0.1353	26.0	0.0020	26.0	0.0030	26.0	0.3759
153.8	0.1359	26.1	0.0021	26.1	0.0031	26.1	0.3776
155.3	0.1365	26.3	0.0021	26.3	0.0031	26.3	0.3793
156.9	0.1371	26.4	0.0022	26.4	0.0032	26.4	0.3810
158.4	0.1377	26.5	0.0022	26.5	0.0033	26.5	0.3827
160.0	0.1383	26.7	0.0023	26.7	0.0034	26.7	0.3843
161.4	0.1388	26.8	0.0023	26.8	0.0035	26.8	0.3859
162.9	0.1394	26.9	0.0024	26.9	0.0037	26.9	0.3875
164.4	0.1399	27.1	0.0024	27.1	0.0038	27.1	0.3891
165.8	0.1404	27.2	0.0025	27.2	0.0040	27.2	0.3907
167.3	0.1410	27.3	0.0025	27.3	0.0041	27.3	0.3922
168.8	0.1415	27.5	0.0026	27.5	0.0042	27.5	0.3937
170.4	0.1420	27.6	0.0027	27.6	0.0043	27.6	0.3953
171.9	0.1425	27.7	0.0027	27.7	0.0044	27.7	0.3968
173.4	0.1431	27.9	0.0028	27.9	0.0045	27.9	0.3983
175.0	0.1436	28.0	0.0028	28.0	0.0046	28.0	0.3998
176.4	0.1440	28.1	0.0029	28.1	0.0047	28.1	0.4008
177.9	0.1445	28.2	0.0029	28.2	0.0048	28.2	0.4024
179.4	0.1450	28.3	0.0030	28.3	0.0049	28.3	0.4056
180.9	0.1454	28.4	0.0030	28.4	0.0050	28.4	0.4102
182.3	0.1459	28.5	0.0031	28.5	0.0051	28.5	0.4157
183.9	0.1464	28.6	0.0031	28.6	0.0051	28.6	0.4216
185.4	0.1468	28.7	0.0031	28.7	0.0052	28.7	0.4277
186.9	0.1473	28.8	0.0032	28.8	0.0053	28.8	0.4339
188.4	0.1477	28.9	0.0032	28.9	0.0054	28.9	0.4400
190.0	0.1482	29.0	0.0033	29.0	0.0055	29.0	0.4459
191.4	0.1486	29.0	0.0033	29.0	0.0056	29.0	0.4518
192.9	0.1490	29.1	0.0034	29.1	0.0057	29.1	0.4575
194.4	0.1494	29.2	0.0034	29.2	0.0058	29.2	0.4631
195.9	0.1498	29.3	0.0035	29.3	0.0058	29.3	0.4685
197.4	0.1502	29.4	0.0035	29.4	0.0059	29.4	0.4737
198.9	0.1506	29.5	0.0036	29.5	0.0060	29.5	0.4788
200.4	0.1511	29.6	0.0036	29.6	0.0061	29.6	0.4838
201.9	0.1515	29.7	0.0037	29.7	0.0062	29.7	0.4886
203.4	0.1519	29.8	0.0037	29.8	0.0063	29.8	0.4933
205.0	0.1523	29.9	0.0038	29.9	0.0064	29.9	0.4979
206.5	0.1526	30.0	0.0038	30.0	0.0065	30.0	0.5024
207.9	0.1530	30.1	0.0039	30.1	0.0066	30.1	0.5068

Appendix F

Output Data: Aqtesolv Curve Match Data							
Elapsed Time (min)	TCM-2 Drawdown (ft)	Elapsed Time (min)	TCM-1 Drawdown (ft)	Elapsed Time (min)	TNX-11D Drawdown (ft)	Elapsed Time (min)	TGSC-1Z Drawdown (ft)
209.4	0.1534	30.2	0.0039	30.2	0.0067	30.2	0.5111
210.9	0.1537	30.3	0.0040	30.3	0.0068	30.3	0.5152
212.4	0.1541	30.4	0.0040	30.4	0.0069	30.4	0.5193
213.9	0.1545	30.5	0.0041	30.5	0.0070	30.5	0.5233
215.4	0.1548	30.6	0.0041	30.6	0.0071	30.6	0.5272
216.9	0.1552	30.7	0.0042	30.7	0.0072	30.7	0.5310
218.5	0.1556	30.8	0.0042	30.8	0.0073	30.8	0.5348
220.0	0.1559	30.9	0.0043	30.9	0.0074	30.9	0.5385
221.5	0.1563	31.1	0.0043	31.1	0.0075	31.1	0.5421
222.9	0.1566	31.2	0.0044	31.2	0.0076	31.2	0.5456
224.4	0.1569	31.3	0.0044	31.3	0.0077	31.3	0.5491
225.9	0.1573	31.4	0.0045	31.4	0.0078	31.4	0.5525
227.4	0.1576	31.5	0.0045	31.5	0.0079	31.5	0.5559
228.9	0.1579	31.6	0.0046	31.6	0.0080	31.6	0.5592
230.4	0.1583	31.7	0.0047	31.7	0.0081	31.7	0.5624
231.9	0.1586	31.8	0.0047	31.8	0.0082	31.8	0.5657
233.5	0.1589	31.9	0.0048	31.9	0.0083	31.9	0.5688
235.0	0.1592	32.0	0.0048	32.0	0.0084	32.0	0.5719
236.5	0.1595	32.4	0.0051	32.4	0.0089	32.4	0.5829
237.9	0.1599	32.9	0.0053	32.9	0.0093	32.9	0.5915
239.4	0.1602	33.3	0.0056	33.3	0.0098	33.3	0.5997
240.9	0.1605	33.8	0.0059	33.8	0.0103	33.8	0.6078
242.4	0.1608	34.2	0.0061	34.2	0.0108	34.2	0.6157
243.9	0.1611	34.7	0.0064	34.7	0.0113	34.7	0.6236
245.4	0.1614	35.2	0.0067	35.2	0.0119	35.2	0.6312
246.9	0.1617	35.7	0.0070	35.7	0.0124	35.7	0.6387
248.5	0.1620	36.1	0.0074	36.1	0.0130	36.1	0.6460
250.0	0.1623	36.6	0.0077	36.6	0.0136	36.6	0.6532
251.5	0.1625	37.1	0.0081	37.1	0.0143	37.1	0.6602
252.9	0.1628	37.6	0.0085	37.6	0.0149	37.6	0.6671
254.4	0.1631	38.2	0.0089	38.2	0.0156	38.2	0.6738
255.9	0.1634	38.7	0.0093	38.7	0.0164	38.7	0.6803
257.4	0.1637	39.2	0.0097	39.2	0.0171	39.2	0.6867
258.9	0.1639	39.7	0.0101	39.7	0.0179	39.7	0.6930
260.4	0.1642	40.3	0.0106	40.3	0.0187	40.3	0.6992
261.9	0.1645	40.8	0.0111	40.8	0.0195	40.8	0.7052
263.5	0.1648	41.4	0.0115	41.4	0.0204	41.4	0.7112
265.0	0.1650	42.0	0.0120	42.0	0.0213	42.0	0.7170
266.5	0.1653	42.5	0.0126	42.5	0.0222	42.5	0.7227
267.9	0.1655	43.1	0.0131	43.1	0.0231	43.1	0.7283
269.4	0.1658	43.7	0.0136	43.7	0.0241	43.7	0.7338
270.9	0.1661	44.3	0.0142	44.3	0.0251	44.3	0.7392
272.4	0.1663	44.9	0.0148	44.9	0.0261	44.9	0.7446
273.9	0.1666	45.5	0.0153	45.5	0.0272	45.5	0.7498
275.4	0.1668	46.1	0.0159	46.1	0.0282	46.1	0.7549
276.9	0.1671	46.8	0.0165	46.8	0.0293	46.8	0.7600

Appendix F

Output Data: Aqtesolv Curve Match Data							
Elapsed Time (min)	TCM-2 Drawdown (ft)	Elapsed Time (min)	TCM-1 Drawdown (ft)	Elapsed Time (min)	TNX-11D Drawdown (ft)	Elapsed Time (min)	TGSC-1Z Drawdown (ft)
278.5	0.1673	47.4	0.0172	47.4	0.0304	47.4	0.7650
280.0	0.1676	48.0	0.0178	48.0	0.0315	48.0	0.7699
281.5	0.1678	48.7	0.0185	48.7	0.0327	48.7	0.7748
282.9	0.1681	49.4	0.0191	49.4	0.0338	49.4	0.7795
284.4	0.1683	50.0	0.0198	50.0	0.0350	50.0	0.7843
285.9	0.1685	50.7	0.0205	50.7	0.0362	50.7	0.7889
287.4	0.1688	51.4	0.0211	51.4	0.0374	51.4	0.7935
288.9	0.1690	52.1	0.0219	52.1	0.0386	52.1	0.7980
290.4	0.1693	52.8	0.0226	52.8	0.0398	52.8	0.8024
291.9	0.1695	53.5	0.0233	53.5	0.0410	53.5	0.8068
293.5	0.1697	54.3	0.0240	54.3	0.0422	54.3	0.8111
295.0	0.1700	55.0	0.0248	55.0	0.0435	55.0	0.8154
296.5	0.1702	56.0	0.0258	56.0	0.0452	56.0	0.8211
297.9	0.1704	57.1	0.0268	57.1	0.0469	57.1	0.8267
299.4	0.1706	58.1	0.0279	58.1	0.0486	58.1	0.8322
300.9	0.1709	59.2	0.0289	59.2	0.0504	59.2	0.8376
302.4	0.1711	60.3	0.0300	60.3	0.0521	60.3	0.8429
303.9	0.1713	61.4	0.0311	61.4	0.0539	61.4	0.8482
305.4	0.1715	62.6	0.0322	62.6	0.0556	62.6	0.8533
306.9	0.1717	63.7	0.0333	63.7	0.0574	63.7	0.8584
308.5	0.1720	64.9	0.0345	64.9	0.0591	64.9	0.8634
310.0	0.1722	66.1	0.0356	66.1	0.0608	66.1	0.8683
311.5	0.1724	67.4	0.0367	67.4	0.0626	67.4	0.8732
312.9	0.1726	68.6	0.0379	68.6	0.0643	68.6	0.8780
314.4	0.1728	69.9	0.0391	69.9	0.0661	69.9	0.8827
315.9	0.1730	71.2	0.0402	71.2	0.0678	71.2	0.8873
317.4	0.1732	72.5	0.0414	72.5	0.0695	72.5	0.8919
318.9	0.1734	73.9	0.0426	73.9	0.0712	73.9	0.8964
320.4	0.1736	75.2	0.0438	75.2	0.0729	75.2	0.9009
321.9	0.1738	76.7	0.0449	76.7	0.0746	76.7	0.9053
323.5	0.1740	78.1	0.0461	78.1	0.0763	78.1	0.9096
325.0	0.1743	79.5	0.0473	79.5	0.0780	79.5	0.9139
326.5	0.1745	81.0	0.0485	81.0	0.0796	81.0	0.9181
327.9	0.1746	82.5	0.0497	82.5	0.0812	82.5	0.9222
329.4	0.1748	84.1	0.0509	84.1	0.0829	84.1	0.9263
330.9	0.1750	85.6	0.0521	85.6	0.0845	85.6	0.9303
332.4	0.1752	87.2	0.0533	87.2	0.0861	87.2	0.9343
333.9	0.1754	88.8	0.0545	88.8	0.0877	88.8	0.9382
335.4	0.1756	90.5	0.0557	90.5	0.0892	90.5	0.9421
336.9	0.1758	92.2	0.0569	92.2	0.0908	92.2	0.9459
338.5	0.1760	93.9	0.0580	93.9	0.0923	93.9	0.9497
340.0	0.1762	95.6	0.0592	95.6	0.0938	95.6	0.9534
341.5	0.1764	97.4	0.0604	97.4	0.0953	97.4	0.9571
342.9	0.1766	99.2	0.0616	99.2	0.0968	99.2	0.9607
344.4	0.1768	101.1	0.0628	101.1	0.0983	101.1	0.9643
345.9	0.1770	103.0	0.0639	103.0	0.0997	103.0	0.9678

Appendix F

Output Data: Aqtesolv Curve Match Data							
Elapsed Time (min)	TCM-2 Drawdown (ft)	Elapsed Time (min)	TCM-1 Drawdown (ft)	Elapsed Time (min)	TNX-11D Drawdown (ft)	Elapsed Time (min)	TGSC-1Z Drawdown (ft)
347.4	0.1771	104.9	0.0651	104.9	0.1011	104.9	0.9713
348.9	0.1773	106.8	0.0662	106.8	0.1025	106.8	0.9747
350.4	0.1775	108.8	0.0674	108.8	0.1039	108.8	0.9781
351.9	0.1777	110.8	0.0685	110.8	0.1053	110.8	0.9815
353.5	0.1779	112.9	0.0697	112.9	0.1066	112.9	0.9848
355.0	0.1781	115.0	0.0708	115.0	0.1080	115.0	0.9880
356.5	0.1782	116.2	0.0714	116.2	0.1087	116.2	0.9897
358.0	0.1784	117.4	0.0721	117.4	0.1095	117.4	0.9914
359.4	0.1786	118.7	0.0727	118.7	0.1102	118.7	0.9931
360.9	0.1788	119.9	0.0733	119.9	0.1109	119.9	0.9948
362.4	0.1790	121.2	0.0740	121.2	0.1117	121.2	0.9965
363.9	0.1791	122.5	0.0746	122.5	0.1124	122.5	0.9982
365.4	0.1793	123.8	0.0752	123.8	0.1131	123.8	0.9999
367.0	0.1795	125.1	0.0759	125.1	0.1138	125.1	1.0016
368.5	0.1797	126.4	0.0765	126.4	0.1145	126.4	1.0033
370.0	0.1798	127.7	0.0771	127.7	0.1152	127.7	1.0050
371.5	0.1800	129.1	0.0777	129.1	0.1159	129.1	1.0067
373.0	0.1802	130.4	0.0783	130.4	0.1166	130.4	1.0083
374.4	0.1803	131.8	0.0789	131.8	0.1173	131.8	1.0100
375.9	0.1805	133.2	0.0795	133.2	0.1180	133.2	1.0116
377.4	0.1807	134.6	0.0801	134.6	0.1186	134.6	1.0132
378.9	0.1808	136.0	0.0807	136.0	0.1193	136.0	1.0149
380.4	0.1810	137.5	0.0813	137.5	0.1199	137.5	1.0165
382.0	0.1812	138.9	0.0819	138.9	0.1206	138.9	1.0181
383.5	0.1813	140.4	0.0825	140.4	0.1212	140.4	1.0197
385.0	0.1815	141.9	0.0831	141.9	0.1219	141.9	1.0212
386.5	0.1817	143.4	0.0837	143.4	0.1225	143.4	1.0228
388.0	0.1818	144.9	0.0843	144.9	0.1231	144.9	1.0244
389.4	0.1820	146.4	0.0848	146.4	0.1238	146.4	1.0259
390.9	0.1822	147.9	0.0854	147.9	0.1244	147.9	1.0274
392.4	0.1823	149.5	0.0860	149.5	0.1250	149.5	1.0290
393.9	0.1825	151.1	0.0865	151.1	0.1256	151.1	1.0305
395.4	0.1826	152.7	0.0871	152.7	0.1262	152.7	1.0320
397.0	0.1828	154.3	0.0877	154.3	0.1268	154.3	1.0335
398.5	0.1830	155.9	0.0882	155.9	0.1274	155.9	1.0349
400.0	0.1831	157.6	0.0888	157.6	0.1280	157.6	1.0364
401.5	0.1833	159.2	0.0893	159.2	0.1285	159.2	1.0379
403.0	0.1834	160.9	0.0899	160.9	0.1291	160.9	1.0393
404.4	0.1836	162.6	0.0904	162.6	0.1297	162.6	1.0407
405.9	0.1837	164.3	0.0910	164.3	0.1303	164.3	1.0422
407.4	0.1839	166.1	0.0915	166.1	0.1308	166.1	1.0436
408.9	0.1840	167.8	0.0921	167.8	0.1314	167.8	1.0450
410.4	0.1842	169.6	0.0926	169.6	0.1319	169.6	1.0464
412.0	0.1843	171.4	0.0931	171.4	0.1325	171.4	1.0478
413.5	0.1845	173.2	0.0937	173.2	0.1330	173.2	1.0491
415.0	0.1846	175.0	0.0942	175.0	0.1336	175.0	1.0505

Appendix F

Output Data: Aqtesolv Curve Match Data							
Elapsed Time (min)	TCM-2 Drawdown (ft)	Elapsed Time (min)	TCM-1 Drawdown (ft)	Elapsed Time (min)	TNX-11D Drawdown (ft)	Elapsed Time (min)	TGSC-1Z Drawdown (ft)
416.5	0.1848	176.3	0.0946	176.3	0.1340	176.3	1.0513
418.0	0.1849	177.6	0.0949	177.6	0.1343	177.6	1.0520
419.4	0.1851	178.9	0.0953	178.9	0.1347	178.9	1.0529
420.9	0.1852	180.2	0.0957	180.2	0.1351	180.2	1.0537
422.4	0.1854	181.6	0.0960	181.6	0.1354	181.6	1.0546
423.9	0.1855	182.9	0.0964	182.9	0.1358	182.9	1.0555
425.4	0.1857	184.3	0.0967	184.3	0.1362	184.3	1.0563
427.0	0.1858	185.6	0.0971	185.6	0.1365	185.6	1.0572
428.5	0.1860	187.0	0.0974	187.0	0.1369	187.0	1.0581
430.0	0.1861	188.4	0.0978	188.4	0.1373	188.4	1.0590
431.5	0.1863	189.8	0.0982	189.8	0.1376	189.8	1.0598
433.0	0.1864	191.2	0.0985	191.2	0.1380	191.2	1.0607
434.4	0.1866	192.6	0.0989	192.6	0.1383	192.6	1.0616
435.9	0.1867	194.0	0.0992	194.0	0.1387	194.0	1.0624
437.4	0.1868	195.5	0.0995	195.5	0.1390	195.5	1.0633
438.9	0.1870	196.9	0.0999	196.9	0.1394	196.9	1.0642
440.4	0.1871	198.4	0.1002	198.4	0.1397	198.4	1.0650
442.0	0.1873	199.8	0.1006	199.8	0.1400	199.8	1.0659
443.5	0.1874	201.3	0.1009	201.3	0.1404	201.3	1.0667
445.0	0.1876	202.8	0.1013	202.8	0.1407	202.8	1.0676
446.5	0.1877	204.3	0.1016	204.3	0.1411	204.3	1.0684
448.0	0.1878	205.8	0.1019	205.8	0.1414	205.8	1.0692
449.4	0.1880	207.3	0.1023	207.3	0.1417	207.3	1.0701
450.9	0.1881	208.9	0.1026	208.9	0.1421	208.9	1.0709
452.4	0.1882	210.4	0.1029	210.4	0.1424	210.4	1.0717
453.9	0.1884	212.0	0.1033	212.0	0.1427	212.0	1.0726
455.4	0.1885	213.5	0.1036	213.5	0.1430	213.5	1.0734
457.0	0.1887	215.1	0.1039	215.1	0.1434	215.1	1.0742
458.5	0.1888	216.7	0.1043	216.7	0.1437	216.7	1.0750
460.0	0.1889	218.3	0.1046	218.3	0.1440	218.3	1.0758
461.5	0.1891	219.9	0.1049	219.9	0.1443	219.9	1.0766
463.0	0.1892	221.5	0.1052	221.5	0.1446	221.5	1.0774
464.5	0.1893	223.2	0.1056	223.2	0.1450	223.2	1.0782
465.9	0.1895	224.8	0.1059	224.8	0.1453	224.8	1.0790
467.4	0.1896	226.5	0.1062	226.5	0.1456	226.5	1.0798
468.9	0.1897	228.2	0.1065	228.2	0.1459	228.2	1.0806
470.4	0.1899	229.9	0.1068	229.9	0.1462	229.9	1.0814
472.0	0.1900	231.6	0.1072	231.6	0.1465	231.6	1.0821
473.5	0.1901	233.3	0.1075	233.3	0.1469	233.3	1.0829
475.0	0.1903	235.0	0.1078	235.0	0.1472	235.0	1.0837
476.5	0.1904	236.3	0.1080	236.3	0.1474	236.3	1.0841
478.0	0.1905	237.7	0.1083	237.7	0.1476	237.7	1.0845
479.5	0.1906	239.0	0.1085	239.0	0.1479	239.0	1.0850
480.9	0.1908	240.4	0.1088	240.4	0.1481	240.4	1.0855
482.4	0.1909	241.8	0.1090	241.8	0.1483	241.8	1.0860
483.9	0.1910	243.2	0.1092	243.2	0.1486	243.2	1.0865

Appendix F

Output Data: Aqtesolv Curve Match Data							
Elapsed Time (min)	TCM-2 Drawdown (ft)	Elapsed Time (min)	TCM-1 Drawdown (ft)	Elapsed Time (min)	TNX-11D Drawdown (ft)	Elapsed Time (min)	TGSC-1Z Drawdown (ft)
485.5	0.1912	244.5	0.1095	244.5	0.1488	244.5	1.0870
487.0	0.1913	245.9	0.1097	245.9	0.1490	245.9	1.0876
488.5	0.1914	247.3	0.1100	247.3	0.1493	247.3	1.0881
490.0	0.1916	248.7	0.1102	248.7	0.1495	248.7	1.0887
491.5	0.1917	250.2	0.1104	250.2	0.1497	250.2	1.0892
493.0	0.1918	251.6	0.1107	251.6	0.1500	251.6	1.0897
494.5	0.1919	253.0	0.1109	253.0	0.1502	253.0	1.0903
495.9	0.1921	254.5	0.1111	254.5	0.1504	254.5	1.0908
497.4	0.1922	255.9	0.1114	255.9	0.1506	255.9	1.0914
498.9	0.1923	257.4	0.1116	257.4	0.1509	257.4	1.0919
500.5	0.1924	258.8	0.1118	258.8	0.1511	258.8	1.0924
502.0	0.1926	260.3	0.1121	260.3	0.1513	260.3	1.0930
503.5	0.1927	261.8	0.1123	261.8	0.1515	261.8	1.0935
505.0	0.1928	263.3	0.1125	263.3	0.1518	263.3	1.0940
506.5	0.1929	264.8	0.1127	264.8	0.1520	264.8	1.0946
508.0	0.1930	266.3	0.1130	266.3	0.1522	266.3	1.0951
509.5	0.1932	267.8	0.1132	267.8	0.1524	267.8	1.0956
510.9	0.1933	269.4	0.1134	269.4	0.1527	269.4	1.0962
512.4	0.1934	270.9	0.1137	270.9	0.1529	270.9	1.0967
513.9	0.1935	272.4	0.1139	272.4	0.1531	272.4	1.0972
515.5	0.1937	274.0	0.1141	274.0	0.1533	274.0	1.0977
517.0	0.1938	275.5	0.1143	275.5	0.1535	275.5	1.0983
518.5	0.1939	277.1	0.1146	277.1	0.1538	277.1	1.0988
520.0	0.1940	278.7	0.1148	278.7	0.1540	278.7	1.0993
521.5	0.1941	280.3	0.1150	280.3	0.1542	280.3	1.0998
523.0	0.1943	281.9	0.1152	281.9	0.1544	281.9	1.1003
524.5	0.1944	283.5	0.1155	283.5	0.1546	283.5	1.1009
525.9	0.1945	285.1	0.1157	285.1	0.1549	285.1	1.1014
527.4	0.1946	286.7	0.1159	286.7	0.1551	286.7	1.1019
528.9	0.1947	288.4	0.1161	288.4	0.1553	288.4	1.1024
530.5	0.1949	290.0	0.1163	290.0	0.1555	290.0	1.1029
532.0	0.1950	291.7	0.1166	291.7	0.1557	291.7	1.1034
533.5	0.1951	293.3	0.1168	293.3	0.1559	293.3	1.1039
535.0	0.1952	295.0	0.1170	295.0	0.1562	295.0	1.1044
536.5	0.1953	296.4	0.1172	296.4	0.1563	296.4	1.1046
538.0	0.1954	297.7	0.1174	297.7	0.1565	297.7	1.1049
539.5	0.1956	299.1	0.1175	299.1	0.1567	299.1	1.1052
541.0	0.1957	300.5	0.1177	300.5	0.1569	300.5	1.1055
542.4	0.1958	301.9	0.1179	301.9	0.1570	301.9	1.1058
544.0	0.1959	303.3	0.1181	303.3	0.1572	303.3	1.1062
545.5	0.1960	304.7	0.1182	304.7	0.1574	304.7	1.1065
547.0	0.1961	306.1	0.1184	306.1	0.1576	306.1	1.1069
548.5	0.1963	307.5	0.1186	307.5	0.1577	307.5	1.1073
550.0	0.1964	309.0	0.1188	309.0	0.1579	309.0	1.1076
551.5	0.1965	310.4	0.1190	310.4	0.1581	310.4	1.1080
553.0	0.1966	311.8	0.1191	311.8	0.1582	311.8	1.1084

Appendix F

Output Data: Aqtesolv Curve Match Data							
Elapsed Time (min)	TCM-2 Drawdown (ft)	Elapsed Time (min)	TCM-1 Drawdown (ft)	Elapsed Time (min)	TNX-11D Drawdown (ft)	Elapsed Time (min)	TGSC-1Z Drawdown (ft)
554.5	0.1967	313.3	0.1193	313.3	0.1584	313.3	1.1087
556.0	0.1968	314.7	0.1195	314.7	0.1586	314.7	1.1091
557.5	0.1969	316.2	0.1197	316.2	0.1588	316.2	1.1095
559.0	0.1971	317.7	0.1198	317.7	0.1589	317.7	1.1099
560.5	0.1972	319.2	0.1200	319.2	0.1591	319.2	1.1102
562.0	0.1973	320.6	0.1202	320.6	0.1593	320.6	1.1106
563.5	0.1974	322.1	0.1203	322.1	0.1594	322.1	1.1110
565.0	0.1975	323.6	0.1205	323.6	0.1596	323.6	1.1114
566.5	0.1976	325.1	0.1207	325.1	0.1598	325.1	1.1117
568.0	0.1977	326.6	0.1209	326.6	0.1599	326.6	1.1121
569.5	0.1978	328.1	0.1210	328.1	0.1601	328.1	1.1125
571.0	0.1980	329.7	0.1212	329.7	0.1603	329.7	1.1129
572.5	0.1981	331.2	0.1214	331.2	0.1605	331.2	1.1132
574.0	0.1982	332.7	0.1216	332.7	0.1606	332.7	1.1136
575.5	0.1983	334.3	0.1217	334.3	0.1608	334.3	1.1140
577.0	0.1984	335.8	0.1219	335.8	0.1610	335.8	1.1143
578.5	0.1985	337.4	0.1221	337.4	0.1611	337.4	1.1147
580.0	0.1986	338.9	0.1222	338.9	0.1613	338.9	1.1151
581.5	0.1987	340.5	0.1224	340.5	0.1615	340.5	1.1154
583.0	0.1988	342.1	0.1226	342.1	0.1616	342.1	1.1158
584.5	0.1989	343.7	0.1227	343.7	0.1618	343.7	1.1162
586.0	0.1991	345.3	0.1229	345.3	0.1620	345.3	1.1166
587.5	0.1992	346.9	0.1231	346.9	0.1621	346.9	1.1169
589.0	0.1993	348.5	0.1233	348.5	0.1623	348.5	1.1173
590.5	0.1994	350.1	0.1234	350.1	0.1625	350.1	1.1177
592.0	0.1995	351.7	0.1236	351.7	0.1627	351.7	1.1180
593.5	0.1996	353.4	0.1238	353.4	0.1628	353.4	1.1184
595.0	0.1997	355.0	0.1239	355.0	0.1630	355.0	1.1187
596.5	0.1998	356.4	0.1241	356.4	0.1631	356.4	1.1189
598.0	0.1999	357.8	0.1242	357.8	0.1633	357.8	1.1190
599.5	0.2000	359.2	0.1244	359.2	0.1634	359.2	1.1192
601.0	0.2001	360.6	0.1245	360.6	0.1636	360.6	1.1194
602.5	0.2002	362.0	0.1247	362.0	0.1637	362.0	1.1196
604.0	0.2003	363.4	0.1248	363.4	0.1639	363.4	1.1199
605.5	0.2004	364.8	0.1249	364.8	0.1640	364.8	1.1201
607.0	0.2006	366.3	0.1251	366.3	0.1641	366.3	1.1204
608.5	0.2007	367.7	0.1252	367.7	0.1643	367.7	1.1207
610.0	0.2008	369.1	0.1254	369.1	0.1644	369.1	1.1209
611.5	0.2009	370.6	0.1255	370.6	0.1646	370.6	1.1212
613.0	0.2010	372.0	0.1256	372.0	0.1647	372.0	1.1215
614.5	0.2011	373.5	0.1258	373.5	0.1648	373.5	1.1218
616.0	0.2012	374.9	0.1259	374.9	0.1650	374.9	1.1220
617.5	0.2013	376.4	0.1261	376.4	0.1651	376.4	1.1223
619.0	0.2014	377.9	0.1262	377.9	0.1653	377.9	1.1226
620.5	0.2015	379.4	0.1263	379.4	0.1654	379.4	1.1229
622.0	0.2016	380.8	0.1265	380.8	0.1655	380.8	1.1232

Appendix F

Output Data: Aqtesolv Curve Match Data							
Elapsed Time (min)	TCM-2 Drawdown (ft)	Elapsed Time (min)	TCM-1 Drawdown (ft)	Elapsed Time (min)	TNX-11D Drawdown (ft)	Elapsed Time (min)	TGSC-1Z Drawdown (ft)
623.5	0.2017	382.3	0.1266	382.3	0.1657	382.3	1.1234
625.0	0.2018	383.8	0.1268	383.8	0.1658	383.8	1.1237
626.5	0.2019	385.3	0.1269	385.3	0.1660	385.3	1.1240
628.0	0.2020	386.8	0.1270	386.8	0.1661	386.8	1.1243
629.5	0.2021	388.4	0.1272	388.4	0.1662	388.4	1.1246
631.0	0.2022	389.9	0.1273	389.9	0.1664	389.9	1.1248
632.5	0.2023	391.4	0.1275	391.4	0.1665	391.4	1.1251
634.0	0.2024	392.9	0.1276	392.9	0.1667	392.9	1.1254
635.5	0.2025	394.5	0.1277	394.5	0.1668	394.5	1.1257
637.0	0.2026	396.0	0.1279	396.0	0.1670	396.0	1.1260
638.5	0.2027	397.6	0.1280	397.6	0.1671	397.6	1.1262
640.0	0.2028	399.1	0.1282	399.1	0.1672	399.1	1.1265
641.5	0.2029	400.7	0.1283	400.7	0.1674	400.7	1.1268
643.0	0.2030	402.2	0.1284	402.2	0.1675	402.2	1.1271
644.5	0.2031	403.8	0.1286	403.8	0.1677	403.8	1.1274
646.0	0.2032	405.4	0.1287	405.4	0.1678	405.4	1.1277
647.5	0.2033	407.0	0.1288	407.0	0.1679	407.0	1.1279
649.0	0.2034	408.6	0.1290	408.6	0.1681	408.6	1.1282
650.5	0.2035	410.2	0.1291	410.2	0.1682	410.2	1.1285
652.0	0.2036	411.8	0.1293	411.8	0.1684	411.8	1.1288
653.5	0.2037	413.4	0.1294	413.4	0.1685	413.4	1.1291
655.0	0.2038	415.0	0.1295	415.0	0.1687	415.0	1.1293
656.5	0.2039	416.4	0.1297	416.4	0.1688	416.4	1.1294
658.0	0.2040	417.8	0.1298	417.8	0.1689	417.8	1.1295
659.5	0.2041	419.2	0.1299	419.2	0.1690	419.2	1.1296
661.0	0.2042	420.6	0.1300	420.6	0.1691	420.6	1.1297
662.5	0.2043	422.1	0.1301	422.1	0.1693	422.1	1.1299
664.0	0.2044	423.5	0.1303	423.5	0.1694	423.5	1.1301
665.5	0.2045	424.9	0.1304	424.9	0.1695	424.9	1.1303
667.0	0.2046	426.4	0.1305	426.4	0.1696	426.4	1.1305
668.5	0.2047	427.8	0.1306	427.8	0.1698	427.8	1.1307
670.0	0.2048	429.2	0.1307	429.2	0.1699	429.2	1.1309
671.5	0.2049	430.7	0.1309	430.7	0.1700	430.7	1.1311
673.0	0.2050	432.2	0.1310	432.2	0.1701	432.2	1.1313
674.5	0.2051	433.6	0.1311	433.6	0.1703	433.6	1.1315
676.0	0.2052	435.1	0.1312	435.1	0.1704	435.1	1.1318
677.5	0.2053	436.6	0.1313	436.6	0.1705	436.6	1.1320
679.0	0.2054	438.0	0.1315	438.0	0.1706	438.0	1.1322
680.5	0.2055	439.5	0.1316	439.5	0.1707	439.5	1.1324
682.0	0.2056	441.0	0.1317	441.0	0.1709	441.0	1.1326
683.5	0.2057	442.5	0.1318	442.5	0.1710	442.5	1.1328
685.0	0.2058	444.0	0.1319	444.0	0.1711	444.0	1.1331
686.5	0.2059	445.5	0.1320	445.5	0.1712	445.5	1.1333
688.0	0.2060	447.0	0.1322	447.0	0.1713	447.0	1.1335
689.5	0.2061	448.5	0.1323	448.5	0.1715	448.5	1.1337
691.0	0.2062	450.0	0.1324	450.0	0.1716	450.0	1.1340

Appendix F

Output Data: Aqtesolv Curve Match Data							
Elapsed Time (min)	TCM-2 Drawdown (ft)	Elapsed Time (min)	TCM-1 Drawdown (ft)	Elapsed Time (min)	TNX-11D Drawdown (ft)	Elapsed Time (min)	TGSC-1Z Drawdown (ft)
692.5	0.2063	451.5	0.1325	451.5	0.1717	451.5	1.1342
694.0	0.2064	453.1	0.1326	453.1	0.1718	453.1	1.1344
695.5	0.2065	454.6	0.1328	454.6	0.1720	454.6	1.1346
697.0	0.2066	456.1	0.1329	456.1	0.1721	456.1	1.1349
698.5	0.2067	457.7	0.1330	457.7	0.1722	457.7	1.1351
700.0	0.2068	459.2	0.1331	459.2	0.1723	459.2	1.1353
701.5	0.2069	460.8	0.1332	460.8	0.1725	460.8	1.1355
703.0	0.2069	462.3	0.1333	462.3	0.1726	462.3	1.1358
704.5	0.2070	463.9	0.1335	463.9	0.1727	463.9	1.1360
706.0	0.2071	465.5	0.1336	465.5	0.1728	465.5	1.1362
707.5	0.2072	467.1	0.1337	467.1	0.1729	467.1	1.1364
709.0	0.2073	468.6	0.1338	468.6	0.1731	468.6	1.1367
710.5	0.2074	470.2	0.1339	470.2	0.1732	470.2	1.1369
712.0	0.2075	471.8	0.1341	471.8	0.1733	471.8	1.1371
713.5	0.2076	473.4	0.1342	473.4	0.1734	473.4	1.1373
715.0	0.2077	475.0	0.1343	475.0	0.1736	475.0	1.1376
716.5	0.2078	476.4	0.1344	476.4	0.1737	476.4	1.1376
718.0	0.2079	477.8	0.1345	477.8	0.1738	477.8	1.1376
719.5	0.2080	479.3	0.1346	479.3	0.1739	479.3	1.1377
721.0	0.2081	480.7	0.1347	480.7	0.1740	480.7	1.1378
722.5	0.2082	482.1	0.1348	482.1	0.1741	482.1	1.1379
724.0	0.2083	483.6	0.1349	483.6	0.1742	483.6	1.1381
725.5	0.2084	485.0	0.1350	485.0	0.1743	485.0	1.1382
727.0	0.2084	486.4	0.1351	486.4	0.1745	486.4	1.1384
728.5	0.2085	487.9	0.1352	487.9	0.1746	487.9	1.1386
730.0	0.2086	489.3	0.1353	489.3	0.1747	489.3	1.1387
731.5	0.2087	490.8	0.1354	490.8	0.1748	490.8	1.1389
733.0	0.2088	492.3	0.1355	492.3	0.1749	492.3	1.1391
734.5	0.2089	493.7	0.1356	493.7	0.1750	493.7	1.1392
736.0	0.2090	495.2	0.1358	495.2	0.1751	495.2	1.1394
737.5	0.2091	496.7	0.1359	496.7	0.1752	496.7	1.1396
739.0	0.2092	498.1	0.1360	498.1	0.1753	498.1	1.1398
740.5	0.2093	499.6	0.1361	499.6	0.1754	499.6	1.1400
742.0	0.2094	501.1	0.1362	501.1	0.1755	501.1	1.1401
743.5	0.2095	502.6	0.1363	502.6	0.1757	502.6	1.1403
745.0	0.2096	504.1	0.1364	504.1	0.1758	504.1	1.1405
746.5	0.2096	505.6	0.1365	505.6	0.1759	505.6	1.1407
748.0	0.2097	507.1	0.1366	507.1	0.1760	507.1	1.1409
749.5	0.2098	508.6	0.1367	508.6	0.1761	508.6	1.1411
751.0	0.2099	510.1	0.1368	510.1	0.1762	510.1	1.1412
752.5	0.2100	511.7	0.1369	511.7	0.1763	511.7	1.1414
754.0	0.2101	513.2	0.1370	513.2	0.1764	513.2	1.1416
755.5	0.2102	514.7	0.1371	514.7	0.1765	514.7	1.1418
757.0	0.2103	516.2	0.1372	516.2	0.1766	516.2	1.1420
758.5	0.2104	517.8	0.1373	517.8	0.1768	517.8	1.1422
760.0	0.2105	519.3	0.1374	519.3	0.1769	519.3	- 1.1424

Appendix F

Output Data: Aqtesolv Curve Match Data							
Elapsed Time (min)	TCM-2 Drawdown (ft)	Elapsed Time (min)	TCM-1 Drawdown (ft)	Elapsed Time (min)	TNX-11D Drawdown (ft)	Elapsed Time (min)	TGSC-1Z Drawdown (ft)
761.5	0.2105	520.9	0.1375	520.9	0.1770	520.9	1.1425
763.0	0.2106	522.4	0.1376	522.4	0.1771	522.4	1.1427
764.5	0.2107	524.0	0.1377	524.0	0.1772	524.0	1.1429
766.0	0.2108	525.5	0.1378	525.5	0.1773	525.5	1.1431
767.5	0.2109	527.1	0.1379	527.1	0.1774	527.1	1.1433
769.0	0.2110	528.7	0.1380	528.7	0.1775	528.7	1.1435
770.5	0.2111	530.2	0.1381	530.2	0.1777	530.2	1.1437
772.0	0.2112	531.8	0.1382	531.8	0.1778	531.8	1.1439
773.5	0.2113	533.4	0.1383	533.4	0.1779	533.4	1.1441
775.0	0.2114	535.0	0.1385	535.0	0.1780	535.0	1.1442
776.5	0.2114	536.4	0.1385	536.4	0.1781	536.4	1.1442
778.0	0.2115	537.9	0.1386	537.9	0.1782	537.9	1.1442
779.5	0.2116	539.3	0.1387	539.3	0.1783	539.3	1.1443
781.0	0.2117	540.7	0.1388	540.7	0.1784	540.7	1.1444
782.5	0.2118	542.2	0.1389	542.2	0.1785	542.2	1.1445
784.0	0.2119	543.6	0.1390	543.6	0.1786	543.6	1.1446
785.5	0.2120	545.0	0.1391	545.0	0.1787	545.0	1.1447
787.0	0.2121	546.5	0.1392	546.5	0.1788	546.5	1.1448
788.5	0.2121	547.9	0.1393	547.9	0.1789	547.9	1.1450
790.0	0.2122	549.4	0.1394	549.4	0.1790	549.4	1.1451
791.5	0.2123	550.9	0.1395	550.9	0.1791	550.9	1.1452
793.0	0.2124	552.3	0.1396	552.3	0.1792	552.3	1.1454
794.5	0.2125	553.8	0.1397	553.8	0.1793	553.8	1.1455
796.0	0.2126	555.3	0.1398	555.3	0.1794	555.3	1.1457
797.5	0.2127	556.8	0.1398	556.8	0.1795	556.8	1.1458
799.0	0.2128	558.2	0.1399	558.2	0.1796	558.2	1.1460
800.5	0.2128	559.7	0.1400	559.7	0.1797	559.7	1.1461
802.0	0.2129	561.2	0.1401	561.2	0.1798	561.2	1.1463
803.5	0.2130	562.7	0.1402	562.7	0.1799	562.7	1.1464
805.0	0.2131	564.2	0.1403	564.2	0.1800	564.2	1.1466
806.5	0.2132	565.7	0.1404	565.7	0.1801	565.7	1.1468
808.0	0.2133	567.2	0.1405	567.2	0.1802	567.2	1.1469
809.5	0.2134	568.7	0.1406	568.7	0.1803	568.7	1.1471
811.0	0.2135	570.2	0.1407	570.2	0.1804	570.2	1.1472
812.5	0.2135	571.7	0.1408	571.7	0.1805	571.7	1.1474
814.0	0.2136	573.3	0.1409	573.3	0.1806	573.3	1.1476
815.5	0.2137	574.8	0.1410	574.8	0.1807	574.8	1.1477
817.0	0.2138	576.3	0.1411	576.3	0.1808	576.3	1.1479
818.5	0.2139	577.9	0.1411	577.9	0.1809	577.9	1.1480
820.0	0.2140	579.4	0.1412	579.4	0.1810	579.4	1.1482
821.5	0.2141	580.9	0.1413	580.9	0.1811	580.9	1.1484
823.0	0.2141	582.5	0.1414	582.5	0.1812	582.5	1.1485
824.5	0.2142	584.0	0.1415	584.0	0.1813	584.0	1.1487
826.0	0.2143	585.6	0.1416	585.6	0.1814	585.6	1.1488
827.5	0.2144	587.1	0.1417	587.1	0.1815	587.1	1.1490
829.0	0.2145	588.7	0.1418	588.7	0.1816	588.7	1.1492

Appendix F

Output Data: Aqtesolv Curve Match Data							
Elapsed Time (min)	TCM-2 Drawdown (ft)	Elapsed Time (min)	TCM-1 Drawdown (ft)	Elapsed Time (min)	TNX-11D Drawdown (ft)	Elapsed Time (min)	TGSC-1Z Drawdown (ft)
830.5	0.2146	590.3	0.1419	590.3	0.1817	590.3	1.1493
832.0	0.2147	591.8	0.1420	591.8	0.1818	591.8	1.1495
833.5	0.2147	593.4	0.1421	593.4	0.1819	593.4	1.1497
835.0	0.2148	595.0	0.1422	595.0	0.1821	595.0	1.1498
836.5	0.2149	596.4	0.1423	596.4	0.1821	596.4	1.1498
838.0	0.2150	597.9	0.1423	597.9	0.1822	597.9	1.1498
839.5	0.2151	599.3	0.1424	599.3	0.1823	599.3	1.1498
841.0	0.2152	600.7	0.1425	600.7	0.1824	600.7	1.1499
842.5	0.2152	602.2	0.1426	602.2	0.1825	602.2	1.1499
844.0	0.2153	603.6	0.1427	603.6	0.1826	603.6	1.1500
845.5	0.2154	605.1	0.1428	605.1	0.1827	605.1	1.1501
847.0	0.2155	606.5	0.1429	606.5	0.1828	606.5	1.1502
848.5	0.2156	608.0	0.1429	608.0	0.1829	608.0	1.1504
850.0	0.2157	609.5	0.1430	609.5	0.1830	609.5	1.1505
851.5	0.2157	610.9	0.1431	610.9	0.1831	610.9	1.1506
853.0	0.2158	612.4	0.1432	612.4	0.1832	612.4	1.1507
854.5	0.2159	613.9	0.1433	613.9	0.1833	613.9	1.1508
856.0	0.2160	615.3	0.1434	615.3	0.1834	615.3	1.1510
857.5	0.2161	616.8	0.1434	616.8	0.1835	616.8	1.1511
859.0	0.2162	618.3	0.1435	618.3	0.1836	618.3	1.1512
860.5	0.2162	619.8	0.1436	619.8	0.1837	619.8	1.1514
862.0	0.2163	621.3	0.1437	621.3	0.1837	621.3	1.1515
863.5	0.2164	622.8	0.1438	622.8	0.1838	622.8	1.1516
865.0	0.2165	624.3	0.1439	624.3	0.1839	624.3	1.1518
866.5	0.2166	625.8	0.1440	625.8	0.1840	625.8	1.1519
868.0	0.2167	627.3	0.1440	627.3	0.1841	627.3	1.1520
869.5	0.2167	628.8	0.1441	628.8	0.1842	628.8	1.1522
871.0	0.2168	630.3	0.1442	630.3	0.1843	630.3	1.1523
872.5	0.2169	631.8	0.1443	631.8	0.1844	631.8	1.1525
874.0	0.2170	633.3	0.1444	633.3	0.1845	633.3	1.1526
875.5	0.2171	634.9	0.1445	634.9	0.1846	634.9	1.1527
877.0	0.2172	636.4	0.1445	636.4	0.1847	636.4	1.1529
878.5	0.2172	637.9	0.1446	637.9	0.1848	637.9	1.1530
880.0	0.2173	639.5	0.1447	639.5	0.1849	639.5	1.1532
881.5	0.2174	641.0	0.1448	641.0	0.1850	641.0	1.1533
883.0	0.2175	642.5	0.1449	642.5	0.1851	642.5	1.1534
884.5	0.2176	644.1	0.1450	644.1	0.1852	644.1	1.1536
886.0	0.2176	645.6	0.1451	645.6	0.1853	645.6	1.1537
887.5	0.2177	647.2	0.1451	647.2	0.1854	647.2	1.1539
889.0	0.2178	648.7	0.1452	648.7	0.1855	648.7	1.1540
890.5	0.2179	650.3	0.1453	650.3	0.1855	650.3	1.1542
892.0	0.2180	651.9	0.1454	651.9	0.1856	651.9	1.1543
893.5	0.2181	653.4	0.1455	653.4	0.1857	653.4	1.1545
895.0	0.2181	655.0	0.1456	655.0	0.1858	655.0	1.1546
896.5	0.2182	656.4	0.1457	656.4	0.1859	656.4	1.1545
898.0	0.2183	657.9	0.1457	657.9	0.1860	657.9	1.1545

Appendix F

Output Data: Aqtesolv Curve Match Data							
Elapsed Time (min)	TCM-2 Drawdown (ft)	Elapsed Time (min)	TCM-1 Drawdown (ft)	Elapsed Time (min)	TNX-11D Drawdown (ft)	Elapsed Time (min)	TGSC-1Z Drawdown (ft)
899.5	0.2184	659.3	0.1458	659.3	0.1861	659.3	1.1545
901.0	0.2185	660.8	0.1459	660.8	0.1862	660.8	1.1546
902.5	0.2185	662.2	0.1460	662.2	0.1863	662.2	1.1546
904.0	0.2186	663.7	0.1460	663.7	0.1864	663.7	1.1547
905.5	0.2187	665.1	0.1461	665.1	0.1865	665.1	1.1548
907.0	0.2188	666.6	0.1462	666.6	0.1866	666.6	1.1549
908.5	0.2189	668.0	0.1463	668.0	0.1866	668.0	1.1550
910.0	0.2189	669.5	0.1464	669.5	0.1867	669.5	1.1551
911.5	0.2190	671.0	0.1464	671.0	0.1868	671.0	1.1552
913.0	0.2191	672.5	0.1465	672.5	0.1869	672.5	1.1553
914.5	0.2192	673.9	0.1466	673.9	0.1870	673.9	1.1554
916.0	0.2193	675.4	0.1467	675.4	0.1871	675.4	1.1555
917.5	0.2193	676.9	0.1467	676.9	0.1872	676.9	1.1556
919.0	0.2194	678.4	0.1468	678.4	0.1873	678.4	1.1558
920.5	0.2195	679.9	0.1469	679.9	0.1873	679.9	1.1559
922.0	0.2196	681.4	0.1470	681.4	0.1874	681.4	1.1560
923.5	0.2197	682.8	0.1471	682.8	0.1875	682.8	1.1561
925.0	0.2197	684.3	0.1471	684.3	0.1876	684.3	1.1562
926.5	0.2198	685.8	0.1472	685.8	0.1877	685.8	1.1564
928.0	0.2199	687.3	0.1473	687.3	0.1878	687.3	1.1565
929.5	0.2200	688.9	0.1474	688.9	0.1879	688.9	1.1566
931.0	0.2201	690.4	0.1474	690.4	0.1880	690.4	1.1567
932.5	0.2201	691.9	0.1475	691.9	0.1881	691.9	1.1569
934.0	0.2202	693.4	0.1476	693.4	0.1881	693.4	1.1570
935.5	0.2203	694.9	0.1477	694.9	0.1882	694.9	1.1571
937.0	0.2204	696.4	0.1478	696.4	0.1883	696.4	1.1572
938.5	0.2205	698.0	0.1478	698.0	0.1884	698.0	1.1574
940.0	0.2205	699.5	0.1479	699.5	0.1885	699.5	1.1575
941.5	0.2206	701.0	0.1480	701.0	0.1886	701.0	1.1576
943.0	0.2207	702.6	0.1481	702.6	0.1887	702.6	1.1577
944.5	0.2208	704.1	0.1481	704.1	0.1888	704.1	1.1579
946.0	0.2209	705.7	0.1482	705.7	0.1889	705.7	1.1580
947.5	0.2209	707.2	0.1483	707.2	0.1890	707.2	1.1581
949.0	0.2210	708.8	0.1484	708.8	0.1890	708.8	1.1583
950.5	0.2211	710.3	0.1485	710.3	0.1891	710.3	1.1584
952.0	0.2212	711.9	0.1485	711.9	0.1892	711.9	1.1585
953.5	0.2212	713.4	0.1486	713.4	0.1893	713.4	1.1587
955.0	0.2213	715.0	0.1487	715.0	0.1894	715.0	1.1588
956.5	0.2214	716.4	0.1488	716.4	0.1895	716.4	1.1587
958.0	0.2215	717.9	0.1489	717.9	0.1896	717.9	1.1587
959.5	0.2216	719.3	0.1489	719.3	0.1897	719.3	1.1587
961.0	0.2216	720.8	0.1490	720.8	0.1898	720.8	1.1587
962.5	0.2217	722.2	0.1491	722.2	0.1898	722.2	1.1588
964.0	0.2218	723.7	0.1491	723.7	0.1899	723.7	1.1588
965.5	0.2219	725.2	0.1492	725.2	0.1900	725.2	1.1589
967.0	0.2219	726.6	0.1493	726.6	0.1901	726.6	1.1590

Appendix F

Output Data: Aqtesolv Curve Match Data							
Elapsed Time (min)	TCM-2 Drawdown (ft)	Elapsed Time (min)	TCM-1 Drawdown (ft)	Elapsed Time (min)	TNX-11D Drawdown (ft)	Elapsed Time (min)	TGSC-1Z Drawdown (ft)
968.5	0.2220	728.1	0.1494	728.1	0.1902	728.1	1.1591
970.0	0.2221	729.6	0.1494	729.6	0.1903	729.6	1.1592
971.5	0.2222	731.0	0.1495	731.0	0.1903	731.0	1.1593
973.0	0.2223	732.5	0.1496	732.5	0.1904	732.5	1.1593
974.5	0.2223	734.0	0.1497	734.0	0.1905	734.0	1.1594
976.0	0.2224	735.5	0.1497	735.5	0.1906	735.5	1.1595
977.5	0.2225	736.9	0.1498	736.9	0.1907	736.9	1.1596
979.0	0.2226	738.4	0.1499	738.4	0.1908	738.4	1.1598
980.5	0.2226	739.9	0.1499	739.9	0.1908	739.9	1.1599
982.0	0.2227	741.4	0.1500	741.4	0.1909	741.4	1.1600
983.5	0.2228	742.9	0.1501	742.9	0.1910	742.9	1.1601
985.0	0.2229	744.4	0.1502	744.4	0.1911	744.4	1.1602
986.5	0.2229	745.9	0.1502	745.9	0.1912	745.9	1.1603
988.0	0.2230	747.4	0.1503	747.4	0.1913	747.4	1.1604
989.5	0.2231	748.9	0.1504	748.9	0.1914	748.9	1.1605
991.0	0.2232	750.4	0.1504	750.4	0.1914	750.4	1.1606
992.5	0.2232	751.9	0.1505	751.9	0.1915	751.9	1.1607
994.0	0.2233	753.4	0.1506	753.4	0.1916	753.4	1.1609
995.5	0.2234	755.0	0.1507	755.0	0.1917	755.0	1.1610
997.0	0.2235	756.5	0.1507	756.5	0.1918	756.5	1.1611
998.5	0.2236	758.0	0.1508	758.0	0.1919	758.0	1.1612
1000.0	0.2236	759.5	0.1509	759.5	0.1920	759.5	1.1613
1001.5	0.2237	761.1	0.1510	761.1	0.1920	761.1	1.1614
1003.0	0.2238	762.6	0.1510	762.6	0.1921	762.6	1.1616
1004.5	0.2239	764.1	0.1511	764.1	0.1922	764.1	1.1617
1006.0	0.2239	765.7	0.1512	765.7	0.1923	765.7	1.1618
1007.5	0.2240	767.2	0.1513	767.2	0.1924	767.2	1.1619
1009.0	0.2241	768.8	0.1513	768.8	0.1925	768.8	1.1620
1010.5	0.2242	770.3	0.1514	770.3	0.1926	770.3	1.1621
1012.0	0.2242	771.9	0.1515	771.9	0.1926	771.9	1.1623
1013.5	0.2243	773.4	0.1515	773.4	0.1927	773.4	1.1624
1015.0	0.2244	775.0	0.1516	775.0	0.1928	775.0	1.1625
1016.5	0.2245	776.4	0.1517	776.4	0.1929	776.4	1.1624
1018.0	0.2245	777.9	0.1518	777.9	0.1930	777.9	1.1624
1019.5	0.2246	779.3	0.1518	779.3	0.1931	779.3	1.1624
1021.0	0.2247	780.8	0.1519	780.8	0.1931	780.8	1.1624
1022.5	0.2248	782.3	0.1520	782.3	0.1932	782.3	1.1624
1024.0	0.2248	783.7	0.1520	783.7	0.1933	783.7	1.1625
1025.5	0.2249	785.2	0.1521	785.2	0.1934	785.2	1.1626
1027.0	0.2250	786.6	0.1522	786.6	0.1935	786.6	1.1626
1028.5	0.2251	788.1	0.1522	788.1	0.1936	788.1	1.1627
1030.0	0.2251	789.6	0.1523	789.6	0.1936	789.6	1.1628
1031.5	0.2252	791.1	0.1524	791.1	0.1937	791.1	1.1629
1033.0	0.2253	792.5	0.1524	792.5	0.1938	792.5	1.1630
1034.5	0.2254	794.0	0.1525	794.0	0.1939	794.0	1.1630
1036.0	0.2254	795.5	0.1526	795.5	0.1940	795.5	1.1631

Appendix F

Output Data: Aqtesolv Curve Match Data							
Elapsed Time (min)	TCM-2 Drawdown (ft)	Elapsed Time (min)	TCM-1 Drawdown (ft)	Elapsed Time (min)	TNX-11D Drawdown (ft)	Elapsed Time (min)	TGSC-1Z Drawdown (ft)
1037.5	0.2255	797.0	0.1527	797.0	0.1940	797.0	1.1632
1039.0	0.2256	798.5	0.1527	798.5	0.1941	798.5	1.1633
1040.5	0.2257	800.0	0.1528	800.0	0.1942	800.0	1.1634
1042.0	0.2257	801.4	0.1529	801.4	0.1943	801.4	1.1635
1043.5	0.2258	802.9	0.1529	802.9	0.1944	802.9	1.1636
1045.0	0.2259	804.4	0.1530	804.4	0.1944	804.4	1.1637
1046.5	0.2260	805.9	0.1531	805.9	0.1945	805.9	1.1638
1048.0	0.2260	807.4	0.1531	807.4	0.1946	807.4	1.1639
1049.5	0.2261	809.0	0.1532	809.0	0.1947	809.0	1.1640
1051.0	0.2262	810.5	0.1533	810.5	0.1948	810.5	1.1641
1052.5	0.2262	812.0	0.1533	812.0	0.1948	812.0	1.1642
1054.0	0.2263	813.5	0.1534	813.5	0.1949	813.5	1.1643
1055.5	0.2264	815.0	0.1535	815.0	0.1950	815.0	1.1644
1057.0	0.2265	816.5	0.1535	816.5	0.1951	816.5	1.1645
1058.5	0.2265	818.1	0.1536	818.1	0.1952	818.1	1.1647
1060.0	0.2266	819.6	0.1537	819.6	0.1952	819.6	1.1648
1061.5	0.2267	821.1	0.1537	821.1	0.1953	821.1	1.1649
1063.0	0.2268	822.6	0.1538	822.6	0.1954	822.6	1.1650
1064.5	0.2268	824.2	0.1539	824.2	0.1955	824.2	1.1651
1066.0	0.2269	825.7	0.1540	825.7	0.1956	825.7	1.1652
1067.5	0.2270	827.3	0.1540	827.3	0.1957	827.3	1.1653
1069.0	0.2271	828.8	0.1541	828.8	0.1957	828.8	1.1654
1070.5	0.2271	830.3	0.1542	830.3	0.1958	830.3	1.1655
1072.0	0.2272	831.9	0.1542	831.9	0.1959	831.9	1.1656
1073.5	0.2273	833.4	0.1543	833.4	0.1960	833.4	1.1657
1075.0	0.2273	835.0	0.1544	835.0	0.1961	835.0	1.1659
1076.5	0.2274	836.5	0.1544	836.5	0.1962	836.5	1.1658
1078.0	0.2275	837.9	0.1545	837.9	0.1962	837.9	1.1657
1079.5	0.2276	839.4	0.1546	839.4	0.1963	839.4	1.1657
1081.0	0.2276	840.8	0.1546	840.8	0.1964	840.8	1.1657
1082.5	0.2277	842.3	0.1547	842.3	0.1965	842.3	1.1657
1084.0	0.2278	843.7	0.1548	843.7	0.1966	843.7	1.1658
1085.5	0.2279	845.2	0.1548	845.2	0.1966	845.2	1.1659
1087.0	0.2279	846.7	0.1549	846.7	0.1967	846.7	1.1659
1088.5	0.2280	848.1	0.1550	848.1	0.1968	848.1	1.1660
1090.0	0.2281	849.6	0.1550	849.6	0.1969	849.6	1.1661
1360.5	0.2409	851.1	0.1551	851.1	0.1969	851.1	1.1661
1698.0	0.2555	852.6	0.1551	852.6	0.1970	852.6	1.1662
2119.3	0.2715	854.0	0.1552	854.0	0.1971	854.0	1.1663
2645.2	0.2887	855.5	0.1553	855.5	0.1972	855.5	1.1664
3301.5	0.3070	857.0	0.1553	857.0	0.1973	857.0	1.1665
4120.7	0.3260	858.5	0.1554	858.5	0.1973	858.5	1.1666
5143.1	0.3453	860.0	0.1555	860.0	0.1974	860.0	1.1666
6419.3	0.3648	861.5	0.1555	861.5	0.1975	861.5	1.1667
8012.0	0.3840	863.0	0.1556	863.0	0.1976	863.0	1.1668
10000.0	0.4028	864.5	0.1557	864.5	0.1976	864.5	1.1669

Appendix F

Output Data: Aqtesolv Curve Match Data							
Elapsed Time (min)	TCM-2 Drawdown (ft)	Elapsed Time (min)	TCM-1 Drawdown (ft)	Elapsed Time (min)	TNX-11D Drawdown (ft)	Elapsed Time (min)	TGSC-1Z Drawdown (ft)
		866.0	0.1557	866.0	0.1977	866.0	1.1670
		867.5	0.1558	867.5	0.1978	867.5	1.1671
		869.0	0.1559	869.0	0.1979	869.0	1.1672
		870.5	0.1559	870.5	0.1980	870.5	1.1673
		872.0	0.1560	872.0	0.1980	872.0	1.1674
		873.5	0.1560	873.5	0.1981	873.5	1.1675
		875.0	0.1561	875.0	0.1982	875.0	1.1676
		876.6	0.1562	876.6	0.1983	876.6	1.1677
		878.1	0.1562	878.1	0.1983	878.1	1.1678
		879.6	0.1563	879.6	0.1984	879.6	1.1679
		881.1	0.1564	881.1	0.1985	881.1	1.1680
		882.7	0.1564	882.7	0.1986	882.7	1.1681
		884.2	0.1565	884.2	0.1987	884.2	1.1682
		885.7	0.1566	885.7	0.1987	885.7	1.1683
		887.3	0.1566	887.3	0.1988	887.3	1.1684
		888.8	0.1567	888.8	0.1989	888.8	1.1685
		890.4	0.1568	890.4	0.1990	890.4	1.1686
		891.9	0.1568	891.9	0.1991	891.9	1.1687
		893.4	0.1569	893.4	0.1992	893.4	1.1688
		895.0	0.1570	895.0	0.1992	895.0	1.1689
		896.5	0.1570	896.5	0.1993	896.5	1.1688
		897.9	0.1571	897.9	0.1994	897.9	1.1687
		899.4	0.1572	899.4	0.1995	899.4	1.1687
		900.8	0.1572	900.8	0.1995	900.8	1.1687
		902.3	0.1573	902.3	0.1996	902.3	1.1688
		903.8	0.1573	903.8	0.1997	903.8	1.1688
		905.2	0.1574	905.2	0.1998	905.2	1.1689
		906.7	0.1575	906.7	0.1998	906.7	1.1689
		908.2	0.1575	908.2	0.1999	908.2	1.1690
		909.6	0.1576	909.6	0.2000	909.6	1.1691
		911.1	0.1576	911.1	0.2001	911.1	1.1691
		912.6	0.1577	912.6	0.2001	912.6	1.1692
		914.1	0.1578	914.1	0.2002	914.1	1.1693
		915.6	0.1578	915.6	0.2003	915.6	1.1694
		917.0	0.1579	917.0	0.2004	917.0	1.1694
		918.5	0.1579	918.5	0.2004	918.5	1.1695
		920.0	0.1580	920.0	0.2005	920.0	1.1696
		921.5	0.1581	921.5	0.2006	921.5	1.1697
		923.0	0.1581	923.0	0.2007	923.0	1.1698
		924.5	0.1582	924.5	0.2007	924.5	1.1699
		926.0	0.1583	926.0	0.2008	926.0	1.1699
		927.5	0.1583	927.5	0.2009	927.5	1.1700
		929.0	0.1584	929.0	0.2010	929.0	1.1701
		930.5	0.1584	930.5	0.2010	930.5	1.1702
		932.0	0.1585	932.0	0.2011	932.0	1.1703
		933.6	0.1586	933.6	0.2012	933.6	1.1704

Appendix F

Output Data: Aqtesolv Curve Match Data							
Elapsed Time (min)	TCM-2 Drawdown (ft)	Elapsed Time (min)	TCM-1 Drawdown (ft)	Elapsed Time (min)	TNX-11D Drawdown (ft)	Elapsed Time (min)	TGSC-1Z Drawdown (ft)
		935.1	0.1586	935.1	0.2013	935.1	1.1705
		936.6	0.1587	936.6	0.2013	936.6	1.1706
		938.1	0.1587	938.1	0.2014	938.1	1.1707
		939.6	0.1588	939.6	0.2015	939.6	1.1708
		941.2	0.1589	941.2	0.2016	941.2	1.1709
		942.7	0.1589	942.7	0.2017	942.7	1.1710
		944.2	0.1590	944.2	0.2017	944.2	1.1710
		945.8	0.1591	945.8	0.2018	945.8	1.1711
		947.3	0.1591	947.3	0.2019	947.3	1.1712
		948.8	0.1592	948.8	0.2020	948.8	1.1713
		950.4	0.1592	950.4	0.2020	950.4	1.1714
		951.9	0.1593	951.9	0.2021	951.9	1.1715
		953.5	0.1594	953.5	0.2022	953.5	1.1716
		955.0	0.1594	955.0	0.2023	955.0	1.1717
		956.5	0.1595	956.5	0.2024	956.5	1.1716
		957.9	0.1596	957.9	0.2024	957.9	1.1715
		959.4	0.1596	959.4	0.2025	959.4	1.1715
		960.8	0.1597	960.8	0.2026	960.8	1.1715
		962.3	0.1597	962.3	0.2027	962.3	1.1716
		963.8	0.1598	963.8	0.2027	963.8	1.1716
		965.2	0.1598	965.2	0.2028	965.2	1.1716
		966.7	0.1599	966.7	0.2029	966.7	1.1717
		968.2	0.1600	968.2	0.2030	968.2	1.1718
		969.7	0.1600	969.7	0.2030	969.7	1.1718
		971.1	0.1601	971.1	0.2031	971.1	1.1719
		972.6	0.1601	972.6	0.2032	972.6	1.1720
		974.1	0.1602	974.1	0.2032	974.1	1.1720
		975.6	0.1603	975.6	0.2033	975.6	1.1721
		977.1	0.1603	977.1	0.2034	977.1	1.1722
		978.6	0.1604	978.6	0.2035	978.6	1.1722
		980.1	0.1604	980.1	0.2035	980.1	1.1723
		981.5	0.1605	981.5	0.2036	981.5	1.1724
		983.0	0.1606	983.0	0.2037	983.0	1.1725
		984.5	0.1606	984.5	0.2038	984.5	1.1726
		986.0	0.1607	986.0	0.2038	986.0	1.1726
		987.5	0.1607	987.5	0.2039	987.5	1.1727
		989.1	0.1608	989.1	0.2040	989.1	1.1728
		990.6	0.1608	990.6	0.2040	990.6	1.1729
		992.1	0.1609	992.1	0.2041	992.1	1.1730
		993.6	0.1610	993.6	0.2042	993.6	1.1731
		995.1	0.1610	995.1	0.2043	995.1	1.1732
		996.6	0.1611	996.6	0.2043	996.6	1.1732
		998.1	0.1611	998.1	0.2044	998.1	1.1733
		999.7	0.1612	999.7	0.2045	999.7	1.1734
		1001.2	0.1613	1001.2	0.2046	1001.2	1.1735
		1002.7	0.1613	1002.7	0.2046	1002.7	1.1736

Appendix F

Output Data: Aqtesolv Curve Match Data							
Elapsed Time (min)	TCM-2 Drawdown (ft)	Elapsed Time (min)	TCM-1 Drawdown (ft)	Elapsed Time (min)	TNX-11D Drawdown (ft)	Elapsed Time (min)	TGSC-1Z Drawdown (ft)
		1004.2	0.1614	1004.2	0.2047	1004.2	1.1737
		1005.8	0.1614	1005.8	0.2048	1005.8	1.1738
		1007.3	0.1615	1007.3	0.2049	1007.3	1.1739
		1008.8	0.1616	1008.8	0.2049	1008.8	1.1740
		1010.4	0.1616	1010.4	0.2050	1010.4	1.1741
		1011.9	0.1617	1011.9	0.2051	1011.9	1.1742
		1013.5	0.1617	1013.5	0.2052	1013.5	1.1742
		1015.0	0.1618	1015.0	0.2053	1015.0	1.1743
		1016.5	0.1619	1016.5	0.2053	1016.5	1.1742
		1017.9	0.1619	1017.9	0.2054	1017.9	1.1741
		1019.4	0.1620	1019.4	0.2055	1019.4	1.1741
		1020.9	0.1620	1020.9	0.2055	1020.9	1.1741
		1022.3	0.1621	1022.3	0.2056	1022.3	1.1742
		1023.8	0.1621	1023.8	0.2057	1023.8	1.1742
		1025.3	0.1622	1025.3	0.2058	1025.3	1.1742
		1026.7	0.1623	1026.7	0.2058	1026.7	1.1743
		1028.2	0.1623	1028.2	0.2059	1028.2	1.1743
		1029.7	0.1624	1029.7	0.2060	1029.7	1.1744
		1031.2	0.1624	1031.2	0.2060	1031.2	1.1744
		1032.6	0.1625	1032.6	0.2061	1032.6	1.1745
		1034.1	0.1625	1034.1	0.2062	1034.1	1.1746
		1035.6	0.1626	1035.6	0.2063	1035.6	1.1746
		1037.1	0.1626	1037.1	0.2063	1037.1	1.1747
		1038.6	0.1627	1038.6	0.2064	1038.6	1.1748
		1040.1	0.1628	1040.1	0.2065	1040.1	1.1749
		1041.6	0.1628	1041.6	0.2065	1041.6	1.1749
		1043.1	0.1629	1043.1	0.2066	1043.1	1.1750
		1044.6	0.1629	1044.6	0.2067	1044.6	1.1751
		1046.1	0.1630	1046.1	0.2068	1046.1	1.1752
		1047.6	0.1630	1047.6	0.2068	1047.6	1.1752
		1049.1	0.1631	1049.1	0.2069	1049.1	1.1753
		1050.6	0.1631	1050.6	0.2070	1050.6	1.1754
		1052.1	0.1632	1052.1	0.2070	1052.1	1.1755
		1053.6	0.1633	1053.6	0.2071	1053.6	1.1756
		1055.1	0.1633	1055.1	0.2072	1055.1	1.1757
		1056.6	0.1634	1056.6	0.2073	1056.6	1.1757
		1058.2	0.1634	1058.2	0.2073	1058.2	1.1758
		1059.7	0.1635	1059.7	0.2074	1059.7	1.1759
		1061.2	0.1635	1061.2	0.2075	1061.2	1.1760
		1062.7	0.1636	1062.7	0.2076	1062.7	1.1761
		1064.3	0.1637	1064.3	0.2076	1064.3	1.1762
		1065.8	0.1637	1065.8	0.2077	1065.8	1.1763
		1067.3	0.1638	1067.3	0.2078	1067.3	1.1763
		1068.8	0.1638	1068.8	0.2078	1068.8	1.1764
		1070.4	0.1639	1070.4	0.2079	1070.4	1.1765
		1071.9	0.1639	1071.9	0.2080	1071.9	1.1766

Appendix F

Output Data: Aqtesolv Curve Match Data							
Elapsed Time (min)	TCM-2 Drawdown (ft)	Elapsed Time (min)	TCM-1 Drawdown (ft)	Elapsed Time (min)	TNX-11D Drawdown (ft)	Elapsed Time (min)	TGSC-1Z Drawdown (ft)
		1073.5	0.1640	1073.5	0.2081	1073.5	1.1767
		1075.0	0.1641	1075.0	0.2081	1075.0	1.1768
		1075.4	0.1641	1075.4	0.2082	1075.4	1.1768
		1075.8	0.1641	1075.8	0.2082	1075.8	1.1767
		1076.1	0.1641	1076.1	0.2082	1076.1	1.1767
		1076.5	0.1641	1076.5	0.2082	1076.5	1.1767
		1076.9	0.1641	1076.9	0.2082	1076.9	1.1766
		1077.2	0.1641	1077.2	0.2083	1077.2	1.1766
		1077.6	0.1642	1077.6	0.2083	1077.6	1.1766
		1078.0	0.1642	1078.0	0.2083	1078.0	1.1766
		1078.4	0.1642	1078.4	0.2083	1078.4	1.1766
		1078.7	0.1642	1078.7	0.2083	1078.7	1.1766
		1079.1	0.1642	1079.1	0.2083	1079.1	1.1766
		1079.5	0.1642	1079.5	0.2084	1079.5	1.1765
		1079.9	0.1642	1079.9	0.2084	1079.9	1.1765
		1080.2	0.1643	1080.2	0.2084	1080.2	1.1765
		1080.6	0.1643	1080.6	0.2084	1080.6	1.1765
		1081.0	0.1643	1081.0	0.2084	1081.0	1.1766
		1081.4	0.1643	1081.4	0.2085	1081.4	1.1766
		1081.7	0.1643	1081.7	0.2085	1081.7	1.1766
		1082.1	0.1643	1082.1	0.2085	1082.1	1.1766
		1082.5	0.1643	1082.5	0.2085	1082.5	1.1766
		1082.9	0.1644	1082.9	0.2085	1082.9	1.1766
		1083.2	0.1644	1083.2	0.2085	1083.2	1.1766
		1083.6	0.1644	1083.6	0.2086	1083.6	1.1766
		1084.0	0.1644	1084.0	0.2086	1084.0	1.1766
		1084.4	0.1644	1084.4	0.2086	1084.4	1.1766
		1084.7	0.1644	1084.7	0.2086	1084.7	1.1766
		1085.1	0.1644	1085.1	0.2086	1085.1	1.1766
		1085.5	0.1645	1085.5	0.2087	1085.5	1.1766
		1085.9	0.1645	1085.9	0.2087	1085.9	1.1767
		1086.2	0.1645	1086.2	0.2087	1086.2	1.1767
		1086.6	0.1645	1086.6	0.2087	1086.6	1.1767
		1087.0	0.1645	1087.0	0.2087	1087.0	1.1767
		1087.4	0.1645	1087.4	0.2087	1087.4	1.1767
		1087.7	0.1645	1087.7	0.2088	1087.7	1.1767
		1088.1	0.1645	1088.1	0.2088	1088.1	1.1767
		1088.5	0.1646	1088.5	0.2088	1088.5	1.1767
		1088.9	0.1646	1088.9	0.2088	1088.9	1.1768
		1089.3	0.1646	1089.3	0.2088	1089.3	1.1768
		1089.6	0.1646	1089.6	0.2089	1089.6	1.1768
		1090.0	0.1646	1090.0	0.2089	1090.0	1.1768
		1152.1	0.1668	1152.1	0.2118	1152.1	1.1797
		1217.7	0.1692	1217.7	0.2149	1217.7	1.1834
		1287.1	0.1717	1287.1	0.2183	1287.1	1.1874
		1360.5	0.1742	1360.5	0.2218	1360.5	1.1915

Appendix F

Output Data: Aqtesolv Curve Match Data							
Elapsed Time (min)	TCM-2 Drawdown (ft)	Elapsed Time (min)	TCM-1 Drawdown (ft)	Elapsed Time (min)	TNX-11D Drawdown (ft)	Elapsed Time (min)	TGSC-1Z Drawdown (ft)
		1438.0	0.1768	1438.0	0.2254	1438.0	1.1957
		1519.9	0.1795	1519.9	0.2292	1519.9	1.2001
		1606.5	0.1823	1606.5	0.2333	1606.5	1.2046
		1698.0	0.1852	1698.0	0.2374	1698.0	1.2093
		1794.8	0.1881	1794.8	0.2418	1794.8	1.2141
		1897.0	0.1912	1897.0	0.2464	1897.0	1.2190
		2005.1	0.1943	2005.1	0.2512	2005.1	1.2241
		2119.3	0.1975	2119.3	0.2562	2119.3	1.2294
		2240.1	0.2009	2240.1	0.2615	2240.1	1.2348
		2367.7	0.2043	2367.7	0.2670	2367.7	1.2404
		2502.6	0.2078	2502.6	0.2727	2502.6	1.2461
		2645.2	0.2114	2645.2	0.2788	2645.2	1.2520
		2795.9	0.2151	2795.9	0.2851	2795.9	1.2581
		2955.2	0.2189	2955.2	0.2916	2955.2	1.2643
		3123.6	0.2228	3123.6	0.2985	3123.6	1.2706
		3301.5	0.2268	3301.5	0.3057	3301.5	1.2772
		3489.6	0.2309	3489.6	0.3132	3489.6	1.2839
		3688.4	0.2351	3688.4	0.3209	3688.4	1.2908
		3898.6	0.2394	3898.6	0.3290	3898.6	1.2978
		4120.7	0.2437	4120.7	0.3375	4120.7	1.3050
		4355.5	0.2482	4355.5	0.3462	4355.5	1.3123
		4603.6	0.2528	4603.6	0.3553	4603.6	1.3198
		4865.9	0.2574	4865.9	0.3647	4865.9	1.3274
		5143.1	0.2621	5143.1	0.3744	5143.1	1.3351
		5436.2	0.2669	5436.2	0.3844	5436.2	1.3430
		5745.9	0.2718	5745.9	0.3948	5745.9	1.3510
		6073.3	0.2768	6073.3	0.4055	6073.3	1.3591
		6419.3	0.2818	6419.3	0.4165	6419.3	1.3673
		6785.0	0.2868	6785.0	0.4277	6785.0	1.3756
		7171.6	0.2920	7171.6	0.4393	7171.6	1.3840
		7580.2	0.2972	7580.2	0.4511	7580.2	1.3925
		8012.0	0.3024	8012.0	0.4632	8012.0	1.4011
		8468.5	0.3077	8468.5	0.4756	8468.5	1.4097
		8951.0	0.3130	8951.0	0.4881	8951.0	1.4183
		9461.0	0.3184	9461.0	0.5009	9461.0	1.4270
		10000.0	0.3238	10000.0	0.5139	10000.0	1.4357