



Lawrence Berkeley Laboratory

UNIVERSITY OF CALIFORNIA

Engineering Division

Presented at the 2nd Symposium on Space Cryogenics,
Frascati, Italy, July 18-19, 1988, and
to be published in Cryogenics

Cryogenic Techniques for Large Superconducting Magnets in Space

M.A. Green

December 1988

Received by OSTI
JUN 07 1989

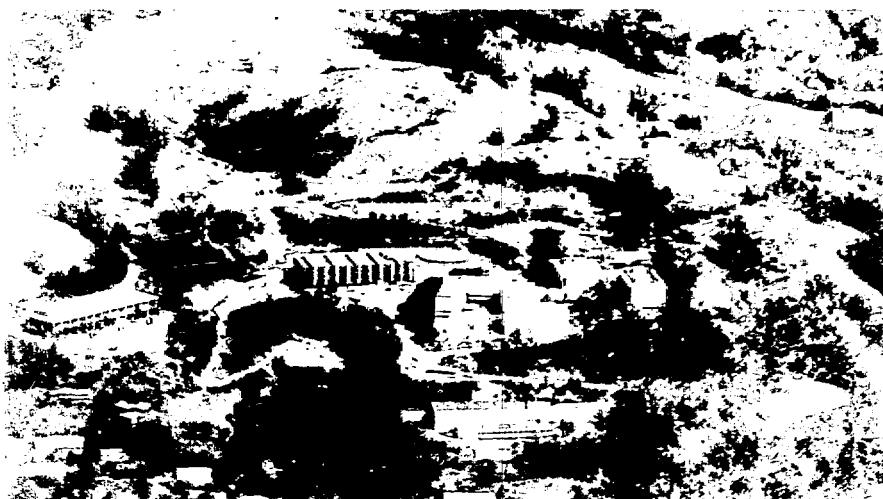

LEGAL NOTICE

This report was prepared as an account of work sponsored by the United States Government. Neither the United States nor the National Aeronautics and Space Administration, nor the United States Department of Energy, nor any of their employees, nor any of their contractors, subcontractors, or their employees, makes any warranty, express or implied, or assumes any legal liability or responsibility for the accuracy, completeness or usefulness of any information, apparatus, product or process disclosed, or represents that its use would not infringe privately owned rights.

DISCLAIMER

This document was prepared as an account of work sponsored by the United States Government. Neither the United States Government nor any agency thereof, nor The Regents of the University of California nor any of their employees, makes any warranty, express or implied, or assumes any legal liability or responsibility for the accuracy, completeness, or usefulness of any information, apparatus, product, or process disclosed, or represents that its use would not infringe privately owned rights. Reference herein to any specific commercial products, process, or service by its trade name, trademark, manufacturer, or otherwise, does not necessarily constitute or imply its endorsement, recommendation, or favoring by the United States Government or any agency thereof, or The Regents of the University of California. The views and opinions of authors expressed herein do not necessarily state or reflect those of the United States Government or any agency thereof, or The Regents of the University of California and shall not be used for advertising or product endorsement purposes.

Lawrence Berkeley Laboratory is an equal opportunity employer.

LBL--25735

DE89 013431

Cryogenic Techniques for Large Superconducting Magnets in Space

Michael A. Green

**Engineering Division
Lawrence Berkeley Laboratory
1 Cyclotron Road
Berkeley, California 94720**

December 1988

UNIVERSITY MICROFILMS
SERIALS ACQUISITION
300 N ZEEB RD
ANN ARBOR MI 48106

Michael A. Green

Lawrence Berkeley Laboratory
1 Cyclotron Road, Mail Stop 90-2148
Berkeley, CA 94720
USA

A large superconducting magnet is proposed for use in a particle astrophysics experiment, ASTROMAG, which is to be mounted on the United States Space Station. This experiment will have a two-coil superconducting magnet with coils which are 1.3 to 1.7 meters in diameter. The two-coil magnet will have zero net magnetic dipole moment. The field 15 meters from the magnet will approach earth's field in low earth orbit. The issue of high Tc superconductor will be discussed in the paper. The reasons for using conventional niobium-titanium superconductor cooled with superfluid helium will be presented.

Since the purpose of the magnet is to do particle astrophysics, the superconducting coils must be located close to the charged particle detectors. The trade off between the particle physics possible and the cryogenic insulation around the coils is discussed. As a result, the ASTROMAG magnet coils will be operated outside of the superfluid helium storage tank. The fountain effect pumping system which will be used to cool the coil is described in the report. Two methods for extending the operating life of the superfluid helium dewar are discussed. These include: 1) operation with a third shield cooled to 90 K with a sterling cycle cryocooler, and 2) a hybrid cryogenic system where there are three hydrogen-cooled shields and cryostat support heat intercept points. Both of these methods will extend the ASTROMAG cryogenic operating life from 2 years to almost 4 years.

BACKGROUND

Particle astrophysics benefits greatly from observations above the earth's atmosphere. Particle astrophysics in space will help answer the questions which have resulted from recent unexpected experimental data. Experiments which look at anti-matter in cosmic rays and experiments which investigate the isotopic composition of particles from deep space will benefit greatly from a magnet in space. Over the past three years, a particle astrophysics team has examined how a large magnetic spectrometer outside the earth's atmosphere for an extended period of time can be used to answer some of the questions which physicists are now asking.¹

A facility which consists of a superconducting magnet and two different physics detectors will form the core of an experiment proposed for the Space Station.² This paper will describe the superconducting magnet and its cryogenic system.

Three types of cryogenic systems have been investigated for superconducting magnet cooling in space using the proposed ASTROMAG coils as a basis for comparison.

The heart of a charged particle detection system for ASTROMAG is the superconducting magnet. The scientific capabilities of the facility depend in important ways on the size, shape and placement of the magnet coils. The coil configuration strongly influences the cost and complexity of the facility.

The following constraints have been put on target magnet configurations for ASTROMAG:

- 1) The magnet cryostat and the experimental detectors can have a maximum diameter of about 3 meters. The length of the magnet and detectors should be less than 6 meters.
- 2) The overall mass of the magnet coils, the tankage, the coolant and the cryostat should be less than 2000 kg.
- 3) The net magnetic dipole moment must be zero so that the earth's magnetic field produces no significant torques on the Space Station, and the field should fall to the earth's magnetic field at a distance of less than 15 meters from the magnet center.
- 4) The coil should utilize a tested reliable superconductor with a peak field of less than 8.0 T.
- 5) The magnet will operate in the persistent mode. The magnet will have to be designed so that it can quench in a fail-safe way if a normal region forms in either the magnet coil or the persistent switch. The magnet should be designed so that it can be charged and discharged at least four times per year.
- 6) The cryogenic insulation system should maintain the magnet at its design operating temperature for a period of 18 months to three years between cryogen refills. The magnet will be launched cold.
- 7) The magnet and its cryostat shall operate in a shuttle environment, which means the magnet and its support hardware shall withstand both launch and landing conditions for the shuttle. This means that the magnet shall be designed to withstand accelerations of 10 to 12 g's in any direction. The mechanical resonant frequency for key components shall be greater than 35 Hz. The external temperature of the vacuum vessel should have a design value between 250 and 310 K. The external design pressure is 1.0 atm.

This report examines the choice of superconductor for the magnet for ASTROMAG. The choice of superconductor is in part dictated by the choice of the cryogen used to cool the magnet. The magnet coil and cryostat configuration are presented for the HEAO type magnet, which is the strawman configuration for the proposed ASTROMAG experiment.

SELECTION OF SUPERCONDUCTOR

Two years ago there would have been no question about selection of superconductor for superconducting magnets in space. At that time the conductor of choice would have been niobium-titanium. The discovery

of the new high critical temperature (high T_c) superconductors³ requires one to reevaluate this decision. The pressure for this reevaluation becomes stronger with the discovery of the yttrium-barium class of superconductors which have a zero resistance critical temperature of about 93 K.⁴ These conductors could theoretically be used with liquid nitrogen as a coolant.

Table 1 compares the properties of a modern niobium titanium superconductor with the yttrium barium copper oxide 1-2-3 conductor.^{5,6} The important things to note are: 1) The new conductor is a ceramic which is more brittle than niobium titanium alloy. 2) There is some uncertainty as to what upper critical field is. It is felt that this is caused by the granular nature of the superconductor. 3) There is the potential for high critical current density, but in bulk sintered samples this conductor cannot carry much transport current. Melted samples and thin film forms of the high T_c superconductors are capable of carrying much higher transport currents than the bulk sintered conductors. At this time, samples of yttrium barium copper oxide conductor or the newer bismuth or thallium five-component copper oxide superconductors have not been made in a form which is usable for superconducting magnets like the ASTROMAG magnet.

High T_c superconductor has been shown to be more stable than niobium titanium (the adiabatic and dynamic stability diameters are larger for the high T_c superconductor operating either liquid hydrogen or liquid nitrogen temperatures), and the energy per unit volume required to initiate a quench is a couple of orders of magnitude higher for the high T_c superconductors.^{7,8} The increased stability of the high T_c superconductor is a curse as well as a benefit, because the rate of normal region propagation is much slower (by five to seven orders of magnitude by volume) than for niobium titanium. Cryostability may be required for magnets which use high T_c superconductor.

In liquid hydrogen, a cryostable high T_c superconductor can operate at current densities as high as 250 A mm^{-2} in the superconductor plus matrix. (High T_c superconductor operated in helium or nitrogen will have a cryostable matrix current density of 50 to 70 A mm^{-2} .) A current density of 250 A mm^{-2} is only marginally high enough for space applications of superconductor for magnets. (High current density superconducting coils are required in order to insure that the coils have a low cold mass. The magnet cold mass is, in general, proportional to the stored magnetic energy in the magnet.²)

The last factor which affects whether or not an ideal high T_c superconductor is usable is the choice of working fluids. Table 2 compares the properties of liquid helium, hydrogen, neon and nitrogen.^{9,10} Helium has the lowest boiling point and two liquid phases. The superfluid phase can be phase separated from the gas by using a porous plug even in a weightless environment. Helium has a low heat of vaporization, but on the other hand it has a rather high specific heat at constant pressure. Nitrogen has a high heat of vaporization and a low specific heat. Hydrogen has a high heat of

Table 1. Properties of Nb-Ti and Y Ba₂ Cu₃ O_{7-x} Superconductors

| | Nb-Ti ^a T _{op} = 4.2 K | Y-Ba-Cu-O T _{op} = 77 K |
|--|---|-------------------------------------|
| Type of Material | Metal Alloy | Ceramic |
| Critical Temperature (K) | 9.4 | 93 |
| Density (kg m ⁻³) | 6700 | 6380 ^b |
| Specific Heat at T _{op} (J m ⁻³ K ⁻¹) | 5.76 x 10 ³ | 1.0 x 10 ⁶ |
| Thermal Conductivity at T _{op} (W m ⁻¹ K ⁻¹) | 0.275 | ~13 |
| Thermal Contraction Coefficient at 300 K | ~10 ⁻⁵ | 1.3 x 10 ⁻⁵ |
| Total Thermal Contraction Coefficient 300 K - T _{op} | ~2.0 x 10 ⁻³ | ~ 2.3 x 10 ⁻³ |
| Elastic Modulus at T _{op} (G Pa) | 83 | 90 - 110 |
| Ultimate Strength at T _{op} (M Pa) | ~2200 | Variable |
| Ductility | Ductile | Brittle |

^a For Nb-46.5 w% Ti.

^b Void-free sample, typical sintered samples are lower than this value.

Table 2. Properties of Four Liquid Gases That Can Be Used to Cool Superconductor

| | Helium | Hydrogen | Neon | Nitrogen |
|---|--------|-------------------|-------|----------|
| 1 atm Boiling Temperature (K) | 4.22 | 20.3 | 27.1 | 77.4 |
| Critical Temperature (K) | 5.19 | 33.3 | 44.5 | 126.1 |
| 1 atm Liquid Density (kg m ⁻³) | 125 | 70.8 | 1205 | 811 |
| 1 atm Heat of Vaporization (Jg ⁻¹) | 20.8 | 442 ^a | 86.8 | 198 |
| Gas Specific Heat (Jg ⁻¹ K ⁻¹) | 5.19 | 14.6 | 1.04 | 1.03 |
| Available Refrigeration Liquid to 300 K (Jg ⁻¹) | 1561 | 4629 ^b | 369 | 431 |
| Design Nucleate Boiling Heat Flux ^c (W m ⁻²) | 2500 | 30000 | 50000 | 60000 |
| Design Nucleate Boiling ΔT^c (K) | 0.5 | 1.7 | 2.4 | 6.8 |

^a para hydrogen

^b includes the para to ortho transition energy

^c about 30 percent of the maximum nucleate boiling heat flux

vaporization and a high specific heat. One gets the most refrigeration per unit mass out of hydrogen (4630 J g^{-1}). Helium is next best (1561 J g^{-1}) and nitrogen is much lower than helium (431 J g^{-1}). Liquid neon has the lowest available refrigeration which, like liquid nitrogen, makes it unsuitable for a superconducting magnet refrigerant. Hydrogen would be the best stored cryogen to use in space except that it is extremely flammable, and its use is not allowed on either the Space Station or the shuttle. (Hydrogen might be a suitable coolant on a free flyer.) If one is to cool the magnet on the Space Station with stored liquid cryogen, helium is the cryogen of choice. (One would use conventional niobium titanium superconductor with liquid helium.)

It can be concluded that high T_c superconductor is not attractive for superconducting magnets in space unless: 1) there is a significant improvement in the ability to carry current; 2) the superconductor must be combined with a metal matrix; 3) the brittleness problem must be solved; 4) the superconductor probably has to be used in the cryostable mode; and 5) the superconductor must be run in a liquid hydrogen bath. In short, the best superconductor to use for superconducting magnets in space will be niobium titanium cooled by liquid helium.. Helium II is preferable over helium I because liquid-gas phase separation can be achieved using a porous plug and helium II can be pumped without moving parts using the fountain effect.

ASTROMAG COIL CONFIGURATIONS

The strawman configuration for ASTROMAG is two solenoidal coils which are operated at opposite polarity so that the net magnetic dipole moment is zero. This configuration was studied in the early 1970's for the HEAO experiment.¹¹ The difference between the HEAO experiment and the strawman ASTROMAG configuration is the fact that the ASTROMAG superconducting coils are to be located outside of the helium tank. Placing the superconducting coils outside of the helium tank permits one to move the coil as close as possible to the physics detectors. In addition, coil outside the tank can be decoupled thermally from the helium tank during a magnet quench. Helium from the tank is pumped to the coils and the persistent switch using a superfluid thermomechanical (fountain effect) helium pump.¹² Other coil configurations have been studied (such as the two coil toroid),¹³ but the coils discussed in this paper will be limited to the HEAO type because this configuration results in the simplest (and probably the cheapest) cryostat and cryogenic configuration.

Table 3 compares two HEAO configurations with coil outside diameters of 1.3 meters and 1.7 meters. Both of these coil configurations have a design stored magnetic energy of 11 MJ and an overall coil system cold mass just over 600 kg. The coil configuration with 1.3 meter coil outside diameter and a spherical helium tank is illustrated in Figure 1. If one wants to use cylindrical helium tankage, the coil diameter has to be increased or the separation between coil must be increased (the helium storage tank length is also increased). The cylindrical helium storage tank with 1.7 meter outside diameter coils is illustrated in Figure 2. The cases shown in Figures 1 and 2 are the same two cases illustrated in Table 3.

**Table 3. Parameters of Two 11 MJ
ASTROMAG Superconducting Magnets**

| | Case 1 | Case 2 |
|---|-------------------------|-------------------------|
| Number of Coils | 2 | 2 |
| Number of Turns | 6120 | 4624 |
| Coil Outside Diameter | 1.30 | 1.70 |
| Coil Width (mm) | 230 | 174 |
| Coil Thickness (mm) | 50 | 50 |
| Space Between Coils (m) | 1.70 | 1.86 |
| Magnet Self Inductance (H) | 34.5 | 31.1 |
| 11 MJ Design Current (A) | 798.2 | 840.6 |
| Peak Induction in Coil (T)* | ~7.1 | ~6.8 |
| Matrix J (A mm ⁻²)* | 402 | 423 |
| E J ² Limit (J A ² m ⁻⁴)* | 1.78 x 10 ²⁴ | 1.97 x 10 ²⁴ |
| Intercoil Tensile Force (N)* | 2.53 x 10 ⁵ | 3.21 x 10 ⁵ |
| Energy per Active Coil Mass (J g ⁻¹)* | 18.8 | 18.8 |
| Coil T at End of Quench (K)* | 119 | 119 |

*At the 11 MJ stored energy design current.

Figure 1

ASTROMAG HEAO TYPE MAGNET with a Spherical Helium Storage Tank and 1.3 meter Diameter Coils

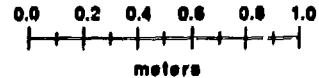
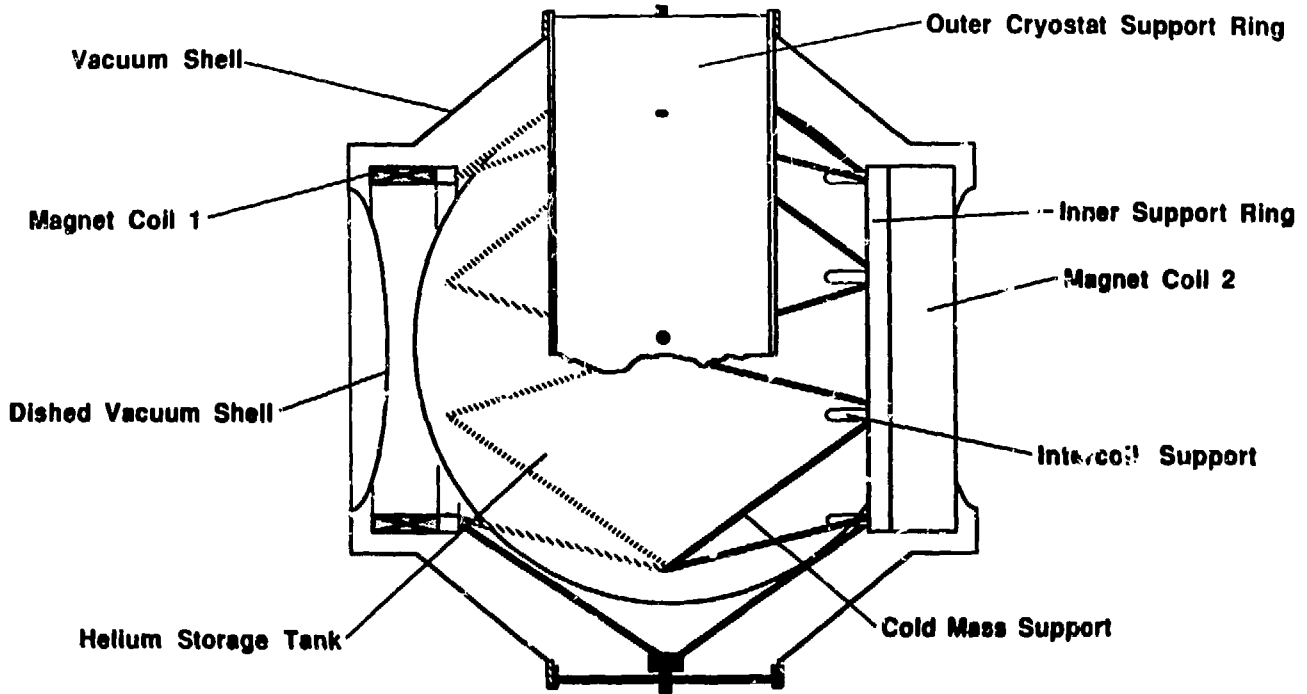
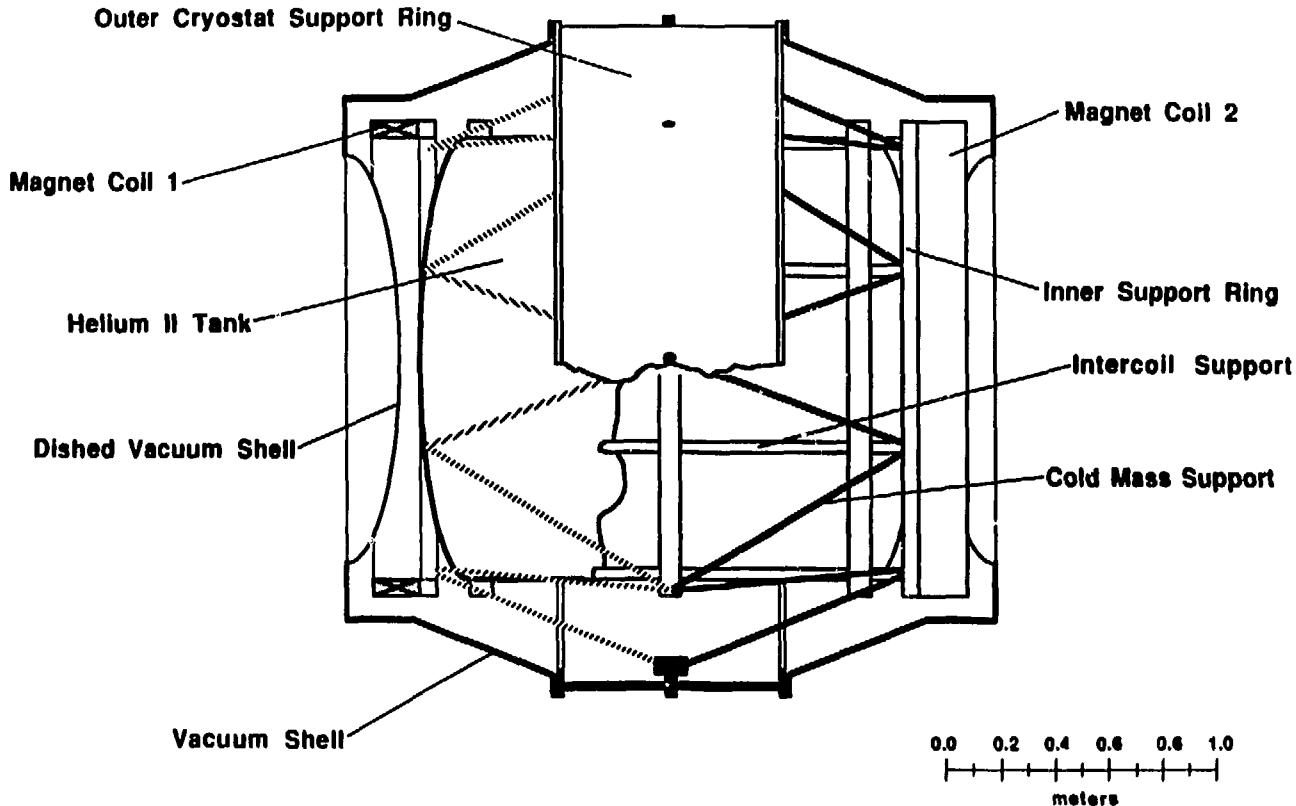

Figure 2

ASTROMAG HEAO TYPE MAGNET with a Cylindrical Helium Storage Tank and 1.7 meter Diameter Coils



The coil design parameters shown in Table 3 do push the state of the art somewhat. A coil test program at the Lawrence Berkeley Laboratory is expected to set the operating limits for the ASTROMAG magnet coils and cryogenic system.¹⁴ It is hoped that the ASTROMAG magnet stored energy can be increased to values more than the design value of 11 MJ without increasing the cold mass or overall mass of the ASTROMAG magnet system. Physics resolution will be improved as the square root of magnet stored energy for a given magnet and experiment configuration. One can also improve the resolution of the experiment by moving the experiment as close to the superconducting coils as possible. Current design parameters call for the magnet coil being located 10 centimeters from the nearest particle detector. It is clear that there is a trade off between the coil to experiment separation and heat leak into the magnet cryogenic system (the storage life of the coolant cryogen).

Both coils shown in Table 3 use similar multi-filamentary niobium titanium. The superconductor is in a copper matrix with a copper to superconductor ratio of about 1.8 to 1. The filament diameter in both cases is less than 30 microns. The matrix resistivity at 1.8 K is designed to be about 10^{-9} ohm meters. The niobium titanium critical current density is set at 2500 A mm^{-2} at 4.2 K and 5 T. Reducing the temperature at 1.8 K improves critical current density. The niobium titanium superconductor proposed for both types of magnets is entirely within the state of the art. At design current and temperature, the magnet will be operating at less than 50 percent of its critical current.

THE SUPERFLUID HELIUM COOLING SYSTEM

Superfluid helium is the stored cryogen of choice for superconducting magnets in space as it is for various low noise squib detectors and various short wavelength rf detectors. The use of superfluid helium for cooling has a number of important advantages for cooling large superconducting magnets in space. These advantages are:

- 1) A temperature of 1.8 K is easy to obtain and maintain in space. The vacuum pumping needed to maintain superfluid helium is provided by space itself.
- 2) The liquid density is higher for superfluid helium than helium at its 1 atm boiling temperature of 4.2 K. As a result, the tanks can be made somewhat smaller per unit helium mass.
- 3) Superfluid helium has a higher heat of vaporization, but there is little difference in available total refrigeration between superfluid helium and helium at 4.2 K (about 12 J g^{-1} or less than one percent).
- 4) Complete gas-liquid phase separation can be obtained in a weightless-environment using a porous plug. Taking only helium gas into the leads and shields will reduce overall helium consumption.

- 5) Superfluid helium can be pumped through the magnet coils using the fountain effect. There are no moving parts in the pump and the heat needed to drive the pump is supplied by heat leaks into the system.
- 6) The critical current density in the superconductor is higher at 1.8 K than it is at 4.2 K. There is an additional margin when operating at 1.8 K or one can increase the magnetic induction at the superconductor.

Figure 3 is a schematic diagram of an all helium cryogenic system for the ASTROMAG superconducting magnet.¹² Some of the cold valves, cold burst discs and the crossover plumbing associated with ground operations and shuttle safety requirements have been omitted to provide a clear picture of the basic cryogenic system. Figure 3 shows a thermomechanical helium II pump for circulating superfluid helium through the superconducting coils and the persistent switch. One design for a superfluid helium pump is illustrated in Figure 4. The pump developed and tested by Hofmann¹⁵ uses an extra heat exchanger to heat the downstream side of the porous plug. The Hofmann type pump can pump up to 3 gs^{-1} using the fountain effect which is driven by heat deposited on the piece to be cooled. Figure 3 shows how the boil-off gas can be used to cool the retractable gas-cooled electrical leads, the radiation shields and cold mass support heat intercepts. Figure 5 shows in more detail the cooling circuit for the retractable gas cooled electrical leads and shields.

The two shield concept shown in Figure 3 is similar to the HEAO cryostat¹¹ of the early 70's except that the gas cooled leads are at both ends of the shield gas flow circuit. The gas cooled leads will disconnect in the middle. The proposed leads are enhanced heat transfer leads which can be operated at any orientation in a vacuum.¹⁶ When the leads are connected together and operating, the shields and intercepts will run colder than normal. As a result, some of the refrigeration lost during charging or discharging of the magnet can be recovered. The estimated lifetime of a full tank of helium is around 2 years for the cryogenic system shown in Figure 3. This estimated cryogenic lifetime includes allowances for four coil charges and discharges per year.

The cryogenic system shown in Figure 3 is designed so that the magnet coils can be cooled down, from the storage tank, in the event of a quench. About 50 kg of helium is required to recover from a magnet quench when the stored energy is 11 MJ.

The coils, persistent switch and the tank can be cooled down from room temperature using liquid helium pumped from a large external storage tank on the ground. The proposed cryogenic system for ASTROMAG will permit the helium storage tank to be refilled periodically by a tanker brought up from earth. This concept is scheduled to be tested by the SHOOT experiment sometime in 1991 or 1992.¹⁷ The use of orbital transfer of helium will permit the ASTROMAG experiment to operate on the space station for many years.

Figure 3
MAGNET CRYOGENIC SYSTEM
SINGLE ALL HELIUM FLOW CIRCUIT
During Normal Operation at 1.8 K

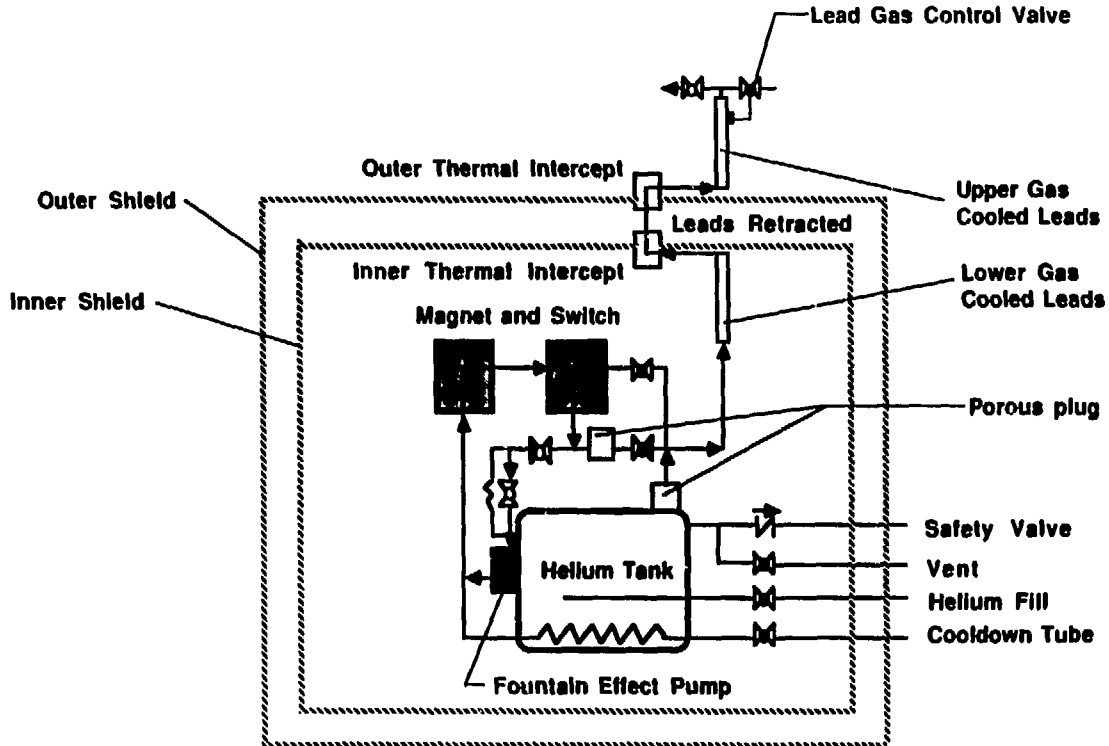

Thermomechanical Pump for Astromag

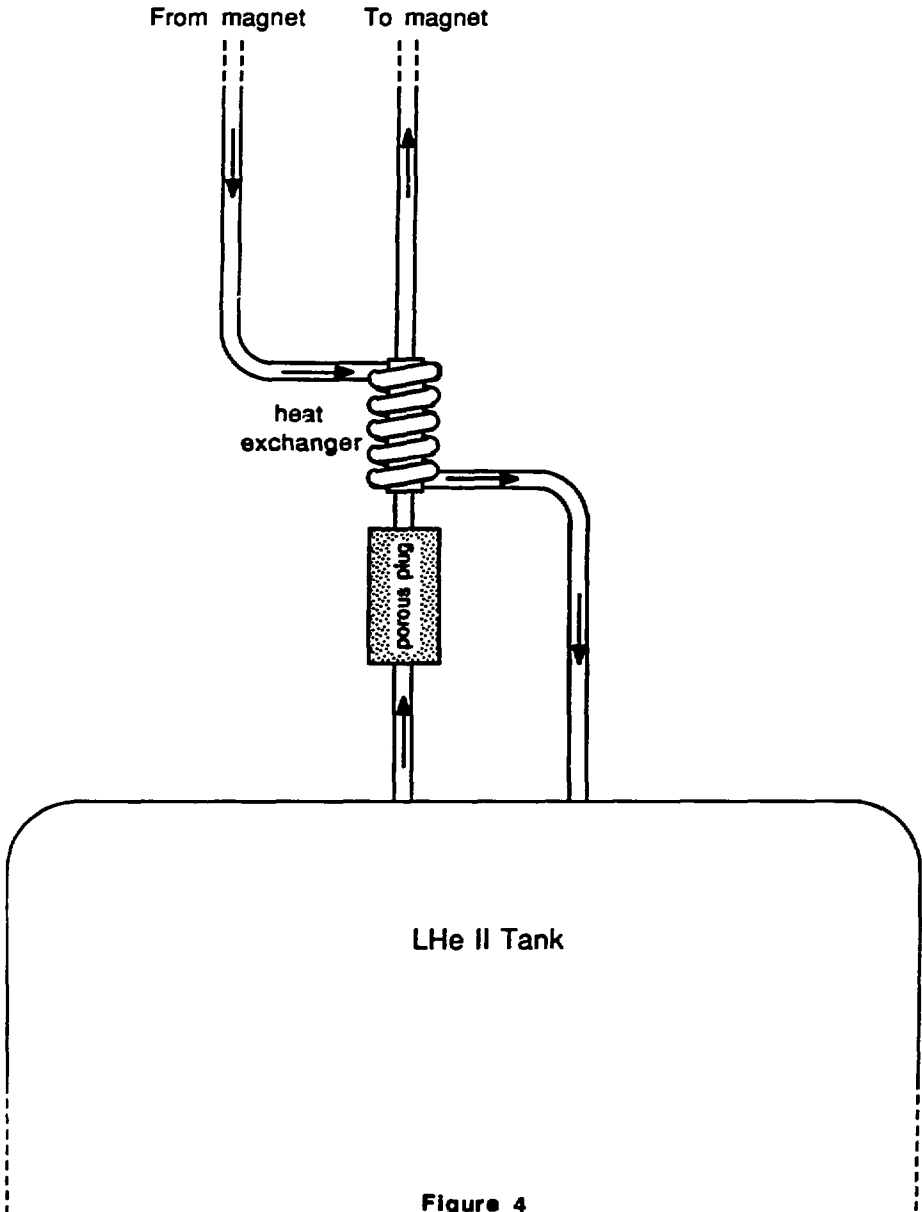

Figure 4

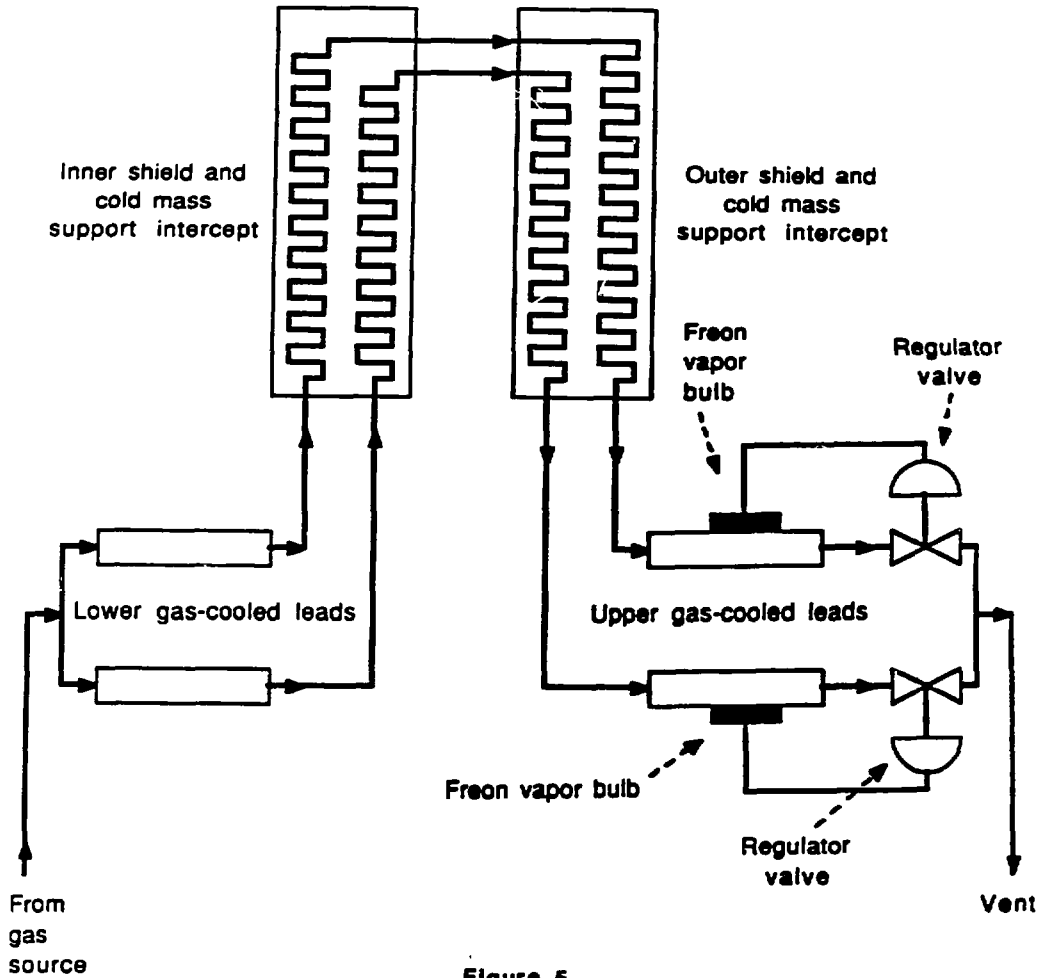

Figure 5
Gas-Cooled Lead and Shield Circuit

ALTERNATIVE CRYOGENIC SYSTEMS FOR ASTROMAG

The cryogenic system shown in Figure 3 with details in Figures 4 and 5 has a projected lifetime of about two years. This means that the tanker must be dispatched to the Space Station every 18 months or so to resupply ASTROMAG with liquid helium.¹⁸ Since a shuttle launch is expensive, it is desirable to extend the helium inventory storage time. Since ASTROMAG will draw power and cooling from the space station, the use of mechanical refrigeration can be considered.

The heat entering the ASTROMAG cryostat shown in Figures 1 and 2 is approximately 4 Watts. Most of this heat is intercepted by the helium gas flowing out of the tank through the electrical leads gas cooled shields and cold mass support strut thermal intercepts. As a result, only about 0.16 W enters the 1.8 K cryogenic system (except when the magnet is charged or discharged). If mechanical cooling at 1.8 K is used, the whole 4 W must be removed at that temperature. The estimated input power (based on the Strobridge curves¹⁹) is about 20 kw. This power must not only be supplied by the Space Station, but most of this energy must be rejected into space. Even if a reliable cryocooler which operates at 1.8 K existed, it would not be reasonable to use 40 percent of the space station's power capacity to cool a single experiment.

If the heat is intercepted at a higher temperature, one can reduce the required input power (and heat rejected) and one can reduce the heat input into the helium and the helium consumption. If the ASTROMAG cryostat has a third shield and cold mass support intercept point at 80 to 90 K, the heat flow into the 1.8 K region of the cryostat can be reduced almost a factor two thus extending the helium storage time out to about 3.6 years from 2 years. There are some commercial cryocoolers which operate in the range from 70 to 100 K. If one wants to remove about 4 Watts at 90 K, about 150 W of Space Station power is required.²⁰

Figure 6 shows the ASTROMAG cryogenic system with a third (outer) 90 K shield which is cooled by four 1 to 1.2 W mechanical coolers. The two inner shields are cooled by the helium boiled off. This helium cools the leads and intercepts most of the heat from the refrigerated outer shield and cold mass support intercept (about 1 Watt). The heat entering the helium at 1.8 K is reduced to about 0.09 W (except during a coil charge and discharge). The added mass for the four cryocoolers is about 34 kg (including electronics).²⁰

A second approach to reducing helium consumption is the hybrid cryogenic system where the heat is intercepted by a boiling or subliming cryogen at its boiling or sublimation point. From Table 2, it is clear that the only cryogen which makes sense as a second fluid is hydrogen in either liquid or solid form. Fluids such as neon and nitrogen would not be attractive because the total available refrigeration is less than that of helium. Hydrogen, on the other hand, has three times available refrigeration of helium so the total mass of cryogen (both fluids) should be reduced considerably over an all cryogenic helium system.

Figure 6
MAGNET CRYOGENIC SYSTEM
WITH THIRD REFRIGERATED SHIELD
During Normal Operation at 1.8 K

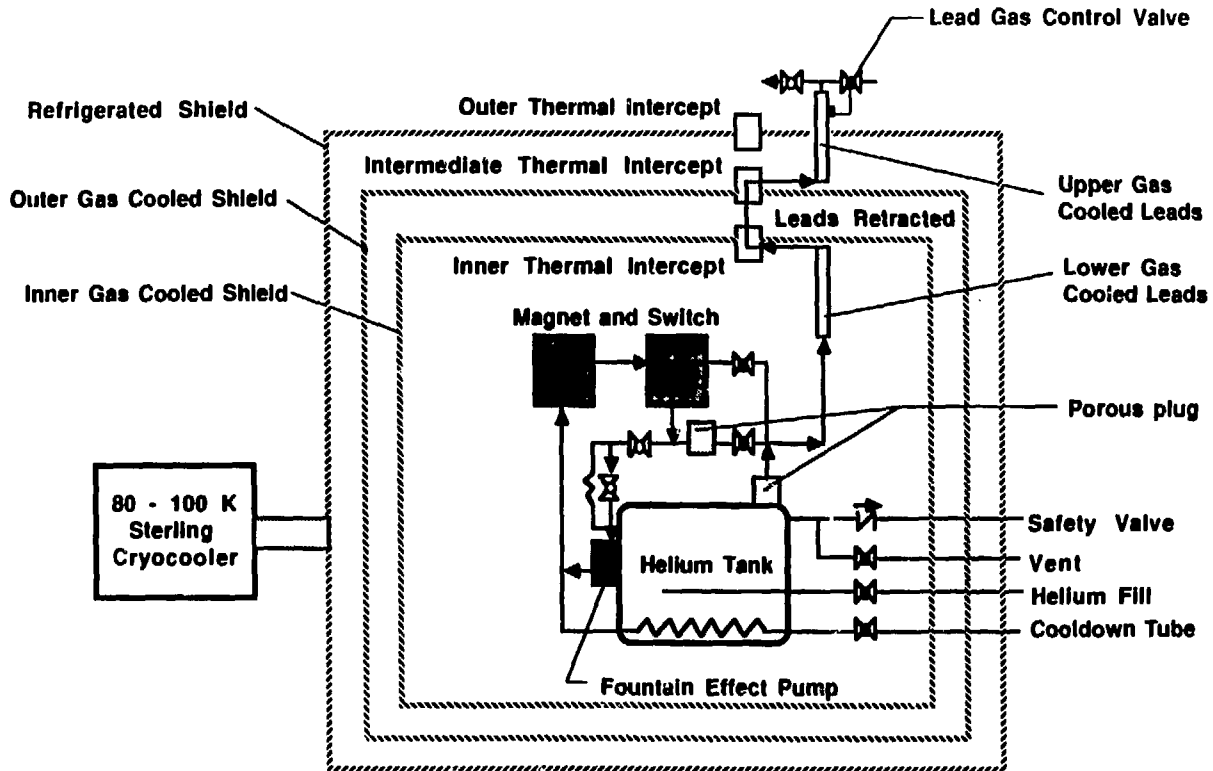

Two problems must be considered when one looks at the hybrid hydrogen-helium cryogenic system for ASTROMAG. The first problem is the extreme flammability of hydrogen. Under current safety regulations, the use of liquid hydrogen is prohibited on the shuttle or the space station. If ASTROMAG were launched by an expendable launch vehicle and the experiment were a freeflying experiment, the hybrid cryogenic system would be attractive if the weight of the extra tankage was less than the liquid cryogen saved from the all helium system. The second problem is design of this tankage and the phase separation of the hydrogen being used to cool the shields and intercepts.

Figure 7 shows a schematic of a hybrid cryogenic system using either liquid hydrogen (at 16 K) or solid hydrogen (at 13 K). The gas from the hydrogen evaporation is used to cool the two outer shields and cold mass support intercepts. The inner shield and support intercept is attached directly to the tank. The heat leak into the hydrogen increases to about 0.4 W because the two outer shields and cold mass support intercept points will run hotter (the ratio of sensible heat to latent heat is 9.5 for hydrogen compared to about 68 for superfluid helium). Even with a heat input to the hydrogen tank of 0.4 W, the mass flow of hydrogen through the shields would only be 0.0009 gs^{-1} (compared to 0.0069 gs^{-1} for an all helium cryogenic system).

Helium consumption when the magnet is operating in the persistent mode would be reduced about factor of five as compared to an all helium cryogenic system (most of the remaining heat leak is due to instrumentation wiring and the remaining heat leak down the lower gas cooled leads). Magnet charging and discharging four times a year is expected to consume 7-8 kg per year of helium as in the all helium cryogenic system. Between 12 and 15 percent of the stored helium would be used for the four annual magnet charges and discharges. One might argue that a free flying ASTROMAG does not have to be charged and discharged four times a year but for comparison sake in Table 4 one assumes that all three magnet cryostats have the magnet charged and discharged 4 times a year.

The hybrid cryostat can be designed with a lifetime approaching 4 years. It is estimated that the hybrid cryostat would consume 208 kg of helium and about 118 kg of liquid or solid hydrogen over a four year period. Figure 8 shows a hybrid cryostat ASTROMAG with a superfluid cylindrical helium dewar inside of an annular hydrogen cryostat. The coil outside diameter in this case is 1.3 meters so that the intercoil supports pass between the helium and hydrogen tanks. The coil separation is comparable to the case shown in Figure 1 and Table 3. Table 4 compares projected heat leaks and cryogen consumptions for the all helium cryostat, helium cryostat with 80 K cryocooler, and a hybrid hydrogen helium cryostat. The heat leaks and cryogen consumption figures should be regarded as preliminary engineering estimates. It is estimated that all three ASTROMAG 11 MJ magnets and cryostats can be built with a total mass including the cryogens of about 2000 kg.

Figure 7

MAGNET CRYOGENIC SYSTEM HYBRID SYSTEM WITH HYDROGEN COOLED SHIELDS During Normal Operation at 1.8 K

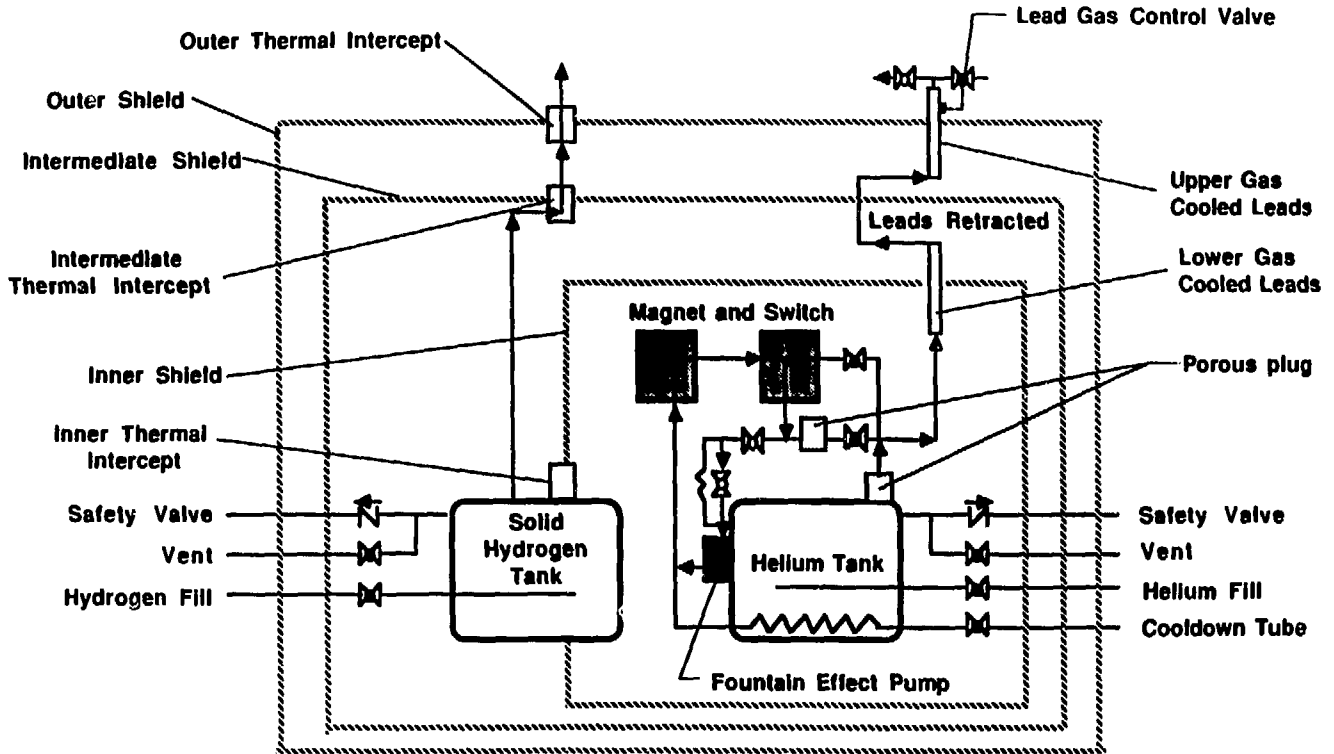

Figure 8

HYBRID ASTROMAG HEAO TYPE MAGNET with Cylindrical Helium and Hydrogen Storage Tanks and 1.3 meter Diameter Coils at 1.8 K

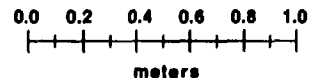
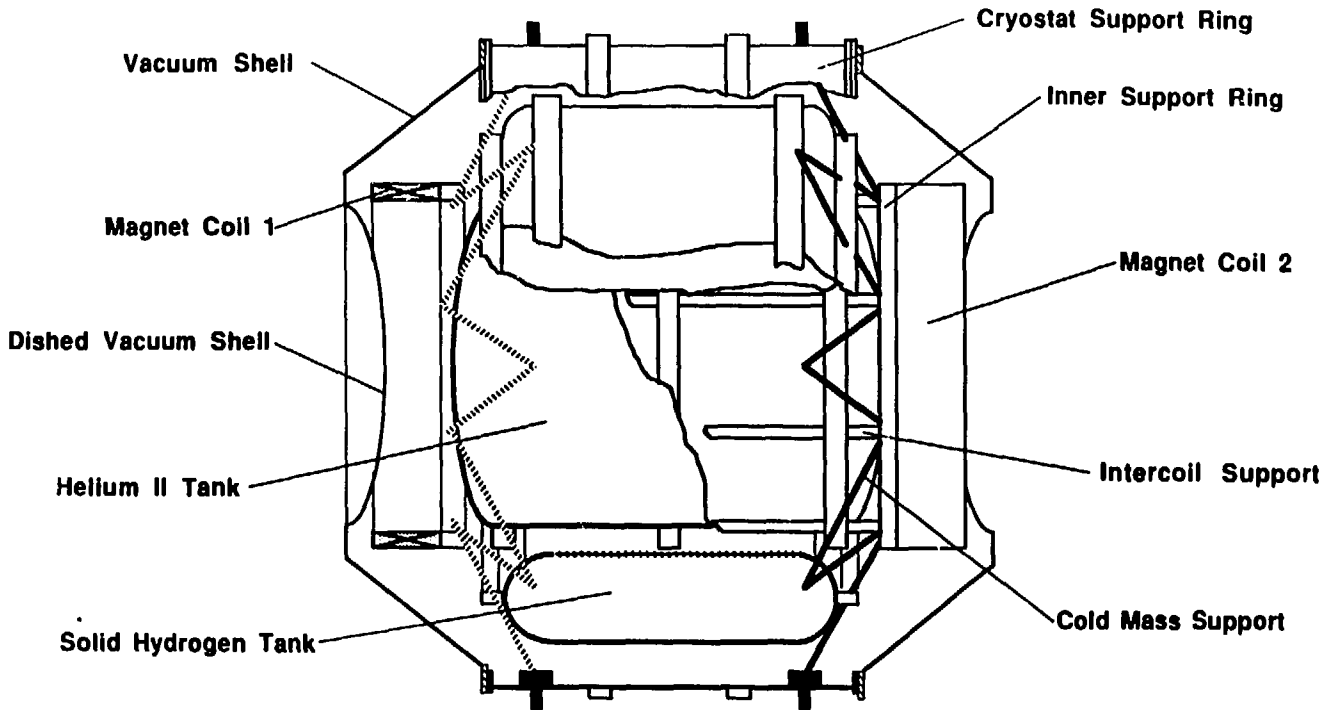

Table 4. Heat Leak and Cryogen Boiloff Rates for Various ASTROMAG Magnet Systems

| | All Helium Cryostat | Helium Cryostat with Refrigerated Shield | Hybrid Cryostat |
|---|---------------------|--|-----------------|
| Liquid Helium Inventory* (kg) | 468 | 468 | 218 |
| Heat Leak to 1.8 K (W) | 0.160 | 0.090 | 0.032 |
| Helium Boiloff (kg yr ⁻¹) | 226 | 131 | 52 |
| Liquid Hydrogen Inventory* (kg) | -- | -- | 117 |
| Heat Leak to H ₂ Tank (W) | -- | -- | 0.4 |
| Hydrogen Boiloff (kg yr ⁻¹) | -- | -- | 29 |
| Cryostat Life (yr) | 2.07 | 3.57 | 4.07 |

*The tank is 90 percent full.

ACKNOWLEDGMENTS

The author would like to thank J. F. Ormes, G. F. Smoot, R. L. Golden, and M. E. Wiedenbeck for their comments on the physics resolution of various magnet systems. The author also acknowledges the fruitful discussions he has had with S. Castles and A. Hofmann on fountain effect superfluid helium pumping systems.

This work was supported by the Office of Astrophysics, NASA and the Office of Basic Energy Science, U.S. Department of Energy, under Contract No. DE-AC03-76SF00098.

REFERENCES

- 1) "Report of the Astromag Definition Team, The Particle Astrophysics Facility, ASTROMAG, NASA-GSFC, Greenbelt, MD, May 1988.
- 2) M. A. Green et al., IEEE Transactions on Magnetics MAG-23, No. 2, p. 1240 (1987).
- 3) J. G. Bednorz and K. A. Muller, Z. Phys. B 64, p. 189 (1986).
4. M. K. Wu et al., "Superconductivity at 95 K in a Mixed Phase Y-Ba-Cu-O Compound System at Ambient Pressure," Phys. Rev. Letter 58, p. 908 (1987).
5. D. S. Easton and C. C. Koch, Advances in Cryogenic Engineering 22, p. 453, Plenum Press, New York (1976).
6. H. M. Ledbetter, "Elastic Constants of Y-Ba-Cu-O Superconductors" to be published Proceedings of the MRS International Meeting on Advanced Materials (Tokyo, May-June 1988).
7. E. N. Collings, "Flux Jump Stability and Cryogenic Stability for Superconductor for 80 K" to be published. Proceedings of the MRS International Meeting on Advanced Materials (Tokyo, May-June 1988).
8. M. A. Green, "High T_c Superconductor and its Use in Superconducting Magnets", LBL-23946 (1988).
9. V. J. Johnson, The WADD Compendium, Pergamon Press, New York (1961).
10. E. G. Birentari and R. V. Smith, Advances in Cryogenic Engineering 10, p. 325, Plenum Press, New York (1964).
11. W. L. Pope et al., Advanced in Cryogenic Engineering 20, p. 47 (1974).
12. M. A. Green and S. Castles, Advances in Cryogenic Engineering 33, p. 631, Plenum Press, New York (1987).
13. M. A. Green et al., IEEE Transaction Magnetics MAG-24, No. 2, p. 1015 (1988).
14. M. A. Green et al., presented at the ICEC-12 Conference, Southampton, UK, 12-15 July 1988.

15. A. Hofmann et al., *Advances in Cryogenic Engineering* **33**, p. 471, Plenum Press, New York (1987).
16. R. G. Smits et al., *Advances in Cryogenic Engineering* **22**, p. 169, Plenum Press, New York (1981).
17. M. D. Pirro and S. Castles, *Cryogenic* **26**, No. 2, p. 84 (1986).
18. M. A. Green, "Superconducting Magnet Technique for ASTROMAG on the Space Station" to be published in the *Journal of the Societa Italiana di Fisica*.
19. T. R. Strobridge, *IEEE Transactions on Nuclear Science* **NS-15**, No 3, p. 1104 (1969).
20. Sales brochure for a British Aerospace Mechanical (Sterling Cycle) Cryocooler for Space Applications.

Figure Captions

- Figure 1** HEAO Type ASTROMAG Magnet with a Spherical Helium Tank and 1.3 Meter Diameter Coils
- Figure 2** HEAO Type ASTROMAG Magnet with a Cylindrical Helium Tank and 1.7 Meter Diameter Coils
- Figure 3** Magnet Cryogenic System with a Single All Helium Flow Circuit
- Figure 4** Open Cycle Thermomechanical Helium Pump to Cool the ASTROMAG Coils
- Figure 5** ASTROMAG Gas Cooled Lead Shield and Intercept Flow Circuit
- Figure 6** Magnet Cryogenic System with a Third Refrigerated Shield
- Figure 7** Hybrid Magnet Cryogenic System with Hydrogen Cooled Shields
- Figure 8** Hybrid ASTROMAG Magnet with Cylindrical Helium and Hydrogen Tanks and 1.3 Meter Diameter Coils at 1.8K