

CONF-890403--3

DE89 011242

RECENT ELECTRON TEMPERATURE AND DENSITY RESULTS
FROM THE ATF THOMSON SCATTERING SYSTEM

D.A. Rasmussen, A.C. England, M. Murakami, H.C. Howe, T.L. Clark,
R.R. Kindsfather*, T.M. Rayburn, K.A. Stewart, P.S. Rogers
Oak Ridge National Laboratory
Oak Ridge, Tennessee 37831, U.S.A.

G.L. Bell
Auburn University, Auburn, Alabama 46849, U.S.A.

P.L. Shaw and C.E. Thomas
Georgia Institute of Technology, Atlanta, Georgia 30332, U.S.A.

For the
Seventh International Workshop on Stellarators
Oak Ridge, Tennessee 37831

April 10-14, 1989

*Present address: Igen, Inc., Rockville, MD 20852

Research sponsored by
the Office of Fusion Energy
U.S. Department of Energy
under contract DE-AC05-84OR21400
with
Martin Marietta Energy Systems, Inc.
Oak Ridge, Tennessee 37831

DISCLAIMER

This report was prepared as an account of work sponsored by an agency of the United States Government. Neither the United States Government nor any agency thereof, nor any of their employees, makes any warranty, express or implied, or assumes any legal liability or responsibility for the accuracy, completeness, or usefulness of any information, apparatus, product, or process disclosed, or represents that its use would not infringe privately owned rights. Reference herein to any specific commercial product, process, or service by trade name, trademark, manufacturer, or otherwise does not necessarily constitute or imply its endorsement, recommendation, or favoring by the United States Government or any agency thereof. The views and opinions of authors expressed herein do not necessarily state or reflect those of the United States Government or any agency thereof.

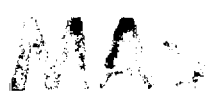

Recent Electron Temperature and Density Results from the ATF Thomson Scattering System

RASMUSSEN, D.A., ENGLAND, A.C., MURAKAMI, M., HOWE, H.C., CLARK, T.C., KINDSFATHER, R.R., RAYBURN, T.M., ROGERS, P.S., STEWART, K.A.,

Oak Ridge National Laboratory, Oak Ridge, Tennessee

BELL, G.L.,

Auburn University, Auburn, Alabama

SHAW, P.L., THOMAS, C.E.,

Georgia Institute of Technology, Atlanta, Georgia

United States of America

ABSTRACT. A spatial multipoint Thomson scattering system has been developed for the Advanced Toroidal Facility (ATF) torsatron. The system measures temperature and density at 15 vertical locations on a vertical chord for each laser shot (one per plasma discharge). By remotely relocating the laser beam and reconfiguring the viewing optics during a series of ATF discharges, a two-dimensional (2-D) electron temperature and density map of the plasma cross section can be obtained. Results obtained with this system during ATF operation in 1988 and early 1989 are presented.

INTRODUCTION

The Thomson scattering system for the ATF [1] can provide a 2-D profile of the electron temperature and density by shot-to-shot horizontal translation of the vertically directed ruby laser beam coupled with a repointing of the viewing optics [2]. A sketch of the Thomson scattering system is shown in Fig. 1. The source light for Thomson scattering is provided by a single-pulse ruby laser (made by Quantel Inc.). The

maximum output energy is 25 J. Typical laser shots deliver 13 J to the scattering volume with a pulse width of 40 ns (FWHM). Laser energy is measured on each shot. To obtain T_e and n_e scans, the laser beam is translated along a major radius ($\phi = 0$ plane) between plasma discharges. The beam is focused with a 7-m focal length lens to a diameter of 2.1 mm at the ATF midplane. The scattered light is viewed through a toroidally offset port at the ATF midplane (Fig. 2). The viewing optics relay the scattered laser light onto a vertical image plane, which is coupled via fiber-optic bundles to a maximum of 15 spectrometers. The fibers receive light from a 24-mm segment of the laser beam in the plasma. Each spectrometer has from five to eight output channels, depending on the particular grating used. The output of the spectrometer channels is coupled via optical fibers to an array of approximately 105 photomultiplier tubes. The viewing optics track the laser beam by means of the set of rotating and translating mirrors shown in Fig. 2. The complex shape of the ATF vacuum vessel means that the different scattering positions in the plasma have varying levels of reflected stray laser light and plasma radiation light. The restricted viewing angle, limited access to the ATF device, and measurement on the red side of the spectrum result in an overall collection efficiency (detected photoelectrons) for scattered light of 0.24% for our arrangement.

PHASE II RESULTS (MAY–SEPTEMBER 1988)

During this phase of ATF operations, the Thomson scattering system could obtain data from only one vertical chord and from seven vertical scattering volumes. ATF was operated during this period with known field errors [3, 4]. The largest magnetic field islands (~6 cm wide) were present at the $t = 1/2$ surface ($r/a \sim 0.6$). Figure 3 shows electron temperature data obtained during second harmonic electron cyclotron heating (ECH) operation of ATF (53 GHz, 0.2 MW at 0.95 T). The temperature profile represents the average of data obtained at $t = 0.190$ s from 28 identical discharges. The laser chord was located at 210 cm for these discharges. The data are mapped to flux coordinates (ρ) using a finite- β equilibrium [5, 6] ($\beta(0) \sim 1\%$). For this narrow temperature profile, the central flux surface shifts approximately 4 cm outward from its

vacuum field location ($R = 205$ cm). The central temperature and profile shape are representative of other times during the quasi-steady-state phase of ECH pulses.

Data were also obtained during 1.4 MW balanced neutral beam injection (NBI) operation [4] for the phase II operating period. The temperature profile shown in Fig. 4(a) is from measurements made at $t = 0.265$ s along a chord at $R = 209$ cm. Figure 4(b) shows the data plotted in a flux coordinate system based on a finite- β equilibrium [5, 6] of $\beta(0) = 3\%$. The vacuum and the finite- β equilibrium used to obtain the flux surfaces are shown in Fig. 5. The central flux surface shifts approximately 11 cm outward from its vacuum field location ($R = 205$ cm). This narrow profile shape was obtained during all NBI discharges. The time evolution of the electron temperature for a typical 1.4 MW NBI discharge is shown in Fig. 6(a). The data points were obtained from averages of multiple discharges of the central channel of Thomson scattering. The solid line is derived from measurements of the central third harmonic electron cyclotron emission [7] (ECE) normalized to a Thomson scattering value at one time. The line-averaged density, central and volume-averaged β , and input power (ECH and NBI) for these discharges are shown in Fig. 6(b). The density rises with application of NBI and the electron temperature, after an initial drop, increases until approximately 0.265 s, at which time the diamagnetic stored energy reaches a peak. The plasma undergoes a radiative collapse at $t = 0.300$ s, as indicated by the sudden decrease in the line-averaged density.

Electron density measurements were made during this period of operation. Density calibration was obtained by the standard technique of Rayleigh scattering. For both ECH and NBI operation, the density profile was slightly broader than the electron temperature profile. The density profile for the 1.4 MW NBI case discussed above is plotted in real space and flux coordinates in Figs 4(c) and 4(d). Good agreement was obtained when the line-integrated density ($n_e \ell$) from 2 mm interferometry was compared to the integrated density from Thomson scattering.

EARLY PHASE III RESULTS (FEBRUARY–MARCH 1989)

Prior to phase III operation of ATF, the current feeds were modified in order to reduce the field errors. As of the date of this meeting, the Thomson scattering system can obtain data from 13 vertical scattering volumes at 5 vertical chords. Alignment measurements now in progress will allow data collection from an arbitrary number of vertical chords.

At this writing, plasma operation for phase III has been with only one NBI source. Because of the limited time of operation, optimized plasma conditions have not yet been obtained. Preliminary results from this period of operation indicate broader electron temperature and density profiles. The maximum electron temperatures remain lower than for equivalent phase II operation. Absolute density calibration for this operating period has not yet been obtained.

ACKNOWLEDGEMENTS

The authors acknowledge valuable discussions with E.A. Lazarus, J.B. Wilgen, and W.R. Wing. We thank the ATF operations and data acquisition groups for their cooperation. We also thank J.L. Dunlap, R.C. Isler, J.F. Lyon, and G.H. Neilson for their encouragement and support.

This work was sponsored by the Office of Fusion Energy, U.S. Department of Energy, under contract DE-AC05-84OR21400 with Martin Marietta Energy Systems, Inc..

REFERENCES

- [1] LYON, J.F., CARRERAS, B.A., CHIPLEY, K.K., et al., Fusion Technol. 10, (1986) 179.
- [2] KINDSFATHER, R.R., RASMUSSEN, D.A., MURAKAMI, M., et al., Rev. Sci. Instrum. 57, (1986) 1816.
- [3] COLCHIN, R.J., HARRIS, J.H., ANDERSON, F.S.B., et. al., Controlled Fusion and Plasma Physics (Proc. 16th Eur. Conf., Venice, 1989), Vol. 13B, Part II, European Physical Society (1989) 615..

- [4] MURAKAMI, M., CARRERAS, B.A., HARRIS, J.H., et. al., *ibid.*, p. 575; HARRIS, J.H., MURAKAMI, M., CARRERAS, B.A., et. al., submitted to *Phys. Rev. Lett.*
- [5] HIRSHMAN, S.P., WHITSON, J.C., *Phys. Fluids* **26**, (1983) 3553,
- [6] HOWE, H.C., HORTON, L.D., CRUME, E.C., et. al., Transport modeling of ECH and neutral-beam-heated plasmas in the Advanced Toroidal Facility, paper 1P-3 presented at this conference.
- [7] BELL, G.L., GANDY, R.F., WILGEN, J.B., RASMUSSEN, D.A., *Rev. Sci. Instrum.* **59**, (1988) 1614.

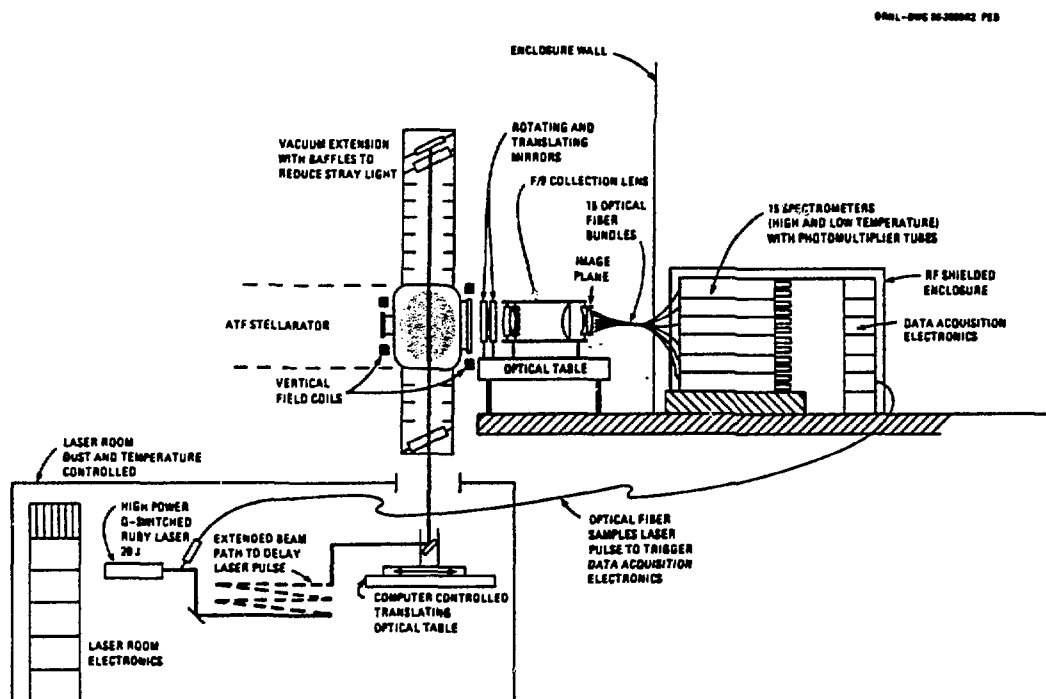

FIG. 1. The ATF Thomson scattering system outline.

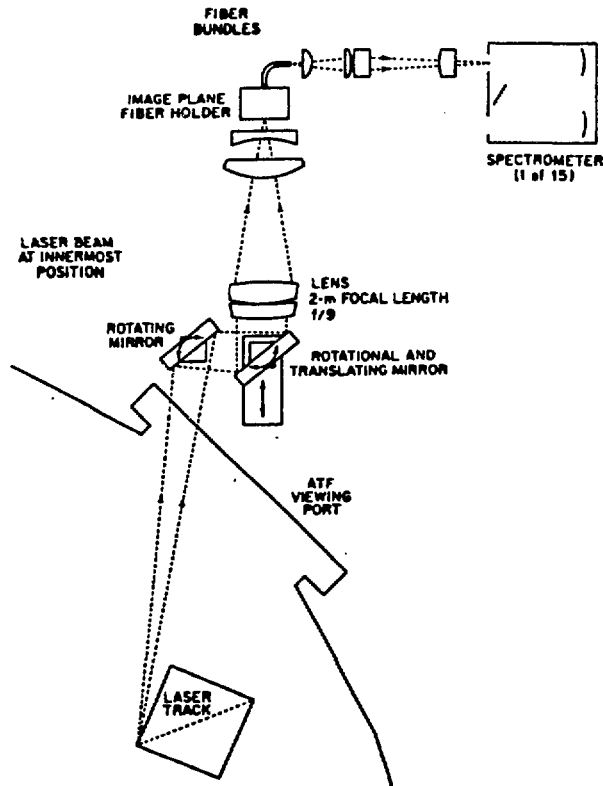

FIG. 2. Viewing optics layout.

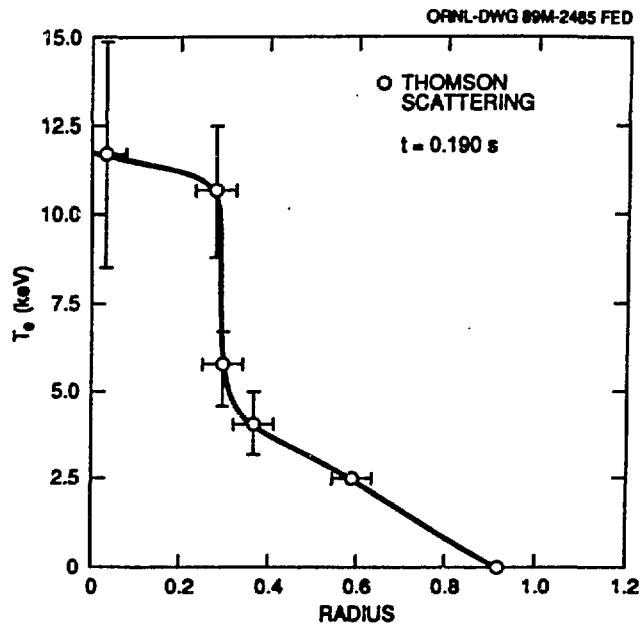

FIG. 3. Electron temperature profile obtained at $t = 0.190$ s for 200 kW, 53 GHz ECH operation. Data are averaged from 28 identical discharges. Data are mapped to flux surfaces using a finite- β equilibrium with $\beta(0) = 1\%$.

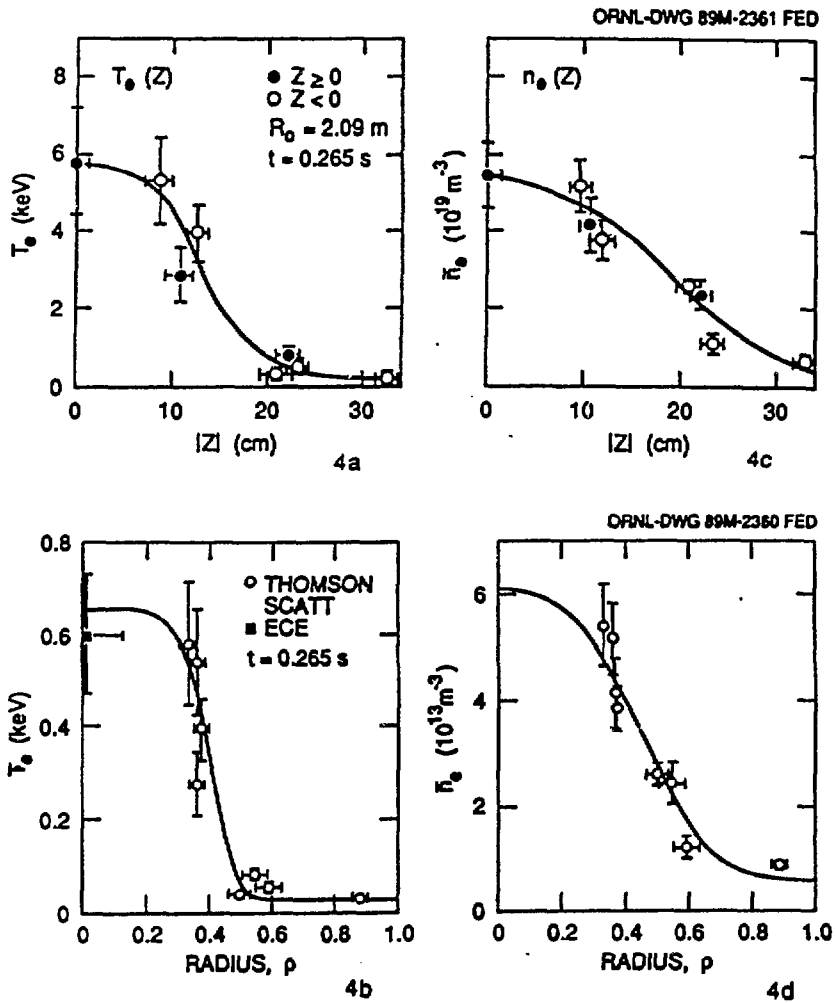

FIG. 4. Electron temperature measured (a) along a vertical chord ($|Z|$) and (b) as a function of flux coordinate (ρ), and electron density measured (c) along a vertical chord ($|Z|$) and (d) as a function of flux coordinate (ρ). All plots are for 1.4 MW NBI at $t = 0.265$ s.

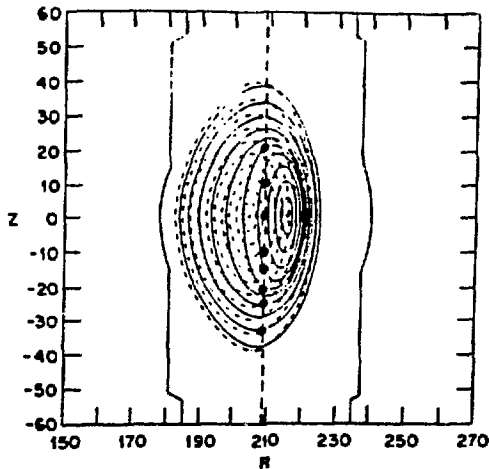
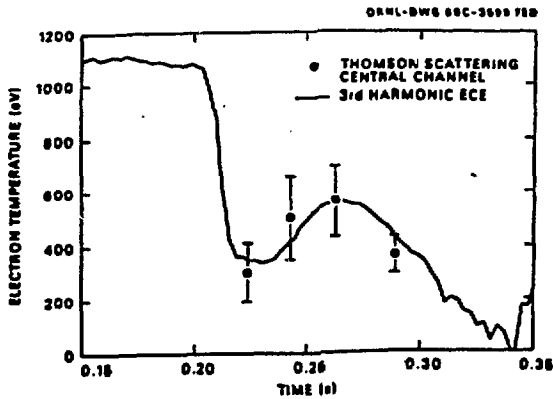
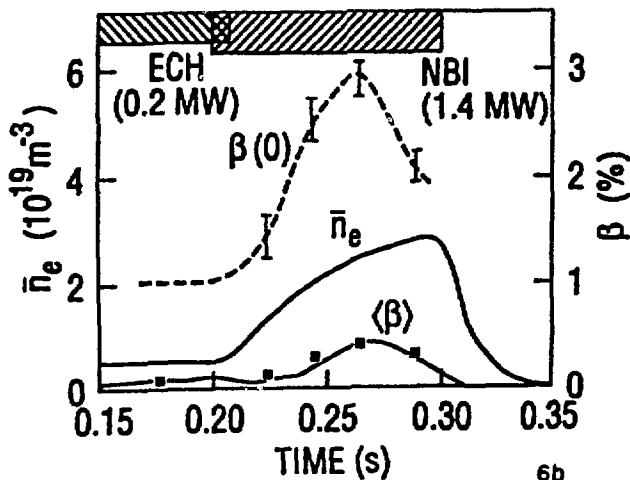

FIG. 5. The vacuum (dashed) and finite- β (solid) equilibrium [5, 6] for the data of Figs 4 and 6 at $t = 0.265$ s. The laser chord and the viewed scattering volumes are also indicated.



6a

FIG. 6. (a) Time evolution of the electron temperature during 1.4 MW balanced NBI. The data points are obtained from Thomson scattering; the solid line is from third harmonic ECE [7]. The ECE signal is normalized to Thomson scattering at $t = 0.265$ s. (b) Line-averaged density, central and volume-averaged β , and input power (ECH and NBI) for 1.4 MW balanced NBI discharges.



6b