

2  
**MASTER**

*EGG*/SEMI-TR-006  
for U.S. Nuclear Regulatory Commission

**EXPERIMENT DATA FOR DETERMINATION OF  
UNCERTAINTY OF TWO-PHASE MASS FLOW RATE IN A  
SEMISCALE MOD-3 SYSTEM SPOOL PIECE AT  
KARLSRUHE KERNFORSCHUNGSZENTRUM**

ALAN G. STEPHENS

June 1979



**EG&G** Idaho, Inc.



IDAHO NATIONAL ENGINEERING LABORATORY

**DEPARTMENT OF ENERGY**

IDAHO OPERATIONS OFFICE UNDER CONTRACT DE-AC07-76IDO1570

DISTRIBUTION OF THIS DOCUMENT IS UNLIMITED

## **DISCLAIMER**

**This report was prepared as an account of work sponsored by an agency of the United States Government. Neither the United States Government nor any agency thereof, nor any of their employees, makes any warranty, express or implied, or assumes any legal liability or responsibility for the accuracy, completeness, or usefulness of any information, apparatus, product, or process disclosed, or represents that its use would not infringe privately owned rights. Reference herein to any specific commercial product, process, or service by trade name, trademark, manufacturer, or otherwise does not necessarily constitute or imply its endorsement, recommendation, or favoring by the United States Government or any agency thereof. The views and opinions of authors expressed herein do not necessarily state or reflect those of the United States Government or any agency thereof.**

---

## **DISCLAIMER**

**Portions of this document may be illegible in electronic image products. Images are produced from the best available original document.**

EXPERIMENT DATA FOR DETERMINATION OF  
UNCERTAINTY OF TWO-PHASE MASS FLOW RATE IN A  
SEMISCALE MOD-3 SYSTEM SPOOL PIECE AT  
KARLSRUHE KERNFORSCHUNGSZENTRUM

by

A. G. Stephens

SEMISCALE PROGRAM

June 1979

Approved: \_\_\_\_\_

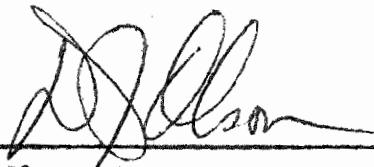
  
D. J. Olson, Manager  
Semiscale Program

Approved: \_\_\_\_\_

  
L. D. Watson, Manager  
Measurement Engineering and Experimental Instrumentation Branch

NOTICE  
This report was prepared as an account of work sponsored by the United States Government. Neither the United States nor the United States Department of Energy, nor any of their employees, nor any of their contractors, subcontractors, or their employees, makes any warranty, express or implied, or assumes any legal liability or responsibility for the accuracy, completeness or usefulness of any information, apparatus, product or process disclosed, or represents that its use would not infringe privately owned rights.

DISTRIBUTION OF THIS DOCUMENT IS UNLIMITED

**INTERIM REPORT**Accession No. \_\_\_\_\_  
Report No. SEMI-TR-006**Contract Program or Project Title:**  
Semiscale**Subject of this Document:** "Experiment Data for Determination of Uncertainty of Two-Phase Mass Flow Rate in a Semiscale Mod-3 System Spool Piece at Karlsruhe Kernforschungszentrum"**Type of Document:**  
Data Report**Author(s):**  
Alan G. Stephens**Date of Document:**  
June 1979**Responsible NRC Individual and NRC Office or Division:**  
W. D. Lanning, NRC

This document was prepared primarily for preliminary or internal use. It has not received full review and approval. Since there may be substantive changes, this document should not be considered final.

EG&G Idaho, Inc.  
Idaho Falls, Idaho 83401Prepared for the  
U.S. Nuclear Regulatory Commission  
and the U.S. Department of Energy  
Idaho Operations Office  
Under contract No. DE-AC07-76ID01570  
NRC FIN No. A6038**INTERIM REPORT**

## ACKNOWLEDGEMENT

Our hosts were the people of the IRB division of GfK, headed by Dr. U. Müller. He and his people, particularly Dr. J. Reimann and H. John who led the experimental work and E. Wanner and L. Pawlak who operated the facility, anticipated and provided for our technical and personal needs with insight, alacrity, and graciousness.

The EG&G test operations crew for the Semiscale testing was headed by R. Meininger and consisted of V. Hansen, H. Helbert and L. Lindsay. G. Maki and J. Gilbert produced the entire software package. All these people successfully completed their work on time, and this fact serves well to remind us that the seemingly impossible can be done when determination and expertise are applied. As the complexity of the experimental work becomes more apparent, the reader will better appreciate the magnitude of their accomplishment. Special appreciation is expressed to Russ Tetley of the Information Division, Publications Branch, for the editing of this data report.

## ABSTRACT

Steady state, steam-water testing of a Semiscale Mod-3 system instrumented spool piece was accomplished in the Gesellschaft fur Kernforschung (GfK) facility at Karlsruhe Kernforschungszentrum, W. Germany. The testing was undertaken to determine the accuracy of spool piece, two-phase mass flow rate, inferential measurements by comparison with upstream single-phase reference measurements. Other two-phase measurements were also made to aid in understanding the flow conditions and to implement data reduction. A total of 132 single- and two-phase test points were acquired, covering pressures from 0.4 to 7.5 MPa, flow rates from 0.5 to 4.9 kg/s, and two-phase mixture qualities from 1.0 to 83% in the 66.7 mm inside diameter spool piece. The report includes a detailed description of the hardware and software and a tabulation of the data.

## NOMENCLATURE

- $C_w$  - superficial water velocity, based on  $\dot{m}$ ,  $X$ ,  $P_{TS}$ ,  $T_{TS}$
- $C_s$  - superficial steam velocity, based on  $\dot{m}$ ,  $X$ ,  $P_{TS}$ ,  $T_{TS}$
- DP1 - lower range steam orifice differential pressure
- DP2 - lower range water orifice differential pressure
- DP3 - drag screen (disk) pressure drop
- DP4 - turbine meter pressure drop
- DP5 - sum of drag device, turbine meter pressure drop
- DP6 - upstream frictional pressure drop
- DP7 - sum of frictional, drag device, turbine meter pressure drops
- DP10 - fixed impedance probe pressure drop
- DP11 - higher range steam orifice differential pressure
- DP12 - higher range water orifice differential pressure
- $H_s$  - superheated steam enthalpy from P1, T1
- $H_s$  - subcooled water enthalpy from T2
- $\dot{m}$  - sum of steam and water mass flow rates to the mixer
- $\dot{m}_s$  - steam mass flow rate from DP1 (DP11),  $V_s$ , P1, T1
- $\dot{m}_w$  - water mass flow rate from DP2 (DP12),  $V_w$ , T2
- $P_{TS}$  - absolute fluid pressure upstream of the Semiscale spool piece
- $P_{SP}$  - absolute fluid pressure at spool piece (listed as P4 in Table A-III)
- $\rho_u, \rho_L$  - spool piece chordal average fluid density - upper and lower beam of dual beam densitometer
- $\rho_u^2$  - spool piece momentum flux-drag disk or full flow drag screen as noted
- $\bar{\rho}$  - cross sectional average fluid density - scanning densitometer

### NOMENCLATURE (continued)

- P1 - absolute steam pressure at steam flow orifice
- P3 - absolute fluid pressure at scanning densitometer
- P4 - absolute fluid pressure at Semiscale spool piece
- P5 - absolute fluid pressure just downstream of spool piece
- T1 - temperature at steam flow orifice
- T2 - temperature at water flow orifice
- T3 - fluid temperature at scanning densitometer
- T4 - fluid temperature at Semiscale spool piece
- T6 - metal temperature at Semiscale spool piece
- T9 - fluid temperature just downstream of spool piece
- T<sub>TS</sub> - fluid temperature upstream of the Semiscale spool piece
- T<sub>SP</sub> - fluid temperature at spool piece (listed as T4 in Table A-III)
- T<sub>s4</sub> - saturation temperature in spool piece from P4
- U<sub>w</sub> - radiotracer liquid phase velocity
- U<sub>s</sub> - radiotracer vapor phase velocity
- V<sub>s</sub> - superheated steam specific volume from P1, T1
- V<sub>w</sub> - subcooled water specific volume from T2
- V<sub>s4</sub> - specific volume of saturated steam in spool piece from P4
- V<sub>w4</sub> - specific volume of saturated water in spool piece from P4

## TABLE OF CONTENTS

ACKNOWLEDGEMENT-----	ii
ABSTRACT-----	iii
NOMENCLATURE-----	iv
I. INTRODUCTION-----	1
II. FACILITY, TEST HARDWARE AND OPERATIONS-----	1
1. GfK Two-Phase Flow Facility-----	1
2. Test Section-----	3
3. Test Operation-----	13
III. INSTRUMENTATION AND DATA ACQUISITION-----	16
1. General Description-----	16
1.1 Common Components-----	24
1.1.1 Signal Conditioners and Amplifiers-----	24
1.1.2 Digital Systems-----	24
1.1.3 Analog Recording System-----	25
1.2 Software-----	25
1.2.1 Data Acquisition Function-----	25
1.2.2 Data Validation Function-----	26
1.2.3 Other Functions and Routines-----	28
2. Principal Measurements-----	29
2.1 Single Phase Flow Measurements-----	29
2.2 Semiscale Spool Piece Measurements-----	35
2.2.1 Turbine Meter-----	35
2.2.2 Dual Beam Densitometer-----	37
2.2.3 Momentum Flux Measurement-----	40
2.2.4 Spool Piece Absolute Pressure-----	44
2.3 Other Principal Measurements-----	45

3. Auxiliary Measurements-----	51
3.1 Pressure, Temperature, Differential Pressure-----	51
3.2 Storz Lens-----	53
IV. TEST MATRIX-----	53
V. SUMMARY OF TEST CONDITIONS AND RESULTS-----	56
VI. REFERENCES-----	57
APPENDIX A TABLES OF TEST CONDITIONS, PARAMETERS, AND MEASURED DATA ABSTRACTED FROM REFERENCE 3-----	59
APPENDIX B DATA REDUCTION EQUATIONS-----	95
APPENDIX C DATA VALIDATION ROUTINES-----	107

FIGURES

1. Schematic flow diagram, GfK facility-----	2
2. Facility air-water, and steam-water flow capabilities-----	4
3. Superficial vapor, liquid velocity envelope-----	5
4. Test section arrangement, Semiscale tests-----	6
5. LIT radiotracer injection ports and detectors-----	7
6. GfK impedance probe and electronics-----	8
7. Scanning densitometer installation-----	9
8. Storz lens installation-----	10
9. Semiscale instrumented spool piece-----	11
10. Semiscale spool piece installation-----	12
11. Instrumentation setup sheet-----	14
12. Operating log sheet-----	17
13. Principal data log sheet-----	19
14. Instrument block diagram, Semiscale tests-----	21
15. EG&G Idaho, Inc., computer processed test section transducers-----	22

16. Single-phase IRB transducer setup-----	23
17. Data acquisition printout-----	30
18. Drag screen momentum flux calibration-----	42
19. Densitometer source, pipe, detector geometry-----	46
20. Scanning densitometer block diagram-----	49

TABLES

I. GfK Sensor Check Comparisons of Measured Signals at 20%, 50%, and 100% of Full Scale-----	31
II. Single Phase Spool Measurement Constants-----	34
III. Turbine Meter Calibration Information-----	36
IV. Dual Beam Densitometer Information-----	39
V. Momentum Flux Calibration Information-----	43
VI. Pressure, Temperature Calibration Information-----	52
VII. Equivalent Frictional Resistance K-Factor-----	54
VIII. Test Matrix as Performed-----	55
A-I. Test Conditions as Measured by Institut fur Reaktor Bauelement-----	65
A-II. Principal Measurements-----	70
A-III. Pressure and Temperature Data-----	76
A-IV. Differential Pressure Data-----	82
A-V. Miscellaneous On-Line-Calculated Parameters-----	88

## I. INTRODUCTION

This report presents the experimental data from the steady state, steam-water testing of an instrumented spool piece (pipe) used in the Semiscale Mod-3 test system at the Idaho National Engineering Laboratory. The testing was done in the Gesellschaft für Kernforschung (GfK) facility at Karlsruhe, West Germany. The Semiscale part of the joint EG&G Idaho, Inc., and GfK Test Program was conducted during November-December 1977. Engineers from EG&G Idaho, Inc., Instrumentation Division and two GfK divisions, the Reactor Components Institute (IRB) and the Technical Isotopes Laboratory (LIT), collaborated in performing the experiments.

The principal objective of these tests was to evaluate the capability of the three main spool piece instruments (the dual beam densitometer, full flow turbine, and drag screen) to measure steady state flow rates over the range of conditions experienced in the Semiscale Mod-3 test system. The purpose was to compare the total mass flow rate calculated from these three measurements with the sum of two single-phase measurements and quantify the dependence of the difference. The report contains only the experimental data and on-line-calculated single-phase parameters; two-phase flow modeling calculations and data analysis will be contained in a subsequent report.

The GfK flow facility, test hardware, and typical test operation is described in Section II. Section III describes the instrumentation and data acquisition, including the processing hardware (signal conditioners, amplifiers, digital systems, and analog recording system), computer programs, and principal and auxiliary measurements. The test matrix is presented in Section IV, which delineates the test pressures and associated superficial water and steam velocities. Section V presents a summary of test conditions and results. References are listed in Section VI.

## II. FACILITY, TEST HARDWARE AND OPERATIONS

### 1. GfK TWO-PHASE FLOW FACILITY

The GfK two-phase flow facility is described in detail in References 1 and 2. A simplified schematic flow diagram of the loop used for this spool piece experiment, is shown in Figure 1. Superheated steam from one boiler and subcooled water from the other boiler are directed to the mixer via separate, calibrated, single-phase flow measuring stations. The mixed flow passes through the test section and an outlet pressure control valve to the condenser. Condensate is returned to the boilers via a feed tank and pumps.

Block valves at the mixer and test section outlet (shown in Figure 1), permit the two-phase mixture to be directed either to, or around, the test section. Also shown is the dump tank used to collect the total mixture flow during radiotracer injections.

T Temperature  
 P Pressure  
 ΔP Differential pressure

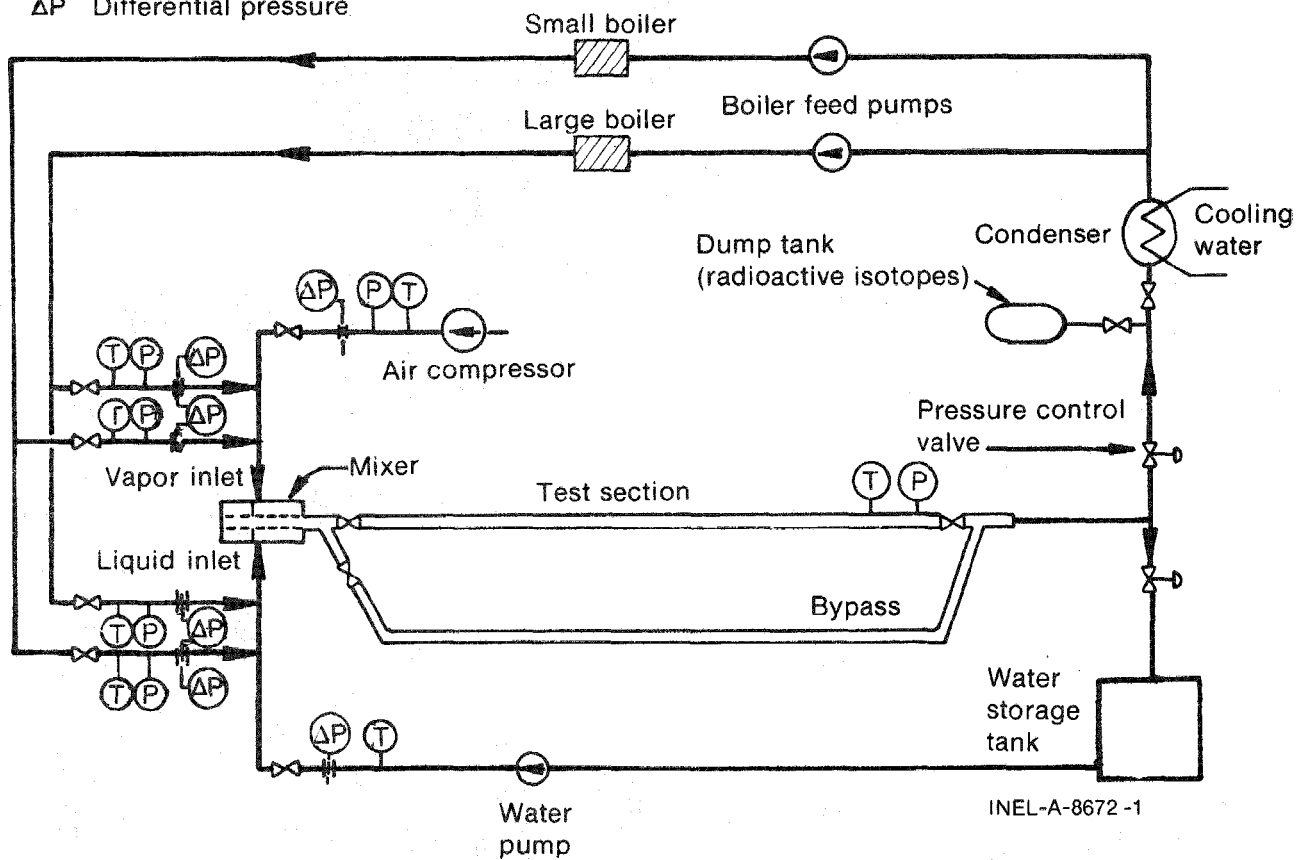

INEL-A-8672 -1

Figure 1. Schematic Flow Diagram, GfK Facility.

For air-water testing, a compressor and separate water pump supply fluids to the mixer. The air-water mixture is separated in the water storage tank.

Figure 2 shows the flow rates which can be provided at different vapor mass fractions for air-water and steam-water operation. Normal air-water operation was at 0.4 MPa or below, while the steam-water flow rates generally apply from 0.4 to 10.0 MPa. Figure 3 provides the same information for various pressures in terms of superficial water and vapor velocities in a 50 mm inside diameter test section.

## 2. TEST SECTION

The test section consisted of an 8-m length of piping with inlet and outlet block valves on either end, as shown in Figure 4. The 3-in. Schedule 160, Type 304 stainless steel piping (nominal 66.7 mm inside diameter, 88.9 mm outside diameter) provided by EG&G Idaho, Inc., constituted the first 6.5 m and the 50-mm inside diameter piping, provided by GfK made up the remaining 1.5 m. Eccentric reducers were used to connect the different size pipes and to maintain the bottom of the piping at the same elevation. Each spool had two rolling, vertically adjustable supports which were mounted on the test bed, and each spool was carefully leveled. Connections between spools in the 3-in. stainless steel piping were made with Grayloc fittings, while the 50 mm piping used standard GfK flanges.

The 1.36-m inlet block valve spool had a 50-mm inside diameter for Test Runs 2201 through 2247 which resulted in the flow expanding from 50 to 66.7-mm at the beginning of the test section. For Test Runs 2249 through 2340, the 50-mm spool was replaced with an 80-mm inside diameter spool so that the flow entering the test section contracted from 80-mm to 66.7-mm. The Semiscale spool piece was located about 65 diameters downstream from the expansion/contraction point.

The LIT radiotracer injection ports were located in the first 3-in. spool piece (designated S1) with detectors mounted at various distances throughout the 6.5-m length downstream of these ports. Figure 5 shows the ports and first few detectors. Two fixed-position impedance probes were located at the same axial point in spool piece S2: one entering the flow from the top side of the pipe, the other from the bottom side. Figure 6 shows the associated electronics and upper impedance probe. The scanning densitometer (Figure 7) was mounted in spool piece RD1, at a point about 23 cm upstream from the inlet of the Semiscale spool. When used, the Storz lens was mounted in the downstream flange at the scanning densitometer, as shown in Figure 8. The Mod-3 Semiscale spool piece and instrumentation are shown in Figure 9. Figure 10 shows the maze of pressure sense lines, cooling water and control air tubing and signal cables associated with the installed spool piece instrumentation. Detailed descriptions of the radiotracer and impedance probe measurements are given in Reference 3. The scanning densitometer, Storz lens, and Semiscale instruments are discussed in detail in Sections 2.3 and 3.2.

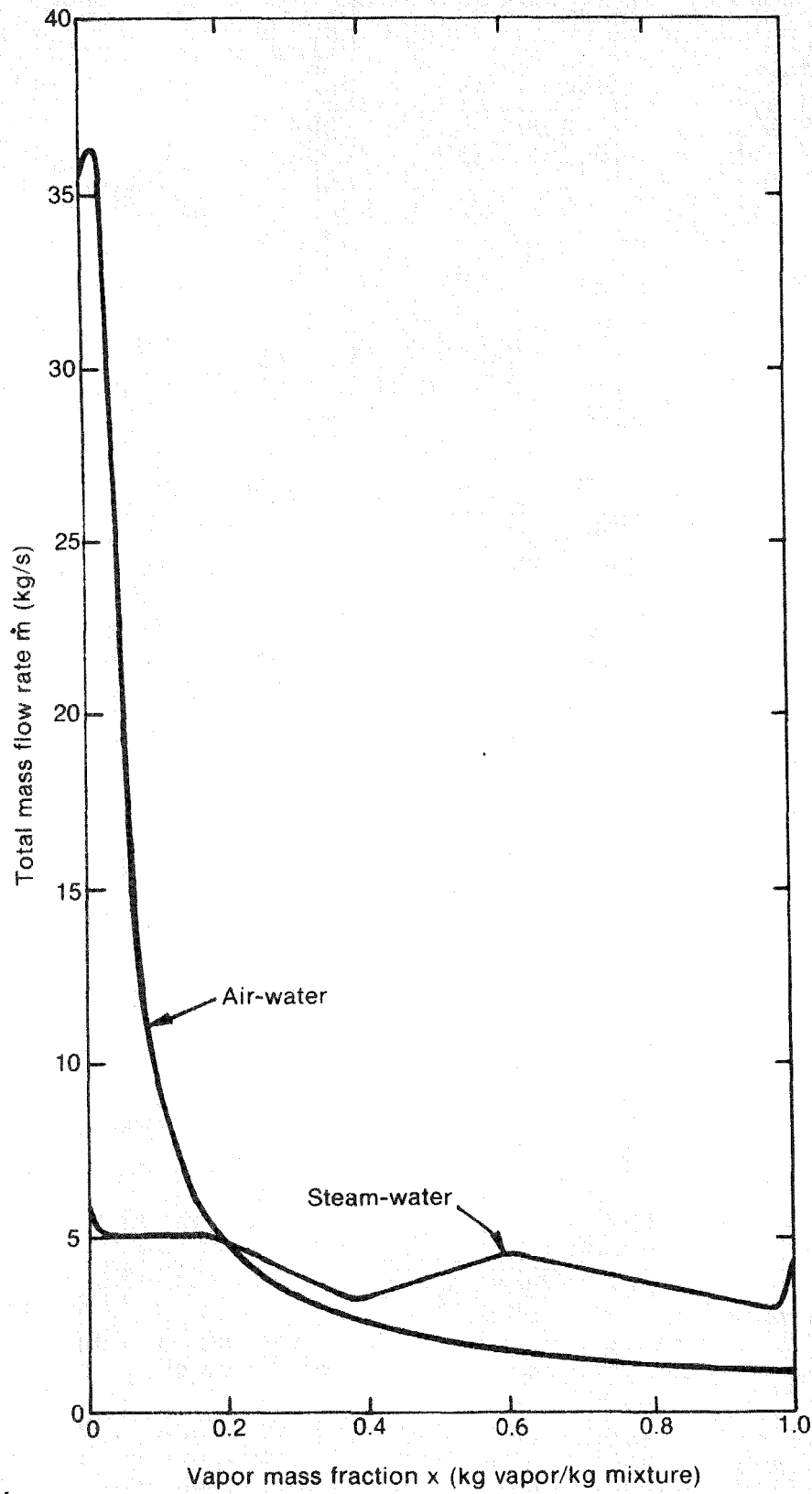

INEL-A-8676

Figure 2. Facility Air-Water, Steam-Water Flow Capabilities.

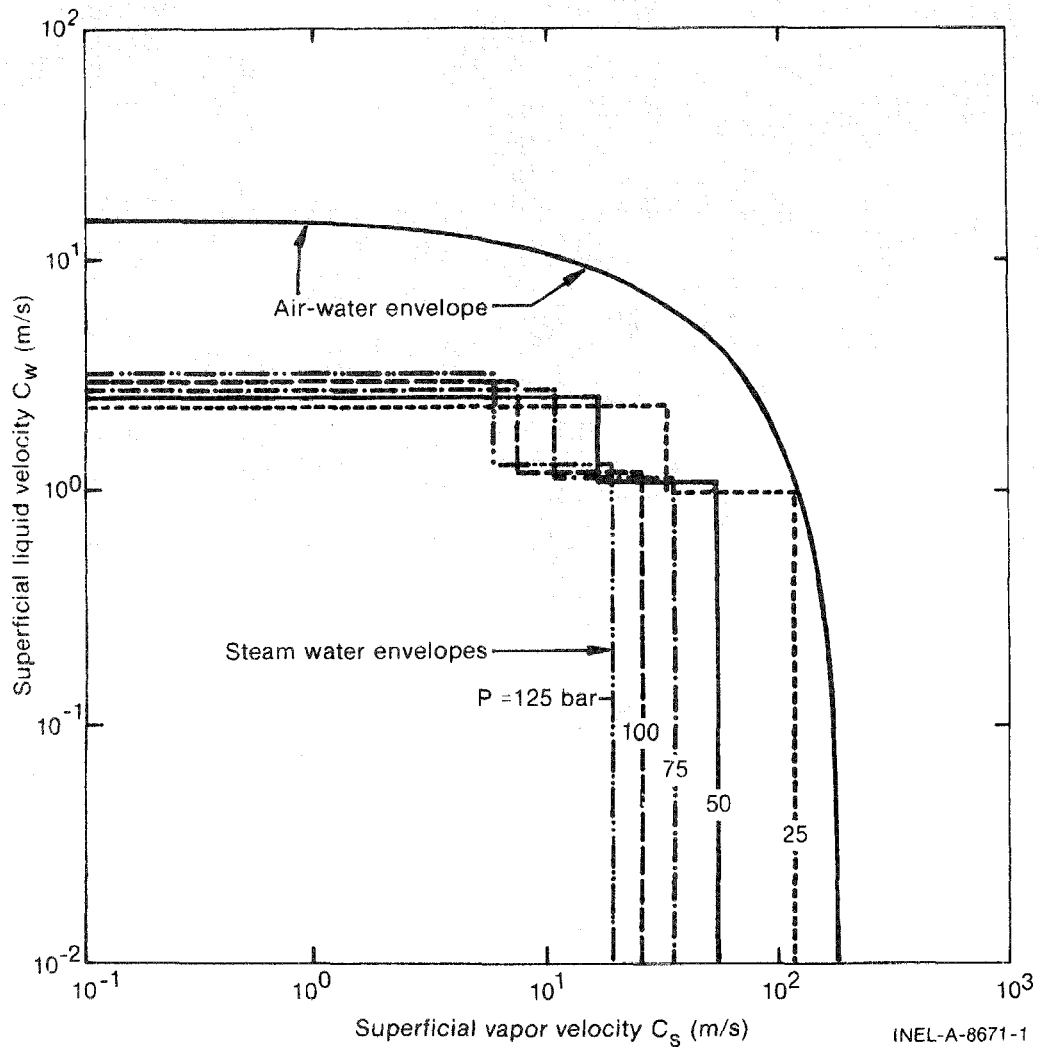

Figure 3. Superficial Vapor, Liquid Velocity Envelope.

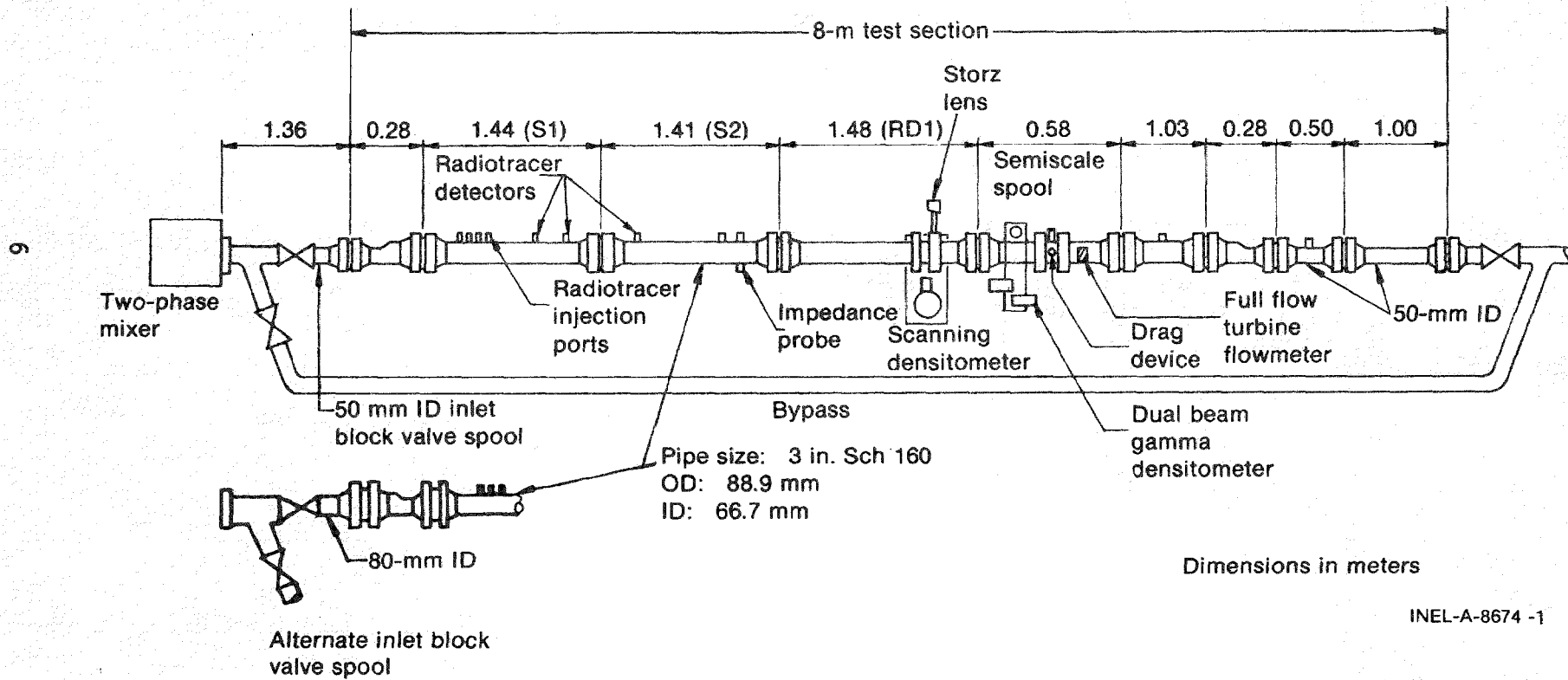

Figure 4. Test Section Arrangement, Semiscale Tests.

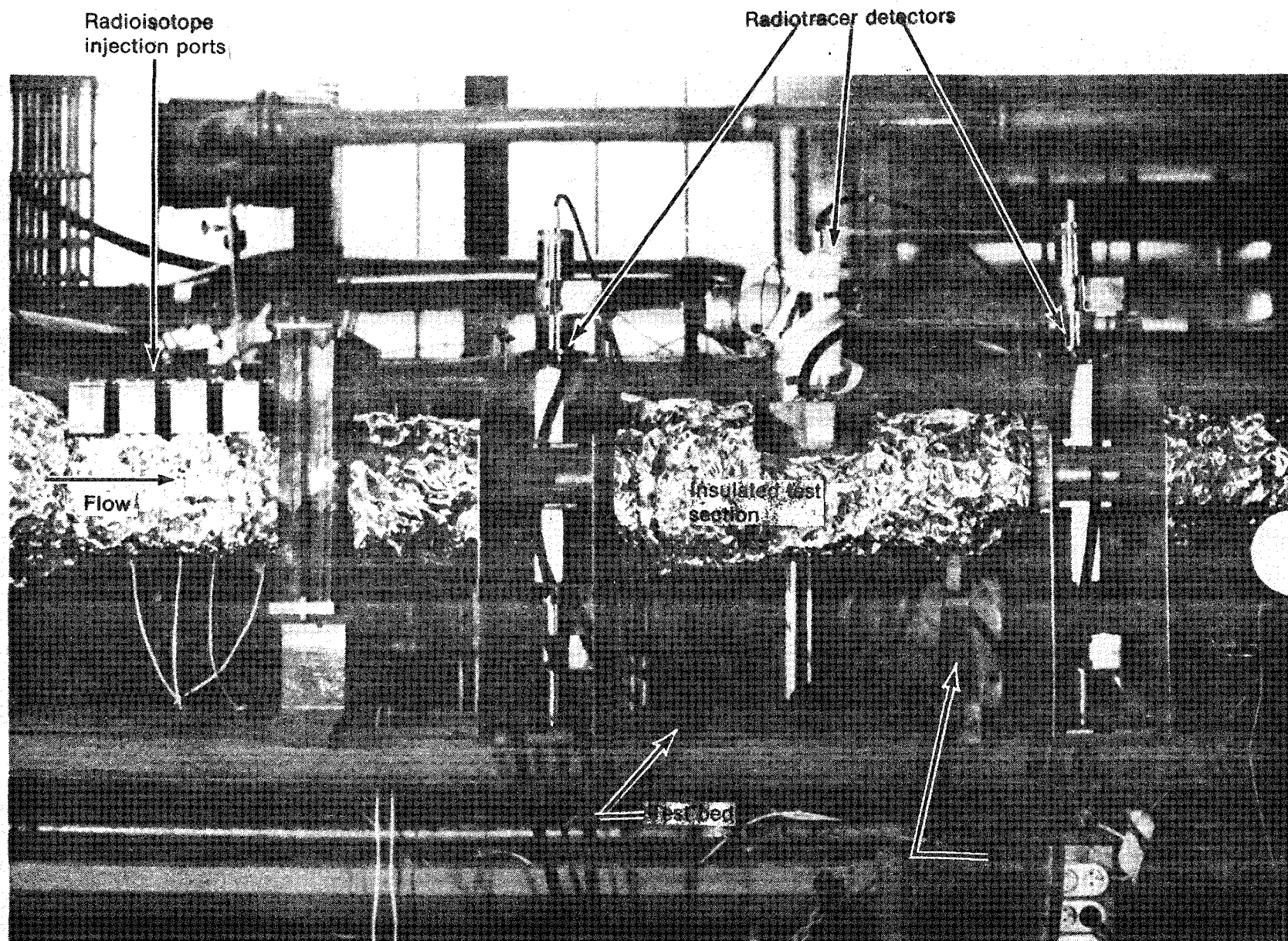

Figure 5. LIT Radiotracer Injection Ports and Detectors.

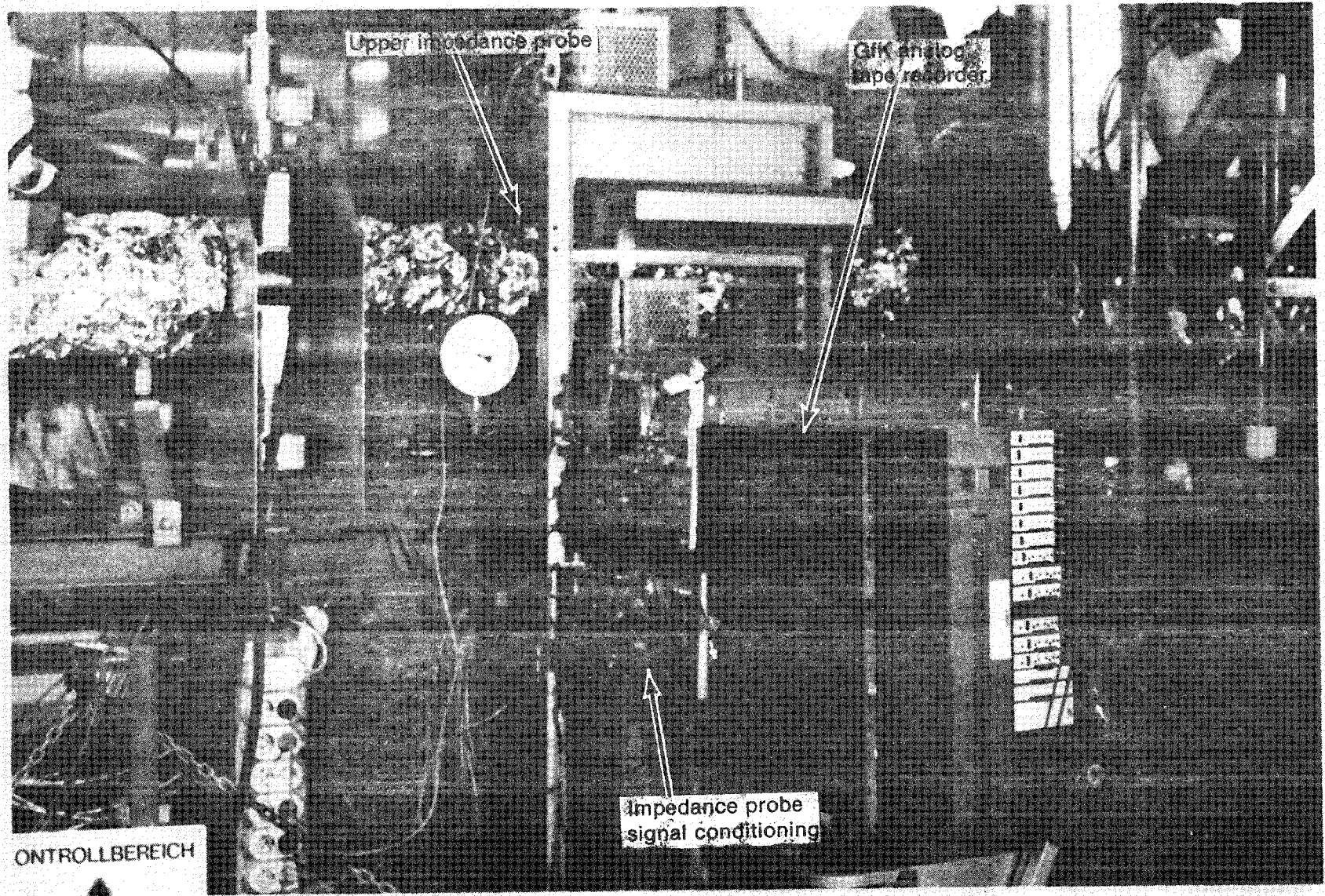

Figure 6. GFK Impedance Probe and Electronics.

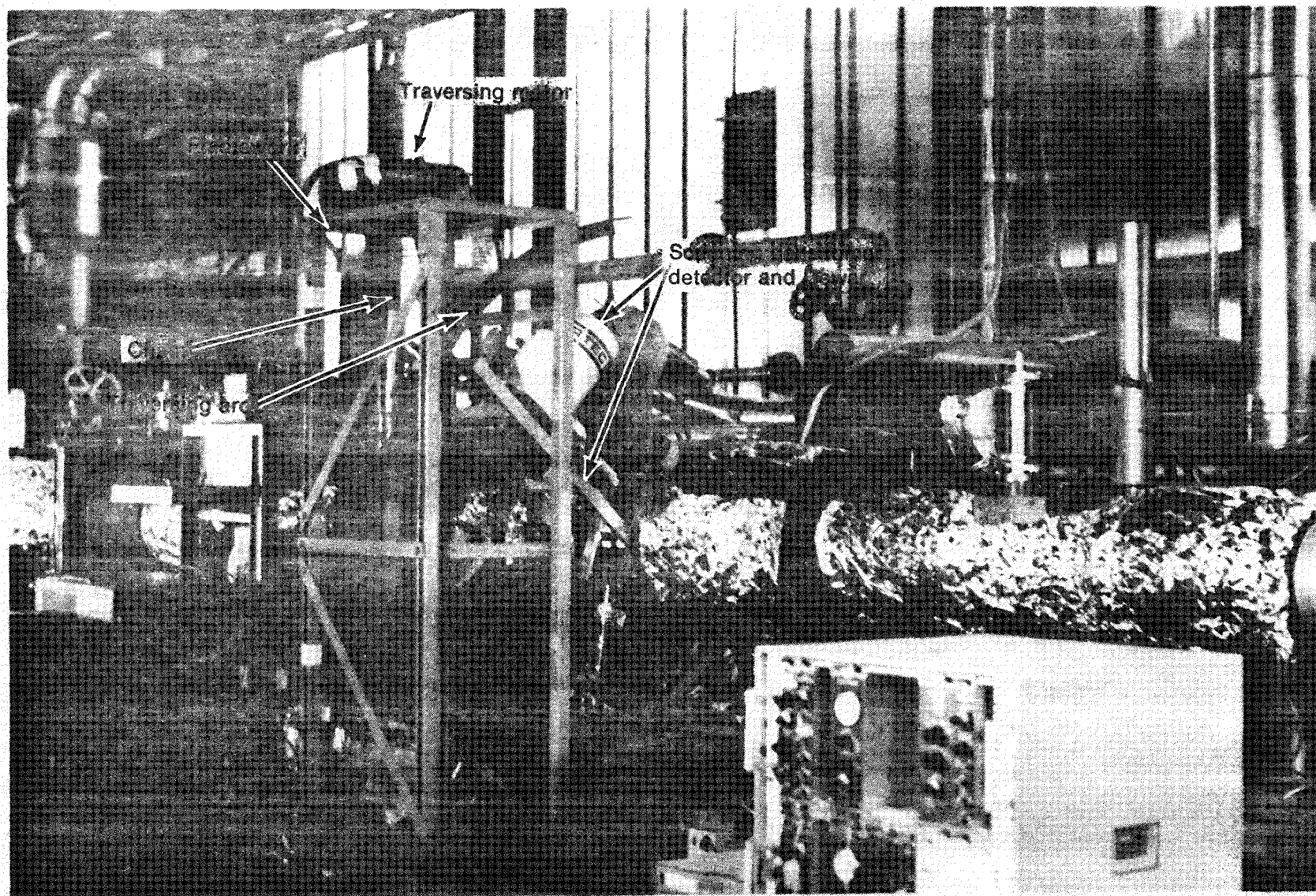

Figure 7. Scanning Densitometer Installation.

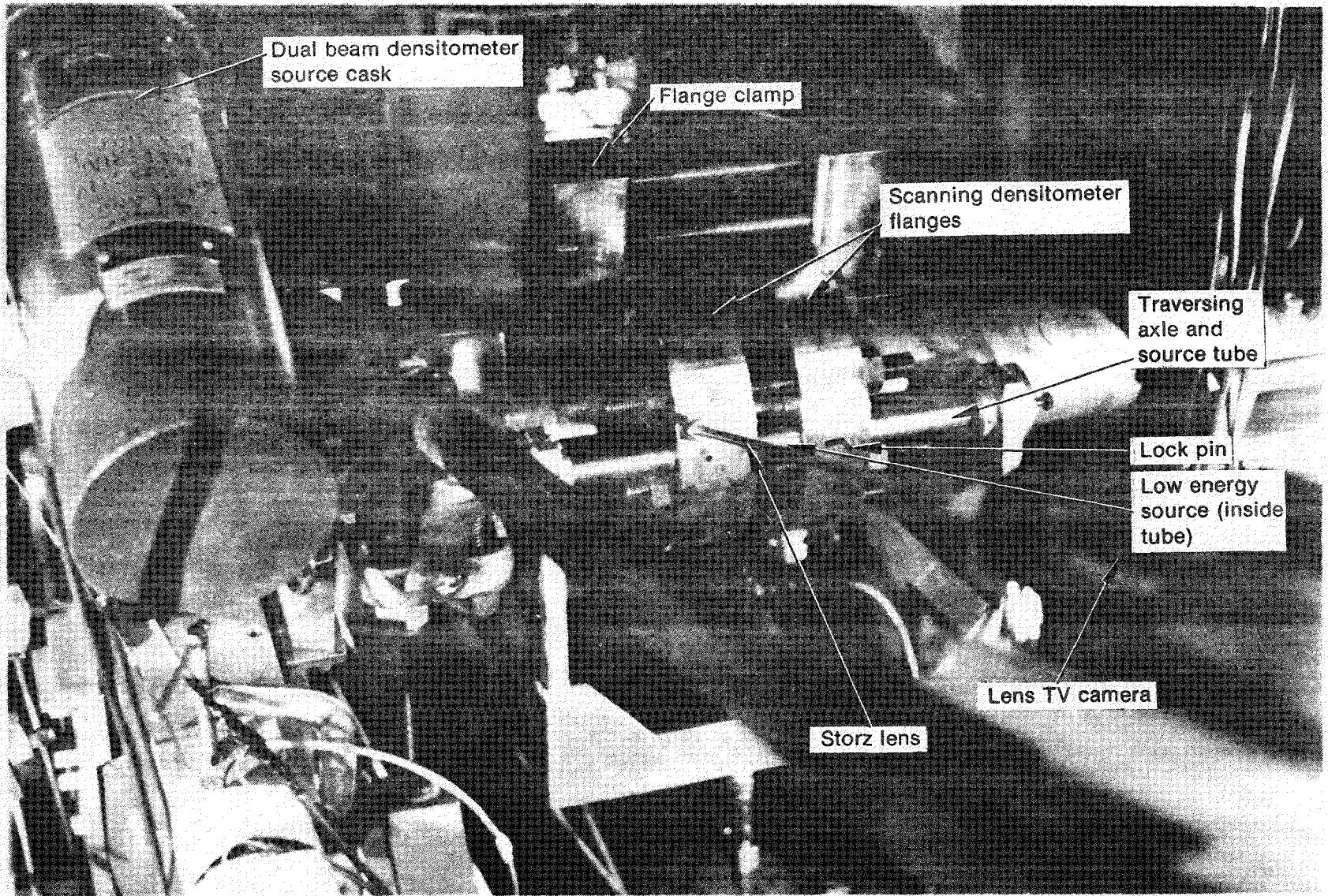
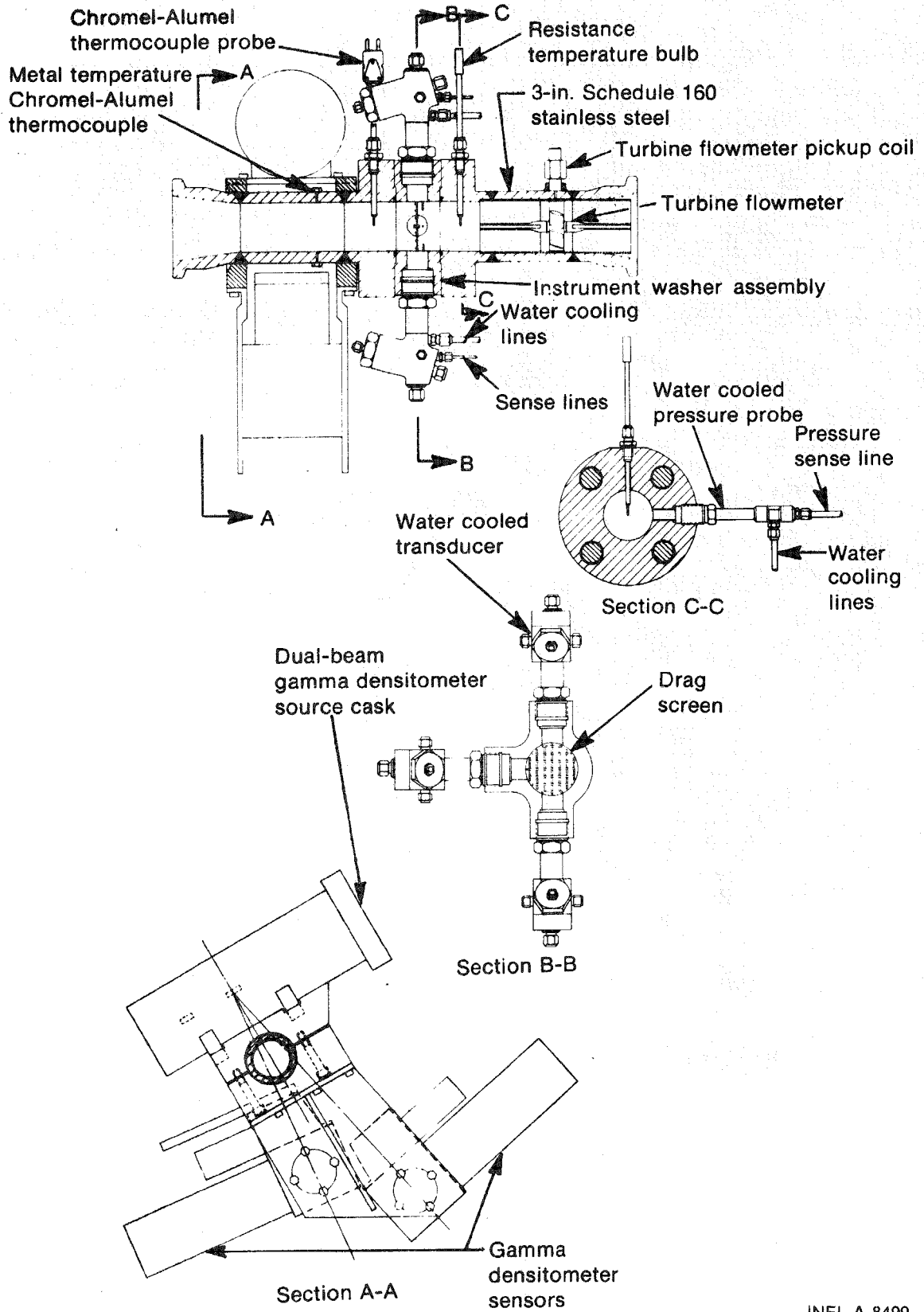

Figure 8. Storz Lens Installation.



INEL-A-8499

Figure 9. Semiscale Instrumented Spool Piece.

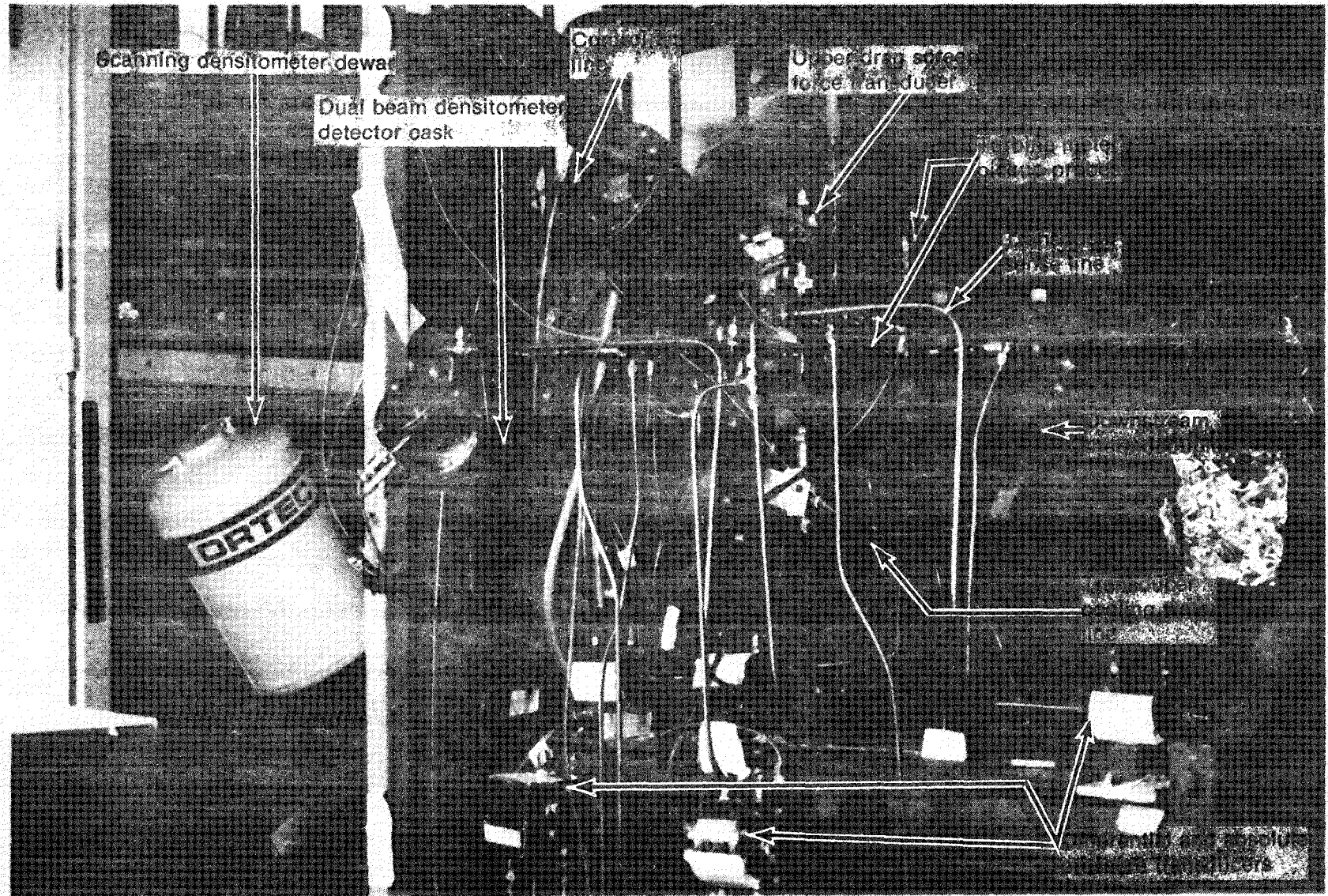

Figure 10. Semiscale Spool Piece Installation.

### 3. TEST OPERATION

The daily testing consisted of the following regimen:

1. Establish the revised test run conditions for the day.
2. From these conditions, choose which boiler would provide steam, and which would provide water, and set up valving and steam and water measurement channels. Figure 11 is a copy of a typical instrumentation setup sheet, filled out each time a change was made in the hardware condition.
3. Set an all water point to check instruments.
4. Start boiler and system heatup.
5. Start two-phase flow tests.
6. At the end of the day, shutdown, set an all water point to check instruments.

For the two-phase testing, three parameters defined a matrix point: test section pressure, superficial water velocity at the test section, and superficial steam velocity. The boiler operator used the measurement of the superheated steam flow to the mixer, the subcooled water flow to the mixer, the test section pressure, and an energy balance to establish the total mass flow and quality at the test section. From these data, the superficial steam and water flows at the test section were computed. The computation was done on the facility PDP-11 computer, controlled through a teletype at the boiler control room. The required results are tabulated in Appendix A, Table A-I, Test Conditions as Measured by Institut für Reaktor Bauelement. Ordinarily, 20 to 30 minutes were required to establish a new steady condition.

Once a steady condition had been established, the experimental data were acquired as follows:

1. The impedance probe data were recorded on the GfK analog magnetic tape.
2. The scanning densitometer was started through its traverse around the pipe.
3. The EG&G Idaho, Inc., data acquisition computer (HP-21MXE) was set to acquire time-averaged values of the several test parameters.
4. The EG&G Idaho, Inc., analog magnetic tape recorders were turned on and after one minute were turned off.
5. When the computer had acquired, processed, and printed the time-averaged values, an initial quick glance at this data was performed by the computer operator.

Semiscale STEAM-WATER

SENSOR			CHANNEL				BL	HP Coefficients				Comments	IRIG A on Tape Channel 1-12, 2-14	
ID	Make	SN	BL	TR	SC	HP	Gain	a <sub>0</sub>	a <sub>1</sub>	a <sub>2</sub>	a <sub>3</sub>			
P	H	53 TM11	1	1-1	1	1	2	10.43	299.06				STEAM - NW 65	
<del>X</del>	<del>B</del>	<del>37 TM9</del>	<del>1</del>	<del>1-1</del>	<del>1</del>	<del>1</del>	<del>2</del>	<del>10.43</del>	<del>299.06</del>				<del>STEAM - NW 30</del>	
P3	CEC	100 2413	3	2-1	-	3	1000	12.696	59.656					
P4	VIA	100 344 775	4	2-2	-	4	1000	2.248	8.4799				10mv @ 450 p.	
P5	CEC	100 2611	5	2-3	-	5	1000	12.775	63.008					
D11	H	53 TM6	6	1-2	2	6	2	0	.45313				STEAM HI - NW 65	
D1	H	54 TM7	7	1-6	3	7	2	0	.05664				STEAM LO - NW 65	
<del>X</del>	<del>B</del>	<del>51 TM2</del>	<del>6</del>	<del>1-2</del>	<del>2</del>	<del>6</del>	<del>2</del>	<del>0</del>	<del>.45313</del>				<del>STEAM HI - NW 100</del>	
<del>X</del>	<del>B</del>	<del>58 TM3</del>	<del>7</del>	<del>1-6</del>	<del>3</del>	<del>7</del>	<del>2</del>	<del>0</del>	<del>.05664</del>				<del>STEAM LO - NW 100</del>	
D3	BLH	SC 42702	8	1-3	7	8	1000	-0.00498	.1214					
D4	BLH	SC 71471	9	2-4	-	9	1000	-0.00092	.2422					
D5	BLH	SC 77932	10	2-5	-	10	1000	-0.013	1.485					
<del>X</del>	<del>H</del>	<del>16 TM4</del>	<del>11</del>	<del>1-4</del>	<del>4</del>	<del>11</del>	<del>2</del>	<del>0</del>	<del>.45313</del>				<del>WATER HI - NW 32</del>	
<del>X</del>	<del>H</del>	<del>17 TM5</del>	<del>12</del>	<del>1-4</del>	<del>5</del>	<del>12</del>	<del>2</del>	<del>0</del>	<del>.05664</del>				<del>WATER LO - NW 32</del>	
D2	B	50 TM1	12	1-4	5	12	2	0	.45313				WATER - NW 50	
<del>X</del>	<del>H</del>	<del>17 TM4</del>	<del>6</del>	<del>1-2</del>	<del>2</del>	<del>6</del>	<del>2</del>	<del>0</del>	<del>.45313</del>				<del>THROTTLE HI - NW 32</del>	
<del>X</del>	<del>H</del>	<del>17 TM5</del>	<del>7</del>	<del>1-6</del>	<del>3</del>	<del>7</del>	<del>2</del>	<del>0</del>	<del>.05664</del>				<del>THROTTLE LO - NW 32</del>	
<del>X</del>	<del>B</del>	<del>17 TM1</del>	<del>7</del>	<del>1-6</del>	<del>3</del>	<del>7</del>	<del>2</del>	<del>0</del>	<del>.45313</del>				<del>THROTTLE - NW 50</del>	
D6	BLH	SC 39192	16	1-5	9	16	1000	-0.00136	.07302					
D7	BLH	SC 44296	17	2-6	-	17	1000	-0.069	.7446					
D10	BLH	SC 43544	18	2-7	-	18	1000	-0.0082	.6425					
T6			19	2-8	-	19	1000	150.4	45.28	-0.1573	.00285			
T4			20	2-9	-	20	1000	150.4	45.28	-0.1573	.00285			
T1	H	56 TA9	21	2-10	-	21	500	32	90.36	-0.3197	.00376		STEAM - NW 65	
<del>X</del>	<del>B</del>	<del>60 TA2</del>	<del>21</del>	<del>2-10</del>	<del>-</del>	<del>21</del>	<del>500</del>	<del>32</del>	<del>90.36</del>	<del>-0.3197</del>	<del>.00376</del>		<del>STEAM - NW 30</del>	
<del>X</del>	<del>H</del>	<del>49 TA3</del>	<del>22</del>	<del>2-11</del>	<del>-</del>	<del>22</del>	<del>500</del>	<del>32</del>	<del>90.36</del>	<del>-0.3197</del>	<del>.00376</del>		<del>WATER - NW 32</del>	
T2	B	52 TA1	22	2-11	-	22	500	32	90.36	-0.3197	.00376		WATER - NW 50	
<del>X</del>	<del>H</del>	<del>49 TA3</del>	<del>21</del>	<del>2-10</del>	<del>-</del>	<del>21</del>	<del>500</del>	<del>32</del>	<del>90.36</del>	<del>-0.3197</del>	<del>.00376</del>		<del>THROTTLE - NW 32</del>	
<del>X</del>	<del>B</del>	<del>52 TA1</del>	<del>21</del>	<del>2-10</del>	<del>-</del>	<del>21</del>	<del>500</del>	<del>32</del>	<del>90.36</del>	<del>-0.3197</del>	<del>.00376</del>		<del>THROTTLE - NW 50</del>	
T3			23	2-12	-	23	1000	150.4	45.28	-0.1573	.00285			
T9			25	2-13	-	25	1000	150.4	45.28	-0.1573	.00285			
R1			26	1-8	13	26	1	206.24	9.986	.005			a <sub>1</sub> = 10.24 after run 2292	
R2			27	1-9	14	27	1	120.66	9.953	.005			a <sub>1</sub> = 10.24 after run 2292	
EFK R1			28	-	-	28	10v							
EFK R2			29	-	-	29	10v							
G1			31	1-10	15	31	2	0	.4				Range 3	
<del>X</del>			<del>32</del>			<del>32</del>	<del>1000</del>							<del>X</del>
F1			33	1-11	16	33	5	8671.4	2270				Bottom	
F3			34	1-13	17	34	5	+6072.3	2270				Side	
F2			14	1-14	18	14	5	3007.8	2270				Top	

Figure 11. Instrumentation Setup Sheet (Sheet 1 of 2).

FIGURE 11 INSTRUMENTATION LOG SHEET  
(Sheet 2 of 2, explanation of log sheet headings)

Sensor ID (Identification) column is the designation used in the EG&G Idaho, Inc., computer and in the data tables in this report. Transducer manufacturer is given if transducer is provided by EG&G Idaho, Inc., or IRB boiler designation is given (H-Henschel (small) boiler; B-Benson (large) boiler for GfK equipment).

Sensor (SN) column gives transducer serial number for EG&G Idaho, Inc., equipment or transmitter number (also GfK computer channel number) for GfK equipment (refer to Figure 16).

Channel designations are; BL - Bay Laboratories Amplifier Number; TR-Analog Magnetic tape recorder number and channel on that recorder; SC - Brush Recorder Channel Number; HP - computer (ADC) channel number.

BL Gain - Bay Laboratories amplifier gain setting

HP Coefficients - coefficients of the equation relating measured voltage to engineering units

"NW 65/NW 50" - Refer to Figure 16. These are designations of GfK calibrated single-phase measurements spools and identify the source of the steam and of the water for that day. That is, NW 65/NW 50 implies steam is supplied by the small boiler, water by the large boiler. The lines crossed out represent instrument channels not used as a result of using the NW 65/NW 50 CHOICE.

6. If there were no visual data problems, the LIT personnel were informed that the radiotracer injections could proceed and the test hall was evacuated. Radiotracers were not available every day.
7. The radiotracer measurement was made and test personnel returned to their stations.
8. The scanning densitometer traverse was completed and the boiler operator was informed that he could proceed to the next point.
9. The operating log sheet was completed for the run. A copy of a typical sheet is shown in Figure 12.
10. Principal data from the boiler operator, EG&G Idaho, Inc., computer, and the radiotracer (when available) were then collected on the daily summary sheet and reviewed by an analyst. Figure 13 is a copy of such a sheet.

The experiment data acquisition process took about 15 minutes when all went well. Frequently, computer data were taken a second time to verify that the time-averaged values were the same over these 15 minutes. It was a very unusual occurrence to find that they were significantly different.

### III. INSTRUMENTATION AND DATA ACQUISITION

#### 1. GENERAL DESCRIPTION

Figure 14 is an instrument block diagram showing all of the test instrumentation involved in the Semiscale tests. IRB engineers were responsible for the single-phase measurements (superheated steam and subcooled water going to the mixer) and the impedance probes. EG&G Idaho, Inc., personnel monitored their test section transducers and the scanning densitometer. LIT operators monitored their radiotracer measurements. The description which follows is restricted to only the EG&G Idaho, Inc., equipment and other measurements which were processed through the data acquisition computer.

Figure 15 lists the measurements on the Semiscale and reference (scanning) densitometer spool pieces processed through the EG&G Idaho, Inc., computer. Note that the drag screen, with its three transducers (F1, F2, F3), was used on tests through December 15 (Runs 2201 through 2302), whereas the drag disk (F6) was used thereafter (Runs 2303 through 2340). Also note that in addition to the impedance probe data four measurements were recorded on the IRB analog tape recorder. These are shown in Figure 14 and noted in Figure 15. In addition to the 19 measurements shown in Figure 15, a maximum of 7 more measurements from the IRB single-phase transducers were processed by the EG&G Idaho, Inc., computer. These single-phase measurements are shown in Figure 16. They constituted a backup to the IRB facility computer and also facilitated some of the EG&G Idaho, Inc., data validation calculations.

## OPERATION LOG SHEET

Date 15 Dec 77

TSN	SETUP REF. NO.	IRIG. START	IRIG. END	Turb. Range	Type	Scan Sens	RADIO TRACER DATA	IMP. PROBE DATA	COMMENTS
2284C	<del>36</del> 36	349/07:56.30	57.20	—	4-348	—	—	—	0 25 50 75 100 0
2284	36	<del>12:07:30</del> 12:09.30	12:10.00	3		P (bar) 4.883 11:30 Temp = 18.6°C	11:40 yes 12:15		
2285	36	12:32:30 1	12:34:45	5		No	yes 12:38	200 500 Kingof.	Turbine Signal looks bad Paused at 33:30 No scanning done.
2286	36	12:58:45	13:00:25	2		No	13:01	500 500 Flow probe bubble ⇒ 500	
2287	36	13:14.30	13:15.00	3		yes	13:23	yes	
2288	36	13:33.00	13:34.40	3		yes	13:43	yes	
2289	36	14:01.30	14:02.30	3		yes	14:10	yes	

Figure 12. Operating Log Sheet (Sheet 1 of 2).

1/28

FIGURE 12 OPERATION LOG SHEET  
(Sheet 2 of 2, explanation of log sheet data)

TSN - Experiment Run

Setup Reference Number - instrument setup defined by Figure 11.

IRIG Start/End - time code generator times for recording analog magnetic tape data for associated run.

Turbine Meter Range Position - turbine signal conditioner range implies certain engineering units coefficient (Figure 11).

Tape - assigned serial number for analog magnetic tape recording.

Scan Densitometer - scanning densitometer data taken for that run

Radiotracer Data - time of day radiotracer injection started.

Impedance Probe Data - impedance probe data taken; location on GfK tape.

TEST OF THE SEMISCALE SPOOL PIECE

15.12.77

3" PIPE, STEAM-WATER FLOW, DEC. 77

TIME	TEST NO.	MATRIX	POINTS	MEASURED VALUES IRB										MEASURED VALUES INEL										VALUES LIT				
				P bar	C <sub>w</sub> m/s	C <sub>s</sub> m/s	P <sub>TS</sub> bar	T <sub>15</sub> °C	C <sub>w</sub> m/s	C <sub>s</sub> m/s	m kg/s	x %	Flow Regime	P <sub>3</sub> bar	T <sub>3</sub> °C	m <sub>3</sub> kg/s	Q <sub>1</sub> m <sup>3</sup> /s	RHOBAR kg/m <sup>3</sup>	MOMFLX kg/m <sup>2</sup>	P <sub>113</sub> kg/m	m <sub>10</sub> kg/s	m <sub>10B</sub> kg/s	m <sub>10DB</sub> kg/s	V <sub>w</sub> m/s	V <sub>s</sub> m/s	in kg/s		
1438?																									1.1?	1.5?		
1211?	2294																								1.1?	1.4?		
1233	2285	4	10	C <sub>max</sub>	4.076	143.3	1.025	43.43	3.64	9.2	200.50	3.49	150.1	3.49	91.9	30.96	18091.5							2.8494	2.5744	2.4216	33	40
1301	2286	"	1.0	40	4.399	159.7	1.049	4.137	3.403	1.0	500.900	3.91	153.2	3.47	15.4	290.3	999.3							4.5282	1.8561	0.7866	3	48
1314	2287	"	1.0	10	4.076	146.9	1.025	12.894	3.40	2.9	1100	3.48	150.2	3.46	21.5	143.2	2639.9							3.1602	2.0780	1.6566	38	129
1333	2288	"	1.0	20	4.076	146.9	1.007	20.768	3.403	4.7	1100	3.53	150.5	3.46	19.3	124.7	3483.7							2.4183	2.2705	2.3433	4.0	4.0
1403	2289	"	0.5	40	4.157	146.2	0.504	41.274	1.947	16.6	13-1500	3.62	151.1	1.97	36.4	-3.572	10985.6							-0.1301	0.2187	3.6935	31	100
1423	2290	"	0.5	20	4.399	149.8	0.495	21.202	1.764	9.9	15-1700	3.835	152.8	1.78	10.5	62.4	2005.7							0.6531	1.2150	2.4238	3.2	29
1506	2291	"	0.5	10	3.915	146.9	0.534	11.753	1.808	4.8	12-1100	3.39	149.3	1.83	8.5	109.2	960.6							0.9742	1.0938	1.3557	2.7	2.7
1524	2292	"	0.5	5	4.480	151.7	0.475	3.092	1.550	1.7	19-2100	3.92	153.5	1.57	7.0	187.8	437.5							1.3283	0.9681	0.7523	1.4	1.9
1551	2293	"	0.2	5	4.560	150.9	0.281	4.134	0.938	3.8	21-2650	3.18	147.6	1.20	7.0	200.3	517.6							1.4375	1.0629	0.8576	1.6	7.0
1616	2294	"	0.2	20	4.802	153.5	0.153	18.294	0.654	25.9	24-1600	4.213	155.6	0.657	6.80	108.0	775.3							0.735	1.006	1.389	2.0	2.0
1636	2295	"	0.2	10	4.722	152.0	0.175	9.233	0.449	18.2	2600 2700	3.668	151.6	0.802	6.60	152.0	398.1							1.005	0.8444	0.7340	2.2	1.6
1651	2296	"	0.2	40	4.318	148.7	0.249	42.16	1.047	32.7	2700 2850	3.767	152.2	1.066	18.0	65.83	6809.							1.189	2.330	4.661	28	36
1708	2297	"	0.0	30	4.318	165.1	0	31.65	0.247	104.2	-	3.714	170.5	0.270	9.10	41.15	1021.							0.3752	0.7120	1.382		283
1739	2298	"	0.0	60	4.399	172.4	0	58.99	0.468	104.3	-	3.881	176.9	0.432	136.9	37.61	3338.							5.148	1.231	0.300		56
1803	2299	~4	0.2	MAX	4.722	143.6	0.491	78.753	1.307	53.2	2850 3050	4.085	154.1	1.385	172.7	37.47	26364.							6.472	3.455	1.867		
1823	2300	~4	0.5	MAX	5.448	147.6	0.447	64.957	2.210	29.3	3060 3250	4.796	159.3	2.325	167.4	38.55	35946.							6.453	4.089	2.624		
1835	2301	~4	1.0	MAX	6.013	150.2	1.002	57.492	3.752	15.2	3250 3550	5.376	163.1	3.872	111.3	63.36	26396.							11.23	4.505	1.819		
1855	2302	~4	MAX	0.0	4.349	134.6	1.119	0	3.872	-2.3		3.862	137.0	3.582	0.5	993.2	519.6							0.542	2.504	20.01		

19

Figure 13. Principal Data Log Sheet (Sheet 1 of 2).

FIGURE 13 PRINCIPAL DATA LOG SHEET  
(Sheet 2 of 2, explanation of log sheet headings)

Matrix Points - desired test section pressure, superficial steam and water velocities ( $P$ ,  $C_w$ ,  $C_s$ ).

Measured Values IRB - actual test section pressure, temperature, superficial water and steam velocities, total mass flow, quality and impedance probe data location on tape and inferred void fraction.

Measured Values INEL - actual Semiscale spool piece measured values for turbine meter ( $Q_1$ ), dual beam densitometer (RHOBAR), drag screen momentum flux (MOM FLX); scanning densitometer pressure, temperature and cross sectional average density ( $P_3$ ,  $T_3$ ,  $\rho_{SD}$ ); total mass flow rate calculated from turbine/densitometer, densitometer/drag body, and turbine/drag body ( $\dot{m}_{TD}$ ,  $\dot{m}_{D+DB}$ ,  $\dot{m}_{T+DB}$ ).

Values LIT - radiotracer measured phase velocities ( $v_w$ ,  $v_s$ ).

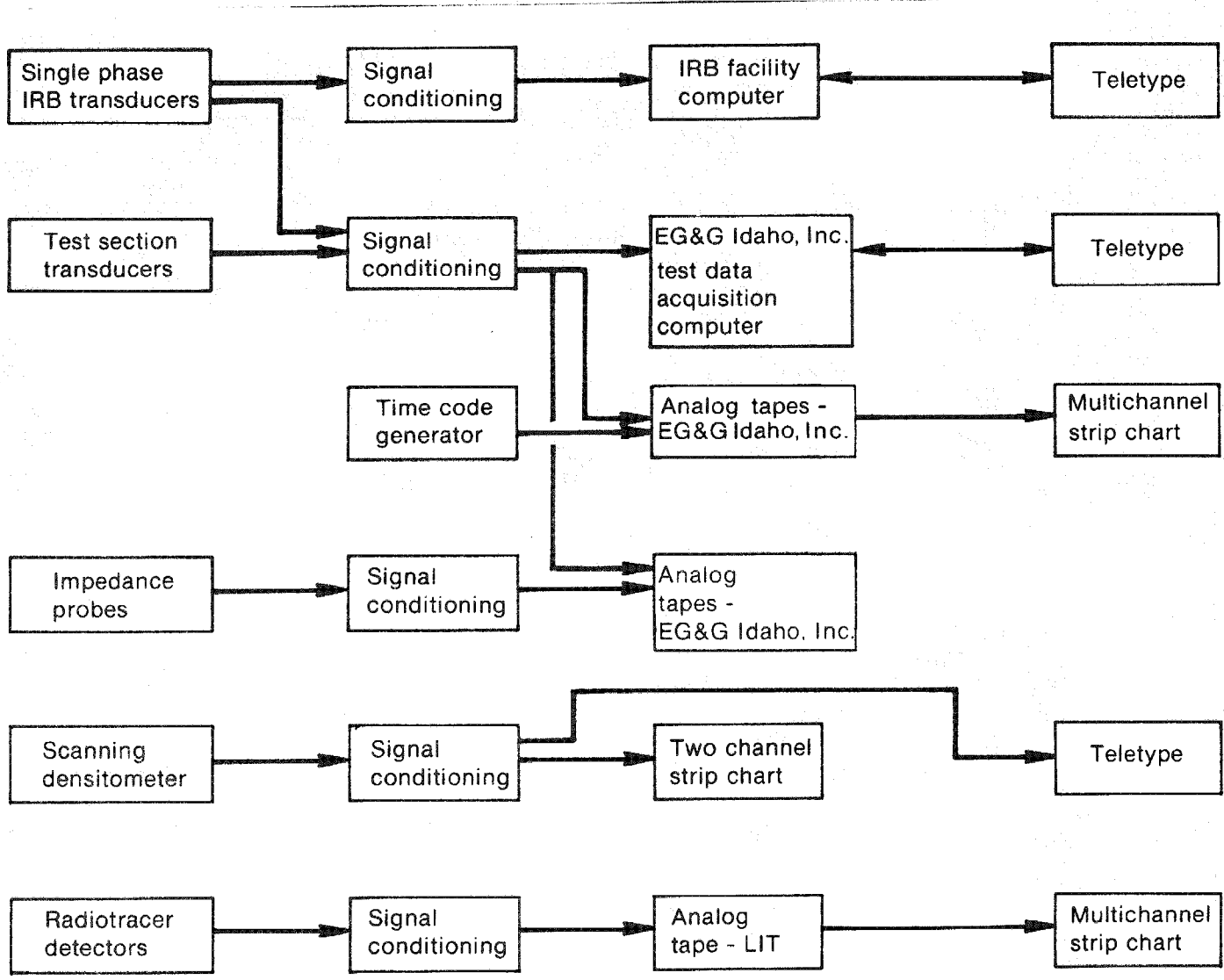

INEL-A-8670

Figure 14. Instrument Block Diagram, Semiscale Tests.

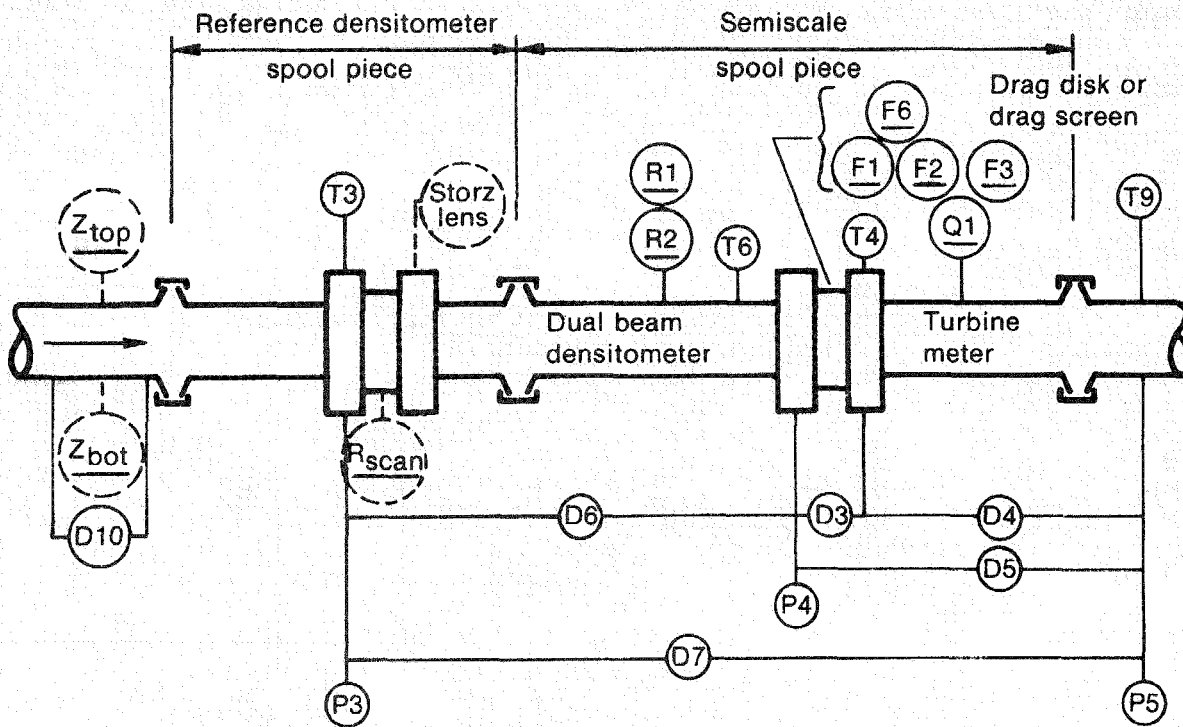

- D3<sup>x,+</sup> - Drag device differential pressure
- D4<sup>+</sup> - Turbine meter differential pressure
- D5 - Drag + turbine differential pressure
- D6<sup>+</sup> - Upstream differential pressure
- D7 - Total differential pressure
- D10<sup>x</sup> - Impedance probe differential pressure
- F1<sup>+</sup> - Force 1 on drag screen
- F2<sup>+</sup> - Force 2 on drag screen
- F3<sup>+</sup> - Force 3 on drag screen
- F6<sup>+</sup> - Force on drag disk
- P3 - Absolute pressure at scanning densitometer
- P4 - Absolute pressure at dual beam densitometer
- P5 - Absolute pressure downstream of turbine meter
- Q1<sup>+</sup> - Turbine meter reading
- R1<sup>x,+</sup> - Dual beam densitometer - upper beam reading
- R2<sup>x,+</sup> - Dual beam densitometer - lower beam reading
- T3 - Fluid temperature at scanning densitometer
- T4 - Fluid temperature at drag device
- T6 - Metal temperature at densitometer
- T9 - Fluid temperature downstream of turbine meter
- x - Measurements also routed to IRB analog tape recorder
- + - Measurements routed to EG&G Idaho, Inc., analog tape recorders



Measurement not processed by EG&G Idaho, Inc., computer

INEL-A-8675-1

Figure 15. EG&G Idaho, Inc., Computer Processed Test Section Transducers.

- D1\* - Steam orifice low range differential pressure
- D11\* - Steam orifice high range differential pressure
- D2\* - Water orifice low range differential pressure (mixing) or high range large boiler (throttling)
- D12\* - Water orifice high range differential pressure (mixing)
- D19 - Water orifice high range differential pressure (small boiler throttling)
- D20 - Water orifice low range differential pressure (small boiler throttling)
- P1\* - Steam absolute pressure
- T1 - Steam temperature
- T2 - Water temperature large boiler throttling, both - mixing
- T20 - Water temperature small boiler throttling
- \* - Measurements routed to EG&G Idaho, Inc., analog tape recorders

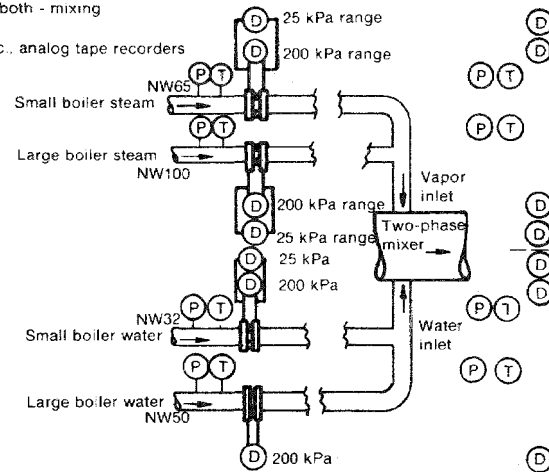

Transmitter	Computer channel	Contacts	EG&G Idaho, Inc.		
			Mixing	Throttling	Throttling
			Small boiler on steam	Small boiler on water	Both boilers on water
7	54	88/89	D-1	Not used	Not used
6	53	91/92	D-11	Not used	Not used
11.A4	55,56	85/86,	P-1,T-1	Not used	Not used
9.A2	59,60	67/68,	Not used, Not used	P-1,T-1	Not used
2	57	73/74	Not used	D-11	Not used
3	58	70/71	Not used	D-1	Not used
5	47	79/80	Not used	D-2	D-20
4	46	82/83	Not used	D-12	D-19
10.A3	48,49	76/77,	Not used, Not used	Not used, T-2	Not used, T-20
8.A1	51,52	61/62,	Not used, T-2	Not used, Not used	Not used, T-2
1	50	64/65	D-2	Not used	D-2

Figure 16. Single Phase IRB Transducer Setup.

Summarizing, the main body of test data came from the various types of transducers shown in Figures 15 and 16, through the EG&G Idaho, Inc., signal conditioning (equipment) to the data acquisition computer, as shown in Figure 14. Certain of these channels were also recorded on the EG&G Idaho, Inc., analog tape recorders as a means of providing backup data. Further, the recorded signals were simultaneously played back to six-channel strip chart recorders to verify that the backup data existed and were valid. Parameters thus recorded are noted in Figures 15 and 16, and were mainly the principal measurements described below.

## 1.1 Common Components

The hardware components common to the main body of data were the signal conditioners and amplifiers, the analog-to-digital conversion cards, the computer and teletype, the analog tape recorders, time code generator, and six-channel strip chart recorders. These are described herein.

1.1.1 Signal Conditioners and Amplifiers. This equipment consisted of 40 channels of wideband, dc instrumentation amplifiers and transducer signal conditioners borrowed from the Semiscale data acquisition system. The amplifiers are Bay Laboratories, Inc., Model 5204 and the conditioners Model 7442. Some characteristics of the amplifiers are given below:

Gain: 1 to 1000 (x 2.6 vernier)  
Input: differential, 100 megohm  
Output: single ended,  $\pm 10$  Vdc at 10 mA, dual outputs  
Common mode voltage:  $\pm 500$  Vdc  
Wideband output cutoff: 30 kHz (-3db)  
Filtered output cutoff: 50 Hz

Noise over 0.1 to 10 Hz is 1  $\mu$ V referred to input, with 99.9% confidence. The signal conditioners provided a six-wire, constant 5-volt excitation system for the absolute and differential pressure transducers. For all other measurements, the signal conditioners constituted a direct connection into the amplifier input.

1.1.2 Digital System. The digital system consisted of a set of Hewlett-Packard equipment: a 21 MX E-Series computer, three Model 91000A 16 channel analog to digital conversion (ADC) cards, a papertape reader, and a teletype.

The three Model 91000A, ADCs, were mounted in the computer mainframe input/output slots. Each card had 16 single-ended inputs connected to the filtered outputs from the Bay Laboratories, Inc., amplifiers. Characteristics of the ADCs are

Resolution: 12 bits, including sign  
Input:  $\pm 10.0$  V, full scale; 5 megohm  
Maximum Throughput rate: 20,000/s via DMA  
Overall accuracy:  $\pm 0.1\%$  full scale,  $\pm 1/2$  least significant bit

The Model 2109A, computer, was supplied with a 32 thousand word memory and incorporated both fast processor and fast memory options. System cycle time for this 16 bit memory was 560 ns. A paper tape reader, Model 2748B, and a standard teletype, Model 2752A, were supplied as the only accessories.

1.1.3 Analog Recording System. This system consisted of three analog magnetic tape recorders, three 6-channel strip chart recorders, and a time code generator translator.

The three tape recorders were Ampex Model FR-1300s, the strip chart recorders were Brush Model 260s, and the time code generator a Datum Model 9310. The wideband outputs from the Bay Laboratories amplifiers were connected to the 14-channel tape recorders. Characteristics of the tape recorders are:

Number of channels: 14  
Tape speeds: 1-7/8 to 60 inches per second (ips)  
Frequency response: 50 Hz to 10 KHz @ 1 7/8 ips  
with signal/noise = 25 db  
filtered, 18 db unfiltered  
(Direct Record/Reproduce  
System)

The strip chart recorders, used to verify the presence and correctness of signal on the analog tapes, were 6 channel units having 1 to 125 mm/s chart speeds with 1 mV per division to 500 Vdc full scale measuring ranges. The time code generator was used to relate test run and position on tape of data recorded during that run. The generator time for each test run was recorded on the operating log sheet.

## 1.2 Software

The software<sup>4</sup> was modular, consisting of several relocatable binary punched paper tapes covering the needed housekeeping, data acquisition, validation, and output functions. The simple hardware system supported only a Fortran II compiler and the Hewlett-Packard basic control system (BCS) operating environment. Because of its anticipated complexity and length, however, the program was written in Fortran IV and thus could only be compiled on a disk-based system. This made program changes more difficult, but thereby helped to reduce the number of unnecessary modifications.

1.2.1 Data Acquisition Function. The two-phase fluid conditions were expected and found to be stationary, that is, the time average values were not time-dependent. Thus, "on-line" validation of the self-consistency of various time-averaged parameters could be attempted at the expense of data acquisition sampling speed. The loosely stated criteria for speed and duration were: sampling must be done at a frequency high enough to avoid significant aliasing problems and for a duration long enough to average out the lowest frequencies. The software and hardware combined to give about 20 samples per second

on each channel and a sampling duration of about 30 s to get all of the 1000-sample average values. These conditions proved to be adequate. The number of channels involved tended to vary somewhat but generally was in the range of 40 to 50. A channel consisted of either a hardware channel (one of the possible 48 ADC inputs) or a software channel ("pseudo channel") which was an "instantaneous" variable calculated from one or more hardware channels, for example, a superheated steam specific volume calculated from a measured steam pressure and temperature. The program was set up to eliminate unsupported pseudo channels. For example, since the steam specific volume is a function of both steam pressure and temperature, the specific volume would not be calculated if either the pressure or temperature were not being measured. Further, since the mass flow of steam depends on the specific volume, if the specific volume were not calculated then the mass flow would not be calculated. For this reason the number of channels varied on occasion.

The acquisition process, incorporated in routine GDATA (Appendix A) consisted of the following:

1. Fetch digitized voltages (up to 48) from the ADC.
2. Convert the voltages to "instantaneous" engineering units using the calibration equations.
3. Calculate active pseudo channel "instantaneous" values using the pseudo channel equations (Appendix B).
4. Using the "instantaneous" values, update the average value of active hardware and pseudo channels.
5. Repeat steps 1 through 4 until the requested number of samples in the average values have been obtained.

The rate at which the digitized voltages were generated was the 20,000/s characteristic of the ADC. But the effective sampling rate depended on the number and complexity of pseudo channel calculations, that is, the time needed to perform steps 1 through 4. The most complex pseudo channel calculation was the superheated steam mass flow, and as this calculation was always made, the effective sampling rate was essentially constant.

1.2.2 Data Validation Function. Validation of the average values obtained in GDATA was covered by three computer routines: PDATA, CDATA, and SDATA (see Appendix C). These routines were conducted while the fluid conditions were held constant, so that invalid data could be discovered and eliminated and GDATA rerun if necessary. Thus the data validation was done in an "on-line" mode as far as the fluid conditions were concerned, but off line relative to the data acquisition process. The three routines covered data validation in the following respects:

- PDATA - 1. Verification that specified matrix point is reached
- 2. Test section mass conservation
- 3. Test section energy conservation.
  
- CDATA - 1. Two-phase flow self-consistency checks
- 2. Single-phase flow instrument checks
- 3. Two-phase mass flow rate calculations.
  
- SDATA - 1. Stationary condition of steam flow, water flow, and test section pressure.

Mass and energy conservation equations (see Appendix B) were to be used in conjunction with single phase mass flow measurements at the outlet of the test section as a means of verifying the correctness of measured steam and water flow rates going to the mixer. These basic validation calculations could not be accomplished because the single phase mass flow outlet measurement spools could not be installed in the facility in time for the EG&G Idaho, Inc., testing. Allowance was made in the header for each new run to specify the superheated steam and subcooled water flow rates and test section pressure. These values were then compared with the actual measured values to verify that the facility operator had successfully reached the matrix point.

In CDATA, self consistency checks were made as follows:

Saturation: Nearby pressure and temperature measurements were checked by calculating the saturation temperature corresponding to the measured pressure and computing the difference between it and the measured temperature. Such checks were also run on the conditions at the single phase measuring orifices to verify existence of at least minimum superheat and subcooling.

Differential Pressure: Checks were made using redundant, differential and absolute pressures. For example, as shown in Figure 15, the difference between D5 and the sum of D3 and D4 was calculated to verify that the difference was within the expected error band of the three measurements.

Single-phase (calibration) checks were able to be made of the turbine meter, dual beam densitometer, drag device, and differential pressure measurements. The single phase mass flow rate (orifice) measurement was used as a reference to check the turbine meter signal and specific volume calculation at the test section. Likewise, the single-phase densitometer values could be checked there against the

specific volume calculated from pressure and temperature measurements. The constancy of single phase drag coefficients and pressure drop (equivalent frictional resistance, K-factor) values could also be checked through the use of mass flow rate and specific volume measurements.

The two-phase mass flow rate was calculated using simple turbine, densitometer, and drag device models, and compared with the sum of the steam and water flow rates to the mixer.

In SDATA, the number of samples in the average was reduced to 100 and the resulting average values of steam and water flows and test section pressure immediately typed on the teletype. The time to print out the numbers thus controlled the sampling rate. A later modification to the program permitted any four hardware or pseudo channels to be selected for observation.

1.2.3 Other Functions and Routines. In total, a set of seven tapes were generated:

<u>Tape No.</u>	<u>Function</u>	<u>Routine</u>
1.	Main	- Main
2.	Housekeeping	- List, edit, read and punch housekeeping; read, edit and punch header
3.	Acquisition	- GDATA
4.	Validation and Printout	- PDATA, CDATA, SDATA, ZOUT
5.	Library	- Fortran IV
6.	Library	- BCS relocatable floating point
7.	Miscellaneous	- PSCAN, PCK, LEAD, SN, CHNG, I2313

The Housekeeping (HKP) routines provided the calibration constants and type of calibration equation, along with a listing of active hardware and pseudo channels and other standard information necessary to the computation. The Header (HDR) routines provided information on type of run, global parameters (such as number of samples in average), header information for each run, and specified matrix point data. The program accounted for five types of fluid conditions and three EG&G Idaho, Inc., program test series (LOFT, PBF, and Semiscale). The fluid conditions recognized were:

- 1) Calibration check - all vapor
- 2) Calibration check - all liquid
- 3) Two-phase condition achieved by throttling hot water
- 4) Two-phase condition achieved by mixing steam and water
- 5) Two-phase condition achieved by mixing air and water.

The ZOUT routine provided for data output. Options included printing or punching and metric or English units. All active hardware and pseudo channel time-averaged values from GDATA were listed. To check that the information on the punched tape was correct, the tape was read back into memory and the two versions compared. If the tape was correct, the computer responded with a "Tape Verified" output. Figure 17 is a copy of the standard GDATA printout for each run.

## 2. PRINCIPAL MEASUREMENTS

The principal measurements are:

1. Superheated steam flow to mixer,  $\dot{m}_S$
2. Subcooled water flow to mixer,  $\dot{m}_W$
3. Semiscale spool piece absolute pressure, P4
4. Spool piece fluid temperature, T4
5. Turbine meter flow, Q
6. Upper and lower beam chordal average densities,  $\rho_U$ , and  $\rho_L$
7. Drag device momentum flux,  $\rho_U^2$
8. Scanning densitometer cross sectional average density,  $\bar{\rho}$
9. Radiotracer liquid and vapor velocities,  $u_S$ , and  $u_W$
10. Upper and lower impedance probe void fractions,  $\alpha_U$ ,  $\alpha_L$

These measurements are listed in Table A-II except that only the sum of the flows to the mixer is listed. (Separate steam and water flows are given in Table A-III). The principal measurements are discussed below in terms of Single Phase (Items 1,2), Semiscale Spool Piece (Items 3 to 7), and Other (Items 8 to 10).

### 2.1 Single Phase Flow Measurements

The single phase measurements were important because they constitute the reference against which to judge the accuracy of the two-phase mass flow inferential measurement combinations (turbine + densitometer, turbine + drag device, and densitometer + drag device). For this reason, backup measurements were made with the EG&G Idaho, Inc., data acquisition system, in addition to those made by the IRB facility system. The IRB pressure, temperature, and orifice differential pressure transducers shown in Figure 16 produced a 0 to 20 mA signal. A precision resistor was inserted in the current loop from each transducer to the IRB data acquisition equipment and the voltage change across this resistor was amplified and measured by the EG&G Idaho, Inc., data acquisition system. Table 1 shows the agreement achieved by the two measuring systems (average difference

CURRENT TSN = 2287 NEW TSN = ?

2287

2287

TSN 2287 SEMISCALE STEAM WATER TEST. 15 DEC 77.

13

NAME	OUTPUT	UNITS
P 1	565.3406	KP
P 3	348.2294	KP
P 4	351.6051	KP
P 5	341.7297	KP
D11	38.1690	KP
D 1	31.2953	KP
D 3	.4108	KP
D 4	9.4304	KP
D 5	9.8270	KP
D12	.0000	KP
D 2	84.9411	KP
F 2	1102.5051	KG/M-S**2
D 6	.2683	KP
D 7	9.6696	KP
D10	1.4526	KP
T 4	150.7694	C
T 1	179.0914	C
T 2	135.4232	C
T 3	150.1535	C
T 6	149.7607	C
T 9	148.6732	C
P 1	9.2993	KG/CU M
P 2	277.0684	KG/CU M
Q 1	.0215	CU-M/S
F 1	1422.1345	KG/M-S**2
F 3	22.0830	KG/M-S**2
TS1	156.5302	C
TS3	138.6905	C
TS4	139.0275	C
VS	.3554	CU-M/KG
HS	2807.8125	J/G
VW	.0011	CU-M/KG
HW	569.9625	J/G
MS	.1728	KG/S
MW	3.2885	KG/S
VS4	.5396	CU-M/KG
VW4	.0011	CU-M/KG
MOM FLX	2639.9897	KG/M-S**2
VMS4	.0161	
VMW4	.0118	
RHOBAR	143.1839	KG/CU-M
UBAR	6.1508	M/S
M.D+T	3.1602	KG/S
M.D+DS	2.0780	KG/S
M.T+DS	1.6566	KG/S

3.4613

VERIFY TAPE: PLACE TAPE IN READER AND CHANGE SW WHEN READY

Figure 17. Data Acquisition Printout.

TABLE I

GfK SENSOR CHECK COMPARISONS OF MEASURED SIGNALS  
AT 20%, 50%, and 100% OF FULL SIGNALS

NW	TM	Comp	Term Strip	20% (4 mA) Full Scale				50% (10 mA) Full Scale				100% (20 mA) Full Scale			
				GfK	1.6 GfK	EG&G	% Difference	GfK	1.6 GfK	EG&G	% Difference	GfK	1.6 GfK	EG&G	% Difference
	10	48	76/77	0.9976	1.596	1.600	0.251	2.4872	3.980	3.995	0.377	4.9780	7.965	7.990	0.314
32	4	46	82/83	0.9951	1.592	1.593	0.053	2.4872	3.980	3.980	0	4.9756	7.961	7.958	-0.038
	5	47	79/80	0.9951	1.592	1.595	0.178	2.4872	3.980	3.981	0.025	4.9780	7.965	7.960	-0.063
50	8	51	61/62	0.9927	1.588	1.597	0.567	2.4847	3.976	3.991	0.377	4.9780	7.965	7.983	0.226
	1	50	64/65	0.9951	1.592	1.595	0.178	2.4872	3.980	3.980	0	4.9780	7.965	7.954	-0.138
	11	55	85/86	0.9951	1.592	1.595	0.178	2.4872	3.980	3.992	0.302	4.9780	7.965	7.985	0.251
65	6	53	91/92	0.9951	1.592	1.595	0.178	2.4872	3.980	3.985	0.126	4.9756	7.961	7.970	0.113
	7	54	88/89	0.9976	1.596	1.591	-0.313	2.4872	3.980	3.984	0.101	4.9780	7.965	7.966	0.013
	9	59	67/68	0.9951	1.592	1.595	0.178	2.4872	3.980	3.989	0.226	4.9780	7.965	7.975	0.126
100	2	57	73/74	0.9951	1.592	1.595	0.178	2.4872	3.980	3.985	0.126	4.9780	7.965	7.969	0.050
	3	58	70/71	0.9927	1.588	1.595	0.441	2.4872	3.980	3.985	0.126	4.9780	7.965	7.965	0

0.18%). The 1.60 factor in the table reflects the ratio of GfK and INEL resistor values. Thus the minor differences which occasionally appear between the  $\dot{m}$  values listed in Table A-I (IRB) and Table A-II (EG&G Idaho, Inc.,) must be ascribed to data acquisition technique, software, and steam tables.

As noted earlier (Section II), the highly flexible GfK system permitted a daily decision on which boiler would provide steam to the mixer and which would provide water. Figures 16 and 11 show the details and consequences of this decision. For example, Figure 11, the log sheet for December 15 testing, indicates that measurement spools NW 65 and NW 50 were used. Figure 16 shows that this choice meant the small boiler (Henschel) would provide the steam, and the large boiler (Benson) the water. Thus, GfK transmitters 7, 6, 11, and A4 would provide the steam data and 8, A1, and 1 the water data. In turn, the EG&G Idaho, Inc., computer would list the steam data as D1, D11, P1, and T1, respectively, and the water data as T2 and D2 (water pressure was not used in determination of its density in the EG&G Idaho, Inc., program). As shown in Figure 11, this correspondence required, for example, that GfK transmitter 11 be connected to EG&G Idaho, Inc., Bay Laboratories amplifier channel 1 for measurement P1, that transmitter A4 be connected to amplifier channel 21 for T1, etc.

Thus, if on the previous day the small boiler had provided water, the wiring connections to the EG&G Idaho, Inc., amplifiers would have to be changed to the new conditions. This selection was further verified on the log sheet (Figure 11) by crossing out the unused GfK instruments.

An additional decision had to be made concerning the flow measurement, since two differential pressure transducers were connected across each orifice plate. For example, the low range steam transducer (25 kPa full scale) was designated D1, the higher 200 kPa range, D11. The EG&G Idaho, Inc., computer program selected the higher range transducer unless its reading was less than 10% of full scale, in which case the low range transducer reading was used. Both values were measured and recorded regardless of which was used in the mass flow calculation (and thus it is not unusual to find the low range transducer reading greater than its full scale value).

The orifice equations used to compute the steam and water flow rates are those recommended in Reference 4, and are:

$$\dot{m}_s = 1890 C_{Ds} F_s D_{Ts}^2 F_{as} Y_a \left( D1/V_s \right)^{1/2}, \text{ lb/hr} \quad (1)$$

$$\dot{m}_w = 1890 C_{Dw} F_w D_{Tw}^2 F_{aw} \left( D2/V_w \right)^{1/2}, \text{ lb/hr} \quad (2)$$

where

$C_{Ds}, C_{Dw}$  = discharge coefficients for the steam and water orifices

$$F_s, F_w = \left(1 - \beta_s^4\right)^{-0.5}, \left(1 - \beta_w^4\right)^{-0.5}$$

$$\beta_s, \beta_w = D_{Ts}/D_{Ps}, D_{Tw}/D_{Pw}$$

$D_{Ts}, D_{Tw}$  = throat diameters for steam and water orifices, in.

$D_{Ps}, D_{Pw}$  = pipe inside diameters for steam and water orifices, in.

$F_{as}, F_{aw}$  = thermal expansion factors for steam and water orifice throat diameters

where  $F_{as} = a_0 + a_1(T1)$ ,  $F_{aw} = b_0 + b_1(T2)$  and  $a_0, a_1, b_0, b_1$ , are thermal expansion coefficients (Table II)

$$Y_a - \text{compressibility factor} = 1.0 - \frac{0.41 + 0.35 \beta_s^4}{1.3} \frac{D1}{P1}$$

$D1$  (or  $D11$ ) = steam orifice pressure drop, psia

$D2$  (or  $D12$ ) = water orifice pressure drop, psia

$V_s, V_w$  = specific volume of steam or water  $\text{ft}^3/\text{lb}$   
(steam

table algorithms are listed in Appendix B).

Values of discharge coefficients, throat and pipe diameters, thermal expansion coefficients and transducer calibration constants for the four measurement spools are given in Table II. As implied above in the software description, the quantity averaged was  $\dot{m}_s$  or  $\dot{m}_w$ . That is, "instantaneous" values of  $P1, T1, D1$ , in engineering units, were used to calculate similar values of  $F_{as}, Y_a$  and  $V_s$ . Then the value of  $\dot{m}_s$  was calculated according to Equation (1). This value was then used to update the average  $\dot{m}_s$  value. Thus, while the time-averaged values of  $V_s, P1, T1$ , and  $D1$  are also recorded, those average values were not used to calculate the average  $\dot{m}_s$  value.

The various measurement spools and associated instruments, that is, NW 65, NW 50, etc. were earlier calibrated in W. Germany. These tests resulted in the values of discharge coefficients, transducer calibration coefficients, etc., listed in Table II. The result of the analysis of the calibration data is that, the 95% confidence level for the steam mass flow rate measurement is  $\pm 2\%$  and for the water mass flow rate measurement is  $\pm 1\%$ . These are percentages of the reading and are considered valid down to 0.024 kg/s steam flow at 25 bar and 0.164 kg/s water flow. At lower pressures and flows, accuracy of the flow-measurements decreases.

TABLE II

SINGLE PHASE SPOOL MEASUREMENT CONSTANTS

Spool No.	Fluid	Bay Lab Gain	Press. Trans. Coefficients		Bay Lab Gain	Temperature Coefficients				Bay Lab Gain	Low Range ΔP Coefficients		Bay Lab Gain	High Range ΔP Coefficients		Discharge Coefficient C <sub>DS</sub> or C <sub>DW</sub>	Throat Diameter mm	Pipe Diameter mm
			a <sub>0</sub>	a <sub>1</sub>		a <sub>0</sub>	a <sub>1</sub>	a <sub>2</sub>	a <sub>3</sub>		a <sub>0</sub>	a <sub>1</sub>		a <sub>0</sub>	a <sub>1</sub>			
NW 32	Water		not used		500	32,90.56,-0.3144,0.00576	2	0, 0.05664	2	0, 0.45313	0.6205	15.00	32.80					
NW 50	Water		not used		500	32,90.56,-0.3144,0.00576		none	2	0, 0.45313	0.6165	23.00	50.90					
NW 65	Steam	2	10.43	299.06	500	32,90.56,-0.3144,0.00576	2	0, 0.05664	2	0, 0.45313	0.6127	27.90	68.10					
NW 100	Steam	2	10.43	299.06	500	32,90.56,-0.3144,0.00576	2	0, 0.05664	2	0, 0.45313	0.615	44.05	99.50					

Usage Summary

	Condition	Test Dates	Run	
Mixing:	Small boiler on Steam (NW 65) Large boiler on Water (NW 50)	6-9,13,15 19,21 Dec	2215-2247 2249-2264 2284-2302 2303-2313A	For spool number NW 32 thermal expansion coefficient for water = 1 and b <sub>0</sub> b <sub>1</sub> = (7.05 x 10 <sup>-6</sup> ) For spool number NW 50 thermal expansion coefficient for water = 1 and b <sub>0</sub> b <sub>1</sub> = (9.66 x 10 <sup>-6</sup> )
Mixing:	Small boiler on Water (NW 32) Large boiler on Steam (NW 100)	5,14,20 Dec	2209-2213 2265-2283 2313-2336	For spool number NW 65 thermal expansion coefficient for steam = 1 and a <sub>0</sub> a <sub>1</sub> = (11.6 x 10 <sup>-6</sup> ) For spool number NW 65 thermal expansion coefficient for steam = 1 and a <sub>0</sub> a <sub>1</sub> = (18.7 x 10 <sup>-6</sup> )
Throttling:	Both boilers on Water (NW 32, NW 50)	--	--	

## 2.2 Semiscale Spool Piece Instrumentation

The principal measurement instruments on the spool piece were the turbine meter, dual beam densitometer, three probe drag screen or drag disk, absolute pressure transducer, and fluid temperature thermocouple.

2.2.1 Turbine Meter. The turbine meter was a standard<sup>6</sup> Semiscale full flow device Model FT-48I 200-LBS, purchased from Flow Technology. The five-blade turbine rotor was mounted to a centrally located round rod axle by use of a ball bearing (see Figure 9). Both upstream and downstream of the rotor, the axial rod supported and aligned cross-shaped flow straighteners within a circular shroud. The inside diameter of the 19.7 cm long shroud, except near the rotor, was the same as that of the upstream 3-in. Schedule 160 pipe spool piece. The outer diameter of the rotor blades was 6.25 cm, with the shroud inner diameter at that location being 6.36 cm. Outer diameter of the rotor hub was 2.06 cm and the axial rod diameter was 0.635 cm. Nominal rated range of the unit was 40 to 400 gpm. While the flow was always unidirectional, both pickup probes needed to detect reverse flow were installed and connected to the signal conditioning unit, Model PRI-102FR.

The pickup probe is a detector which produces a voltage pulse as each rotor blade passes it. Thus, five pulses indicate one complete rotor revolution which in turn corresponds to a certain volume of fluid passing through the turbine meter. The calibration factor, then, is a certain number of pulses per unit volume. The signal conditioning module integrates the pulse train from the detector to produce an output analog voltage corresponding to the pulse rate or volumetric flow rate, and this in turn is further amplified by the Bay Laboratories amplifier (gain of 2).

Two turbine rotors were used in the testing; each was previously calibrated in the manufacturer's ballistic flow calibration facility. This facility uses an organic fluid of composition given by MIL-SPEC-7024B with a specific gravity of approximately 0.76. The turbine rotors were calibrated both with and without the EG&G Idaho, Inc., drag disk installed in its normal upstream position (the drag screen was not available for use at the time the turbine rotors were calibrated so that its effect on the turbine reading was not determined). The results of the turbine calibrations, given in Table III, indicate negligible effect of the drag disk on the turbine calibration in an all-liquid condition. On the basis of these results, the effect of the drag screen on the turbine was assumed to be negligible, since it would presumably disturb a flow less than the drag disk.

The signal conditioning module incorporated a five-position range switch, each of the first four ranges accommodating a full scale input pulse rate twice that of the preceding one. The highest range was a factor of 10 greater than the lowest range. Full scale pulse rates, volumetric flows, and (linear) engineering units conversion

TABLE III  
TURBINE METER CALIBRATION INFORMATION

<u>Condition</u>	<u>Turbine Meter Calibration Factor, Pulses/Gallon</u>
Turbine Rotor #48115A only	51.77
Turbine Rotor #48115A with #2427 Drag Disk upstream	51.61
Turbine Rotor #48115B only	51.62
Turbine Rotor #48115B with #2427 Drag Disk upstream	51.63

<u>Range</u>	<u>Full Scale Pulse Rate, p/s</u>	<u>Full Scale Output Voltage (amp. gain = 2)</u>	<u>Full Scale Volu. Flow ft<sup>3</sup>/s</u>	<u>Eng. Units<sup>a</sup> Coefficient, a<sub>1</sub> ft<sup>3</sup>/s, volt</u>
1	215.4	10	0.557	0.0557
2	430.8 <sup>b</sup>	10	1.114	0.1114
3	861.6	10	2.228	0.2228
4	1723.2	10	4.456	0.4456
5	2154.0	10	5.570	0.5570

a calibration equation for engineering units conversion is  $Q = + a_1 (V)$ ,  
 $Q, \text{ft}^3/\text{s} = + a_1 (V, \text{volts})$ .

b  $(51.7 \text{ pulses/gal}) (1.114 \text{ cu ft/s}) (7.48 \text{ gal/cu ft}) = 430.8 \text{ pulses/s}$

coefficients used in the computer are also given in Table III. An initial mistake in calculation of the values of  $a_1$  was subsequently discovered and all data involving values of  $Q$  in this report have been corrected. An apparent nonlinearity in the circuitry of the signal conditioning module was discovered during installation checks at Karlsruhe. (The module used in the ballistic calibration tests was not available and a second unit was taken to Karlsruhe.) The nonlinearity appeared at approximately 65% and greater of all ranges and was attributed to a circuit modification. The solution adopted was to use different ranges, as necessary, to keep the output voltage less than 60% of full scale.

A problem with the performance of the turbine meter was failure of the bearings, which led to destruction of the rotor (blades were broken off at the hub due to interference with the shroud inner diameter). The bearing failures observed were attributed to high temperature, high void fraction, and overspeed conditions. Because of the nature of the steady state testing, these adverse conditions were maintained for periods of time much longer (sixty times longer) than exist in a normal Semiscale test. As a result, though the fluid conditions in the steady Karlsruhe test and those in a normal Semiscale test were the same, the effect on the turbine meter was much more severe in the steady state tests. Over the course of the testing, both rotors and three sets of bearings were used up.

2.2.2 Dual Beam Densitometer. The single source/two detector or "dual beam" densitometer Semiscale system designation GU-15 was a Model FM-3 purchased from Measurements, Inc. The densitometer consisted of a Cesium-137 source housed in a storage cask mounted on the spool piece piping, two NaI(Tl) photomultiplier (PM) tube detectors in their casks, and two channels of associated electronics.

The 20 Curie Cesium-137 pellet was remotely moved from a "stored" location within the source cask to an "exposed" position by use of compressed air. In the latter position, the 662 keV gamma radiation from the pellet was able to pass through two collimating ports in the shield, the stainless steel pipe wall, contained fluid, far-side pipe wall, and through the detector collimating ports to the two NaI(Tl) crystals. The source and detector shield casks were mounted to the piping by a water cooled clamp and framework. Though the angle between detectors was fixed by collimators and detector cask mounting, the relation of the beam path to the pipe flow cross section was determined by adjusting the clamp relative to the pipe, using a flat on the clamp and a level to get the flat horizontal. Properly installed, the lower beam penetrated the pipe at the bottom of the flow cross section, while the upper beam formed an angle of 18 degrees with it, as shown in Figure 9.

Unlike the source cask which was constructed of depleted uranium, the two detector shield casks were made of lead filled steel. The detector shield casks were water cooled and contained the detectors and tube base preamplifiers. Remotely actuated (air) shim packages were mounted integrally with the detector collimating ports. Each

package contained two steel shims (Hi, Lo), separately controllable, with indicating lights on the control/amplifier. Position of the source pellet was also shown by indicator lights, and switches controlling solenoid valves which permitted application of air pressure to the source cask and shim packages were also mounted on the control/amplifier.

The detectors were 5.08 cm diameter by 5.08 cm high NaI(Tl) scintillation crystals integrally mounted to 5.08 cm diameter PM tubes. The 1.91 cm diameter collimated gamma beam struck the crystal along a radius of the cylinder. Only four dynodes of the ten stage tubes were used (one standard method of improving detector stability). The premium grade tubes were specially selected for low, dark current. The input capacitance of the tube base preamplifiers was such that the pulse train from the PM tube was basically integrated at that point and thus the preamplifier output was an analog voltage proportional to the pulse rate. This voltage was further amplified in the control/amplifier to produce a 10 volt full scale output. The signal was routed to a Bay Laboratories amplifier, set with a gain of 1.0. Highly stable Power Design units were supplied in the Measurements, Inc., systems to provide the two PM tube high voltages.

The detected pulse rate or output analog voltage from a detector channel is inversely proportional to the exponential of the number of mean free fluid path lengths. The number of such path lengths is itself directly proportional to the average fluid density along the chordal beam path through the fluid. Thus, two proportionality constants relate the pulse rate and chordal-average fluid density. Values for these two constants can be determined by measuring the pulse rates at each of two known fluid densities, as for example, an all-liquid condition and an all-vapor condition. This constitutes the calibration of the densitometer. The engineering units conversion equation used in the computer to calculate the chordal-average fluid density for each detector was:

$$R = A \ln \frac{B}{V - C} \quad (3)$$

In this equation, A and B are the proportionality constants, V is the measured output voltage, R the chordal average fluid density, and C a small correction to take account of radiation detected (with stored source) in spite of the source and detector shielding. No correction was made either for background or for scattered radiation detected. Values of the constants and other densitometer data are given in Table IV. The output voltage, V, is subject to the gain of the PM tube which in turn depends on the magnitude of the high voltage applied to it. The value of B is the output voltage, corrected by C, for the all-vapor condition, and hence is dependent on the high voltage setting for that measurement. The daily setup procedure finally adopted for the densitometer was to provide an all-liquid condition in the pipe at or near the expected operating temperature.

TABLE IV  
DUAL BEAM DENSITOMETER INFORMATION

---

Calibration Constants Used

<u>Detector</u>	<u>A, lb/ft<sup>3</sup></u>	<u>B, volts</u>	<u>C, volts</u>
R1 (upper beam)	206.24	9.986	0.005
R2 (lower beam)	120.66	9.953	0.005

<u>Item</u>	<u>Serial Numbers</u>	
	<u>R1</u>	<u>R2</u>
Amplifier	1037	1039
Detector	Z-879	Z-876
Preamp	A113	A114
Power Supply	B609013	B609012
Source Cask	18	--
Detector Cask	54	55

---

Test section fluid pressure and temperature measurements provided the means to calculate liquid density from the steam table algorithms (Appendix B) and the high voltage was adjusted to give that density value. Use of the all-liquid condition was not as desirable as an all-vapor condition, but the all-vapor condition could not be used without damaging the turbine meter. The problem found in using the all-liquid condition to check or reset the high voltage was that the output voltage drifted sufficiently under subsequent high void fraction conditions to produce calculated, negative densities. While this few-to-several-hour drifting was a problem in the steady testing at Karlsruhe, it is not in the normal Semiscale test. In the latter case, the high voltage can be adjusted just prior to the beginning of a blowdown, while the all-liquid condition exists. Within 6 to 8 minutes, the blowdown and reflood are complete and a known all-vapor condition exists which can be used to correct any drift. But in several hours per day of steady state testing, the drift was not negligible, and all-liquid conditions could not be repeatedly run during a day without a major reduction in testing rate. The use of the shims in this respect was not tried extensively, and might have helped the situation. The approach followed was that the scanning densitometer, not being subject to the drift problem, could be used to determine correct cross sectional average densities. Part of the drift problem was finally attributed to the upper beam PM tube starting to fail, and performance did improve somewhat after the PM tube was replaced.

2.2.3 Momentum Flux Measurement. As noted earlier, momentum flux measurements were initially obtained using a three transducer, full flow drag screen setup. Later in the test series a single transducer drag disk was used. The full flow drag screen was installed for Runs 2201 to 2302, and the drag disk for Runs 2303 to 2340. The three transducer drag screen setup was the prototype of a new Semiscale measurement system developed by EG&G Idaho, Inc., and these Karlsruhe tests were the first tests in which the system was subjected to a two phase flow. The commercial drag disk system has been in use on the Semiscale facility for some time, but because of flow regime and temperature sensitivity problems is to be replaced with the newer system.

A cross section of the drag screen setup is shown in Figure 9, Section B-B. The primary components are an instrument washer, drag screen, three force transducers, and carrier amplifier signal conditioning modules. The instrument washer is mounted between the spool piece flanges with silver plated Inconel-600 O-rings used for the pressure seal. A tongue and groove arrangement provides proper alignment of washer and spool piece inside diameters. Three water-cooled transducers are mounted in the instrument washer, the tip of the force arm of each transducer engaging the drag screen. As the transducers are mounted top, bottom, and side, the vertical drag screen actually rests on the force arm of the bottom transducer and is

prevented from tipping by the side and top transducer arms. Thus, the flow-induced-drag-force on the screen is resisted by the three transducer force arms. Each arm is part of a pivoted lever which in turn causes a slug to move within an electrical coil, changing the coil's reluctance. The changed reluctance produces a phase shift of the 3-kHz carrier signal. The phase shift is detected and amplified by the carrier amplifier, and its dc output is linearly related to force arm movement. Full scale movement is 1.27 mm, corresponding to a force on the arm of 31.1 newtons, and to an output voltage change of 2.00 volts. This carrier amplifier output signal was routed to the Bay Laboratories amplifiers and the remainder of the data acquisition system.

The sum of the forces on the drag screen is proportional to the momentum flux  $\rho u^2$  as can be seen in Figure 18 which shows, the momentum flux calibration of the screen. Table V lists calibration data. This calibration was done at the Semiscale air-water loop using a measured water flow only. It is to be noted that in this first system there was a non-zero offset (non-zero output signal for no applied force). In the testing at Karlsruhe, the offset values were generally checked at the beginning of the day for a non-flow condition, and these daily values were used for the remainder of that day. In several cases, offsets were checked at day's end and found to be somewhat different. The data in Table A-II reflect only the beginning values, a judgment of the validity and usefulness of attempting some correction being left to the subsequent analysis effort.

Both successes and failures were observed with the measurement. No significant temperature sensitivity was observed with these water cooled transducers, and this constituted achievement of a significant design goal. Also, some amount of flow regime information could be gleaned from consideration of the relative magnitudes of the three transducer outputs. On the other hand, all three force arm tips broke at one time or another during the testing. Part of these failures were subsequently attributed<sup>7</sup> to chloride induced stress corrosion cracking and part to alloy selection and possible inadequate heat treatments. It also became apparent that fine particles (corrosion and other foreign matter, or both) had settled and become packed around the force arm in the bottom transducer causing, finally, a loss of range and gradual loss of calibration (Subsequent designs have used side-side-top transducer orientation instead of the initial top-side-bottom one). Overall, the gains seemed to outweigh the losses and this prototype measurement system appeared to be relatively successful.

The drag disk measurement consists of a solid disk target mounted on a force arm. Disk diameter is 2.22 cm, compared to the 66.7 mm spool piece inside diameter. Because the disk is generally mounted at pipe center, it is unable to respond to stratified flow regimes with liquid levels below the bottom of the disk. In some early instances, the cross-sectional area of the force arm was significant compared to the disk area, causing calibration and interpretation problems. The

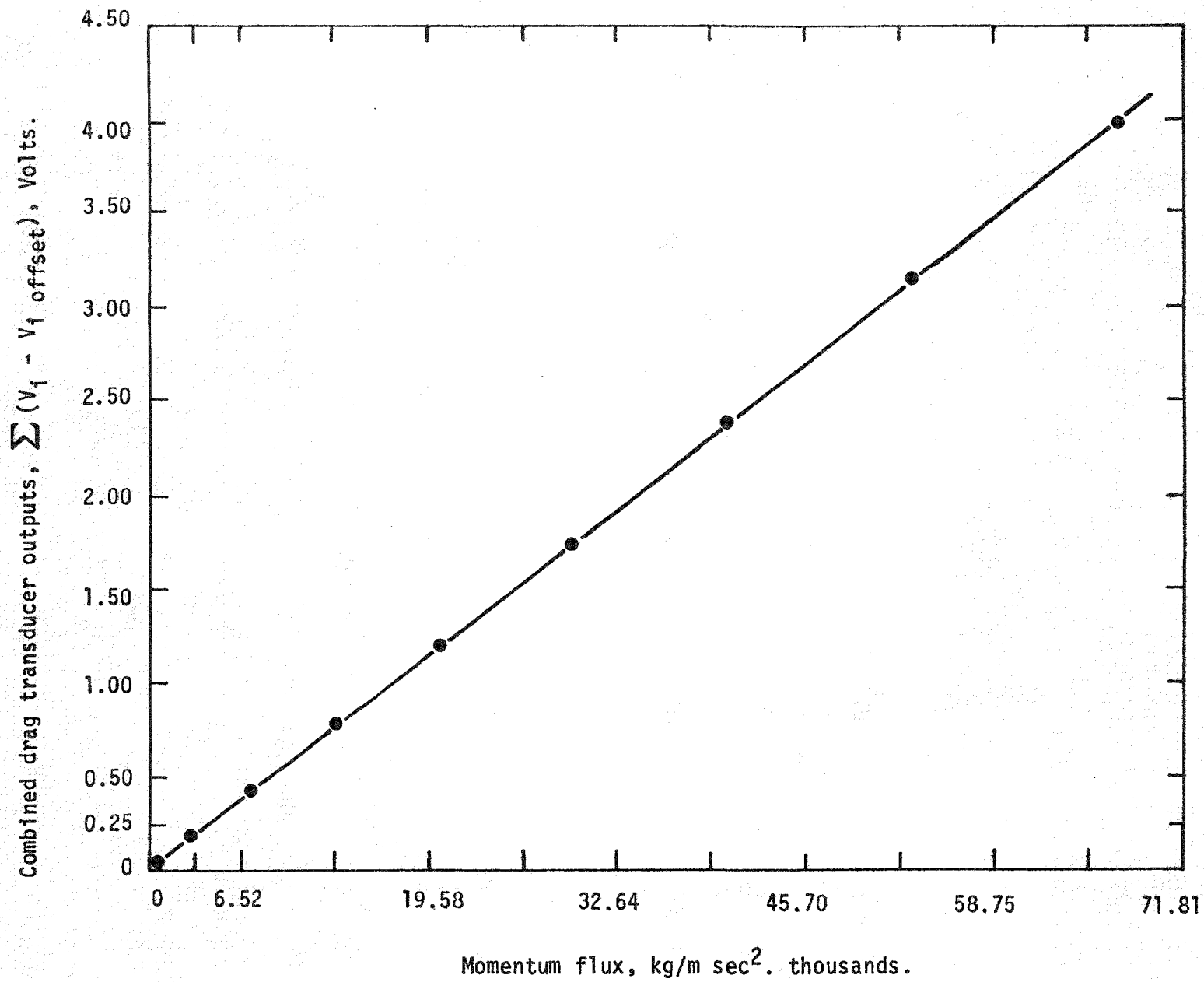

Figure 18. Drag Screen Momentum Flux Calibration.

TABLE V  
MOMENTUM FLUX CALIBRATION INFORMATION

Drag Screen Transducers

<u>Serial Number</u>	<u>Washer Location</u>	<u>Designation</u>	<u>Calibration Gain,<sup>a</sup></u>	<u>Constants Offset<sup>b</sup></u>
001	Bottom	F1	2270	V <sub>1</sub> off
002	Side	F2	2270	V <sub>2</sub> off
003	Top	F3	2270	V <sub>3</sub> off

Drag Disk Transducer

<u>Serial No.</u>	<u>Designation</u>	<u>Calibration Offset a<sub>0</sub></u>	<u>Constants Gain, a<sub>1</sub></u>
2427	F6	-66.96	1788

Drag Disk: Ramapo Model MARK V-5-PRBD

- a. Includes Bay Laboratories amplifier gain of 5; units: lbm/ft s<sup>2</sup>, volt.
- b. Checked daily and changed as necessary - see daily instrument log sheet. Calibration equation for engineering unit conversion is:

$$\rho_u^2 = a_1 \cdot \sum_{i=1}^3 (V_i - V_i \text{ off})$$

electrical part of the transducer is simpler than the drag screen transducers, being a strain gage type measurement. It was thus handled in exactly the same manner as a pressure transducer by the software. However, although simple, this strain gage is not provided with adequate cooling or temperature compensation which impairs the measurement accuracy significantly. Calibration data for the drag disk were obtained simultaneously with the turbine calibrations and are included in Table V. The transducer worked satisfactorily and without failure within the limitations noted.

2.2.4 Spool Piece Absolute Pressure. Figures 9, 10, and 15 show the location and connection of the absolute pressure transducer, designated P4, to the Semiscale spool piece. The pressure tap was located at the horizontal centerline of the spool piece at the upstream flange of the instrument washer joint. A standard Semiscale type water cooled pressure probe was used to assure that the sense line to the transducer was continuously filled with water. The transducer was mounted below the test section on the top rail of the test stand (Figure 10). The transducer was supplied with isolation and vent valves and was connected into the redundant  $\Delta P$  measurement network as shown in Figure 15.

Different transducers were used, depending on the matrix point pressures scheduled for the test day. A Baldwin Lima Hamilton (BLH) differential pressure transducer having 50 psid range was used with its low side open to the atmosphere for most of the 4 bar runs, whereas Precision Sensor absolute pressure transducers were used when test section pressures were 10 to 40 bars, and Consolated Elettrodynamics Corporation absolute units were used for 75- and 100-bar test section pressures. Constant voltage (5 volt) excitation of these various manufacturer's strain gage type transducers was used throughout the testing. As indicated earlier, the six conductor cabling and Bay Laboratories signal conditioners were common to all pressure measurements and independent of transducer used.

The pressure transducers were all calibrated at EG&G Idaho, Inc., prior to shipment to Karlsruhe. The calibration data were fitted by a least squares technique to a straight line. The resulting gain coefficient ( $a_1$ ) was used directly while the offset coefficient ( $a_0$ ) was adjusted, in the case of the absolute transducers, to account for the vertical elevation (of water filled sense line) between transducer and spool piece. These coefficients, the corresponding Bay Laboratories amplifier gain, and transducer make, serial number, and ID (P-4 in this case) were then listed on the instrument log sheet, as may be seen in Figure 11. Channel numbers for the Bay Laboratories amplifier, the Ampex tape recorder, associated strip chart and the Hewlett Packard ADC card were also listed on that log sheet. In some instances, backup transducers had to be used, as for example was the case for P-4 on the December 15 log shown in Figure 11. The pressure measurements were in general reliable and consistent with each other and with the temperature measurements.

2.2.5 Spool Piece Fluid Temperature. Figure 9 and 10 show the location and installation of the Semiscale spool piece fluid temperature measurement, T-4. However, in the Karlsruhe testing the resistance temperature bulb shown in Figure 9 was not used and the Chromel-Alumel thermocouple was located instead in its place, that is, in the downstream flange. As shown in both figures, the thermocouple was inserted from the top side of the spool piece flange and extended down into the flow to near the spool piece horizontal centerline. The thermocouple junction was made in the way normally done at the Semiscale facility: an exposed junction is formed and located about 1.5 cm from the sealed end of the 0.635 cm outside diameter stainless steel sheathing. Chromel-Alumel extension wire routed the signal to a 150°F reference junction. The resulting mV difference was then amplified and measured using the common front end analog and digital equipment. As with all the spool piece principal measurements, the temperature was also recorded on analog tape as a backup, as shown in Figure 11.

The thermocouple was not specifically calibrated. Instead, low tolerance thermocouple cable was purchased and used, and the Chromel-Alumel standard calibration curve was used in the computer to accomplish the engineering units conversion. The set of four coefficients used, listed in Figure 11, adequately covered the range of temperatures experienced in the testing.

### 2.3 Other Principal Measurements

The other principal measurements consisted of the scanning densitometer, the radiotracer measurements of phase velocities, and the impedance probe void fractions. The latter two measurements are described in detail elsewhere<sup>2</sup>; the data from all three measurements are included in Table A-2. The scanning densitometer is described herein.

The scanning densitometer was a low photon energy, moving - detector system (Figure 19) assembled and checked out at EG&G Idaho, Inc. Significant portions of the system were purchased from Westinghouse Nuclear Energy Systems where it had been used previously<sup>8</sup>. In the Karlsruhe testing, a new spool piece and traversing framework were built, a new source was supplied, and these were combined with the Westinghouse detector, electronics, and traversing motor and control to form the new system.

The spool piece was a 1.48-m length of 3-in. Schedule 160, Type 304 stainless steel pipe with Grayloc hubs at both ends and a flanged joint about 23 cm from the downstream end. A beryllium ring was mounted between these flanges and the joints sealed with silver-plated Inconel-600 O-rings. The nominal beryllium ring inside diameter was 66.7 mm with an outside diameter of 101.6 mm, was 19.05 mm thick, and fabricated of Brush-Wellman alloy S-200E. The flanges were specially fabricated with an 8 bolt pattern and with taps for pressure, temperature, and Storz lens connections. Three of the flange bolts were replaced by a pair of flange clamps (Figure 8) in

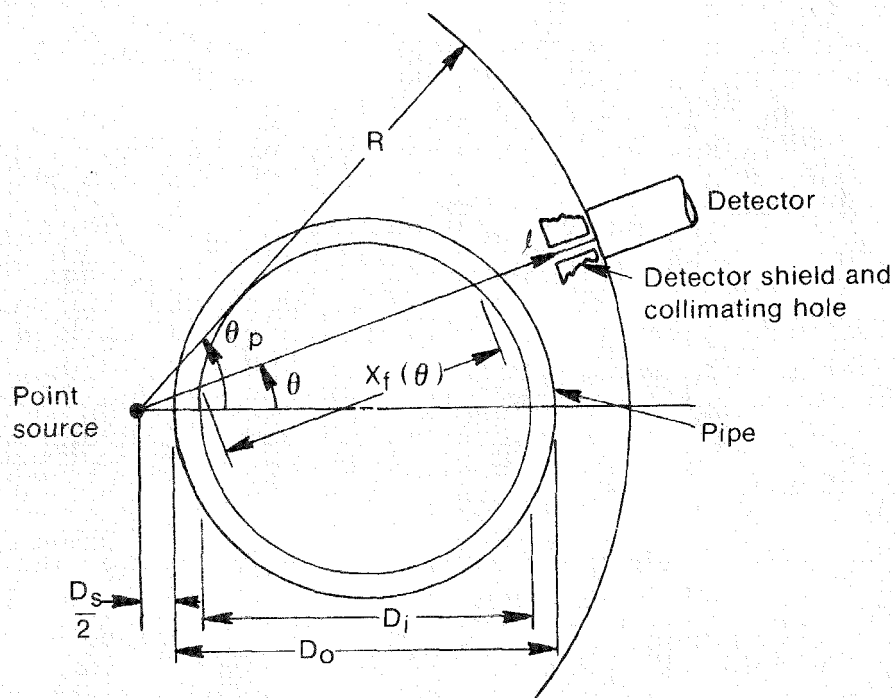

INEL-A-4211

Figure 19. Densitometer Source, Pipe, Detector Geometry.

order to permit the detector an unobstructed view of the entire flow cross section. The clamp bolts were at locations outside the traversing range of the detector. At the spool horizontal centerline, a 19.18 mm diameter hole was drilled in each flange at a distance of 7.620 cm from the center of the flange bore. A 19.05 mm diameter shaft (Figure 8), aligned like a flange bolt, was mounted through and between these holes, and served two functions: (1) it was the axle about which the detector rotated, and (2) it housed the radioactive source. An axial hole was drilled halfway down the shaft, and the source, mounted at the end of the source holder rod, was inserted in this hole. The wall of the tube, on the side nearest the beryllium ring, was cut away at the source location so that only air existed between the source and the beryllium ring. Thus, the source was not collimated. A roll pin was used to lock the source holder rod, axle/source tube, and the upstream flange in relative position. This assured that the source was maintained in a known, fixed position, relative to the beryllium ring, regardless of detector position.

The liquid nitrogen dewar and X-ray detector were mounted on a traversing frame constructed of rectangular aluminum tubing. At one end of the frame, vertical arms connected it to the axle/source tube. Sealed ball bearings were pressed into the arms and provided low frictional resistance between the stationary axle and rotating arms and frame. At the frame's outer end, a vertical circular arc segment was attached to the frame. A chain from the drive motor sprocket was attached to the bottom of the arc, so that pulling upward on the chain raised the detector. The chain unwrapped from the circular segment causing a detector movement linearly related to the rotation of the drive motor.

The radioactive source consisted of approximately 45 mCi of accelerator-grade Cd-109, prepared in May 1977 by New England Nuclear Company. The active material was electroplated on a silver disc which was housed in an hermetically sealed short cylinder, the ensemble noted as capsule Model LE-66A. The primary radiation is the 22.1 keV silver  $k_{\alpha}$  X-ray with a yield of better than 95% per disintegration.  $k_{\beta}$  X-rays are also present at 24.9 and 25.4 keV, as is an 88 keV gamma. The electron capture decaying isotope has a half life of about 453 days.

The detector was a 1.0-cm diameter by 5-mm active depth Si (Li) crystal, cooled to near liquid nitrogen temperature in a common vacuum 5 liter dewar, Ortec Model 78916-10300. The 3.81-cm diameter evacuated cryostat snout was sealed against the atmosphere with a 0.001 in. thick beryllium window. A detector shield was mounted on the front of the cryostat. It consisted of a lead sleeve and 25.4 mm thick shield. A rectangular collimating hole was machined in the shield and had a cross section 10 mm wide by 3.17 mm high. Thus, the collimating hole length-to-height ratio was approximately 8 to 1.

With the source/detector distance of 24.58 cm, the 3.17 mm collimating slot height corresponded to an angular beam height of 0.739 degrees, and constituted 1/20 of the flow diameter. Photon

energy resolution of the detector was 274 eV full width half maximum at 15,000 of the 22.1 keV X-rays per second with a main amplifier shaping time constant of 2  $\mu$ s.

Figure 20 is a block diagram of the pulse counting system and detector traversing control. Charge pulses generated in the detector by photoelectric absorption of incident X-rays are integrated and amplified in the preamplifier. These voltage pulses are inverted, shaped, and further amplified in the main amplifier and presented to the input of the single channel analyzer (SCA) dual discriminator. The pulse height is proportional to the absorbed X-ray energy, so a pulse height or X-ray energy window can be set by adjusting the upper and lower discriminators. If the pulses are of a height to fall in the window, a slow logic pulse is sent by the SCA to the dual counter/timer where it is counted. Pulses are counted for the selected preset time (that is, 10 s) set on the dual counter/timer. At the end of the preset time, the number of pulses counted is transferred by the printout control to the teletype. Upon completion of printout, the counter is reset to zero and counting automatically reinitiated. Also at the end of the preset time, a control signal is sent from the counter/timer to the preset indexer to start the detector traverse motor and move the detector to its next azimuthal position. The traverse motor is a precise, phase switched dc stepping motor whose output shaft turns 1.8 degrees per step (or preset indexer output pulse). When the preset number of steps (200) have been accomplished, power to the motor is turned off. The speed of the stepping motor is adjusted so that the detector is moved to its next position in slightly less time than is used by the teletype for data printout, that is, slightly less than 3 s.

Thus, a traverse is started by moving the detector to its initial position. The 22.1 keV pulses are counted for 10 s. and the number counted is typed on the teletype. While the typing is proceeding, the detector is moved by the stepping motor to position 2. The counter is reset and counting reinitiated at the new position. This procedure is repeated automatically for the 65 azimuthal detector positions, at which time the operator stops the process and returns the detector to its initial position for the next data run.

Main amplifier gain was set at 45 so that the 22 keV photons produced pulses of about 2.6 volts; thus the accompanying 88 keV gamma rays did not saturate the amplifier. Bias voltage used was -1500 Vdc, and upper and lower discriminators were set at 2.80 and 2.40 volts, respectively. A ratemeter connected at the SCA output drove a 10-in. strip chart recorder to provide traverse plots for ease of flow regime identification. A second SCA and ratemeter, and the second pen of the recorder were used to record the 24.9 keV X-ray photon count rate as a backup to the main measurement. A multichannel analyzer, Ortec Model 6240-04, was used in setup of the pulse height windows and to verify that scattering and background corrections were negligible. Dead time corrections were also found unnecessary at the counting rates encountered in these tests.

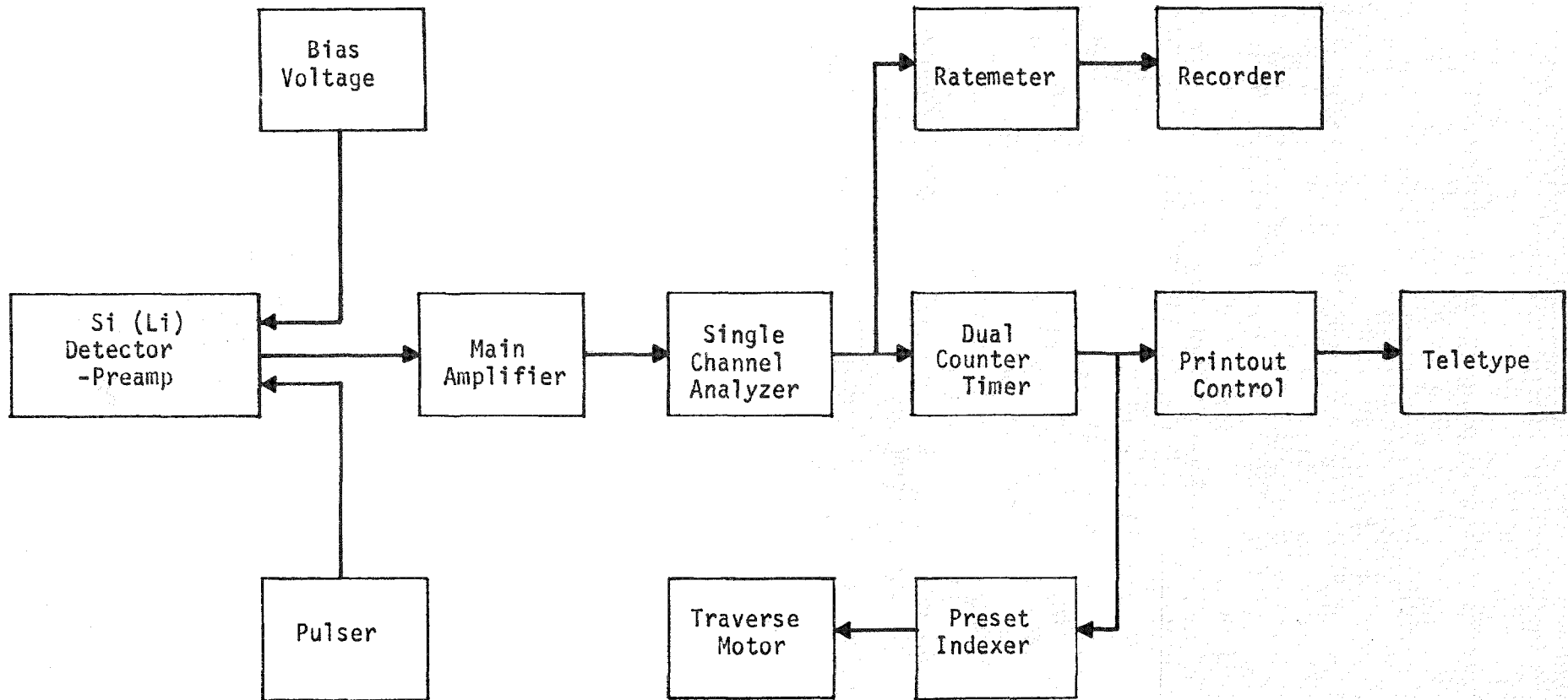

Figure 20. Scanning Densitometer Block Diagram.

As noted above, a total traverse consisted of obtaining data at 65 positions, each position separated by 200 preset indexer steps corresponding to an angular movement of 1.149 degrees. Thus, the 0.739 degree-wide interrogating window was moved the 1.149 degrees from position to position. Measurements of traverse angle were made for all 65 positions. The 1.149 degrees per 200 indexer steps represents the average angular displacement. Standard deviation of this measurement was 0.017 degrees. Data were obtained at several detector positions in the beryllium wall, outside the flow area. This was done as a means of verifying repeatable positioning of the detector, regardless of flow condition. As the total angular range covering the flow area was 54.32 degrees, two phase data were obtained at 47 positions.

Densitometer calibration was accomplished by obtaining count rate traverse data for known density, all-liquid and all-dry vapor conditions. Data were reduced using the scanning densitometer data reduction computer program, PATDR. Chordal average densities are calculated using Equation (4) and cross sectional average fluid density is calculated using Equation (5). The weighting factor used in the latter equation accounts for the angular segment beam area associated with the polar coordinate setup of source and detector.

$$\rho_c(\theta) = \rho_f - (\rho_f - \rho_g) \frac{\ln \frac{I(\theta)}{I_f(\theta)}}{\ln \frac{I_g(\theta)}{I_f(\theta)}} \quad (4)$$

$$\bar{\rho} = \frac{\sum_{i=1}^{47} [\rho_c(\theta_i) 0.5 (D_o + D_s) (\cos \theta_i) X_f(\theta_i) \Delta\theta]}{\sum_{i=1}^{47} 0.5 (D_o + D_s) (\cos \theta_i) X_f(\theta_i) \Delta\theta} \quad (5)$$

where

- $\rho_f$  = the density of the subcooled water giving rise to traverse count rates  $I_f(\theta)$
- $\rho_g$  = the superheated steam density yielding count rates  $I_g(\theta)$
- $\rho_c$  = the chordal average density determined from the two phase fluid count rates  $I(\theta)$
- $D_o$  = beryllium ring outer diameter
- $D_s$  = twice the distance from source center to nearest outer surface of beryllium ring

- $\theta$  = traverse angle (Figure 19)  
 $X_f$  = fluid chordal path length =  $(D_i^2 - (D_o + D_s)^2 \sin^2 \theta)^{1/2}$   
 $D_i$  = beryllium ring inner diameter.

### 3. Auxiliary Measurements

The auxiliary measurements are the quantitative pressures, temperatures, and differential pressures listed below, and the qualitative video tape recordings obtained with the Storz lens. The measurements are:

1. Drag device differential pressure, D3
2. Turbine meter differential pressure, D4
3. Drag and turbine differential pressure, D5
4. Upstream (frictional) differential pressure, D6
5. Total differential pressure (Figure 15), D7
6. Impedance probe differential pressure, D10
7. Absolute pressure at scanning densitometer, P3
8. Absolute pressure downstream of turbine meter, P5
9. Fluid temperature at scanning densitometer, T3
10. Spool piece metal temperature at dual beam densitometer, T6
11. Fluid temperature downstream of turbine meter, T9.

Values for these measurements are given in Tables A-III, A-IV, and A-V. Locations of the sensors are shown in Figure 15. As with all of the measurements processed by the EG&G Idaho, Inc., data acquisition computer, the calibration and other equations used in the computer are also given in the Appendicies.

#### 3.1 Pressure, Temperature, Differential Pressure

These pressure and temperature measurements provide backup for the ones on the Semiscale spool piece and also for phase densities at the scanning densitometer. The pressure measurements were processed as described above in Section 2.2.4, likewise the fluid temperatures as in Section 2.2.5. Calibration information is given in Table VI. The metal temperature was measured with an ungrounded, 1.52 mm diameter, stainless steel sheathed Chromel-Alumel thermocouple mounted in a well in the spool piece wall.

TABLE VI

PRESSURE, TEMPERATURE CALIBRATION INFORMATION

<u>Transducer Serial No.</u>	<u>Mfg. and Type</u>	<u>Range</u>	<u>Intended Application</u>	<u>Calibration<sup>a</sup> EG&amp;G Idaho, Inc. a<sub>1</sub></u>
39192	BLH- ΔP	20in. H <sub>2</sub> O	DP-06	2.732
42702	BLH- ΔP	50in. H <sub>2</sub> O	DP-03	3.364
71471	BLH- ΔP	50in. H <sub>2</sub> O	DP-04	6.711
44296	BLH- ΔP	300in.H <sub>2</sub> O	DP-07	20 633
44305	BLH- ΔP	300in.H <sub>2</sub> O	DP-02D	21.172
71446	BLH- ΔP	300in.H <sub>2</sub> O	DP-01B	41.040
77932	BLH- ΔP	300in.H <sub>2</sub> O	DP-05	41.127
43544	BLH- ΔP	10 PSID	DP-10	0.642492
50558	BLH- ΔP	10 PSID	DP-02B	0.667659
50194	BLH- ΔP	50 PSID	P-03-4bar	4.968
50196	BLH- ΔP	50 PSID	P-04-4bar	4.979
50197	BLH- ΔP	50 PSID	P-05-4bar	4.968
50198	BLH- ΔP	50 PSID	4bar BACKUP	4.971
384775	VIATRAN-P	100 PSIG	BACKUP	8.480
391975	VIATRAN-P	100 PSIG	P-01A	8.474
521	PS-P	500 PSIG	P-03-10,40bar	55.780
522	PS-P	500 PSIG	P-04-10,40bar	64.241
2611	CEC-P	1000 PSIG	P-05-10,75bar	63.008
2613	CEC-P	1000 PSIG	P-04-75bar	59.656
2253	CEC-P	2500 PSIG	P-03-75bar	156 37
2353	CEC-P	2500 PSIG	P-05-100bar	151.51
2734	CEC-P	2500 PSIG	P-04-100bar	155.64
3452	CEC-P	2500 PSIG	100bar BACKUP	143.73

Calibration equation for engineering units conversion:

$$P \text{ or } DP = a_0 + a_1 \text{ (volts)}$$

Thermocouples

<u>Type</u>	<u>Range</u>	<u>Application</u>	<u>a<sub>0</sub></u>	<u>a<sub>1</sub></u>	<u>a<sub>2</sub></u>	<u>a<sub>3</sub></u>
Chromel- Alumel	0-650°F	T-3,4,6,9	150 4	45.28	-0.1573	0.00288

Calibration equation for engineering units conversion is:

$$T = a_0 + a_1(V) + a_2(V)^2 + a_3(V)^3$$

a. Five volt excitation, English units

The separate differential pressure measurements across the impedance probe, drag device, and turbine meter were made in an effort to determine whether such measurements could be correlated with the two-phase momentum flux. The other  $\Delta P$  measurements provided backup and a check of self-consistency among these and the pressure measurements. K-factors for the drag screen, turbine, etc., are listed in Table VII. These were determined from all-water flows using the GfK values for  $\dot{m}_w$ .

### 3.2 Storz Lens

The Storz lens is a fine rod lens optical probe with lighting provided by an integral fiber optic. As a commercial device, its primary use has been in the medical field as a borescope. As a gross check of the feasibility of using such a device for two-phase flow regime measurements, the probe was inserted in the downstream flange of the scanning densitometer spool piece. A high intensity external light source was provided and the image was monitored by a small portable black and white video camera, as shown in Figure 8. Output from the camera was displayed in real time on a monitor and recorded on a video tape recorder. Two types of probes were used: one, having a 180 degree field of view looked across the flow but did not perturb it; the second, having a 90 degree field, intruded into the flow and could be adjusted to look either upstream or downstream at the circular flow cross section. Recordings of the flow pictures were obtained for eight air-water conditions and a few 4 bar steam-water conditions (21 December). Steam and water leakage and lens fogging precluded continued safe and useful operation of the commercial device under the steam-water conditions. The integral lighting was not really adequate for good resolution of the two-phase flows; however, gross features of the air-water flows are distinguishable on the video recordings. The unit did also play a significant role for in situ inspection of the drag screen and turbine rotor when problems were experienced with these instruments.

## IV. TEST MATRIX

Initial versions of the planned test matrix were based principally on the pressure and flow rate data in spool piece No. 15 from a typical 200% break flow Semiscale Mod-1 experiment. Subsequent revisions reflected such additional considerations as upstream disturbances, short piping lengths, and blowdown times of the order of 20 s. And of course the actual test matrix reflected the limitations of the test facility, and the choice between more runs of the easily accomplished type or fewer runs of the more unstable type.

Table VIII is the finally accomplished test matrix. The converging or diverging inlet parts of the test section did have a significant effect on the flow regimes observed in spite of the 65 diameter length between the area change and the spool piece. The flow regimes seemed much more distinct and more fully developed when the 80 to 66 mm converging inlet was used than the diverging case. Even so, a few distinct differences were observed between measured flow regimes

TABLE VII  
EQUIVALENT FRICTIONAL RESISTANCE K-FACTORS

<u>Device</u>	<u>K factor, Dimensionless<sup>a</sup></u>
Drag Screen (D-3)	0.258
Turbine (D-4)	0.780
Screen & Turbine (Direct) (D-5)	1.014
Screen & Turbine (Sum)	1.038
Pipe Friction (D-6)	0.226
Friction+Screen+Turbine (Direct)(D-7)	1.161
Friction+Screen+Turbine (Sum)	1.264

---

a.  $\Delta P, \text{ psid} = K \frac{\rho_u^2}{288 g_c}, \text{ psid}$

---

TABLE VIII  
TEST MATRIX AS PERFORMED

<u>Pressure, Bar</u>	<u>Superficial Water Velocity, m/s</u>	<u>Superficial Steam Velocity, m/s</u>
4	0.2	5, 10, 20, 40, 80
	0.5	5, 10, 20, 40, 60
	1.0	5, 10, 20, 44, 60
40	0.05	20
	0.10	2.5, 5, 10 <sup>2</sup> , 20 <sup>3b</sup>
	0.20	0.5 <sup>2</sup> , 1.0 <sup>2</sup> , 5 <sup>3</sup> , 10 <sup>3</sup> , 20 <sup>3</sup>
	0.50	0.5 <sup>3</sup> , 1.0 <sup>4</sup> , 2.5 <sup>4</sup> , 10 <sup>3</sup> , 20 <sup>2</sup>
	0.70	20
	1.0	0.5 <sup>2</sup> , 1.0 <sup>3</sup> , 2.5 <sup>4</sup> , 5 <sup>3</sup> , 10 <sup>3</sup>
75	0.2	1.0 <sup>2</sup> , 5 <sup>2</sup> , 10 <sup>2</sup> , 15 <sup>2</sup>
	0.5	0.5, 1.0 <sup>5</sup> , 2.5 <sup>3</sup> , 5 <sup>3</sup> , 10 <sup>2</sup> , 15 <sup>2</sup>
	0.7	1.0
	1.0	0.5, 1.0, 2.5, 5
	1.5	0.5, 0.7, 1.0, 2.5, 5

Test Condition Summary by Run Number

Pressure = 40bar

<u>Run</u>	<u>Date</u>	<u>Type of Drag Device</u>	<u>Type of Test Section Entrance</u>
2209-2231	5-7 Dec	Screen	Diverging (50 to 66 mm)
2249-2273	13, 14 Dec	Screen	Converging (80 to 66 mm)
2303-2319	19, 20 Dec	Disk	Converging

Pressure = 75bar

2233-2247	9 Dec	Screen	Diverging
2274-2283	14 Dec	Screen	Converging
2320-2336	20 Dec	Disk	Converging

Pressure = 4bar

2284-2302	15 Dec	Screen	Converging
2337-2340	21 Dec	Disk	Converging

- a. Conditions at spool piece  
b. Superscript indicates number of runs at that condition

and those expected on the basis of the Mandhane map. For this reason the test points have not been plotted on a map. However, in general the flow regimes observed were as indicated below.

<u>Pressure</u>	<u>Flow Regimes Observed</u>
4 bar	Slug, annular
40 bar	Elong. bubble, slug, stratified, wave, annular
75 bar	Elong. bubble, slug

#### V. SUMMARY OF TEST CONDITIONS AND RESULTS

Semiscale spool piece No. 15 (from the intact cold leg) was tested in the GfK steam-water facility at Karlsruhe, W. Germany. Separate, steady single phase steam and water flows were measured, mixed, and passed down an 8-m long, horizontal test section in which the instrumented spool piece was mounted. Time-averaged responses from the spool two-phase mass flow, inferential instruments (turbine, drag device, and densitometer) were measured and recorded for analysis and comparison with the single-phase measurements. Several other principal measurements of the flow were made, including the GfK radiotracer, impedance probe and few-beam densitometer, and the EG&G Idaho, Inc., scanning densitometer and Storz lens. Several auxiliary pressures, temperatures, and differential pressure measurements were also made. The appendices contain the tabulated data for subsequent analysis work.

The entire EG&G Idaho, Inc., computerized data acquisition system hardware and software were respectively procured and generated for this test work, as were also the scanning densitometer and Storz lens. The equipment and instrumentation were shipped to Germany, installed in the facility, and initially used in testing of two LOFT spool pieces. Subsequently, testing of the Semiscale spool piece was started and during a 15 calendar day span, data on 132 single- and two-phase test runs were obtained.

The nature of steady-flow testing imposed conditions on the instrumentation not found in normal Semiscale blowdown/reflood type experiments, and both instruments and measurements suffered somewhat: turbine bearings and drag screen pickup arm tips failed and densitometer beam readings drifted significantly during the much longer term, steady state testing regimes.

Test conditions included pressures of 0.4, 4.0, and 7.5 MPa, with two-phase flow rates of 0.5-5 kg/s and flow qualities of 1-83%. All flow regimes except dispersed bubble were observed in the 66.7 mm inside diameter test section. A spool piece adapting the mixer to the test section had an effect on flow regimes observed, depending on whether the flow was forced to converge from an 80 mm inside diameter to 66.7, or diverge from 50 to 66.7 mm.

## VI. REFERENCES

1. J. Reimann, H. John, E. Wanner, "Gemeinsamer Versuchsstand Zum Testen und Kalibrieren Verschiedener Zweiphasen - Massenstrom-messverfahren," PNS 1. Halbjahresbericht (1975) S. 180-187, KFK 2195
2. H. John, U. Muller, J. Reimann, "A Test Loop for Testing Measuring Methods for the Mass Flow Rate of Two-Phase Flows," GfK, IRB, paper presented at Specialists' Meeting on Transient Two-Phase Flow, OECD/Nuclear Energy Agency, Toronto, Canada, August 1976.
3. D. Barschdorff, G. Class, R. Loffel, J. Reimann, "Mass Flow Measuring Techniques in Transient Two Phase Flow," paper presented at Specialists' Meeting, op. cit.
4. Private communication, G. K. Maki, J. V. Gilbert, to A. G. Stephens "Real Time Data Acquisition System" (October 1977).
5. Fluid Meters, Their Theory and Application, 5th Edition, 1959, The American Society of Mechanical Engineers.
6. E. M. Feldman, S. A. Naff, Error Analysis for 1-1/2 Loop Semiscale System Isothermal Test Data, ANCR-1188, May 1975.
7. J. M. Beeston, "Investigation of Pin Failure in Semiscale Flow Drag Transducer," EG&G Idaho, Inc., Report LR-78-3-1, March 6, 1978.
8. G. P. Lilly, A. G. Stephens, L. E. Hochreiter, Mixing of Emergency Core Cooling Water with Steam: 1/14th Scale Testing Phase, Electric Power Research Institute (EPRI) Report 294-2, January 1975.

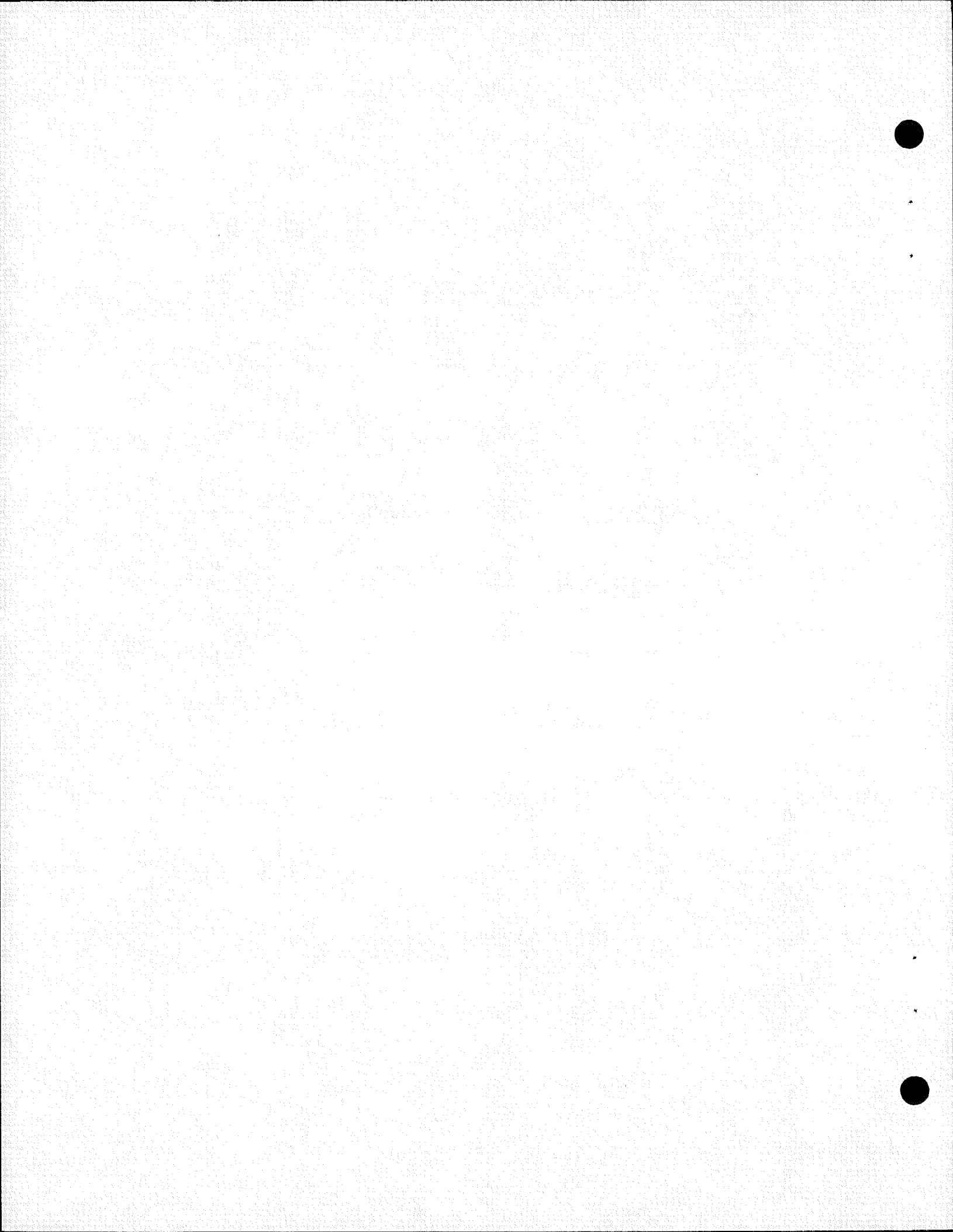

APPENDIX A

TABLES OF TEST CONDITIONS, PARAMETERS, AND MEASUREMENT  
DATA



## NOMENCLATURE

Table A-I Test Conditions as Measured by Institut für Reaktor  
Bauelement

Matrix Point $P$ , $C_w$ , $C_s$	-	Nominal values of pressure, superficial water velocity, and superficial steam velocity in the test section, respectively.
Measured Run Conditions	-	Facility (GfK/IRB) measurements
$P_{TS}$	-	absolute fluid pressure in the test section upstream of Semiscale spool piece
$T_{TS}$	-	fluid temperature in the test section upstream of Semiscale spool piece
$\dot{m}$	-	total mass flow rate
$X$	-	steam mass fraction at $P_{TS}$ , $T_{TS}$ - from energy balance
$C_w$	-	superficial water velocity, based on $\dot{m}$ , $X$ , $P_{TS}$ , $T_{TS}$
$C_s$	-	superficial steam velocity, based on $\dot{m}$ , $X$ , $P_{TS}$ , $T_{TS}$

Table A-II Principal Measurements

Semiscale Spool Piece Data - Principal EG&G Idaho, Inc., mass flow  
measurements on spool piece

$P_{SP}$	-	absolute fluid pressure at spool piece (listed as P4 in Table A-III)
$T_{SP}$	-	fluid temperature at spool piece (listed as T4 in Table A-III)

- Q - spool piece volumetric flow rate - full flow turbine meter signal
- $\rho_U, \rho_L$  - spool piece chordal average fluid density - upper and lower beam of dual beam densitometer
- $\rho_U^2$  - spool piece momentum flux - drag disk or full flow drag screen as noted

Other data - other principal EG&G Idaho, Inc., ( $\dot{m}$ ,  $\bar{\rho}$ ) and GfK/LIT) ( $u_w, u_s$ ) measurements, not on Semiscale spool piece

- $\dot{m}$  - sum of steam and water mass flow rates to the mixer
- $\bar{\rho}$  - cross sectional average fluid density - scanning densitometer
- $u_w$  - radiotracer liquid phase velocity
- $u_s$  - radiotracer vapor phase velocity

Table A-III Pressure and Temperature Data

- P1 - absolute steam pressure at steam flow orifice
- P3 - absolute fluid pressure at scanning densitometer
- P4 - absolute fluid pressure at Semiscale spool piece
- P5 - absolute fluid pressure just downstream of spool piece
- T1 - temperature at steam flow orifice
- T2 - temperature at water flow orifice

- T3 - fluid temperature at scanning densitometer
- T4 - fluid temperature at Semiscale spool piece
- T6 - metal temperature at Semiscale spool piece
- T9 - fluid temperature just downstream of spool piece

Table A-IV Differential Pressure Data

- DP1 - lower range steam orifice differential pressure
- DP2 - lower range water orifice differential pressure
- DP3 - drag screen (disk) pressure drop
- DP4 - turbine meter pressure drop
- DP5 - sum of drag device, turbine meter pressure drop
- DP6 - upstream frictional pressure drop
- DP7 - sum of frictional, drag device, turbine meter pressure drops
- DP10 - fixed impedance probe pressure drop
- DP11 - higher range steam orifice differential pressure
- DP12 - higher range water orifice differential pressure

Table A-V Miscellaneous Online - Calculated Parameters

Mixer Inlet -

- $V_s$  - superheated steam specific volume from P1, T1
- $H_s$  - superheated steam enthalpy from P1, T1
- $V_w$  - subcooled water specific volume from T2
- $H_s$  - subcooled water enthalpy from T2
- $\dot{m}_s$  - steam mass flow rate from DP1 (DP11),  $V_s$ , P1, T1
- $\dot{m}_w$  - water mass flow rate from DP2 (DP12),  $V_w$ , T2

#### Spool Piece

- $V_{s4}$  - specific volume of saturated steam in spool piece from P4
- $V_{w4}$  - specific volume of saturated water in spool piece from P4
- TS4 - saturation temperature in spool piece from P4
- UBAR - fluid velocity from turbine meter Q1

TABLE A-I

TEST CONDITIONS AS MEASURED BY INSTITUT FÜR REAKTOR BAUELEMENT

Run	Date	Matrix Point			Measured Run Conditions					
		P (MPa)	C <sub>w</sub> (m/s)	C <sub>s</sub> (m/s)	P <sub>TS</sub> (MPa)	T <sub>TS</sub> (°C)	C <sub>w</sub> (m/s)	C <sub>s</sub> (m/s)	ṁ (kg/s)	X (%)
2209	5 DEC	4.0	0.05	20.0	3.88	246	0.08	20.64	1.62	--
2210	5 DEC	4.0	0.70	20.0	4.05	251	0.12	19.89	1.75	--
2211	5 DEC	--	--	--	--	--	--	--	--	--
2212	5 DEC	--	--	--	--	--	--	--	--	--
2213	5 DEC	--	--	--	--	--	--	--	--	--
2215	6 DEC	4.0	1.0	0.0	4.10	225	1.11	0.00	2.89	0.0
2216	6 DEC	4.0	1.0	10.0	4.08	250	0.98	9.38	3.32	19.8
2217	6 DEC	4.0	1.0	5.0	4.13	252	0.97	5.12	3.05	12.2
2218	6 DEC	4.0	1.0	2.5	4.03	250	0.95	2.83	2.84	7.0
2219	6 DEC	4.0	1.0	1.0	4.03	251	0.94	0.99	2.69	2.6
2220	6 DEC	4.0	0.50	0.5	3.94	249	0.51	0.50	1.47	2.4
2221	6 DEC	4.0	0.50	1.0	4.01	250	0.51	1.28	1.52	5.9
2223	7 DEC	4.0	--	0.0	4.10	87	--	--	--	--
2224	7 DEC	4.0	0.50	10.0	4.04	249	0.49	9.89	2.06	34.0
2225	7 DEC	4.0	0.50	5.0	4.04	250	0.52	5.14	1.81	20.2
2226	7 DEC	4.0	0.20	5.0	4.08	252	0.20	5.93	0.97	43.9
2227A	7 DEC	4.0	0.20	0.5	4.05	251	0.17	0.60	0.53	8.1
2227B	7 DEC	4.0	0.20	0.5	4.05	251	0.17	0.60	0.53	8.1
2228	7 DEC	4.0	0.10	2.5	4.00	251	0.11	2.89	0.52	39.3
2229	7 DEC	4.0	0.10	10.0	4.03	250	0.13	10.17	1.07	67.3
2230	7 DEC	4.0	0.20	10.0	4.06	251	0.20	10.35	1.30	56.9
2231	7 DEC	4.0	1.0	2.5	4.09	250	1.05	2.42	3.11	5.6

TABLE A-I (continued)

Run	Date	Matrix Point			Measured Run Conditions					
		P (MPa)	C <sub>w</sub> (m/s)	C <sub>s</sub> (m/s)	P <sub>TS</sub> (MPa)	T <sub>TS</sub> (°C)	C <sub>w</sub> (m/s)	C <sub>s</sub> (m/s)	$\dot{m}$ (kg/s)	X (%)
2233	9 DEC	7.5	1.0	5.0	7.44	289	1.10	5.25	3.53	20.4
2234	9 DEC	7.5	1.0	2.5	7.50	289	1.07	2.68	3.12	11.9
2235	9 DEC	7.5	1.0	1.0	7.50	290	1.05	1.05	2.82	5.7
2236	9 DEC	7.5	1.0	0.5	7.50	290	1.08	0.44	2.83	2.2
2237	9 DEC	7.5	0.75	1.0	7.47	289	0.76	1.07	2.08	7.1
2238	9 DEC	7.5	0.5	0.5	7.43	288	0.54	0.51	1.44	4.9
2239	9 DEC	7.5	0.5	5.0	7.48	289	0.51	4.81	1.96	33.8
2240	9 DEC	7.5	0.5	2.5	7.45	289	0.54	2.51	1.73	20.0
2241	9 DEC	7.5	0.5	1.0	7.53	290	0.54	0.99	1.51	64.8
2242A	9 DEC	7.5	1.5	1.0	7.48	290	1.51	0.95	3.98	3.3
2242B	9 DEC	7.5	1.5	0.8	7.47	289	1.54	0.76	4.04	2.6
2243	9 DEC	7.5	1.5	0.50	7.44	289	1.54	0.59	4.02	2.0
2244	9 DEC	7.5	1.5	2.5	7.53	289	1.52	2.23	4.11	7.4
2245	9 DEC	7.5	1.5	5.0	7.48	289	1.39	4.97	4.23	16.2
2246	9 DEC	7.5	--	5.0	--	--	--	--	--	--
2247	9 DEC	7.5	1.5	--	--	--	--	--	--	--
2249	13 DEC	--	--	--	4.04	240	--	0.0	3.11	0.0
2250	13 DEC	--	--	--	4.03	240	--	0.0	1.67	0.0
2251	13 DEC	--	--	--	4.05	239	--	0.0	0.850	0.0
2252	13 DEC	4.0	1.0	5.0	3.97	248	1.03	5.25	3.24	11.3
2253	13 DEC	4.0	1.0	2.5	4.01	249	1.00	2.51	2.92	6.1
2254	13 DEC	4.0	1.0	0.5	3.96	248	1.01	0.40	2.87	1.0
2255	13 DEC	4.0	1.0	1.0	4.03	250	1.00	1.02	2.87	2.5
2256	13 DEC	4.0	1.0	10.0	4.02	249	1.02	9.64	3.51	19.4
2257	13 DEC	4.0	0.5	10.0	4.02	249	0.55	10.2	2.25	32.3
2258	13 DEC	4.0	0.5	5.0	3.96	249	0.51	5.41	1.80	21.0
2259	13 DEC	4.0	0.5	0.5	4.00	249	0.51	0.57	1.45	2.1
2260	13 DEC	4.0	0.5	1.0	4.01	248	0.53	0.98	1.55	4.5

TABLE A-I (continued)

Run	Date	Matrix Point			Measured Run Conditions					
		P (MPa)	C <sub>w</sub> (m/s)	C <sub>s</sub> (m/s)	P <sub>TS</sub> (MPa)	T <sub>TS</sub> (°C)	C <sub>w</sub> (m/s)	C <sub>s</sub> (m/s)	$\dot{m}$ (kg/s)	X (%)
2261	13 DEC	4.0	0.2	1.0	3.97	248	0.23	1.06	0.719	10.3
2262	13 DEC	4.0	0.2	5.0	3.95	248	0.24	5.22	1.02	35.4
2263	13 DEC	4.0	0.2	10.0	3.94	247	0.26	10.1	1.41	49.2
2264	13 DEC	--	--	--	--	--	--	--	--	--
2265	14 DEC	4.0	--	--	4.10	209	--	--	--	--
2266	14 DEC	4.0	0.5	20.0	3.97	250	0.51	19.5	2.80	49.0
2267	14 DEC	4.0	0.2	20.0	3.98	249	0.20	20.1	1.97	71.4
2268	14 DEC	4.0	0.1	20.0	4.01	250	0.21	19.8	1.72	80.9
2269	14 DEC	4.0	0.1	10.0	3.89	249	0.10	9.94	0.98	71.1
2270	14 DEC	4.0	0.1	20.0	3.97	249	0.11	19.4	1.70	82.1
2271	14 DEC	4.0	0.2	20.0	4.00	249	0.20	20.1	1.96	71.7
2272	14 DEC	4.0	0.1	5.00	4.06	250	0.10	5.11	0.64	56.9
2273	14 DEC	4.0	0.5	max	4.05	250	0.52	0.52	3.63	60.3
2274	14 DEC	7.5	0.5	max	7.48	289	0.49	15.9	3.45	63.9
2275	14 DEC	7.5	0.5	10.0	7.50	290	0.51	10.0	2.70	51.4
2276	14 DEC	7.5	0.5	5.00	7.48	290	0.53	5.11	2.06	34.3
2277	14 DEC	7.5	0.5	1.0	7.56	290	0.55	1.07	1.56	9.6
2278	14 DEC	7.5	0.5	2.5	7.49	290	0.55	3.04	1.82	23.2
2279	14 DEC	7.5	0.2	10.0	7.45	290	0.21	10.7	2.02	72.8
2280	14 DEC	7.5	0.2	5.0	7.53	291	0.24	4.74	1.28	51.5
2281	14 DEC	7.5	0.2	1.0	7.49	292	0.26	1.44	0.85	23.4
2282	14 DEC	7.5	0.2	max	7.57	290	0.32	15.8	3.01	73.9
2283	14 DEC	7.5	--	--	--	--	--	--	--	--
2284	15 DEC	--	--	--	--	--	--	--	--	--
2285	15 DEC	0.40	1.0	max	0.410	143	1.03	43.4	3.64	9.2
2286	15 DEC	0.40	1.0	5	0.440	160	1.05	4.14	3.40	1.0
2287	15 DEC	0.40	1.0	10	0.408	147	1.03	12.9	3.40	2.9

TABLE A-I (continued)

Run	Date	Matrix Point			Measured Run Conditions					
		P (MPa)	C <sub>w</sub> (m/s)	C <sub>s</sub> (m/s)	P <sub>TS</sub> (MPa)	T <sub>TS</sub> (°C)	C <sub>w</sub> (m/s)	C <sub>s</sub> (m/s)	ṁ (kg/s)	X (%)
2288	15 DEC	0.40	1.0	20	0.408	147	1.01	20.8	3.40	4.7
2289	15 DEC	0.40	0.5	40	0.416	146	0.50	41.3	1.95	16.6
2290	15 DEC	0.40	0.5	20	0.440	150	0.50	21.2	1.76	9.9
2291	15 DEC	0.40	0.5	10	0.392	147	0.53	11.8	1.81	4.8
2292	15 DEC	0.40	0.5	5	0.448	152	0.475	3.09	1.55	1.7
2293	15 DEC	0.40	0.2	5	0.456	151	0.281	4.13	0.938	3.8
2294	15 DEC	0.40	0.2	20	0.480	154	0.153	18.3	0.654	25.1
2295	15 DEC	0.40	0.2	10	0.472	152	0.115	9.23	0.449	18.2
2296	15 DEC	0.40	0.2	40	0.432	149	0.219	42.2	1.05	32.7
2297	15 DEC	0.40	0.0	30	0.432	166	--	31.7	0.247	104
2298	15 DEC	0.40	0.0	60	0.440	172	--	59.0	0.468	104
2299	15 DEC	0.40	0.2	max	0.472	144	0.191	78.8	1.31	93.2
2300	15 DEC	0.40	0.5	max	0.545	148	0.497	65.0	2.24	29.3
2301	15 DEC	0.40	1.0	max	0.601	150	1.00	57.5	3.75	15.2
2302	15 DEC	0.40	max	0.0	0.440	135	1.12	--	3.51	2.3
2303	19 DEC	4.0	1.0	10.0	3.97	250	1.10	10.15	3.77	18.8
2304	19 DEC	4.0	1.0	5.0	3.96	250	1.02	4.82	3.19	10.5
2305	19 DEC	4.0	1.0	2.5	3.97	250	1.01	2.57	2.99	6.0
2306	19 DEC	4.0	1.0	1.0	4.00	250	1.01	0.91	2.88	2.2
2307	19 DEC	4.0	max	0.0	3.99	233	1.28	0.0	--	--
2308	19 DEC	4.0	1.0	0.5	3.96	249	0.98	0.80	2.81	2.0
2309	19 DEC	4.0	0.5	10.0	3.98	251	0.49	10.46	2.11	34.7
2310A	19 DEC	4.0	0.5	5.0	3.95	250	0.51	5.14	1.73	19.9
2310B	19 DEC	4.0	0.5	5.0	--	--	--	--	--	--
2311	19 DEC	4.0	0.5	2.5	3.95	249	0.52	2.80	1.64	11.8
2312A	19 DEC	4.0	0.5	1.0	4.02	250	0.52	0.82	1.50	3.9
2312B	19 DEC	4.0	0.5	1.0	--	--	--	--	--	--
2313A	19 DEC	4.0	0.5	0.5	--	--	--	--	--	--

TABLE A-I (continued)

Run	Date	Matrix Point			Measured Run Conditions					
		P (MPa)	C <sub>w</sub> (m/s)	C <sub>s</sub> (m/s)	P <sub>TS</sub> (MPa)	T <sub>TS</sub> (°C)	C <sub>w</sub> (m/s)	C <sub>s</sub> (m/s)	m (kg/s)	X (%)
2313	20 DEC	4.0	max	0.0	3.99	212	1.94	--	4.91	10.7
2314	20 DEC	4.0	0.5	20	4.01	251	0.50	21.2	2.90	51.6
2315	20 DEC	4.0	0.2	20	4.01	251	0.20	19.0	1.90	79.6
2316	20 DEC	4.0	0.2	10	3.93	251	0.22	9.94	1.31	52.3
2317	20 DEC	4.0	0.1	20	3.97	250	0.10	19.7	1.65	83.4
2318	20 DEC	4.0	0.20	5.0	3.94	249	0.20	5.29	0.94	39.0
2319	20 DEC	4.0	0.20	1.0	3.99	253	0.21	1.00	0.66	10.7
2320	20 DEC	4.0	--	--	--	--	--	--	--	--
2321	20 DEC	4.0	--	--	--	--	--	--	--	--
2322	20 DEC	7.5	0.50	14.0	7.48	289	0.52	13.8	3.24	58.9
2323	20 DEC	7.5	0.50	10.0	7.43	290	0.51	10.8	2.79	52.9
2324	20 DEC	7.5	0.50	5.0	7.47	289	0.53	5.15	2.09	34.0
2325	20 DEC	7.5	0.50	2.5	7.45	290	0.55	2.24	1.7-	18.1
2326	20 DEC	7.5	0.50	1.0	7.52	289	0.56	1.11	1.59	9.70
2327	20 DEC	7.5	0.20	1.0	7.54	293	0.20	0.81	0.62	18.2
2328	20 DEC	7.5	0.20	5.0	7.48	290	0.21	4.99	1.21	56.8
2329	20 DEC	7.5	0.20	10.0	7.49	289	0.21	10.1	1.93	72.0
2330	20 DEC	7.5	0.20	15.0	7.51	291	0.21	15.0	2.61	79.4
2331	20 DEC	7.5	--	max	7.48	318	--	--	--	--
2332	20 DEC	7.5	--	max	7.46	321	--	10.4	1.30	1.10
2333	20 DEC	7.5	--	max	7.52	318	--	5.50	0.69	1.10
2335	20 DEC	7.5	0.50	1.0	7.45	289	0.52	0.91	1.44	8.70
2336	20 DEC	7.5	0.50	1.0	7.42	289	--	--	--	--
2337	21 DEC	--	--	--	--	--	--	--	--	--
2338	21 DEC	--	--	--	--	--	--	--	--	--
2339	21 DEC	--	--	--	--	--	--	--	--	--
2340	21 DEC	--	--	--	--	--	--	--	--	--

TABLE A-II  
PRINCIPAL MEASUREMENTS

Run	Semiscale Spool Piece Data						Other Data	
	P <sub>SP</sub> (MPa)	T <sub>SP</sub> (°C)	Q (m <sup>3</sup> /s) x10 <sup>-3</sup>	ρ <sub>U</sub> (kg/m <sup>3</sup> )	ρ <sub>L</sub> (kg/m <sup>3</sup> )	ρ <sub>u</sub> <sup>2</sup> (kg/ms <sup>2</sup> )	m̄ (kg/s)	ρ̄ (kg/m <sup>3</sup> )
2209	--	251	34.4	0.93	52.7	88.8	1.64	--
2210	--	253	33.0	1.78	54.6	305	1.76	--
2211	--	253	60.9	7.91	51.2	3260	2.79	21.9
2212	--	252	62.1	2.13	48.4	3210	2.63	20.1
2213	--	253	60.9	19.3	62.7	6030	3.19	23.7
2215	--	254	20.9	27.7	199.0	2060	3.44	824
2216	--	254	21.0	21.5	195.2	2100	3.44	--
2217	--	254	11.4	25.1	301.0	791	3.08	--
2218	--	253	6.8	33.9	390.0	510	2.89	--
2219	--	253	7.4	133.0	509.0	289	2.74	--
2220	--	252	5.0	205.0	555.0	160	1.48	--
2221	--	253	6.1	78.2	422.0	81	1.53	--
2223	4.15	90	1.3	957.0	977.0	1710	3.30	965
2224	4.15	253	22.4	--	150.0	2330	2.08	112
2225	4.15	253	2.8	--	247.0	2330	1.82	--
2226	4.17	254	2.7	--	168.0	2190	0.988	115
2227A	4.15	253	--	85.8	534.0	950	0.581	406
2227B	4.14	253	--	29.5	493.0	1780	0.536	--
2228	4.10	253	--	--	212.0	1960	0.523	149
2229	4.12	253	8.1	--	101.0	1920	1.09	67.1
2230	4.15	253	8.4	--	106.0	1940	1.31	76.5
2231	4.15	253	4.8	4.6	378.0	1850	3.19	289

TABLE A-II (continued)

Run	Semiscale Spool Piece Data						Other Data	
	$P_{SP}$ (MPa)	$T_{SP}$ (°C)	$Q$ (m <sup>3</sup> /s) $\times 10^{-3}$	$\rho_U$ (kg/m <sup>3</sup> )	$\rho_L$ (kg/m <sup>3</sup> )	$\rho_U^2$ (kg/ms <sup>2</sup> )	$\dot{m}$ (kg/s)	$\bar{\rho}$ (kg/m <sup>3</sup> )
2233	7.44	289	30.1	-46.5	253.0	--	3.56	230
2234	7.64	292	10.2	-13.2	350.0	915	3.15	328
2235	7.64	292	6.52	66.7	445.0	610	2.88	433
2236	7.64	292	1.22	184.0	519.0	555	2.87	506
2237	7.61	292	5.40	16.5	440.0	420	2.12	387
2238	7.56	291	3.18	129.0	514.0	275	1.45	--
2239	7.60	292	14.1	--	226.0	913	1.97	180
2240	7.65	292	7.69	--	303.0	479	1.72	258
2241	7.67	292	4.18	31.8	425.0	334	1.52	365
2242A	7.58	291	7.85	198.0	529.0	1100	4.06	525
2242B	7.58	291	7.30	267.0	575.0	1070	4.08	--
2243	7.56	291	6.96	314.0	620.0	1020	4.07	586
2244	7.61	291	11.4	61.6	424.0	1690	4.29	378
2245	7.60	291	17.3	14.3	295.0	2590	4.29	262
2246	7.56	292	22.7	--	29.6	821	0.788	34.1
2247	7.65	280	4.62	717.0	755.0	736	3.49	753
2249	4.12	241	0.056	833	829	1020	3.11	--
2250	4.10	241	0.056	844	821	372	1.67	--
2251	4.12	240	0.056	840	831	115	0.850	--
2252	4.05	252	15.0	50.1	309	4750	3.28	--
2253	4.07	252	9.19	70.1	397	2710	3.03	--
2254	4.02	251	5.40	237.0	575	362	2.88	--
2255	4.08	252	6.13	157	526	404	2.91	--
2256	4.07	252	26.3	28.7	238	1830	3.55	--
2257	4.08	252	27.4	0	192	1160	2.26	--
2258	4.03	252	13.9	3	255	484	1.79	--

TABLE A-II (continued)

Run	Semiscale Spool Piece Data						Other Data	
	$P_{SP}$ (MPa)	$T_{SP}$ (°C)	$Q$ (m <sup>3</sup> /s) $\times 10^{-3}$	$\rho_U$ (kg/m <sup>3</sup> )	$\rho_L$ (kg/m <sup>3</sup> )	$\rho_U^2$ (kg/ms <sup>2</sup> )	$\dot{m}$ (kg/s)	$\bar{\rho}$ (kg/m <sup>3</sup> )
2259	4.05	251	3.62	84.6	485	178	1.48	--
2260	4.07	252	4.23	67.8	443	215	1.57	--
2261	4.02	251	2.90	12.8	444	106	0.726	--
2262	3.99	251	13.6	--	204	294	1.03	--
2263	3.99	251	27.7	--	157	782	1.42	--
2264	4.10	234	0.00	822	867	0.00	0.00	--
2265	4.05	208 <sup>a</sup>	1.67	868	861	119	1.45	--
2266	4.00	250 <sup>a</sup>	--	--	82.3	4140	2.82	65.2
2267	4.01	250 <sup>a</sup>	--	--	40.9	5380	2.01	36.8
2268	4.03	250 <sup>a</sup>	--	4.82	36.5	4430	1.78	31.3
2269	4.01	250 <sup>a</sup>	28.0	8.81	104	1020	1.02	53.3
2270	3.98	250 <sup>a</sup>	65.4	32.4	57.1	4380	1.84	--
2271	3.98	250 <sup>a</sup>	64.3	44.9	60.3	5350	2.00	--
2272	4.04	254 <sup>a</sup>	12.2	9.54	177	317	0.673	--
2273	4.03	250 <sup>a</sup>	102.0	23.1	51.9	18800	3.66	3.54
2274	7.56	289 <sup>a</sup>	53.6	21.9	92.3	7920	3.49	71.2
2275	7.56	290 <sup>a</sup>	30.2	26.7	155.0	2870	2.72	113
2276	7.53	290 <sup>a</sup>	14.3	11.3	266	918	2.04	193
2277	7.62	287 <sup>a</sup>	4.12	53.0	469	274	1.56	368
2278	7.56	289 <sup>a</sup>	8.58	--	332	508	1.81	238
2279	7.49	289 <sup>a</sup>	33.1	10.8	129	2290	2.03	140

TABLE A-II (continued)

Run	Semiscale Spool Piece Data						Other Data	
	$P_{SP}$ (MPa)	$T_{SP}$ (°C)	$Q$ (m <sup>3</sup> /s) $\times 10^{-3}$	$\rho_U$ (kg/m <sup>3</sup> )	$\rho_L$ (kg/m <sup>3</sup> )	$\rho_U^2$ (kg/ms <sup>2</sup> )	$\dot{m}$ (kg/s)	$\bar{\rho}$ (kg/m <sup>3</sup> )
2280	7.60	290 <sup>a</sup>	4.46	23.5	208.0	590	1.29	--
2281	7.52	290 <sup>a</sup>	2.45	22.1	380.0	164	0.860	--
2282	7.56	290 <sup>a</sup>	60.8	22.4	97.8	7370	3.35	--
2283	7.62	273 <sup>a</sup>	0.84	778	788	190	1.35	--
2284	0.444	139	3.81	933	937	503	3.59	927
2285	0.353	150	51.2	--	96.0	18100	3.70	--
2286	0.393	154	8.57	68.2	512	999	3.47	--
2287	0.351	151	12.0	9.3	277	2640	3.46	--
2288	0.356	151	10.7	--	280	3480	3.46	216
2289	0.365	152	20.3	--	60.8	11000	1.97	59.6
2290	0.386	154	5.85	--	194	2010	1.78	137
2291	0.343	150	4.71	--	249	961	1.83	167
2292	0.396	154	3.88	--	379	437	1.57	239
2293	0.324	148	3.90	51.4	349	518	1.21	194
2294	0.424	156	3.80	40.3	176	775	0.657	82.3
2295	0.371	152	3.68	21.9	282	398	0.801	149
2296	0.379	153	10.0	33.0	98.7	6800	1.07	39.2
2297	0.375	153	5.08	23.0	59.3	1020	0.248	2.52
2298	0.391	161	76.3	15.8	59.4	3340	0.472	2.56
2299	0.408	154	96.2	14.1	60.8	26400	1.39	--
2300	0.477	159	93.2	18.3	58.8	35900	2.32	13.3
2301	0.533	163	98.8	22.0	105	26400 <sup>b</sup>	3.87	53.2
2302	0.387	138	0.30	990	997	520 <sup>b</sup>	3.58	924

TABLE A-II (continued)

Run	Semiscale Spool Piece Data						Other Data	
	$P_{SP}$ (MPa)	$T_{SP}$ (°C)	$Q$ (m <sup>3</sup> /s) $\times 10^{-3}$	$\rho_U$ (kg/m <sup>3</sup> )	$\rho_L$ (kg/m <sup>3</sup> )	$\rho_U^2$ (kg/ms <sup>2</sup> )	$\dot{m}$ (kg/s)	$\bar{\rho}$ (kg/m <sup>3</sup> )
2303	3.99	252	27.3	13.1	223	4220	3.81	--
2304	3.99	252	14.0	29.1	348	1290	3.22	261
2305	4.00	252	9.24	58.4	447	1190	3.03	439
2306	4.02	252	6.43	111	533	798	2.93	--
2307	4.01	235	4.45	827	829	661	3.69	823
2308	4.04	251	5.50	160	579	631	2.81	--
2309	4.00	252	27.8	4.20	170	2220	2.12	--
2310A	3.99	252	13.1	4.96	265	373	1.78	--
2310B	4.01	252	12.8	4.65	268	342	1.76	--
2311	4.01	252	8.13	8.45	346	63	1.64	--
2312A	3.98	251	4.11	46.2	481	-66	1.53	369
2312B	4.06	252	4.23	43.9	476	-51	1.51	--
2313A	4.00	218	--	--	--	0.26	--	--
2313B	4.04	214	5.68	855	846	1610	4.99	848
2314	4.03	252	6.52	3.23	52.4	11600	2.93	51.2
2315	4.04	253	60.3	3.22	27.3	7080	1.92	--
2316	3.97	252	26.7	3.23	124	1770	1.31	--
2317	3.93	251	53.3	3.21	583	5750	1.81	--
2318	3.97	252	12.3	3.23	189	379	0.944	--
2319	4.01	252	2.58	3.79	437	95.3	0.670	--
2320	7.60	225	1.58	859	850	189	1.29	--
2321	7.58	229	1.60	861	852	202	1.29	--
2322	7.59	292	44.6	6.90	83.5	8310	3.27	--
2323	7.52	291	34.9	3.78	106	5330	2.87	116

74

TABLE A-II (continued)

Run	Semiscale Spool Piece Data						Other Data	
	$P_{SP}$ (MPa)	$T_{SP}$ (°C)	$Q$ (m <sup>3</sup> /s) $\times 10^{-3}$	$\rho_U$ (kg/m <sup>3</sup> )	$\rho_L$ (kg/m <sup>3</sup> )	$\rho_U^2$ (kg/ms <sup>2</sup> )	$\dot{m}$ (kg/s)	$\bar{p}$ (kg/m <sup>3</sup> )
2324	7.60	292	14.8	3.33	240	1050	2.09	196
2325	7.53	291	7.34	7.36	340	374	1.72	300
2326	7.60	291	4.9	32.5	418	309	1.60	--
2327	7.62	292	2.60	4.26	430	-83.8	0.667	336
2328	7.57	292	14.9	3.66	158	836	1.26	133
2329	7.58	292	31.5	3.26	106	3260	1.95	44.1
2330	7.56	291	51.0	4.88	43.7	7840	2.64	--
2331	7.56	316	55.6	3.30	41.6	6000	1.96	34.5
2332	7.48	316	37.5	4.19	29.8	2700	1.30	--
2333	7.59	316	18.8	3.46	42.1	500	0.658	--
2335	7.53	291	4.3	32.8	469	192	1.46	--
2336	7.53	291	4.8	20.0	448	262	1.57	374
2337	0.324	147 <sup>a</sup>	--	65.5	308	2720	4.09	--
2338	0.462	158 <sup>a</sup>	--	56.5	339	3140	3.56	--
2339	0.438	156 <sup>a</sup>	--	194	508	3080	3.46	--
2340	0.375	152 <sup>a</sup>	--	39.2	259	2690	1.82	--

- a. Amplifier gain on T-4 measurement set improperly. The data acquisition mode of time-averaging the temperature in engineering units, rather than the corresponding voltage, precludes proper correction because of the non-linear relation between voltage and temperature. Best estimate of T-4, obtained by interpolation between T-3 and T-9, is given.
- b. One of the pins connecting a force transducer to the drag screen failed. Momentum values listed are not correct.

TABLE A-III

## PRESSURE AND TEMPERATURE DATA

Run	Absolute Pressures				Temperatures					
	P1 (MPa)	P3 (MPa)	P4 (MPa)	P5 (MPa)	T1 (°C)	T2 (°C)	T3 (°C)	T4 (°C)	T6 (°C)	T9 (°C)
Full Scale										
2209	4.58	3.97	--	4.02	279	237	251	251	249	249
2210	4.71	4.11	--	4.16	280	232	253	253	251	251
2211	5.78	4.07	--	4.12	303	246	252	253	251	251
2212	5.76	4.04	--	4.09	302	243	252	252	250	250
2213	5.81	4.08	--	4.12	301	250	252	253	251	251
2215	4.51	4.13	--	4.16	275	226	254	254	252	252
2216	4.51	4.12	--	4.14	275	224	253	254	252	252
2217	4.31	4.13	--	4.16	274	225	254	254	252	252
2218	4.13	4.06	--	4.09	272	236	253	253	251	251
2219	4.09	4.06	--	4.10	268	240	252	253	251	251
2220	4.00	3.99	--	4.03	264	240	249	252	250	248
2221	4.06	4.04	--	4.08	264	238	252	253	250	250
2223	4.14	3.93	4.15	4.09	57	102	90	90	90	90
2224	4.41	3.89	4.15	4.04	290	227	253	253	251	251
2225	4.20	3.88	4.15	4.04	291	230	253	253	251	251
2226	4.22	3.90	4.17	4.07	299	233	253	254	251	251
2227A	4.10	3.89	4.15	4.06	280	234	251	253	251	248
2227B	4.09	3.88	4.14	4.05	275	232	252	253	251	248
2228	4.07	3.83	4.10	4.00	288	230	252	253	250	250
2229	4.33	3.85	4.12	4.01	303	233	252	253	251	251
2230	4.39	3.89	4.15	4.05	305	235	253	253	251	251
2231	4.17	3.89	4.15	4.05	296	238	253	253	251	251

TABLE A-III (continued)

Run	Absolute Pressures				Temperatures					
	P1 (MPa)	P3 (MPa)	P4 (MPa)	P5 (MPa)	T1 (°C)	T2 (°C)	T3 (°C)	T4 (°C)	T6 (°C)	T9 (°C)
Full Scale										
2233	7.75	7.43	7.60	7.55	352	268	290	291	289	289
2234	7.67	7.48	7.64	7.60	345	267	290	292	289	289
2235	7.61	7.47	7.64	7.60	336	266	290	292	289	289
2236	7.59	7.47	7.64	7.60	337	266	289	292	289	289
2237	7.56	7.44	7.61	7.57	344	266	290	292	289	288
2238	7.49	7.39	7.56	7.52	333	266	287	291	288	285
2239	7.68	7.44	7.60	7.57	339	267	290	292	289	289
2240	7.62	7.48	7.65	7.61	330	267	290	292	289	289
2241	7.61	7.50	7.67	7.64	325	266	290	292	289	288
2242A	7.57	7.42	7.58	7.55	327	267	290	291	289	288
2242B	7.56	7.41	7.58	7.54	330	265	289	291	289	288
2243	7.53	7.39	7.56	7.52	326	265	289	291	288	287
2244	7.65	7.44	7.61	7.57	327	266	290	292	289	289
2245	7.72	7.43	7.60	7.56	326	278	290	291	289	289
2246	7.66	7.39	7.56	7.53	323	268	315	292	306	311
2247	7.27	7.48	7.65	7.62	289	281	279	280	277	277
2249	4.02	4.04	4.12	4.10	213	243	240	241	239	239
2250	4.00	4.03	4.10	4.09	217	244	240	241	238	239
2251	4.03	4.05	4.12	4.10	216	243	239	240	237	238
2252	5.84	3.99	4.05	4.05	311	237	250	252	249	249
2253	4.60	4.02	4.07	4.08	307	238	251	252	250	249
2254	4.09	3.96	4.02	4.03	289	237	247	251	248	243
2255	4.24	4.02	4.08	4.09	290	238	250	252	250	246
2256	4.30	4.01	4.07	4.07	289	237	251	252	250	250
2257	4.30	4.02	4.08	4.08	289	236	251	252	250	250
2258	4.06	3.97	4.03	4.04	274	235	250	252	249	249

TABLE A-III (continued)

Run	Absolute Pressures				Temperatures					
	P1 (MPa)	P3 (MPa)	P4 (MPa)	P5 (MPa)	T1 (°C)	T2 (°C)	T3 (°C)	T4 (°C)	T6 (°C)	T9 (°C)
Full Scale										
2259	4.15	3.99	4.05	4.05	256	231	249	251	249	242
2260	4.25	4.01	4.07	4.08	263	231	250	252	250	244
2261	4.09	3.96	4.02	4.03	258	230	249	251	249	244
2262	4.64	3.94	3.99	4.00	267	230	250	251	249	249
2263	6.79	3.93	3.99	3.99	287	232	249	251	249	249
2264	4.02	4.04	4.10	4.11	251	235	229	234	227	227
2265	3.96	4.05	4.05	4.05	182	213	209	208 <sup>a</sup>	207	208
2266	4.61	4.00	4.00	3.99	295	217	251	250 <sup>a</sup>	250	250
2267	4.59	4.01	4.01	4.00	295	215	251	250 <sup>a</sup>	250	250
2268	4.58	4.03	4.03	4.02	296	214	251	250 <sup>a</sup>	250	250
2269	4.11	4.01	4.01	4.00	294	218	251	250 <sup>a</sup>	250	250
2270	4.53	3.99	3.98	3.97	297	217	250	250 <sup>a</sup>	--	250
2271	4.55	3.98	3.98	3.97	295	219	250	250 <sup>a</sup>	--	249
2272	4.01	4.04	4.04	4.04	292	218	259	254 <sup>a</sup>	--	250
2273	5.38	4.04	4.03	4.01	295	221	251	250 <sup>a</sup>	--	250
2274	8.21	7.58	7.56	7.54	331	273	290	289 <sup>a</sup>	--	289
2275	7.76	7.45	7.56	7.49	330	272	290	290 <sup>a</sup>	--	289
2276	7.49	7.43	7.53	7.47	327	278	290	290 <sup>a</sup>	--	289

TABLE A-III (continued)

Run	Absolute Pressures				Temperatures					
	P1 (MPa)	P3 (MPa)	P4 (MPa)	P5 (MPa)	T1 (°C)	T2 (°C)	T3 (°C)	T4 (°C)	T6 (°C)	T9 (°C)
Full Scale										
2277	7.48	7.51	7.62	7.56	322	276	290	287 <sup>a</sup>	288	284
2278	7.46	7.45	7.56	7.50	322	277	290	289 <sup>a</sup>	288	288
2279	7.71	7.39	7.49	7.44	332	275	290	289 <sup>a</sup>	289	288
2280	7.54	7.50	7.60	7.54	328	276	290	290 <sup>a</sup>	289	289
2281	7.39	7.42	7.52	7.46	321	276	292	290 <sup>a</sup>	288	288
2282	8.18	7.46	7.56	7.47	332	279	290	290 <sup>a</sup>	289	289
2283	7.46	7.51	7.62	7.56	314	278	274	273 <sup>a</sup>	271	273
2284	0.503	0.443	0.444	0.447	134	140	139	139	138	138
2285	0.917	0.350	0.353	0.295	260	139	150	150	150	145
2286	0.547	0.391	0.393	0.392	197	136	153	154	153	152
2287	0.565	0.348	0.352	0.342	179	135	150	151	150	149
2288	0.660	0.353	0.356	0.338	190	134	150	151	150	148
2289	0.875	0.362	0.365	0.336	194	136	151	152	151	148
2290	0.631	0.384	0.386	0.379	191	139	153	154	153	152
2291	0.483	0.339	0.343	0.339	177	135	149	150	149	148
2292	0.494	0.392	0.396	0.397	173	136	153	154	153	151
2293	0.419	0.319	0.324	0.322	164	137	148	148	147	146
2294	0.612	0.421	0.424	0.424	179	138	156	156	155	155
2295	0.486	0.367	0.371	0.371	180	139	152	152	152	151
2296	0.854	0.377	0.379	0.360	205	140	152	153	152	150
2297	0.680	0.371	0.375	0.372	191	130	170	153	157	164
2298	1.090	0.388	0.391	0.376	203	122	177	161	165	173

TABLE A-III (continued)

Run	Absolute Pressures				Temperatures					
	P1 (MPa)	P3 (MPa)	P4 (MPa)	P5 (MPa)	T1 (°C)	T2 (°C)	T3 (°C)	T4 (°C)	T6 (°C)	T9 (°C)
Full Scale										
2299	1.79	0.408	0.408	0.298	219	138	154	154	154	144
2300	1.81	0.480	0.477	0.348	210	139	159	159	159	149
2301	1.83	0.538	0.533	0.390	210	139	163	163	163	152
2302	0.701	0.386	0.387	0.390	169	139	137	138	136	136
2303	4.68	3.99	3.99	3.99	321	235	251	252	250	250
2304	4.56	4.00	3.99	4.01	310	231	251	252	250	250
2305	4.66	4.01	4.00	4.01	308	233	251	252	250	249
2306	4.31	4.03	4.02	4.04	301	234	250	252	250	247
2307	4.02	4.02	4.01	4.03	244	237	234	235	233	233
2308	4.18	4.04	4.04	4.05	297	238	249	251	250	245
2309	5.67	4.01	4.00	4.01	335	237	251	252	250	250
2310A	4.44	3.99	3.99	4.00	319	236	251	252	250	250
2310B	4.46	4.02	4.01	4.03	314	236	251	252	250	251
2311	4.71	4.02	4.01	4.03	312	237	251	252	250	250
2312A	4.15	3.99	3.98	4.00	302	235	249	251	249	244
2312B	4.24	4.06	4.06	4.08	298	236	251	252	250	246
2313A	--	4.01	4.00	4.02	--	--	217	218	216	217
2313B	--	4.05	4.04	4.06	217 <sup>b</sup>	213	214	214	213	213
2314	4.78	4.04	4.03	4.04	300	228	251	252	251	251
2315	4.59	4.04	4.04	4.05	300	232	251	253	251	251
2316	4.10	3.98	3.97	3.99	297	238	251	252	250	250
2317	4.39	3.94	3.93	3.95	296	234	250	251	250	249

TABLE A-III (continued)

Run	Absolute Pressures				Temperatures					
	P1 (MPa)	P3 (MPa)	P4 (MPa)	P5 (MPa)	T1 (°C)	T2 (°C)	T3 (°C)	T4 (°C)	T6 (°C)	T9 (°C)
Full Scale										
2318	3.98	3.98	3.97	3.99	292	230	251	252	250	250
2319	4.13	4.01	4.01	4.03	281	220	251	252	250	243
2320	7.46	7.49	7.60	7.56	235	228	223	225	221	222
2321	7.44	7.46	7.58	7.54	227	232	228	229	225	226
2322	8.17	7.48	7.59	7.54	333	246	290	292	289	290
2323	7.85	7.41	7.52	7.47	332	262	290	291	289	289
2324	7.60	7.48	7.60	7.56	330	263	290	292	289	290
2325	7.45	7.42	7.53	7.50	329	260	290	291	288	288
2326	7.49	7.48	7.60	7.56	325	259	290	291	289	283
2327	7.51	7.51	7.62	7.58	321	254	290	292	289	281
2328	7.55	7.46	7.57	7.54	330	257	290	292	289	289
2329	7.80	7.46	7.58	7.53	334	266	290	292	289	289
2330	8.12	7.45	7.56	7.51	334	271	290	291	289	289
2331	8.12	7.45	7.56	7.52	332	286	316	316	315	316
2332	7.69	7.37	7.48	7.44	331	273	316	316	314	316
2333	7.56	7.47	7.59	7.55	330	265	316	316	308	316
2335	7.49	7.41	7.53	7.49	323	271	289	291	288	283
2336	7.52	7.42	7.53	7.49	324	270	289	291	288	284
2337	0.486 <sup>b</sup>	0.336	0.324	0.348	152 <sup>b</sup>	150	--	147 <sup>a</sup>	147	147
2338	0.629	0.478	0.462	0.493	205	149	--	158 <sup>a</sup>	159	158
2339	0.534	0.453	0.438	0.471	188	152	--	156 <sup>a</sup>	157	156
2340	0.554	0.389	0.375	0.404	203	151	--	152 <sup>a</sup>	152	152

a. Amplifier gain on T-4 measurement set improperly. The data acquisition mode of time-averaging the temperature, in engineering units, rather than the corresponding voltage, precludes proper correction because of the non-linear relation between voltage, and temperature. Best estimate of T-4, obtained by interpolation between T-3 and T-9, is given.

b. Two-phase condition in test section for this run achieved by mixing and throttling two water streams, not mixing steam and water streams. P-1, T-1, DP-1, DP-11,  $V_S$ ,  $H_S$ ,  $\dot{m}_S$  are second water stream measurements to mixing chamber.

TABLE A-IV  
DIFFERENTIAL PRESSURE DATA

Run	DP1 (kPa)	DP2 (kPa)	DP3 (kPa)	DP4 (kPa)	DP5 (kPa)	DP6 (kPa)	DP7 (kPa)	DP10 (kPa)	DP11 (kPa)	DP12 (kPa)
Full Scale										
2209	31.6	3.38	1.33	4.34	5.84	0.59	5.44	1.54	48.2	1.92
2210	31.6	6.23	1.43	4.71	6.40	0.59	5.85	1.51	48.0	4.81
2211	31.7	8.28	3.63	11.5	15.5	2.02	15.5	4.04	118.0	6.89
2212	31.7	2.70	3.14	10.1	13.6	1.93	13.7	3.74	120.0	1.25
2213	31.7	31.1	5.04	14.3	19.7	2.21	19.7	4.45	119.0	30.2
2215	31.1	58.3	0.74	16.9	19.7	0.17	18.2	0.12	120.0	0.0
2216	31.1	58.1	0.75	16.8	19.7	0.18	18.2	0.11	121.0	0.0
2217	31.2	55.9	0.13	9.82	9.95	0.07	9.00	-0.13	51.9	0.0
2218	18.2	58.8	0.04	6.69	6.70	0.01	5.91	-0.25	17.1	0.0
2219	4.7	59.6	-0.08	3.60	3.48	-0.10	2.79	-0.27	3.48	0.0
2220	1.12	17.5	-0.13	1.06	0.91	-0.10	0.36	-0.21	0.00	0.0
2221	3.95	17.1	-0.13	1.47	1.32	-0.09	0.76	-0.21	2.73	0.0
2223	3.87	83.3	0.00	4.25	4.35	0.24	3.82	0.15	2.68	0.0
2224	31.1	15.4	0.25	11.8	12.3	0.10	11.0	0.16	101.0	0.0
2225	31.2	17.1	0.09	5.26	5.56	-0.10	4.48	-0.02	33.7	0.0
2226	31.2	2.78	0.02	3.45	3.67	-0.14	2.65	0.05	34.7	0.0
2227A	0.66	2.41	-0.11	0.28	0.39	-0.18	-0.47	-0.04	0.00	0.0
2227B	0.88	1.92	-0.11	0.26	0.36	-0.18	-0.50	-0.04	0.00	0.0
2228	8.49	0.86	-0.10	0.82	0.92	-0.20	-0.004	-0.04	7.68	0.0
2229	31.3	1.41	0.27	7.60	8.04	-0.09	6.76	0.13	89.6	0.0
2230	31.3	3.17	0.31	8.72	9.19	-0.07	7.86	0.12	94.4	0.0
2231	18.2	73.9	0.04	7.19	7.40	-0.06	6.19	-0.23	17.6	0.0

TABLE A-IV (continued)

Run	DP1 (kPa)	DP2 (kPa)	DP3 (kPa)	DP4 (kPa)	DP5 (kPa)	DP6 (kPa)	DP7 (kPa)	DP10 (kPa)	DP11 (kPa)	DP12 (kPa)
Full Scale										
2233	31.1	70.9	0.39	3.52	3.85	-0.08	3.23	0.09	72.9	0.0
2234	31.2	64.3	0.14	1.79	1.81	-0.13	1.28	-0.19	30.4	0.0
2235	12.8	59.8	0.02	0.82	0.67	-0.19	0.19	-0.27	11.8	0.0
2236	8.74	62.8	-0.04	3.26	3.02	-0.20	2.40	0.27	7.72	0.0
2237	9.07	31.4	-0.04	0.52	0.24	-0.19	-0.18	-0.25	8.07	0.0
2238	2.88	15.4	-0.08	0.16	-0.14	-0.19	-0.51	-0.23	1.92	0.0
2239	31.3	15.4	0.12	1.75	1.62	-0.13	1.20	-0.08	49.8	0.0
2240	17.9	15.9	-0.06	0.73	0.39	-0.17	0.04	-0.19	17.1	0.0
2241	5.69	15.4	-0.10	0.24	-0.16	-0.19	-0.48	-0.24	4.75	0.0
2242A	17.7	125.0	0.02	1.32	0.96	-0.14	0.66	-0.31	16.9	0.0
2242B	17.5	126.0	0.02	1.14	0.78	-0.15	0.49	-0.32	16.6	0.0
2243	15.2	127.0	0.02	1.02	0.66	-0.15	0.38	-0.32	14.4	0.0
2244	31.4	126.0	0.16	2.47	2.25	-0.02	2.00	-0.19	38.3	0.0
2245	31.4	118.0	0.40	4.24	4.26	0.01	3.93	0.10	61.6	0.0
2246	31.4	0.0	-0.01	0.37	-0.02	-0.37	-0.42	-0.60	61.5	0.0
2247	0.0	118.0	-0.04	0.31	-0.11	-0.11	-0.25	-0.11	0.0	0.0
2249	0.0	86.9	0.05	2.41	2.38	-0.08	1.84	0.03	0.0	0.0
2250	0.0	25.0	-0.02	0.67	0.58	0.14	0.14	-0.05	0.0	0.0
2251	0.0	6.50	-0.05	0.19	0.06	0.15	0.40	0.10	0.0	0.0
2252	28.7	71.0	0.34	3.61	3.75	0.06	3.32	0.45	27.8	0.0
2253	13.2	67.8	0.07	1.64	1.48	0.01	1.15	0.07	12.1	0.0
2254	3.21	67.6	-0.04	0.63	0.31	-0.06	0.01	0.01	2.06	0.0
2255	5.45	66.7	-0.03	0.80	0.46	-0.03	0.19	-0.01	4.30	0.0
2256	31.3	69.4	0.94	7.58	8.17	0.37	7.79	1.14	104.0	0.0
2257	31.4	20.3	0.54	5.14	5.34	0.18	4.97	0.76	103.0	0.0
2258	31.4	16.6	0.09	2.05	1.81	-0.06	1.43	0.15	32.5	0.0

TABLE A-IV (continued)

Run	DP1 (kPa)	DP2 (kPa)	DP3 (kPa)	DP4 (kPa)	DP5 (kPa)	DP6 (kPa)	DP7 (kPa)	DP10 (kPa)	DP11 (kPa)	DP12 (kPa)
Full Scale										
2259	2.54	16.3	-0.14	0.24	-0.23	-0.11	-0.55	-0.13	1.61	0.0
2260	3.75	17.7	-0.14	0.32	-0.17	-0.11	-0.47	-0.07	2.83	0.0
2261	2.04	3.34	-0.19	0.13	-0.42	-0.13	-0.71	-0.16	1.14	0.0
2262	24.4	3.55	-0.10	1.14	0.66	-0.12	0.33	-0.02	23.9	0.0
2263	31.4	4.04	0.25	3.06	2.92	0.02	2.57	0.42	54.7	0.0
2264	0.0	116.0	-0.18	-0.06	-0.60	-0.14	-0.89	-0.19	0.0	0.0
2265	0.0	31.0	-0.03	0.05	-0.04	-0.11	-0.48	-0.08	0.48	97.7
2266	31.6	31.1	2.05	9.75	11.7	0.66	11.2	1.82	53.5	92.4
2267	31.7	18.2	1.50	6.00	7.36	0.59	7.11	1.75	51.4	17.0
2268	31.8	8.30	1.26	4.84	5.95	0.53	5.74	1.62	49.2	7.02
2269	13.4	5.73	0.21	1.87	1.90	-0.12	1.35	0.30	13.9	4.49
2270	31.8	7.62	1.23	4.75	5.76	0.54	5.59	1.61	49.1	6.37
2271	31.8	18.5	1.47	5.97	7.21	0.59	7.00	1.73	50.7	17.3
2272	3.56	5.18	-0.04	0.57	0.28	-0.21	-0.23	-0.05	4.06	3.90
2273	31.8	31.4	5.72	16.0	21.5	1.81	21.5	4.14	109.0	97.3
2274	31.9	31.5	2.06	7.70	9.39	0.65	9.10	2.24	66.6	95.3
2275	27.8	31.5	0.713	4.60	4.92	0.132	4.44	1.11	29.0	95.2
2276	7.61	31.5	0.10	1.92	1.62	-0.08	1.16	0.54	8.43	96.3
2277	0.66	31.5	-0.12	0.37	-0.15	-0.15	0.56	0.26	1.50	96.1
2278	3.21	31.5	-0.05	1.01	0.56	-0.13	0.12	0.35	4.03	96.6
2279	28.7	23.9	0.47	3.23	3.31	0.10	2.92	1.00	29.9	22.5
2280	6.63	23.1	-0.01	3.81	3.40	-0.17	2.74	0.41	7.44	21.8
2281	0.72	23.2	-0.13	0.69	0.18	-0.19	-0.29	0.23	1.53	21.9
2282	31.8	31.5	1.96	17.1	40.3	0.59	37.9	2.19	64.4	83.1
2283	0.0	31.5	-0.10	0.45	-0.06	-0.18	-0.49	0.25	0.80	95.3

TABLE A-IV (continued)

Run	DP1 (kPa)	DP2 (kPa)	DP3 (kPa)	DP4 (kPa)	DP5 (kPa)	DP6 (kPa)	DP7 (kPa)	DP10 (kPa)	DP11 (kPa)	DP12 (kPa)
Full Scale										
2284	0.0	102	0.08	0.46	0.25	0.03	0.15	0.06	0.00	0.0
2285	31.2	88.5	4.03	17.1	56.3	1.03	51.9	1.88	118	0.0
2286	21.8	88.0	0.03	3.92	3.23	-0.02	3.25	0.07	21.7	0.0
2287	31.3	84.9	0.41	9.43	9.83	0.27	9.67	1.45	38.2	0.0
2288	31.3	81.7	1.05	15.4	17.6	0.72	17.3	0.91	62.8	0.0
2289	31.4	20.6	2.48	17.1	29.8	0.67	28.6	1.28	109	0.0
2290	31.4	19.6	0.62	9.34	9.31	0.35	9.19	0.57	48.3	0.0
2291	20.8	22.9	0.14	4.08	3.67	0.18	3.70	0.34	20.6	0.0
2292	7.45	17.6	-0.09	1.28	0.645	0.02	0.71	-0.03	7.02	0.0
2293	6.65	10.2	-0.05	1.53	0.96	0.04	1.02	0.08	6.21	0.0
2294	31.3	1.82	0.16	3.57	3.18	0.02	3.08	0.23	36.1	0.0
2295	12.8	4.05	-0.03	1.65	1.10	0.02	1.13	0.03	12.4	0.0
2296	31.4	4.12	1.66	17.1	21.3	0.72	20.8	1.37	109.0	0.0
2297	31.4	0.0	0.04	4.65	4.04	-0.09	3.85	0.04	68.5	0.0
2298	31.4	0.0	0.74	16.4	16.4	0.32	15.8	-0.46	160.0	0.0
2299	31.4	3.14	7.85	17.1	105	2.48	52.1	4.36	246.0	0.0
2300	31.4	19.1	10.5	20.1	118	2.54	95.6	5.64	245.0	0.0
2301	31.4	75.7	11.4	20.2	118	3.24	95.8	6.73	246.0	0.0
2302	0.0	101	0.10	2.24	-0.73	0.05	1.76	0.03	0.0	0.0
2303	31.0	81.9	1.44	7.92	10.56	0.37	8.69	1.14	109.0	0.0
2304	31.0	67.2	0.43	3.27	4.87	0.09	3.13	0.24	37.8	0.0
2305	15.5	66.0	0.44	1.60	3.18	0.00	1.49	-0.01	14.9	0.0
2306	7.38	66.1	0.25	0.65	2.01	-0.02	0.41	-0.13	6.80	0.0
2307	0.0	121.0	0.05	0.44	1.57	-0.04	0.00	-0.11	0.0	0.0
2308	3.55	63.8	0.15	0.45	1.64	-0.05	0.09	-0.14	2.97	0.0
2309	31.1	17.6	0.62	4.81	6.41	0.15	4.77	0.53	76.4	0.0

TABLE A-IV (continued)

Run	DP1 (kPa)	DP2 (kPa)	DP3 (kPa)	DP4 (kPa)	DP5 (kPa)	DP6 (kPa)	DP7 (kPa)	DP10 (kPa)	DP11 (kPa)	DP12 (kPa)
Full Scale										
2310A	26.6	17.6	-0.02	1.88	2.83	-0.05	1.25	-0.05	26.3	0.0
2310B	26.2	17.1	-0.05	1.81	2.74	-0.05	1.16	-0.07	25.8	0.0
2311	11.1	17.2	-0.13	0.93	1.76	-0.06	0.25	-0.19	10.5	0.0
2312A	2.89	17.5	-0.13	0.26	1.06	-0.12	-0.45	-0.30	2.25	0.0
2312B	3.12	17.1	-0.12	0.28	1.07	-0.14	-0.43	-0.28	2.47	0.0
2313A	0.01	--	-0.20	-0.01	0.71	-0.03	-0.69	-0.27	0.03	--
2313B	108 <sup>a</sup>	30.8	0.37	0.85	1.18	0.06	0.94	0.17	0.0 <sup>a</sup>	96.8
2314	31.5	31.0	4.15	8.73	12.7	0.88	12.6	2.08	57.6	98.6
2315	31.6	20.5	2.17	4.70	6.71	0.51	6.60	1.46	44.7	19.1
2316	13.0	22.5	0.40	2.62	2.85	-0.03	2.49	0.34	13.5	21.1
2317	28.8	23.4	--	4.42	5.96	0.39	5.81	1.17	37.1	22.0
2318	3.75	17.0	-0.03	0.86	0.64	-0.15	0.31	-0.08	4.25	15.7
2319	0.38	14.5	-0.14	0.09	-0.26	-0.13	-0.49	-0.20	0.96	13.1
2320	0.0	31.2	-0.34	0.07	0.56	0.07	-0.62	0.23	0.63	80.4
2321	0.0	31.2	-0.06	0.03	-0.08	-0.05	-0.46	-0.13	0.63	80.1
2322	31.6	31.2	2.63	5.62	8.14	0.67	7.95	1.35	56.2	86.1
2323	31.6	31.2	1.75	4.65	6.21	0.26	5.81	0.84	36.5	89.9
2324	9.23	31.2	0.33	1.88	2.00	-0.03	1.58	0.13	9.91	89.8
2325	2.85	31.3	0.10	0.68	0.53	-0.07	0.19	-0.14	3.52	85.9
2326	1.27	31.3	0.10	0.26	0.10	-0.12	-0.25	-0.17	1.96	88.5
2327	0.43	12.5	-0.04	0.06	-0.25	-0.14	-0.61	-0.23	1.13	10.8
2328	7.79	16.1	0.189	1.00	0.91	-0.12	0.50	-0.04	8.47	14.3
2329	26.4	22.0	0.854	2.73	3.31	0.20	3.04	0.46	27.4	20.3
2330	31.7	26.7	2.40	3.98	6.10	0.54	5.99	1.35	56.4	25.0
2331	31.7	0.0	1.53	2.60	3.84	0.18	3.52	0.19	56.6	0.0
2332	25.7	0.0	0.62	1.17	1.49	-0.23	0.93	-0.50	26.7	0.0

TABLE A-IV (continued)

Run	DP1 (kPa)	DP2 (kPa)	DP3 (kPa)	DP4 (kPa)	DP5 (kPa)	DP6 (kPa)	DP7 (kPa)	DP10 (kPa)	DP11 (kPa)	DP12 (kPa)
Full Scale										
2333	6.97	0.0	0.08	0.25	0.01	-0.43	-0.63	-0.88	7.68	0.0
2335	0.74	31.4	0.06	0.21	-0.03	-0.12	-0.39	-0.25	1.49	79.4
2336	0.93	31.4	0.09	0.26	0.04	-0.12	0.32	-0.23	1.69	91.2
2337	20.5 <sup>a</sup>	93.0	1.07	2.35	3.19	1.03	3.69	-0.17	21.3 <sup>a</sup>	--
2338	23.5	92.8	0.73	1.55	2.01	0.39	2.02	-0.17	24.0	--
2339	3.05	93.1	0.66	-0.16	0.21	0.06	0.04	-0.18	3.22	--
2340	28.2	22.4	0.52	1.01	1.23	0.30	1.23	-0.18	28.5	--

a. Two-phase condition in test section for this run achieved by mixing and throttling two water streams, not mixing steam and water streams. P-1, T-1, DP-1, DP-11,  $V_s$ ,  $H_s$ ,  $\dot{m}_s$  are second water stream measurements to mixing chamber.

TABLE A-V

## MISCELLANEOUS ON-LINE-CALCULATED PARAMETERS

Run	Mixer Inlet						Spool Piece			
	$V_s$ ( $m^3/kg$ ) $\times 10^{-3}$	$H_s$ (J/g) $\times 10^3$	$V_w$ ( $m^3/kg$ ) $\times 10^{-3}$	$H_w$ (J/g) $\times 10^3$	$\dot{m}_s$ (kg/s)	$\dot{m}_w$ (kg/s)	$V_{s4}$ ( $m^3/kg$ ) $\times 10^{-3}$	$V_{w4}$ ( $m^3/kg$ ) $\times 10^{-3}$	$T_{s4}$ ( $^{\circ}C$ )	UBAR (m/s)
2209	47.0	2.88	1.22	1.03	1.38	0.264	--	1.25	--	9.85
2210	45.5	2.87	1.21	1.00	1.40	0.360	--	1.26	--	9.47
2211	38.3	2.90	1.24	1.07	2.38	0.411	--	1.26	--	17.4
2212	38.3	2.90	1.24	1.05	2.40	0.235	--	1.26	--	17.8
2213	37.8	2.90	1.25	1.09	2.41	0.781	--	1.26	--	17.5
2215	47.2	2.86	1.20	0.973	0.854	2.58	--	1.26	--	6.00
2216	47.3	2.86	1.20	0.965	0.856	2.58	--	1.26	--	6.02
2217	49.8	2.87	1.20	0.966	0.549	2.53	--	1.26	--	3.27
2218	51.9	2.87	1.22	1.02	0.315	2.57	--	1.26	--	2.12
2219	51.9	2.86	1.23	1.04	0.162	2.58	--	1.26	--	2.12
2220	52.5	2.85	1.23	1.04	0.0783	1.40	--	1.26	--	1.44
2221	51.4	2.85	1.22	1.03	0.149	1.38	--	1.26	--	1.75
2223	--	--	1.04	0.427	0.00	3.30	--	1.04	253	0.36
2224	51.0	2.92	1.20	0.979	0.756	1.33	48.0	1.26	253	6.43
2225	54.3	2.93	1.21	0.991	0.425	1.39	48.1	1.26	252	0.80
2226	55.3	2.95	1.21	1.00	0.427	0.560	47.9	1.26	253	0.77
2227A	53.8	2.90	1.22	1.01	0.0597	0.522	48.0	1.26	253	--
2227B	53.1	2.88	1.21	0.999	0.0693	0.466	48.2	1.26	252	--
2228	55.7	2.92	1.21	0.992	0.211	0.313	48.7	1.26	252	--
2229	54.1	2.96	1.21	1.00	0.691	0.399	48.5	1.26	252	2.33
2230	53.7	2.96	1.21	1.01	0.712	0.598	48.0	1.26	253	2.41
2231	55.6	2.95	1.22	1.03	0.307	2.88	48.0	1.26	253	1.39

TABLE A-V (continued)

Run	Mixer Inlet						Spool Piece			
	$V_s$ ( $m^3/kg$ ) $\times 10^{-3}$	$H_s$ (J/g) $\times 10^3$	$V_w$ ( $m^3/kg$ ) $\times 10^{-3}$	$H_w$ (J/g) $\times 10^3$	$\dot{m}_s$ (kg/s)	$\dot{m}_w$ (kg/s)	$V_{s4}$ ( $m^3/kg$ ) $\times 10^{-3}$	$V_{w4}$ ( $m^3/kg$ ) $\times 10^{-3}$	$T_{s4}$ ( $^{\circ}C$ )	UBAR (m/s)
2233	31.4	3.00	1.30	1.18	0.822	2.74	24.9	1.37	291	4.80
2234	31.1	2.98	1.29	1.17	0.534	2.62	24.8	1.37	292	2.93
2235	30.5	2.96	1.29	1.17	0.351	2.52	24.8	1.37	292	1.86
2236	30.7	2.96	1.29	1.16	0.289	2.59	24.8	1.37	292	0.35
2237	31.5	2.98	1.29	1.16	0.290	1.83	24.9	1.37	291	1.54
2238	30.8	2.95	1.29	1.17	0.165	1.28	25.1	1.37	291	0.91
2239	30.5	2.96	1.29	1.17	0.690	1.28	24.9	1.37	291	4.06
2240	29.7	2.93	1.29	1.17	0.419	1.30	24.8	1.37	292	2.20
2241	29.2	2.91	1.29	1.17	0.238	1.28	24.7	1.37	292	1.19
2242A	29.7	2.92	1.29	1.17	0.417	3.64	25.0	1.37	291	2.24
2242B	30.1	2.94	1.29	1.16	0.412	3.67	25.0	1.37	291	2.09
2243	29.8	2.92	1.29	1.16	0.386	3.68	25.1	1.37	291	1.99
2244	29.2	2.92	1.29	1.16	0.617	3.67	24.9	1.37	291	3.25
2245	28.8	2.91	1.33	1.23	0.789	3.50	24.9	1.37	291	4.97
2246	28.8	2.90	--	--	0.788	0.00	25.2	--	291	6.51
2247	--	--	1.34	1.24	0.0	3.49	--	1.33	292	1.32
2249	--	--	1.24	1.06	0.0	3.11	--	1.23	252	0.02
2250	--	--	1.24	1.06	0.0	1.67	--	1.23	252	0.02
2251	--	--	1.24	1.05	0.0	0.850	--	1.23	252	0.02
2252	38.8	2.93	1.22	1.02	0.457	2.82	49.3	1.25	251	4.31
2253	51.0	2.96	1.23	1.03	0.275	2.76	48.9	1.26	251	2.64
2254	55.6	2.93	1.22	1.02	0.130	2.76	49.5	1.25	251	1.54
2255	53.5	2.93	1.22	1.03	0.172	2.74	48.8	1.26	251	1.76
2256	52.4	2.92	1.22	1.02	0.755	2.79	49.0	1.26	251	7.54
2257	52.3	2.92	1.22	1.02	0.753	1.51	48.9	1.26	251	7.85
2258	53.3	2.88	1.22	1.01	0.420	1.37	49.6	1.25	251	3.99

TABLE A-V (continued)

Run	Mixer Inlet						Spool Piece			
	$V_s$ ( $m^3/kg$ ) $\times 10^{-3}$	$H_s$ (J/g) $\times 10^3$	$V_w$ ( $m^3/kg$ ) $\times 10^{-3}$	$H_w$ (J/g) $\times 10^3$	$\dot{m}_s$ (kg/s)	$\dot{m}_w$ (kg/s)	$V_{s4}$ ( $m^3/kg$ ) $\times 10^{-3}$	$V_{w4}$ ( $m^3/kg$ ) $\times 10^{-3}$	$T_{s4}$ ( $^{\circ}C$ )	UBAR (m/s)
2259	48.6	2.81	1.21	0.996	0.123	1.36	49.2	1.25	251	1.04
2260	48.5	2.83	1.21	0.996	0.150	1.42	49.0	1.25	251	1.20
2261	49.9	2.82	1.21	0.990	0.109	0.617	49.6	1.25	251	0.83
2262	44.1	2.83	1.21	0.990	0.397	0.635	50.0	1.25	250	3.91
2263	28.7	2.79	1.21	1.000	0.744	0.676	50.1	1.25	250	7.94
2264	49.5	2.80	1.21	1.01	0.0	0.0	44.4	1.25	252	0.0
2265	--	--	1.18	0.913	0.0	1.45	--	1.17 <sup>a</sup>	251	0.48
2266	49.2	2.93	1.18	0.929	1.42	1.40	50.0 <sup>a</sup>	1.25 <sup>a</sup>	250	--
2267	49.5	2.93	1.18	0.921	1.39	0.624	50.0 <sup>a</sup>	1.25 <sup>a</sup>	251	--
2268	49.7	2.93	1.18	0.915	1.36	0.422	50.0 <sup>a</sup>	1.25 <sup>a</sup>	251	--
2269	56.1	2.94	1.18	0.936	0.667	0.350	50.0 <sup>a</sup>	1.25 <sup>a</sup>	250	8.02
2270	50.4	2.93	1.18	0.932	1.34	0.493	50.0 <sup>a</sup>	1.25 <sup>a</sup>	250	18.7
2271	50.0	2.93	1.19	0.938	1.37	0.628	50.0 <sup>a</sup>	1.25 <sup>a</sup>	250	18.4
2272	57.3	2.94	1.19	0.935	0.340	0.332	46.7 <sup>a</sup>	1.26 <sup>a</sup>	251	3.49
2273	40.8	2.90	1.19	0.948	2.22	1.44	50.0 <sup>a</sup>	1.25 <sup>a</sup>	251	29.2
2274	27.2	2.92	1.31	1.20	2.14	1.36	26.0	1.36	291	15.4
2275	29.0	2.93	1.31	1.20	1.37	1.36	25.5	1.36	291	8.64
2276	30.1	2.93	1.32	1.23	0.687	1.36	25.5	1.36	291	4.08
2277	29.6	2.91	1.32	1.22	0.202	1.36	26.8	1.36	292	1.18
2278	29.7	2.91	1.32	1.22	0.446	1.36	26.0	1.36	291	2.46
2279	29.6	2.94	1.32	1.21	1.37	0.659	26.0	1.36	290	9.48
2280	29.9	2.93	1.32	1.22	0.644	0.646	25.5	1.36	291	1.28
2281	30.0	2.91	1.32	1.22	0.212	0.648	25.5	1.36	291	0.70
2282	27.3	2.92	1.33	1.23	2.09	1.26	25.5	1.36	291	17.4
2283	28.8	2.88	1.33	1.23	0.0	1.35	--	1.31	292	0.24

TABLE A-V (continued)

Run	Mixer Inlet						Spool Piece			
	$V_s$ ( $\frac{m^3}{kg}$ ) $\times 10^{-3}$	$H_s$ (J/g) $\times 10^3$	$V_w$ ( $\frac{m^3}{kg}$ ) $\times 10^{-3}$	$H_w$ (J/g) $\times 10^3$	$\dot{m}_s$ (kg/s)	$\dot{m}_w$ (kg/s)	$V_{s4}$ ( $\frac{m^3}{kg}$ ) $\times 10^{-3}$	$V_{w4}$ ( $\frac{m^3}{kg}$ ) $\times 10^{-3}$	$T_{s4}$ ( $^{\circ}C$ )	UBAR (m/s)
2284	--	--	1.08	5.89	0.0	3.59	409	1.08	147	1.09
2285	261	2.97	1.08	0.587	0.348	3.35	537	1.09	139	14.7
2286	385	2.85	1.08	0.570	0.126	3.35	485	1.10	143	2.45
2287	355	2.81	1.08	0.570	0.173	3.29	540	1.09	139	3.43
2288	311	2.83	1.07	0.563	0.235	3.23	533	1.09	139	3.08
2289	234	2.82	1.08	0.572	0.353	1.62	521	1.09	140	5.81
2290	327	2.83	1.08	0.587	0.202	1.58	494	1.09	142	1.67
2291	416	2.81	1.08	0.580	0.118	1.71	552	1.09	138	1.35
2292	402	2.80	1.08	0.572	0.073	1.50	482	1.10	143	1.11
2293	465	2.78	1.08	0.574	0.064	1.14	584	1.09	136	1.12
2294	327	2.80	1.08	0.580	0.176	0.481	451	1.10	146	1.09
2295	417	2.81	1.08	0.585	0.094	0.708	513	1.09	141	1.05
2296	247	2.85	1.08	0.588	0.343	0.723	501	1.09	142	2.88
2297	302	2.83	1.07	0.546	0.248	0.0	508	1.09	141	1.46
2298	190	2.83	1.06	0.512	0.472	0.0	497	1.10	143	21.8
2299	115	2.83	1.08	0.582	0.754	0.631	467	1.10	144	27.6
2300	111	2.80	1.08	0.584	0.769	1.56	402	1.10	150	26.7
2301	110	2.80	1.08	0.584	0.772	3.10	362	1.11	154	28.3
2302	276	2.78	1.08	0.584	0.000	3.58	470	1.08	142	0.09
2303	52.1	3.0	1.22	1.01	0.76	3.04	50.3	1.26	250	7.81
2304	52.1	2.97	1.22	0.995	0.459	2.76	50.2	1.26	250	4.02
2305	50.5	2.96	1.21	1.01	0.299	2.73	50.2	1.26	250	2.65
2306	54.1	2.96	1.22	1.01	0.200	2.73	49.7	1.26	251	1.84
2307	48.0	2.77	1.22	1.02	0.0	3.69	46.0	1.22	251	1.27
2308	55.5	2.95	1.23	1.03	0.137	2.67	49.4	1.26	251	1.58

TABLE A-V (continued)

Run	Mixer Inlet						Spool Piece			
	$V_s$ ( $m^3/kg$ ) $\times 10^{-3}$	$H_s$ (J/g) $\times 10^3$	$V_w$ ( $m^3/kg$ ) $\times 10^{-3}$	$H_w$ (J/g) $\times 10^3$	$\dot{m}_s$ (kg/s)	$\dot{m}_w$ (kg/s)	$V_{s4}$ ( $m^3/kg$ ) $\times 10^{-3}$	$V_{w4}$ ( $m^3/kg$ ) $\times 10^{-3}$	$T_{s4}$ ( $^{\circ}C$ )	UBAR (m/s)
2309	43.4	3.01	1.22	1.02	0.715	1.41	50.1	1.26	250	7.97
2310A	55.0	3.00	1.22	1.02	0.373	1.41	50.3	1.26	250	3.77
2310B	54.1	2.99	1.22	1.02	0.373	1.39	49.9	1.26	251	3.66
2311	50.5	2.97	1.22	1.02	0.254	1.39	50.0	1.26	251	2.33
2312A	56.7	2.96	1.22	1.01	0.122	1.40	50.3	1.26	250	1.18
2312B	54.9	2.95	1.22	1.02	0.129	1.39	49.3	1.26	251	1.22
2313A	--	2.90	--	--	--	--	40.7	1.19	250	--
2313B	1.19 <sup>b</sup>	0.931 <sup>b</sup>	1.18	0.910	3.55 <sup>b</sup>	1.44	38.0	1.18	251	1.63
2314	47.8	2.93	1.21	0.983	1.49	1.44	49.7	1.26	251	18.7
2315	50.2	2.94	1.21	1.00	1.29	0.634	49.7	1.26	251	17.3
2316	56.7	2.95	1.23	1.03	0.654	0.660	50.5	1.26	250	7.65
2317	52.7	2.94	1.23	1.01	1.14	0.675	51.1	1.26	249	15.3
2318	57.9	2.94	1.21	0.993	0.347	0.597	50.5	1.26	250	3.51
2319	53.6	2.90	1.19	0.946	0.115	0.555	50.0	1.26	250	0.74
2320	--	--	1.20	0.981	0.000	1.29	--	1.20	291	0.45
2321	--	--	1.20	1.00	0.000	1.29	--	1.20	291	0.45
2322	27.5	2.93	1.24	1.07	1.95	1.32	25.0	1.37	291	12.8
2323	28.9	2.93	1.28	1.14	1.54	1.33	25.3	1.37	291	10.0
2324	29.8	2.93	1.28	1.15	0.760	1.33	25.0	1.37	291	4.24
2325	30.5	2.93	1.27	1.13	0.418	1.31	25.2	1.37	291	2.10
2326	29.9	2.92	1.27	1.13	0.276	1.33	24.9	1.37	291	1.34
2327	29.4	2.90	1.26	1.11	0.165	0.502	24.9	1.37	292	0.74
2328	30.1	2.94	1.27	1.12	0.695	0.567	25.1	1.37	291	4.27
2329	29.3	2.94	1.29	1.16	1.32	0.632	25.1	1.37	291	9.01
2330	27.8	2.93	1.31	1.19	1.94	0.697	25.1	1.37	291	14.6

TABLE A-V (continued)

Run	Mixer Inlet						Spool Piece			
	$V_s$ ( $m^3/kg$ ) $\times 10^{-3}$	$H_s$ (J/g) $\times 10^3$	$V_w$ ( $m^3/kg$ ) $\times 10^{-3}$	$H_w$ (J/g) $\times 10^3$	$\dot{m}_s$ (kg/s)	$\dot{m}_w$ (kg/s)	$V_{s4}$ ( $m^3/kg$ ) $\times 10^{-3}$	$V_{w4}$ ( $m^3/kg$ ) $\times 10^{-3}$	$T_{s4}$ ( $^{\circ}C$ )	UBAR (m/s)
2331	27.6	2.92	--	--	1.96	0.0	28.4	--	291	15.9
2332	29.6	2.93	--	--	1.30	0.0	28.9	--	290	10.7
2333	30.0	2.93	--	--	0.658	0.0	28.3	--	291	5.38
2335	29.6	2.91	1.30	1.19	0.216	1.24	25.2	1.37	291	1.24
2336	29.7	2.92	1.30	1.19	0.243	1.33	25.2	1.37	291	1.37
2337	1.09 <sup>b</sup>	0.640 <sup>b</sup>	1.09	0.631	0.672 <sup>b</sup>	3.42	424	1.09	136	--
2338	339	2.86	1.09	0.627	0.142	3.42	322	1.10	149	--
2339	386	2.83	1.09	0.641	0.048	3.42	338	1.10	147	--
2340	385	2.86	1.09	0.636	0.144	1.68	373	1.09	141	--

- a. Amplifier gain on T-4 measurement set improperly. The data acquisition mode of time-averaging the temperature, in engineering units, rather than corresponding voltage, precludes proper correction because of the non-linear relation between voltage and temperature. Best estimate of T-4, obtained by interpolation between T-3 and T-9, is given.
- b. Two-phase condition in test section for this run achieved by mixing and throttling two water streams, not mixing steam and water streams. P-1, T-1, DP-1, DP-11,  $V_s$ ,  $H_s$ ,  $\dot{m}_s$  are second water stream measurements to mixing chamber.



^

.

^

.



APPENDIX B

DATA REDUCTION EQUATIONS



7

7



## APPENDIX B

### GDATA

The essential function of GDATA is to fetch a digital signal from the ADC, convert to proper set of English units, and execute a series of PSEUDO (P-channel) calculations. The first option executed in GDATA is the number of ADC (channels are 16 per card) that are being utilized. A maximum of 48 channels (3 cards) are utilized in GDATA; 1 to 3 cards can be active at any one time. The system operates faster if a minimum number of cards are activated, since fewer subroutine calls to fetch the digital words have to be executed. The equations used in GDATA are found in this Appendix. GDATA inputs all ADC channels, but only those that are activated are converted to proper units, and only those P-channels that are activated are executed. The output data from GDATA is in proper English units. Material in this appendix is abstracted from Reference 4.

APPENDIX B

EQUATIONS USED TO GENERATE PSEUDO CHANNELS

<u>Equation number</u>	<u>Parameter</u>	<u>Equation</u>
1.	Specific Volume	See enclosed Steam Table Algorithms
2.	Mass Flow Rate Steam	$MS = 1890 * CDS * F * DT^2 * FA * YA * SQRT(DI / VS)$ <p>CDS = Steam Orifice Discharge Coefficient</p> <p>VS = Specific Volume Steam</p> <p>P1 = Steam Orifice Input Pressure</p> <p>DI = Steam Orifice Pressure Drop</p> $YA = 0.684615 - 0.26923B^4 + DI / P1$ <p>B = DTS / DPS</p> <p>DTS = Throat Diameter Steam (Orifice)</p> <p>DPS = Pipe Internal Diameter, Steam</p> $FA = A0 + A1 * T1$ $F = 1 / SQRT(1 - B^4)$
3.	Mass Flow	$MW \text{ (or } MO) = 1890 * CD * DT^2 * F * FA * SQRT(D0 / VW)$

Rate Water

$D@ = D2$  for water

$D@ = D20$  for output

$CD = CDW$  for water - Orifice Discharge Coefficient

$CD = CDO$  for output

$FA = B0 + B1*T1$  for water

$FA = C0 + C1*T1$  for output

$DT = DTW$  for water Throat Diameter (Orifice)

$DT = DTO$  for output

$DP = DPW$  water internal Diameter

=  $DPO$  output internal Diameter

EQUATIONS USED TO GENERATE PSEUDO CHANNELS (Continued)

<u>Equation number</u>	<u>Parameter</u>	<u>Equation</u>
		$B = DT/DP$
		$F = 1/\text{SQRT}(1 - B^4)$
		$VW = VW$ specific volume water = $VO$ specific volume output
4.	MOM FLX	$\text{MOM FLX} = F1 + F2 + F3$
5.	VMS4	$VMS4 = VS4*MS^2$
6.	VMW4	$VMW4 = VW4*MW^2$
7.	RHOBAR	$\text{RHOBAR} = CS1*R1 + CS2*R2$  $CS1, CS2$ Flow Regime Constants.

<u>Equation number</u>	<u>Parameter</u>	<u>Equation</u>
8.	UBAR	$UBAR = Q1/A; A = \text{Area of Test Section} = \pi * D_{TEST}^2 / 4 * 144$
9.	M.D+T	$M.D+T = RHOBAR * Q1$
10.	M.D+DS	$M.D+DS = A * \text{SQRT}(RHOBAR * \text{MOM FLX}); A = \text{Area of T/S}$
11.	M.D+DD	$M.D+DD = A * \text{SQRT}(RHOBAR * F6)$
12.	M.T+DS	$M.T+DS = A * \text{MOM FLX} / UBAR$
13.	M.T+DD	$M.T+DD = A * F6 / UBAR$
14. a	RHOBAR	$RHOBAR = C11 * R4 + C12 * R5 + C13 * R6$ C11, C12, C13 Flow Regime Constants (two sets)
15.	UBAR	$UBAR = Q4/A; A = \text{Area of Test Section}$
16.	M.D+T	$M.D+T = RHOBAR * 4$
17.	M.D+DD	$M.D+DD = A * \text{SQRT}(RHOBAR * F5)$
18.	M.T+DD	$M.T+DD = A * F5 / UBAR$
19.	VMS	$VMS = VST / S * MS^2$
20.	VMW	$VMW = VWT / S * MW^2$

---

a. Equations 14 through 20 refer to the LOFT Test Program.

---

OUTPUT CONVERSION METHOD

<u>P-Channel</u>	<u>Parameter</u>	<u>To Convert from</u>	<u>to</u>	<u>Multiply By</u>
1.	Pressure	PSI	KP	6.894757
2.	Force	Lb <sub>m</sub> /ft-sec <sup>2</sup>	kg/m-sec <sup>2</sup>	1.488156
3.	Volume flow	ft <sup>3</sup> /s	m <sup>3</sup> /s	0.028316
4.	Temperature	F	C	5/9 (F-32)
5	Density	Lb <sub>m</sub> /ft <sup>3</sup>	kg/m <sup>3</sup>	16.01846
6.	Volts	volts	volts	1
<u>P CHANNEL</u>				
49-52	TSAT	F	C	5/9 (F-32)
53	VS	ft <sup>3</sup> /lb <sub>m</sub>	m <sup>3</sup> /kg	x/16.01846
54	HS	Btu/lb m	J/gm	2 326
55	VW	ft <sup>3</sup> /lb <sub>m</sub>	m <sup>3</sup> /kg	16.01846
56	HW	Btu/lb m	J/gm	2 326
57	VO	same as 53		
58	HO	same as 54		
59	MS	lb <sub>m</sub> /hr	kg/s	0.0001259979
60	MW	same as 59		
61	MO	same as 59		
62	VS4	same as 53		
63	HS4	same as 54		
64	MOM FLX	lb <sub>m</sub> /ft-sec <sup>2</sup>	kg/m-sec <sup>2</sup>	1.488156
65	VMS4	lb <sub>m</sub> ft <sup>3</sup> /hr <sup>2</sup>	m <sup>3</sup> kg/sec <sup>2</sup>	9.9107718E-1
0				
66	VMW4	same as 65		
67	RHOBAR	lb <sub>m</sub> /ft <sup>3</sup>	kg/m <sup>3</sup>	16.01846
68	UBAR	ft/s	m/s	0.3048

OUTPUT CONVERSION METHOD (Continued)

<u>P CHANNEL</u>	<u>Parameter</u>	<u>To Convert from</u>	<u>to</u>	<u>Multiply By</u>
69	M.D+T	lb <sub>m</sub> /s	kg/s	0.4535924
70	MD.+DS	same as 69		
71	M.D+DD	same as 69		
72	M.T+DS	same as 69		
73	M.T+DD	same as 69		
74 <sup>a</sup>	T10Sat	F	C	5/9 (F-32)
75	RHOBAR	same as 67		
76	UBAR	same as 68		
77	M.D+T	lb <sub>m</sub> /s	kg/s	0.4535924
78	M.D+DD	same as 77		
79	M.T+DD	same as 77		
80	VST/S	same as 53		
81	VWT/S	same as 54		
82	VMS	same as 65		
83	VMW	same as 66		

---

a. Channels 74 through 83 refer to LOFT Test Program

---

STEAM TABLE ALGORITHMS

Subroutine Prop (TW, PW, TS, PS VW, HW, VS, HS)

If (PS-PW) 2, 1, 2

1 X = ALOG (PW)

$$TW = 69.372 + 82.3946 * X - 28.72115 * X^{**2} + 10.81333 * X^{**3} - 2.130566 * X^{**4} + 0.252783 * X^{**5} - 0.0159195 * X^{**6} + 0.00042256 * X^{**7}$$

$$TS = TW$$

2 Y = TW/100.0

$$VW = 0.001 * (16.1844 - 0.717679 * Y + 0.99268 * Y^{**2} - 0.443779 * Y^{**3} + 0.122204 * Y^{**4} - 0.01712667 * Y^{**5} + 0.001000533 * Y^{**6})$$

$$HW = 32.4756 + 101.8866 * Y - 2.19336 * Y^{**2} + 0.972783 * Y^{**3} - 0.172796 * Y^{**4} + 0.016753 * Y^{**5}$$

$$P = PS/14.696$$

$$TAU = 1.0 / (TS - 32.0) * 5.0 / 9.0 + 273.16$$

$$ALPHA = 2641.62 * 10.0^{**} (80870.0 * TAU^{**2})$$

$$BETA = 2.3025809 * 80870.0 * TAU^{**2}$$

$$B\phi = 1.89 - TAU * ALPHA$$

$$GAMMA = ALPHA * (1.0 + 2.0 * BETA)$$

$$DELTA = 82.546 - 162460.0 * TAU$$

$$EPSIL = 0.21828 - 126970.0 * TAU^{**2}$$

$$RHO = 0.0003635 - 6.768E-8 * (1000.0 * TAU)^{**24}$$

$$A1UM1 = P^{**2} * ((B\phi * TAU)^{**2} * (4.0 * DELTA - 82.546) - 2.0 * DELTA * TAU^{**3} * B\phi * GAMMA) / 2.0$$

$$A2UM2 = (TAU * P)^{**4} * (B\phi^{**4} * (3.0 * EPSIL - 0.21828) / TAU - 2.0 * EPSIL * B\phi^{**3} * GAMMA) / 2.0$$

$$A3UM3 = (TAU * P)^{**13} * (B\phi^{**13} * (27.0 * RHO - 0.008724) / TAU - 13.0 * RHO * B\phi^{**12} * GAMMA) / 13.0$$

$$VS = 0.0160185 * (4.55504 / (TAU * P) + B\phi + B\phi^{**2} * TAU^{**2} * P * DELTA + B\phi^{**4} * (TAU * P)^{**3} * EPSIL - B\phi^{**13} * (TAU * P)^{**12} * RHO)$$

$$HS = 0.43 * (0.101325 * (P * (1.69 - 2.0 * TAU * ALPHA * (1.0 + BETA))) + A1UM1 + A2UM2 - A3UM3) + (1.472 / TAU + 0.00037783 / TAU^{**2} - 47.836 * ALOG (TAU) + 1803.7)$$

GDATA CALCULATIONS

<u>FUNCTION</u>	<u>EQUATION</u>	<u>UNITS</u>
1.	$P \text{ of } D = A + BX, X = \text{Input}$	Pressure psi
2.	$F = A + BX$	Lbm/ft-s <sup>2</sup>
3.	$Q = A + BX$	ft <sup>3</sup> /s
4.	$T = A + BX + CX^2 + DX^3$	°F
5.	$T5 = 50 + 5000/A - \text{SQRT}((50+5000/A)^2 - ((1000/(A*B))*(X/(C*D) - 1)))$	°F
6.	$R = A * \text{LN}(B/(X - C))$	Lb <sub>m</sub> /ft <sup>3</sup>
7.	$Z = X$	volts

<u>CHANNEL</u>	<u>FTN</u>	<u>STMT</u>	<u>NAME</u>	<u>EQ#</u>	<u>INPUT</u>
49	10		T1SAT Saturation Temperature T1	1	P1
50	10		T2SAT Saturation Temperature T2	1	P2
51	10		T3SAT Saturation Temperature T3	1	P3
52	10		T4SAT Saturation Temperature T4	1	P4
53	11		VS Specific Volume Steam	1	T1,P1
54	11		HS Enthalpy Steam	1	T2,P1
55	12		VW Specific Volume Water	1	T2
56	12		HW Enthalpy Steam	1	T2
57	12		V0 Specific Volume Output	1	T20
58	12		H0 Enthalpy Steam	1	T20
59	13		MS Mass Flow Rate Steam	2	D1,P1,T1,VS
60	14		MW Mass Flow Rate Water	2	D2,T2,VW
61	18		M0 Mass Flow Rate Output	2	D20,T20,VW

<u>CHANNEL</u>	<u>FTN</u>	<u>STMT</u>	<u>NAME</u>	<u>EQ#</u>	<u>INPUT</u>
62	15		VS4 Specific Volume T/S Steam	1	T4,P4
63	16		VW4 Specific Volume T/S Water	1	T4
64	17		MOMFLX Momentum Flux	3	F1,F2,F3
65	19		VMS4	4	VS4,MS
66	20		VMW4	5	VW4,MW
67	21		RHOBAR Density	6	R1,R2
68	22		UBAR Velocity	7	Q1
69	23		M.D+T Mass Flow Rate Densitometer + Turbine Meter	8	RHOBAR,Q1
70	24		M.D+DS Mass Flow Rate Densitometer + Drag Screen	9	RHOBAR,MOM FLX
71	25		M.D+DD Mass Flow Rate Densitometer + Drag Disk	10	RHOBAR,F6
72	26		M.T+DS Mass Flow Rate Turbine Meter + Drag Screen	11	UBAR,MOM FLX
73	27		M.T+DD Mass Flow Rate Drag Disk + Turbine Meter	12	F6,UBAR
74 <sup>a</sup>	10		T10SAT T10 Temperature Saturation	1	P7

<u>CHANNEL</u>	<u>FTN</u>	<u>STMT</u>	<u>NAME</u>	<u>EQ#</u>	<u>INPUT</u>
75	28		RHOBAR Density	13	P4,R5,R6
76	29		UBAR Velocity	14	Q4
77	30		M.D+DD Mass Flow Rate Densitometer + Turbine Meter	15	RHOBAR,Q1
78	31		M.D+DD Mass Flow Rate Densitometer + Drag Disk	16	RHOBAR,F5
79	32		M.T+DD Mass Flow Rate Turbine + Drag Disk	17	R5,UBAR
80	33		VST/S Specific Volume T/S Steam	1	T10,P7
81	34		VWT/S Specific Volume T/S Water	1	T10
82	35		VMS	18	VST/S,MS
83	36		VMW	19	VWT/S,MW

---

a. Equations 74 through 83 refer to the LOFT Program Test Channels.

APPENDIX C  
DATA VALIDATION ROUTINES

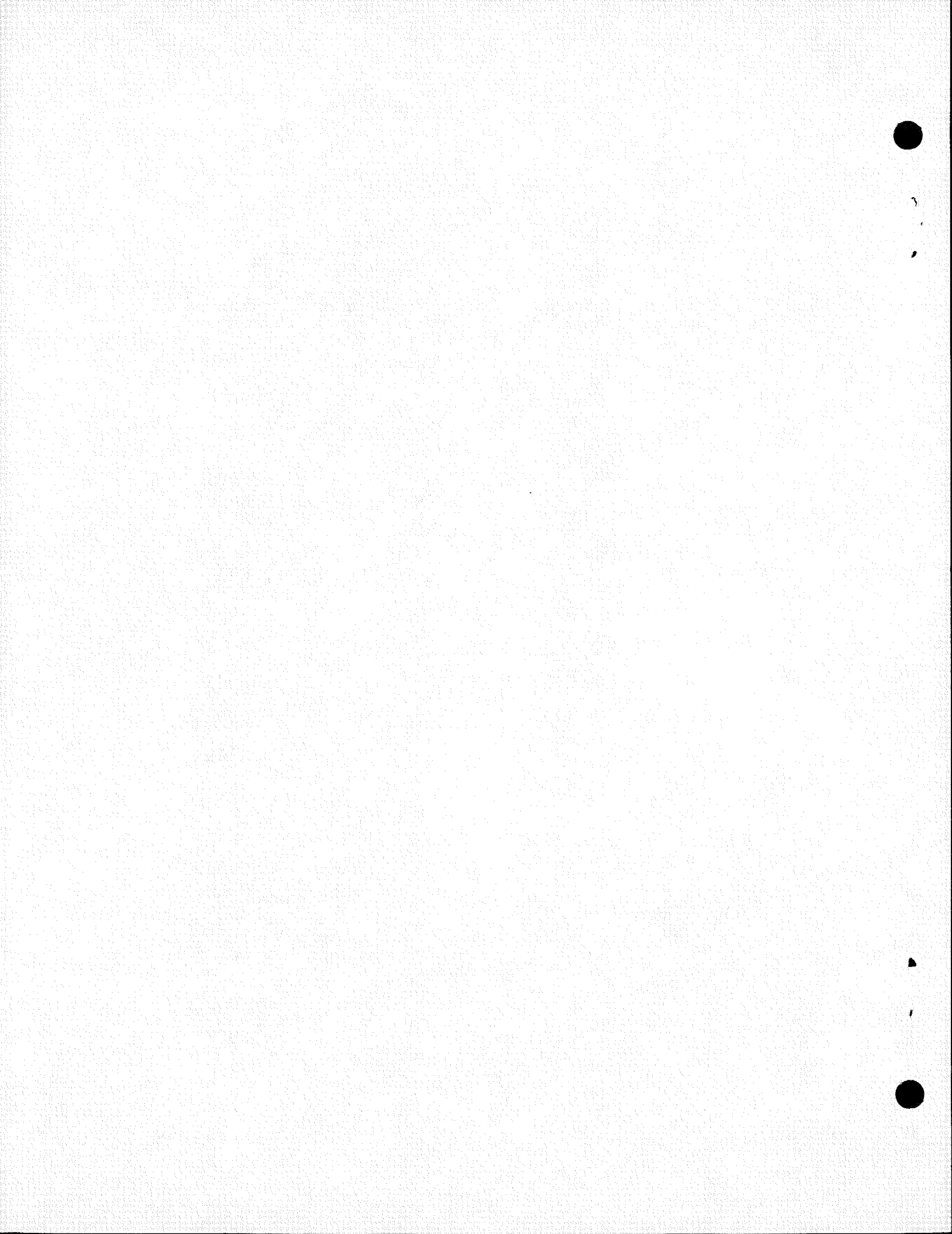

## APPENDIX C

### PDATA

Following are the calculations that PDATA performs:<sup>a</sup>

#### I. Mass Flow Rates:

1. If a mixing run is occurring, then the actual steam mass flow rate, MS, is subtracted from the specified mass flow rate steam (SMFRS) and printed out first;

$$\text{SMFRS-ACTUAL} = \underline{\hspace{2cm}}.$$

2. All run types perform the difference between specified mass flow rate water SMFRW and actual mass flow rate water MW,  $\text{SMFRW-ACTUAL} = \underline{\hspace{2cm}}.$

#### II. Pressure and Temperature Checks:

1. Difference between specified pressure 4 SP4 and actual P4 for all run types  $\text{SP4} - \text{PC} = \underline{\hspace{2cm}}.$
2. If the run type is Throttling, Cal Water, or Cal Steam then:
  - a. Difference between specified pressure 3 SP3 and actual P3;  $\text{SP3} - \text{P3} = \underline{\hspace{2cm}}.$
  - b. Difference between specified temperature 3 ST3 and actual;  $\text{T3 ST3} - \text{T3} = \underline{\hspace{2cm}}.$

#### III. Mass Balance Check:

1. If not a mixing run:  
 $\text{Mass Water} - \text{Mass out} = \underline{\hspace{2cm}} (\text{MASS IN} - \text{MASS OUT})$

---

a. Material in this appendix is abstracted from Reference 4.

PDATA (Continued)

2. If mixing run then:

$$\text{Mass Steam} + \text{Mass Water} - \text{Mass out} = \underline{\hspace{2cm}}.$$

IV. Energy Balance Checks:

1. If mixing run, then Energy In = Energy Steam + Energy Water.

2. If non-mixing run, then Energy In = Energy Water.

$$\text{Energy In} - \text{Energy Out} = \underline{\hspace{2cm}}.$$

## CDATA

The following calculations are made in CDATA.

### I. Saturation Checks:

1. For Semiscale, saturation temperatures for P1, P3, P4, and P5 are determined. Each saturation temperature is determined from steam table calculations using  $P_i$ .

Each saturation temperature is compared to actual temperature:  $T_{iSAT} - T_i = \underline{\hspace{2cm}}$ .

$T_1$  should always be greater than  $T_{1SAT}$ .

$T_2$  should always be lower than  $T_{2SAT}$ .

2. For LOFT saturation temperatures  $T_1$ ,  $T_2$ , and  $T_{10}$  are calculated.

### II. Pressure Checks:

This is done only for Semiscale. Essentially these checks should be close to zero as they are independent checks on the pressure gauges, both absolute and differential.

### III. Drag Body Constants:

These checks are made only during a water or steam calibration run. Each drag body constant is determined from the following equation:

$$K = A * 32.16 * F / (V_{T/S}^2 M^2)$$

A = Area of Test section

F = MOM FIX if Drag Screen is present

= F6 if drag disk of Semiscale is present

= F5 if drag disk of LOFT is present

$V_{T/S}$  = Specific volume at test section of LOFT or Semiscale

## CDATA (Continued)

- = VW specific volume water for Cal water
- = VS specific volume steam for Cal steam
- M = MS mass flow rate steam if Cal steam
- = MW mass flow rate water if Cal water

### IV. Mass Flow Rate Checks

Three independent mass flow rates are determined and compared to the sum of mass flow rates of water and steam (input quantities).

The three checks are:

1. Mass flow rate using densitometer plus drag disk (or screen) M.D+DD (M.D+DS).
2. Mass flow rate using turbine meter plus drag disk (or screen) M.T+DD (M.T+DS).
3. Mass flow rate using densitometer plus turbine meter M.D+T. See Appendix B for each calculation of these mass flow rates. In each case these mass flow rates are subtracted from the sum of the mass flow rate water and steam. This difference is printed.

### V. Turbine Checks

Each turbine meter is checked with the following calculation:

- M =  $Q \cdot 3600 / VT / S = \underline{\hspace{2cm}}$ .
- M1 = MW mass flow rate water; = MS mass flow rate steam.
- Q = flow rate,  $\text{ft}^3/\text{s}$
- = Q1 Semiscale
- = Q4 LOFT

C DATA (Continued)

VT/S = Specific volume water or steam at the test section.  
= Specific volume water if cal water.  
= Specific volume steam if cal steam.

VI. Densitometer Checks

The densitometers are checked by the following:

$$1/V - R = \underline{\hspace{2cm}}.$$

V = Specific volume at test section, water if Cal water, steam if Cal steam.

R = Densitometer reading.

For Semiscale, two values of R are used, R1 and R2; for LOFT, three R readings are used, R4, R5, R6.

VII. Differential Pressure Checks

Each differential pressure gauge is checked with the following:

$$D * 3.5708E6 * DTEST^4 / V_{T/S} M^2 = \underline{\hspace{2cm}}.$$

D = Differential Pressure Gauge, all values except D1, D2, and D20

DTEST = Diameter of test section

$V_{T/S}$  = Specific volume at test section; steam for Cal steam, water for Cal water.

M = Mass flow rate; MS for Cal steam, MW for Cal water.

The above equation should be constant.

## SDATA

The function of this subroutine is to print out the current values of P3, mass flow rate steam MS, and mass flow rate water MW. SDATA continues to print out these values until the switch register SW is changed (in any bit position). Upon changing SW, SDATA returns to the main program. At this point the operator can obtain more data, through calling GDATA, print out current values, of all channels, or call other subroutines.

SDATA changes the number of samples to 100 and the delay to zero. Upon returning to the main program, the number of samples and delay are restored to the original value as determined by the header HDR. When SDATA fetches data from GDATA, it obtains new values for all active channels, including P-channels.