

Received by OSTI

CONF 890855--2

MAR 31 1989

SAND--88-2237C

DE89 008713

**TESTING TO DETERMINE THE LEAKAGE BEHAVIOR OF INFLATABLE SEALS
SUBJECT TO SEVERE ACCIDENT LOADINGS**

M.B. Parks

Sandia National Laboratories, Division 6442, Albuquerque, N.Mex., USA

DISCLAIMER

This report was prepared as an account of work sponsored by an agency of the United States Government. Neither the United States Government nor any agency thereof, nor any of their employees, makes any warranty, express or implied, or assumes any legal liability or responsibility for the accuracy, completeness, or usefulness of any information, apparatus, product, or process disclosed, or represents that its use would not infringe privately owned rights. Reference herein to any specific commercial product, process, or service by trade name, trademark, manufacturer, or otherwise does not necessarily constitute or imply its endorsement, recommendation, or favoring by the United States Government or any agency thereof. The views and opinions of authors expressed herein do not necessarily state or reflect those of the United States Government or any agency thereof.

MASTER

DISTRIBUTION OF THIS DOCUMENT IS UNLIMITED

ps

DISCLAIMER

This report was prepared as an account of work sponsored by an agency of the United States Government. Neither the United States Government nor any agency thereof, nor any of their employees, makes any warranty, express or implied, or assumes any legal liability or responsibility for the accuracy, completeness, or usefulness of any information, apparatus, product, or process disclosed, or represents that its use would not infringe privately owned rights. Reference herein to any specific commercial product, process, or service by trade name, trademark, manufacturer, or otherwise does not necessarily constitute or imply its endorsement, recommendation, or favoring by the United States Government or any agency thereof. The views and opinions of authors expressed herein do not necessarily state or reflect those of the United States Government or any agency thereof.

DISCLAIMER

Portions of this document may be illegible in electronic image products. Images are produced from the best available original document.

1 INTRODUCTION

Under the sponsorship of the United States Nuclear Regulatory Commission, Sandia National Laboratories is currently developing test validated methods to predict the pressure capacity, at elevated temperatures, of light water reactor (LWR) nuclear containment vessels subject to loads well beyond their design basis - the so-called severe accident. Scale model tests of containments with the major penetrations represented have been carried to functional failure by internal pressurization. Also, combined pressure and elevated temperature tests of typical compression seals and gaskets, a full size personnel airlock, and of typical electrical penetration assemblies (EPAs), have been conducted in order to better understand the leakage behavior of containment penetrations (von Rieseemann, et al. 1988). Because inflatable seals are also a part of the pressure boundary of some containments, it is important to understand their leakage behavior as well. This paper discusses the results of tests that were performed to better define the leakage behavior of inflatable seals when subjected to loads well beyond their design basis.

2 BACKGROUND INFORMATION

Inflatable seals are used to prevent leakage around the perimeter of personnel and escape lock doors. They are fastened to the outer edge of the doors and, when pressurized with air, seal the gap between the door and the bulkhead. When deflated, there is a 3/8-inch gap between the sealing surface of the seals and the bulkhead. A typical application is shown in Figure 1. The pressure inside the seal is furnished by the instrument air supply system. After the door is closed and the seals are inflated, they are isolated from their pressure source by closed valves in the pressure lines. Thus, any increase in the seal temperature or in the external pressure applied to the seal will produce a corresponding change in the seal pressure.

These seals are either currently installed or planned for use in eleven commercial nuclear power plant containment structures in the United States. All of the installations are in either PWR or BWR Mark-III type containments. According to instructions from the supplier, the seal pressure must be at least 30 psi greater than the containment design pressure in order to ensure that leakage does not exceed design allowables. A survey of the plants that are currently using inflatable seals revealed that the normal operating seal pressure varied from plant to plant with a minimum seal pressure of 50 psig and a maximum of 110 psig. In all cases, the seal pressure is at least 30 psi greater than the containment design pressure.

0758

S

1

PARKS

During a review of the applications of inflatable seals, it was discovered that three different designs of inflatable seals are currently available for use in nuclear containments: an "old" design (Figure 2(a)), a "new" design (Figure 2(b)), and a modification of the old design. In some cases, the old design was found to have undesirably high amounts of leakage when compared to design allowable leak rates. In order to improve the leakage behavior, a 1/8-inch thick layer of EPDM E401 material was added to the sealing surface. The seals already fabricated using the old design were modified by vulcanizing a 1-1/2-inch wide by 1/8-inch thick layer of EPDM E401, 40 durometer material to the sealing surface. For the new design seals, the added E401 material is incorporated as an integral part of the seal as illustrated in Figure 2(b). This type of seal is currently supplied for use in nuclear containments. It should be noted that, other than the added E401 layer, the seals are constructed of EPDM E603, 60 durometer material with Kevlar reinforcement.

Only the old and new design seals were included in the test program. The old design seals were included because they are still in use in some containments. The modified old design seals were not tested since they were only supplied for a short period of time and because their leakage behavior should be at least as good as that of the old design seals.

3 DESCRIPTION OF TEST PROGRAM

The test program was designed to determine the leakage behavior of inflatable seals when subjected to external pressure conditions that are well beyond the seals design basis. External pressure was applied by placing the test fixture containing the inflatable seals inside a pressurized test chamber as shown in Figure 3. Figure 4 presents a schematic of the test setup. As depicted in Figure 4, the seal on the pressure input side of the fixture is denoted as the "inner" seal and the seal opposite the pressure input is the "outer" seal. (This notation corresponds to an actual airlock in which the innermost seal is exposed directly to the containment pressure). Pressure enters the fixture through circular openings on the inner side. Leakage past the inner seal may be measured through ports located between the seals; whereas, leakage past both seals may be measured through ports on the outer side of the test fixture.

As shown in Figure 3, the overall shape of the test fixture is that of a short length of cylinder with an outer diameter of approximately 36 inches and a length of approximately 13 inches. The plate to which the seals are attached is about 32 inches in diameter. Thus, the circumferential length of the tested seals is approximately 100 inches as compared to a total length of about 240 inches for a typical 6'-6" X 3'-6" personnel airlock door.

The primary objectives of the inflatable seals test program are listed below:

- 1) Determine required differential pressure, Δ , between the seal pressure and chamber pressure to prohibit a) any noticeable leakage; and b) significant leakage, approximately 10,000 std. ft³/day (scfd). (Leakage of 10,000 scfd corresponds to 1% volume/day of a 1*10⁶ ft³ containment volume at standard temperature and pressure.)
- 2) Compare the leakage behavior of the old and new seal designs.
- 3) Determine relationship between amount of leakage and Δ .
- 4) Determine effect of aging and seal temperature on Δ .

As outlined in Table 1, a total of four different series of inflatable seals tests have been performed. The first two tests were of the old seal design whereas the last two tests were of the new design. For each type of seal, an unaged (Test series 1 and 3) and an aged (Test series 2 and 4) pair of seals were tested. For each test series, the seals were tested first at room temperature and then at elevated temperatures at or above 300°F. The test temperatures are based on estimates of the airlock seal temperature which would

be caused by postulated BWR Mk-III or PWR severe accident conditions within the containment.

The aged inflatable seals were subjected first to radiation aging and later to thermal aging. The seals received a total gamma radiation dose of 200 Mrd which was applied at a rate of less than 1 Mrd/hr. Also, these seals were thermally aged for 1 week (168 hr) at 250°F. The aging process described above is intended to produce similar properties in the seal material as would be expected after being subjected to a loss of coolant accident at the end of a 10 year life.

4 TEST PROCEDURE AND RESULTS

Each series of tests for a given pair of inflatable seals began with room temperature tests. During the room temperature tests, leakage past both seals was limited to a maximum of 10,000 scfd so that minimal damage would occur and thus, the same pair of seals could later be tested for elevated temperature conditions.

4.1 Room Temperature Tests

Separate tests were performed at room temperature in which the initial seal pressure of the unaged seals (Test series 1 and 3) was varied from 50 to as much as 100 psig in increments of 10 psi. Table 2 lists the initial seal pressure levels that were included in each test series. (Note that because the seals were isolated from their pressure source by closed valves, the pressure within the seals increased from their initial level, as the external pressure in the test chamber increased.) Because the seals for test series 2 and 4 were aged, there was some concern that any testing at room temperature might damage the seals before the elevated temperature tests. In order to minimize any potential damage, only the 60 psig seal pressure level was tested at room temperature for test series 2 and 4.

To ensure that no damage occurred during any of the room temperature tests, the minimum seal pressure level was retested after completion of all other room temperature tests and the results compared to the first test at that pressure level. No significant change in leakage behavior was observed for test series 1, 2, and 4. However, for test series 3 the leakage behavior for the second 50 psig seal pressure test was much different from the first (see Table 2). Thus, a second "round" of room temperature tests were conducted for test series 3 in which the 50 through 80 psig seal pressure levels were repeated. No further change in leakage behavior was observed after the second round.

For each seal pressure level, the chamber pressure was increased from 0 psig until leakage past both seals reached approximately 10,000 scfd. The measured chamber pressure at which leakage of 10,000 scfd occurred for each seal pressure level is provided in Table 2. For test series 1, Figure 5 shows the recorded leakage past both seals as a function of chamber pressure for each seal pressure level. As expected, the chamber pressure required to produce leakage of 10,000 scfd increases as the initial seal pressure is increased. Also, note that, for each pressure level, leakage of 10,000 scfd did not occur until the chamber pressure exceeded the initial seal pressure.

4.2 Elevated Temperature Tests

Once the inflatable seals test fixture reached the desired temperature, the elevated temperature tests were conducted in basically the same manner as the room temperature tests. The main exception being that, because the elevated temperature tests were destructive in nature, only one seal pressure level could normally be tested for a given pair of seals. The test temperatures and

initial seal pressure level for each test series are summarized in Table 3. (Again, the pressure within the seals increased from their initial level, as the temperature and the external pressure within the test chamber increased.)

While still at room temperature, the seal pressure was set to the level shown in Table 3. A combination of internal heaters and a flow of heated, dry air or steam was used to heat the test chamber and inflatable seals test fixture to the desired test temperature. Once at the test temperature, the chamber temperature was maintained using heated, dry air. The chamber pressure was increased from 0 psig until leakage past both seals exceeded 30,000 scfd - the capacity of the flowmeters. For every test, leakage grew suddenly at failure from less than 5,000 scfd to greater than 30,000 scfd with no appreciable increase in chamber pressure (<2 psi). The internal seal pressure, at elevated temperature, was normally within 5 psig of the chamber pressure when failure occurred. The measured leakage past both seals at 300°F for test series 2, 3, and 4, is shown in Figure 6 as a function of chamber pressure.

By comparing Tables 2 and 3, it can be seen that, for a given initial seal pressure, a larger chamber pressure was usually necessary to cause significant leakage at elevated temperature than at room temperature. However, it should be noted that, at elevated temperature, significant leakage normally began as a result of a rupture in the seal tube; thus, it was impossible for the seals to reseal once the chamber pressure was reduced. Test series 3 was the only exception. For this test, the seals did not rupture during the 300°F test and thus, they were able to reseal upon reduction of chamber pressure. Because they were still intact, the chamber temperature was increased further to 350°F and another leakage test was performed. Although the seals also remained intact after this test, they ruptured, with virtually no chamber pressure applied, shortly after the temperature was increased to 400°F.

5 SUMMARY

The results of several tests to determine the leakage behavior of inflatable seals have been described. The test results indicate that, for temperatures of $\leq 300^\circ\text{F}$, significant leakage ($\geq 10,000$ scfd) should not occur if the chamber pressure is less than the initial seal pressure. As the initial seal pressure increases, the required difference between the chamber and initial seal pressure to cause significant leakage also increases. For example, for an initial seal pressure of 90 psig, the chamber pressure may be as much as 50% higher than the initial seal pressure before significant leakage occurs.

6 ACKNOWLEDGEMENT

This work was supported by the U. S. Nuclear Regulatory Commission and performed at Sandia National Laboratories, which is operated by the U. S. Department of Energy under contract number DE-AC04-76DP00789.

7 REFERENCE

von Rieseemann, W.A., et al. 1988. Sandia Programme Provides Insights Into Containment Integrity. Nuclear Engineering International. 40-42.

Table 1
Test Sequence

<u>Test Series No.</u>	<u>Seal Design</u>	<u>Seal Condition</u>	<u>Loading</u>
1	Old	Unaged	Air, Room Temp. & 400°F
2	Old	Aged	Air, Room Temp. & 300°F
3	New	Unaged	Air, Room Temp. & 300°F, 350°F
4	New	Aged	Air, Room Temp. & 300°F

Table 2
Summary of Room Temperature Tests
Test Series 1 Thru 4

<u>Initial Seal Pressure (psig)</u>	Chamber Pressure (psig) for Leakage Past Both Seals of 10,000 scfd				
	<u>Test Series 1</u>	<u>Test Series 2</u>	<u>Test Series 3</u>	<u>Test Series 3</u>	<u>Test Series 4</u>
			(Round 1)	(Round 2)	
50	51.1	----	93.0	58.2	-----
60	65.4	79.0	98.5	76.9	100.5
70	79.0	----	104.3	97.4	-----
80	94.7	----	125.1	129.1	-----
90	109.9	----	140.1	-----	-----
100	129.6	----	-----	-----	-----

Table 3
Summary of Elevated Temperature Tests
Test Series 1 Thru 4

<u>Seal Pressure at Room Temperature (psig)</u>	Chamber Pressure (psig) at Failure* of Seals				
	<u>Test Temperature (°F)</u>	<u>Test Series 1</u>	<u>Test Series 2</u>	<u>Test Series 3</u>	<u>Test Series 4</u>
50	400	132	---	---	---
90	300	---	180	180	138
90	350	---	---	145	---

*Failure is defined as leakage past both seals in excess of 30,000 scfd.

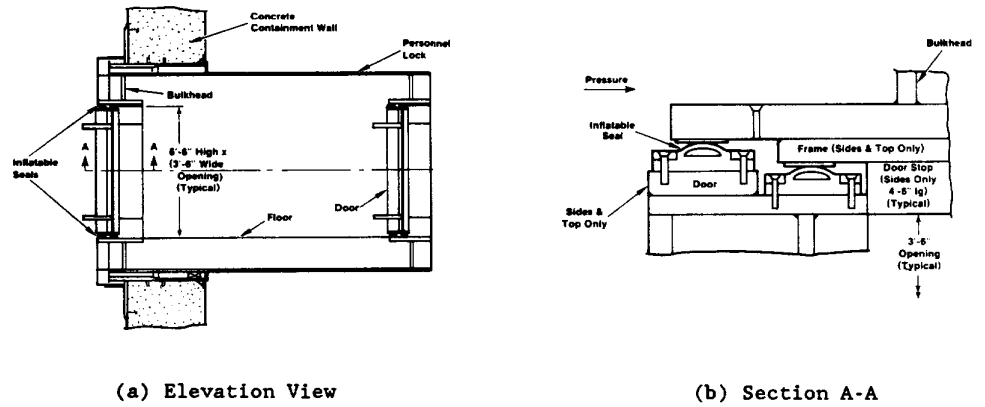
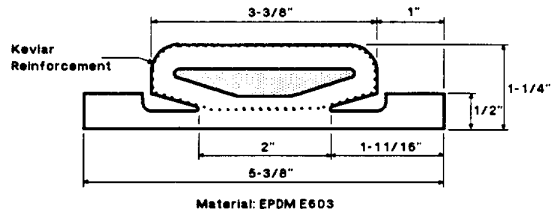
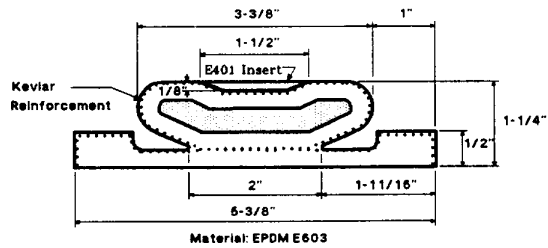

Figure 1. Typical Application of Inflatable Seals in a Personnel Lock Doors
(Note that seals are shown fully inflated.)



(a) "Old" Design



(b) "New" Design

Figure 2. Cross-Sectional Dimensions of Inflatable Seals Specimens

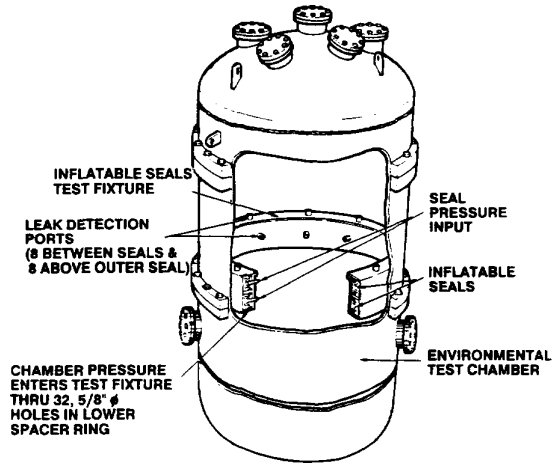

Figure 3. Inflatable Seals Test Fixture Inside Test Chamber

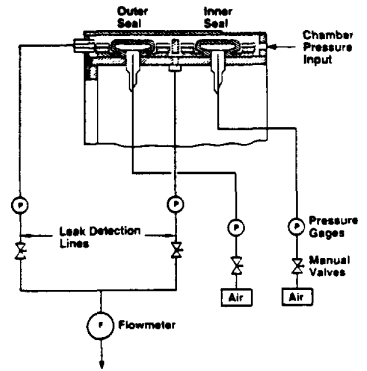

Figure 4. Schematic of Test Setup

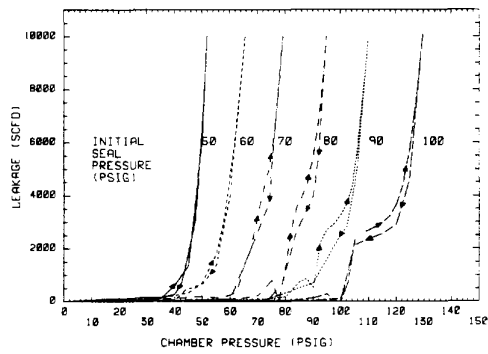

Figure 5. Comparison of Leakage for Various Seal Pressures - Test Series 1

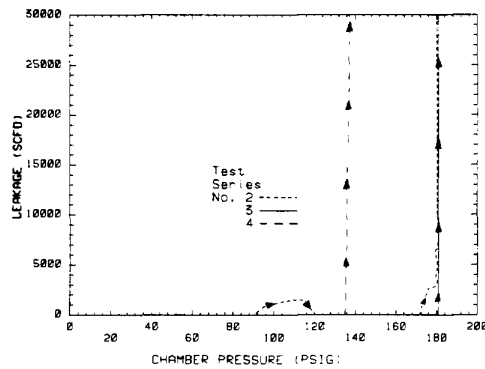

Figure 6. Comparison of Leakage at 300°F For Test Series 2, 3, and 4 (90 psig Initial Seal Pressure)