

3/1/83 JSD  
I-11621

UC-340

Dr. 1831-7  
LBL-16247



# Lawrence Berkeley Laboratory

UNIVERSITY OF CALIFORNIA

## Engineering & Technical Services Division

LBL--16247

DE84 001010

EVALUATION OF THE BEIJING INSTRUMENT FACTORY  
GDB-52LD PHOTOMULTIPLIER

E. Young and C.C. Lo

December 1982



MASTER

EVALUATION OF THE BEIJING INSTRUMENT FACTORY  
GDB-52LD PHOTOMULTIPLIER

Eric Young and C.C. Lo

Electronics Research and Development Group  
Department of Instrument Science and Engineering  
Lawrence Berkeley Laboratory  
University of California  
Berkeley, CA 94720

December 15, 1982

**DISCLAIMER**

This report was prepared as an account of work sponsored by an agency of the United States Government. Neither the United States Government nor any agency thereof, nor any of their employees, makes any warranty, express or implied, or assumes any legal liability or responsibility for the accuracy, completeness, or usefulness of any information, apparatus, product, or process disclosed, or represents that its use would not infringe privately owned rights. Reference herein to any specific commercial product, process, or service by trade name, trademark, manufacturer, or otherwise does not necessarily constitute or imply its endorsement, recommendation, or favoring by the United States Government or any agency thereof. The views and opinions of authors expressed herein do not necessarily state or reflect those of the United States Government or any agency thereof.

This work was performed as part of the program of the Electronics Research and Development Group of the Lawrence Berkeley Laboratory and was partially supported by the Director, Office of Energy Research, Office of High Energy Nuclear Physics, Division of High Energy Physics of the U. S. Department of Energy under Contract No. DE-AC03-76SF00098.

EVALUATION OF THE BEIJING INSTRUMENT FACTORY  
GDB-52LD PHOTOMULTIPLIER

Eric Young and C.C. Lo

Electronics Research and Development Group  
Department of Instrument Science and Engineering  
Lawrence Berkeley Laboratory  
University of California  
Berkeley, California 94720

Abstract

Characteristics have been measured for the GDB-52LD 2"-diameter photomultiplier. Some typical photomultiplier characteristics -- such as gain, dark current, anode output current, transit and rise times as a function of voltage between anode and cathode, and photoelectron pulse-height spectrum, the quantum-efficiency, and the single-electron transit time spread were measured. Descriptions of the measuring systems were also given.

Introduction

The GDB-52LD is a 5 cm diameter, flat face, ten stage, head on photomultiplier tube using a venetian blind type multiplier system. This tube has a bialkaline photocathode. The GDB-52LD photomultipliers are manufactured by the Beijing Comprehensive Instrument Factory.\* A photograph of the GDB-52LD photomultiplier is shown in Fig. 1.

\*Full address: China Nuclear Energy Industry Corporation  
(Beijing Comprehensive Instrument Factory)  
P.O. Box 2139,  
Beijing, China (P.R.C.)

### Gain and Dark-Current Measurements

The voltage divider, shown in Fig. 2, was used in measuring the gain and dark current. A block diagram of the system for the gain measurements is shown in Fig. 4. The light source was a 1B59 lamp driven by a 40-Hz square-wave generator. The dark current as a function of voltage between the cathode and anode was measured. The gain and dark-current characteristics of the multiplier as a function of the voltage applied between cathode and anode are shown in Fig. 5.

### Anode Output Pulse Current

The output pulse current performance depends on the voltage divider used and the applied voltage. The measurements of the output pulse current were made with the system shown as a block diagram in Fig. 6. The mercury light pulser, described in the LRL Counting Handbook CC8-30, was used as the light source. Using MELLES-GRIOT fused silica neutral density filters as light attenuators, the anode output pulse current as a function of light intensity was measured and plotted in Fig. 7. The intensity of the pulsed light source was kept constant during the measurement. The voltage divider shown in Fig. 3 was used for this measurement and all other measurements which follow.

### Electron Transit Time

The electron transit time was measured by means of the system shown in Fig. 8. The electrical signal from the mercury light source was used as the reference pulse. The transit time was measured from 50% of the leading-edge

amplitude of the reference pulse to 50% of the leading-edge amplitude of the photomultiplier output pulse. The results of the measurements are given in Fig. 9.

#### Anode-Pulse Rise Time

The measurement of the anode-pulse rise time was made by means of the system shown in Fig. 8. The output current pulse was chosen to be in the linear region of the anode's output current characteristics at the various voltage settings between the anode and cathode. The results of the measurement are shown in Fig. 10.

#### Single Electron Time Spread

A block diagram of the system used to measure single electron time spread is shown in Fig. 11. The measurement was made with the photocathode fully illuminated. The time distribution shown in Fig. 12 was found to be 18.5ns at FWHM.

#### Pulse-Height Resolution

The pulse-height resolution capabilities of the photomultiplier are significant for the detection and measurement of very low-light level scintillations in which only a few electrons are produced. High resolution permits the elimination of almost all single-electron dark pulses from the low-level scintillations.<sup>1,2</sup>

The pulse-height resolution of the GDB-52LD was measured by means of the system whose block diagram is shown in Fig. 13. A light-emitting diode driven by a pulse generator was used as the light-pulse generator. The pulse-height spectrum is shown in Fig. 14.

#### Quantum Efficiency

Quantum efficiency was measured by comparing the GDB-52LD with a calibrated RCA8850 PM Tube. QE was found to be 19.2% for one tube (SN10-3A) and 16.2% for the other tube (SN10-8A) at 410 nm.

#### Acknowledgment

This work was performed as part of the program of the Electronics Research and Development Group of the Lawrence Berkeley Laboratory and was partially supported by the Director, Office of Energy Research, Office of High Energy Nuclear Physics, Division of High Energy Physics of the U. S. Department of Energy under Contract No. DE-AC03-76SF00098.

The authors would like to express their appreciation to the China Nuclear Energy Industry Corporation (Beijing Comprehensive Instrument Factory) for the loan of the photomultipliers.

Reference to a company or product name does not imply approval or recommendation of the product by the University of California or the U. S. Department of Energy to the exclusion of others that may be suitable.

References

1. C. C. Lo and B. Leskovar, Evaluation of the 8850 Photomultiplier with a Cesium Gallium-Phosphide First Dynode, Lawrence Berkeley Laboratory, Engineering Note No. 1383, September 1971, University of California, Berkeley, California.
2. B. Leskovar and C. C. Lo, Performance Studies of Photomultipliers having Dynodes with GaP(Cs) Secondary Emitting Surface, IEEE Transaction Nucl. Sci., NS-19, No. 3, 60-72 (1972).
3. C. C. Lo and B. Leskovar, A Measuring System for Studying the Time Resolution Capabilities of Fast Photomultipliers, IEEE Transaction Nucl. Sci. NS-21 No. 1, 93-105 (1974).

Figure Captions

- Fig. 1. The GDB-52LD photomultiplier tube.
- Fig. 2. Schematic diagram of high gain divider.
- Fig. 3. Schematic diagram of high current divider.
- Fig. 4. Block diagram of the system for gain measurement.
- Fig. 5. Gain and dark current as a function of voltage between anode and cathode.
- Fig. 6. Block diagram of the system for anode output pulse current measurement.
- Fig. 7. Anode output pulse current as a function of light transmission of the optical attenuator.
- Fig. 8. Block diagram of the system for transit-time and rise-time measurement.
- Fig. 9. Transit time as a function of voltage between anode and cathode.
- Fig. 10. Anode pulse rise time as a function of voltage between anode and cathode.
- Fig. 11. Block diagram of the system for single electron time spread measurements.
- Fig. 12. Single electron time spread, full photocathode illuminated.
- Fig. 13. Block diagram of the system for pulse-height resolution measurements.
- Fig. 14. Pulse-height resolution response.

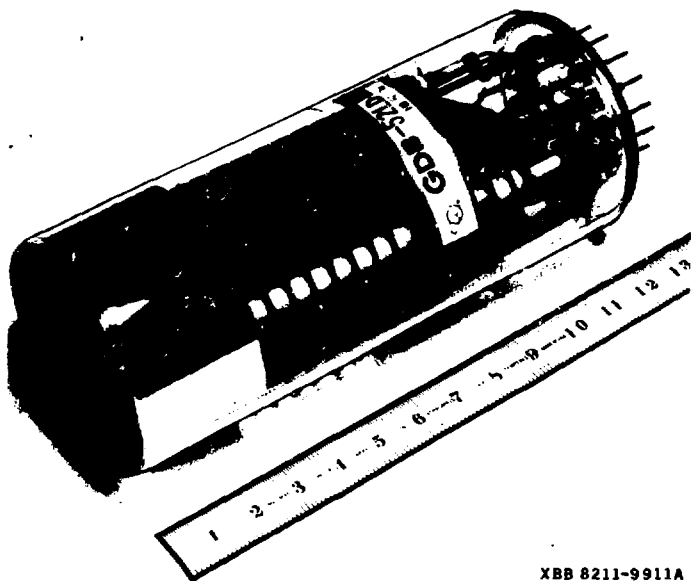

XBB 8211-9911A

Fig. 1. The GDB-52LD photomultiplier tube.



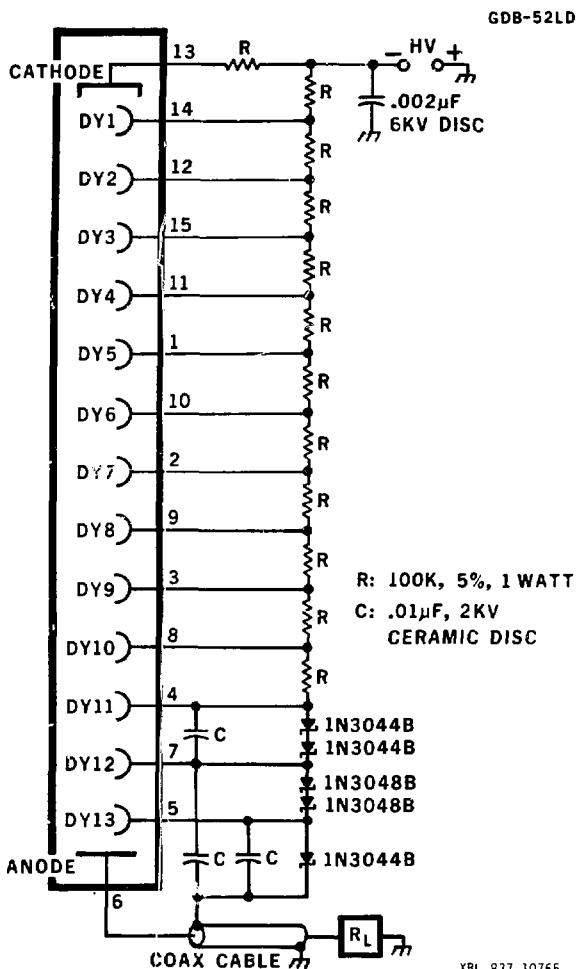
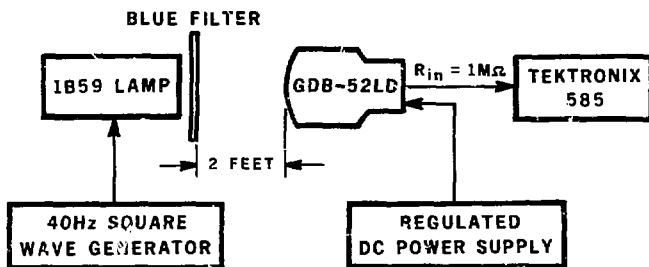
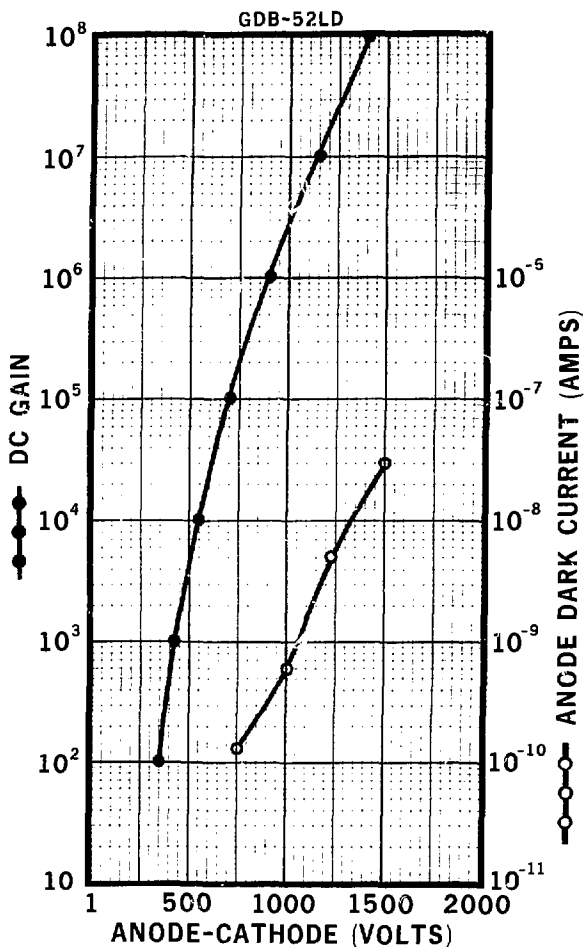

Fig. 3. Schematic diagram of high current divider.



XBL 837-10766

Fig. 4. Block diagram of the system for gain measurement.



XBL 837-10767

Fig. 5. Gain and dark current as a function of voltage between anode and cathode.

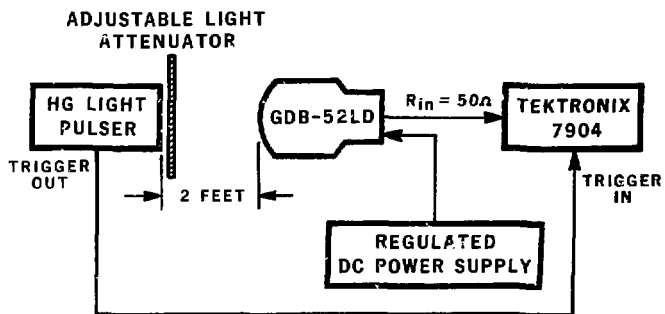

XBL 837-10768

Fig. 6. Block diagram of the system for anode output pulse current measurement.

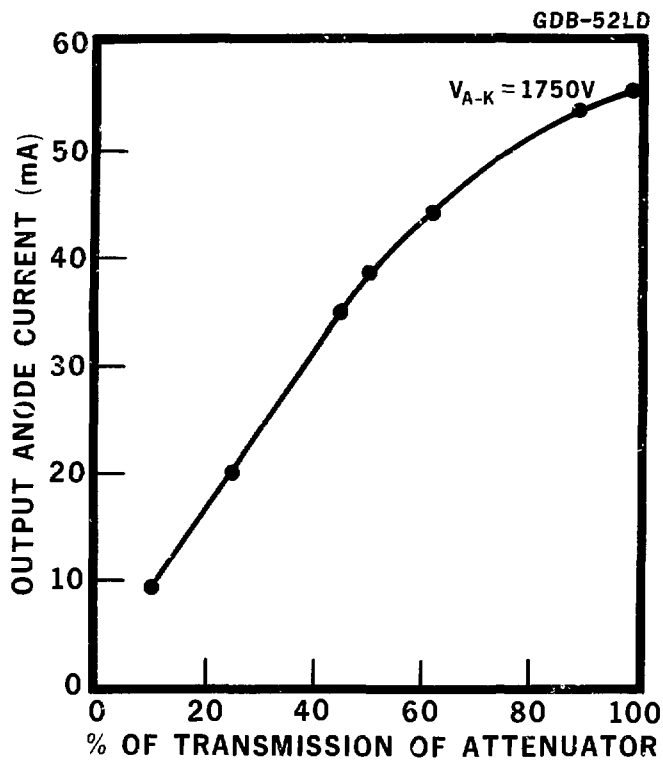

XBL 837-10769

Fig. 7. Anode output pulse current as a function of light transmission of the optical attenuator.

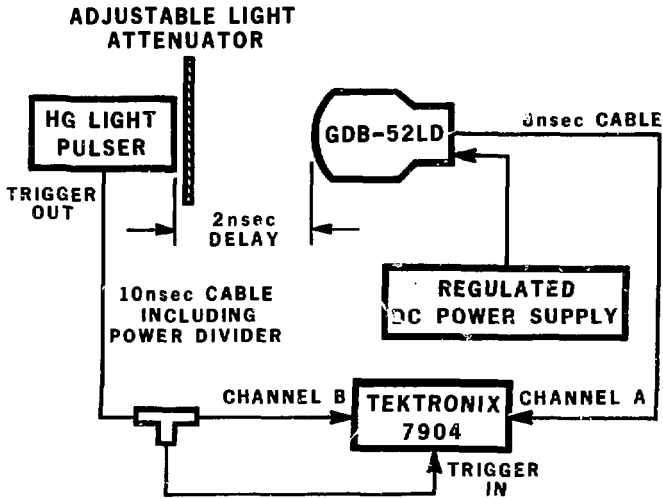

XBL 837-10770

Fig. 8. Block diagram of the system for transit-time and rise-time measurement.

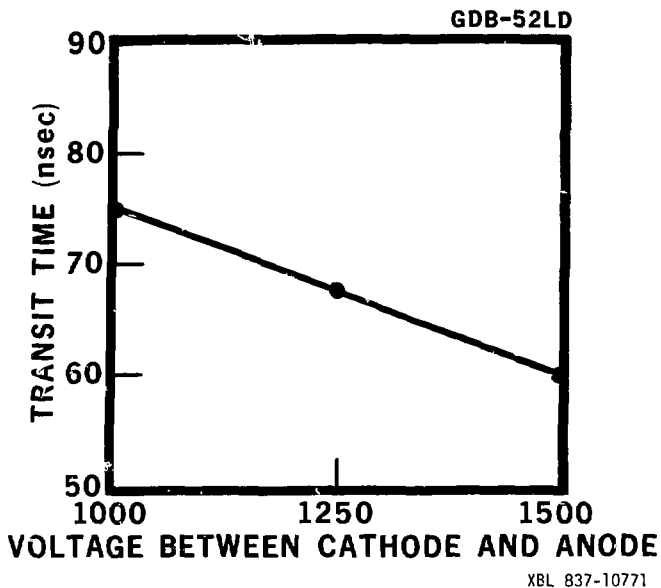
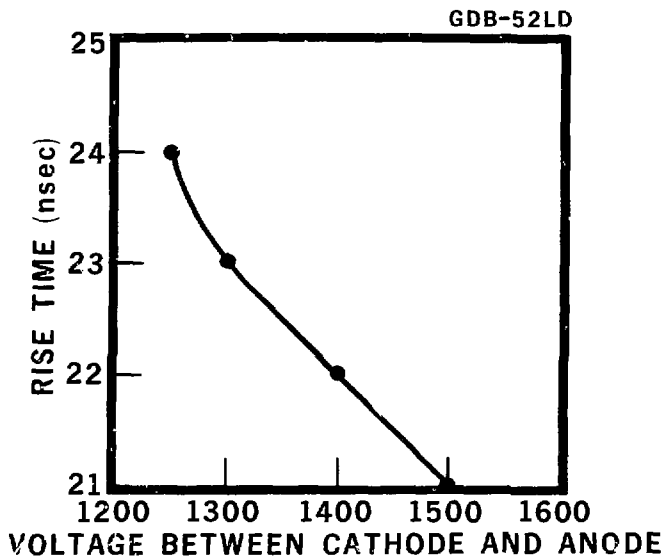
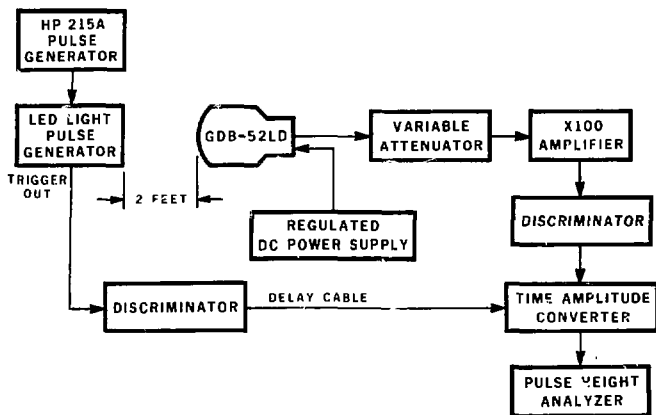

Fig. 9. Transit time as a function of voltage between anode and cathode.



XBL 837-10772

Fig. 10. Anode pulse rise time as a function of voltage between anode and cathode.



QBL 937-11273

Fig. 11. Block diagram of the system for single electron time spread measurements.

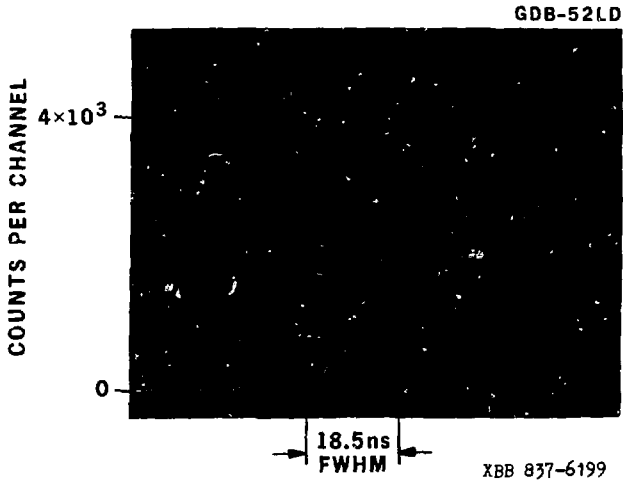
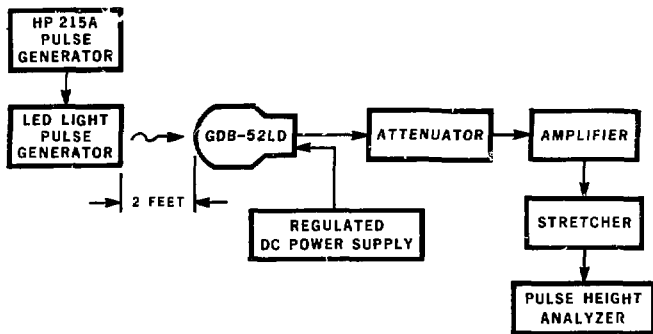

Fig. 12. Single electron time spread, full photocathode illuminated.



XBL 637-17774

Fig. 13. Block diagram of the system for pulse-height resolution measurements.

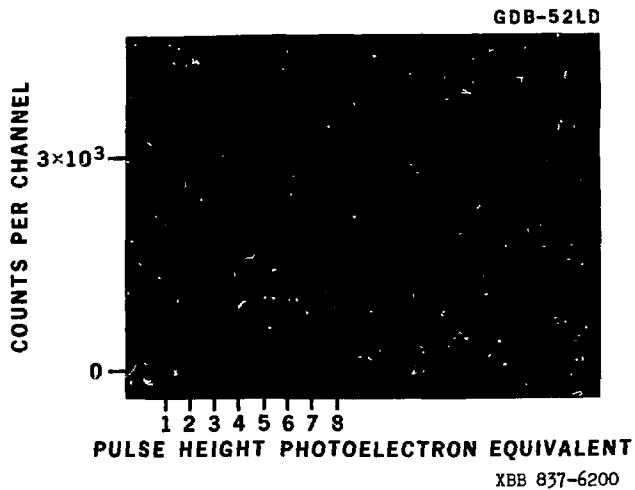

Fig. 14. Pulse-height resolution response.

This report was done with support from the Department of Energy. Any conclusions or opinions expressed in this report represent solely those of the author(s) and not necessarily those of The Regents of the University of California, the Lawrence Berkeley Laboratory or the Department of Energy.

Reference to a company or product name does not imply approval or recommendation of the product by the University of California or the U.S. Department of Energy to the exclusion of others that may be suitable.