

**EXPERIMENTAL PLAN FOR THE
FUEL-OIL STUDY**

Mark P. Ternes
William P. Levins
Marilyn A. Brown

January 1992

Prepared for the
Office of Technical and Financial Assistance
Weatherization Assistance Program Division
U. S. Department of Energy

Prepared by the
OAK RIDGE NATIONAL LABORATORY
OAK RIDGE, TENNESSEE 37831
Managed by
MARTIN MARIETTA ENERGY SYSTEMS, INC.
for the
U. S. DEPARTMENT OF ENERGY
under Contract DE-AC05-84OR21400

MASTER

TABLE OF CONTENTS

ACKNOWLEDGMENTS	v
ABSTRACT	vii
EXECUTIVE SUMMARY	ix
1. INTRODUCTION	1
2. EVALUATION GOALS	3
2.1 REGION-WIDE SPACE-HEATING FUEL-OIL SAVINGS	4
2.2 NON-ENERGY IMPACTS	4
2.2.1 Housing Affordability	4
2.2.2 Space-Heating System Safety and Efficiency	4
2.2.3 House Air Leakage	5
2.2.4 Indoor Temperature and Living Space	5
2.3 WEATHERIZATION COST EFFECTIVENESS	6
2.4 FACTORS INFLUENCING FUEL-OIL SAVINGS AND COST EFFECTIVENESS	6
2.5 MISCELLANEOUS	6
3. EVALUATION DESIGN	7
3.1 EXPERIMENTAL DESIGN	7
3.2 SAMPLING PROCEDURE	8
3.3 HOUSE ELIGIBILITY	10
3.4 SUPPLEMENTAL DESIGN	12
4. DATA PARAMETERS AND INSTRUMENTATION	13
4.1 TIME-SEQUENTIAL MEASUREMENTS	13
4.1.1 Space-Heating Fuel-Oil Consumption	14
4.1.2 Indoor Temperature Measurements	15
4.1.3 Outdoor Temperature Measurement	15
4.1.4 Billing and Delivery Data	15
4.2 SURVEY INFORMATION AND MEASUREMENTS	16
4.2.1 House Information	16
4.2.2 Occupant Questionnaire	17
4.2.3 Air-Leakage Measurement	17
4.2.4 Space- and Water-Heating System Measurements and Inspection	19
4.2.5 Subgrantee Information	19
4.2.6 Grantee Information	20

5. DATA ANALYSES	21
5.1 SPACE-HEATING FUEL-OIL SAVINGS	21
5.1.1 Submetered Data Analysis	21
5.1.2 Fuel-Oil Delivery Data	24
5.2 NON-ENERGY IMPACT ANALYSIS	24
5.3 COST-EFFECTIVENESS ANALYSIS	27
5.4 ANALYSIS OF FACTORS INFLUENCING SAVINGS AND COST EFFECTIVENESS	28
5.5 MISCELLANEOUS ANALYSES	29
6. PROJECT IMPLEMENTATION	31
6.1 PROJECT RESPONSIBILITIES	31
6.2 PROJECT TASKS AND SCHEDULE	32
7. KEY OUTCOMES	35
8. REFERENCES	37
APPENDIX A. SAMPLING ANALYSIS	39
APPENDIX B. HOUSE SCREENING CHECKLIST	61
APPENDIX C. INSTRUMENTATION LITERATURE	65
APPENDIX D. HOUSE CHARACTERISTICS SURVEY	77
APPENDIX E. PRE-WEATHERIZATION DATA COLLECTION FORM	89
APPENDIX F. OCCUPANT QUESTIONNAIRES	93
APPENDIX G. AIR-LEAKAGE MEASUREMENT TEST PROCEDURE	133
APPENDIX H. SPACE-HEATING SYSTEM STEADY-STATE EFFICIENCY MEASUREMENT PROCEDURE	141
APPENDIX I. OIL-FIRED SPACE- AND WATER-HEATING SYSTEM INSPECTION PROCEDURE	147
APPENDIX J. FUEL-OIL STUDY WEATHERIZATION INFORMATION SURVEYS ..	157

ACKNOWLEDGMENTS

Two working groups, a planning and implementation group and a methodology group, provided valuable input to the development of this experimental plan. The authors are grateful for the contributions of the individual members of these groups:

Jeff Ackermann
Colorado Department of Local
Affairs

Don Barnett
Missouri Department of Natural
Resources

Gary Bennethum
Office of Management and
Budget

Mary Ann Bernald
Edison Electric Institute

Jeff Brown
North Carolina Department of
Commerce
Energy Division

Dale Canning
Salt lake Community Action
Agency

Margaret Fels
Princeton University Center for
Energy and Environmental
Studies

Michael Foley
National Association of
Regulatory Utility Commissioners

Michael Ganley
National Rural Electric
Cooperative Association

Sharon Gill
Department of Energy
Chicago Support Office

Richard Gerardi
New York State Department of
State
Division of Economic Opportunity

Larry Goldberg
Sequoia Technical Services

Miriam Goldberg
Department of Energy
Energy Information
Administration

Judy Gregory
Center for Neighborhood
Development

Al Guyant
Public Services Commission of
Wisconsin

Ken Keating
Bonneville Power Administration

Martha Hewett
Center for Energy and the Urban
Environment

Larry Kinney
Synertech Systems Corporation

Lauri Krause
Office of Management and
Budget

Patrick Lana
Department of Energy
Kansas City Support Office

Judith Lankau
Orange and Rockland Utilities

Leon Litow
Department of Health and
Human Services

Ron Marabate
Michigan Department of Labor
Bureau of Community Services

Jane Marden
American Gas Association

John Mitchell
American Gas Association

Barry Moline
American Public Power
Association

John Nelson
Wisconsin Gas Company

Karl Pnazek
Community Action Program
Services

Meg Power
National Community Action
Foundation

Bill Prindle
Alliance to Save Energy

Ken Rauseo
The Commonwealth of
Massachusetts

Jeff Schlegel
Wisconsin Energy Conservation
Corporation

Theresa Speake
California Office of Economic
Opportunity

Ken Tohinaka
Champlain Valley Office of
Economic Opportunity,
Weatherization Program

Marjorie Witherspoon
National Association of State
Community Services Programs.

The authors would like to acknowledge the contributions of the following Oak Ridge National Laboratory staff working on the National Weatherization Assistance Program Evaluation to the development of this experimental plan: Tommy Wright, Linda Berry, Terry Sharp, and Jim Kolb. The authors would also like to thank Darrell Beschen (U.S. Department of Energy) for his insightful comments on the plan, as well as his support and guidance provided throughout its development. The input received from each of these individuals is greatly appreciated.

ABSTRACT

An up-to-date assessment of the Weatherization Assistance Program (WAP) is being performed by the U.S. Department of Energy WAP Division and the Oak Ridge National Laboratory. Five studies form the evaluation. Major goals of the Fuel-Oil Study are to estimate the fuel oil saved by the WAP in the Northeast during the 1990 and 1991 program years, identify and quantify non-energy impacts of the WAP, assess the cost effectiveness of the WAP within this submarket, and assess factors which may cause savings and cost effectiveness to vary.

The study will only analyze single-family houses in the nine states in the Northeast census region and will be carried out over two heating seasons (1990 and 1991 WAP program years). A split-winter, pre- and post-weatherization experimental design with a control group will be used. Houses will be monitored over one winter. Energy conservation measures will be installed in the weatherized houses in January of each winter by the local WAP subgrantee. One hundred twenty five weatherized houses and 75 control houses will be monitored over the 1990-1991 winter; a different set of 200 houses will be monitored over the 1991-1992 winter. The houses will be evenly distributed among 25 subgrantees.

Space-heating fuel-oil consumption, indoor temperature, and outdoor temperature data will be collected for all houses. Fuel-oil delivery data will be collected for each house monitored over the 1990-1991 winter for at least a year before weatherization. The delivery data will be analyzed to determine if the accuracy of the study can be improved by collecting fuel-oil delivery data on a larger sample of houses over the 1991-1992 winter.

Detailed survey information will be obtained on all the houses. This information includes descriptive details of the house and its mechanical systems, details on household size and other demographics, and occupant answers to questions regarding comfort, safety, and operation of their space-heating system and house. Information will be collected from the subgrantees on the measures installed in each weatherized house and their costs, the administration and program support costs for the subgrantee, and details on the overall program approach of the subgrantee. Information on state costs and program approaches will be collected from the grantees. In addition to this survey information, air leakage and space-heating system steady-state efficiency will be measured before and after weatherization in all houses. A safety inspection of the space- and water-heating systems will also be performed following weatherization in all houses.

Normalized annual space-heating fuel-oil consumptions needed to calculate savings will be estimated from the pre- and post-weatherization submetered data using a house energy consumption model. Program-induced improvements in the affordability of housing and space-heating, together with improvements in safety and comfort, will be assessed. The cost effectiveness of weatherization measures alone will be examined using appropriate economic indicators. Factors affecting fuel-oil savings and cost effectiveness will be assessed.

EXECUTIVE SUMMARY

Recognizing the need for an up-to-date assessment of the Weatherization Assistance Program (WAP), the U.S. Department of Energy (DOE) WAP Division requested Oak Ridge National Laboratory (ORNL) to help design and conduct a national WAP evaluation. Five separate studies are part of the overall evaluation. Major goals of the Fuel-Oil Study are to:

- provide a region-wide estimate of the fuel oil saved by the WAP in the Northeast during the 1990 and 1991 program years;
- identify and quantify (to the extent possible) non-energy impacts of the WAP such as housing and energy affordability, safety, and comfort;
- assess the cost effectiveness of the WAP within this submarket using a variety of economic indicators; and
- assess factors which may cause fuel-oil consumption, savings, and cost effectiveness to vary.

These major goals cover the most significant issues and also focus on producing useful and practical information for program planning, implementation, and management that can be obtained for reasonable costs. The Fuel-Oil Study, as well as the other studies, will provide essential inputs to the process of planning future roles for the WAP network in brokering, demonstrating, evaluating, and accelerating the market penetration of energy-efficient, cost-effective building technologies.

The Fuel-Oil Study is being carried out by ORNL at the request of the DOE WAP Division. The DOE WAP Division will monitor the study and provide needed management support. Two working groups organized by the DOE WAP Division (a methodology group and a planning and implementation group) will provide DOE input on technical issues, project focus, and application of results in support of the study. ORNL will manage the study by conducting or coordinating all study activities. ORNL will perform all data analyses and prepare a final report documenting the project and its results. The various State offices administering the WAP at the state level will enlist the cooperation of the subgrantees and provide program information. The subgrantees will weatherize the houses following their standard procedure. They will also assist in

house selection and instrumentation installation, provide information on the energy conservation measures (ECMs) installed and their cost, and provide information on their WAP approach and costs. Synertech Systems Corporation will assume the major role in implementing field related activities, in close cooperation with the above organizations. These activities will include instrumentation installation, maintenance, and removal, and data collection.

The Fuel-Oil Study will analyze single-family houses only and will cover the nine states in the Northeast census region (almost half of the single-family houses in the U.S. heated by fuel oil with occupants whose income is less than 125% of the poverty level are located in these nine states). The houses must meet six additional criteria to be eligible for the study. A split-winter, pre- and post-weatherization experimental design with a control group will be used. Submetered fuel-oil consumption will be monitored in all the study houses. Each house will be monitored over just one winter, with half the study houses being monitored over the 1990-1991 winter and the remaining half over the 1991-1992 winter. Weatherized houses will receive ECMs installed by the local WAP subgrantee. Inclusion of a control group allows estimation of energy consumption changes that would have occurred in the absence of the program.

In the split-winter design, houses are monitored over just one winter. ECMs will be installed in the weatherized houses during the middle of the winter (January). The split-winter design was chosen instead of a full winter of pre- and post-weatherization monitoring for the following reasons:

- houses serving as controls will be weatherized within a time frame agreeable to the states and subgrantees;
- the reduced number of houses to be monitored each winter per subgrantee makes it easier to identify the required number of houses for the study from current eligibility lists and reduces the time needed to install instrumentation;
- reuse of instrumentation over the 1991-1992 winter reduces instrumentation costs and allows indoor temperature to be monitored in all the houses;
- attrition will be reduced, which is particularly important because renters will be included in the sample; and

- the design can be easily modified for the 1991-1992 winter to accommodate a change in goals or to account for any unforeseen deficiencies which may arise during the 1990-1991 winter.

Disadvantages of the split-winter design include uncertainty associated with fuel-oil savings measured from shorter-term, split-winter testing and the need for subgrantees to weatherize all scheduled homes in a relatively short period in January. Previous studies performed with pre- and post-weatherization data collected over just half the winter have been successfully performed. Discussions with state WAP directors and subgrantee personnel have indicated that the subgrantees can weatherize houses in January sufficient for the study and that weatherization performed in the winter is quite similar to that performed during the summer.

A sample of 400 houses will be monitored over the two winters of the study. One hundred twenty five weatherized houses and 75 control houses will be monitored over the 1990-1991 winter; a different set of 200 houses will be monitored over the 1991-1992 winter. The houses will be evenly distributed among 25 subgrantees. The number of participating subgrantees in the nine states is as follows: Maine (2), New Hampshire (2), Vermont (2), Massachusetts (4), Rhode Island (2), Connecticut (2), New York (5), Pennsylvania (4), and New Jersey (2). Based upon 1990-1991 winter results, a decision will be made between monitoring periods to use the same subgrantees or a different set of subgrantees over the 1991-1992 winter to improve the accuracy of the study. Based on this sample size, the identified distribution, and use of the same 25 subgrantees both winters, the estimated savings should be within about 30% of the actual savings, at a 90% confidence level.

The following data will be monitored continuously (one-hour averages) in all the houses using a data logger: space-heating fuel-oil consumption, indoor temperature, and outdoor temperature. These data will be retrieved over telephone lines. Fuel-oil delivery data will also be collected for each house monitored over the 1990-1991 winter for at least a year before weatherization.

Detailed survey information will be obtained on all the houses. This information includes descriptive details of the house and its mechanical systems; details on household size and other demographics; and occupant answers to questions regarding comfort, safety, and operation of their

space-heating system and house. Information will be collected from the subgrantees on the measures installed in each weatherized house and their costs, the administration and program support costs for the subgrantee, and details on the overall program approach of the subgrantee. Information on state costs and program approaches will be collected from the grantees. In addition to this survey information, several measurements will be made on the houses. Air leakage and space-heating system steady-state efficiency will be measured before and after weatherization. A safety inspection of the space- and water-heating systems will also be performed following weatherization.

Normalized annual space-heating fuel-oil consumptions used to calculate savings will be estimated from the pre- and post-weatherization submetered data using a house energy consumption model. The model assumes that space-heating fuel-oil consumption is linearly related to the temperature difference between the inside and outside of the house. Linear regression techniques will be used to estimate model parameters for the pre- and post-weatherization periods for each house. Pre- and post-weatherization normalized annual space-heating fuel-oil consumptions will be calculated using the estimated model parameters found for each house, average outdoor temperatures from National Climatic Data Center Typical Meteorological Year weather tapes for each house location, and either the average pre- and post-weatherization indoor temperatures or a 68°F indoor temperature (savings based on a constant 68°F indoor temperature will be used in assessing factors that effect savings to eliminate this known source of variation). The normalized annual fuel-oil savings of each weatherized house will be adjusted using the average normalized annual savings of the control houses to account for non-program induced factors affecting space-heating fuel-oil consumption. Average regional fuel-oil savings from the WAP applied to houses heated by fuel oil will be determined using the normalized only (gross) and adjusted (net) fuel-oil savings estimated for each house (based on actual pre- and post-weatherization indoor temperatures).

The fuel-oil delivery data will be analyzed before the 1991-1992 winter to determine if the accuracy of the study can be improved by collecting fuel-oil delivery data on a larger sample of houses over the 1991-1992 winter. The analysis to be performed on the fuel-oil delivery data includes verifying their accuracy and reliability, that their correlation to weather data is acceptable, and that their estimate of pre-weatherization consumption compares favorably to

estimates made using submetered data. Pre-weatherization space-heating fuel-oil consumption for houses with sufficient and reliable delivery data will be determined using a degree-day approach such as the Princeton Scorekeeping Method (PRISM) and compared with the consumptions estimated from submetered data to determine the degree of agreement.

An assessment of program-induced improvements in the affordability of housing and space-heating will be conducted by combining fuel expenditure data with information on household income and rent or mortgage payments. Improvements in safety will be evaluated by determining the incidence of unsafe conditions with the space- and water-heating systems and remedial actions taken, or recommended, during weatherization. Program impacts on comfort will be assessed using monitored indoor temperatures, information on the number of rooms heated, and measured airtightness of the houses.

The cost effectiveness of the weatherization measures alone will be examined using indicators such as simple payback period, benefit-to-cost ratio, net present value, and cost of conserved energy. The identified indicators will be calculated using standard formulas, measured fuel-oil savings, known fuel prices, and the direct labor and material costs of the ECMs. Key assumptions made in the formulas include the expected lifetimes of the house and ECMs, a discount rate that reflects the time value of money, and estimated fuel-price escalation rates. Because of the uncertainty in these key assumptions, sensitivity analyses will be used to estimate a range of cost effectiveness under varying conditions. The cost effectiveness of the WAP will be determined by expanding the previous analysis to include other program benefits and costs. A societal perspective, which estimates societal benefits achieved per public dollar spent, will be emphasized. Non-energy impacts that can be estimated in monetary terms will be incorporated into this latter cost-effectiveness analysis.

Individual factors that may explain variations in fuel-oil savings and cost effectiveness will be examined by comparing group averages using appropriate statistical methods. Factors that will be examined include pre-weatherization fuel-oil consumption, climate, house characteristics, household demographics, packages of ECMs installed, service delivery procedures, and methods of client selection. These factors will also be used with multivariate statistical models to estimate the independent influence of single variables, controlling for the influence of other factors.

EXPERIMENTAL PLAN FOR THE FUEL-OIL STUDY

1. INTRODUCTION

Recognizing the need for an up-to-date assessment of the Weatherization Assistance Program (WAP), the U.S. Department of Energy (DOE) WAP Division requested Oak Ridge National Laboratory (ORNL) to help design and conduct a national WAP evaluation. Five separate studies are part of the overall evaluation (Beschen and Brown 1991). Three of these will address principal submarkets:

- single-family study (which also addresses small multifamily buildings),
- high-density multifamily study, and
- fuel-oil study.

The major goals of the Fuel-Oil Study are to:

- estimate fuel-oil savings due to the program in single-family houses heated by fuel oil (which is not part of the primary data analyses in the single-family study),
- assess non-energy impacts (e.g., energy affordability, safety, and comfort),
- assess program cost effectiveness, and
- analyze factors which may cause savings and cost effectiveness to vary.

These major goals cover the most significant issues and also focus on producing useful and practical information for program planning, implementation, and management that can be obtained for reasonable costs. For example, information from the evaluation will be useful for identifying how to best allocate WAP resources, the market segments (such as high energy users) that future program efforts should target under specific circumstances, the service delivery procedures that are most effective for particular building types, the packages of measures that are shown to provide the most benefit, and the level of energy savings that can be expected per public dollar spent.

The Fuel-Oil Study, as well as the other studies, will provide essential inputs to the process of planning future roles for the WAP network in brokering, demonstrating, evaluating, and accelerating the market penetration of energy-efficient, cost-effective building technologies.

The Fuel-Oil Study will analyze single-family houses only and will cover the nine states in the Northeast census region. This study will be carried out over two heating seasons (1990 and 1991 WAP program years) and will involve submetered field measurements of space-heating fuel-oil consumption in approximately 400 houses. The cooperation of the various state offices in charge of administering the WAP is essential to the execution and success of this project, as is the cooperation of the randomly selected subgrantees.

Two working groups were organized by DOE to review the evaluation and provide recommendations for improvement. Comments received from these groups were considered together with other project constraints in the development of this plan.

2. EVALUATION GOALS

There are four main goals of the Fuel-Oil Study. The primary goal is to provide a region-wide estimate of the fuel oil saved by the WAP in the Northeast during the 1990 and 1991 program years (a program year runs from April to March). This estimate will focus on fuel oil used for space heating. Space cooling is not prominent in this region and will not be addressed.

The second goal is to identify and quantify (to the extent possible) non-energy impacts of the WAP. This analysis will focus on program-induced improvements in the affordability of housing due to reduced household energy costs; reductions in the number of unsafe space- and water-heating systems due to remedial actions taken or recommended during weatherization; and improvements in the comfort of houses due to reduced draftiness, increased indoor temperature, and increased amount of heated living space. The occupants' perception of comfort improvements will also be studied.

The third goal is to assess the cost effectiveness of the WAP within this submarket using indicators such as simple payback period, benefit-to-cost ratio, cost of conserved energy, and net present value. A range of inputs to the analysis about future fuel prices, lifetimes of energy conservation measures (ECMs), and discount rates will be used to develop results encompassing the perspectives of most use and interest.

The final goal is to assess factors which may cause fuel-oil consumption, savings, and cost effectiveness to vary. This assessment will provide insights about groups of measures that are effective in reducing fuel-oil consumption, service delivery procedures that lead to enhanced cost effectiveness, and market segments that future program efforts should consider targeting. Factors of interest include climate, dwelling unit characteristics prior to weatherization, packages of ECMs, audit procedures, and other service delivery differences.

Some of the major evaluation questions to be addressed by the study to meet the above goals follow. This list is meant to be illustrative and not exhaustive.

2.1 REGION-WIDE SPACE-HEATING FUEL-OIL SAVINGS

1. What is the pre-weatherization space-heating fuel-oil consumption of the control and weatherized homes normalized to typical weather conditions and actual indoor temperatures? Normalized to a typical (68°F) indoor temperature?
2. What is the change in space-heating fuel-oil consumption of the control houses normalized to typical weather conditions and actual indoor temperatures, and expressed as energy savings per year and as a percentage of pre-weatherization consumption? Normalized to a typical (68°F) indoor temperature? Averaged across the region?
3. What is the change in space-heating fuel-oil consumption of the weatherized houses normalized to typical weather conditions and actual indoor temperatures, unadjusted and adjusted by the control house savings, expressed as energy savings per year and as a percentage of pre-weatherization consumption? Normalized to a typical (68°F) indoor temperature? Averaged across the region?

2.2 NON-ENERGY IMPACTS

2.2.1 Housing Affordability

1. What percent of household income is spent for energy consumption? How does this value change following weatherization?
2. What percent of household income is spent for housing (rent or mortgage payment plus energy utilities)? How does this value change following weatherization?
3. Do occupants perceive an improvement in the affordability of housing due to receiving assistance from the WAP?

2.2.2 Space-Heating System Safety and Efficiency

1. Following weatherization, how many of the space-heating systems are identified as having the following safety problems: cracked heat-exchanger, excessive carbon monoxide (CO) in the flue gases (incomplete combustion), smoke in the flue gases (incomplete combustion), CO in the air surrounding the system, CO in the distribution air (forced-air system), insufficient draft, damaged flue/chimney, improperly installed flue/chimney, oil leak, improperly set safety switches, improperly set pressure switches (boiler systems), and missing or dirty filters?

2. How many space-heating systems having the types of safety problems identified above prior to weatherization were corrected during weatherization or as the result of a recommendation at the time of weatherization?
3. How many of the control houses have these safety problems?
4. Is there a significant difference in the level of incidence of these problems between the weatherized and control houses?
5. What is the pre-weatherization steady-state efficiency of the space-heating systems? What is the change in steady-state efficiency of the space-heating systems following weatherization? Does space-heating system work affect changes in steady-state efficiency?
6. What is the average steady-state efficiency of the space-heating systems in the control houses? How does that compare to the weatherized houses?

2.2.3 House Air Leakage

1. What is the pre-weatherization air leakage of the control and treatment group homes? How do they compare?
2. What is the change in air leakage of the weatherized and control houses following weatherization? How do the changes compare?
3. Do occupants perceive a reduction in the draftiness of their house following weatherization?
4. What is the average expenditure for airtightening (air-leakage reduction) work?
5. Assuming that all air-leakage reduction is due to airtightening work (reductions achieved indirectly from other measures are credited to the airtightening work), what is the estimated cost effectiveness of this work?
5. Does the use of a blower door for training, locating leakage sites, determining when to stop airtightening work, and/or for inspection affect the achieved reductions, expenditures, and estimated cost effectiveness?

2.2.4 Indoor Temperature and Living Space

1. What is the pre-weatherization house indoor temperature? What is the time-of-day indoor temperature profile before weatherization?
2. What is the change in house indoor temperature and profile following weatherization?

3. Do occupants perceive an improvement in comfort following weatherization?
4. What change in the number of rooms heated occurs following weatherization?

2.3 WEATHERIZATION COST EFFECTIVENESS

1. What is the average expenditure for space-heating system ECMs installed under the WAP and other programs?
2. What is the average cost effectiveness of the installed ECMs, expressed as a simple payback period, benefit-to-cost ratio, net present value, and cost of conserved energy?
3. What is the program support and administration cost of conducting the WAP?
4. In monetary terms, what benefits other than fuel-oil savings result from the WAP?
5. What is the average cost effectiveness of the WAP, including all costs and benefits?

2.4 FACTORS INFLUENCING FUEL-OIL SAVINGS AND COST EFFECTIVENESS

1. What service delivery features, house characteristics, occupant characteristics, and packages of ECMs create differences in group savings or correlate with fuel-oil savings and cost effectiveness?

2.5 MISCELLANEOUS

1. What are the general characteristics of the houses studied (geographic areas, construction types, wall and floor areas, insulation levels, space-heating system characteristics, glass area, house age, etc.)?
2. What are the general characteristics of the occupants (number, age, income levels, ownership status, etc.)?
3. Were the weatherized and control groups equivalent relative to dwelling unit and occupant characteristics? If they have different characteristics, how does this affect the estimates of fuel-oil savings and cost effectiveness?

3. EVALUATION DESIGN

3.1 EXPERIMENTAL DESIGN

A split-winter, pre- and post-weatherization experimental design with a control group will be used (see Fig. 3.1). Submetered fuel-oil consumption will be monitored in all the study houses. Each house will be monitored over just one winter, with half the study houses being monitored over the 1990-1991 winter and the remaining half over the 1991-1992 winter.

Group 1	1990-1991 Winter	
Weatherized group (125 houses)	pre	W post
Control group (75 houses)	pre	post W
Group 2		1991-1992 Winter
Weatherized group (125 houses)		pre W post
Control group (75 houses)		pre post W

Note: **W** = Weatherization

Fig. 3.1. Split-winter experimental design.

Weatherized houses will receive ECMs installed by the local WAP subgrantee. Pre- and post-weatherization testing allows individual house space-heating fuel-oil savings to be determined because the houses serve as their own reference. Individual house savings are then averaged to determine group savings. Inclusion of a control group allows estimation of energy consumption changes that would have occurred in the absence of the program. For instance, it controls for factors such as differing ground temperatures between the pre and post periods and trends in the price of fuel oil. Savings for weatherized houses can be adjusted by the savings for the control group to account for these factors.

In the split-winter design, houses are monitored over just one winter. ECMs will be installed in the weatherized houses during the middle of the winter (January). The split-winter design was chosen instead of a full winter of pre- and post-weatherization monitoring for the following reasons:

- Houses serving as controls will be weatherized within a time frame agreeable to the states and subgrantees.
- Instead of monitoring all study houses over two winters as needed under a full winter of pre- and post-weatherization monitoring, the split-winter design allows half the houses to be monitored one winter and the remaining half the second winter. The reduced number of houses to be monitored each winter makes it easier to identify the required number of houses for the study from current eligibility lists and reduces the time needed to install instrumentation. Additionally, reuse of instrumentation for the 1991-1992 winter reduces instrumentation costs and allows indoor temperature to be monitored in all the houses.
- Attrition will be reduced, which is particularly important because renters will be included in the sample.
- The design can be easily modified for the 1991-1992 winter to accommodate a change in goals or to account for any unforeseen deficiencies which may arise during the 1990-1991 winter.

Disadvantages of the split-winter design include uncertainty associated with fuel-oil savings measured from shorter-term, split-winter testing and the need to weatherize all scheduled homes in a relatively short period in January. Previous studies performed with pre- and post-weatherization data collected over just half the winter (McCold et al. 1988, Ternes et al. 1991) have been successfully performed. Discussions with state WAP directors and subgrantee personnel have indicated that subgrantees can weatherize houses in January sufficient for the study and that weatherization performed in the winter is quite similar to that performed during the summer.

3.2 SAMPLING PROCEDURE

A sample of 400 houses will be monitored over the two winters of the study and will be drawn from the population of houses meeting the eligibility requirements listed in Sect. 3.3.

Available resources limited the total number of houses to 400. The houses will be divided into 250 weatherized houses and 150 control houses. Over the 1990-1991 winter, 125 weatherized houses and 75 control houses will be monitored and distributed evenly among 25 subgrantees. Over the 1991-1992 winter, the remaining 125 weatherized houses and 75 control will be monitored and again evenly distributed among 25 subgrantees.

Three sampling options exist. Under the first option, houses will be drawn from the same 25 subgrantees for both the 1990-1991 and 1991-1992 winters. The second option will use a different set of 25 subgrantees over the 1991-1992 winter. In the third option, houses will be sampled from half the original 25 subgrantees and for 10-15 new subgrantees. At a 90% confidence level and assuming a 20% attrition rate, the estimated savings of the installed ECMs should be within 32% of the actual savings if the first option is chosen, within 26% if the second option is chosen, and between 26% and 32% if the third option is chosen (see Appendix A). A specific option has not been selected at this time because of uncertainty in the error estimates and uncertainty regarding costs associated with acquainting additional subgrantees with the study, providing training to them about the instrumentation, and acquiring subgrantee related information. A final decision will be made before the 1991-1992 winter based upon an analysis of the 1990-1991 winter's data.

For the 1990-1991 winter, a clustered sampling procedure will be used: 25 subgrantees will first be selected using the states as a stratification variable; eight individual houses per subgrantee will then be selected. The selection of houses will proceed in two steps:

1. A total of 25 subgrantees will be selected from the nine northeast states and distributed as follows: Maine (2), New Hampshire (2), Vermont (2), Massachusetts (4), Rhode Island (2), Connecticut (2), New York (5), Pennsylvania (4), and New Jersey (2). At least two subgrantees will be chosen from each state to ensure a representative sample. Subgrantees from each state that weatherize a significant number of single-family houses heated by fuel oil (typically greater than 15 such houses per year) will be identified. Sampling is limited to these subgrantees to ensure that eight houses eligible for the study can be identified from the subgrantee if selected. The sample of subgrantees for each state will be drawn randomly with probabilities proportional to the number of single-family houses heated by fuel oil and weatherized by the subgrantee.
2. For each subgrantee selected, houses currently on the waiting list and/or selected for weatherization that meet the eligibility requirements listed in Sect. 3.3 will be identified.

A random sample of eight of these houses will then be chosen. Their eligibility for the study will be verified through a house visit and using the form provided in Appendix B. The household's consent (and building owner's if the household is a renter) will also be obtained. If these requirements cannot be met, a replacement house will be selected. If eight eligible houses are not currently available, then additional outreach will have to be performed to obtain the necessary number of houses.

The eight houses selected from each subgrantee will be randomly divided into a weatherization and control group during the pre-weatherization period. These assignments will be made as late as possible to minimize the effect of attrition on creating unequal groups.

To thank those households participating in the study for any inconveniences they may endure and for services to be provided during the study, the following monetary payments will be made to the occupants the winter their house is monitored: a \$75 service payment to each participating household in January, and an additional \$75 payment to each control house in May. If necessary, these payments can be used as an incentive to obtain the participation of the households.

3.3 HOUSE ELIGIBILITY

Houses included in the study will be limited to those with the following characteristics:

1. Occupants must be eligible for the WAP administered in their State for the 1990 or 1991 program years.
2. Houses must be single-family buildings but not mobile homes, mobile homes with room additions, or other similar housing assembled on-site from factory built modules. A single-family building is defined in the Residential Energy Consumption Survey (RECS) (Energy Information Administration 1989):

"[A] single-family housing unit [is] a structure that provides living space for one household or family. The structure may be detached, attached on one side (semidetached), or attached on two sides. Attached houses are considered single-family houses as long as the house itself is not divided into more than one housing unit and has an independent outside entrance. A single-family house is contained within walls that go from the basement (or the ground floor, if there is no basement) to the roof. (A mobile home with one or more rooms added is classified as a single-family home.)"

Although a mobile home with one or more rooms added is classified as a single-family house in RECS, such a house will not be considered for this study. Energy savings and weatherization techniques for mobile homes are being examined by other DOE sponsored studies and, thus, are not included in this study. In interpreting the RECS definition, row houses and side-by-side duplexes (twins) are single-family houses, whereas over-and-under duplexes are small multifamily buildings (see definition below).

Small multifamily buildings are also defined by RECS:

"[A] house or building with two to four housing units [is] a structure that is divided into living quarters for two, three, or four families or households. This category also includes houses originally intended for occupancy by one family (or for some other use) that have since been converted to separate dwellings for two to four families. Typical arrangements in these types of living quarters are separate apartments downstairs and upstairs, or one apartment on each of three or four floors."

Energy savings of single-family and small multifamily buildings heated by fuel oil will not be assessed using primary data in the Single-Family Study (Berry et al. 1991). Small multifamily buildings are not currently included in the Fuel-Oil Study to simplify the design and its implementation, a simplification especially needed to allow monitoring to start during the 1990-1991 winter. The 1987 RECS data (Energy Information Administration 1989) indicate that there are almost three times as many single-family households heated by oil with occupants whose income level is less than 125% of the poverty level as small multifamily households.

High-density multifamily buildings (five or more units per building) heated by fuel oil will be assessed under the High-Density Multifamily Study (Beschen and Brown, 1991).

3. Primary space-heating systems must use fuel oil. Single-family houses primarily heated by other common fuels such as gas and electricity will be assessed in the Single-Family Study (Berry et al. 1991).
4. Houses must be located in the nine states in the northeast census region (Maine, New Hampshire, Vermont, Massachusetts, Rhode Island, Connecticut, New York, Pennsylvania, and New Jersey). The 1987 RECS data (Energy Information Administration 1989) indicated that almost half of the single-family houses heated by fuel oil with occupants whose income is less than 125% of the poverty level are located in these nine states. About 70% of all households that use fuel oil as their main heating fuel are located in these states; about 40% of the households in these states heat with fuel oil (households in these statistics include all income levels and building types).
5. Secondary space-heating systems (such as wood stoves, fireplaces, or portable space heaters) must not be used to substantially heat a house (use of supplemental space-heating systems one day per week or in the bathroom is acceptable). Energy consumption of secondary space-heating systems cannot easily be monitored.

6. Occupants must intend to remain at home for the entire winter monitoring period (no lengthy vacations away from home). Houses whose occupants move during the study will likely be dropped from the analysis.
7. Occupants must have a working telephone line in the house. Data collected by the data logger installed in each house will be collected over the telephone.

3.4 SUPPLEMENTAL DESIGN

Fuel-oil delivery data will be collected from dealers serving the houses monitored over the 1990-1991 winter. These data will be analyzed to verify their accuracy and reliability, that their correlation to weather data is acceptable, and that their estimate of pre-weatherization consumption compares favorably to estimates made using the submetered data. Depending on available funding and the results of this supplemental analysis performed using the fuel-oil delivery data collected over the 1990-1991 winter, fuel-oil delivery data will be collected on a larger sample of houses over the 1991-1992 winter to improve the overall study accuracy.

4. DATA PARAMETERS AND INSTRUMENTATION

The data to be collected for this study can be divided into two types: time-sequential data and survey data. The time-sequential data are recorded on an hourly basis: space-heating system fuel-oil consumption, indoor temperature, and outdoor temperature. The survey data are essentially point-in-time measurements and will include descriptive information and evaluations of the building shell and mechanical systems of the house, information on occupant characteristics and their responses to weatherization, cost information, and other information characterizing the states and subgrantees.

4.1 TIME-SEQUENTIAL MEASUREMENTS

A model R-2400 data logger made by Telog Instruments, Inc. (Appendix C) will be used to measure and record the time-sequential data at each house. Units used for this study will have four channels (two temperature, one pulse/event, and one analog voltage) and no display. The unit measures 8-in x 10-in x 5-in and is programmable. Internal batteries, capable of powering the unit for about 3 months, will be used as a back-up power supply to externally-provided power. Communications with the unit will be established using an internal modem. Data will be retrieved over telephone lines using the internal modem and software developed by Telog Instruments, Inc. The unit measures temperature and analog voltage (which will monitor space-heating system run-time) once a second. For a user-programmed interval, the unit stores an average result over the interval in solid state memory. The unit also records the time (day, hour, minute, and second) that an event (contact closure and/or open) occurs by continuously monitoring the event channel. The event channel will not be used in this study.

This data logger was selected after researching many options, testing three promising units, and consulting with other monitoring experts regarding available options. Previous experience with a single-channel recorder made by Telog Instruments, Inc. has shown this type of unit to be reliable and sufficiently accurate. Other large users of this equipment have indicated to us that the equipment works well.

4.1.1 Space-Heating Fuel-Oil Consumption

The energy delivered to the oil-fired space-heating system will be calculated from a measurement of the run-time of the oil burner. The hourly run-time will be multiplied by the rated flow of the nozzle on the burner and by the higher heating value of fuel oil (approximately 140,000 Btu/gal) to arrive at the Btu input into the burner each hour. This is not the energy delivered into the house, but that delivered to the burner. The heating value of the fuel oil will also be assumed to remain constant unless detailed data as to its actual value are available. An on-site calibration of the oil burner flow rate will not be performed unless it is deemed that this will significantly increase overall experimental accuracy. The rated flow rate of the nozzle will be documented at the time instrumentation is installed and removed.

The run-time of the oil burner will be measured using the Telog R-2400 data logger's analog voltage channel and a low-voltage (contact closure) relay placed across the pump motor of the oil burner. The relay will close when power is supplied to the pump (delivering oil to the burner) and will open when power to the pump is interrupted. The data logger will supply the relay with a voltage source of approximately 8 volts which will be read as 5.12 volts by the data channel (its maximum or "pegged" range) when the system is on, and 0.00 volts when off. By recording the average voltage over a set time period, the run-time of the oil burner will be calculated by dividing the average voltage by 5.12 volts (i.e. 5.12 volts = 100% on time, 3.1 volts = 60.54% on time, etc.). Because the data logger will be programmed to record an average hourly voltage, approximately two months of voltage data can be retained in the unit.

This approach measures burner run-time rather than the time the thermostat is calling for heat. Thus, it is applicable to most fuel-oil space-heating systems likely to be encountered in this study, especially hydronic systems, in which the thermostat controls a pump circulating heated water through the house rather than delivery of fuel to the burner. The actual amount of fuel delivered to the oil burner is accurately estimated so long as the oil pump maintains a delivery pressure to the nozzle which maintains a steady flow equal to the rated nozzle flow. The low voltage relay is attractive for safety and liability reasons.

4.1.2 Indoor Temperature Measurements

The indoor temperature of each house will be monitored at the thermostat using an integrated-circuit temperature sensor and the Telog R-2400 data logger. In houses where the thermostat location is "unusual" and non-representative of the interior temperature, a more appropriate location will be identified. The temperature at the thermostat was chosen because the thermostat operates the space-heating system in response to this temperature and because this temperature is often representative of the house temperature. The sensor will be installed to minimize its exposure to radiant energy from the sun, exterior walls and windows, lamps, and other significant radiators. The sensor will also not be exposed to heat or cold sources such as vents or appliances in the surrounding area. The data logger will be programmed to record an average hourly temperature. Under this configuration, approximately two months of temperature data can be retained in the unit.

4.1.3 Outdoor Temperature Measurements

The outdoor temperature at each house will be monitored using an integrated-circuit temperature sensor and the Telog R-2400 data logger. The temperature sensor will be located where it is unaffected by heat sources or sinks in the surrounding area and where the ambient air is well mixed with the surrounding air. A sensor location on the north side of the house and below roof level will be preferred. The data logger will be programmed to record an average hourly temperature. Under this configuration, approximately two months of temperature data can be retained in the unit.

For use in analysis with the fuel-oil delivery data, average daily outdoor temperature data compiled by the National Climatic Data Center (NCDC) will be collected for the same time periods covered by the delivery data.

4.1.4 Billing and Delivery Data

Electric billing and fuel-oil delivery data will be collected for each house for at least a year before and a year after weatherization. Using the fuel-release form on file for each client with

the subgrantee, these data will be collected directly from the electric utilities and fuel distributors. Fuel-oil prices will also be collected from the contacted fuel distributors.

4.2 SURVEY INFORMATION AND MEASUREMENTS

Detailed survey information will be obtained on all the houses participating in the study. This survey information includes descriptive details of the house and its mechanical systems; details on household size and composition; and occupant answers to questions regarding comfort and safety, their operation of the space-heating system, and their house. This information will be primarily collected after weatherization, although some information will be collected during the pre-weatherization period.

In addition to this detailed survey information, several other measurements will be made on the houses. Air leakage will be measured using a blower door both before and after weatherization. The steady-state efficiency and smoke reading of the space-heating system will be measured before and after weatherization. A safety inspection of the space- and water-heating systems will also be performed following weatherization.

Information will be collected from the subgrantees on the measures installed in each weatherized house and their costs, administration and program support costs for the subgrantee, and details on the overall program approach of the subgrantee. Information on state costs and program approaches will be collected from the grantees.

4.2.1 House Information

Information summarizing the physical characteristics of the house and its space-heating, space-cooling, and water-heating systems will be collected in all houses at the end of the post-weatherization period using the survey provided in Appendix D. Information on the floor area, volume, number of rooms, and number of heated rooms will also be collected at the beginning of the pre-weatherization period in all houses using the form provided in Appendix E.

4.2.2 Occupant Questionnaire

A comprehensive occupant questionnaire will be conducted at the end of the post-weatherization period. Subjects to be included are ownership status (renter or owner), length of residence, house age, heating fuels, demographics, the amount of conditioned space, thermostat management, fuel assistance, and occupant perceptions of impacts on health, safety, comfort, and affordability. A majority of the questions in the questionnaire (Appendix F) have been reprinted verbatim from the 1990 RECS. This will make it possible to compare results from this study with data collected from the nationwide RECS. A similar questionnaire will be used in the Single-Family Study to facilitate comparisons and generalizations across studies. All questions that are not drawn from RECS will be pretested. Approval from the Office of Management and Budget will be obtained for the questionnaire.

4.2.3 Air-Leakage Measurement

Air-leakage tests will be performed in all the houses using calibrated Infiltec blower doors (Appendix C). Each weatherized house will be tested before and after weatherization in order that the total air-leakage change caused by the combined weatherization measures can be determined. Control houses will also be tested during the pre- and post-weatherization periods. Data to be collected include blower-door air flow rates at different pressure differences between the inside and outside of the house, indoor and outdoor temperature during the test, and local shielding class.

The air-leakage tests will be performed following the procedure provided in Appendix G. The procedure minimizes errors from procedural differences between technicians. It also minimizes gauge-induced errors due to calibration and hysteresis. The procedure is sufficiently rigorous to ensure comparability of individual house measurements made under this study and the Single-Family Study even after considering that

- tests will be performed by different personnel in the Fuel-Oil Study,
- tests will be performed by different organizations with, perhaps, different brands of blower doors between the Fuel-Oil and Single-Family Studies, and

- houses will be located in a wide variety of locations, elevations, and terrains, and will likely have air leakages that vary greatly.

This procedure was adapted from a procedure developed for the Bonneville Power Administration to evaluate air-leakage characteristics of over 500 Northwest houses (Ecotope 1989). Bonneville's procedure has been extensively field tested and proven capable of producing high quality results - i.e., collecting data with minimal random errors that can be extrapolated to the required conditions for standard analysis with the Lawrence Berkeley Laboratory (LBL) Infiltration Model (Sherman and Modera 1984).

To further minimize errors, the same blower door will be used to make the pre- and post-weatherization measurements in each house.

Only tests in which the house volume is depressurized will be performed. Both depressurized and pressurized tests (averaged to obtain a composite result) are specified in ASTM Standard E779-87 for measuring air leakage (ASTM 1987) to reduce the effect of random errors in individual data sets and thereby increase the accuracy of estimating the air leakage. This approach was selected based on a study performed by LBL (Sherman et al. 1984). LBL determined that systematic errors between pressurized and depressurized tests did not occur, but significant random errors in individual tests could be compensated for by combining the results from both tests. Results from the Bonneville project (upon which the test procedure in Appendix G is based) indicated that the pressurization test did not improve the accuracy of the air-leakage measurement or reduce its standard error. Based on these latter results and because of the increased cost to perform a pressurized test (especially to seal all vent areas), pressurized tests will not be performed.

For this test, the house will be measured in its normal leakage condition. Under this condition, only those openings in the envelope that can naturally be sealed (such as windows, external doors, fireplace dampers) are closed for the test rather than sealing all possible openings in the envelope (such as vents, animal gates, and window air conditioners). Reasons for this choice are:

- to represent the "as found" condition of the house desired for the evaluation,
- to test the house in the condition requiring the least modification by testing personnel to limit the time required for setup of the house, and
- to reduce the number of special leakage areas sealed for the pre-weatherization test that must be replicated for the post-weatherization test to ensure comparable results.

4.2.4 Space- and Water-Heating System Measurements and Inspection

The steady-state efficiency of the space-heating system will be measured in all houses during the pre- and post-weatherization periods. These measurements will be made with a Lynn model 6500B analyzer (Appendix C) following the procedure in Appendix H. In addition, a smoke test will be conducted when the efficiency is measured.

A safety inspection of the space- and water-heating systems will be performed at the end of the post-weatherization period in all houses. The inspection will include examination for cracked heat-exchanger, excessive carbon monoxide (CO) in the flue gases (incomplete combustion), CO in the air surrounding the system, CO in the distribution air (forced-air system), insufficient draft, damaged or improperly installed flue/chimney, oil leak, improperly set safety switches, improperly set pressure switches (boiler systems), and missing or dirty filters. If an unsafe condition is found, it will be brought to the attention of the subgrantee and grantee and resolved either through the WAP or this study. The inspection will be performed using a Lynn Products Model 7400 Carbon Monoxide Analyzer and 460 Draft Gauge, and following the procedure in Appendix I.

4.2.5 Subgrantee Information

Information on service delivery procedures (audit type, use of contractor or in-house crews, use of blower doors, inspection procedures, etc.), the dates the houses were weatherized, measures installed and their costs, the average administration and program support (non-labor and non-material) costs per housing unit for the subgrantee, and household income will be collected from the weatherized houses using the survey presented in Appendix J. Household income will

also be collected from the control houses (survey provided in Appendix J). The number of single-family houses heated by fuel oil and weatherized in each program year will be obtained. The number that received work improving the safety of the space- or water-heating systems will also be obtained.

4.2.6 Grantee Information

Information on program costs for the grantees will be collected from DOE so that the cost of State-level activities such as administration, training, technical assistance, and education can be incorporated into the cost-effectiveness analysis. Grantees will provide estimates of the number of single-family houses heated by fuel oil that were weatherized in each of the study program years.

5. DATA ANALYSES

5.1 SPACE-HEATING FUEL-OIL SAVINGS

5.1.1 Submetered Data Analysis

Space-heating fuel-oil savings will be defined in two ways:

1. the annual savings normalized to an average weather year for the house location, and
2. the annual savings normalized to an average weather year for the house location and a constant 68°F indoor temperature.

The former definition of the savings will be used in reporting the savings achieved by the WAP and determining cost effectiveness. This savings is based on the actual average pre- and post-weatherization indoor temperatures maintained in each house. The latter definition of the savings will be used in analyses to assess factors which may cause savings and cost effectiveness to vary. This latter savings is based on a constant 68°F indoor temperature before and after weatherization. A change in indoor temperature is an important factor that causes performance to vary. By accounting for a change in indoor temperature in defining the savings, the effect of other factors can be better determined.

Normalized annual space-heating fuel-oil consumptions used to calculate savings for both the weatherized and control houses will be estimated from the pre- and post-weatherization data using a house energy consumption model and regression analysis to account for the following factors:

- time periods over which the data will be collected will not cover the entire winter periods,
- pre- and post-weatherization outdoor temperatures will be different and not equal to the average annual weather conditions desired for normalization, and
- indoor temperatures maintained in each house over the two periods will not be equal to the standard temperature desired for normalization.

The house energy consumption model assumes that space-heating fuel-oil consumption is linearly related to the temperature difference between the inside and outside of the house:

$$EC = A + (B * DT) , \quad (\text{Eq. 5-1})$$

where

EC = energy consumption of the space-heating system,

DT = indoor minus outdoor temperature difference,

A = intercept coefficient (determined by regression), and

B = slope coefficient (determined by regression).

Linear regression techniques will be used to estimate the parameters, A and B, for the pre- and post-weatherization periods for each house (weatherized and control) using the pre- and post-weatherization data, respectively. Weekly fuel-oil consumptions and weekly average temperature differences (average difference between hourly indoor and outdoor temperatures for the week) will be used for the primary analysis (the analysis could be performed using daily rather than weekly values if needed).

Pre- and post-weatherization normalized annual space-heating fuel-oil consumptions will be calculated using the estimated pre- and post-weatherization regression values for A and B found for each house, average outdoor temperatures from NCDC Typical Meteorological Year (TMY) weather tapes for each house location, and either the average pre- and post-weatherization indoor temperatures for each respective house or a 68°F indoor temperature. Weekly average temperature differences will be calculated using the TMY outdoor temperature data and the appropriate indoor temperature. Because positive temperature differences will result even during the summer months when no space-heating is needed, only temperature differences from selected months (perhaps September through May) will be used. Each average weekly temperature difference will then be used with values of A and B for each house to estimate a weekly space-heating fuel-oil consumption. The weekly values will be summed to obtain an estimate of the normalized annual space-heating fuel-oil consumption of each house. Normalized

annual fuel-oil savings will be found by subtracting the post-weatherization consumption from the pre-weatherization consumption.

The normalized annual fuel-oil savings of each weatherized house will be adjusted using the average normalized annual savings of the control houses to account for non-program induced factors affecting space-heating fuel-oil consumption. A procedure followed by other researchers (Fels 1986) will be used to make this adjustment. First, an adjustment factor will be calculated by dividing the average post-weatherization space-heating fuel-oil consumption of the control houses by their average pre-weatherization consumption. The adjusted savings of each weatherized house will be calculated by multiplying the pre-weatherization space-heating fuel-oil consumption by this factor and subtracting the post-weatherization consumption from this quantity.

Average regional fuel-oil savings from the WAP applied to houses heated by fuel oil will be determined using the normalized only (gross) and adjusted (net) fuel-oil savings estimated for each house (based on actual pre- and post-weatherization indoor temperatures) and the statistical equations presented in Appendix A. These equations require an accurate knowledge of the total number of houses heated by fuel oil and weatherized during the program year by the subgrantees used in the study and by all nine states. The uncertainty of the average calculated in this manner can be large because of the possibility of monitoring all large or small subgrantees and the uncertainty in knowing the number of single-family houses heated by fuel oil weatherized by each state. An alternative method of calculating the average savings for the nine states may, thus, be developed. The average savings calculated by this alternative method will be less sensitive to the number of houses heated by fuel oil and weatherized by the subgrantees and states and may have less uncertainty, although it may not be as statistically rigorous.

In some of the study houses, hot water is heated by the space-heating system. In these cases, the regression equation will be modified to account for water-heating fuel-oil consumption. This consumption will be estimated from data taken during the warmer months when there is no space heating.

5.1.2 Fuel-Oil Delivery Data

The design of the Fuel-Oil Study was based on estimating space-heating fuel-oil savings using submetered data because fuel-oil delivery data were believed to be too unavailable and unreliable for a general analysis. A fuel-oil delivery data analysis, if feasible, has the potential to provide a low-cost expansion to the study, to improve the accuracy of savings predictions, to broaden the study to include other areas of the country, and to develop a methodology for use by others in conducting similar studies. The analysis will also help provide a better basis for integrating the results from the Fuel-Oil and Single-Family Studies.

The level of usefulness of delivery data will be assessed by examining the fuel-oil delivery data collected for the 200 study houses from the 1990-1991 year. This assessment will indicate the potential benefits of using a supplemental sample of houses during the 1991-1992 winter by collecting delivery data for them. The analysis will also identify any bias that may be introduced from such an approach. The analysis will be performed before the 1991-1992 winter in order to determine if the experimental plan should be modified.

Pre-weatherization space-heating fuel-oil consumption for houses with sufficient and reliable delivery data will be determined using a degree-day approach such as the Princeton Scorekeeping Method (PRISM) (Fels 1986) and compared with the consumption estimated from submetered data to determine the degree of agreement. PRISM will use delivery data and average daily outdoor temperatures from the representative NCDC weather station from before weatherization to determine a pre-weatherization index of consumption. Fuel-oil savings cannot be estimated or compared at this time because the degree-day approaches require additional post-weatherization delivery and weather data for such an analysis.

5.2 NON-ENERGY IMPACT ANALYSIS

An assessment of program-induced improvements in the affordability of housing through reduced energy expenditures will be conducted by combining fuel expenditure data with information on household income. Fuel expenditures will be determined using the estimated fuel-oil consumptions and savings, electric billing data, and known fuel prices. The impact of the

WAP on the percent of household income spent on housing costs will be evaluated using information on rent and mortgage payments. The occupants' perception of the effect of weatherization on affordability of space-heating bills will also be evaluated.

Improvements in safety will be evaluated by determining the incidence of unsafe conditions with the space- and water-heating systems and remedial actions taken, or recommended, during weatherization. Conditions in weatherized houses will be compared with those in control houses. Occupants' perception of the effect of weatherization on the safety of their house will also be evaluated. Because houses with safety problems were sometimes excluded from the study's sample, the safety analysis will be enhanced by examining information on all houses heated by fuel oil and weatherized by the subgrantees during each program year.

Program impacts on comfort will be assessed using monitored indoor temperatures, information on the number of rooms heated, and measured air leakage of the houses. The indoor temperature data will be analyzed to determine changes in average house indoor temperatures and to develop time-of-day profiles before and after weatherization. The change in the number of rooms heated before and after weatherization will be analyzed to determine if larger areas of the house were heated and, thus, used following weatherization. The occupants' perception of the effect of weatherization on the indoor temperature of their houses will also be evaluated.

The change in airtightness of the houses will be analyzed using indicators such as air flow rate at 50 Pa pressure difference (house depressurized) across the building shell (cfm_{50}), effective leakage area (ELA), and average seasonal air exchange rate ($\text{cfm}_{\text{natural}}$). Analysis may also be performed using these indicators normalized to the total exposed surface area of the house or house volume. These indicators will be calculated from the data collected from the air-leakage tests. The airtightness of the houses before and after weatherization will be compared. Comparisons will also be made between weatherized and control houses. The occupants's perception of the effect of weatherization on the draftiness of their houses will be examined. Relationships between ECMs and air-leakage measurements will be investigated to determine the effect of packages of ECMs, the way in which they are installed, or the type of structure on which they were installed.

An air-leakage test consists of a series of air flow measurements (Q) made at pressure differences between the inside and outside of the house (dP). These data follow the power law form

$$Q = C(dP)^N \quad (\text{Eq. 5-2})$$

where C and N are constants. Because $\ln(Q)$ vs $\ln(dP)$ is a linear relation, these values will be regressed by the method of weighted least squares to determine the best values of C and N . Values of Q can then be estimated for selected values of dP . The cfm50 value will be calculated using Eq. 5-2 and 50 Pa as the value of dP .

The ELA is a recognized rating of the airtightness of the house. The ELA will be calculated using the following equation (ASHRAE 1989):

$$\text{ELA} = C_6 Q_r [p/2(dP_r)]^{0.5}/C_D \quad (\text{Eq. 5-3})$$

where

ELA	=	effective leakage area, in. ²
dP_r	=	reference pressure difference = 0.016 inches of water
Q_r	=	predicted air flow rate at dP_r , cfm
C_D	=	discharge coefficient = 1
p	=	air density, lbm/ft ³
C_6	=	unit conversion factor equal to 0.186.

The predicted air flow rate (Q_r) will be estimated using Eq. 5-2 and 4 Pa (0.016 inches of water).

The average seasonal air exchange rate will be calculated using the Lawrence Berkeley Laboratory infiltration model (ASHRAE 1989):

$$\text{cfm}_{\text{natural}} = (\text{ELA}) [(A)(dT) + (B)v^2]^{0.5} \quad (\text{Eq. 5-4})$$

where

$cfm_{natural}$	=	average seasonal air exchange rate, cfm
ELA	=	effective leakage area calculated from Eq. 5-3, in. ²
A	=	stack coefficient (ASHRAE 1989), (cfm) ² (in.) ⁻⁴ (°F) ⁻¹
dT	=	average seasonal indoor-outdoor temperature difference, °F
B	=	wind coefficient (ASHRAE 1989), (cfm) ² (in.) ⁻⁴ (mph) ⁻²
v	=	average seasonal wind speed, mph.

5.3 COST-EFFECTIVENESS ANALYSIS

The cost effectiveness of the weatherization measures alone will be examined using indicators such as simple payback period, benefit-to-cost ratio, net present value, and cost of conserved energy. The identified indicators will be calculated using standard formulas, measured fuel-oil savings, known fuel prices, and the direct labor and material costs of the ECMs. Key assumptions made in the formulas include the expected lifetime of the house and ECMs, a discount rate that reflects the time value of money, and estimated fuel-price escalation rates. Because of the uncertainty in these key assumptions, sensitivity analyses will be used to estimate a range of cost effectiveness under varying conditions.

The cost effectiveness of the WAP will be determined by expanding the previous analysis to include other program benefits and costs. A societal perspective, which estimates societal benefits achieved per public dollar spent, will be emphasized. Non-energy impacts that can be estimated in monetary terms will be incorporated into the cost-effectiveness analysis. Major benefits other than measured fuel-oil savings that may be included are:

- reducing national energy consumption;
- allowing low-income families to use a larger portion of their incomes for essential non-energy expenditures such as food, shelter, clothing, and medical care;
- improving thermal comfort and promoting healthier home environments, especially for elderly and handicapped individuals who often have special health needs;

- stimulating local economies by providing jobs and commerce in weatherization materials (i.e., indirect economic benefits); and
- maintaining or enhancing property values of dwelling units.

The indirect economic benefits will be estimated by applying an input/output method similar to the one being developed by Barry Commoner for New York State's WAP. Subgrantee and grantee costs associated with conducting the WAP will also be incorporated into the analysis.

The cost effectiveness of airtightening work will be estimated if specific costs for this work can be obtained. The fuel-oil savings of this work will be estimated using the measured reductions in air leakage, assuming that all of this reduction is due to the airtightening work (a conservative approach because reduction achieved indirectly from other measures will be credited to the airtightening work), and using equations as presented by Schlegel (1990).

5.4 ANALYSIS OF FACTORS INFLUENCING SAVINGS AND COST EFFECTIVENESS

Individual factors that may explain variations in fuel-oil savings and cost effectiveness will be examined by comparing group averages using appropriate statistical methods. Explanatory factors that will be examined include:

- pre-weatherization fuel-oil consumption, air leakage, and space-heating system efficiency;
- climate (heating degree days);
- house characteristics;
- household demographics;
- packages of ECMs installed (for example, inclusion of space-heating system measures, wall insulation, or client education);
- service delivery procedures (such as type of audit, use of contractors or in-house crews, and type of client education program);
- methods of client selection; and

- measures of technical sophistication in audit procedures and weatherization (use of blower doors and infrared scanners).

These factors will also be used with multivariate statistical models to estimate the independent influence of single variables, controlling for the influence of other factors.

The effect of different uses of a blower door (for training, locating leakage sites, or with a procedure to determine when to stop work) on the achieved air-leakage reductions and estimated cost effectiveness will be examined using methods similar to those discussed above.

5.5 MISCELLANEOUS ANALYSES

The general statistics about the characteristics of the houses studied (construction types, wall and floor areas, insulation levels, house age, etc.) and about the characteristics of the occupants will be summarized (averages and means, histograms, plots, etc.) Characteristics for the weatherized houses will be compared to those for the control houses to determine if any differences between groups existed.

Pre-weatherization steady-state efficiencies for the weatherized and control houses will be compared. Changes in efficiency due to weatherization will be determined. The effect of different space-heating system ECMs on these changes will be investigated by determining group averages or through a multivariate analysis.

6. PROJECT IMPLEMENTATION

6.1 PROJECT RESPONSIBILITIES

The WAP Evaluation Project is being carried out by ORNL at the request of the DOE WAP Division. Darrell Beschen is the DOE Project Manager. Marilyn Brown is the Project Manager at ORNL. The Fuel-Oil Study is headed by Mark Ternes of ORNL. Bill Levins will work with Mark Ternes in implementing the work. Bill Mixon, manager of ORNL's Existing Buildings Research Program, will provide advice and oversight to the Fuel-Oil Study.

The DOE WAP Division, administrators of the WAP nationally, will closely monitor the study, discuss and approve major decisions, enlist the cooperation of the states and subgrantees, assist in the dissemination of information and progress, and provide other management support as needed. This program will provide direct funding to support ORNL tasks.

Two working groups organized by the DOE WAP Division (a methodology group and a planning and implementation group) will provide DOE input on technical issues, project focus, and application of results in support of the study. They will also play a key role in the technology transfer process by helping guide the development of the evaluation and making the study results available to others.

ORNL will manage the study by conducting or coordinating all study activities. Specifically, ORNL will develop the experimental plan, develop instrumentation approaches, select subgrantees and houses, provide instrumentation, maintain a data base of all collected information, perform data analyses, and prepare a final report documenting the project and its results. ORNL will fund Synertech Systems Corporation (Synertech) and subgrantees to perform all tasks identified below except those to be funded by the State offices.

The various State offices administering the WAP at the state level will provide comments on the study design and implementation, enlist the cooperation of the subgrantees and assist in their selection, provide program information as needed (on subgrantee and grantee characteristics,

WAP approaches, costs, etc.), and help manage the study at the state level. These offices will fund subgrantees to weatherize the study houses following their standard procedure.

The subgrantees will assist in house selection, assist in instrumentation installation and maintenance, provide information on the ECMs installed and their cost, provide information on their WAP approach and costs, and administer the monetary payments to the participating households. The subgrantees will also weatherize the houses following their standard procedures during the time periods identified in this plan.

Synertech will assume the major role in implementing field related activities, in close cooperation with the subgrantees, State offices, DOE, and ORNL. These activities will include installing the supplied instrumentation; training subgrantees sufficiently to assist in instrumentation installation and maintenance; solving instrumentation problems that may arise; collecting space-heating, indoor temperature, and outdoor temperature data; collecting detailed survey data on the houses and space-heating systems; administering the occupant survey; measuring pre- and post-weatherization air leakages and space-heating system steady-state efficiencies; performing safety inspections of the space- and water-heating systems; and removing instrumentation.

6.2 PROJECT TASKS AND SCHEDULE

Project tasks and schedule through July 1991 are presented below. Similar tasks and relative schedule will be needed for the 1991-1992 winter of monitoring, but the study may be altered based on knowledge gained from the 1990-1991 winter's monitoring and decisions regarding the study design for the 1991-1992 winter.

1. Develop Experimental Plan - The experimental plan is a detailed description of the project design documenting project goals and research questions, test design and implementation, instrumentation hardware and installation, data parameters and collection methods, data analyses, participant roles, and project tasks and schedule. Due to the time constraints of the project, this plan will be developed concurrently with the implementation of the study and not finalized until November 1990.
2. Select Subgrantees and Houses - ORNL, with help and information supplied by the States and subgrantees, will select the sample of subgrantees and houses for the study in

September and October 1990. These samples will be selected following the procedures and criteria specified in Sect. 3.2. The States will provide information on subgrantees needed to make selections. Subgrantees will identify houses eligible and selected for the WAP, verify eligibility for the study, and obtain homeowner consent to participate in the study. The sizes of the samples will be based on a statistical analysis performed by ORNL (see Appendix A).

3. **Install and Maintain Instrumentation** - Synertech, with assistance from the subgrantees, will start installing the instrumentation in October 1990. Instrumentation will be provided by ORNL; specialty installation hardware will be provided by Synertech. At the time of installation, the firing rate of the space-heating system will be obtained. Synertech will train subgrantees to assist in installing and maintaining the instrumentation. The subgrantees will assist Synertech in rectifying instrumentation problems (usually by surveying a situation and installing minor replacement items) as they occur during the data collection period. Synertech will address all major instrumentation problems.
4. **Collect Pre-Weatherization Information** - Synertech will measure the air leakage and steady-state efficiency of the space-heating system of all the houses at the time instrumentation is installed. In addition, some data will be collected from the occupants during a short interview. These data will be forwarded to ORNL and maintained in a data base.
5. **Collect Field Data** - Synertech will collect telephone-transmitted data from the house instrumentation from October 1990 through June 1991 using ORNL supplied software. Synertech will assure that errorless data are received from each house. Synertech will forward these data to ORNL on a periodic basis, perhaps weekly. ORNL will maintain a data base of the collected data.
6. **Weatherize Houses** - Subgrantees will weatherize houses as identified by ORNL following their standard procedures in January 1991. It is important that all weatherization work to be performed on each house (including work funded from different sources and space-heating system improvements) be completed within a five day period to maximize the useable data collected. Thus, houses should be audited, materials purchased, and contractors identified in November and December 1990. Dates when weatherization work was started and completed must be documented for each house by the subgrantees and forwarded to ORNL or Synertech. Subgrantees will also administer the monetary payments to all participating households at this time.
7. **Collect State and Subgrantee Information** - Subgrantee characteristics, weatherization approaches, delivery procedures, ECMs installed and their costs, administration costs, and other related information will be collected by ORNL from the States and subgrantees in February 1991. ORNL will add these data to their data base of collected information.
8. **Collect Post-Weatherization Information** - Synertech will measure the air leakage and steady-state efficiency of the space-heating system of all the houses in May and June 1991. Synertech will also collect house and space-heating system information, administer an occupant survey, and assess the safety of the space- and water-heating systems at this same time. This information will be forwarded to ORNL and maintained in their data base.

9. Remove Instrumentation - Synertech will remove instrumentation from the houses and forward it to ORNL in May and June 1991. This task will be coordinated with Task 8 to increase efficiency.
10. Weatherize Control Houses - Subgrantees will weatherize control houses (houses not weatherized under Task 6) following their standard procedures starting May 1991 after instrumentation has been removed. Subgrantees will also administer the additional monetary payments to the control houses at this time.
11. Perform Interim Analysis - ORNL will perform a limited analysis of the field data to estimate annual fuel-oil consumption and savings by July 1991. The results will be used to confirm the accuracy of the study and to guide planning for the 1991-1992 winter. Also, comparisons between fuel-oil delivery data estimates and those made with the monitored house data will be made. Decisions regarding the applicability of fuel-oil delivery data to the study and use of the same or a new set of subgrantees the 1991-1992 winter will be made at this time. Plans and schedules for the 1991-1992 winter of monitoring will also be developed at this time.

7. KEY OUTCOMES

One report will be produced, describing the results of the overall study. It will address the study's four goals. The report will present an estimate of the fuel oil saved by the WAP in the Northeast during program years 1991 and 1992. Based on the proposed sample size, the estimated savings should be within about 30% of the actual savings, at a 90% confidence level.

An analysis of non-energy impacts will be presented that focuses on housing affordability, safety, and comfort. The assessment of program-induced improvements in the affordability of housing will be conducted by combining the fuel-oil cost data with information on household income and housing expenditures. Impacts on safety will be evaluated by analyzing the incidence of unsafe conditions with the space- and water-heating systems and remedial actions taken or recommended during weatherization. Safety conditions in weatherized houses will be compared with those in control houses. Monitored indoor temperatures will provide a means of assessing program impacts on comfort and will enable an assessment of any "take-back" effects. These indoor temperature data will be very important to the interpretation of the estimated region-wide fuel-oil savings and in identifying the full range of program benefits. Air-leakage test results will help to assess the program's ability to improve the airtightness of houses. Impacts on air leakage will be quantified by comparing air-leakage measurements made using a blower door before and after weatherization and in weatherized vs. control houses. Relationships between ECMs and air-leakage measurements will be investigated to determine the effect of packages of ECMs, the way in which they are installed, or the type of structure on which they were installed.

Cost effectiveness will be reported using indicators such as simple payback period, benefit-to-cost ratio, cost of conserved energy, and net present value. A sensitivity analysis of key assumptions (future fuel prices, lifetimes of the ECMs, and discount rates) will be performed.

The report will discuss factors which cause fuel-oil savings and cost effectiveness to vary. To the extent that savings and benefit-to-cost ratios vary in systematic ways, insights concerning how to best allocate WAP resources may result, so that program managers can make effective decisions. Such information can be used to identify the market segments that future program efforts should target.

8. REFERENCES

ASHRAE, 1989, Handbook of Fundamentals, American Society of Heating, Refrigerating, and Air Conditioning Engineers.

ASTM, 1987, ASTM Standard E779-87, Standard Test Method for Determining Air Leakage Rate by Fan Pressurization, The American Society for Testing and Materials.

L. G. Berry, M. A. Brown, D. L. White, and T. Wright, 1991, Evaluation Plan for the Single-Family Study, Oak Ridge National Laboratory, Draft.

D. A. Beschen and M. A. Brown, 1991, Evaluation Plan for the Weatherization Assistance Program, Oak Ridge National Laboratory, Draft.

Ecotope, 1989, Model Conservation Standards: Field Evaluation Protocol, 2812 East Madison, Seattle, Washington, July 14.

Energy Information Administration, 1989, Housing Characteristics 1987, DOE/EIA-0314 (87).

M. F. Fels, ed., 1986, "Special Issue Devoted to Measuring Energy Savings: The Scorekeeping Approach," Energy and Buildings, Vol 9, No. 1-2.

L. N. McCold, J. A. Schlegel, L. A. O'Leary, and D. C. Hewitt, 1988, Field Test Evaluation of Conservation Retrofits of Low-Income, Single-Family Buildings in Wisconsin: Audit Field Test Implementation and Results, ORNL/CON-228/P2, Oak Ridge National Laboratory, June.

J. A. Schlegel, 1990, "Blower Door Guidelines for Cost-Effective Air Sealing," Home Energy, March/April.

M. Sherman and M. Modera, 1984, Comparison of Measured and Predicted Infiltration Using the LBL Infiltration Model, LBL-17001, Lawrence Berkeley Laboratory, February.

M. Sherman et al., 1984, Variability in Residential Air Leakage, LBL-17587, Lawrence Berkeley Laboratory, April.

M. P. Ternes, P. S. Hu, L. S. Williams, and P. Goewey, 1991, The National Fuel End-Use Efficiency Field Test: Energy Savings and Performance of an Improved Energy Conservation Measure Selection Technique, ORNL/CON-303, Oak Ridge National Laboratory, January.

APPENDIX A. SAMPLING ANALYSIS

A.1 INTRODUCTION

To estimate fuel-oil savings due to weatherization performed under the WAP, the Fuel-Oil Study requires a representative sample of houses located in nine northeast states that are heated by fuel oil and weatherized by the WAP. A representative comparison group of non-weatherized houses must also be selected.

Because of the difficulty and expense of involving large numbers of subgrantees in the study and in monitoring individual houses, a cluster sampling technique is the most practical approach. A two-stage cluster sample, in which subgrantees are selected in the first stage and the houses are selected in the second stage, will be employed. The experimental design for the study involves split-winter testing over two winters (1990-1991 and 1991-1992), monitoring 125 weatherized houses and 75 control houses distributed evenly among 25 subgrantees during the 1990-1992 winter, and monitoring a different set of 125 weatherized houses and 75 control houses distributed among 25 subgrantees over the 1991-1992 winter. To ensure a representative sample, stratification by state will be employed.

Based on the analysis that follows, the accuracy of the study is maximized within the given constraints if the 25 subgrantees are distributed each winter as follows: Maine (2), New Hampshire (2), Vermont (2), Massachusetts (4), Rhode Island (2), Connecticut (2), New York (5), Pennsylvania (4), and New Jersey (2). At a 90% confidence level, the estimated savings from weatherization should be within 26-32% of the actual savings depending on which of the following options is employed. The first option draws the sample of houses from the same 25 subgrantees over the 1990-1991 and 1991-1992 winters, with a 32% relative error. The second option uses two different sets of 25 subgrantees, with a 26% relative error. In the third option, houses for the 1991-1992 winter would be sampled from half the original 25 subgrantees and from 10-15 new subgrantees.

The statistical analyses developed for the first and second options are included at the end of this Appendix (Alternative Ia and IIa, respectively). A discussion of the subgrantee

distribution selection and the estimated study accuracy follows in Sect. A.2 using the developed analyses.

A.2 DISCUSSION

The analyses were performed assuming a 20% attrition rate and using assumptions for the following variables: the variability, $S_{(w)}$, in the percentage of fuel-oil savings among low-income houses weatherized "within" a single subgrantee; the variability, $S_{s(B)}$, in the two year sum of the percent fuel-oil savings "between" subgrantees of a given state; and the variability, $S_{ls(B)}$, in the single year sum of the percent fuel-oil savings "between" subgrantees of a given state.

The variability among houses weatherized by the same subgrantee was assumed to be about 1.0 times the mean fuel-oil savings for weatherized houses. This assumption was based on two previous studies, both performed using submetered data and one also using indoor temperature data (McCold et al. 1988, Ternes et al. 1991). This assumption is consistent with the Single-Family Study, where this variability was estimated to be 1.5 times the mean energy savings for analyses using billing data (Berry et al. 1991). The assumption for the Fuel-Oil Study may actually be high because, in the two previous studies, a significant portion of the variability was due to targeting expenditures at houses within the sample that could most benefit from weatherization which will not be as prevalent in this study.

Assumptions about the variability between subgrantees in a given state were developed in several steps. First, the number of houses heated by fuel oil and weatherized each year by each subgrantee using DOE WAP funds was estimated using information provided by each state (houses are not typically categorized by type of space-heating system at the state level). The next step was to assume the following distribution of mean savings among subgrantees in each state: a third of the subgrantees would save 19%, a third would save 15%, and a third would save 11%. The final step was to apply this distribution of mean savings randomly to the distribution of houses heated by fuel oil and weatherized by each subgrantee to calculate $S_{s(B)}$ for each state using Eq. 1 from Alternative Ia and to calculate $S_{ls(B)}$ using Eq. 1 from Alternative IIa. Based on this procedure, the standard deviations estimated for the states were between 3 and 40% for $S_{s(B)}$ and between 1 and 20% for $S_{ls(B)}$.

The distribution of subgrantees among states was optimized manually using these assumptions together with Eq. 2 from both alternatives, and considering the uncertainty associated with the variables used in the equations. For the chosen distribution, the calculation of the accuracy of the study is shown in Tables A.1 and A.2

Table A.1. Calculation of the study's accuracy assuming use of the same 25 subgrantees over both the 1990-1991 and 1991-1992 winters^a

State	N_s	Sum of $M_{sc}^* = M_s^*$	Sum of $(M_{sc}^*)^2$	$S_{s(1)}$	n_s	Term in [] in Eq. 2 ^b
Connecticut	15	470	16,382	4.2898	2	2,854
Massachusetts	24	3,694	775,268	37.4774	4	219,880
Maine	11	1,619	272,499	20.0074	2	36,2752
New Hampshire	6	499	45,391	13.1968	2	3,554
New Jersey	22	583	20,589	4.9758	2	7,706
New York	74	2,390	116,874	7.6718	5	77,659
Pennsylvania	44	4,917	868,097	24.7506	4	374,534
Rhode Island	6	179	5,843	3.6528	2	333
Vermont	5	193	8,517	5.6462	2	457
Total		$M_{sc}^* = 14,544$				723,253

^aCalculations performed using the analysis presented as Alternative Ia.

^bCalculated using:

$m^* = 4$ (125 houses monitored each winter. Assuming 20% attrition leaves 100 houses for 25 subgrantees, or 4 houses per subgrantee.)

$S_{(w)} = 1.0$ $Y = 1.0 (0.15) = 0.15$, where $Y = 0.15$ (average expected savings of 15%)

Equation 2:

$$B = [(z_{\alpha/2})/M_{sc}^*] (\text{sum of the terms in []})^{0.5}$$

$$\text{using: } M_{sc}^* = 2M_s^* = 2(14,544) = 29,088$$

$$z_{\alpha/2} = 1.645 \text{ (90\% confidence level)}$$

$$B = [(1.645)/29,088] (723,253)^{0.5}$$

$$B = 0.0481$$

Then: $B/Y = 0.0481/0.15 = 32\%$

Table A.2. Calculation of the study's accuracy assuming use of a new set of subgrantees over the 1991-1992 winter^a

State	N_s	Sum of $M_{tbc} = M_{ta}$	Sum of $(M_{tbc})^2$	$S_{t/(B)}$	n_{ta}	Term in [] in Eq. 2 ^b
Connecticut	15	470	16,382	2.0449	2	2,039
Massachusetts	24	3,694	775,268	18.7387	4	135,607
Maine	11	1,619	272,499	10.0037	2	26,368
New Hampshire	6	499	45,391	6.5984	2	2,510
New Jersey	22	583	20,589	2.4879	2	4,983
New York	74	2,390	116,874	3.8359	5	47,763
Pennsylvania	44	4,917	868,097	12.3753	4	239,763
Rhode Island	6	179	5,843	1.8264	2	253
Vermont	5	193	8,517	2.8231	2	337
Total		$M_L = 14,544$				459,623

^aCalculations performed using the analysis presented as Alternative IIa.

^bCalculated using:

$m^* = 4$ (125 houses monitored each winter. Assuming 20% attrition leaves 100 houses for 25 subgrantees, or 4 houses per subgrantee.)

$S_{(w)} = 1.0 Y = 1.0 (0.15) = 0.15$, where $Y = 0.15$ (average expected savings of 15%)

Equation 2:

$$B = [(z_{\alpha/2}/M_{...}) (\text{sum of the terms in []})]^{0.5}$$

$$\text{using: } M_{...} = 2M_L = 2(14,544) = 29,088$$

$$z_{\alpha/2} = 1.645 \text{ (90\% confidence level)}$$

$$B = [(1.645)/29,088] (459,623)^{0.5}$$

$$B = 0.0383$$

Then: $B/Y = 0.0383/0.15 = 26\%$

Alternative Ia

A NATIONAL TWO-STAGE CLUSTER SAMPLING PLAN FOR THE
FUEL OIL STUDY

OUTLINE OF PROPOSAL

I. INTRODUCTION, SETTING, POPULATION, OBJECTIVES, NOTATION

We can describe the population in terms of levels.

Level 1. Fuel Oil WAP Northeast Population

Let $M_{...}$ = the number of home units weatherized in the Northeast by WAP in 1991 and 1992.

Level 2. States

There are nine states in the Northeast which contain the population of home units for the Fuel Oil Study. They are:

- | | | |
|------------------|------------------|-----------------|
| 1. Maine | 4. Massachusetts | 7. New York |
| 2. New Hampshire | 5. Rhode Island | 8. Pennsylvania |
| 3. Vermont | 6. Connecticut | 9. New Jersey |

Let $M_{s..}$ = the number of home units in the s^{th} state where
 $s = 1, 2, 3, \dots, 9$.

Thus $M_{1..}$ = the number of home units in the 1st state.

$M_{2..}$ = the number of home units in the 2nd state.

⋮

$M_{9..}$ = the number of home units in the 9th state.

Note: $M_{...} = M_{1..} + M_{2..} + \dots + M_{9..}$

Level 3. CAPS

Each state consists of CAPS which coordinate the WAP for the home units in that state.

Let $M_{sc.}$ = the number of home units in the c^{th} CAP for the s^{th} state
where $c = 1, 2, \dots, N_s$.

Note: $N_s = N_{s1} + N_{s2} + \dots + N_{sN_s}$ is the total number of CAPS.

Level 4. Stratification of Each CAP Into Years

Each CAP is partitioned into a stratum (1) of home units weatherized in the 1st year and a stratum (2) of home units weatherized in the 2nd year by WAP.

Let M_{sct} = the number of home units weatherized by WAP in year t in the c^{th} CAP of the s^{th} state where $t = 1$ (1st year) and $t = 2$ (2nd year).

Thus M_{sc1} = the number of home units weatherized by WAP in the 1st year in the c^{th} CAP of the s^{th} state, and

M_{sc2} = the number of home units weatherized by WAP in the 2nd year in the c^{th} CAP of the s^{th} state.

Note: $M_{sc} = M_{sc1} + M_{sc2}$.

An overview of the four levels is given in Figure 1.

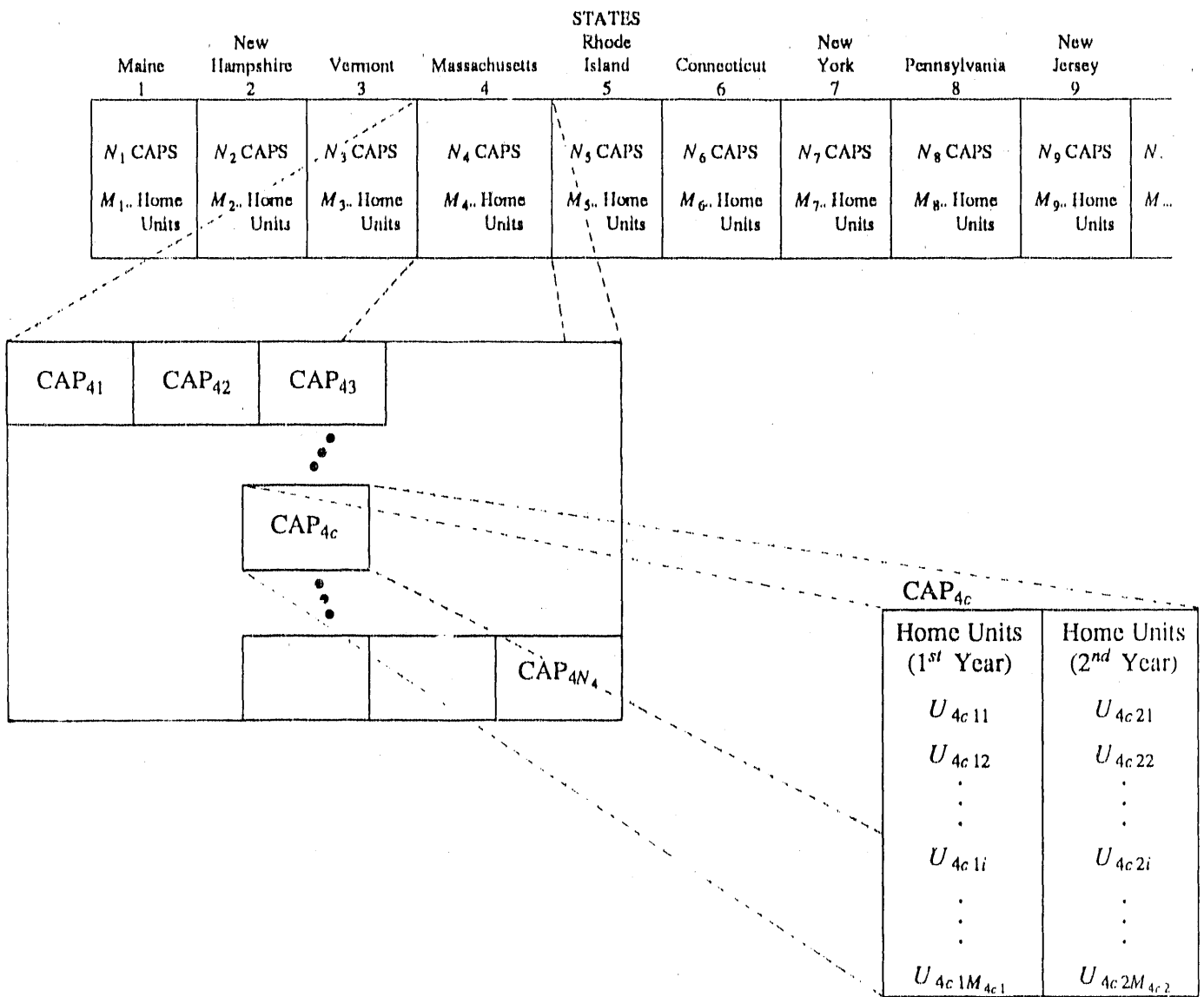

Figure 1.

Let Y_{scti} = the percent energy savings for the i^{th} home unit in the t^{th} year in the c^{th} CAP of the s^{th} state.

Then we have the following (unknown) totals and means:

$$Y_{sct.} = \sum_{i=1}^{M_{sct}} Y_{scti} = \text{the total percent energy savings for the home units weatherized by WAP in the } t^{th} \text{ year in the } c^{th} \text{ CAP of the } s^{th} \text{ state.}$$

$$Y_{sc..} = Y_{sc1.} + Y_{sc2.} = \text{the total percent energy saving for the home units weatherized by WAP in both years in the } c^{th} \text{ CAP of the } s^{th} \text{ state.}$$

$$Y_{s...} = \sum_{c=1}^{N_s} Y_{sc..} = \text{the total percent energy savings for the home units weatherized by WAP in both years in the } s^{th} \text{ state.}$$

$$\bar{Y}_s = \frac{Y_{s...}}{M_{s...}} = \text{the average (mean) percent energy savings per home unit in the } s^{th} \text{ state over both years.}$$

$$Y_{....} = \sum_{s=1}^9 Y_{s...} = \text{the total percent energy savings for the } M_{....} \text{ home units weatherized by WAP in both years in the Northeast WAP.}$$

Finally,

$$\bar{Y} = \frac{Y_{....}}{M_{....}} = \text{the average (mean) percent energy savings per home unit for WAP over both years.}$$

The primary objective is to estimate \bar{Y} based on a sample of home units weatherized by WAP over both years.

II. STRATIFIED TWO-STAGE CLUSTER (STRATIFIED) SAMPLING PLAN

Step 1. As we saw earlier, there are 9 strata as given below. Lower case m and n refer to sample sizes.

STATES									
1	2	3	4	5	6	7	8	9	
n_1 CAPS	n_2 CAPS	n_3 CAPS	n_4 CAPS	n_5 CAPS	n_6 CAPS	n_7 CAPS	n_8 CAPS	n_9 CAPS	n .
$m_{1..}$ Home Units	$m_{2..}$ Home Units	$m_{3..}$ Home Units	$m_{4..}$ Home Units	$m_{5..}$ Home Units	$m_{6..}$ Home Units	$m_{7..}$ Home Units	$m_{8..}$ Home Units	$m_{9..}$ Home Units	$m_{...}$

Step 2.

Stage 1. Within stratum "s" and independently of the other strata, select a simple random sample of n_s caps. We will have

$$CAP_{s1}, CAP_{s2}, \dots, CAP_{sc}, \dots, CAP_{sn_s}$$

Note here that $c = 1, 2, \dots, n_s$. We do this 9 independent times. The total number of CAPS selected is

$$n = n_1 + n_2 + \dots + n_9.$$

Stage 2. For the c^{th} selected CAP from stratum s in Stage 1, select a simple random sample of m_{sc1} home units weatherized by WAP in the first year and independently select a simple random sample of m_{sc2} home units weatherized by WAP in the second year.

We will have

$t = 1$	$t = 2$
u_{sc11}	u_{sc21}
u_{sc12}	u_{sc22}
⋮	⋮
⋮	⋮
u_{sc1i}	u_{sc2i}
⋮	⋮
⋮	⋮
$u_{sc1m_{sc1}}$	$u_{sc2m_{sc2}}$

Note:

$m_{sc} = m_{sc1} + m_{sc2}$ = the total number of home units weatherized by WAP in both years selected from the c^{th} sample CAP from state s .

$m_{s..} = \sum_{c=1}^{n_s} m_{sc}$ = the total number of home units weatherized by WAP in both years selected from state s .

$m_{...} = \sum_{s=1}^9 m_{s..}$ = the total number of sample home units weatherized by WAP in both years.

III. ESTIMATION OF THE TOTALS AND \bar{Y} .

1. We have the following sample statistics for the c^{th} selected CAP from stratum (state) s .

1.1 \bar{y}_{sc1} – sample mean percent energy savings for home units weatherized by WAP in 1st year.

s_{sc1}^2 – sample variance for the percent energy savings for home units weatherized by WAP in 1st year.

$\hat{Y}_{sc1} = M_{sc1} \bar{y}_{sc1}$ = an estimate of the total percent energy savings for home units weatherized by WAP in the 1st year for the c^{th} selected CAP from stratum s .

1.2 \bar{y}_{sc2} – sample mean percent energy savings for home units weatherized by WAP in 2nd year.

s_{sc2}^2 – sample variance for the percent energy savings for home units weatherized by WAP in 2nd year.

$\hat{Y}_{sc2} = M_{sc2}\bar{y}_{sc2}$ = an estimate of the total percent energy savings for home units weatherized by WAP in the 2nd year for the c^{th} selected CAP from stratum s .

$$2. \hat{Y}_{sc..} = \hat{Y}_{sc1.} + \hat{Y}_{sc2.}$$

$$Var(\hat{Y}_{sc..}) = M_{sc1}^2 \left(\frac{M_{sc1} - m_{sc1}}{M_{sc1}} \right) \frac{s_{sc1}^2}{m_{sc1}} + M_{sc2}^2 \left(\frac{M_{sc2} - m_{sc2}}{M_{sc2}} \right) \frac{s_{sc2}^2}{m_{sc2}}$$

and

$$\hat{Var}(\hat{Y}_{sc..}) = M_{sc1}^2 \left(\frac{M_{sc1} - m_{sc1}}{M_{sc1}} \right) \frac{S_{sc1}^2}{m_{sc1}} + M_{sc2}^2 \left(\frac{M_{sc2} - m_{sc2}}{M_{sc2}} \right) \frac{S_{sc2}^2}{m_{sc2}}$$

Note that S_{sc1}^2 and S_{sc2}^2 are "population variances" for the strata in the c^{th} CAP and s_{sc1}^2 and s_{sc2}^2 are the corresponding "sample variances" as defined above.

3. An estimator of $Y_{s...}$, the total percent energy savings for the home units weatherized by WAP in both years in the s^{th} state is

$$\hat{Y}_{s...} = \frac{N_s}{n_s} \sum_{c=1}^{n_s} \hat{Y}_{sc..} \quad (\text{See Cochran, page 303, (11.21).})$$

with sampling variance

$$Var(\hat{Y}_{s...}) = N_s^2 \left(\frac{N_s - n_s}{N_s} \right) \frac{S_s^2(B)}{n_s} + \frac{N_s}{n_s} \sum_{c=1}^{n_s} Var(\hat{Y}_{sc..})$$

$$\text{where } S_s^2(B) = \frac{\sum_{c=1}^{n_s} (Y_{sc..} - \bar{Y}_s)^2}{N_s - 1} \quad \text{and } \bar{Y}_s = \frac{Y_{s...}}{N_s} \quad (\text{Eq. 1})$$

and the estimated sampling variance

$$\hat{Var}(\hat{Y}_{s...}) = N_s^2 \left(\frac{N_s - n_s}{N_s} \right) \frac{s_s^2(B)}{n_s} + \frac{N_s}{n_s} \sum_{c=1}^{n_s} \hat{Var}(\hat{Y}_{sc..})$$

$$\text{where } s_s^2(B) = \frac{\sum_{c=1}^{n_s} (\hat{Y}_{sc..} - \hat{Y}_s)^2}{n_s - 1} \quad \text{and } \hat{Y}_s = \frac{\sum_{c=1}^{n_s} \hat{Y}_{sc..}}{n_s}$$

4. An estimator of $Y_{...}$, the total percent energy savings for the $M_{...}$ home units weatherized by WAP in both years, is

$$\hat{Y}_{...} = \sum_{s=1}^9 \hat{Y}_{s...}$$

with sampling variance

$$\text{Var}(\hat{Y}_{...}) = \sum_{s=1}^9 \text{Var}(\hat{Y}_{s...})$$

and estimated sampling variance

$$\hat{\text{Var}}(\hat{Y}_{...}) = \sum_{s=1}^9 \hat{\text{Var}}(\hat{Y}_{s...})$$

5. Finally, an estimator of \bar{Y} , the average percent energy savings per home unit weatherized by WAP during the two-year period, is

$$\hat{\bar{Y}} = \frac{\hat{Y}_{...}}{M_{...}}$$

with sampling variance

$$\text{Var}(\hat{\bar{Y}}) = \frac{1}{M_{...}^2} \text{Var}(\hat{Y}_{...})$$

and estimated sampling variance

$$\hat{\text{Var}}(\hat{\bar{Y}}) = \frac{1}{M_{...}^2} \hat{\text{Var}}(\hat{Y}_{...})$$

(From 3, we can produce an estimate of \bar{Y}_s .)

IV. SAMPLE SIZES

The desire is to determine n , the total number of CAPS to be selected for the sample and $m_{...}$ the total number of home units weatherized by WAP in both years to be selected at the second stage so that $\hat{\bar{Y}}$ is within B of \bar{Y} with probability $1 - \alpha$. Assuming that $\hat{\bar{Y}}$ is normally distributed, we have

$$B = Z_{\frac{\alpha}{2}} \sqrt{\text{Var}(\hat{\bar{Y}})} = \frac{Z_{\frac{\alpha}{2}}}{M_{...}} \sqrt{\text{Var}(\hat{Y}_{...})}$$

Thus

$$\begin{aligned}
 (M \dots)B &= Z_{\frac{\alpha}{2}} \sqrt{\widehat{\text{Var}}(Y \dots)} \\
 \Rightarrow (M \dots)B &= Z_{\frac{\alpha}{2}} \sqrt{\sum_s \widehat{\text{Var}}(Y_s \dots)} \\
 \Rightarrow (M \dots)B &= Z_{\frac{\alpha}{2}} \sqrt{\sum_s \left[N_s^2 \left(\frac{N_s - n_s}{N_s} \right) \frac{S_s^2(B)}{n_s} + \frac{N_s}{n_s} \sum_{c=1}^{N_s} \widehat{\text{Var}}(Y_{sc \dots}) \right]} \\
 \Rightarrow (M \dots)B &= Z_{\frac{\alpha}{2}} \left(\sum_s \left[N_s^2 \left(\frac{N_s - n_s}{N_s} \right) \frac{S_s^2(B)}{n_s} + \frac{N_s}{n_s} \sum_{c=1}^{N_s} \left\{ M_{sc1}^2 \left(\frac{M_{sc1} - m_{sc1}}{M_{sc1}} \right) \frac{S_{sc1}^2}{m_{sc1}} \right. \right. \right. \\
 &\quad \left. \left. \left. + M_{sc2}^2 \left(\frac{M_{sc2} - m_{sc2}}{M_{sc2}} \right) \frac{S_{sc2}^2}{m_{sc2}} \right\} \right] \right)^{1/2}
 \end{aligned}$$

For all CAPS, assume $M_{sc1} = M_{sc2} = M_{sc}^*$ and $S_{sc1}^2 = S_{sc2}^2 = S_{sc}^2 = S_{(w)}^2$. Also for all CAPS, let $m_{sc1} = m_{sc2}$ be the same value m^* . Thus the above equation becomes

$$\begin{aligned}
 (M \dots)B &= Z_{\frac{\alpha}{2}} \sqrt{\sum_s \left[N_s^2 \left(\frac{N_s - n_s}{N_s} \right) \frac{S_s^2(B)}{n_s} + \frac{2N_s}{n_s} \sum_{c=1}^{N_s} (M_{sc}^*)^2 \left(\frac{M_{sc}^* - m^*}{M_{sc}^*} \right) \frac{S_{(w)}^2}{m^*} \right]} \\
 &= Z_{\frac{\alpha}{2}} \sqrt{\sum_s \left[N_s^2 \left(\frac{N_s - n_s}{N_s} \right) \frac{S_s^2(B)}{n_s} + \frac{2N_s}{n_s} \frac{S_{(w)}^2}{m^*} \left\{ \sum_{c=1}^{N_s} (M_{sc}^*)^2 - m^* \sum_{c=1}^{N_s} M_{sc}^* \right\} \right]} \quad (\text{Eq. 2})
 \end{aligned}$$

Alternative IIa

A NATIONAL TWO-STAGE CLUSTER SAMPLING PLAN FOR
THE FUEL OIL STUDY

OUTLINE OF PROPOSAL

I. INTRODUCTION, SETTING, POPULATION, OBJECTIVES, NOTATION

We can describe the population in terms of levels.

Level 1. Fuel Oil WAP Northeast Population Over Two Winters

Let $M_{...}$ = the number of home units using fuel oil weatherized in the Northeast by WAP in 1991 and 1992.

Level 2. Years

Some home units in the population will be weatherized in 1991 and the remaining population units will be weatherized in 1992. To distinguish between years, let

$M_{t..}$ = the number of home units using fuel oil weatherized in the Northeast by WAP in year t , where $t = 1$ for 1991 and $t = 2$ for 1992.

Note: $M_{...} = M_{1..} + M_{2..}$ where

$M_{1..}$ = the number of home units weatherized in 1991 for $t=1$, and

$M_{2..}$ = the number of home units weatherized in 1992 for $t=2$.

Level 3. States

For each winter, there will be nine states in the Northeast which will contain the population of home units for the Fuel Oil Study. They are:

- | | | |
|------------------|------------------|-----------------|
| 1. Maine | 4. Massachusetts | 7. New York |
| 2. New Hampshire | 5. Rhode Island | 8. Pennsylvania |
| 3. Vermont | 6. Connecticut | 9. New Jersey |

Let $M_{t,s}$ = the number of home units in the s^{th} state (where $s = 1, 2, 3, \dots, 9$) of the t^{th} winter.

Thus $M_{t,1}$ = the number of home units in the 1st state of the t^{th} winter.

⋮

$M_{t,9}$ = the number of home units in the 9th state of the t^{th} winter.

Note: $M_{t..} = M_{t,1} + M_{t,2} + \dots + M_{t,9}$.

Level 4. CAPS

For each winter, each state consists of CAPS which coordinate the WAP for the home units in that state.

Let M_{tsc} = the number of home units in the c^{th} CAP for the s^{th} state for the t^{th} winter where $c = 1, 2, \dots, N_{ts}$.

Note: $N_{t.} = N_{t1} + N_{t2} + \dots + N_{t9}$ and $N_{..} = N_{.1} + N_{.2}$.

An overview of the four levels is given in Figure 1.

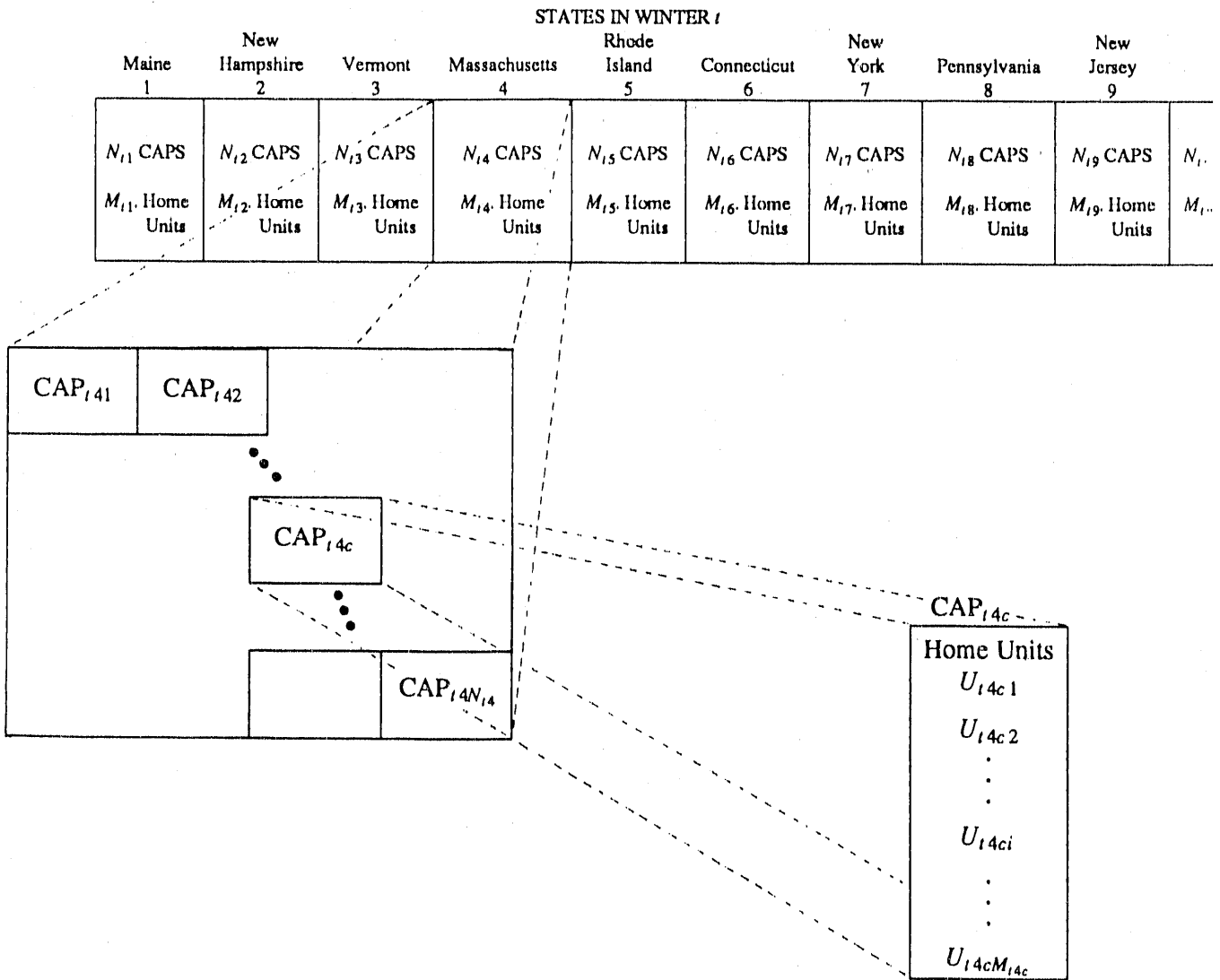

Figure 1.

We continue with the following notation. Within winter t , let

Y_{tsci} = the percent energy savings for the i^{th} home unit in the c^{th} CAP of the s^{th} state for winter t .

Then we have the following (unknown) totals and means:

$Y_{tsc} = \sum_{i=1}^{M_{tsc}} Y_{tsci}$ = the total percent energy savings for the home units in the c^{th} CAP of the s^{th} state for winter t .

$Y_{ts..} = \sum_{c=1}^{N_u} Y_{tsc}$ = the total percent energy savings for the home units in the s^{th} state for winter t .

$\bar{Y}_{ts} = \frac{Y_{ts..}}{M_{ts}}$ = the average percent energy savings per home unit in the s^{th} state for winter t .

$Y_{t...} = \sum_{s=1}^9 Y_{ts..}$ = the total percent energy savings for the $M_{t...}$ home units in the Northeast WAP for winter t .

$\bar{Y}_t = \frac{Y_{t...}}{M_{t...}}$ = the average percent energy savings per home unit for WAP during winter t .

$Y_{...} = Y_{1...} + Y_{2...}$ = the total percent energy saving for the $M_{...}$ home units in the Northeast WAP over both winters.

Finally,

$\bar{Y} = \frac{Y_{...}}{M_{...}}$ = the average percent energy savings per home unit for WAP for the two winters.

The primary objective is to estimate \bar{Y} based on a sample.

II. STRATIFIED TWO-STAGE CLUSTER SAMPLING PLAN

Step 1. As we saw earlier, there are 9 strata (states) for each winter as given below. Lower case m and n refer to sample sizes.

STATES IN WINTER t									
1	2	3	4	5	6	7	8	9	
n_{t1} CAPS	n_{t2} CAPS	n_{t3} CAPS	n_{t4} CAPS	n_{t5} CAPS	n_{t6} CAPS	n_{t7} CAPS	n_{t8} CAPS	n_{t9} CAPS	$n_{t.}$
m_{t1} . Home Units	m_{t2} . Home Units	m_{t3} . Home Units	m_{t4} . Home Units	m_{t5} . Home Units	m_{t6} . Home Units	m_{t7} . Home Units	m_{t8} . Home Units	m_{t9} . Home Units	$m_{t.}$

Step 2.

Stage 1. For winter t and within stratum " s " and independently of the other strata (there are eighteen strata altogether over the two winters), select a simple random sample of n_{ts} CAPS. We will have

$$CAP_{ts1}, CAP_{ts2}, \dots, CAP_{tsc}, \dots, CAP_{tsn_{ts}}$$

Note here that $c = 1, 2, \dots, n_{ts}$. We do this 18 independent times. The total number of CAPS selected for the two winters is

$$\begin{aligned} n_{..} &= n_{1.} + n_{2.} \\ &= (n_{11} + n_{12} + \dots + n_{19}) + (n_{21} + n_{22} + \dots + n_{29}). \end{aligned}$$

Stage 2. For the t^{th} winter and for the c^{th} selected CAP from stratum ts in Stage 1, select a simple random sample of m_{tsc} home units. We will have

$$\begin{aligned} &u_{tsc1} \\ &u_{tsc2} \\ &\vdots \\ &u_{tsci} \\ &\vdots \\ &u_{tscm_{tsc}} \end{aligned}$$

Note:

m_{tsc} = the total number of home units selected from the c^{th} sample CAP from stratum s for winter t .

$m_{ts.} = \sum_{c=1}^{n_{ts}} m_{tsc}$ = the total number of home units selected from state s for winter t .

$m_{t..} = \sum_{s=1}^9 m_{ts.}$ = the total number of sample home units for winter t .

$m_{..} = m_{1..} + m_{2..}$ = the total number of sample home units over the two winters.

III. ESTIMATION OF THE TOTALS AND \bar{Y} .

1. We have the following sample statistics for the c^{th} selected CAP from stratum ts .

\bar{y}_{tsc} - sample mean percent energy savings for home units.

s_{tsc}^2 - sample variance for the percent energy savings for home units.

$\hat{Y}_{tsc.} = M_{tsc} \bar{y}_{tsc}$ = an estimate of the total percent energy savings for home units for the c^{th} selected CAP from stratum ts .

$$\text{Var}(\hat{Y}_{tsc.}) = M_{tsc}^2 \left(\frac{M_{tsc} - m_{tsc}}{M_{tsc}} \right) \frac{S_{tsc}^2}{m_{tsc}}$$

and

$$\hat{V}ar(\hat{Y}_{isc.}) = M_{isc}^2 \left(\frac{M_{isc} - m_{isc}}{M_{isc}} \right) \frac{S_{isc}^2}{m_{isc}}$$

Note that S_{isc}^2 is a "population variance" for the c^{th} CAP and s_{isc}^2 is the corresponding "sample variance" defined above.

2. An estimator of $Y_{is..}$ is

$$\hat{Y}_{is..} = \frac{N_{is}}{n_{is}} \sum_{c=1}^{n_{is}} \hat{Y}_{isc.} \quad (\text{See Cochran, page 303, (11.21).})$$

with sampling variance

$$Var(\hat{Y}_{is..}) = N_{is}^2 \left(\frac{N_{is} - n_{is}}{N_{is}} \right) \frac{S_{is(B)}^2}{n_{is}} + \frac{N_{is}}{n_{is}} \sum_{c=1}^{n_{is}} Var(\hat{Y}_{isc.})$$

$$\text{where } S_{is(B)}^2 = \frac{\sum_{c=1}^{n_{is}} (Y_{isc.} - \bar{Y}_{is})^2}{N_{is} - 1} \quad \text{and} \quad \bar{Y}_{is} = \frac{Y_{is..}}{N_{is}} \quad (\text{Eq. 1})$$

and the estimated sampling variance

$$\hat{V}ar(\hat{Y}_{is..}) = N_{is}^2 \left(\frac{N_{is} - n_{is}}{N_{is}} \right) \frac{s_{is(B)}^2}{n_{is}} + \frac{N_{is}}{n_{is}} \sum_{c=1}^{n_{is}} \hat{V}ar(\hat{Y}_{isc.})$$

$$\text{where } s_{is(B)}^2 = \frac{\sum_{c=1}^{n_{is}} (\hat{Y}_{isc.} - \hat{\bar{Y}}_{is})^2}{n_{is} - 1} \quad \text{and} \quad \hat{\bar{Y}}_{is} = \frac{\sum_{c=1}^{n_{is}} \hat{Y}_{isc.}}{n_{is}}$$

3. An estimator of $Y_{l...}$ is

$$\hat{Y}_{l...} = \sum_{s=1}^9 \hat{Y}_{ls..}$$

with sampling variance

$$Var(\hat{Y}_{l...}) = \sum_{s=1}^9 Var(\hat{Y}_{ls..})$$

and estimated sampling variance

$$\hat{V}ar(\hat{Y}_{l...}) = \sum_{s=1}^9 \hat{V}ar(\hat{Y}_{ls..})$$

4. An estimator of \bar{Y}_l is

$$\hat{\bar{Y}}_l = \frac{\hat{Y}_{l...}}{M_{l..}}$$

with sampling variance

$$\text{Var}(\hat{\bar{Y}}_l) = \frac{1}{M_{l...}^2} \text{Var}(\hat{Y}_{l...})$$

and estimated sampling variance

$$\text{Var}(\hat{\bar{Y}}_l) = \frac{1}{M_{l...}^2} \hat{\text{Var}}(\hat{Y}_{l...})$$

5. An estimator of $Y_{...}$ is

$$\hat{Y}_{...} = \hat{Y}_{1...} + \hat{Y}_{2...}$$

with sampling variance

$$\text{Var}(\hat{Y}_{...}) = \text{Var}(\hat{Y}_{1...}) + \text{Var}(\hat{Y}_{2...})$$

and estimated sampling variance

$$\hat{\text{Var}}(\hat{Y}_{...}) = \hat{\text{Var}}(\hat{Y}_{1...}) + \hat{\text{Var}}(\hat{Y}_{2...})$$

6. Finally, an estimator of \bar{Y} is

$$\hat{\bar{Y}} = \frac{\hat{Y}_{...}}{M_{...}}$$

with sampling variance

$$\text{Var}(\hat{\bar{Y}}) = \frac{1}{M_{...}^2} \text{Var}(\hat{Y}_{...})$$

and estimated sampling variance

$$\hat{\text{Var}}(\hat{\bar{Y}}) = \frac{1}{M_{...}^2} \hat{\text{Var}}(\hat{Y}_{...})$$

IV. SAMPLE SIZES

The desire is to determine $n_{...}$ the total number of CAPS to be selected for the sample over the two winters and $m_{...}$ the total number of home units to be selected at the second stage for the two winters so that $\hat{\bar{Y}}$ is within B of \bar{Y} with probability $1 - \alpha$. Assuming that $\hat{\bar{Y}}$ is normally distributed, we have

$$B = Z_{\frac{\alpha}{2}} \sqrt{\text{Var}(\hat{\bar{Y}})} = \frac{Z_{\frac{\alpha}{2}}}{M_{...}} \sqrt{\text{Var}(\hat{Y}_{...})}$$

Thus

$$(M \dots)B = Z_{\frac{\alpha}{2}} \sqrt{\widehat{\text{Var}}(Y \dots)}$$

$$\Rightarrow (M \dots)B = Z_{\frac{\alpha}{2}} \sqrt{\sum_{i,s} \widehat{\text{Var}}(Y_{i,s})}$$

$$\Rightarrow (M \dots)B = Z_{\frac{\alpha}{2}} \sqrt{\sum_{i,s} \left[N_{i,s}^2 \left(\frac{N_{i,s} - n_{i,s}}{N_{i,s}} \right) \frac{S_{i,s}^2(B)}{n_{i,s}} + \frac{N_{i,s}}{n_{i,s}} \sum_{c=1}^{N_{i,s}} \widehat{\text{Var}}(Y_{i,s,c}) \right]}$$

$$\begin{aligned} \Rightarrow (M \dots)B &= Z_{\frac{\alpha}{2}} \sqrt{\sum_{i,s} \left[N_{i,s}^2 \left(\frac{N_{i,s} - n_{i,s}}{N_{i,s}} \right) \frac{S_{i,s}^2(B)}{n_{i,s}} + \frac{N_{i,s}}{n_{i,s}} \sum_{c=1}^{N_{i,s}} \left\{ M_{i,s,c}^2 \left(\frac{M_{i,s,c} - m_{i,s,c}}{M_{i,s,c}} \right) \frac{S_{i,s,c}^2}{m_{i,s,c}} \right\} \right]} \\ &= Z_{\frac{\alpha}{2}} \sqrt{\sum_{i,s} \left[N_{i,s}^2 \left(\frac{N_{i,s} - n_{i,s}}{N_{i,s}} \right) \frac{S_{i,s}^2(B)}{n_{i,s}} + \frac{N_{i,s}}{n_{i,s}} \sum_{c=1}^{N_{i,s}} M_{i,s,c} \left(\frac{M_{i,s,c} - m_{i,s,c}}{M_{i,s,c}} \right) \frac{S_{i,s,c}^2}{m_{i,s,c}} \right]} \end{aligned}$$

Assuming all $S_{i,s,c}^2 = S_{(w)}^2$, and $m_{i,s,c} = m^*$ the same, the equation becomes

$$\begin{aligned} (M \dots)B &= Z_{\frac{\alpha}{2}} \sqrt{\sum_{i,s} \left[N_{i,s}^2 \left(\frac{N_{i,s} - n_{i,s}}{N_{i,s}} \right) \frac{S_{i,s}^2(B)}{n_{i,s}} + \frac{N_{i,s}}{n_{i,s}} \frac{S_{(w)}^2}{m^*} \left\{ \sum_{c=1}^{N_{i,s}} M_{i,s,c}^2 - m^* \sum_{c=1}^{N_{i,s}} M_{i,s,c} \right\} \right]} \\ &= Z_{\frac{\alpha}{2}} \sqrt{\sum_{i,s} \left[N_{i,s}^2 \left(\frac{N_{i,s} - n_{i,s}}{N_{i,s}} \right) \frac{S_{i,s}^2(B)}{n_{i,s}} + \frac{N_{i,s}}{n_{i,s}} \frac{S_{(w)}^2}{m^*} \left\{ \sum_{c=1}^{N_{i,s}} M_{i,s,c}^2 - m^* M_{i,s} \right\} \right]} \quad (\text{Eq. 2}) \end{aligned}$$

APPENDIX B. HOUSE SCREENING CHECKLIST

The house screening checklist will be used by the subgrantees to verify that the houses meet the eligibility requirements for the study listed in Sect. 3.3. In some cases, the occupants will sign the checklist to verify their agreement to participate in the study.

HOUSE SCREENING CHECKLIST: FUEL-OIL STUDY PARTICIPANTS

Name: _____ Phone number: _____

Address: _____

Questions needing a "yes" answer

Yes

No

Is the household eligible for the Weatherization Assistance Program as administered by your organization?

Is the home a single-family house but not a mobile home or similar manufactured building (refer to attached description)?

Is fuel oil used as the primary energy source to heat the house?

Is there an operating telephone located in the house?

Questions needing a "no" answer

Do the occupants have any plans to move or be away from the house for an extended time period between October 1990 and May 1991 (absences of 1-2 weeks are acceptable)?

Is a secondary fuel (such as wood) or heating system (such as portable kerosene or electric heaters) used more than one day per week to heat areas other than the bathrooms?

If questions needing a "yes" answer are answered yes and the "no" questions are answered no, the house is eligible for the study.

Is this house eligible for the study?

Agency: _____

Completed by: _____ Date: _____

SINGLE-FAMILY BUILDING DEFINITION

For the Fuel-Oil Study, houses must be single-family buildings but not mobile homes or other similar housing assembled on-site from factory built modules. Single-family buildings are defined as follows:

"A single-family housing unit is a structure that provides living space for one household or family. The structure may be detached, attached on one side (semidetached), or attached on two sides. Attached houses are considered single-family houses as long as the house itself is not divided into more than one housing unit and has an independent outside entrance. A single-family house is contained within walls that go from the basement (or the ground floor, if there is no basement) to the roof."

In adherence to this definition, row houses and side-by-side duplexes (twins) are single-family houses, whereas over-and-under duplexes are multifamily (see definition below). Although a mobile home with one or more rooms added is often classified as a single-family house, it will not be considered single-family for this study.

Small multifamily buildings are defined as follows:

"A house or building with two to four housing units is a structure that is divided into living quarters for two, three, or four families or households. This category also includes houses originally intended for occupancy by one family (or for some other use) that have since been converted to separate dwellings for two to four families. Typical arrangements in these types of living quarters are separate apartments downstairs and upstairs, or one apartment on each of three or four floors."

APPENDIX C. INSTRUMENTATION LITERATURE

Literature on the Telog model R-2400 data logger, Infiltec blower door, and Lynn model 6500B analyzer are enclosed.

R-2400

Automated Data Acquisition and Communications System



Introducing ...

The R-2400 Series Recorders from Telog Instruments -

a data acquisition system with flexibility and power that is unprecedented in its price range.

Automation, Flexibility and Simplicity

The R-2400 Series Recorders can process a variety of analog inputs: voltage, current loop, ambient temperature, events and pulses, RTDs, thermocouples, scalar wind direction, potentiometers, and pressure strain gages. Under your programming control, the R-2400 Series Recorder will automatically perform any necessary signal conditioning, convert the conditioned signal into digital form, process and store the data, and transfer historical data to your computer. You have many options in the placement and interrogation of your recorders, as well as the collection and presentation of the recorded data.

The rugged, rainproof R-2400 Series Recorder is battery-operated and will faithfully carry out your program commands for months at a time. The samples collected are stored in memory and the historical data can be transferred to your computer in variety of ways: via modem over common voice-grade telephone lines, through a Local Area Network (TeLAN), or by manual collection on site with the Telog Data Transfer Unit.

Comprehensive Support Software

Telog Instruments helps you harness the power of computer technology without needing extensive programming experience. The R-2400 Software Support package uses pulldown menus (with on-line help) that make it easy to design data collection schedules, communicate with recorders, analyze data and generate reports - all with just the press of a few buttons.

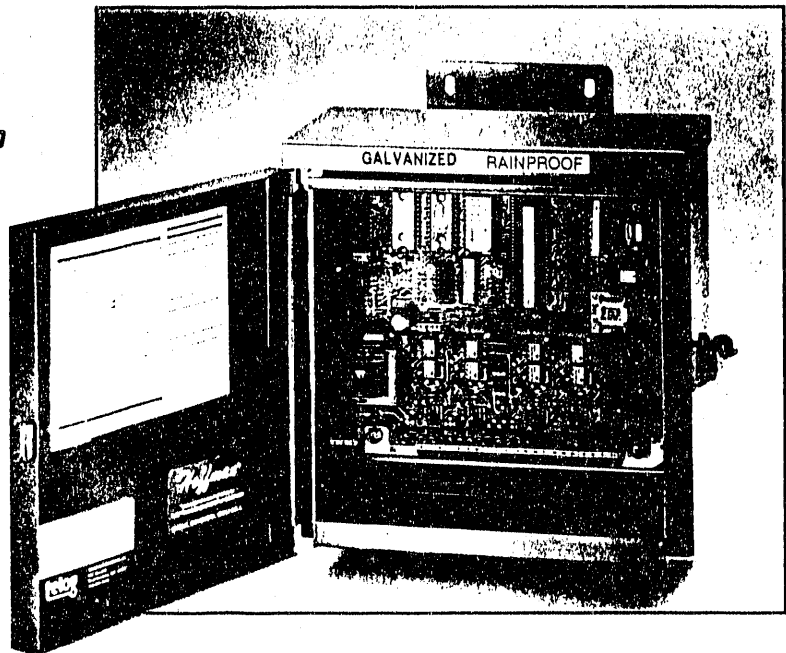

Features

- **Stores up to 12,800 data values in each recorder unit**
- **Automated data collection**
- **Built-in modem**
- **Local area network capabilities**
- **Can monitor a variety of analog inputs**
- **User programmable**
- **Interfaces with IBM-compatible personal computers**
- **Easy-to-use menu-driven software with on-line help**
- **Report-ready hard copies**

R-2400

From the field ... to your

Automatic, Fast and Reliable Data Transmission

Each recorder works independently in the field but their activities are directed by Telog R-2400 Support Software. All you do is choose the most convenient of three ways to accomplish the task: modem, local area network or direct field data collection. Whatever your choice, data collection is efficient and accurate. From the R-2400 Series Recorder to your computer, there is no chance for transmission errors; all communications with recorders use an error detection and retransmission algorithm to ensure error-free data transfer.

Built-in Modem

The R-2400 Series Recorder uses low cost common voice-grade telephone lines for automatic data transmission. No special leased line is required. The 300-baud modem makes possible two-way communications between you and your recorder in the field, eliminating the need to visit installation sites. From your office computer, you can check on the current real-time readings and update the recorder. In the field, the recorder can be programmed to call your office computer automatically - at scheduled times, preset alarm conditions, two hours after an AC power failure or when their memory is 80% full.

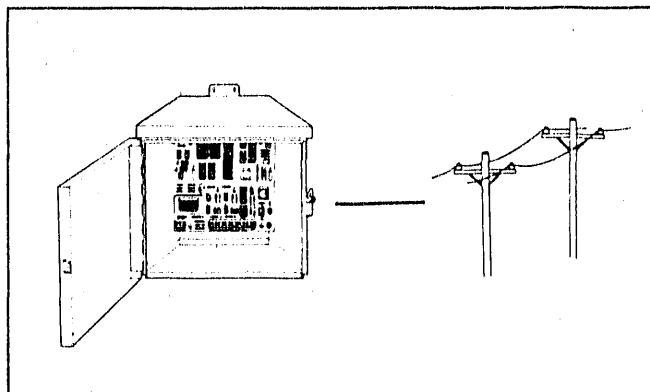

Local Area Network (TeLAN)

TeLAN is the solution to plant applications that demand the flexibility of a modem but find the installation of telephone lines impractical or expensive. With TeLAN, you can communicate from a central computer with up to 16 recorders (64 channels) as far as 2500 feet away. Only common industrial wire and the TeLAN interface are needed for connection. To the computer, communications with recorders on TeLAN is similar to direct communications with recorders with built-in modems.

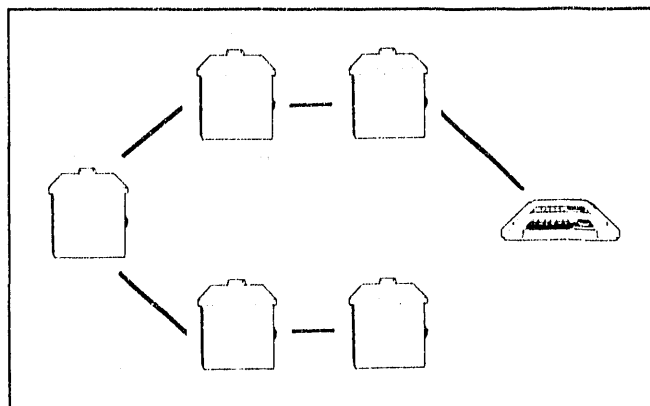

Data Transfer Unit (DTU)

The DTU is a light and compact device that can collect stored historical data directly from recorders in the field. Data collection is simple - connect the DTU to your R-2400 Series Recorder, press the DTU's only button, and any stored data will be copied. A DTU can copy data from up to seven R-2400 Series Recorders at a time. Only a direct command from your computer can clear historical data from the recorders. When you return to your office, the data can be transferred from the DTU to your computer for storage and analyses.

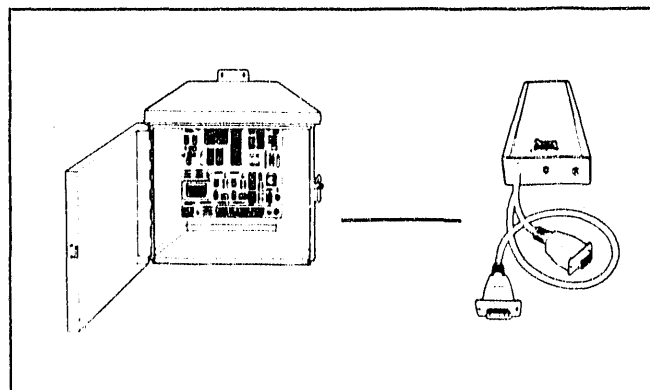

computer ... into your report.

telog®

R-2400 Support Software

The R-2400 Support Software helps you coordinate the activities of your recorders with user-friendly pull-down menus. As you design your data collection schedule for each recorder, you are prompted at every step of the way with your options, and at any point, context-sensitive help screens are available to discuss a particular menu.

Your recorder samples its analog inputs once every second and summarizes the data according to a schedule you have programmed. The recorder can calculate any combination of the minimum, maximum or average of data sampled over a time interval as short as 15 seconds or as long as 12 hours. You can also choose a combination of call-in instructions to be followed by your recorders in the fields. The R-2400 Support Software will tailor the recorder functions according to your application needs.

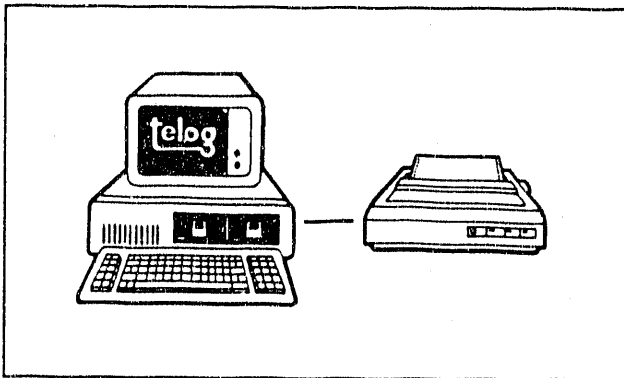

Dedicated, Efficient and Friendly

These are some of the characteristics of the R-2400 Support Software. Once installed and programmed, it performs without assistance. It can answer incoming calls from your field recorders, determine the nature of the calls, record any problems in a message log, collect the data according to schedule, automatically append the collected data to a particular channel's data set and download any new instructions to the recorders before ending each communication session. The autonomous performance of the R-2400 Support Software allows you to concentrate on the design of your test and the analyses of your data.

Data Reduction and Analysis

Once transferred to the computer from the R-2400 Recorder, your data can be examined graphically, numerically, or exported to a spreadsheet program.

Graphic Display

The graphic display function of your data by the R-2400 Support Software is a sophisticated update of a chart recorder function. The graph expansion capability helps you in data analysis and interpretation. You can also have individual values of the graph displayed digitally with their corresponding date and time of occurrence. When you are satisfied with the graphic display you can send it to the printer for a report-ready hard copy.

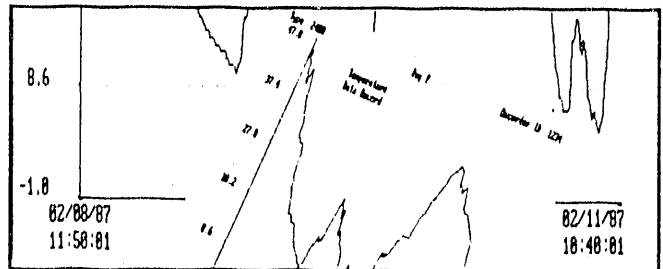

Numerical Display

You can also easily obtain a screen copy or report-ready hard copy of your data. The data are shown alongside their corresponding date and time of occurrence. The numerical data can be compressed or a portion of the data can be selectively printed for your summary report.

```

Output Record for Recorder ID: 2
Description: Telog's 2400 Serj
Address: PO Box 240
          West Henrietta
Communication access method:
Programmed Call-Back Inte:
Programmed Call-Retry Int
Alarm call back interval
Call Status:Recorder in
# of calls: 215
  
```

Export to Spreadsheet

A simple command on the R-2400 Support Software will convert any data set into a file compatible with Lotus 1-2-3 or similar spreadsheet programs. You can elect to export it to the spreadsheet at anytime.

Flexible, powerful, easy-to-use and affordable
The R-2400.

R-2400 Recorder

Summary Specifications



MODELS

R-2401	Single-channel recorder
R-2404	Four-channel recorder

CHANNEL INPUT (factory configured)

Analog Voltage (full scale)	100mv, 200mv, 500mv, 1v, 2v, 5v, 10v, 20v
Current Loop (full scale)	1ma, 5ma, 20ma, 50ma
Event Recording	Records mo/day/yr and hr:min:sec of event for pulse width > 10 msec, 2 sec between pulses
Potentiometric	Resistance range of 10K to 500K ohms
Pressure Strain Gage 4-wire bridge (sensitivity in mv/v)	1, 1.7, 2, 2.5, 3, 4, 5, 6, 7, 7.5, 8, 9, 10, 15, 20
Pulse	Records up to 1000 counts per interval; pulse width > 10 msec, 2 sec between pulses
Temperature	
Ambient (semiconductor sensor)	-40 to 70 C or -40 to 102 C
RTD (100 or 200 ohm platinum)	-200 to 400 C or -200 to 800 C
Thermocouple	Type K -270 to 1372 C Type E -210 to 1000 C Type J -112 to 760 C Type T -23 to 400 C
Wind Direction (scalar averaging)	0 to 360 or 0 to 540 deg 0 to 1 v or 0 to 5v input

RECORDING

Accuracy	+/- 0.2% of full scale
Resolution	0.1% of full scale
Sample Rate	1 sample /sec /channel
Memory	16K bytes for 12,720 data values

PROGRAMMABLE PARAMETERS

Interval Length	15 sec to 12 hr
Stored Data	Any combination of min, max or avg per interval for each channel, 10-digit accumulator for totalization per channel
Calendar Time	mo/day/yr hr:min:sec
Alarm Threshold	High and/or low for each channel

COMMUNICATIONS

Local	RS-232C serial port for local communications with DTU or computer at 300, 1200 or 9600 baud
Telephone	FCC Approved 300-baud Bell 103 auto-dial modem (user selectable auto-answer) supports pulse or tone dialing
TeLAN	Optically isolated (3 wire) network

ENVIRONMENTAL AND MECHANICAL

Enclosure	NEMA 3R rainproof, standard (NEMA 4X waterproof, optional)
Size	8" x 8" x 4" (NEMA 3R)
Weight	8 lb (NEMA 3R)
Operating Conditions	-25 to 60 C, 0 to 100% RH (non-condensing)

POWER

Battery	2 lithium 3.5v cells, 1.8 a-hr
Operating Life	3-4 months at 25 C or above (channel dependent)
External DC	11 to 28 vdc @ 40 ma
External AC	120 vac @ 20 ma

COMPUTER REQUIREMENTS

Computer	IBM/XT/AT/PS2 or compatible with 512K bytes of RAM (hard disk recommended)
Graphics	IBM Color Graphics Adapter, EGA, VGA, or Hercules card
Interface Ports	1 parallel port (for printer) 1 RS-232C serial port
Modem	1 300-baud Hayes compatible modem (internal or external)

Lotus 1-2-3 is the trademark of Lotus Development Corp and IBM PC/XT/AT/PS2 are the trademarks of International Business Machines.

Specifications subject to change without notice.

REPRESENTATIVE:

Telog Instruments, Inc.

P.O. Box 240
West Henrietta, NY 14586

Phone: (716)-359-1110
Fax: (716)-359-9401

THE INFILTEC BLOWER DOOR

Light . . . Easy . . . Accurate.

THE INFILTEC BLOWER DOOR

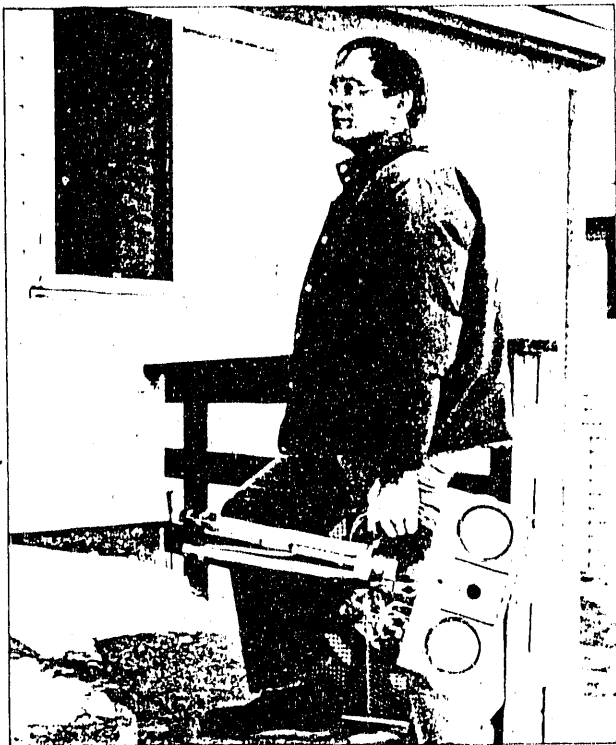

Lightweight and portable, the INFILTEC blower door will fit into any car and can be moved, installed and operated by one person. Setup is simple and takes less than ten minutes. All the operator needs is standard household current and an open door. (There's no need to remove existing doors.)

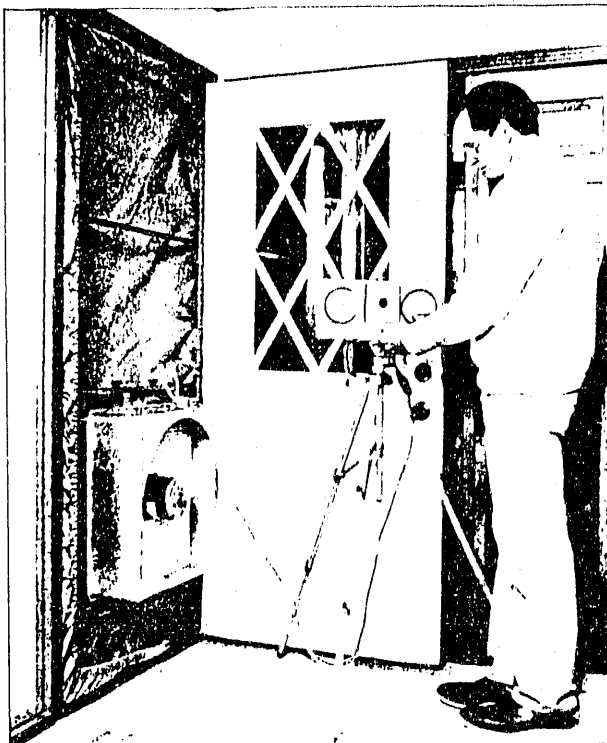

Easy to operate from installation to assessment, INFILTEC saves time and labor. Portable and strong, the INFILTEC door module's rugged steel frame expands to slightly smaller than the door frame. An inflatable tube fitted around the edge of the frame forms the airtight seal. The calibrated fan module simply snaps into place.

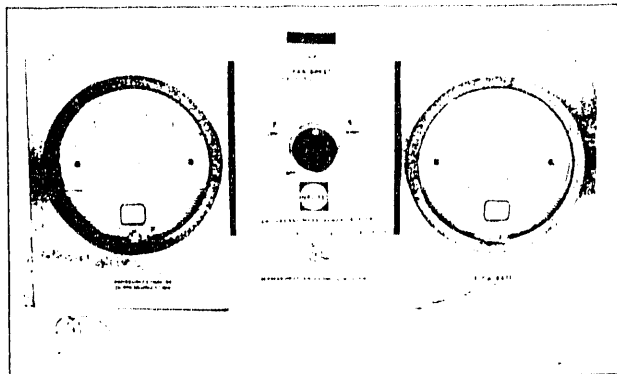

Simple single-gauge readings of air flow and pressure differential provide a quick and precise assessment.

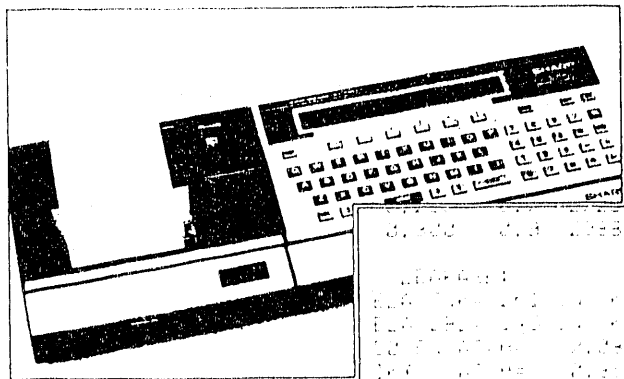

Accurate and detailed data read-out is available with your choice of several optional pocket computers which are programmed to report everything from the effects of temperature, pressure, computation of the leakage area, and air changes-per-hour to exacting amount and time of payback once the determined leakage is stopped.

The INFILTEC Blower Door. Light . . . Easy . . . Accurate.

Meets ASTM Standards. Free Recalibration If Needed. 30 Day Money-back Guarantee. 90 Day Warranty.

Wisconsin Energy Conservation Corporation
1045 East Dayton Street
Madison, Wisconsin 53703
1-608-256-1620

SPECIFICATIONS

CONTROLS

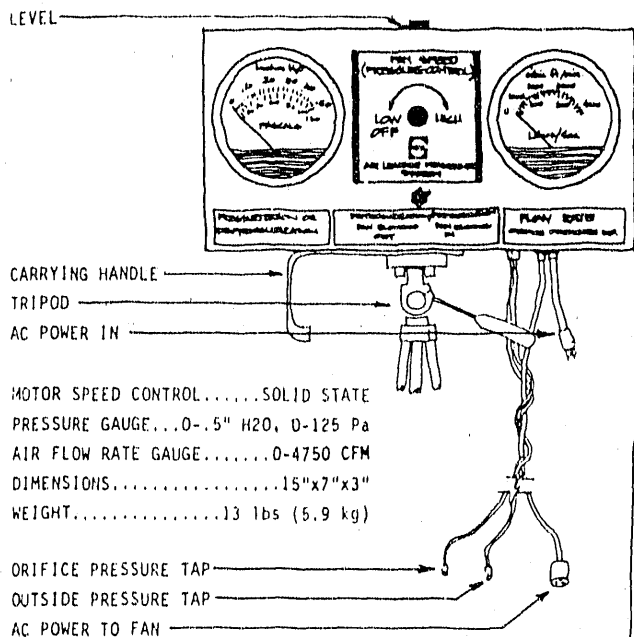

INFILTEC

FAN

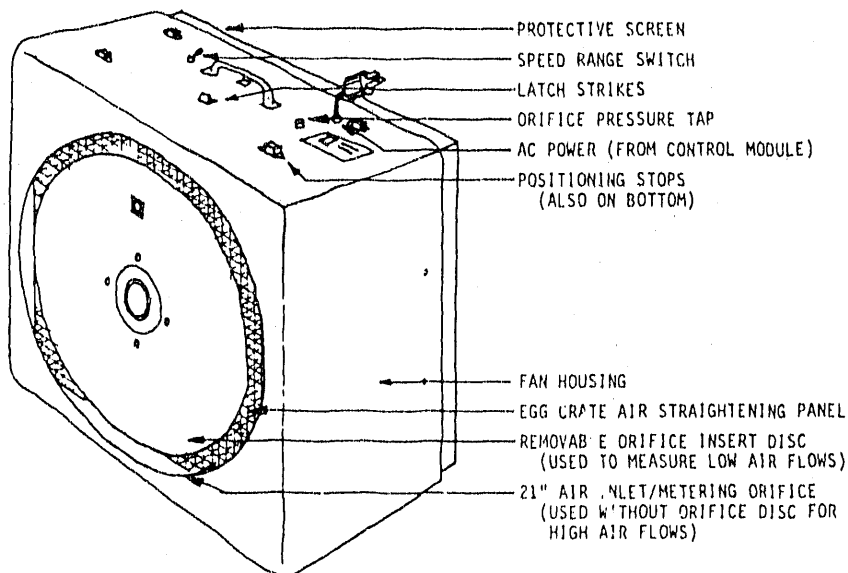

DOOR

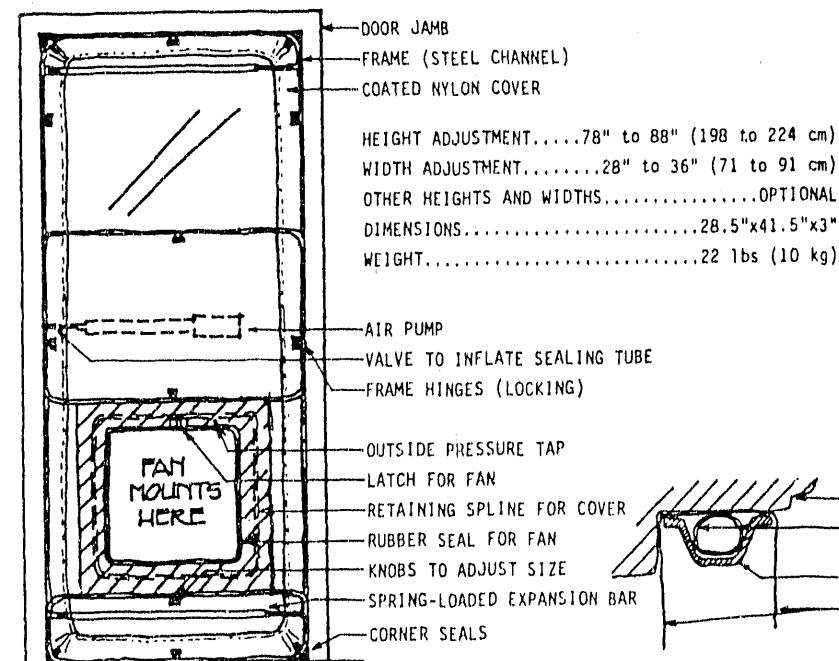

MOTOR.....3/4HP, AC

POWER.....110 VAC, 60 Hz, 10 Amps (optional 220 VAC, 50Hz)

FAN CAPACITY.....4250 CFM at .2" H2O

DIMENSIONS.....24x22.5x10 inches (61x57.2x26.6 cm)

WEIGHT.....39 lbs (17.7 kg)

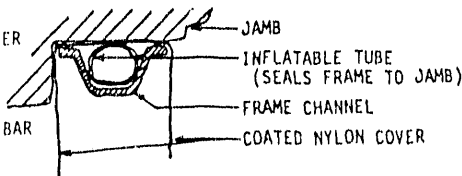

AIR INFILTRATION MEASUREMENT AND CONTROL TECHNOLOGY

□ P.O. Box 1533
Falls Church, Virginia 22041
703-820-7696

□ P.O. Box 1125
Waynesboro, Virginia 22980
703-949-7933



INFILTEC Model R-1 Blower Door

Air leakage reduction has been shown to be the highest priority energy conservation measure for small buildings. The Model R-1 blower door is a professional tool for solving this problem. This powerful calibrated fan is temporarily mounted in the door of a building to measure the building airtightness and to detect the location of leaks. Builders can use the R-1 blower door to certify the airtightness of their energy efficient buildings. Weatherizers can use the R-1 to detect leaks and measure the effectiveness of their airtightness retrofit work. Energy Auditors can use the R-1 to quantify the heat loss due to air infiltration. The INFILTEC blower door has many advanced features:

- * ULTRA LIGHT WEIGHT - One person can move and install the R-1 because it has a lightweight modular design. It can be transported in any car.
- * LOW COST - The advanced design of the R-1 has brought its price down to \$3250, and air leakage computers are available for \$500 or less.
- * SIMPLE TO USE - The R-1 air flow measurement is read directly from a single gauge. No graphs, formulas or computers are necessary.
- * QUICK - The R-1 can be installed in a door in less than 3 minutes.
- * CALIBRATED - The R-1 has the accuracy and precision to meet all present or proposed air leakage measurement standards. Free recalibration is available at our Waynesboro, VA factory.
- * PROFESSIONAL - The R-1 is rugged enough to withstand field use and it has a professional high tech appearance.
- * SAFE TO USE - The R-1 automatically prevents high pressure that could cause building damage.
- * ADVANCED TECHNOLOGY - U.S Patent 4,420,969 and Canadian patent 1,178,826 cover some of the R-1 innovations. Other patents are pending.
- * GUARANTEED - INFILTEC offers a full refund if the purchaser is not satisfied with the R-1 within 30 days of purchase. There is a 90 day warranty against defects.
- * DOCUMENTED - The R-1 includes an operator's manual that describes system operation, measurement procedures, and evaluation of results.

* COMPUTER (OPTIONAL) - INFILTEC offers several portable computers that are programmed to compute leakage areas, air change rates, cost of infiltration, and retrofit payback periods. These computers include cassette interfaces and printers or plotter. Custom software is available.

Your R-1 can usually be shipped within two weeks of your order. Please contact us for current availability information. Unless otherwise specified, shipping is FOB Waynesboro, VA, via UPS. For further information, please contact our Falls Church office.

LYNN

SINCE 1922

MODEL 6500/6500-B

Digital
Combustion
Analyzer

DIGITAL DISPLAY: For Continuous Temperature or Oxygen Readings.

Performs Combustion Efficiency Tests quickly and reliably.

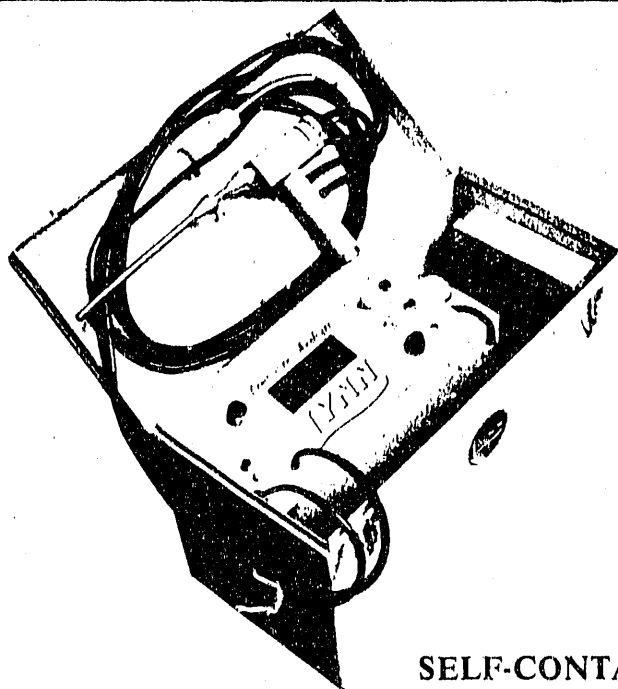

SELF-CONTAINED IN A CARRYING CASE WITH COMPLETE ACCESSORIES.

Simple to operate and rugged, the LYNN Model 6500 and 6500-B are completely portable digital instruments. Available in both Line Voltage and Battery Powered models. The LYNN 6500 and 6500-B are highly accurate instruments allowing technicians to fine tune burners quickly from the very first readings saving countless dollars by avoiding repeat calls.

- Continuous TEMPERATURE or OXYGEN readings while you tune the burner.
- Temperature - displays net stack temperature - Saves time.
- Simplifies smoke, carbon monoxide and draft measurements - Single stack probe for ALL tests.

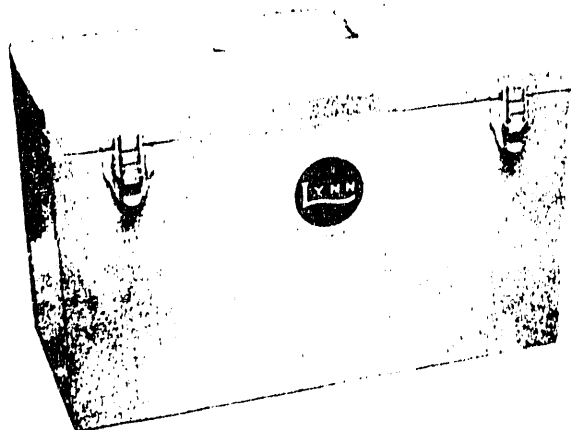

SMALLER and LIGHTER CARRYING CASE

- Fast and easy to operate.
- Slashes per call costs.
- Accurate and reliable sensor
- Solid state circuitry.
- Rugged construction.
- Optional draft gauge.
- Optional C.O. tester

OTHER FEATURES: for Maximum Convenience and Reliability

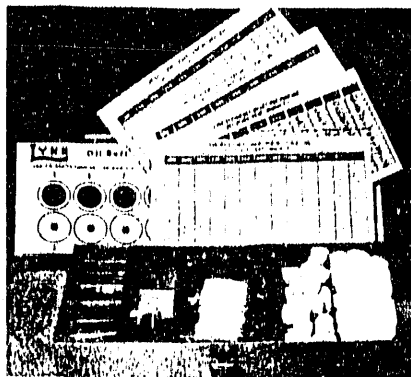

ACCESSORY KIT includes all replacement filters, smoke paper discs, charts, and extra items needed for many months of in-field testing. Included with every Model 6500 and 6500-B Instrument at no extra cost.

The Lynn *Model 6500 & 6500-B* Digital Display Combustion Analyzer is a natural partner for today's more highly specialized energy technician. With more work to do and less time to do it, the continuous temperature or oxygen readings and the instrument's fast overall response make it possible to do a superior job in much less time. Thus your company saves on technician time while the heating system owner saves energy.

This instrument really makes the job easy. First of all, it displays correct net temperature readings during the tests. Then a simple twist of a knob is all you do to calibrate the oxygen system to precise accuracy. Slip the probe in the stack and you're ready to tune the burner.

Remember, not only does the *Model 6500 & 6500-B* track the burner-tuning process with its continuous temperature and oxygen percentage dials, but draft and smoke measurements are also made using the same stack probe! Leave it to Lynn Products Company to think ahead and keep things simple.

So request a demonstration. The first time you see *6500 & 6500-B* digital displays at work, you'll know why you should have one at your side, and on your side.

Call us; we're as near as your phone.

OTHER MODELS AVAILABLE ARE:

MODEL 6100/6100B: Measures oxygen, Stack Temperature and smoke on an analog panel meter.

MODEL 6400: Measures oxygen, Net stack temperature, smoke and computes combustion efficiency for five (5) fuels. (#2, 4, 6 oil, natural gas & propane on a digital panel meter.

SPECIFICATIONS:

POWER:

6500: 110v; 60 cycles, 3Amp fuse, 6ft. of power cord.

6500B: Rechargeable nickel cadmium batteries.

DIMENSIONS:

Instrument:

Self-contained instrument in carrying case: 18" wide x 8" deep x 12" high.

OPTIONS:

Lynn Carbon Monoxide Tester: (pictured)

A must for testing gas fired equipment. This Lynn tester is an excellent indicator of incomplete combustion. Carbon Monoxide (CO) should never exceed 400 ppm (parts per million) and this tool will fulfill your needs.

Lynn Draft Tester:

Draft measurements are an essential part of combustion testing as draft determines the rate at which combustion gases pass through the furnace or boiler. The Lynn Draft Tester is a simple, accurate, low-cost tool used to perform these measurements.

OPERATING RANGES:

OXYGEN: 0.0% to 25% with 1/10 percent intervals.

TEMPERATURE: Net stack (and ambient) temperature range: 100° to 999° with 1° intervals.

Contact us for more information:

Printed in U.S.A.

LYNN

PRODUCTS COMPANY

400 BOSTON STREET — LYNN MASSACHUSETTS 01905

Phone: 617-593-2500

APPENDIX D. HOUSE CHARACTERISTICS SURVEY

Information on the physical characteristics of the house and its mechanical systems (space-heating, space-cooling, and water-heating) will be collected using this survey instrument developed for the study.

Version: April 12, 1991

Auditor: _____
Date: _____**FUEL OIL STUDY HOUSE CHARACTERISTICS SURVEY****IDENTIFICATION**

House ID: _____ Subgrantee name: _____

Occupant name: _____ Phone number: _____

Occupant address: _____

GENERALType: _____ SFD - single-family detached MFS - small (2-4 units) multifamily MH - manufactured or
SFA - single-family attached MFL - large (>4 units) multifamily mobile home

A single-family housing unit is a structure that provides living space for one household or family. The structure may be detached, attached on one side, or attached on two sides. Attached houses are considered single-family houses as long as the house itself is not divided into more than one housing unit and has an independent outside entrance. A single-family house is contained within walls that go from the basement (or ground floor, if there is no basement) to the roof. A mobile home with one or more rooms added is a single-family home. Row houses and side-by-side duplexes (twins) are typically single-family houses.

A small multifamily house or building is a structure that is divided into living quarters for two, three, or four families or households. This category also includes houses originally intended for occupancy by one family (or for some other use) that have since been converted to separate dwellings for two to four families. Typical arrangements in these types of living quarters are separate apartments downstairs and upstairs, or one apartment on each of three or four floors. Over-and-under duplexes are typically in this category.

A mobile or manufactured home is a structure that has all the facilities of a dwelling unit but is built on a movable chassis. It may be placed on a permanent or temporary foundation and may contain one room or more. If rooms are added to the structure, it is considered a single-family home.

Are the following systems shared with other housing units: space-heating system _____ (Y,N)
space-cooling system _____ (Y,N)
water-heating system _____ (Y,N)

If SFA, number of attached housing units: _____ (NA, 1, 2, ...) (typically 2 or less)

EXTERNAL DOORS

Door type	Number without storm door	Number with storm door
Hollow core wood door		
Solid core wood door		
Insulated metal door		

House ID: _____

WINDOWS

Window glazing type	Frame type	Storm window	Area (ft ²)

Window glazing type	
SP	single pane
DP	double pane
TP	triple pane
GB	glass block
TE	temporary (cardboard, plastic, etc.)

Frame type	
W	wood
M	metal
V	vinyl
X	other
N	none

Storm window	
W	wood
M	metal
X	other
N	none

FLOOR AREAS AND VOLUMES

Floor	Total area (ft ²)	Intentionally heated area (ft ²)	Intentionally air-conditioned area (ft ²)	Volume (ft ³)
Basement				
First floor				
Second floor				
All other floors				
Total				

An intentionally heated (air conditioned) space is one with equipment and/or distribution outlets designed to maintain a desired temperature in the space. An unintentionally heated (air conditioned) space is one that is heated (cooled) primarily from equipment jacket and/or distribution losses (there is little control over the resulting temperature). A space is not heated (air conditioned) if there is no source of heating (cooling) to alter the natural temperature of the space. For example, a basement heated primarily from equipment jacket and/or distribution system losses is not considered to be an intentionally heated space. A window air conditioner cools only the room the unit is installed in, not adjacent rooms. If a space was designed to be intentionally heated (cooled) but is maintained by the occupant in an unheated (uncooled) condition (by closing registers and doors, for example), the space should still be considered a heated (cooled) space with one exception: an unfinished basement or other unfinished room with a distribution system that is always shut off should be considered unintentionally heated (cooled).

Floor heights used to calculate volume are floor to floor except for the top floor, which is floor to ceiling.

Number of intentionally heated stories: _____ (1, 1.5, 2, 2.5, 3, 3.5, 4 or more)

House ID: _____

ATTICS

FINISHED ATTIC AREAS			
	Area (ft ²)	Existing insulation	
		Type	Depth (inches)
Collar beam			
Kneewall			
Roof rafter			

UNFINISHED ATTIC AREAS			
Attic type	Floor area (ft ²)	Existing insulation	
		Type	Depth (inches)

Finished attic areas are defined in the figures on the following page.

Areas pertain to attic areas adjacent to intentionally heated or air-conditioned spaces. For example, the area above an unconditioned garage should not be included.

Existing insulation type	
BC	blown cellulose
BF	blown fiberglass
FB	fiberglass batt
RB	rigid board or foam
BRW	blown rock wool
RWB	rock wool batt
V	vermiculite
X	other
N	none

Attic type	
F	floored
U	unfloored
C	cathedral
L	flat roof

Are attic vents present: _____ (Y,N)

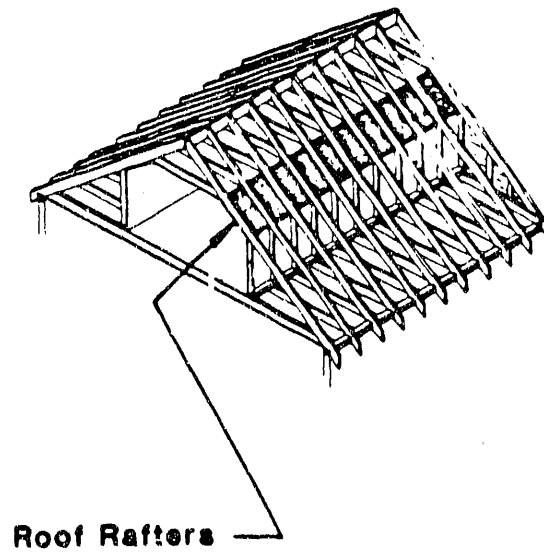
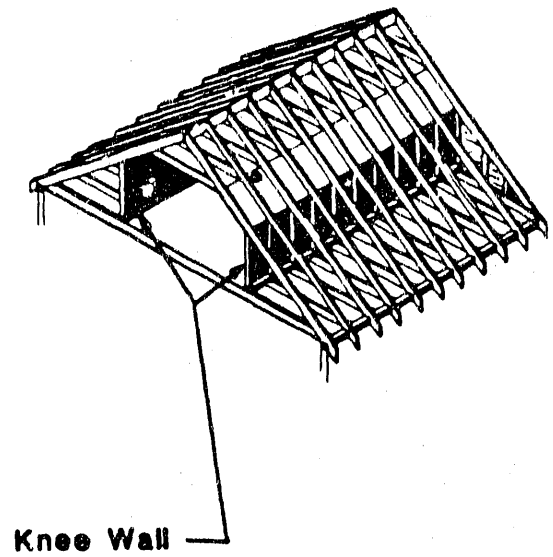
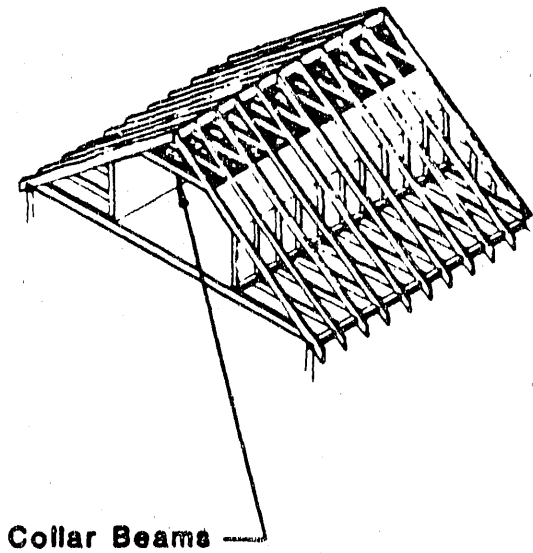

EXTERIOR WALLS

Wall exposure	Exterior type	Wall type	Gross wall area (ft ²)	Insulated sheathing (Y/N)	Existing insulation	
					Type	Depth (inches)

Shared walls found in duplexes and row houses are not exterior walls.

The type of load bearing structure is the wall type. The type of facing on the wall is the exterior type.

Wall exposure	
O	outside
N	non-conditioned attic space
B	buffered space (garage, etc.)

Exterior type	
WO	wood or masonite
AL	aluminum, steel or vinyl
ST	stucco
BR	brick or stone
AS	asphalt shingle
WS	wood shingle
RA	rolled asphalt
N	other
N	none

Wall type	
PF	platform frame
BF	balloon frame
BL	block
ST	stone or masonry
X	other

Insulation type	
BC	blown cellulose
BF	blown fiberglass
FB	fiberglass batt
RB	rigid board or foam
BRW	blown rock wool
RWB	rock wool batt
X	other
N	none

FOUNDATION SPACES

Type	Space status	Basement or crawl space ceiling area (ft ²)	Basement or crawl space ceiling insulation thickness (inches)	Perimeter (band joist)		Wall height		Existing wall insulation	
				Length (ft)	Percent exposed	Total (ft)	Percent above ground	Type	Thickness (inches)

Ceiling area - For slab-on-grade, the area of the intentionally conditioned slab floor.

Perimeter length - Do not include perimeter bordering another foundation space.

Percent exposed - For basements and crawlspaces, the percent of band joist length that is exposed to the outside and not insulated.

Total wall height - Height of basement or crawlspace wall; an estimated average if the height is not uniform.

Foundation type	
B	basement
C	crawlspace
US	uninsulated slab
IS	insulated slab

Foundation space status	
NH	not heated
IH	intentionally heated
UH	unintentionally heated

Existing wall insulation type	
BC	blown cellulose
BF	blown fiberglass
FB	fiberglass batt
RB	rigid board or foam
BRW	blown rock wool
RWB	rock wool batt
X	other
N	none

DOMESTIC WATER-HEATING SYSTEM

Fuel: _____ (NG-natural gas, P-propane, O-oil, K-kerosene, E-electricity, W-wood, S-solar, X-other, N-None)

Type: _____ (SA-stand alone system, T-tankless [integrated with space-heating system], X-other, N-None)

Is an external blanket insulation used? _____ (Y,N,NA)

Location: _____ (NH - non-heated space, IH - intentionally heated space, UH - unintentionally heated space)

House ID: _____

APPLIANCES

Appliance	Fuel	Quantity	Location
Cooking range			
Stove top			
Detached oven			
Microwave oven	E		
Refrigerator	E		
Dishwasher	E		
Deep freezer	E		
Clothes washer	E		
Clothes dryer			
Whole house fan	E		
Attic ventilation fan	E		
Well pump	E		
Water bed heater	E		
Other: _____			

Fuel	
NG	natural gas
P	propane
O	oil
K	kerosene
E	electricity
W	wood
C	coal
X	other

Location	
NH	non-heated space
IH	intentionally heated space
UH	unintentionally heated space

AIR CONDITIONERS

Unit type	Nameplate information						Age (years)
	Input (watts)	Voltage (volts)	Current (amps)	Efficiency		Output (Btu/h)	
				EER	SEER		

Unit type	
CAC	central air conditioner
CHP	central heat pump
WAC	window air conditioner
WHP	window heat pump
EC	evaporative cooler
X	other

House ID: _____

SPACE-HEATING SYSTEMS

PRIMARY OIL-FIRED SYSTEM	
System type (see next page)	
System age	years
Original fuel if converted system (see next page or NA)	
Location (see next page)	
Actual installed nozzle size (value and units)	
Vent damper present (Y,N)	
Flame retention head burner present (Y,N)	
Smart thermostat present (Y,N)	
For boilers, outdoor temperature reset present (Y,N,NA)	

AUXILIARY SYSTEMS	
Type (see next page)	Fuel

The primary oil-fired system is the system metered under the study.

DISTRIBUTION SYSTEM

Location	Is any part of the distribution system present in this location? (Y,N,NA)	If present, is the distribution system insulated? (Y,N)	If present, is the structural integrity sound?
Intentionally heated area			
Unintentionally heated area			
Un-heated area			

Does the distribution system include a return system? _____ (Y,N,NA)

Fuel	
NG	natural gas
P	propane
O	oil
K	kerosene
E	electricity
W	wood
C	coal
X	other

Location	
NH	non-heated space
IH	intentionally heated space
UH	unintentionally heated space

SPACE-HEATING SYSTEM TYPES			
Central systems		In-space heaters	
1	forced air furnace	Fossil fueled:	
2	gravity furnace	7	room heater
3	steam boiler	8	forced air wall furnace
4	hot water boiler with radiators/convectors	9	gravity wall furnace
5	hot water boiler for slab heating	10	forced air floor furnace
6	heat pump	11	gravity floor furnace
Other		12	vaporizing pot heater (oil and kerosene)
21	wood or coal stove	13	portable kerosene
22	fireplace	Electric:	
23	stove top or oven	14	wall
24	other	15	floor
		16	baseboard
		17	ceiling radiant (imbedded cable)
		18	wall or floor radiant (imbedded cable)
		19	portable (cord-connected)
		20	window heat pump

APPENDIX E. PRE-WEATHERIZATION DATA COLLECTION FORM

Information on the floor area, volume, number of rooms, and number of heated rooms will be collected at the beginning of the pre-weatherization period using this form.

Version: February 6, 1991

Auditor: _____
Date: _____**FUEL-OIL STUDY PRE-WEATHERIZATION DATA COLLECTION FORM****IDENTIFICATION**

House I.D.: _____ Subgrantee name: _____

Occupant name: _____ Phone number: _____

Occupant Address: _____

SPACE-HEATING SYSTEM NOZZLE SIZE: _____ (value and units, likely GPH)

HOUSE FLOOR AREA

excluding basement: _____ square feet

basement only: _____ square feet

HOUSE VOLUME

excluding basement: _____ cubic feet

basement only: _____ cubic feet

ROOMS

How many of each of the following rooms does this house have?

	<u>Number</u>
Bedrooms ¹	_____
Full bathrooms ²	_____
Half bathrooms ³	_____
All other rooms ⁴	_____

How many rooms are currently being heated? _____

¹For one-bedroom efficiency or studio apartment, record "0 bedrooms" and correct number of bathrooms.²Full bathroom is defined as having a sink with running water and flush toilet and bathtub or shower.³Half bathroom is defined as having a toilet or bathtub or shower.⁴Do not count laundry rooms, foyers, or unfinished storage space. Only count porches if they are enclosed and used year-round.

APPENDIX F. OCCUPANT QUESTIONNAIRES

Information will be collected from the occupants of the houses using these questionnaires. Separate questionnaires were developed for the weatherized and control houses because of slight wording differences that were required.

version 18W
5/10/91

Interviewer _____

Date of Interview _____

Time Started _____

FUEL-OIL STUDY OCCUPANT QUESTIONNAIRE
WEATHERIZED HOME

A. Identification

INTERVIEWER INSTRUCTIONS:

Complete Questions A1, A2, and A4 using data from the information sheet before starting the interview.

A1. Household Identifier _____

A2. Name of WAP Applicant _____

SCREENER:

ASK TO SPEAK TO THE APPLICANT NAMED IN QUESTION A2. IF AVAILABLE, READ THE FOLLOWING AND GO TO QUESTION A3.

Your home was weatherized as a participant in the Weatherization Assistance Program. As a follow up to that we would like to conduct an interview to learn more about how that weatherization may have affected your energy use and ask your opinions regarding the value of weatherization.

IF THE APPLICANT NAMED IN QUESTION A2 IS NOT AVAILABLE, READ THE FOLLOWING AND THEN ASK QUESTION 1:

Your home was weatherized as a participant in the Weatherization Assistance Program. As a follow up to that we would like to conduct an interview to learn more about how that weatherization may have affected your energy use and ask your opinions regarding the value of weatherization.

1. I'd like to speak to a person over eighteen years of age who is knowledgeable about paying the energy bills. Is that person available? (IN ORDER TO QUALIFY, THE RESPONDENT DOES NOT HAVE TO PAY THE CHECK. AS LONG AS THE RESPONDENT IS KNOWLEDGEABLE ABOUT THE ENERGY USE AND/OR BILLS, HE OR SHE QUALIFIES.)

1. YES, THE PERSON YOU ARE SPEAKING TO IS THE RESPONDENT. CONTINUE WITH QUESTION A3.

2. YES, RESPONDENT IS ANOTHER PERSON. . . ONCE A RESPONDENT IS PRESENT, RETURN TO THE INTRODUCTION AND CONFIRM THAT THE RESPONDENT IS OVER 18 AND IS KNOWLEDGEABLE ABOUT PAYING THE ENERGY BILLS. IF THE RESPONDENT QUALIFIES, CONTINUE WITH QUESTION A3.

3. NO, RESPONDENT IS NOT AVAILABLE. (NAMES: _____) IDENTIFY NAMES OF SEVERAL PEOPLE WHO MIGHT BE SUITABLE RESPONDENTS. INFORM THE CURRENT RESPONDENT THAT WE WILL CONDUCT THE INTERVIEW OVER THE TELEPHONE AT A LATER DATE. LEAVE A COPY OF THE EXHIBITS AT THE HOUSE. DO NOT PROCEED WITH THE INTERVIEW.

INTERVIEWER INSTRUCTIONS:
IF RESPONDENT NEEDS INFO: The survey is a part of the Weatherization Assistance Program. The survey is required of every participant in the Fuel Oil Study.
IF RESPONDENT IS HESITANT: Your answers to these questions will provide valuable information to the Department of Energy. The interview will take approximately 30 minutes.

A3. Name of respondent _____
Relation to WAP applicant _____
 RESPONDENT IS SAME AS WAP APPLICANT

A4. Dates of WAP weatherization work _____

- A5. I want to confirm that the weatherization work done by the Weatherization Assistance Program took place on (READ DATES FROM QUESTION A4). (RECORD DATES BELOW IF RESPONDENT GIVES DIFFERENT DATES.)

DATES _____

- RESPONDENT CONFIRMS THAT WEATHERIZATION TOOK PLACE ON THE SAME DATES AS QUESTION A4.
- DON'T REMEMBER

INTERVIEWER INSTRUCTIONS:

If respondent has trouble remembering the dates in Questions A6, A7, and A8, probe for:

- Season
- Major life event
- Major news story or political event happening at that time

Then, ask for year (and month) again.

- A6. In what year was this home built? Just your estimate.*

- | | | |
|--------------------------------------|------------------------------------|-------------------------------|
| <input type="checkbox"/> Before 1900 | <input type="checkbox"/> 1940-1949 | <input type="checkbox"/> 1985 |
| <input type="checkbox"/> 1900-1909 | <input type="checkbox"/> 1950-1959 | <input type="checkbox"/> 1986 |
| <input type="checkbox"/> 1910-1919 | <input type="checkbox"/> 1960-1969 | <input type="checkbox"/> 1987 |
| <input type="checkbox"/> 1920-1929 | <input type="checkbox"/> 1970-1979 | <input type="checkbox"/> 1988 |
| <input type="checkbox"/> 1930-1939 | <input type="checkbox"/> 1980-1984 | <input type="checkbox"/> 1989 |
| | | <input type="checkbox"/> 1990 |

- A7. In what year did your family move into this home?*

- | | | |
|--------------------------------------|------------------------------------|-------------------------------|
| <input type="checkbox"/> Before 1900 | <input type="checkbox"/> 1940-1949 | <input type="checkbox"/> 1985 |
| <input type="checkbox"/> 1900-1909 | <input type="checkbox"/> 1950-1959 | <input type="checkbox"/> 1986 |
| <input type="checkbox"/> 1910-1919 | <input type="checkbox"/> 1960-1969 | <input type="checkbox"/> 1987 |
| <input type="checkbox"/> 1920-1929 | <input type="checkbox"/> 1970-1979 | <input type="checkbox"/> 1988 |
| <input type="checkbox"/> 1930-1939 | <input type="checkbox"/> 1980-1984 | <input type="checkbox"/> 1989 |
| | | <input type="checkbox"/> 1990 |

IF "1989" OR LATER ON QUESTION A7, ASK:

- A8. In which month did you move in?*

- | | | |
|-----------------------------------|---------------------------------|------------------------------------|
| <input type="checkbox"/> January | <input type="checkbox"/> May | <input type="checkbox"/> September |
| <input type="checkbox"/> February | <input type="checkbox"/> June | <input type="checkbox"/> October |
| <input type="checkbox"/> March | <input type="checkbox"/> July | <input type="checkbox"/> November |
| <input type="checkbox"/> April | <input type="checkbox"/> August | <input type="checkbox"/> December |

B. Major Heating Fuel

Next, I will ask some questions about the fuels you used to heat your home last winter before and after weatherization on (READ DATES FROM QUESTION A4). Throughout the survey, when I ask about last winter before weatherization, I mean October, November, and December of 1990. When I ask about last winter after weatherization, I mean February, March, and April of 1991.

INTERVIEWER INSTRUCTIONS:
 If two or more heating fuels are used, the **main heating fuel** is the one that provides most of the heat for the home. The main heating fuel may not necessarily be the one used for the central heating system.

(HAND RESPONDENT EXHIBIT BOOKLET)

B1. Please look at Exhibit B1. What was the **one main heating fuel** used for heating your home last winter **before** weatherization?*

	B1 Main Fuel (Mark only one)	B2 (Mark all other fuels that apply)
Gas from underground pipes serving the neighborhood.	[]	[]
Bottled gas (LPG or Propane).	[]	[]
Fuel oil.	[]	[]
Kerosene or coal oil.	[]	[]
Electricity.	[]	[]
Coal or coke.	[]	[]
Wood.	[]	[]
Solar collectors.	[]	[]
Other (specify) _____	[]	[]
NO FUELS USED.	[]	[]
DON'T KNOW.	[]	[]

B2. Please look at Exhibit B1 again. You mentioned that your **main heating fuel** used last winter **before** weatherization was (FUEL FROM QUESTION B1). What **other** fuels were used to heat your home last winter before weatherization -- including those used to provide heat just occasionally? Don't forget to include fuels that ran portable heaters if you used them. (MARK ALL THAT APPLY IN COLUMN B2. IF NONE, MARK "NO FUELS USED")*

IF ADDITIONAL FUELS ARE IDENTIFIED FROM QUESTION B2, ASK:

B3. Going back to your **main heating fuel** used last winter **before** weatherization-- (FUEL FROM QUESTION B1) -- did this fuel provide all or almost all of the heat for your home, about three-fourths, or closer to half of the heat for your home?*

All or almost all (95% or more)
 About three-fourths (67-94%)
 Closer to half (66% or less)
 DON'T KNOW/REMEMBER

Now, I will ask similar questions about the fuels you used last winter after weatherization.

B4. Please look at Exhibit B1 again. What was the **one main heating fuel** used for heating your home last winter **after** weatherization?*

	B4 Main Fuel (Mark only one)	B5 (Mark all other fuels that apply)
Gas from underground pipes serving the neighborhood.	[]	[]
Bottled gas (LPG or Propane).	[]	[]
Fuel oil.	[]	[]
Kerosene or coal oil.	[]	[]
Electricity.	[]	[]
Coal or coke.	[]	[]
Wood.	[]	[]
Solar collectors.	[]	[]
Other (specify) _____	[]	[]
NO FUELS USED.	[]	[]
DON'T KNOW.	[]	[]

B5. Please look at Exhibit B1 again. You mentioned that your **main heating fuel** used last winter **after** weatherization, was (FUEL FROM QUESTION B4). What **other** fuels were used to heat your home last winter after weatherization -- including those used to provide heat just occasionally? Don't forget to include fuels that ran portable heaters if you used them. (MARK ALL THAT APPLY IN COLUMN B5. IF NONE, MARK "NO FUELS USED")*

IF ADDITIONAL FUELS ARE IDENTIFIED FROM QUESTION B5, ASK:

B6. Going back to your **main heating fuel** used last winter **after** weatherization -- (FUEL FROM QUESTION B4) -- did this fuel provide all or almost all of the heat for your home, about three-fourths, or closer to half of the heat for your home?*

- [] All or almost all (95% or more)
- [] About three-fourths (67-94%)
- [] Closer to half (66% or less)
- [] DON'T KNOW/REMEMBER

B7a. Please look at Exhibit B7. Last winter **before** the weatherization work was done, did you use any of the following to **help** heat your home? (CHECK AS MANY AS WERE USED.)

(B7a) <u>BEFORE</u>	(B7b) <u>AFTER</u>
<input type="checkbox"/> Wood/coal stove.	<input type="checkbox"/>
<input type="checkbox"/> Fireplace.	<input type="checkbox"/>
<input type="checkbox"/> Cooking stove/range/oven.	<input type="checkbox"/>
<input type="checkbox"/> Non-portable room heater burning gas, oil, or kerosene.	<input type="checkbox"/>
<input type="checkbox"/> Portable kerosene heater.	<input type="checkbox"/>
<input type="checkbox"/> Non-portable electric heater	<input type="checkbox"/>
<input type="checkbox"/> Electric portable heater (cord-connected).	<input type="checkbox"/>
<input type="checkbox"/> Other (specify): _____	<input type="checkbox"/>
<input type="checkbox"/> NONE.	<input type="checkbox"/>

B7b. Please look at Exhibit B7 again. Last winter **after** the weatherization work was done, did you use any of the following to **help** heat your home? (CHECK AS MANY AS WERE USED IN COLUMN B7b.)

INTERVIEWER INSTRUCTIONS:

Confirm that responses to B7a do not contradict responses to B1 and B2. Confirm that responses to B7b do not contradict responses to B4 and B5. Probe the respondent if the responses contradict.

ASK QUESTION B8 ONLY FOR EACH ITEM IN QUESTION B7 USED BOTH BEFORE AND AFTER WEATHERIZATION:

B8. Please turn to Exhibit B8. Please tell me how often you used the following to help heat your home last winter **after** the weatherization work was done, as compared to last winter before the weatherization work was done. Did you use it less, about the same, or more after weatherization as compared to before weatherization? (CIRCLE ONE NUMBER IN EACH LINE ASKED.)

	Used Less <u>After</u>	Used About <u>The Same</u>	Used More <u>After</u>
1. Wood/coal stove	1	2	3
2. Fireplace	1	2	3
3. Cooking stove/range/oven	1	2	3
4. Non-portable room heater burning gas, oil, or kerosene	1	2	3
5. Portable kerosene heater	1	2	3
6. Non-portable electric heater	1	2	3
7. Electric portable heater (cord-connected)	1	2	3
8. Other (_____)	1	2	3

C. Demographics

Now I have some questions about the people who live here and about your housing costs.

- C1. Please tell me how many people living in your home last winter **before** weatherization were . . . (READ EACH ITEM).

Under the age of 5 _____

Between 5 and 17 years old _____

Between 18 and 64 years old _____

65 years old or older _____

TALLY -- so that is (READ NUMBER) in total?

 ENTER CORRECT TOTAL HERE

- C2. You have told me that there were (READ TOTAL NUMBER FROM QUESTION C1) people living in your home last winter **before** weatherization. How many people were living in your home last winter **after** weatherization?

 NUMBER OF RESIDENTS

[] SAME NUMBER AFTER WEATHERIZATION AS BEFORE
 WEATHERIZATION

- C3. Were any of the people living in your home last winter **before** weatherization handicapped? By handicapped, I mean a permanent condition. I do not mean a temporary condition, such as a short-term illness. (EYEGLASSES ARE NOT CONSIDERED A HANDICAP). (IF YES, ASK HOW MANY.)

 NUMBER HANDICAPPED

C4. Do you or members of your household own your home, or rent?*

- Own (buying)
- Rent
- Occupied without payment of rent (SKIP TO SECTION D)

FROM QUESTION C4, IF HOUSEHOLD OWNS OR PAYS RENT, ASK:

C5. Please tell me which category best describes the monthly rent or mortgage payment the household pays for your home. Is it . . .? Stop me when I reach the category. (READ CATEGORIES.)

- less than \$200 per month
- \$201 - 300 per month
- \$301 - 400 per month
- \$401 - 500 per month
- \$501 - 600 per month
- \$601 - 700 per month
- \$701 - 800 per month
- \$801 - 900 per month
- more than \$900 per month
- OWNED, MORTGAGE PAID OFF (SKIP TO SECTION D)
- DON'T KNOW

C6. Does this payment include: (READ ITEMS AND PROBE FOR "YES" OR "NO".)

	Yes	No	DON'T KNOW
1. fuel oil.	<input type="checkbox"/>	<input type="checkbox"/>	<input type="checkbox"/>
2. electricity.	<input type="checkbox"/>	<input type="checkbox"/>	<input type="checkbox"/>
3. natural gas.	<input type="checkbox"/>	<input type="checkbox"/>	<input type="checkbox"/>
4. property tax.	<input type="checkbox"/>	<input type="checkbox"/>	<input type="checkbox"/>
5. insurance (house or renter's).	<input type="checkbox"/>	<input type="checkbox"/>	<input type="checkbox"/>
6. water.	<input type="checkbox"/>	<input type="checkbox"/>	<input type="checkbox"/>
7. garbage.	<input type="checkbox"/>	<input type="checkbox"/>	<input type="checkbox"/>
8. other (specify): _____.	<input type="checkbox"/>	<input type="checkbox"/>	<input type="checkbox"/>

D. Conditioned Living Space

My next question is about the number of different types of rooms in your home. Remember that when I ask about last winter before weatherization, I mean October, November, and December of 1990. When I ask about last winter after weatherization, I mean February, March, and April of 1991. Weatherization work was done to your home on (READ DATES FROM QUESTION A4).

INTERVIEWER INSTRUCTIONS:

For one-bedroom efficiency or studio apartment, record "0 bedrooms" and number of bathrooms and other rooms.

Full Bathroom -- sink with running water and flush toilet and bathtub or shower.

Half Bathroom -- toilet or bathtub or shower

D1. How many of each of the following rooms does this home have? (ASK EACH ITEM AND RECORD NUMBER FOR EACH.)*

	<u>D1</u> Total Number	<u>D2A</u> Number heated last winter before weatherization	<u>D2B</u> Number heated last winter after weatherization
Bedrooms?	_____	_____	_____
Full bathrooms?	_____	_____	_____
Half bathrooms?	_____	_____	_____
All other rooms: (Do not count laundry rooms, foyers or unfinished storage space. Only count porches if they are enclosed and used year-round.)	_____	_____	_____

D2. (FOR EACH TYPE OF ROOM THE RESPONDENT HAS IN THE HOME, ASK D2A, THEN D2B. A HEATED ROOM IS ONE THAT IS WARM ENOUGH TO BE USED.)

D2a. Of the (READ NUMBER OF ROOMS AND TYPE OF ROOM), how many were heated last winter **before** weatherization (RECORD ABOVE ON COLUMN D2A.)

D2b. And how many (READ TYPE OF ROOM) were heated last winter **after** weatherization? (RECORD ABOVE ON COLUMN D2B.)

E. Thermostat Management

I would now like to ask you some questions about the temperature at which you kept your home.

INTERVIEWER INSTRUCTIONS:

Remember, we are interested in the respondent's perceptions. Ask the respondent for their opinion; avoid checking the thermostat for the actual settings.

If respondent keeps different sections of the home at different temperatures, we want to know the temperature in the part of the house where the people are. If, for example, the heat is turned off upstairs during the day because the family is downstairs, we want the downstairs temperature.

We would like to know the actual temperature of the home. If the respondent doesn't know the temperature, but does know the thermostat setting, record the thermostat setting. Otherwise, probe for best estimate.

E1a. Last winter **before** weatherization, did you keep your home at the same temperature at all times of the day, or did you change the temperature?

- Kept home at same temperature (ASK QUESTION E1B)
 Changed the temperature (GO TO QUESTION E1C)

IF KEPT HOME AT SAME TEMPERATURE ON QUESTION E1A, ASK:

E1b. **Before** weatherization, at what temperature did you **usually** keep your home?

Degrees Fahrenheit: _____
 HEAT TURNED OFF

(GO TO QUESTION E2A)

IF CHANGED THE TEMPERATURE ON QUESTION E1A, ASK:

E1c. **Before** weatherization, at what temperature did you **usually** keep your home during the day **when someone was at home**?*

Degrees Fahrenheit: _____
 HEAT TURNED OFF

E1d. **Before** weatherization, at what temperature did you **usually** keep your home during the day **when no one was at home**?*

Degrees Fahrenheit: _____
 HEAT TURNED OFF

E1e. **Before** weatherization, at what temperature did you **usually** keep your home **during sleeping hours**?*

Degrees Fahrenheit: _____
 HEAT TURNED OFF

(ASK EVERYONE:)

E2a. Last winter **after** weatherization, did you keep your home at the same temperature at all times of the day, or did you change the temperature?

- Kept home at same temperature (ASK QUESTION E2B)
 Changed the temperature (GO TO QUESTION E2C)

IF KEPT HOME AT SAME TEMPERATURE ON QUESTION E2A, ASK:

E2b. **After** weatherization, at what temperature did you **usually** keep your home?

Degrees Fahrenheit: _____
 HEAT TURNED OFF

(GO TO SECTION F)

IF CHANGED THE TEMPERATURE ON QUESTION E2A, ASK:

E2c. **After** weatherization, at what temperature did you **usually** keep your home during the day **when someone was at home?***

Degrees Fahrenheit: _____
 HEAT TURNED OFF

E2d. **After** weatherization, at what temperature did you **usually** keep your home during the day **when no one was at home?***

Degrees Fahrenheit: _____
 HEAT TURNED OFF

E2e. **After** weatherization, at what temperature did you **usually** keep your home **during sleeping hours?***

Degrees Fahrenheit: _____
 HEAT TURNED OFF

F. Events Affecting Energy Use

The next questions are about events which may have affected your energy use last winter. (REMIND RESPONDENT IF NECESSARY): Remember that when I ask about last winter before weatherization, I mean October, November, and December of 1990. When I ask about last winter after weatherization, I mean February, March, and April of 1991. Weatherization work was done to your home on (READ DATES FROM QUESTION A4).

F1a. Last winter **before** your home was weatherized, was there ever a time when you wanted to use your fuel-oil heating system, but could not, for one or more of the following reasons?

	Yes	No
Your heating system was broken ?	[]	[]
You ran out of fuel oil?	[]	[]
The utility company discontinued your electric service?	[]	[]

IF "YES" TO ANY PART OF QUESTION F1A, ASK:

<p>F1b. Thinking about these times that you went without heat, last winter before weatherization, how many <u>separate</u> times were there?</p> <p style="margin-left: 40px;">Total times: _____</p>
<p>F1c. Altogether, how many hours or days were you without heat?</p> <p style="margin-left: 40px;">Total hours without heat: _____</p> <p style="text-align: center; margin-left: 80px;">OR</p> <p style="margin-left: 40px;">Total days without heat: _____</p>

F2a. Last winter **after** your home was weatherized was there ever a time when you wanted to use your fuel-oil heating system, but could not, for one or more of the following reasons?

	Yes	No
Your heating system was broken ?	[]	[]
You ran out of fuel oil?.	[]	[]
The utility company discontinued your electric service?	[]	[]

IF "YES" TO ANY PART OF QUESTION F2A, ASK:

F2b. Thinking about these times that you went without heat, last winter **after** weatherization, how many separate times were there?

Total times: _____

F2c. Altogether, how many hours or days were you without heat?

Total hours without heat: _____

OR

Total days without heat: _____

F3. Except for the weatherization of your home on (READ DATES FROM QUESTION A4), was any home repair or major house renovation that would affect energy use done on your home by yourself or other organization between November 1990 and April 1991?

- Yes
- No (GO TO QUESTION F6)
- DON'T KNOW (GO TO QUESTION F6)

IF YES ON QUESTION F3, ASK:

F4. Please describe the home repair or renovation. (RECORD VERBATIM BELOW.)	
	MONTH
(1) _____ _____	_____ _____
(2) _____ _____	_____ _____
(3) _____ _____	_____ _____
(4) _____ _____	_____ _____

F5. In which month was the work done? (RECORD UNDER COLUMN FOR MONTH ABOVE.)

Now I'm going to ask you to describe the number of people in your home during the 1990 Thanksgiving holiday period and the Christmas holiday period compared to the rest of the winter. By number of people in your home I am referring to overnight visiting not visiting for meals or parties.

- F6. Please look at Exhibit F6. First, how did the number of people in your home during the 1990 Thanksgiving holiday and weekend compare to other parts of the winter? (PROBE IF NEEDED: By number of people in your home I am referring to overnight visiting not visiting for meals or parties.)

- Fewer people than other parts of the winter
- About the same number of people as other parts of the winter
- More people than other parts of the winter
- DON'T KNOW/DON'T REMEMBER

- F7. Please look at Exhibit F6 again. And how did the number of people in your home during the 1990 Christmas holiday through New Year's compare to the other parts of the winter? (PROBE IF NEEDED: By number of people in your home I am referring to overnight visiting not visiting for meals or parties.)

- Fewer people than other parts of the winter
- About the same number of people as other parts of the winter
- More people than other parts of the winter
- DON'T KNOW/DON'T REMEMBER

G. Impacts on Health, Safety, Comfort, Affordability

My next questions ask for your opinion about how weatherization affected the health, safety, comfort, and value of your home.

- G1a. Please look at Scale G1. Using a scale of 1 to 7, where 1 is too cold, 4 is comfortable, and 7 is too hot, how would you rate the temperature in your home last winter **before** weatherization?

BEFORE

1	2	3	4	5	6	7	8
too cold			comfortable			too hot	DON'T REMEMBER

IF 1-3 OR 5-7 ON QUESTION G1A, ASK:

- G1b. Why couldn't you keep your home the temperature you preferred last winter **before** weatherization? (DO NOT READ ANSWER CATEGORIES.) (CHECK ALL THAT APPLY.)*

- Heating system problem
- Landlord controls the temperature
- Difference of opinion in household
- Fuel shortage
- High cost of fuel
- Construction problem, such as broken windows, or holes in walls
- Other (please specify) _____

NOT SURE _____

- G1c. Using the same scale (REPEAT SCALE IF NECESSARY) how would you rate the temperature in your home last winter **after** weatherization?

AFTER

1	2	3	4	5	6	7	8
too cold			comfortable			too hot	DON'T REMEMBER

IF 1-3 OR 5-7 ON QUESTION G1C, ASK:

- G1d. Why couldn't you keep your home the temperature you preferred last winter **after** weatherization? (DO NOT READ ANSWER CATEGORIES.) (CHECK ALL THAT APPLY.)*

- Heating system problem
- Landlord controls the temperature
- Difference of opinion in household
- Fuel shortage
- High cost of fuel
- Construction problem such as broken windows, or holes in walls
- Other (please specify) _____

NOT SURE _____

version 18C
5/10/91

Interviewer _____

Date of Interview _____

Time Started _____

FUEL-OIL STUDY OCCUPANT QUESTIONNAIRE CONTROL HOME

A. Identification

INTERVIEWER INSTRUCTIONS:

Complete Questions A1 and A2 using data from the information sheet before starting the interview.

A1. Household Identifier _____

A2. Name of WAP Applicant _____

SCREENER:

ASK TO SPEAK TO THE APPLICANT NAMED IN QUESTION A2. IF AVAILABLE, READ THE FOLLOWING AND GO TO QUESTION A3.

Your home will be weatherized soon as a participant in the Weatherization Assistance Program. We would like to conduct an interview to learn more about your energy use.

IF THE APPLICANT NAMED IN QUESTION A2 IS NOT AVAILABLE, READ THE FOLLOWING AND THEN ASK QUESTION 1:

Your home will be weatherized soon as a participant in the Weatherization Assistance Program. We would like to conduct an interview to learn more about your energy use.

1: I'd like to speak to a person over eighteen years of age who is knowledgeable about paying the energy bills. Is that person available? (IN ORDER TO QUALIFY, THE RESPONDENT DOES NOT HAVE TO PAY THE CHECK. AS LONG AS THE RESPONDENT IS KNOWLEDGEABLE ABOUT THE ENERGY USE AND/OR BILLS, HE OR SHE QUALIFIES.)

1. YES, THE PERSON YOU ARE SPEAKING TO IS THE RESPONDENT. CONTINUE WITH QUESTION A3.

2. YES, RESPONDENT IS ANOTHER PERSON. ONCE A RESPONDENT IS PRESENT, RETURN TO THE INTRODUCTION AND CONFIRM THAT THE RESPONDENT IS OVER 18 AND IS KNOWLEDGEABLE ABOUT PAYING THE ENERGY BILLS. IF THE RESPONDENT QUALIFIES, CONTINUE WITH QUESTION A3.

3. NO, RESPONDENT IS NOT AVAILABLE. (NAMES: _____) IDENTIFY NAMES OF SEVERAL PEOPLE WHO MIGHT BE SUITABLE RESPONDENTS. INFORM THE CURRENT RESPONDENT THAT WE WILL CONDUCT THE INTERVIEW OVER THE TELEPHONE AT A LATER DATE. LEAVE A COPY OF THE EXHIBITS AT THE HOUSE. DO NOT PROCEED WITH THE INTERVIEW.

INTERVIEWER INSTRUCTIONS:
IF RESPONDENT NEEDS INFO: The survey is a part of the Weatherization Assistance Program. The survey is required of every participant in the Fuel Oil Study.
IF RESPONDENT IS HESITANT: Your answers to these questions will provide valuable information to the Department of Energy. The interview will take approximately 30 minutes.

A3. Name of respondent _____
Relation to WAP contact _____
 RESPONDENT IS SAME AS WAP CONTACT

A3a. Has any weatherization work been done to your home by the Weatherization Assistance program before April 1991?

No (GO TO QUESTION A4)

Yes (PROBE AND INSPECT HOME, IF WEATHERIZED BY WAP, SWITCH TO WEATHERIZED HOME QUESTIONNAIRE.)

INTERVIEWER INSTRUCTIONS:

If respondent has trouble remembering the dates in Questions A4, A5, and A6, probe for:

- Season
- Major life event
- Major news story or political event happening at that time

Then, ask for year (and month) again.

A4. In what year was this home built? Just your estimate.*

- | | | |
|--------------------------------------|------------------------------------|-------------------------------|
| <input type="checkbox"/> Before 1900 | <input type="checkbox"/> 1940-1949 | <input type="checkbox"/> 1985 |
| <input type="checkbox"/> 1900-1909 | <input type="checkbox"/> 1950-1959 | <input type="checkbox"/> 1986 |
| <input type="checkbox"/> 1910-1919 | <input type="checkbox"/> 1960-1969 | <input type="checkbox"/> 1987 |
| <input type="checkbox"/> 1920-1929 | <input type="checkbox"/> 1970-1979 | <input type="checkbox"/> 1988 |
| <input type="checkbox"/> 1930-1939 | <input type="checkbox"/> 1980-1984 | <input type="checkbox"/> 1989 |
| | | <input type="checkbox"/> 1990 |

A5. In what year did your family move into this home?*

- | | | |
|--------------------------------------|------------------------------------|-------------------------------|
| <input type="checkbox"/> Before 1900 | <input type="checkbox"/> 1940-1949 | <input type="checkbox"/> 1985 |
| <input type="checkbox"/> 1900-1909 | <input type="checkbox"/> 1950-1959 | <input type="checkbox"/> 1986 |
| <input type="checkbox"/> 1910-1919 | <input type="checkbox"/> 1960-1969 | <input type="checkbox"/> 1987 |
| <input type="checkbox"/> 1920-1929 | <input type="checkbox"/> 1970-1979 | <input type="checkbox"/> 1988 |
| <input type="checkbox"/> 1930-1939 | <input type="checkbox"/> 1980-1984 | <input type="checkbox"/> 1989 |
| | | <input type="checkbox"/> 1990 |

IF "1989" OR LATER ON QUESTION A5, ASK:

A6. In which month did you move in?*

- | | | |
|-----------------------------------|---------------------------------|------------------------------------|
| <input type="checkbox"/> January | <input type="checkbox"/> May | <input type="checkbox"/> September |
| <input type="checkbox"/> February | <input type="checkbox"/> June | <input type="checkbox"/> October |
| <input type="checkbox"/> March | <input type="checkbox"/> July | <input type="checkbox"/> November |
| <input type="checkbox"/> April | <input type="checkbox"/> August | <input type="checkbox"/> December |

B. Major Heating Fuel

Next, I will ask some questions about the fuels you used to heat your home last winter before January 1991 and after January 1991. Throughout the survey, when I ask about last winter before January 1991, I mean October, November, and December of 1990. When I ask about last winter after January 1991, I mean February, March, and April of 1991. We are asking about these time frames because other houses being studied were weatherized in January 1991.

INTERVIEWER INSTRUCTIONS:
 If two or more heating fuels are used, the **main heating fuel** is the one that provides most of the heat for the home. The main heating fuel may not necessarily be the one used for the central heating system.

(HAND RESPONDENT EXHIBIT BOOKLET)

B1. Please look at Exhibit B1. What was the **one main heating fuel** used for heating your home last winter before January 1991?*

	B1 Main Fuel <u>(Mark only one)</u>	B2 (Mark all other fuels that apply)
Gas from underground pipes serving the neighborhood.	<input type="checkbox"/>	<input type="checkbox"/>
Bottled gas (LPG or Propane).	<input type="checkbox"/>	<input type="checkbox"/>
Fuel oil.	<input type="checkbox"/>	<input type="checkbox"/>
Kerosene or coal oil.	<input type="checkbox"/>	<input type="checkbox"/>
Electricity.	<input type="checkbox"/>	<input type="checkbox"/>
Coal or coke.	<input type="checkbox"/>	<input type="checkbox"/>
Wood.	<input type="checkbox"/>	<input type="checkbox"/>
Solar collectors.	<input type="checkbox"/>	<input type="checkbox"/>
Other (specify) _____	<input type="checkbox"/>	<input type="checkbox"/>
NO FUELS USED.	<input type="checkbox"/>	<input type="checkbox"/>
DON'T KNOW.	<input type="checkbox"/>	<input type="checkbox"/>

B2. Please look at Exhibit B1 again. You mentioned that your **main heating fuel** used last winter before January 1991 was (FUEL FROM QUESTION B1). What **other fuels** were used to heat your home last winter before January 1991 -- including those used to provide heat just occasionally? Don't forget to include fuels that ran portable heaters if you used them. (MARK ALL THAT APPLY IN COLUMN B2. IF NONE, MARK "NO FUELS USED")*

IF ADDITIONAL FUELS ARE IDENTIFIED FROM QUESTION B2, ASK:

B3. Going back to your **main heating fuel** used last winter before January 1991 -- (FUEL FROM QUESTION B1) -- did this fuel provide all or almost all of the heat for your home, about three-fourths, or closer to half of the heat for your home?*

All or almost all (95% or more)
 About three-fourths (67-94%)
 Closer to half (66% or less)
 DON'T KNOW/REMEMBER

Now, I will ask similar questions about the fuels you used last winter after January 1991.

B4. Please look at Exhibit B1 again. What was the **one main heating fuel** used for heating your home last winter after January 1991?*

	B4 Main Fuel (Mark only one)	B5 (Mark all other fuels that apply)
Gas from underground pipes serving the neighborhood.	[]	[]
Bottled gas (LPG or Propane).	[]	[]
Fuel oil.	[]	[]
Kerosene or coal oil.	[]	[]
Electricity.	[]	[]
Coal or coke.	[]	[]
Wood.	[]	[]
Solar collectors.	[]	[]
Other (specify) _____	[]	[]
NO FUELS USED.	[]	[]
DON'T KNOW.	[]	[]

B5. Please look at Exhibit B1 again. You mentioned that your **main heating fuel** used last winter after January 1991, was (FUEL FROM QUESTION B4). What **other** fuels were used to heat your home last winter after January 1991 -- including those used to provide heat just occasionally? Don't forget to include fuels that ran portable heaters if you used them. (MARK ALL THAT APPLY IN COLUMN B5. IF NONE, MARK "NO FUELS USED")*

IF ADDITIONAL FUELS ARE IDENTIFIED FROM QUESTION B5, ASK:

B6. Going back to your **main heating fuel** used last winter after January 1991 -- (FUEL FROM QUESTION B4) -- did this fuel provide all or almost all of the heat for your home, about three-fourths, or closer to half of the heat for your home?*

- [] All or almost all (95% or more)
- [] About three-fourths (67-94%)
- [] Closer to half (66% or less)
- [] DON'T KNOW/REMEMBER

B7a. Please look at Exhibit B7. Last winter **before** January 1991, did you use any of the following to **help** heat your home? (CHECK AS MANY AS WERE USED.)

(B7a) <u>BEFORE</u>	(B7b) <u>AFTER</u>
<input type="checkbox"/> Wood/coal stove.	<input type="checkbox"/>
<input type="checkbox"/> Fireplace.	<input type="checkbox"/>
<input type="checkbox"/> Cooking stove/range/oven.	<input type="checkbox"/>
<input type="checkbox"/> Non-portable room heater burning gas, oil, or kerosene.	<input type="checkbox"/>
<input type="checkbox"/> Portable kerosene heater.	<input type="checkbox"/>
<input type="checkbox"/> Non-portable electric heater.	<input type="checkbox"/>
<input type="checkbox"/> Electric portable heater (cord-connected).	<input type="checkbox"/>
<input type="checkbox"/> Other (specify): _____	<input type="checkbox"/>
<input type="checkbox"/> NONE.	<input type="checkbox"/>

B7b. Please look at Exhibit B7 again. Last winter **after** January 1991, did you use any of the following to **help** heat your home? (CHECK AS MANY AS WERE USED IN COLUMN B7b.)

INTERVIEWER INSTRUCTIONS:

Confirm that responses to B7a do not contradict responses to B1 and B2. Confirm that responses to B7b do not contradict responses to B4 and B5. Probe the respondent if the responses contradict.

ASK QUESTION B8 ONLY FOR EACH ITEM IN QUESTION B7 USED BOTH BEFORE AND AFTER JANUARY 1991:

B8. Please turn to Exhibit B8. Please tell me how often you used the following to help heat your home last winter **after** January 1991 as compared to last winter before January 1991. Did you use it less, about the same, or more after January 1991 as compared to before January 1991? (CIRCLE ONE NUMBER IN EACH LINE ASKED.)

	Used Less <u>After</u>	Used About <u>The Same</u>	Used More <u>After</u>
1. Wood/coal stove	1	2	3
2. Fireplace	1	2	3
3. Cooking stove/range/oven	1	2	3
4. Non-portable room heater burning gas, oil, or kerosene	1	2	3
5. Portable kerosene heater	1	2	3
6. Non-portable electric heater	1	2	3
7. Electric portable heater (cord-connected)	1	2	3
8. Other (_____)	1	2	3

C. Demographics

Now I have some questions about the people who live here and about your housing costs.

- C1. Please tell me how many people living in your home last winter **before** January 1991 were . . . (READ EACH ITEM).

Under the age of 5	_____
Between 5 and 17 years old	_____
Between 18 and 64 years old	_____
65 years old or older	_____

TALLY -- so that is (READ NUMBER) in total?

ENTER CORRECT TOTAL HERE

- C2. You have told me that there were (READ TOTAL NUMBER FROM QUESTION C1) people living in your home last winter **before** January 1991. How many people were living in your home last winter **after** January 1991?

NUMBER OF RESIDENTS

[] SAME NUMBER AFTER JANUARY 1991 AS BEFORE JANUARY 1991

- C3. Were any of the people living in your home last winter **before** January 1991 handicapped? By handicapped, I mean a permanent condition. I do not mean a temporary condition, such as a short-term illness. (EYEGLASSES ARE NOT CONSIDERED A HANDICAP). (IF YES, ASK HOW MANY.)

NUMBER HANDICAPPED

C4. Do you or members of your household own your home, or rent?*

- Own (buying)
- Rent
- Occupied without payment of rent (SKIP TO SECTION D)

FROM QUESTION C4, IF HOUSEHOLD OWNS OR PAYS RENT, ASK:

C5. Please tell me which category best describes the monthly rent or mortgage payment the household pays for your home. Is it . . . ? Stop me when I reach the category. (READ CATEGORIES.)

- less than \$200 per month
- \$201 - 300 per month
- \$301 - 400 per month
- \$401 - 500 per month
- \$501 - 600 per month
- \$601 - 700 per month
- \$701 - 800 per month
- \$801 - 900 per month
- more than \$900 per month
- OWNED, MORTGAGE PAID OFF (SKIP TO SECTION D)
- DON'T KNOW

C6. Does this payment include: (READ ITEMS AND PROBE FOR "YES" OR "NO".)

	Yes	No	DON'T KNOW
1. fuel oil.	<input type="checkbox"/>	<input type="checkbox"/>	<input type="checkbox"/>
2. electricity.	<input type="checkbox"/>	<input type="checkbox"/>	<input type="checkbox"/>
3. natural gas.	<input type="checkbox"/>	<input type="checkbox"/>	<input type="checkbox"/>
4. property tax.	<input type="checkbox"/>	<input type="checkbox"/>	<input type="checkbox"/>
5. insurance (house or renter's).	<input type="checkbox"/>	<input type="checkbox"/>	<input type="checkbox"/>
6. water.	<input type="checkbox"/>	<input type="checkbox"/>	<input type="checkbox"/>
7. garbage.	<input type="checkbox"/>	<input type="checkbox"/>	<input type="checkbox"/>
8. other (specify): _____	<input type="checkbox"/>	<input type="checkbox"/>	<input type="checkbox"/>

D. Conditioned Living Space

My next question is about the number of different types of rooms in your home. Remember that when I ask about last winter before January 1991, I mean October, November, and December of 1990. When I ask about last winter after January 1991, I mean February, March, and April of 1991.

INTERVIEWER INSTRUCTIONS:

For one-bedroom efficiency or studio apartment, record "0 bedrooms" and number of bathrooms and other rooms.

Full Bathroom -- sink with running water **and** flush toilet **and** bathtub or shower.

Half Bathroom -- toilet **or** bathtub **or** shower

D1. How many of each of the following rooms does this home have? (ASK EACH ITEM AND RECORD NUMBER FOR EACH.)*

	<u>D1</u> Total Number	<u>D2A</u> Number heated last winter before January 1991	<u>D2B</u> Number heated last winter after January 1991
Bedrooms?	_____	_____	_____
Full bathrooms?	_____	_____	_____
Half bathrooms?	_____	_____	_____
All other rooms: (Do not count laundry rooms, foyers or unfinished storage space. Only count porches if they are enclosed and used year-round.)	_____	_____	_____

D2. (FOR EACH TYPE OF ROOM THE RESPONDENT HAS IN THE HOME, ASK D2A, THEN D2B. A HEATED ROOM IS ONE THAT IS WARM ENOUGH TO BE USED.)

D2a. Of the (READ NUMBER OF ROOMS AND TYPE OF ROOM), how many were heated last winter **before** January 1991 (RECORD ABOVE ON COLUMN D2A.)

D2b. And how many (READ TYPE OF ROOM) were heated last winter **after** January 1991? (RECORD ABOVE ON COLUMN D2B.)

E. Thermostat Management

I would now like to ask you some questions about the temperature at which you kept your home

INTERVIEWER INSTRUCTIONS:

Remember, we are interested in the respondent's perceptions. Ask the respondent for their opinion; avoid checking the thermostat for the actual settings.

If respondent keeps different sections of the home at different temperatures, we want to know the temperature in the part of the house where the people are. If, for example, the heat is turned off upstairs during the day because the family is downstairs, we want the downstairs temperature.

We would like to know the actual temperature of the home. If the respondent doesn't know the temperature, but does know the thermostat setting, record the thermostat setting. Otherwise, probe for best estimate.

E1a. Last winter before January 1991, did you keep your home at the same temperature at all times of the day, or did you change the temperature?

- Kept home at same temperature (ASK QUESTION E1B)
 Changed the temperature (GO TO QUESTION E1C)

IF KEPT HOME AT SAME TEMPERATURE ON QUESTION E1A, ASK:

E1b. Before January 1991, at what temperature did you usually keep your home?

Degrees Fahrenheit: _____
 HEAT TURNED OFF

(GO TO QUESTION E2A)

IF CHANGED THE TEMPERATURE ON QUESTION E1A, ASK:

E1c. Before January 1991, at what temperature did you usually keep your home during the day when someone was at home?*

Degrees Fahrenheit: _____
 HEAT TURNED OFF

E1d. Before January 1991, at what temperature did you usually keep your home during the day when no one was at home?*

Degrees Fahrenheit: _____
 HEAT TURNED OFF

E1e. Before January 1991, at what temperature did you usually keep your home during sleeping hours?*

Degrees Fahrenheit: _____
 HEAT TURNED OFF

(ASK EVERYONE:)

E2a. Last winter **after** January 1991, did you keep your home at the same temperature at all times of the day, or did you change the temperature?

- Kept home at same temperature (ASK QUESTION E2B)
 Changed the temperature (GO TO QUESTION E2C)

IF KEPT HOME AT SAME TEMPERATURE ON QUESTION E2A, ASK:

E2b. **After** January 1991, at what temperature did you **usually** keep your home?

Degrees Fahrenheit: _____

HEAT TURNED OFF

(GO TO SECTION F)

IF CHANGED THE TEMPERATURE ON QUESTION E2A, ASK:

E2c. **After** January 1991, at what temperature did you **usually** keep your home during the day **when someone was at home?***

Degrees Fahrenheit: _____

HEAT TURNED OFF

E2d. **After** January 1991, at what temperature did you **usually** keep your home during the day **when no one was at home?***

Degrees Fahrenheit: _____

HEAT TURNED OFF

E2e. **After** January 1991, at what temperature did you **usually** keep your home **during sleeping hours?***

Degrees Fahrenheit: _____

HEAT TURNED OFF

F. Events Affecting Energy Use

The next questions are about events which may have affected your energy use last winter. (REMIND RESPONDENT IF NECESSARY): Remember that when I ask about last winter before January 1991, I mean October, November, and December of 1990. When I ask about last winter after January 1991, I mean February, March, and April of 1991.

F1a. Last winter before January 1991, was there ever a time when you wanted to use your fuel-oil heating system, but could not, for one or more of the following reasons?

	Yes	No
Your heating system was broken?	<input type="checkbox"/>	<input type="checkbox"/>
You ran out of fuel oil?	<input type="checkbox"/>	<input type="checkbox"/>
The utility company discontinued your electric service?	<input type="checkbox"/>	<input type="checkbox"/>

IF "YES" TO ANY PART OF QUESTION F1A, ASK:

F1b. Thinking about these times that you went without heat, last winter before January 1991, how many separate times were there?

Total times: _____

F1c. Altogether, how many hours or days were you without heat?

Total hours without heat: _____

OR

Total days without heat: _____

F2a. Last winter **after** January 1991, was there ever a time when you wanted to use your fuel-oil heating system, but could not, for one or more of the following reasons?

	Yes	No
Your heating system was broken ?.....	<input type="checkbox"/>	<input type="checkbox"/>
You ran out of fuel oil?.....	<input type="checkbox"/>	<input type="checkbox"/>
The utility company discontinued your electric service?	<input type="checkbox"/>	<input type="checkbox"/>

IF "YES" TO ANY PART OF QUESTION F2A, ASK:

F2b. Thinking about these times that your went without heat, last winter **after** January 1991, how many separate times were there?

Total times: _____

F2c. Altogether, how many hours or days were you without heat?

Total hours without heat: _____

OR

Total days without heat: _____

F3. Was any home repair or major house renovation that would affect energy use done on your home by yourself or other organization between November 1990 and April 1991?

- Yes
- No (GO TO QUESTION F6)
- DON'T KNOW (GO TO QUESTION F6)

IF YES ON QUESTION F3, ASK:

F4. Please describe the home repair or renovation. (RECORD VERBATIM BELOW.)

	MONTH
(1) _____ _____	_____
(2) _____ _____	_____
(3) _____ _____	_____
(4) _____ _____	_____

F5. In which month was the work done? (RECORD UNDER COLUMN FOR MONTH ABOVE.)

Now I'm going to ask you to describe the number of people in your home during the 1990 Thanksgiving holiday period and the Christmas holiday period compared to the rest of the winter. By number of people in your home I am referring to overnight visiting not visiting for meals or parties.

- F6. Please look at Exhibit F6. First, how did the number of people in your home during the 1990 Thanksgiving holiday and weekend compare to other parts of the winter? (PROBE IF NEEDED: By number of people in your home I am referring to **overnight** visiting **not** visiting for meals or parties.)

- Fewer people than other parts of the winter
- About the same number of people as other parts of the winter
- More people than other parts of the winter
- DON'T KNOW/DON'T REMEMBER

- F7. Please look at Exhibit F6 again. And how did the number of people in your home during the 1990 Christmas holiday through New Year's compare to the other parts of the winter? (PROBE IF NEEDED: By number of people in your home I am referring to **overnight** visiting **not** visiting for meals or parties.)

- Fewer people than other parts of the winter
- About the same number of people as other parts of the winter
- More people than other parts of the winter
- DON'T KNOW/DON'T REMEMBER

G. Impacts on Health, Safety, Comfort, Affordability

My next questions ask for your opinion about the health, safety, comfort, and value of your home.

- G1a. Please look at Scale G1. Using a scale of 1 to 7, where 1 is too cold, 4 is comfortable, and 7 is too hot, how would you rate the temperature in your home last winter before January 1991?

BEFORE

1	2	3	4	5	6	7	8
too cold			comfortable			too hot	DON'T REMEMBER

IF 1-3 OR 5-7 ON QUESTION G1A, ASK:

- G1b. Why couldn't you keep your home the temperature you preferred last winter before January 1991? (DO NOT READ ANSWER CATEGORIES.) (CHECK ALL THAT APPLY.)*

- Heating system problem
- Landlord controls the temperature
- Difference of opinion in household
- Fuel shortage
- High cost of fuel
- Construction problem, such as broken windows, or holes in walls
- Other (please specify) _____

NOT SURE _____

- G1c. Using the same scale (REPEAT SCALE IF NECESSARY) how would you rate the temperature in your home last winter after January 1991?

AFTER

1	2	3	4	5	6	7	8
too cold			comfortable			too hot	DON'T REMEMBER

IF 1-3 OR 5-7 ON QUESTION G1C, ASK:

- G1d. Why couldn't you keep your home the temperature you preferred last winter after January 1991? (DO NOT READ ANSWER CATEGORIES.) (CHECK ALL THAT APPLY.)*

- Heating system problem
- Landlord controls the temperature
- Difference of opinion in household
- Fuel shortage
- High cost of fuel
- Construction problem such as broken windows, or holes in walls
- Other (please specify) _____

NOT SURE _____

G5. Please look at Scale G5. Using a scale of 1 to 7, where 1 is very expensive, 4 is acceptable, and 7 is very inexpensive, how would you rate the cost of your heating bills last winter before January 1991?

BEFORE
 1 2 3 4 5 6 7 8
 very expensive acceptable very inexpensive DON'T REMEMBER

Using the same scale (REPEAT SCALE IF NECESSARY), how would you rate the cost of your heating bills last winter after January 1991?

AFTER
 1 2 3 4 5 6 7 8
 very expensive acceptable very inexpensive DON'T REMEMBER

G6. Please look at Scale G6. Using a scale of 1 to 7, where 1 is very much lower, 4 is about the same, and 7 is very much higher, how would you rate the property value of your home after January 1991 as compared to before January 1991? By property value, I mean the dollar value of the home if sold.

1 2 3 4 5 6 7 8
 very much lower about the same very much higher DON'T REMEMBER

END

On behalf on the U.S. Department of Energy, I would like to thank you for your time and patience today. The information that you have shared with us will be helpful in our study.

*These items are modified versions of questions taken from the 1990 Residential Energy Consumption Survey (RECS) conducted by the Energy Information Administration.

INTERVIEWER INSTRUCTIONS:

Check to make sure each question has been answered and that verbatim responses are clear and legible.

TIME ENDED: _____

APPENDIX G. AIR-LEAKAGE MEASUREMENT TEST PROCEDURE

Air-leakage measurements will be made in all the houses before and after weatherization following this procedure.

Version: April 26, 1991

AIR-LEAKAGE MEASUREMENT TEST PROCEDURE

OBJECTIVE

The objectives of this procedure are to

1. provide the necessary measurements to calculate, for single-family houses, the air flow rate with the house depressurized 50Pa below ambient, the equivalent or effective leakage area¹, and air exchange rate¹ (if the number of conditioned stories is known);
2. examine the airtightness of the house as constructed, including all intentional and non-intentional openings in the envelope; and
3. ensure comparability of measurements performed by different contractors using different brands of blower doors.

Although this procedure does not fully comply with ASTM Standard E779-87² especially regarding pressurized measurements, it generally follows the principles contained in the standard.

PRE-TEST PROCEDURE

House Preparation

The house should be prepared for measurement as follows:

1. Close all fireplace and wood stove dampers, glass doors, and other flue openings. Have occupant extinguish all fires. Remove ashes or place wet cloths or newspapers over cold ashes.
2. Turn off exhaust fans, dryers, space-heating systems, water-heating systems, and gas-stoves.
3. Close all windows and exterior doors, including doors to garages and other such buffer spaces that are not heated. A heated space is defined to be a space with permanent space-heating equipment and/or distribution outlets designed to maintain a desired temperature in the space. A space (such as a basement) that is heated primarily from equipment jacket and/or distribution losses (there is little control over the resulting temperature) is not a heated space.

¹Handbook of Fundamentals, American Society of Heating, Refrigerating, and Air Conditioning Engineers, 1989.

²Standard Test Method for Determining Air Leakage Rate by Fan Pressurization, The American Society for Testing and Materials, 1987.

4. Open all interior doors (except for closets) so that all interior heated space is connected, including heated basements (if only portions of the basement are heated, open all doors necessary to connect these heated basement areas with other heated areas). If a space was designed to be a heated space but is maintained by the occupant in an unheated condition, the space should still be considered a heated space with one exception: an unfinished basement or other unfinished room with a distribution system that is always closed off should not be considered a heated space.
5. Record on the Blower-Door Test Data Sheet the exclusion/inclusion of buffer spaces, zoned rooms, and basements in order that the post-weatherization test can be performed on the same heated space of the house.

Equipment Set-Up

All equipment should be kept at as close to 70°F as possible while in transit and brought into the house immediately upon arrival. Equipment should be set-up as specified below.

1. Deploy a thermometer outside away from the door in a shaded area, and one inside in the same room as the blower door.
2. Zero the gauge to be used to measure air flow through the fan after removing all hoses from the gauge so that both pressure taps are exposed to room air.
3. Install the fan on an exterior door for depressurizing the house. The chosen door must be free of wind interference and obstructions for at least 4 ft upstream of the fan. Install the hose measuring the outside pressure out of line of the blower-door fan. Multiple outside hoses or pressure equalizing boxes must not be used. Set up the gauges inside the house and out of the direct flow of air through the blower-door fan (if a hose is used to measure the inside pressure, ensure that it is out of the direct flow of air as well). Check all hose fittings for tightness and trim or tighten as necessary. Connect all hoses. Check for leaks around the fan and door.
4. The gauge used to measure pressure difference across the house envelope is zeroed to remove the natural pressure difference that may exist between the inside and outside of the house due to thermal or wind effects. Cover the fan opening (using the "shower cap" provided by the manufacturer, plugging or taping all holes with the orifice plate on, or some other equivalent technique). Zero the gauge. Remove the fan opening cover. Re-zero the gauge in this manner each time a new run is started.
5. Briefly walk through the house while maintaining a negative pressure difference across the house of 20-40 Pa to check for previously undetected operable openings in the envelope (i.e. open windows, attic hatches, dampers) and other significant sources of air leakage. Identify on the Blower-Door Test Data Sheet any unusual sources of air leakage. Also, look for indications of weak areas (ceilings, windows) that could be damaged with increased negative pressures.
6. Establish a negative pressure difference across the house of 50 Pa for 15 seconds. Do not pressurize the house after this step.

TEST PROCEDURE

Starting the Test

1. Record the identification number of the blower door so that the same door can be used for future tests.
2. Record the indoor and outdoor temperatures.
3. Record the average wind speed, maximum wind gust, and location of the wind measurement (so that same spot can be used for future tests). The measuring device should be deployed three to five building heights away from buildings and other major obstructions and be faced into the wind. Average wind speed should generally not exceed 10 mph; greater speeds and gusty wind conditions can cause difficulty in obtaining quality air-leakage measurements.
4. Record the local shielding class.

Pressure Station Measurements

A test entails making measurements at all pressure stations identified on the Blower-Door Test Data Sheet unless the maximum pressure generated by the fan is insufficient. In this case, make measurements at as many of the assigned pressure stations as possible. Make measurements starting at the lowest pressure station and proceeding in ascending order.

Orifice Plates

For blower doors with orifice plates, at least one (and possibly two) changes in orifice plates should be expected during any particular test. The number and size of orifice plates used must be recorded with each pressure station.

1. The initial orifice plate should be the smallest allowed by the blower-door manufacturer. Using this plate, attempt to make a measurement at the first pressure station. If this is not possible, move to the next larger orifice until the measurement can be made.
2. As measurements are made at higher pressure stations, change to the next largest orifice plate only when it is no longer possible to reach 5 Pa above the desired pressure station.

Gauge Reading Procedures

1. To make a measurement at each pressure station, first raise the house to about 5 Pa above the desired pressure. Then slowly reduce the pressure until the desired pressure is reached. If the pressure is undershot, raise the pressure again to 5 Pa over the desired pressure and repeat the process.
2. Tap the gauges continuously while adjusting the pressure down to the desired station as the stored spring energy will cause the gauge needles to jump slightly.

3. Set the gauge needle on the indicated pressure stations, within ± 2 Pa.
4. Wait 30 seconds for the blower-door readings to stabilize. Record the actual house pressure reading, the fan pressure or flow rate reading, and the orifice configuration on the Blower-Door Test Data Sheet. When lining the gauge needle up with the marks on the gauge, read the gauge from directly in front to avoid parallax. Always take readings off of the gauge with the lowest range possible. For example, when measuring a flow pressure of less than 125 Pa, read from a gauge with a range of 0-125 Pa rather than from one with a range of 0-750 Pa. Note the reason for any alternate pressure station readings.

Acceptable Error Level

Input the data collected at eight of the nine pressure stations into the blower-door computer: do not use the 10 Pa data if a 60 Pa reading was made. The test must be repeated if the percent error in the flow data at each pressure station is more than 5%, the correlation coefficient is less than 0.99, or the flow exponent (n) is less than 0.5 or greater than 1.0. These numbers appear on the blower-door tape. Before re-doing a test, examine all hoses and fittings for leakage and carefully re-zero the gauges as these could be the cause of excessive error.

Completing the Test

1. Record the indoor temperature.
2. Return ventilation controls, vents, and thermostats to their original settings. Make sure all space- and water-heating systems are operating correctly. Make sure all pilot lights are lit. Close interior doors to restore the house to its original state.
3. The printout from each test must be included with the Blower-Door Test Data Sheet.
4. Extreme care must be taken in recording all data points as tests with unacceptable levels of accuracy must be repeated.

Version: April 26, 1991

Technician: _____

Date: _____

BLOWER-DOOR TEST DATA SHEET: INFILTEC BLOWER DOOR

House ID: _____ Subgrantee name: _____

Occupant name: _____ Phone number: _____

Occupant address: _____

Procedures to prepare house for test: Basement door _____ (closed or open)

Unusual sources of leakage: _____

Test equipment identification number: _____

Start	Indoor temperature (°F)		Outdoor temperature (°F)	Average wind speed (MPH)	Maximum wind gust (MPH)	Location of wind measurement	Local shielding class
	Finish						

Pressure station		Actual	Flow rate (cfm)	Orifice
Goal				
(Pa)	(inches of water)			
10	0.04			
15	0.06			
20	0.08			
25	0.10			
30	0.12			
35	0.14			
40	0.16			
50	0.20			
60	0.24			

Local shielding classes	
1	No obstructions or local shielding
2	Light local shielding; few obstructions, a few trees, or small shed
3	Moderate local shielding; some obstructions within two house heights, thick hedge, solid fence, or one neighboring house
4	Heavy shielding; obstructions around most of perimeter, building or trees within 30 ft in most directions; typical suburban shielding
5	Very heavy shielding; large obstructions surrounding perimeter within two house heights; typical downtown shielding

Notes:

APPENDIX H.
SPACE-HEATING SYSTEM STEADY-STATE EFFICIENCY
MEASUREMENT PROCEDURE

The steady-state efficiency of the space-heating system will be measured in all houses before and after weatherization following this procedure.

Version: April 11, 1991

SPACE-HEATING SYSTEM STEADY-STATE EFFICIENCY MEASUREMENT PROCEDURE

OBJECTIVE

The objectives of this procedure are to

1. provide the necessary measurements to calculate the steady-state efficiency of residential space-heating systems fueled by natural gas or fuel oil; and
2. ensure comparability of measurements performed by different contractors using different brands of combustion efficiency test equipment.

This procedure assumes that the combustion efficiency test equipment has been calibrated following the manufacturer's recommendations. The procedure also assumes the use of electronic test equipment (the procedure should be followed with modifications made as necessary if other types of equipment are used).

SET-UP PROCEDURE

1. When testing units in confined spaces, ensure there is adequate ventilation to exhaust any carbon monoxide or other toxic gases.
2. Set up the test equipment according to the manufacturer's instructions. Be sure all connections are tight. The equipment should be placed indoors for at least fifteen minutes to reach room temperature. If applicable, aspirate room air through the equipment for at least five minutes.
3. If applicable, calibrate the equipment to 20.9% oxygen in a well ventilated area.
4. Identify a location in the system's flue sufficiently large to insert the test probe. The location must be located upstream of any dampers or other sources of air entering the flue. If needed, a 5/16" hole should be drilled into the flue pipe as close to the breech as possible, leaving enough clearance for the probe assembly handle.
5. Install the probe into the flue pipe's test location following the manufacturer's instructions. Make sure all tubing and wiring are free of kinks and away from hot areas of the heating system.
6. Turn on the heating system and allow the system to operate for at least five minutes.
7. Record the type of test to be performed.
8. Record the identification number of the test equipment so that the same equipment can be used for future tests.

MEASUREMENTS

Record the following measurements on the Steady-State Efficiency Data Sheet when the oxygen and temperature measurements do not fluctuate over a one-minute interval (when the temperature measurement does not change more than 5°F):

1. Measure the percent oxygen in the flue gas following the manufacturer's instructions.
2. Measure the room and flue gas temperatures (or net stack temperature) following the manufacturer's instructions.
3. For heating systems using fuel oil, measure the smoke number following the manufacturer's instructions. When using smoke paper to make the measurements, comparisons to charts (scales) must be made in daylight or incandescent light (never fluorescent light). Two pieces of unused smoke paper must be placed behind the test paper to make a comparison because of the transparency of the smoke paper.

COMPLETING THE TEST

1. Turn off the heating system and allow metal parts to cool before removing test equipment.
2. If a hole was drilled into the flue pipe, seal the hole using plugs approved for this purpose.
3. Using charts provided with the test equipment, record the unadjusted steady-state efficiency of the system (disregarding any adjustments for smoke numbers) and, for fuel-oil systems, the adjusted efficiency.
4. Note the condition of the battery in battery-operated test equipment. If the voltage is low, be sure to charge the battery according to manufacturer's instructions.

Version: April 11, 1991

Technician: _____
Date: _____

FUEL-OIL STUDY STEADY-STATE EFFICIENCY DATA SHEET

House I.D.: _____ Subgrantee name: _____

Occupant name: _____ Phone number: _____

Occupant Address: _____

Type of test: Pre-weatherization _____ Post-weatherization _____

Test equipment identification number	
Percent oxygen reading	%
Net stack temperature, or	°F
Room temperature	°F
Flue gas temperature	°F
Unadjusted steady-state efficiency	%

For fuel-oil systems:	
Smoke number	
Adjusted steady-state efficiency	%
If the smoke number is: 1, 2, 3, 4, 5, 6, 7, 8, 9 subtract: 0, 0, 0, 1, 2, 3, 4, 6, 7	

Notes:

APPENDIX I.

OIL-FIRED SPACE- AND WATER-HEATING SYSTEM INSPECTION PROCEDURE

The safety and integrity of the space- and water-heating systems of all the houses will be evaluated during the post-weatherization period using this procedure.

Version: April 26, 1991

OIL-FIRED SPACE- AND WATER-HEATING SYSTEM INSPECTION PROCEDURE

OBJECTIVE

The objectives of this procedure are to

1. provide the necessary measurements and evaluations to assess the safety and integrity of oil-fired space-heating systems, and
2. provide the necessary measurements and evaluations to assess the safety and integrity of oil-fired domestic water-heating systems.

The procedure is limited to an inspection of the space- and water-heating systems. It does not address other safety or health issues related to the house such as radon levels, structural integrity, code violations, unsanitary conditions, and moisture problems.

The procedure is intended to be a data collection instrument only, with the intent being that an overall assessment of these systems will not be made until sometime after the information has been collected in the field. Some guidelines are provided in the procedure to help make immediate interpretations of the collected data. Guidelines regarding repairs or remedies are beyond the scope of this procedure. Unsafe conditions found while following this procedure should be forwarded immediately to the occupants and proper organization or authority.

The procedure was written assuming two separate oil-fired systems. If the domestic water-heating system uses another fuel or is an integral part of the space-heating system (tankless), then some parts of the procedure will not apply. In developing the procedure, the term furnace strictly refers to space-heating systems that heat and distribute air, and the term boiler refers to hydronic systems. A Fuel-Oil System Inspection Form is included as part of this procedure to record all observations and measured data. This form parallels the procedure with the exception of heat exchanger information which is grouped together on the form.

GENERAL SPACE-HEATING SYSTEM INSPECTION

Any cracks in the heat exchanger of an oil-fired forced-air or gravity furnace presents a dangerous situation as flue gasses can enter the hot-air supply system and be distributed throughout the house. Both visual and metered inspections of the heat exchanger will be performed, even though it is often difficult to spot cracks visually.

1. Identify the system type.
2. Check the on/off operation of the thermostat.
3. Determine if the space-heating system has its own emergency electrical cutoff switch.
4. Determine if all 117 VAC wiring is secure.
5. For a furnace, identify the fan on/off temperature settings. For a boiler, identify the operating setpoint temperature (hot water systems) or operating pressure (steam systems).
6. Determine if a high limit switch is present and identify its setting (their functionality will not be tested under this procedure).

7. Note the presence of any combustible materials, including urethane (flexible foam) pipe insulation, immediately adjacent to the flue pipe or too close to the heating system.
8. Note the presence of any asbestos insulation on the system.
9. For a forced-air or gravity furnace, visually inspect the heat exchanger for cracks with the furnace off. Use a strong light and mirror to see as much of the heat exchanger as possible. Pay special attention to all gaskets and joints between sections, and areas that could be damaged by a leaking humidifier.
10. While performing the draft or carbon monoxide measurements that follow, or in coordination with an efficiency measurement, measure the oxygen levels in the flue with the burner running just before and after the distribution blower turns on. A change of 1% (e.g., from 8% to 9%) may indicate a cracked heat exchanger. (Usually, the oxygen levels will stabilize within 30-60 seconds after the system is turned on and before the distribution blower turns on.)

GENERAL DOMESTIC WATER-HEATING SYSTEM INSPECTION

1. Identify the system and fuel type.
2. If fossil-fuel-fired, note the presence of any combustible materials, including urethane (flexible foam) insulation, immediately adjacent to the flue pipe or too close to the system.
3. Note the presence of a pressure relief valve on the system.
4. Note the hot water setpoint temperature.

LEAKING FUEL SOURCES

Even small leaks in fuel-oil lines are relatively easy to detect. The inspection for fuel-oil leaks will be accomplished visually and by noting any fuel-oil odors in the vicinity of the supply lines. Leaks in outdoor tanks can be difficult to detect, especially if the tank is buried. Therefore, only visual and odor detection methods will be used for above-ground tanks; underground tanks will not be evaluated. Propane or natural gas is often used for domestic water heating in a dwelling heated by fuel oil. Under this procedure, an inspection for combustible gas from such a water-heating system will be performed based on smell; use of a combustible gas analyzer would be an improvement to the procedure if available.

1. Visually inspect the fuel-oil supply line from the space-heating system to the supply tank. Note if there are any leaks as indicated by the presence of fuel on the floor or supply lines, or strong fuel-oil odors in the vicinity of the lines.
2. Visually inspect the fuel-oil supply line (if present) from the water-heating system to the supply tank. Note if there are any leaks as indicated by the presence of fuel on the floor or supply lines, or strong fuel-oil odors in the vicinity of the lines. If the system is heated by gas rather than fuel oil, a leak may be indicated if there are any gas odors in the vicinity of the system or gas lines.
3. Visually inspect the above ground supply tank (if present). Note if there are any leaks as indicated by the presence fuel oil on the ground or lines, abnormal corrosion, or strong fuel odors in the vicinity of the tank.
4. Visually inspect the fuel-oil supply line from the supply tank to determine if a filter and shutoff valve are present.

SPACE-HEATING DISTRIBUTION SYSTEM

1. Check the operation of the circulating fan or pump of non-gravity systems.
2. For a forced-air or gravity furnace, check the condition of air filters and the exiting temperature of the supply air.
3. For a boiler, check the operation of any zone valves and inspect the piping for leaks.
4. Check for the presence of any asbestos insulation on the distribution system.

FLUE AND CHIMNEY INSPECTION (SPACE- AND WATER-HEATING SYSTEMS)

1. Visually check the chimney from the ground outside the structure to ascertain overall soundness. If there is an indication of a serious problem, take a closer view from the roof if practical.
2. Determine if the chimney extends above the roof at least 2 ft and that there is 10 ft of horizontal clearance around the top of the chimney.
3. Inspect the chimney and flue pipes from inside the house. Note any obvious holes, leaks, and untight connections in either system.
4. Remove the flue pipe if practical and inspect the chimney using a flashlight and mirror. Note any debris or deposits of more than 1/4 inch thick on the inside of the chimney. Note the presence or absence of a flue liner.
5. For space-heating systems only, check for the existence and correct function (damper swings, has a counterweight, and opens when the system is firing) of the barometric damper.

SPACE- AND WATER-HEATING SYSTEM DRAFTS

Both the time necessary to establish a proper draft and the steady-state draft are important quantities. There usually is no problem if a draft is established within 30 seconds; the system should be examined if a draft takes between 30 and 180 seconds to be established; a problem likely exists if a draft takes longer than 180 seconds to become established. An acceptable steady-state draft depends upon the outside air temperature. In all cases, however, any spillage (backdrafting) from the flue to the room containing the system is unacceptable once the draft has been established. The following table may be used as a guide:

Outdoor temperature	Acceptable Draft	Unacceptable Draft
> 80 °F	-0.005 to -0.20 inches water	0 inches water or greater
between 30 °F and 80 °F	-0.01 to -0.20 inches water	-0.01 inches water or greater
< 30 °F	-0.02 to -0.20 inches water	-0.02 inches water or greater

In addition, if the room where the systems are located is maintained at a pressure 5 Pa less than ambient, backdrafting is a potential problem.

1. Turn off the space- and water-heating systems for at least 20 minutes.

2. Turn on all exhaust fans in the house (except whole house ventilation fans), including the clothes dryer if one is present. Close all interior doors and the door to the room containing the systems.
3. Measure the outdoor temperature.
4. Measure the draft of the systems between the breech and barometric damper with the distribution fan and systems off.
5. Turn on the space-heating system. Measure the time required for backdrafting to stop (for a draft to become established). Measure the draft of the system at the following intervals from the time the system was turned on: 30 seconds, 1 minute, 2 minutes, and 3 minutes. Use a smoke pencil to detect airflow.
6. With the space-heating system operating, measure the pressure difference between the room containing the systems and the outside. If the basement is depressurized more than 0.02 inches water (5 Pa) relative to the outside, than make a second measurement with the space-heating system off.
7. Turn the space-heating system off and the water-heating system on. Repeat steps 4 and 5 for the water-heating system.

CARBON MONOXIDE

Carbon monoxide (CO) is extremely dangerous since it is both odorless and colorless as well as being toxic. However, if emanating from an oil burner, CO will often be accompanied by other combustion gases and fuels which do emit odors. CO readings should be made with an appropriate meter following the manufacturer's instructions. Readings will be recorded in parts per million (ppm) and only after they have become reasonably stable.

Any levels of CO in the household proper above 40 ppm warrants a closer inspection of the space-heating system. A level of CO greater than 100 ppm in the flue gas signals that the oil burner should be inspected (higher CO levels may occur in gas-fired systems). High smoke numbers measured during an efficiency test will likely accompany high CO readings in oil-burning systems.

1. Turn the carbon monoxide monitoring instrument on and allow it to warm up for one minute. Carefully obtain a "zero" instrument reading outside the house away from any combustion sources (running automobile engines, lawn mowers, etc.) The meter will usually not read zero, so note the reading.
2. After turning on the space- and water-heating systems, measure the CO in both flue gases before the barometric damper (this step can be coordinated with an efficiency test if one is to be performed).
3. Measure the CO in the room containing the space-heating system within 5 feet of the system.
4. Measure the CO in the kitchen and living room (the living room is defined to be the main living area of the house, usually characterized by the room with a television in it). Note if a gas stove top, gas oven, or fossil-fueled space heater were operating during the tests. Note any flue-gas odors in the house (also determine if the occupants have noticed any odors in the house when the system is operating).
5. For a forced-air or gravity furnace, measure the CO in the register with the shortest ducting from the space-heating system.

Version: April 26, 1991

Inspector: _____

Date: _____

FUEL-OIL STUDY SYSTEM SAFETY INSPECTION FORM**IDENTIFICATION**

House ID: _____ Subgrantee name: _____

Occupant name: _____ Phone number: _____

Occupant address: _____

GENERAL SPACE-HEATING SYSTEM INSPECTION

Type (FAF-central forced-air furnace, GF-central gravity furnace, SB-steam boiler, HWBR-hot water boiler with radiators or convectors, HWBS-hot water boiler for slab heating)	
Thermostat on/off operating (Y,N)	
Electrical cutoff switch present (Y,N)	
Wiring secure (Y,N)	
Furnace fan on/off temperature switches present (Y,N,NA)	
If yes: Upper setting _____ °F Lower setting _____ °F	
Boiler operating temperature (°F or NA)	
High limit switch settings (none, °F, psi)	
Combustible materials near flue (Y,N)	
Asbestos insulation present on system (Y,N)	

GENERAL DOMESTIC WATER-HEATING SYSTEM INSPECTION

Type (SA-stand alone, T-tankless)	
Fuel (NG-natural gas, P-propane, O-oil, E-electricity)	
Combustible materials near flue (Y,N,NA)	
Pressure relief valve present (Y,N)	
Temperature setting (°F or NA) (record highest setting for electrically heated systems)	°F

House ID: _____

FUEL LEAKS

	Leak
Space-heating system supply line (Y,N)	
Water-heating system supply line (Y,N,NA)	
Above ground storage tank (Y,N,NA)	

Is a filter and shutoff valve present in the supply line leading from the storage tank? _____ (Y,N)

SPACE-HEATING DISTRIBUTION SYSTEM

Forced-air or gravity furnaces	
Circulating fan operating (Y,N,NA)	
Condition of air filters (N-none, C-clean, D-dirty, P-plugged)	
Exit temperature of supply air	°F

Boilers	
Circulating pump operating (Y,N,NA)	
Zone valves operating (Y,N,NA)	
Leaks exist (Y,N)	

Is asbestos insulation present on the distribution system? _____ (Y,N)

House ID: _____

FLUE AND CHIMNEY INSPECTION

	Space-heating system	Water-heating system
Structurally sound (Y,N,NA)		
Chimney extends > 2 ft above roof (Y,N,NA)		
Clearance at chimney top > 10 ft (Y,N,NA)		
Leaks exist (Y,N,NA)		
Thick debris present (Y,N,NA)		
Flue liner present (Y,N,NA)		
Barometric damper (space-heating systems only):		
Exists (Y,N)		
Functions correctly (Y,N,NA)		

SPACE- AND WATER-HEATING SYSTEM DRAFTS

Outdoor temperature: _____ °F	Space-heating system	Water-heating system
Draft with system off	in. water	in. water
Time to stop backdrafting	seconds	seconds
Draft with system on		
30 seconds	in. water	in. water
1 minute	in. water	in. water
2 minutes	in. water	in. water
3 minutes	in. water	in. water
Pressure difference between space-heating system room and outside (positive number indicates that the basement is depressurized relative to the outside):		
space-heating system on	in. water	
space-heating system off	in. water	

House ID: _____

CARBON MONOXIDE TESTING

Ambient	ppm
Space-heating system flue gas	ppm
Water-heating system flue gas	ppm
Five feet from space-heating system	ppm
Kitchen	ppm
Living room	ppm
Register (ppm or NA)	ppm
Were the following operating during the test:	
Gas stove top (Y,N)	
Gas oven (Y,N)	
Fossil-fuel space-heater (Y,N)	

HEAT EXCHANGER

Cracks observed visually (Y,N,NA)	
Percent oxygen reading before blower turns on	%
Percent oxygen reading after blower turns on	%
Flue gas odor noticed in house (Y,N,NA)	

COMMENTS

APPENDIX J.**FUEL-OIL STUDY WEATHERIZATION INFORMATION SURVEYS**

Information on the weatherizations performed in each of the weatherized houses (installation dates, ECMs installed, costs, etc.) and program and administration costs for each subgrantees will be collected using the first survey provided in this appendix. The second survey will be used to collect a more limited amount of information on the control houses.

Version 3
2/21/91

Form completed by: _____
Date: _____

FUEL-OIL STUDY WEATHERIZATION INFORMATION SURVEY

A. IDENTIFICATION

A1. House Identifier: (To be completed by ORNL) _____

A2. Subgrantee Name: _____

A3. Occupant Name: _____

A4. Occupant Phone Number: _____

A5. Occupant Address: _____

B. GENERAL INFORMATION

B1. What was the household's income on the application form at the time when its eligibility was verified for the services it received in the 1990 program year?

\$ _____

B2. Weatherization work was performed primarily in this house in January 1991. What were the exact start and stop dates for this work (month, day, and year)? (Dates for weatherization work performed at other times will be identified in Section G.)

Weatherization work started on _____.

Weatherization work was completed on _____.

B3. What electric utility company serviced this household and what was the household's utility account number?

Electric utility: _____.

Account number: _____.

C. WEATHERIZATION MEASURES INSTALLED

Please check any of the measures listed that were installed in this dwelling during the time period identified in Question B2. (Measures installed at other times will be identified in Section G.) Indicate whether they were installed by in-house crew or contractor. If measures that are not listed were installed, please describe them in the appropriate "Other" category.

	Installed by:	
	In-house crew	Contractor
C1. Insulation		
Attic Insulation (installed for the first time)	<input type="checkbox"/>	<input type="checkbox"/>
Attic Insulation (added to existing insulation)	<input type="checkbox"/>	<input type="checkbox"/>
*Wall Insulation (normal technique)	<input type="checkbox"/>	<input type="checkbox"/>
*Wall Insulation (high-density technique)	<input type="checkbox"/>	<input type="checkbox"/>
Floor Insulation	<input type="checkbox"/>	<input type="checkbox"/>
Rim or Band Joist Insulation	<input type="checkbox"/>	<input type="checkbox"/>
Other Envelope Insulation	<input type="checkbox"/>	<input type="checkbox"/>
(Specify: _____ _____)		

*The "normal technique" for installing wall insulation is characterized by blowing cellulose or fiberglass insulation into exterior wall cavities to average densities using a two-hole, gravity-blow installation method. The "high-density technique" is characterized by blowing cellulose insulation into exterior wall cavities to high densities using a one-hole, tube-fill installation method. Under the "high-density technique," special attention is focused on sealing air leakage sites while insulating the walls; air bypasses are identified during the installation process and sealed by plugging the air-leakage pathways with cellulose.

C2. Air Leakage Control		
General Caulking and Weatherstripping (door and window)	<input type="checkbox"/>	<input type="checkbox"/>
Air sealing, emphasizing by-passes with blower door testing)	<input type="checkbox"/>	<input type="checkbox"/>
Air sealing, emphasizing by-passes without blower door testing)	<input type="checkbox"/>	<input type="checkbox"/>
Distribution System	<input type="checkbox"/>	<input type="checkbox"/>
Other Infiltration Reduction	<input type="checkbox"/>	<input type="checkbox"/>
(Specify: _____ _____)		

Installed by:
 In-house crew Contractor

C3. Water Heating System

- Water Heater Tank Insulation.
- Entire Water Heating System Replacement.
- Pipe Insulation.
- Low Flow Shower Heads.
- Temperature Reduction.
- Other Water Heater Measures.

(Specify: _____
 _____)

C4. Structural Repairs (full or partial)

- Attic Ventilation.
- Roof.
- Doors.
- Replacement of doors.
- Windows/Glazing.
- Replacement of windows.
- Walls.
- Floor.
- Other Structural Repairs.

(Specify: _____
 _____)

C5. Windows and Doors

- Storm Windows (How many? _____).
- Storm Doors.
- Window Films or Shades.
- Other Window or Door Treatments.

(Specify: _____
 _____)

	Installed by:	
	In-house crew	Contractor
C6. Space Heating System		
Clean and Tune-up.	<input type="checkbox"/>	<input type="checkbox"/>
Entire Heating System Replacement.	<input type="checkbox"/>	<input type="checkbox"/>
Set-back Thermostat.	<input type="checkbox"/>	<input type="checkbox"/>
Heating System Component Retrofits.	<input type="checkbox"/>	<input type="checkbox"/>
(Specify: _____)		
Safety Problem Fixed.	<input type="checkbox"/>	<input type="checkbox"/>
(Specify: _____)		
Repairs.	<input type="checkbox"/>	<input type="checkbox"/>
(Specify: _____)		
Other Heating System Modifications.	<input type="checkbox"/>	<input type="checkbox"/>
(Specify: _____ _____)		
C7. Space Cooling System		
Tune-up.	<input type="checkbox"/>	<input type="checkbox"/>
(e.g., cleaning, controls adjustment, filter replaced)		
Entire Air-conditioning System Replacement	<input type="checkbox"/>	<input type="checkbox"/>
Fans Installed or Replaced.	<input type="checkbox"/>	<input type="checkbox"/>
Set-back Thermostat.	<input type="checkbox"/>	<input type="checkbox"/>
Other Cooling System Modifications.	<input type="checkbox"/>	<input type="checkbox"/>
(Specify: _____ _____)		
C8. Other Health and Safety Repairs or Improvements		
Smoke Detectors.	<input type="checkbox"/>	<input type="checkbox"/>
Radon Testing.	<input type="checkbox"/>	<input type="checkbox"/>
Carbon Monoxide Testing.	<input type="checkbox"/>	<input type="checkbox"/>
Other.	<input type="checkbox"/>	<input type="checkbox"/>
(Specify: _____ _____)		

D. SERVICE DELIVERY PROCEDURES

Selection of Measures

D1. Please check the type of procedure that was used to select the measures that were installed in this dwelling during the time period identified in Question B2. (CHECK ALL THAT APPLY)

- Envelope measures were selected using a priority list (i.e., a checklist or prescribed list of measures)
- Envelope measures were selected using a decision approach or scoring (calculation) developed for each house
- Envelope measures were selected based on an analysis of energy savings per dollar invested
- Space-heating system measures were selected based on physical characteristics or a standard approach
- Space-heating system measures were selected using a decision approach or scoring (calculations) based on operating performance
- Space-heating system measures were selected based on an analysis of energy savings per dollar invested
- Selection of envelope and space-heating system measures was made simultaneously under one approach rather than separately using two distinct procedures.
- Other measure selection procedures. (Specify: _____)

_____)

Use of Diagnostics

D2. Please check the type of diagnostic procedures that were used in this dwelling to perform the work during the time period identified in Question B2. (CHECK ALL THAT APPLY)

- Blower door testing was used to find leakage areas for sealing
- Blower door testing was used to measure air leakage rates
- Blower door testing was used to determine when to stop work using cost-effectiveness guidelines (not minimum ventilation guidelines)
- Distribution system diagnostics were used to find leakage areas for sealing
- Distribution system diagnostics were used to determine system balancing
- Infrared scanning was used
- Indoor air quality testing was used
- Heating system efficiency testing was used
- A heating system safety inspection was conducted
- Other diagnostic procedures. (Specify: _____)

_____)

Quality Control

D3. Please indicate the type of quality control inspection this house received following the work performed during the time period identified in Question B2. (CHECK ALL THAT APPLY)

- A visual quality control inspection after weatherization for envelope measures
- A quality control inspection after weatherization for envelope measures that used blower door testing as a diagnostic tool
- A quality control inspection after weatherization for envelope measures that used infrared scanning as a diagnostic tool
- A visual quality control inspection after weatherization for heating system measures
- A quality control inspection after weatherization for heating system measures that used diagnostic tools such as combustion efficiency testing
- Other quality control procedures. (Specify: _____)

_____)

Client Education

D4. Please check the types of client education that were provided to this house during the time period identified in Question B2. (CHECK ALL THAT APPLY)

- Literature was mailed or left with client
- In-person client education was provided
- Other (Specify: _____)

_____)

E. COSTS: MATERIALS, LABOR, INSTALLATION OVERHEAD AND PROGRAM MANAGEMENT

Definitions and Instructions

This page and Figure 1 on the following page provide background information for completing questions E1 to E4 on pages 10 to 12. The total cost of a program can be divided into **installation costs** and **program management costs** (Fig.1). Total installation costs include the costs of materials, direct labor and overhead expenses that are directly related to the installation process, such as the costs of vehicles, travel, equipment, insurance, field supervision, and training. When contractors deliver services, these installation overhead expenses are included, along with a profit, in the charges made for a job. When agency crews do the work, some of the installation overhead expenses may not be tracked directly on a per-house basis. As a result, there are separate questions for crew vs. contractor installation costs.

If a job is crew-based, supply the materials costs (Question E1), calculate the direct labor costs (Question E2), and estimate the average per-house cost of installation-related overhead expenses (Question E2). To arrive at the overhead expense estimate, for example, your agency's costs for vehicles, equipment, liability insurance, training, travel time, field supervision and any other installation-related expenses in the 1990 program year (PY) should be summed and then divided by the number of homes weatherized in the 1990 program year. If a job is contractor-based, supply the materials costs (Question E1) and the total installed costs (Question E3). If both crews and contractors worked on a house, complete all three questions (Questions E1, E2, and E3). In completing Questions E1, E2, and E3, costs should be for measures installed in this dwelling during the time period identified in Question B2. (Costs for weatherization work performed at other times will be identified in Section G.)

In addition, both crew-based and contractor-based programs should estimate an average program management cost per house weatherized. The program management cost should be calculated by subtracting the total installation costs (labor + materials + installation-related overhead) for all houses weatherized in PY 1990 from the total agency budget (in PY 1990). The total program management cost should then be divided by the number of houses weatherized (in PY 1990) to produce an average per-house program management cost (Question E4).

We realize that different agencies track costs in different ways. Please just use your best judgement in estimating the average installation-related overhead and the average program management expenses.

Figure 1. Program Cost Categories

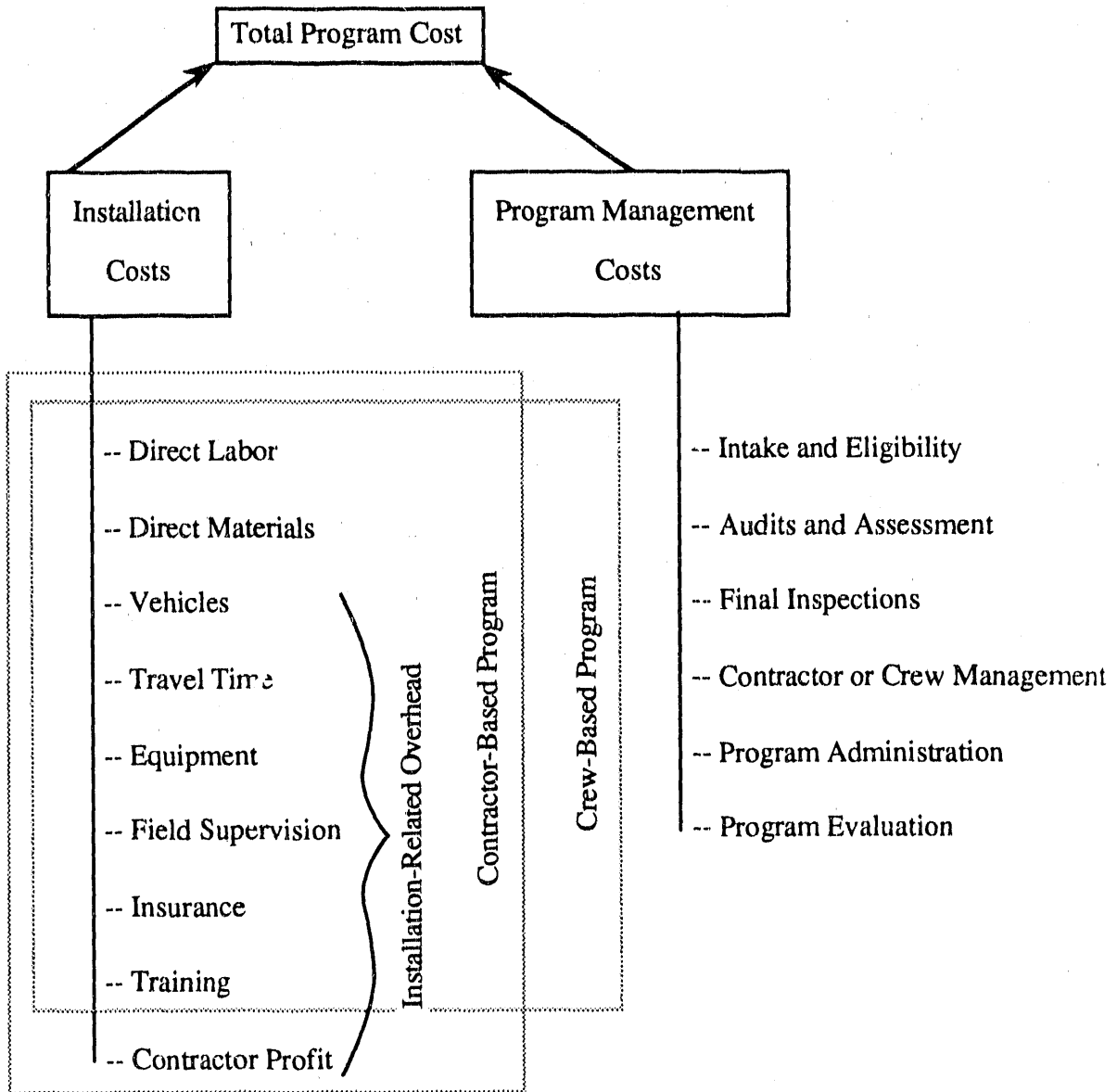

QUESTION E1: BREAKDOWN OF MATERIALS COSTS

In the chart below please fill in the crew-based and/or contractor-based materials cost of the measures that were installed in this dwelling during the time period identified in Question B2. Do not include labor, administrative or program support costs here. Do include costs covered by all sources of funding (i.e., PVE, LIHEAP, or utilities). If you cannot provide the costs by measure, just enter the **TOTAL** materials costs in the box at the bottom.

	Crew-Based Materials Costs	Contractor-Based Materials Costs
Insulation		
attic	\$ _____	\$ _____
wall	\$ _____	\$ _____
other	\$ _____	\$ _____
Air Leakage Control	\$ _____	\$ _____
Water Heating System Measures	\$ _____	\$ _____
Structural Repairs	\$ _____	\$ _____
Windows and Doors	\$ _____	\$ _____
Space Heating System		
retrofit	\$ _____	\$ _____
replacement	\$ _____	\$ _____
Space Cooling System		
retrofit	\$ _____	\$ _____
replacement	\$ _____	\$ _____
Other	\$ _____	\$ _____
	\$ _____	\$ _____
	Crew-Based Total Materials Costs	Contractor-Based Total Materials Costs

QUESTION E2: CREW-BASED INSTALLATION COSTS

Directions: Please fill in the number of crew hours for this house from information in your files for work performed during the time period identified in Question B2. Please fill in your best estimate of the average hourly rate for your crew and multiply this by the number of hours to produce an estimate of the direct labor costs. Estimate the average installation-related overhead by following the directions in the box at the beginning of Section E (page 8).

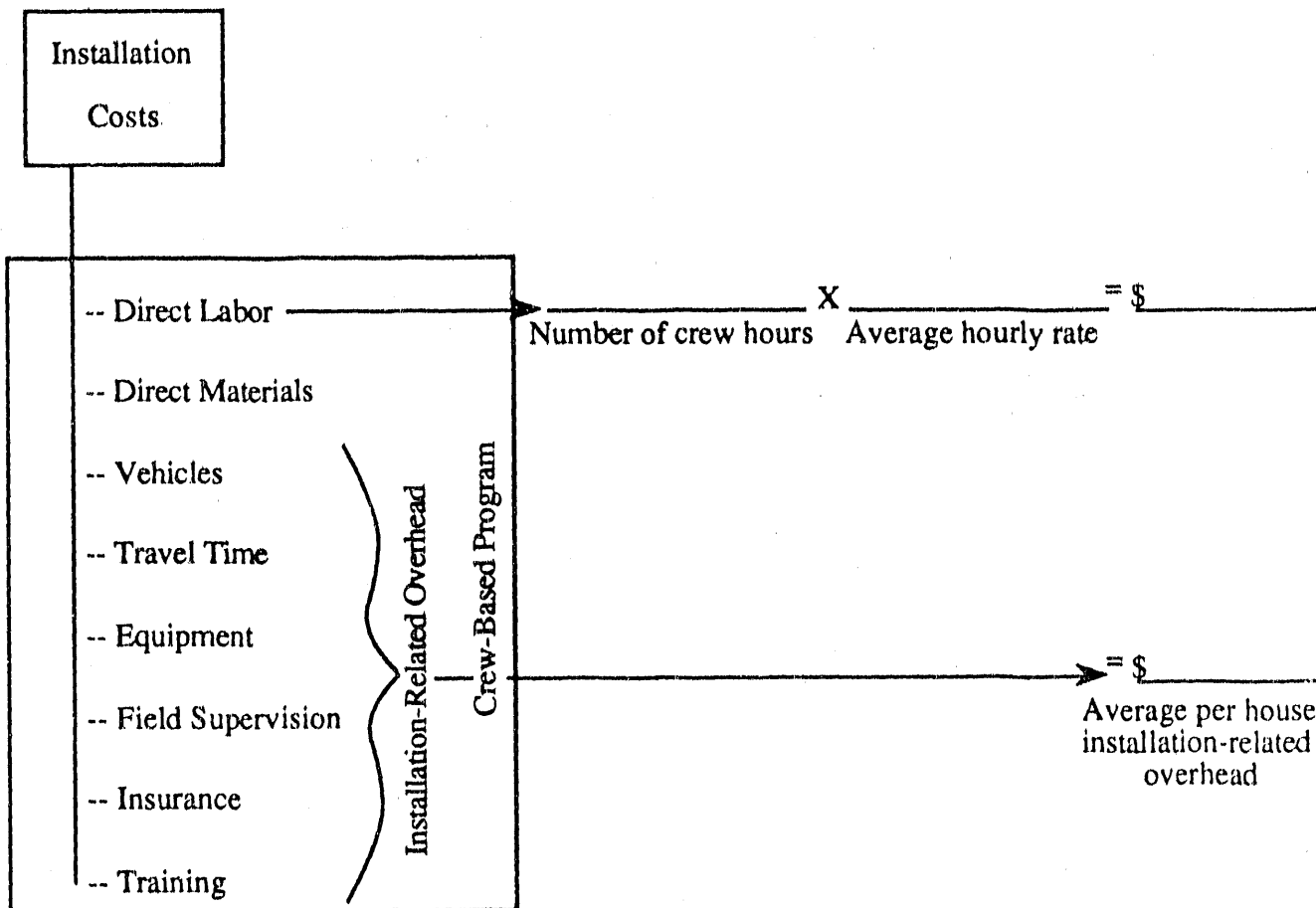

QUESTION E3: CONTRACTOR-BASED INSTALLATION COSTS

Directions: Please fill in the total installation costs billed by contractors for this house for work performed during the time period identified in Question B2. This should include all the cost categories listed above (include the materials costs reported on page 10 in this total, as well as labor costs and installation-related overhead) plus the contractor's profit.

Total Installed Cost \$ _____

QUESTION E4: AVERAGE PROGRAM MANAGEMENT COSTS

Total Program Costs for PY 1990 \$ _____

- Total Installation Costs* for All Houses Weatherized in PY 1990 \$ _____

*Add all direct materials costs, labor costs, and installation-related overhead together to obtain this cost figure.

Total Program Management Costs

→ \$ _____

- Intake and Eligibility
- Audits and Assessment
- Final Inspections
- Contractor or Crew Management
- Program Administration
- Program Evaluation

Average per house** \$ _____
program management cost

**Divide the total program management costs for PY 1990 by the number of houses weatherized in PY 1990.

F. FUNDING SOURCES

F1. What percentage of the funds spent on this house as identified in Section E were funds from DOE's WAP?

_____ %

F2. If funds from non-DOE sources were used, were they all used according to DOE guidelines?

Yes

No

F3. Some program management costs (such as client intake and eligibility checks, or office space and expenses) may be absorbed by other programs or agencies (e.g., LIHEAP, Councils on Aging). What percentage of your program management costs would you estimate are absorbed by other programs or agencies?

_____ %

G. OTHER WEATHERIZATION MEASURES INSTALLED AND THEIR COSTS

G1. Space-heating system measures may have been installed in this dwelling at a different time period than that identified in Question B2 (at the time houses were selected for the study, for example). If so, check any of the measures that were installed. Indicate whether they were installed by in-house crew or contractor.

	Installed by:	
	In-house crew	Contractor
Clean and Tune-up.	[]	[]
Entire Heating System Replacement.	[]	[]
Set-back Thermostat.	[]	[]
Repairs.	[]	[]
(Specify: _____)		
Heating System Component Retrofits.	[]	[]
(Specify: _____)		
Safety Problem Fixed.	[]	[]
(Specify: _____)		
Other Heating System Modifications.	[]	[]
(Specify: _____)		

G2. What were the costs of the measures identified in Question G1 (refer to Section E for directions)?

Material costs:

	crew-based	contractor-based
retrofit	\$ _____	\$ _____
replacement	\$ _____	\$ _____
Total	\$ _____	\$ _____

Crew-based installation costs:

$$\frac{\text{_____}}{\text{Number of crew hours}} \times \frac{\text{_____}}{\text{Average hourly rate}} = \$ \frac{\text{_____}}{\text{Direct labor costs}}$$

Contractor-based installation costs:

Total installation cost: \$ _____

G3. What percent of the funds identified in Question G2 were funds from DOE's WAP?

_____ %

G4. In Question G2 if funds from non-DOE sources were used, were they all used according to DOE guidelines?

- Yes
- No

G5. What were the exact installation dates (month, day, and year) for the measures identified in Question G1?

Installation started on _____

Installation completed on _____

G6. Were any measures other than those identified in Questions C1 - C8 and G1 installed in this dwelling? If so, please describe the measures installed, their costs, the percentage of funds from DOE's WAP, whether the funds were used according to DOE guidelines, and when the installations were performed.

Version: March 20, 1991

Form Completed by: _____
Date: _____

FUEL-OIL STUDY CONTROL HOUSE INFORMATION SURVEY

IDENTIFICATION

House Identifier: (To be completed by ORNL) _____

Subgrantee name: _____

Occupant name: _____

Occupant phone number: _____

Occupant address: _____

GENERAL INFORMATION

What was the household's income on the application form at the time when its eligibility was verified for the weatherization services it will receive in May or June 1991?

\$ _____

What electric utility company serviced this household and what was the household's utility account number?

Electric utility: _____

Account number: _____

WEATHERIZATION MEASURES

The control houses will not be weatherized by your agency until May or June 1991. Nevertheless, your agency may have already installed some measures in this dwelling for various reasons (for safety reasons at the time houses were selected for the study, for example). If any measures were installed, please describe them and identify when the installations were performed.

INTERNAL DISTRIBUTION

- | | |
|----------------------|---------------------------------|
| 1-50. M. P. Ternes | 117. M. A. Kuliasha |
| 51. M. A. Brown | 118. J. M. MacDonald |
| 52. W. P. Levins | 119. H. A. McLain |
| 53. L. G. Berry | 120. W. R. Mixon |
| 54-104. D. P. Bivens | 121-126. R. R. Parks |
| 105. R. A. Cantor | 127. J. H. Reed |
| 106. R. S. Carlsmith | 128. D. E. Reichle |
| 107. C. V. Chester | 129. M. Schweitzer |
| 108. S. M. Cohn | 130. T. R. Sharp |
| 109. G. E. Courville | 131. R. B. Shelton |
| 110. W. Fulkerson | 132. J. N. Stone |
| 111. P. S. Gillis | 133. B. E. Tonn |
| 112. E. A. Hirst | 134. D. L. White |
| 113. R. B. Honea | 135. ORNL Patent Office |
| 114. M. A. Karnitz | 136. Central Research Library |
| 115. C. R. Kerley | 137. Document Reference Section |
| 116. J. O. Kolb | 138-140. Laboratory Records |
| | 141. Laboratory Records - RC |

EXTERNAL DISTRIBUTION

- 142-167. D. A. Beschen, U. S. Department of Energy, 5G-023, CE-532, 1000 Independence Avenue, SW, Washington D. C. 20585
168. Bruce G. Buchanan, Computer Science Department, University of Pittsburgh, 206 Mineral Industries Building, Pittsburgh, Pennsylvania 15260
169. James W. Cooke, DOE, Field Office, Post Office Box 2008, Oak Ridge, TN 37831-6269
170. Richard L. Egli, Assisting Manager, Energy Research and Development, DOE Field Office, Post Office Box 8600, Oak Ridge, TN 37831-8600
171. Allan Hirsch, Vice President, Environmental Sciences and Director, Washington Operations, Midwest Research Institute, 5109 Leesburg Pike, Suite 414, Falls Church, Virginia 22041
172. R. O. Hultgren, Deputy Assistant Manager for Energy Research and Development, DOE Oak Ridge Field Office, P O Box 2001, Oak Ridge, TN 37831-6269
173. Helen M. Ingram, Director, Udall Center for Studies in Public Policy, The University of Arizona, 803/811 East First Street, Tucson, Arizona 85719
174. Calvin D. MacCracken, President, Calmae Manufacturing Corporation, 101 West Sheffield Avenue, P. O. Box 710, Englewood, New Jersey 07631

175. Ralph Nader, Post Office Box 19367, Washington, D.C. 20036
176. Ned Nisson, Energy Design Update, P. O. Box 1709 Ansonia Station, New York NY 10023
177. Jacqueline B. Shrago, Director, Office of Technology Transfer, 405 Kirkland Hall, Vanderbilt University, Nashville, Tennessee 37240
178. Martin Williams, Professor, Department of Economics, Northern Illinois University, DeKalb, Illinois 60115
179. Office of the Assistant Manager for Energy Research and Development, U.S. Dept. of Energy, P. O. Box 2001, Oak Ridge, TN 37831-8600
- 180-189. OSTI, U. S. Department of Energy, Post Office Box 62, Oak Ridge, TN 37831

END

**DATE
FILMED**

5 / 1 / 92

