

A COMPARISON OF ALL-REMOTE AND PERSONNEL ACCESS MAINTENANCE OPERATIONS FOR INTOR\*

P. T. Spampinato  
Fusion Engineering Design Center/Grumman Aerospace Corporation  
Oak Ridge National Laboratory, P.O. Box Y  
Oak Ridge, Tennessee 37831  
(615)576-6476

P. A. Finn and M. Y. Gohar  
Argonne National Laboratory  
Argonne, Illinois 60439

R. R. Stasko  
Ontario Hydro/Canadian Fusion Fuel's Technology  
Project, Ontario, Canada

ABSTRACT

The INTOR reference design was developed to permit limited maintenance operations external to the reactor in a "hands-on" mode; all internal operations would be remotely accomplished. The design embodies those requirements for shielding, tritium containment and cleanup, and confinement of contaminated particulate matter to permit personnel access. The cost reflects these requirements, at least to first order. The impact of personnel access on the reactor design and its cost are cause to reexamine the maintenance approach on which much of the present configuration is based. The purpose of this study is to compare the benefits and costs associated with personnel access maintenance procedures to those associated with all-remote maintenance procedures and to identify modifications to the baseline design that could enhance maintenance operations.

INTRODUCTION

The INTOR activities for 1984-85 included a study of the Critical Issue, Maintainability,<sup>1</sup> in order to compare the benefits and costs associated with personnel access maintenance procedures vs those associated with all-remote maintenance procedures.

The study used the INTOR Phase 2A baseline configuration as the basis for comparison and included: identifying the maintenance requirements common to both approaches and those unique to each; analyzing the biological shield for the all-remote approach; reinvestigating tritium handling requirements; identifying radioactive releases and contamination in the reactor cell; evaluating detailed maintenance scenarios and device downtime; estimating man-rem exposures for the personnel access approach; determining

\*Research sponsored by the Office of Fusion Energy, U.S. Department of Energy, under Contract No. DE-AC05-84OR21400 with Martin Marietta Energy Systems, Inc..

maintenance equipment requirements; and projecting capital and operating costs to first order.

A configuration based on all-remote operations for maintaining both the internal and external reactor components has not been developed. Therefore, to establish a comparison with the reference design, this study included considerations for a configuration that is totally remotely maintainable and investigated the following areas for comparison:

1. Develop the basis for an all-remote configuration.
2. Develop a maintainability study for both designs that identifies remote handling technologies and includes assembly/disassembly procedures.
3. Compare both maintenance approaches by taking into account the important aspects of induced activities and dose rates, waste disposal materials, estimated possible radioactive releases, shield requirements, assembly/disassembly procedures and maintenance-related device downtime, maintenance equipment requirements, tritium containment and control, reactor building and other facility requirements, capital and operational costs, and the flexibility of operations.

ALL-REMOTE CONFIGURATION

In order to understand the potential differences between a design based on personnel access and one based on all-remote operations, it is desirable to have a configuration for the latter approach. Early in this study, it was anticipated that an all-remote design could be developed which was very different from the reference design. This did not turn out to be the case. The reference design inherently embodies features for remote handling because much of the component disassembly must be done remotely as a result of high activation levels within the shield boundary. Also, the reference design has incorporated features to enhance

MASTER

JHP

remote maintenance such as modular component assemblies and access to the torus sectors and the peripheral components. To ensure that additional remote handling enhancements were not overlooked during the development of the reference design, each major system was analyzed with regard to component orientation, location, and quantity. Several secondary modifications were identified, but none that would drastically change the reference design.

The next logical starting point to develop a configuration that does not have personnel access requirements was to establish the minimum shield requirement for the device. This is because a minimum shield suggests minimum cost. This was done on the basis of toroidal field (TF) coil protection considering neutron-induced insulation damage, atomic displacements, and heating. In addition, it was assumed that the INTOR first-wall blanket thickness (50 cm) is 50% effective for the all-remote shield design. The resulting outboard shield thickness was 50 cm compared to 105 cm for the INTOR Baseline. The shield reduction allows the TF coil bore to be reduced by approximately 50 cm and a negligible reduction in poloidal field (PF) coil diameters. The resulting peak-to-average edge ripple for this design is 1.4%, which slightly exceeds the INTOR Baseline requirement of 1.2%.

It was expected that a smaller TF coil cost could be associated with the smaller coil size, but whether this will hinder general remote handling operations is not clear. However, the reduced window opening does require that the divertor module be split into two segments. Clearly, removing split modules with translational as well as radial motion is more difficult and requires handling equipment which is more complex than that for the reference design.

In addition, several other impacts resulted from the reduced outboard shield: the reactor building wall thickness increased by more than 50%, activation in the reactor cell increased by 4 orders-of-magnitude, refrigeration cost for the TF coils doubled, and the TF coil internal coolant design became more complex.

Realizing that the reference design is actually based on reasonable access to components for remote disassembly and that reducing the outboard shield thickness is not a viable approach, the study proceeded on the basis of using the reference design for both approaches. Maintenance assessments were developed using limited personnel access and all-remote operations.

## DESIGN REQUIREMENTS AND ASSUMPTIONS

### Radiological Guidelines and Limits

In order to assess the comparison of personnel access vs all-remote operations, a summary of radiation guidelines and limits was compiled for workers and the general public. Table 1 summarizes this information.

Table 1. Summary of U.S. Policy on Radiation Dose

Operating Conditions	Probability of Occurrence (N/y)	Dose			
		On-Site		Off-Site	
		Guideline	Limit	Guideline	Limit
Normal operation (uncontrolled area)	$p = 1$	$< 0.1$ R/y	$< 0.5$ R/y	$< 10$ mR/y	$< 0.5$ mR/y <sup>a</sup>
Emergency (controlled area)	$10^{-2} < p < 1$	$< 1$ R/y	$< 5$ R/y <sup>b</sup>	$< 100$ mR/y	$< 0.5$ R/y
Infrequent Incidents	$10^{-3} < p < 10^{-1}$	$< 0.1$ R	$< 0.5$	$< 1$ R	$< 0.1$ R
Limiting faults	$10^{-7} < p < 10^{-3}$	$< 0.1$ R	$< 0.5$	$< 0.1$ R	$< 0.1$ R

<sup>a</sup>Per individual.

<sup>b</sup>ppm (1) (Environmental Protection Agency) has proposed a guideline of 10 mrem/y.

The NRC (2) has a limit of 5 mrem/y (whole body).

<sup>c</sup>This is yearly limit, the quarterly limit is 3 Rem.

### Coolant Leakage Source Term

Table 2 is an estimate for INTOR of chronic coolant leakages based on the operating experience of CANDU reactors. Leakage from a system incorporating 1000 components (such as valves, couplings, pumps, etc.) is not expected to exceed 100 gm/d. Specific leakage into the reactor cell should only be a fraction of this, estimated at no greater than 10 gm/d. Leakages of this magnitude are not likely to create a significant hazard with respect to airborne tritium, particularly if the specific activity of tritium in the coolant is not allowed to exceed 1.0 Ci/l. It would further appear that the recirculating atmospheric cleanup system will not have to be in service under normal INTOR operating conditions. Therefore, coolant leakage in the reactor cell is not expected to impact personnel access operations.

Table 2. Estimated Water Leakage from INTOR Coolant Systems

Component helium leak rate cm <sup>3</sup> (STP)/s	Component water leak rate gm/d	Component Inventory = 1000			
		Number of components	Total water leak rate gm/d	Leakage into reactor hall gm/d	Leakage into equipment rooms gm/d
$10^{-6}$	0.01 to 0.06	950	9.5 to 57	0.95 to 5.7	8.5 to 51
$10^{-5}$	0.15 to 0.9	50	7.5 to 45	0.75 to 4.5	6.7 to 40
			Total	1.6 to 10	15 to 91

## DISCLAIMER

This report was prepared as an account of work sponsored by an agency of the United States Government. Neither the United States Government nor any agency thereof, nor any of their employees, makes any warranty, express or implied, or assumes any legal liability or responsibility for the accuracy, completeness, or usefulness of any information, apparatus, product, or process disclosed, or represents that its use would not infringe privately owned rights. Reference herein to any specific commercial product, process, or service by trade name, trademark, manufacturer, or otherwise does not necessarily constitute or imply its endorsement, recommendation, or favoring by the United States Government or any agency thereof. The views and opinions of authors expressed herein do not necessarily state or reflect those of the United States Government or any agency thereof.

### Control of Radioactive Particulates

The control of radioactive particulates is an important consideration for maintenance operations for both the personnel access and the all-remote designs. For the former case, activated particulates may render hands-on operation unacceptable; for the latter case, remote equipment may become unnecessarily contaminated. Therefore, some degree of control is required for both design approaches even though quantifying the requirements can only be estimated at present.

Previous work on the FED design<sup>2</sup> identified the concern for this problem, and estimates of quantities of activated particulates were made in conjunction with torus sector removal. Approximately 200 g of stainless steel dust with a source term of more than 130 ci was assumed to be available to contaminate the reactor cell. Because of this, internal cleaning of the torus in the vicinity of the limiter/divertor was considered to be a requirement prior to removing the limiter/divertor or a torus sector.

At the INTOR Workshop in May 1984, the Impurity Control Group was asked to consider the likelihood of loose particulate matter in the plasma chamber; the group consensus was that such material would be likely in INTOR. This is because fine, loose particles are observed in present tokamak devices. Possible sources of this material are first wall and divertor plate sputtering and disruption erosion. The total amount of material predicted to be eroded is approximately  $3 \times 10^3$  kg/year. However, it is assumed that much of this will redeposit onto the first wall and divertor surfaces, and the amount of material remaining as loose particles is highly uncertain. If the amount remaining is only 0.1% of the total eroded material, then approximately 3 kg/year will accumulate. This estimate is very close to the estimate for the Fusion Engineering Device (FED) since for the ten sectors of that design 2 kg is the total available dust for each sector.

Collecting the particulates in situ before removing device components can minimize the potential for contaminating the reactor cell or maintenance equipment. If this is not sufficient, area decontamination will be required for the personnel access case prior to hands-on operations, and equipment decontamination will be required for the all-remote case after maintenance is completed.

An alternative approach is to remove device components into casks which are attached (sealed) to the outboard shield so that loose particulate matter is contained until the component can be appropriately decontaminated. This procedure implies the use of remotely

operated or automated cask equipment; but, since component removal must be accomplished without personnel for both designs in any event, this type of equipment may not add much additional complexity or downtime. In fact, if casks can be developed with vacuum sealing capability, in addition to the mechanical requirements needed for remote extraction, significant downtime reductions are possible. This is because for this approach the plasma chamber may be kept under vacuum, and the 60 h for detritiation and 168 h for plasma chamber reconditioning may be waived. Figure 1 is a concept for a divertor cask handling device.

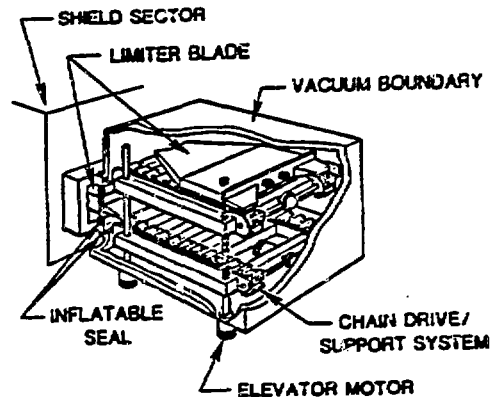

Fig. 2. Concept for a divertor module handling machine.

### TRITIUM HANDLING SYSTEMS

The considerations for tritium handling systems were extensively covered in earlier INTOR studies.<sup>3</sup> In this study, that work was reviewed to ensure that personnel access requirements were met and to determine if requirements could be relaxed for the all-remote maintenance approach. It was determined that the tritium handling requirements applied to both approaches including the need for atmospheric tritium recovery systems, which are determined on the basis of accident conditions and public safety.

For operations in the reactor cell, it was shown that exposures for the personnel access approach are within acceptable limits, and maintenance operations outside the reactor cell are expected to be the same for both approaches. The reactor building for both is based on meeting accident criteria that limit the dose rate at the site boundary to 10 mrem/year. From this it was shown that tritium cleanup requirements are the same for both designs.

## SHIELDING REQUIREMENTS

The INTOR Phase 2A shield was designed to achieve a 2.5 mrem/h dose equivalent in the reactor hall one day after shutdown with all shields in place. This dose level permits a "hands-on" mode of operation to maintain the external reactor components. However, the internal reactor components (divertor, first wall, blanket, etc.) require remotely operated equipment for their maintenance.

In this part of the study, the shield and the reactor building wall thicknesses for three different configurations were investigated. Two configurations permit personnel access one day after shutdown, and the third configuration assumes all-remote maintenance. Two dose equivalent values were considered for the personnel access configurations, 2.5 and 0.5 mrem/h. The 2.5 mrem/h represents the limit for the occupational exposure based on regular operating shifts of 8 h/d during the entire year. The 0.5 mrem/h satisfies the ALARA and Department of Energy (DOE) design guideline for occupational exposure.

The remote configuration design is based on providing adequate protection for the TF coils without any consideration for the dose equivalent in the reactor cell. For each configuration, the thickness of the reactor building wall was designed to attenuate the dose equivalent to 0.05 mrem/h during operation.

It was determined that there is no advantage to be gained by reducing the outboard device shield because of other impacts. Activation in the reactor cell increased by  $10^4$ , the reactor building wall thickness increased by 50%, and heating to the TF coils doubled the refrigeration cost. Hence, the all-remote approach assumed the same shield requirements as the reference configuration.

## ASSESSMENT OF MAINTENANCE SCENARIOS

Maintenance scenarios representative of scheduled and unscheduled operations were selected to assess device downtime and to estimate personnel exposure levels. Each scenario was developed using limited personnel access for one approach and no personnel access for the other approach. The following replacement scenarios were considered: divertor modules, rf heating module, test module, cryopump module, torus sector, and TF coil.

The 12 divertor modules are assumed to require annual replacement. This scenario was developed in detail for the replacement of a single module and then scaled up to 12 modules, assuming that operations proceed simultaneously on pairs of modules. The greatest impact on downtime is plasma chamber detritiation and reconditioning, which accounts for 40%.

Lower hybrid resonance heating (LHRH) was assumed for the rf heating module replacement because of coax feed lines. Clearly, this assessment points out the need to modify the design of this module to minimize the complexity of disassembling and reassembling approximately 200 coax joints. Approximately 60% of the downtime is caused by detritiation and reconditioning.

Two test module installations are possible: one that is behind the vacuum boundary of the plasma chamber and an other in front of the vacuum boundary. Removal for the first case does not require detritiation and reconditioning; therefore, device downtime is minimal. The second case was analyzed because it has the greatest impact on downtime and is required for certain test modules that must view the plasma directly. For this case, detritiation and reconditioning accounts for 70% of the device downtime.

Replacement of any cryopump module is the only scenario considered that does not require venting the plasma chamber. This is because the pumps are behind vacuum isolation valves. In addition, for the personnel access approach, this is the only scenario that does not require any remote operations.

Removal of the torus sector is required for blanket maintenance operations in the hot cell. Strictly speaking, the torus is designed as a lifetime component. For this scenario, the sector that interfaces with the ion cyclotron resonance heating (ICRH) module is considered and connections to that sector for the ICRH system and the divertor module are disassembled, but these modules remain installed in the sector. Approximately 70% of the downtime results from detritiation and reconditioning.

The TF coil replacement is a major unscheduled occurrence. The scenario for this operation includes thermally cycling all of the coils within the common cryostat, removal of two torus sectors, and removal of the upper PF coils. Reinstalling the new coil and reassembling the device is assumed to take 50% longer than the initial disassembly. This is the only scenario that requires warming the coil system; all others are accomplished with the coils kept at cryogenic temperature.

A summary of the maintenance comparisons is shown in Table 3 for both approaches. Tables 4 and 5 are representative of the analysis for all maintenance scenarios.

### Lifetime Maintenance Estimates

The maintenance scenarios analyzed were single occurrences during the device lifetime, such as removing and replacing divertors or a torus sector; also, the comparisons between

Table 3. Summary of maintenance comparisons

Task	Personnel Access Design	All-remote Design
<b>1. Divertor Module Replacement</b>		
1 Module: Total Downtime	290 h	290 h
Total Man-Hours	64	--
Total Exposure	9.2 M-R	--
12 Modules: Total Downtime	372 h	356 h
(6 pairs) Total Man-Hours	582	--
Total Exposure	1.5 M-R	--
<b>2. LHRH Module Replacement</b>		
Total Downtime	324 h	413 h
Total Man-Hours	158	--
Total Exposure	0.4 M-R	--
<b>3. Test Module Replacement</b>		
Total Downtime	305 h	323 h
Total Man-Hours	34	--
Total Exposure	0.1 M-R	--
<b>4. Cryopump Replacement</b>		
Total Downtime	47 h	42 h
Total Man-Hours	47 h	--
Total Exposure	0.1 M-R	--
<b>5. Torus Sector Replacement</b>		
Total Downtime	355 h	378 h
Total Man-Hours	264	--
Total Exposure	0.7 M-R	--
<b>6. TF Coil Replacement</b>		
Total Downtime	144 d	198 d
Total Man-Hours	10,900 h	--
Total Exposure	152 M-R	--

Table 4. Divertor module replacement with personnel access

Steps	Mode of operation	Personnel	Duration (hrs)
1a. General device shutdown	A		1
b. De-energize coils	A		3
c. Drain systems of coolant	A		60
d. Torus helium cycle	A		60
<hr/>			
2a. Radiation survey of entire divertor*	C	4	6
b. Measurement coolant lines	C	2	6
c. Install extraction device on module	C	2	4
d. Extract module	B		2
e. Lift and move module to hot cell transfer tunnel	B		2
<hr/>			
3a. Position replacement module onto extraction device	B		4
b. Install module into sector	B		4
c. Inspect module alignment and vacuum extractor	B		2
d. Radiation survey, done as required	B		6
e. Inspect bolt alignment of flanges and coil interface	C	2	2
f. Install flange attachments and coolant lines	C	2	4
g. Purge plasma chamber with helium and test module flange; leak test coolant lines	C	2	4
<hr/>			
4a. Recondition plasma chamber for startup	A		150
<hr/>			
Total time after shutdown			290 h (12.1 days)
Total manhours to cell			64
Total man-rem exposure			64 x 2.5 = 160 (1.75 man-rem)

\*This may be accomplished remotely.

both design approaches were for single occurrences. Expanding these estimates over the device lifetime along with additional downtime to account for the multitude of secondary scheduled and unscheduled events allows a total downtime to be developed that can be averaged over the device lifetime. From

Table 5. Divertor module replacement: All remote

Steps	Mode of operation	Duration (hrs)
1a. General device shutdown	A	1
b. De-energize coils	A	3
c. Drain systems of coolant	A	60
d. Torus helium cycle	A	60
<hr/>		
2a. Measurement coolant lines and extract device attachments	B	13
b. Install extraction device on module	B	7
c. Extract module	B	2
d. Lift and move module to hot cell transfer tunnel	B	2
<hr/>		
3a. Position replacement module onto extraction device	B	4
b. Install module into sector	B	4
c. Inspect module alignment and vacuum extractor	B	2
d. Inspect bolt alignment of flanges and coil interface	B	4
e. Install flange attachments and coolant lines	B	12
f. Purge plasma chamber with helium and test module flange; leak test coolant lines	B	7
<hr/>		
4a. Recondition plasma chamber for startup	A	150
<hr/>		
Total time after shutdown		290 (12.1 days)

this, an easier comparison can be made between designs, and the average annual exposure can be estimated for the personnel access case. This approach oversimplifies lifetime maintenance analysis but permits a first approximation of the device availability. This estimate considered only maintenance activities in the reactor cell.

Assuming 10 years of deuterium-tritium (D-T) operation, the following extrapolations were derived for lifetime maintenance for both scheduled and unscheduled operations for the replacements listed below:

1. Biannual scheduled replacement of windows for the heating systems using the LHRH as the basis - four lifetime replacements.
2. Biannual replacement of cryopumps, test modules, and other small peripheral equipment - four lifetime replacements.
3. Annual replacement of divertor modules - nine lifetime replacements.
4. A single replacement of each blanket and first wall (i.e., a torus sector replacement) - twelve lifetime replacements.
5. One TF coil replacement; one lifetime replacement.
6. One PF coil replacement (derived from the TF coil replacement scenario) - one lifetime replacement.

Table 6 summarizes the maintenance parameters for downtime, personnel requirements, and exposure to personnel for both design approaches. Dividing these totals by ten gives an average annual value. Some interesting conclusions may be drawn from this table, keeping in mind that this type of analysis represents a very superficial approach to lifetime maintenance operations.

Table 6. Summary of lifetime maintenance operations over ten years of D-T operations

Replacement	Lifetime occurrence	Personnel Access			All-Remote
		P-T	R-S	R-a	R-T
Divertor	8	4700	5300	15.5	5000
Cryopump (12 pairs) = 10 <sup>4</sup>	4	23000	15000	37.5	20100
Heating = 4	4	5200	2500	6.5	6600
Turns counter = 12	1	4000	2300	5.0	4000
TF coil	1	3500	10000	152.0	4700
PF coil	1	1500	4300	15.5	1600
		41600	42100	233.0	42000
Total lifetime downtime (for personnel access)		41,500 h			
Total lifetime downtime (for all-remote)		42,000 h			
Total lifetime personnel requirement		43,100 Man-Hours			
Total lifetime personnel exposure		233 Man-Rems			

\*The factor of 10 is used to account for additional lifetime downtime for the multitude of secondary scheduled and unscheduled events.

#### Comparison of Downtime and Exposure

A comparison of total downtime for the two designs indicates very little difference in the personnel access and all-remote operations. This is partially explained by the facts that personnel access to the device is limited and that much of the maintenance and disassembly must be accomplished remotely. The average annual downtime for the personnel access case is 4,150 h and for the all-remote case, 4,200 h. This means that, on average, the device will have approximately 20 less days of downtime for the personnel access case. This difference is not significant because the average annual downtime is, at best, a first-order approximation. Therefore, the conclusion is that either design approach has essentially the same impact on device downtime.

If personnel exposure is a critical issue for maintenance activities, then the all-remote case may be advantageous. From Table 6, the total personnel exposure is 233 man-rem for the device lifetime or approximately 25 man-rem per year for reactor cell operations. This indicates that 25 mechanics may spend up to 400 h/year at the device shield boundary if the dose level is 2.5 mrem/h or 2000 h/year if the dose level is 0.5 mrem/h. These numbers are based on limiting personnel exposure to <math>\leq 1</math> rem/year. An annual exposure level of 25 man-rem in the reactor cell is quite low, particularly compared to fission plant experience. Hence, personnel access is an acceptable approach which does not impose excessive dose levels.

#### CONCLUSIONS

A configuration based on all-remote operations that allows limited personnel access is the most effective design for maintenance. This approach provides for flexibility of operations and the reduction of operating risks inherent in next-generation devices. The results of the study, which are summarized below, support this conclusion.

#### Results

1. Significant cost differences were not identified; maintenance equipment costs for the all-remote approach are 10% higher (~\$7 M) but operating costs are the same.
2. Device shielding for the all-remote approach could be reduced by 50 cm; however, the reactor building wall thickness increases by 50%, activation in the reactor cell increases by  $10^4$ , and TF coil nuclear heating is higher.
3. Requirements for tritium handling are the same for both approaches and are determined by accident conditions and safety to the general public.
4. No significant differences were identified between maintenance scenarios for the two approaches; the personnel access approach still requires much of the maintenance to be done remotely, device downtime averaged 15% less for the personnel access approach, and annual personnel exposures for reactor cell operations were low (25 man-rem).

#### ACKNOWLEDGMENT

The authors wish to acknowledge the valuable contributions of the other INTOR participants to the "Maintainability" Critical Issue: F. Farfaletti-Casali and M. Chazalon (EC); K. Tomabechi and T. Honda (Japan); B. Kolbasov and G. Shatalov (USSR).

#### REFERENCES

1. P. T. Spampinato et al., INTOR Critical Issue D: Maintainability, ETR/INTOR/CDF/6, Fusion Engineering Design Center, ORNL (to be issued as Chapter VI of the 1985 U.S. INTOR Report).
2. P. H. Sager et al., FED Baseline Engineering Studies Report, ORNL/FEDC-82/2, Chapter 10, Oak Ridge National Laboratory, April 1983.
3. W. M. Stacey, Jr., et al., U.S. FED-INTOR Critical Issues, Vol. II, Chapter VIII, USA FED-INTOR/82-1, October 1982.