

2

RECEIVED BY DSTI JUN 11 1985

UCRL- 92092
PREPRINT Rev. 1

CONF-850310-113-Rev. 1

Multivariable Current Control
For Electrically And Magnetically Coupled
Superconducting Magnets*

Earle W. Owen
Daniel W. Shimer

Sixth Topical Meeting On The
Technology Of Fusion Energy
Sheraton-Palace, San Francisco, California
March 3-7, 1985

February 8, 1985



This is a preprint of a paper intended for publication in a journal or proceedings. Since changes may be made before publication, this preprint is made available with the understanding that it will not be cited or reproduced without the permission of the author.

Unclassified

DISCLAIMER

This report was prepared as an account of work sponsored by an agency of the United States Government. Neither the United States Government nor any agency thereof, nor any of their employees, makes any warranty, express or implied, or assumes any legal liability or responsibility for the accuracy, completeness, or usefulness of any information, apparatus, product, or process disclosed, or represents that its use would not infringe privately owned rights. Reference herein to any specific commercial product, process, or service by trade name, trademark, manufacturer, or otherwise does not necessarily constitute or imply its endorsement, recommendation, or favoring by the United States Government or any agency thereof. The views and opinions of authors expressed herein do not necessarily state or reflect those of the United States Government or any agency thereof.

UCRL--92092-Rev.1

DE85 012943

MULTIVARIABLE CURRENT CONTROL FOR ELECTRICALLY AND MAGNETICALLY COUPLED SUPERCONDUCTING MAGNETS*

Earle W. Owen and Daniel W. Shimer, Lawrence Livermore National Laboratory
P.O. Box 808
Livermore, CA 94550
(415)422-1393

ABSTRACT

Superconducting magnet systems under construction and projected for the future contain magnets that are magnetically coupled and electrically connected with shared power supplies. A change in one power supply voltage affects all of the magnet currents. A current controller for these systems must be designed as a multivariable system. The paper describes a method, based on decoupling control, for the rational design of these systems. Dynamic decoupling is achieved by cross-feedback of the measured currents. A network of gains at the input decouples the system statically and eliminates the steady-state error. Errors are then due to component variations. The method has been applied to the magnet system of the MFTF-B, at the Lawrence Livermore National Laboratory.

*Work performed under the auspices of the U. S. Department of Energy by the Lawrence Livermore National Laboratory under contract number W-7405-ENG-48.

INTRODUCTION

In the past the design of current control systems for superconducting magnets has focused on single isolated coils.¹ The construction of complex systems of superconducting magnets, connected together electrically and coupled magnetically, brings new control problems. An interconnected system cannot always be separated into isolated control systems. In general the magnets must be treated as a multivariable system. In a multivariable system a change in one of the inputs affects all of the outputs and a transient disturbance is felt throughout the system.

The MFTF-B magnet system,² to which the method described in this paper has been applied, is a good example of fusion magnet systems of the future. There are 42 superconducting magnets, all coupled to a greater or lesser extent magnetically. Eight of the magnets are connected electrically in pairs with a common main power supply and a trim power supply. This configuration is used as an example in this paper. Twelve of the magnets are connected together with a main supply and several

trim supplies.³ The remaining coils, although linked magnetically to the others, have their own supplies.

It was found that the coils with their own supplies can be designed as separate, single variable systems. However, when the magnets are connected together with common power supplies, the electrical coupling cannot be ignored and the current control must be designed for the connected coils as a multivariable system.

A brief description of the coils and the system requirements will indicate the scope of applications covered by this paper. The multivariable magnets have inductances below 10 H, cable resistances in the milliohm range or below, and magnetic coupling coefficients to the nearest magnet that can be as high as .8. The power supplies are unfiltered thyristor devices, necessitating a filter in the current feedback path. Each supply has its own voltage control feedback loop, the current control is superimposed on this control system.

The current must be set to an accuracy of 0.25%, a requirement that puts a bound on the error in the current controller. The dynamic response is fixed by a settling time requirement. The current must settle to one part in 40,000 in five minutes.

Multivariable control is a well developed branch of automatic control theory. An introduction to the methods can be found in the book by Brogan⁴ while Wonham has written an advanced text.⁵ The method in this paper is derived from work on decoupling control, a subset of multivariable control theory. Decoupling control was first described by Falb and Wolovich,⁶ A definitive summary is due to Morse and Wonham.⁷

As has been mentioned, in a multivariable system the inputs and outputs are so coupled that each input affects all of the outputs. The dependence of each output in all of the inputs may apply to the dc steady state as well as to the dynamic behavior. A decoupling controller simplifies the control of the system so that each input affects only a corresponding output. Dynamic decoupling is accomplished by means of feedback networks that

MASTER
DISTRIBUTION OF THIS DOCUMENT IS UNLIMITED

cause each error signal to depend on all of the measured outputs. Static decoupling can be achieved by a network of gains that form a modified reference input from all of the reference inputs.

This paper takes a known theory, multivariable control theory, and applies it to a new application, the control of current in magnetically and electrically coupled superconducting coils. However, the application is not entirely straightforward. Decoupling control is only possible for a simplified system. A procedure is outlined for designing the controller, based on a simplified system and then testing the design on a representation closer to the actual system. In addition, it is shown how the steady state error can be eliminated by the same network that statically decouples the system. The remaining error, which is due to changes in the system components, is calculated as part of the design procedure.

The design procedure outlined provides a systematic method of designing the control system. The resultant design is easy to implement, either by analog circuits or in a digital controller.

THE COIL NETWORK

The MFTF-B coils connected in pairs with a main power supply and a trim are used as an example. However, the method is applicable to other configurations and is used, in fact, in the design of the 12 electrically connected MFTF-B magnets.

The network is shown in Figure 1. The two coils in the center share a main and a trim power supply, the voltage v_2 represents the main supply, v_3 the trim supply. Two separate coils not connected electrically but coupled magnetically are shown. These coils represent the most closely coupled adjacent magnets. The circuit model includes the cable resistances R_{m1} , R_{m2} , and R_t and the dump resistors R_{d1} and R_{d2} .

A state equation,⁸ with the coil currents as the state variables is conveniently derived by defining loop currents as shown in the figure. Following the paths traced out by the coil currents yields the following matrix voltage law equation

$$L \frac{di}{dt} + R(i + i_d) + Wv = 0,$$

where L , R , and W are 5 by 5 square matrices as defined in the Appendix and i , i_d , and v are the current and voltage vectors.

Applying the voltage law to the loop around the coils and the dump resistors yields

$$L \frac{di}{dt} = R_d i_d$$

or

$$i_d = R_d^{-1} L \frac{di}{dt}$$

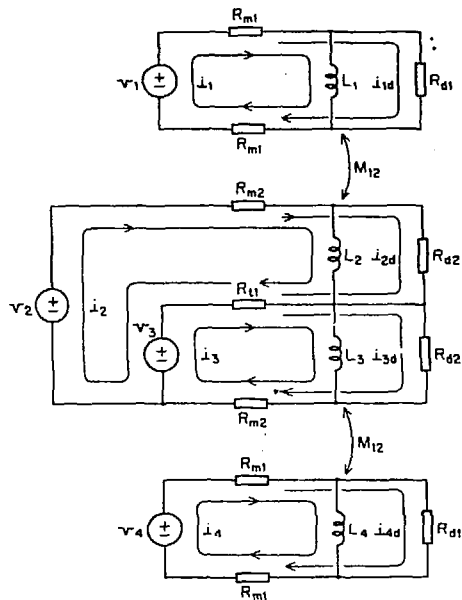

Figure 1. Two electrically connected coils sharing the same power supplies and two adjacent magnetically coupled coils.

Substituting this result into the previous equation leads to the state equation of the network

$$\frac{di}{dt} = -(L + R R_d^{-1} L)^{-1} R i - (L + R R_d^{-1} L)^{-1} W v$$

$$= A_n i + B_n v.$$

THE CLOSED LOOP SYSTEM

The closed loop current control system is shown in Figure 2. The coil current, which is the output, is converted into a voltage by a current shunt and amplifier. A filter then removes some of the power supply ripple. The remainder of the feedback path consists of a network of gains that allow crossfeedback. In the forward path are gain elements, the voltage regulated power supplies, and the network itself. G_r is an open-loop error compensator and static decoupler.

Three parts of the closed loop system, the network, the filters, and the voltage regulators contain energy storage elements, the remaining elements are simple gains. The energy storage elements are represented by state variable equations. In all, there are 15 state variables, five coil currents i , five filter voltages v_f , and five power supply voltages v .

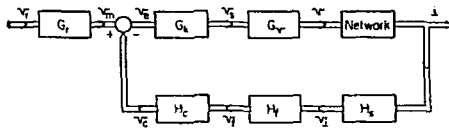

Figure 2. A block diagram of the closed loop current control system.

The state equation for the network has already been written. A first order representation is used for the filters

$$\frac{dv_f}{dt} = -H_f v_f + H_f v_i$$

where H_f is a 5 by 5 diagonal matrix which, like the other matrices in this section is written out in full in the Appendix.

The voltage regulators are represented by their most significant poles

$$\frac{dv}{dt} = -G_v v + G_v v_s$$

where G_v is a 5 by 5 diagonal matrix.

The dynamic elements are linked by the non-dynamic gains

$$v_c = H_c v_f$$

$$v_s = G_k v$$

$$v_m = G_r v_r$$

and $v_i = H_s i$.

From the connections shown in Figure 2

$$v_s = G_k G_r v_r - G_k H_c v_f$$

Using these last several equations the state equations are written in terms of the state variables only

$$\frac{dv_f}{dt} = -H_f v_f + H_f H_s i$$

$$\frac{dv}{dt} = -G_v v - G_v G_k H_c v_f + G_v G_k G_r v_r$$

These last two equations and the network equation are assembled to form the state equation of the closed loop system. It is written below in partitioned form

$$\begin{bmatrix} \frac{di}{dt} \\ \frac{dv_f}{dt} \\ \frac{dv}{dt} \end{bmatrix} = \begin{bmatrix} A_n & 0 & B_n \\ H_f H_s & -H_f & 0 \\ 0 & -G_v G_k H_c & -G_v \end{bmatrix} \begin{bmatrix} i \\ v_f \\ v \end{bmatrix} + \begin{bmatrix} 0 \\ 0 \\ G_v G_k G_r \end{bmatrix} v_r$$

$$\text{or } \frac{dx}{dt} = A x + B v_r \quad (1)$$

And finally, it should be noted that the coil currents are the output of the system

$$\text{output} = i$$

THE STEADY STATE ERROR

The accuracy to which the current can be set in the dc steady state, after the transients have died away, is one of the system requirements. An important contributor to the error is the steady state error of the closed loop system. All closed loop systems without an integrator in the loop have a steady state error for a constant input. A difference between the output and the reference input is required in order to maintain the control effort.

The steady state error can be derived from the state equation by setting the derivatives to zero. In the dc steady state all the transients have died away and the state variables are constant. For the network state equations

$$Ri + Wv = 0$$

Upper case letters are used to denote the dc steady state values of the variables.

The filters and voltage regulators become unity gains, causing the closed loop system to degenerate into the block diagram shown in Figure 3. From this figure,

$$v = G_k (G_r v_r - H_c v_f)$$

Substituting in the network equation and rearranging yields

$$i = (G_k H_c H_s - W^{-1} R)^{-1} G_k G_r v_r \quad (2)$$

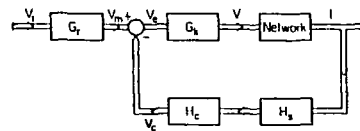

Figure 3. A block diagram of the closed loop system for the dc steady state. This diagram also represents the simplified system.

In general this expression is not amenable to algebraic analysis. However, for the network shown in Figure 1, the mutual coupling between the electrically connected coils and the other two coils is zero in the dc steady state. Therefore, the above equation degenerates into three uncoupled equations, a coupled pair for the connected coils and two single equations for the isolated coils.

For the coupled coils the steady state error in the two currents is interdependent. That is, the error in one of the currents depends not only on the setting of that current but on the other current as well. Algebraic and numerical investigation shows that the error caused by I_3 on I_2 has the opposite sense to the error caused by I_2 on I_3 . The magnitudes of the errors depend on a ratio of the cable resistances and gains and are not in general equal. But, as is the case in single variable systems, the steady state error is reduced by increasing the gain.

The steady state error can be thought of as a calibration error that can be removed by adjusting the calibration. The adjustment is made by changing the value of the reference input by means of a gain. This is one of the functions of G_r , the open loop gain element at the input. The other function of G_r is to decouple the currents statically. Without G_r a change in one reference input affects both dc currents. G_r causes each of the inputs to affect only one current.

The desired dc steady state relationship between the reference input and the current is

$$I = DV_r$$

$$\text{where } D = \begin{bmatrix} \frac{1}{h_s} & 0 \\ 0 & \frac{1}{h_s} \end{bmatrix}$$

The value of G_r that decouples the static system and eliminates the steady-state error is found by comparing this equation with the equation for the steady state closed loop behavior, Equation 2. To achieve the goal let

$$D = (C_k H_C H_S - W^{-1} R)^{-1} G_k G_r$$

This equation can be solved for G_r ,

$$G_r = (H_C H_S - C_k^{-1} W^{-1} R)^{-1} D \quad (3)$$

G_r perfectly eliminates the error only if the system values used to calculate G_r are exactly the same as the actual values. If the values are not known exactly, or if they change, there is an error. The main contributors to this error are the cable resistances, which depend on temperature. The error can be calculated if the temperature range of the cables is known. Like the classic steady state error, this error is reduced by increasing the loop gain.

DYNAMIC DECOUPLING

Although G_r decouples the steady state currents the system remains coupled dynamically. That is, a change in one of the reference inputs causes a transient in all of the currents.

In addition, without a systematic method the design of a multivariable feedback system is difficult. Decoupling control provides such a technique.

It is neither possible, nor necessary to decouple all of the system modes. The dynamic behavior of the system is dominated by the natural frequencies of the coil network. The time constants of the circuit are orders of magnitude slower than the time constants of the voltage regulators and the filters. Furthermore, only the coil network contributes to the dynamic coupling of the system. Therefore, it is reasonable to base the control system design on the circuit alone.

Replacing the filters and the voltage regulators by unity gain reduces the block diagram to that shown in Figure 3. There is only one state variable, the coil current, which is also the output.

The state equation is

$$\frac{di}{dt} = A_n i + B_n v$$

$$\text{and } v = C_k(G_r v_r - H_C H_S i)$$

From these two equations the state equation of the simplified closed loop system is written.

$$\begin{aligned} \frac{di}{dt} &= (A_n - B_n C_k H_C H_S) i + B_n C_k G_r v_r \\ &= A_s i + B_s v_r \end{aligned}$$

The simplified equation has a nonsingular B_s matrix that is amenable to the design of a decoupling feedback system. Dynamic decoupling is obtained if

$$P = A_n - B_n C_k H_C H_S$$

where P is a diagonal matrix with the diagonal elements equal to the desired poles of the closed loop system. The feedback gains that decouple the system and cause the system to have the desired poles are obtained by solving for H_C

$$H_C = G_k^{-1} B_n^{-1} (A_n - P) H_S^{-1} \quad (4)$$

In general the equation is intractable to algebraic solution and H_C must be evaluated numerically.

THE DESIGN PROCEDURE

The design procedure can be summarized briefly. The desired closed loop poles are chosen, and using the simplified system H_C , the feedback matrix and then G_r the input decoupling matrix are calculated.

The designs are tested by calculating the closed loop poles and error of the full scale system when this system contains the calculated values of G_r and H_c .

The poles are chosen from a range extending from the dominant open loop poles to poles two or three orders of magnitude faster. If all of the coils have the same required dynamic response, the desired poles, for each design, are equal.

The dynamic decoupling matrix H_c is calculated for the simplified system from Equation 4. In making this calculation the gains G_k can be set at a nominal value. The product $G_k H_c$ determines the loop gain, consequently the contribution of each factor can be arbitrarily assigned.

After H_c has been calculated G_r can be calculated from Equation 3.

Each design resulting from a choice of P is evaluated by calculating the dynamic response and error of the full scale system containing the voltage regulators and the filters. The poles of the full scale closed loop system are found by substituting the calculated values of H_c in the A matrix of Equation 1, and finding its characteristic values.

The steady state error caused by changes in the system parameters is calculated from Equation 2, the equation relating the steady state current to the reference inputs. The value of G_r , calculated using nominal values of the system parameters is used in this equation. If the same values are used in the remaining matrices of Equation 2, the steady state error is zero. The error due to component changes is investigated by using the range of parameter values in the other matrices while holding G_r at the nominal value. In general, one component dominates the error, consequently the calculations can be confined to the range of this component.

The calculations can be made by means of a digital computer. In our work, the entire design procedure is combined in a single program, with the desired poles, system components, and variation of the components as the input and the closed loop poles and error of the full scale system as the output.

A final step in the design procedure is to simulate the network and closed loop control system using a computer network and system simulation code. Simulation provides an independent check on the design, and allows the inclusion of nonlinear or other properties not encompassed by the design method. The designer can also view the system's time behavior and test operating modes before the system is built.

THE RESULTS

The first step in the design procedure, choosing the desired poles of the closed loop system, indirectly specifies the loop gain. As the speed of the desired poles increases, the values of H_c increase, increasing the loop gain.

The decoupling feedback gains H_c are calculated for a simplified system and then tested in the full scale system that more closely resembles the actual system. When the desired poles are slow the poles of both systems are similar. As the desired poles are speeded up, but are still overdamped, the poles of the full scale system become oscillatory and finally unstable. However, and this is an important point, the poles of the full scale system remain grouped together.

At low gains the dynamics of the voltage regulator and filter, which are not accounted for in the simplified system, are dominated by the network poles. At high gains the slowest of these poles contribute to the response.

The decoupled designs were compared with systems without crossfeedback gains designed by trial and error methods. All of the designs studied had a dominant closed loop pole and other lesser poles as contrasted with the grouped poles of the decoupled design. The result is that for a given dynamic response, as measured by the dominant pole, a high gain, and lesser error, can be achieved using decoupling feedback.

CONCLUSIONS

A method of designing the current control systems for magnetically coupled and electrically connected superconducting magnets has been presented. The method, based on a simplified decoupling control, rationalizes the design procedure and produces a superior system. The controller, which consists of gain elements is easily implemented. Using the method it has been possible to meet the design requirements of the MFTF-B magnets.

REFERENCES

1. Y. MURAKAMI et al., "Control System of Thyristor Power Converter for Superconducting Magnets," *Electrical Engineering in Japan*, Vol. 98, No. 3, 43-50 (1978).
2. S.T. WANG et al., "The MFTF-B Superconducting Magnet System," *Proc. 9th Int. Cryogenic Engineering Conf.*, Kobe, Japan (May 11-15, 1982).
3. E. W. OWEN, D. W. SHIMER, and S. T. WANG, "Alternative Power Supply and Dump Resistor Connections for Similar, Mutually Coupled, Superconducting Coils", *Proc. of the 10th Symp. on Fusion Engineering*, Philadelphia, (Dec. 5-9, 1983).
4. W. L. BROGAN, *Modern Control Theory*, Quantum Publishers, New York (1974).
5. W. M. WONHAM, *Linear Multivariable Control. A Geometric Approach*, Springer-Verlag, New York (1979).

6. P. L. FALB and W. A. WOLQVICH, "Decoupling in the Design and Synthesis of Multivariable Control Systems," IEEE Trans. on Automatic Control, Vol AC-12, No. 6, 651-659 (Dec. 1967).

7. A. S. MORSE and W. M. WONHAM, "Status of Noninteracting Control," IEEE Trans. on Automatic Control, Vol AC-16, No. 6 568-581, (Dec. 1971).

B. M. ATHANS et al., Systems, Networks and Computation; Multivariable Methods, McGraw Hill, New York (1974).

APPENDIX

$$L = \begin{vmatrix} L_1 & M_{12} & 0 & 0 \\ M_{12} & L_2 & 0 & 0 \\ 0 & 0 & L_2 & M_{12} \\ 0 & 0 & M_{12} & L_1 \end{vmatrix}$$

$$R = \begin{vmatrix} 2R_m & 0 & 0 & 0 \\ 0 & R_{m2} + R_t & -R_t & 0 \\ 0 & -R_t & R_{m2} + R_t & 0 \\ 0 & 0 & 0 & 2R_{m1} \end{vmatrix}$$

$$W = \begin{vmatrix} -1 & 0 & 0 & 0 \\ 0 & -1 & 1 & 0 \\ 0 & 0 & -1 & 0 \\ 0 & 0 & 0 & -1 \end{vmatrix}$$

$$D = \begin{vmatrix} R_{d1} & 0 & 0 & 0 \\ 0 & R_{d2} & 0 & 0 \\ 0 & 0 & R_{d2} & 0 \\ 0 & 0 & 0 & R_{d1} \end{vmatrix}$$

$$H_F = \begin{vmatrix} S_f & 0 & 0 & 0 \\ 0 & S_f & 0 & 0 \\ 0 & 0 & S_f & 0 \\ 0 & 0 & 0 & S_f \end{vmatrix}$$

$$G_v = \begin{vmatrix} S_v & 0 & 0 & 0 \\ 0 & S_v & 0 & 0 \\ 0 & 0 & S_v & 0 \\ 0 & 0 & 0 & S_v \end{vmatrix}$$

$$H_c = \begin{vmatrix} h_{c11} & h_{c12} & h_{c13} & h_{c14} \\ h_{c21} & h_{c22} & h_{c23} & h_{c24} \\ h_{c31} & h_{c32} & h_{c33} & h_{c34} \\ h_{c41} & h_{c42} & h_{c43} & h_{c44} \end{vmatrix}$$

$$C_k = \begin{vmatrix} g_{k1} & 0 & 0 & 0 \\ 0 & g_{k2} & 0 & 0 \\ 0 & 0 & g_{k3} & 0 \\ 0 & 0 & 0 & g_{k4} \end{vmatrix}$$

$$G_r = \begin{vmatrix} g_{r11} & g_{r12} & g_{r13} & g_{r14} \\ g_{r21} & g_{r22} & g_{r23} & g_{r24} \\ g_{r31} & g_{r32} & g_{r33} & g_{r34} \\ g_{r41} & g_{r42} & g_{r43} & g_{r44} \end{vmatrix}$$

$$H_s = \begin{vmatrix} h_{s1} & 0 & 0 & 0 \\ 0 & h_{s2} & 0 & 0 \\ 0 & 0 & h_{s3} & 0 \\ 0 & 0 & 0 & h_{s4} \end{vmatrix}$$

DISCLAIMER

This document was prepared as an account of work sponsored by an agency of the United States Government. Neither the United States Government nor the University of California nor any of their employees, makes any warranty, express or implied, or assumes any legal liability or responsibility for the accuracy, completeness, or usefulness of any information, apparatus, product, or process disclosed, or represents that its use would not infringe privately owned rights. Reference herein to any specific commercial products, process, or service by trade name, trademark, manufacturer, or otherwise, does not necessarily constitute or imply its endorsement, recommendation, or favoring by the United States Government or the University of California. The views and opinions of authors expressed herein do not necessarily state or reflect those of the United States Government thereof, and shall not be used for advertising or product endorsement purposes.