

176
10-31-83

85 (2)

NOV 1986

I-11818

Dr. 1874-0

DOE/NASA/0207-1
NASA CR-168075
HAC F107-500-5

Modular Photovoltaic Stand-Alone Systems Phase I Final Report

George J. Naff and Neil A. Marshall
Support Systems
Hughes Aircraft Company

February 1983

**DO NOT MICROFILM
THIS PAGE**

Prepared for
NATIONAL AERONAUTICS AND SPACE ADMINISTRATION
Lewis Research Center
Under Contract DEN 3-207

for
U.S. DEPARTMENT OF ENERGY
Conservation and Renewable Energy
Division of Photovoltaic Energy Technology

MASTER

DISCLAIMER

This report was prepared as an account of work sponsored by an agency of the United States Government. Neither the United States Government nor any agency thereof, nor any of their employees, makes any warranty, express or implied, or assumes any legal liability or responsibility for the accuracy, completeness, or usefulness of any information, apparatus, product, or process disclosed, or represents that its use would not infringe privately owned rights. Reference herein to any specific commercial product, process, or service by trade name, trademark, manufacturer, or otherwise does not necessarily constitute or imply its endorsement, recommendation, or favoring by the United States Government or any agency thereof. The views and opinions of authors expressed herein do not necessarily state or reflect those of the United States Government or any agency thereof.

DISCLAIMER

Portions of this document may be illegible in electronic image products. Images are produced from the best available original document.

DISCLAIMER

This report was prepared as an account of work sponsored by an agency of the United States Government. Neither the United States Government nor any agency thereof, nor any of their employees, makes any warranty, express or implied, or assumes any legal liability or responsibility for the accuracy, completeness, or usefulness of any information, apparatus, product, or process disclosed, or represents that its use would not infringe privately owned rights. Reference herein to any specific commercial product, process, or service by trade name, trademark, manufacturer, or otherwise, does not necessarily constitute or imply its endorsement, recommendation, or favoring by the United States Government or any agency thereof. The views and opinions of authors expressed herein do not necessarily state or reflect those of the United States Government or any agency thereof.

Printed in the United States of America

Available from

National Technical Information Service
U.S. Department of Commerce
5285 Port Royal Road
Springfield, VA 22161

NTIS price codes¹

Printed copy: A10
Microfiche copy: A01

DO NOT MICROFILM
THIS PAGE

¹Codes are used for pricing all publications. The code is determined by the number of pages in the publication. Information pertaining to the pricing codes can be found in the current issues of the following publications, which are generally available in most libraries: *Energy Research Abstracts (ERA)*; *Government Reports Announcements and Index (GRA and I)*; *Scientific and Technical Abstract Reports (STAR)*; and publication, NTIS-PR-360 available from NTIS at the above address.

Modular Photovoltaic Stand-Alone Systems, Phase I Final Report

DOE/NASA--0207-1

DE84 001694

George J. Naff and Neil A. Marshall
Support Systems
Hughes Aircraft Company
Long Beach, California 90810-0933

DISCLAIMER

This report was prepared as an account of work sponsored by an agency of the United States Government. Neither the United States Government nor any agency thereof, nor any of their employees, makes any warranty, express or implied, or assumes any legal liability or responsibility for the accuracy, completeness, or usefulness of any information, apparatus, product, or process disclosed, or represents that its use would not infringe privately owned rights. Reference herein to any specific commercial product, process, or service by trade name, trademark, manufacturer, or otherwise does not necessarily constitute or imply its endorsement, recommendation, or favoring by the United States Government or any agency thereof. The views and opinions of authors expressed herein do not necessarily state or reflect those of the United States Government or any agency thereof.

February 1983

Prepared for
National Aeronautics and Space Administration
Lewis Research Center
Cleveland, Ohio 44135
Under Contract DEN 3-207

NOTICE

PORTIONS OF THIS REPORT ARE ILLEGIBLE.

It has been reproduced from the best available copy to permit the broadest possible availability.

for
U.S. DEPARTMENT OF ENERGY
Conservation and Renewable Energy
Division of Photovoltaic Energy Technology
Washington, D.C. 20545
Under Interagency Agreement DE-AI01-79⁶ET20485

MASTER

TABLE OF CONTENTS

		Page
1.0	SUMMARY	1-1
1.1	Overview	1-1
1.2	Discussion of Results	1-2
1.3	Conclusions	1-3
2.0	INTRODUCTION	2-1
2.1	Scope of Present Work	2-2
2.2	Relevance of the Material Reported to General Field	2-2
2.3	Purpose of Subject Effort, Precisely Defined	2-2
3.0	ANALYSIS OF BOS ELEMENTS	3-1
3.1	Summary	3-1
3.2	Identification of BOS Elements	3-1
3.3	Array Structures, Foundations and Site Preparation	3-1
3.4	Array Field Wiring & Interconnects	3-15
3.5	Power Conditioning and Control	3-27
3.6	Energy Storage	3-42
3.7	Load Management Strategies	3-50
3.8	Load Management (LM) and Battery State-of-Charge (SOC)	3-52
3.9	DC Power Switching and Interruption	3-60
3.10	Electrical Protection	3-66
3.11	Environmental Protection of Batteries	3-70
3.12	Field Installation and Operations	3-76
3.13	Operations and Maintenance	3-78
3.14	Specification, Codes, and Standards	3-78
4.0	CONCEPTUAL DESIGN OF STAND-ALONE MODULAR SYSTEMS	4-1
4.1	Conceptual Design Rationale	4-1
4.2	Environmental Specifications	4-1
4.3	Baseline Conceptual Design Guidelines and Configurations	4-3
4.4	Common Attributes and Requirements	4-3
4.5	Panel Support Structures and Foundations	4-4
4.6	Array Field Layout and Wiring Topology	4-5
4.7	Power Controller Electrical Configuration	4-5
4.8	Energy Storage	4-6
4.9	Electrical Protection	4-6
4.10	Conceptual Design Candidates	4-8
4.11	Summary of Characteristics	4-25
4.12	Hughes Recommendations for Three Preliminary Design Candidates	4-25
4.13	Rationale for Final Selection and LCC Determination	4-25
4.14	Life Cycle Cost (LCC) Summary for Conceptual Designs	4-29

		Page
5.0	PRELIMINARY DESIGN OF STAND-ALONE MODULAR SYSTEMS	5-1
5.1	Overview	5-1
5.2	Analytical Findings	5-1
5.3	Preliminary Design Review of Systems V, VI and VII	5-2
5.4	Results of the Preliminary Design Review	5-2
5.5	Preliminary Designs Life Cycle Cost (LCC)	5-15
6.0	FINAL MODULAR DESIGN	6-1
6.1	Introduction	6-1
6.2	Array Structures and Foundations	6-1
6.3	PV System Electrical Configuration	6-1
7.0	Engineering Drawings	

APPENDIXES

A:	Parametric Cost Models of Key Components of Charger Regulators	A-1
B:	Temperature Control of Batteries by Means of Underground Storage	B-1
C:	SOLARLOK Connector System	C-1
D:	Batteries: Manufacturers' Data	D-1
E:	Product Specification, Solar Cell Module	E-1
F:	Lightning Protection	F-1

1.0 SUMMARY

1.1 Overview

The primary objective of Contract DEN3-207 was to develop a family of modular stand-alone power systems that covered the range in power level from 1 kw to 14 kw. Products within this family were required to be easily adaptable to different environments and applications, and were to be both reliable and cost effective. Additionally, true commonality in hardware was to be exploited, and unnecessary recurrence of design and development costs were to be minimized; thus improving hardware availability. Assurance of compatibility with large production runs, was also an underlying program goal.

A secondary objective was to compile, evaluate, and determine the economic and technical status of available, and potentially available, technology options associated with the balance of systems (BOS) for stand-alone photovoltaic (PV) power systems. The secondary objective not only directly supported the primary but additionally contributed to the definition and implementation of the BOS cost reduction plan. The power systems considered in this contract were PV stand-alone (no utility grid backup) DC systems utilizing flat plate silicon solar cell modules. The study was expanded to include modular systems of fractional kilowatt power levels with ratings from 1/4 power unit (PU) approximately 320 watts pk, to 16 power units (PU) 20,48 kW pk. (Forty 1 ft x 4 ft PV modules, each delivering 32 watts, were used for establishing the basic PU value; the actual power of a PU will vary from this nominal value proportionally to the power rating of a given PV module).

The systems were configured for world-wide application within a general environmental temperature range of -15°C to $+15^{\circ}\text{C}$, and had limited but acceptable performance in adverse insolation environments. The central thrust of the design was directed toward sun-belt (moderate temperature/equatorial) applications requiring reliable (but not necessarily uninterruptible) power from the photovoltaic energy source. Basic BOS elements considered were the photovoltaic module/ panel support structures, the battery protection and charge controls, lightning and fault protection (and other protection against abnormal or out-of-tolerance electrical events), load management, instrumentation and diagnostics, electrical/mechanical installation, and checkout and operation. Economic analysis and cost trade offs of the BOS elements were ongoing tasks in the effort.

Hughes has completed the work, directed or implicit in Phase I of subject contract. The program plan was executed in full accordance with stated NASA LeRC requirements and contract obligations; it featured a time phased effort starting with background research, functional, design and cost analysis and evaluation of options of candidate BOS elements. Subsequently, an orderly system design sequence was developed, starting with conceptual design, and progressing through preliminary design into the final design effort evolving the baseline modular system.

This report makes reference to certain manufacturers' products and their performance characteristics. Neither the Hughes Aircraft Company, its affiliates or subcontractors, nor any of their employees makes any warranty, nor assume any legal liability or responsibility for the accuracy, completeness or usefulness of the manufacturers' products or characteristics, nor represents that the products' use would not infringe on privately owned rights.

1.2 Discussion of Results

The technical results of the program have been meaningful. Major objectives were met and a modularly expandable design satisfying both cost and performance requirements has resulted. Excluding the PV modules and the batteries, the balance of the fabrication and assembly designs developed is straightforward, involving no unusual procedures or processes.

Power Storage

Hughes hoped that evaluation of the BOS options for energy storage would lead us into operationally practicable devices and techniques that were cost competitive and exhibited a higher energy storage density than the lead acid battery. Such was not the case: the lead calcium version of this cell became the most formidable contender early on in the program and remained so throughout the competition. Initially, low head hydrostorage was a candidate; it was found to compare unfavorably as a primary storage media -- principally because of its very low energy storage density and site specific nature. It was however recognized that pumped water storage as a product, if for no other reasons than for village use and for irrigation, represented a highly effective way of utilizing the vital photovoltaic power resource that otherwise might have been wasted or rejected.

Load Management

The development of practical load management strategies was determined to be an essential requirement. Stand-alone system availability considerations, as analytically developed by the NASA LeRC staff, were important in developing representative scenarios for LOEP (loss of energy probability) and LOLP (loss of load probability) and in the mechanization of load management sensors and logic, as well as the power control prioritizing circuits. Once the basic performance attributes of any stand-alone system were established, the key to meaningful load management involved the battery state-of-charge (S.O.C.) during the discharge cycle. We reviewed and summarily analyzed options known to us for sensing S.O.C. One approach, that of a GO/NO-GO cell specific gravity sensor, ultimately became the most immediately desirable candidate device; it was subsequently incorporated into the control system design. This particular methodology permits a direct parametric assessment of S.O.C. Future development of simpler inferential methods are, however, indicated.

Power Collection

Our developmental goal of devising an optimal power collection and field wiring topology appears to have been achieved. The horizontal daisy-chain wired branches, with radial collectors reduce ancillary array hardware needs and facilitate fault isolation. These features enhance system reliability and energy delivery. The interconnection methods also lend themselves well to system hook-up by relatively unskilled personnel.

Power Control

Power control/conditioning received considerable emphasis during both the analytical and design phases of the program. Initially, this element was exhaustively reviewed and analyzed for all potentially viable alternatives for regulating the charging of the energy storage battery. The first findings

disclosed that most conventional charger-regulator circuits candidates did not vary broadly either in design time or in production costs. Minor direct leverage on life cycle costs (LCC) and lifetime energy costs (LEC) was therefore directly exercised by these circuits. However, choice of a regulator circuit and its characteristics with regard to minimization of charging stress did indeed exert significant leverage on LCC and LEC, principally because a functionally superior charger/regulator produces smoother incremental or multistate charging. This gentler charging regime should lengthen the service life of the battery and perforce reduce the number of replacement cycles required over a 20 year service lifetime. The Hughes series (relay/solid state hybrid) charger/regulator, operating in multilevel modes, provides these essential control characteristics.

Structures

PV panel support structure evaluation and design have resulted in a low-cost environmentally rugged BOS element. The Hughes Frameless Ballasted Tub or Planter Design is almost universally deployable. This design is optimally cost effective for stand-alone system applications.

Safety and Electrical Protection

In the area of safety and electrical protection, we have designed to minimize the extent, duration, and severity of outages at a cost consistent with the goals for other BOS elements and the system as-a-whole. It is most difficult and costly to make any electrical power generator "idiot-proof"; we have, however, maximized the safety of involved personnel through the use of approved electrical practices and materials, and straightforward and unambiguous operating and maintenance procedures. A ground fault relay is included for protection of errant personnel from this particular hazard.

1.3 Conclusions

To summarize, the major project objectives have been met: competitive, cost-effective designs have been evolved or specified for the major BOS subsystems; the system is safe, maximally modular, and expandable. In-house designed systems represent the present state of off-the-shelf technology as embodied in rugged, reliable, easily produced apparatus. Design life expectancy has been established at 20 years. Improvements do, however, exist for a number of the BOS elements and the central photovoltaic generators as well. To this end, the Hughes designed modular system is configured and partitioned such that individual BOS subsystems may be upgraded without major system redesign.

Several advanced electrochemical storage subsystems were originally considered as prime candidates for possible stand-alone deployment. These were REDOX, the "new" Nickel-Iron Battery, the Iron-Air Cell, the Nickel-Hydrogen Cell, the Nickel-Zinc Battery, the Zinc Bromine and the Zinc-Chlorine couples. REDOX and the Zinc-Bromine battery appeared to be those most further advanced in terms of "near" to "intermediate" term application to stand-alone terrestrial PV power. In the foreseeable future, any one of a number of advanced storage systems reaching production maturity could be retrofitted into our system designs with minimal travail. Similarly, the array field design is not overly sensitive to module dimensions or characteristics.

2.0 INTRODUCTION

Terrestrial photovoltaics is an emerging power technology of high promise. Early proponents recognized that the contribution of this renewable energy source could be significant in providing power to remote, isolated sites throughout the world. A number of developmental, analytical, and demonstration projects were therefore undertaken in the Department of Energy (DOE) National Photovoltaic Program. The goals of these projects were proving design, operating principles, and reliability of stand-alone systems, and economically meeting the power needs of these remote, isolated locations. During these projects, it became apparent that stand-alone PV would ultimately need both greater flexibility and lower cost for meeting a variety of dispersed power needs. It was also recognized that site-to-site differences involved specific equipment complements, not major disparities in the basic design requirements. The stage was therefore set for exploring a number of optimal expandable modular configurations with broad stand-alone applicability.

There is not a unique, simplistic solution to developing low cost stand-alone photovoltaic systems. The solar cell was the principal high technology item pacing optimally cost effective utilization of these systems. Although extensive government supported effort was underway in evolving low-cost photovoltaic cells and modules, little had been accomplished in developing low cost balance of systems (BOS). The design and specification of the balance of systems appears to be relatively straightforward, but highly influenced by the state of the art and cost of BOS components, which are mostly products of mature technologies. A systematic and comprehensive effort was initiated, therefore, to evaluate the technology options and costs of BOS elements and the designs of modular photovoltaic systems to determine which components and systems configurations are amenable to further developments, modifications, and cost reductions.

2.1 Scope of Present Work

The DEN3-207 contract covered the development of a family of modular stand-alone photovoltaic power systems. Power ratings were from less than 1 kWp to nominal maximum outputs of 15 kWp. These modularly expandable systems featured a high degree of hardware commonality to eliminate recurrent design and development costs and to reduce production costs by facilitating large production runs. The project also involved a cost-reduction effort to reduce the BOS elements cost and the lifetime costs of energy produced by these systems. The scope of work of this contract included technical activity in two sequential phases: Phase I, modular system design, and Phase II, constructing and evaluating of the selected modular final design developed under Phase I, . Phase I, which is reported here, was executed in several tasks, all essentially sequential with well defined milestone achievements. These tasks included: a) analyzing and evaluating BOS elements and cost; b) conceptual designs of prescribed alternative systems; c) preliminary system design, again with several approach options; and d) final system design, design review, and documentation. Results of Phase II, including hardware development and system fabrication and test, will be documented in the Phase II final report.

2.2 Relevance of the Material Reported to the General Field

The stand-alone designs developed under this project and the applications data presented will be of direct interest to any group/agency seeking a cost effective solution to the suppling village or remote power by terrestrial photovoltaic generators. Remote power applications dictate that photovoltaic power system designs offer high operational reliability and longevity. These systems, to be deployable universally with a minimum of site specific engineering, will satisfy program objectives.

2.3 Purpose of Subject Effort Precisely Defined

The purpose of this effort has been to advance the state of the art of stand-alone photovoltaic power systems by creating a family of cost effective modular power systems that would be available without custom design, for a wide variety of applications and environments, over a broad range of power outputs and usage. Emphasis has also been placed upon development and specification of BOS elements that exert maximum beneficial leverage on system life cycle costs.

3.0 ANALYSIS OF BOS ELEMENTS

3.1 Summary

Section 3.0 traces the conduct of Task I through the following sequential phases:

- o Identification and listing of BOS element options.
- o Developing the rationale for assessing cost-effective alternatives.
- o Evaluating performance, cost effectiveness, and leverage potential of each option.
- o Recommending and ranking options for reduced energy costs and improved performance.
- o Development of optimal approach for subsequent conceptual designs.

The thrust of Task I was to accurately project BOS element costs as a function of application, type of device, and present and future state of that technology. The cost of present stand-alone systems and equipment was analyzed, as was the potential impact of technology advancement upon particular BOS functions, performance, and cost.

3.2 Identification of BOS Elements

Hughes projected a number of possible options in BOS element categories corresponding to those given in Exhibit A of the governing Statement of Work. This listing of options, presented in Figure 3.2-1, was drawn from advancements and innovations developed during the initial Phase I efforts, as well as from prior and ongoing work pursued by others. The listings were used as a point of departure for subsequent evaluations. Funding and time schedules limited the extent of in-depth exploration of each promising artifact in each BOS category.

3.3 Array Structures, Foundation, and Site Preparation

3.3.1 Guidelines and Criteria

Guidelines were developed for this important BOS element. The major criteria used to develop recommendations for a superior cost-effective design included:

- o Economy of manufacture ease of transport, and installation.
- o Deployment on a world wide basis, along with a capability of being fabricated by diverse sources.
- o Avoidance of using exotic design materials, techniques, or processes.
- o Modular expandability from 1/4 Power Unit (P.U.) through the 16 P.U. level. (One P.U. was chosen to represent a nominal one kilowatt peak power system).
- o Compatible with installation and usage in all terrains and with several different foundation designs.
- o Survival without damage in a worst case installation environment.
- o Ease of service and a twenty year operational lifetime survival.
- o No conflict with the integrity of-or unacceptable cost impact upon-other functional subsystems.

Within this framework the most promising candidates for array panels, foundations, footings, and integrated structures were investigated and evaluated.

ARRAY STRUCTURES & FOUNDATIONS

PANEL SUPPORT STRUCTURE

- JPL LOW COST
- HUGHES MODULAR "FRAMELESS"
- OTHER

FOUNDATIONS

- BURIED
- SURFACE
- ANCHORS

ARRAY FIELD WIRING & INTERCONNECTS

POWER WIRING TOPOLOGY

- RADIAL (STAR) WITH DISPERSED BATTERY/REGULATOR GROUPINGS
- TAPERED BUS
- RADIAL WITH CENTRAL BATTERY/REGULATOR GROUPINGS

INSTALLATION DESIGN

- DIRECT BURIAL RHW, RHW OR EQUIVALENT PER NEC/JUL AND ELECTRIC UTILITIES PRACTICES
- NON-METALLIC RIGID CONDUIT WITH TW, THW, ETC.

POWER CONDITIONING & CONTROL

CHARGER REGULATOR CIRCUITS

- SHUNT CONTACTOR (ON-OFF)
- SHUNT TRANSISTOR (ON-OFF)
- SHUNT TRANSISTOR (ON-OFF) ON ARRAY TAP
- SERIES REGULATOR (ON-OFF)
- HUGHES TRI-STATE CONTROLS
- HUGHES MULTILEVEL SERIES CONTROLS

MODULAR EXPANDABILITY

- REPLICATION OF SMALLEST POWER INCREMENT
- MODULARLY EXPAND (REPLICATE) INTERMEDIATE LEVEL REGULATORS, DELETE POWER SWITCH SUBASSEMBLIES FOR LOWER POWER LEVELS
- MINIMUM COMPLEMENT OF DISCRETE POWER LEVELS

BATTERY STORAGE (OFF-THE-SHELF)

BATTERIES

- C&D SHALLOW CYCLE P.V
- WILLARD (WISCO)
- ESB PHOTOVOLTAIC (Ca-Sb HYBRID)
- DELCO FREEDOM 2000 SERIES
- THOJAN RV ELECTROMOTIVE
- NI CAD (POCKET PLATE)
- C&D TYPE OP Pb Ca DEEP DAILY DISCHARGE CELL

ENCLOSURES FOR ENVIRONMENTAL PROTECTION

- HUGHES MODULAR ARRAY FRAME PACKAGES
- PRE-FAB MODULAR KITS
- LOCAL CONSTRUCTION (AS-BUILTS)

MODULAR EXPANDABILITY

- MULTI-CELL FACTORY PACKAGES WITH ASCENDING A-H CAPACITY
- MINIMAL CELL COMPLEMENT FOR ALL POWER LEVELS (OPTIMAL SPECTRUM OF A-H RATINGS)
- STANDARD PRODUCTION CELLS & PACKAGES

ELECTRICAL PROTECTION

GROUNDING

- CONCRETE-ENCASED ELECTRODES
- GROUND ROD CLUSTER
- BURIED METALLIC COUNTERPOISE

EQUIPOTENTIAL BONDING

- DEPENDENCE UPON STRUCTURAL BONDING ONLY
- SUPPLEMENTAL ALUMINUM OR GALVANICALLY COMPATIBLE STRAPS

VOLTAGE LIMITATION

- Z_NO-MOV (METALLIC OXIDE VARISTOR)
- Z_NO-MOV WITH SUPPLEMENTAL GAP

SHIELDING

- BURIED SINGLE WIRE
- CONCENTRIC GROUNDS/NEUTRAL

LIGHTNING

- LIGHTNING RODS ONLY, OR NONE REQUIRED
- LIGHTNING ROD(S) + AERIAL COUNTERPOISE

GROUND FAULT PROTECTION

- ESTABLISH OPTIMAL SECTIONALIZING LEVEL

EMV/SURGE CONTROL

- MAIN BUS FILTERING
- SUB-BUS SNUBBERS
- SECTIONALIZED VOLTAGE CLAMPS

DC CURRENT INTERRUPTION

- HYBRID STATIC SWITCH
- SNUBBERS
- MAG. BLOW OUT
- FORCED CURRENT ZERO

LOAD MANAGEMENT

CONTROL APPROACH

- CENTRALIZED AT THE PV SYSTEM
- DISPERSED AT POINT-OF-USE
- "SMART" VIS-A-VIS "REACTIVE"

LOAD PRIORITIZATION STRATEGY

- PROGRESSIVE LEVELS OF ESSENTIALITY
- CRITICAL UNINTERRUPTIBLE ONLY SPECIAL CASE

BATTERY STATE OF CHARGE DETERMINATION

- INDIRECT POWER FLOW BUDGETING & METERING (CULOMBMETER)
- ASSESSMENT OF ELECTROCHEMICAL PARAMETERS
- TWO TERMINAL I-V MEASUREMENTS (PULSE/HIGH RATE ETC)

ELECTRICAL POWER APPARATUS (OTHER)

CONTROL/POWER CIRCUITS & ENCLOSURES

- REPLICATE IDENTICAL PACKAGES STARTING WITH BASIC, LOWEST POWER LEVEL UNIT
- MODULARLY EXPAND (OR CONTRACT) FROM SEVERAL STANDARD POWER LEVEL CONTROL PACKAGES

OPERATIONS & MAINTENANCE

- FIELD REPAIR AT SUBASSEMBLY LEVEL
- FIELD REPLACEMENT ONLY
- NO REPLACEMENT IF PREDETERMINED DEGRADATION LEVEL ACCEPTABLE
- REQUIRES SKILLED OPERATOR AND MAINTENANCE SPECIALIST
- PRINCIPALLY UNATTENDED EXCEPT FOR PERIODIC SURVEILLANCE

LOGISTICS

- KIT & SHIP SYSTEMS FROM STATESIDE
- PROCURE FROM ALTERNATE REGIONAL SOURCES
- MAXIMIZE USE OF ON-SITE & LOCAL AS-BUILTS

FIGURE 3.2-1. IDENTIFICATION OF DESIGN OPTIONS FOR BOS ELEMENTS

3.3.2 Array Field Panel Structures

In excess of twenty basic variants of low-cost array superstructures (as well as foundations) have been designed, manufactured and installed. Included are the configurations generated and analyzed by Bechtel, JPL, Batelle, Martin Marietta, NASA LeRC, et al., as well as those embodied in the various flatplate PRDA's and other DOE stand-alone demonstration systems. A number of these approaches were initially rejected because of almost unique applicability to intermediate sector utility interactive systems; others showed little promise as the results of marginal cost effectiveness and/or using materials and construction methods incompatible with remote, stand-alone applications. The configurations considered worthy of further analysis include those given in Figures 3.3-1, 3.3-2, 3.3-3, 3.3-4. Other designs did not appear to embody any singular features: these were classified generically and embodied in the concepts illustrated.

Because of the extensive amount of analysis data available and the public (PV community) exposure, the JPL "low-cost" concept was thoroughly examined; it merited specific identification as an integrated concept. The JPL "low-cost" roll-formed metal panel was directed toward large area panels (typically 8 ft. x 20 ft.) and large volume production for intermediate sector use. Trench excavation would at the minimum require a trencher and more likely a back-hoe. Shipping the large wooden structural elements and sheet metal forms posed a logistic problem. Our conclusion was that this design would be both difficult and costly to apply to PV systems deployed world wide.

However, the availability of the JPL design data was, however, most valuable in assisting in developing improved approaches. The panel structures for an FPUP procurement for NWC China Lake were under design. Evaluation of these designs against the criteria cited under 3.1 preceding was made, and these designs appeared to meet stated guidelines.

The Hughes panel designs (depicted in Figures 3.3-2, 3.3-3, and 3.3-4) consist of two vertical side support channel members 10' long, joined by horizontally oriented PV modules. The channel members have 3" flanges and 2" sides. This size yields a suitable section modulus and allows ample space for fastener access. It accommodates a wide range of module types and widths. The channels are oriented with their sides facing inward, placing the 3" channel surface in line with the outer edges of the modules to form the panel. Adjacent panels thus share common front mounting stanchions and rear support legs. The nominal module area per panel is 4 ft. x 8 ft. The 10 ft. long panel channels provide the additional length needed for module ground clearance.

3.3.3 Panel Economy

JPL's "low-cost panel" frame costs were used as a "standard" to evaluate the cost effectiveness of the Hughes "frameless" panel. Cost versus quantity curves for these panels are given in Figure 3.3-5. The Hughes panel is cost effective because the modules are used as structural elements. This use eliminates the need for panel frame members on two sides of the "frame", thus allowing the same panel side support channels to be used on a variety of module sizes without changing the basic geometry of the "frame." The channels are fabricated from cold-rolled 1010 alloy sheet steel, which has a yield strength of 44 kpsi. Small quantities of the channels are brake formed; large

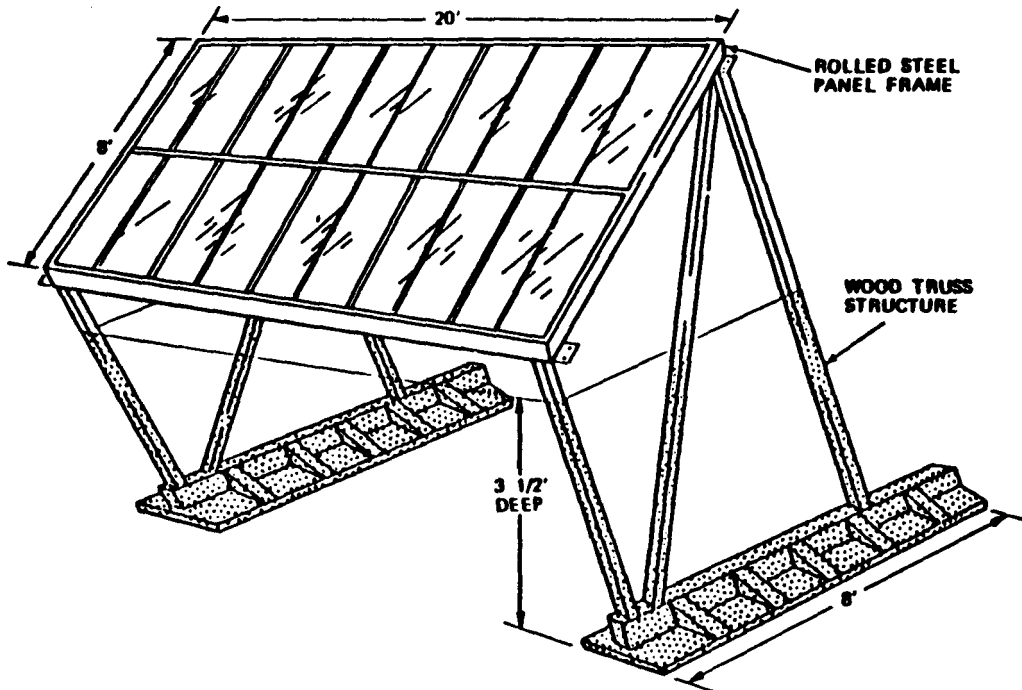

JPL Low Cost Structure/Foundation Concept
 FIGURE 3.3-1

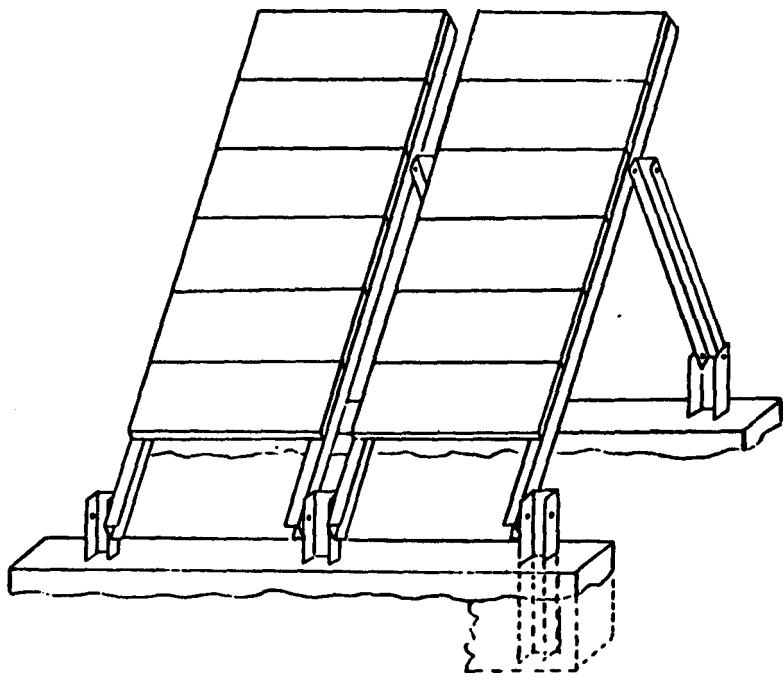

Concrete Curb Structure/Foundation
 FIGURE 3.3-2

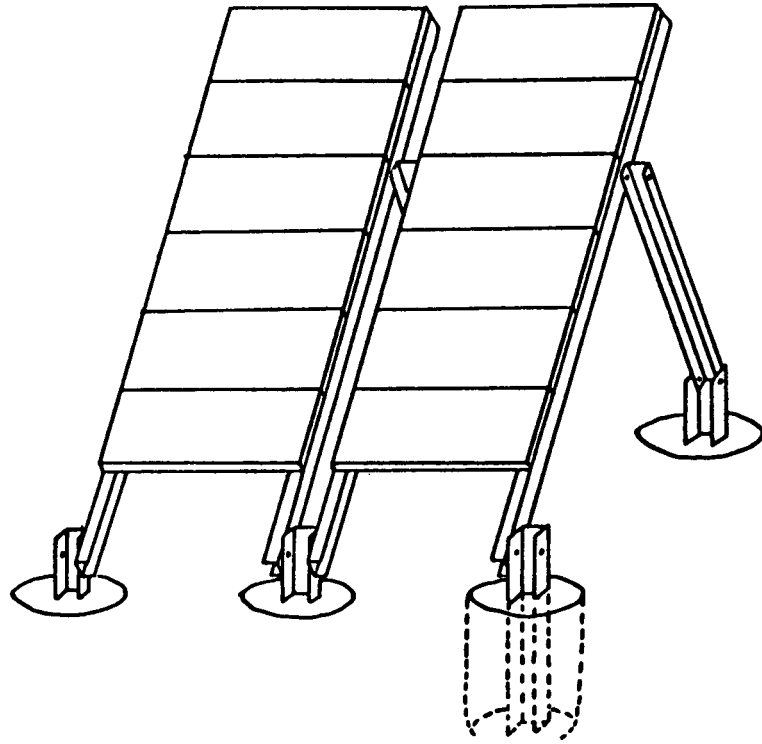

Post Hold Concrete Pier Structure/Foundation
FIGURE 3.3-3

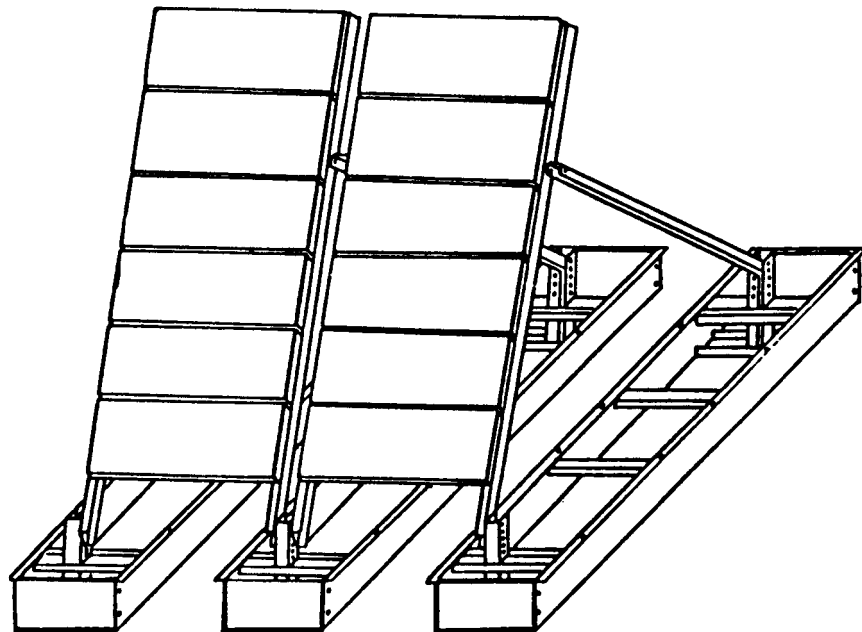

Ballasted Planter Structure/Foundation
FIGURE 3.3-4

EQUIVALENT ARRAY POWER AT NOC

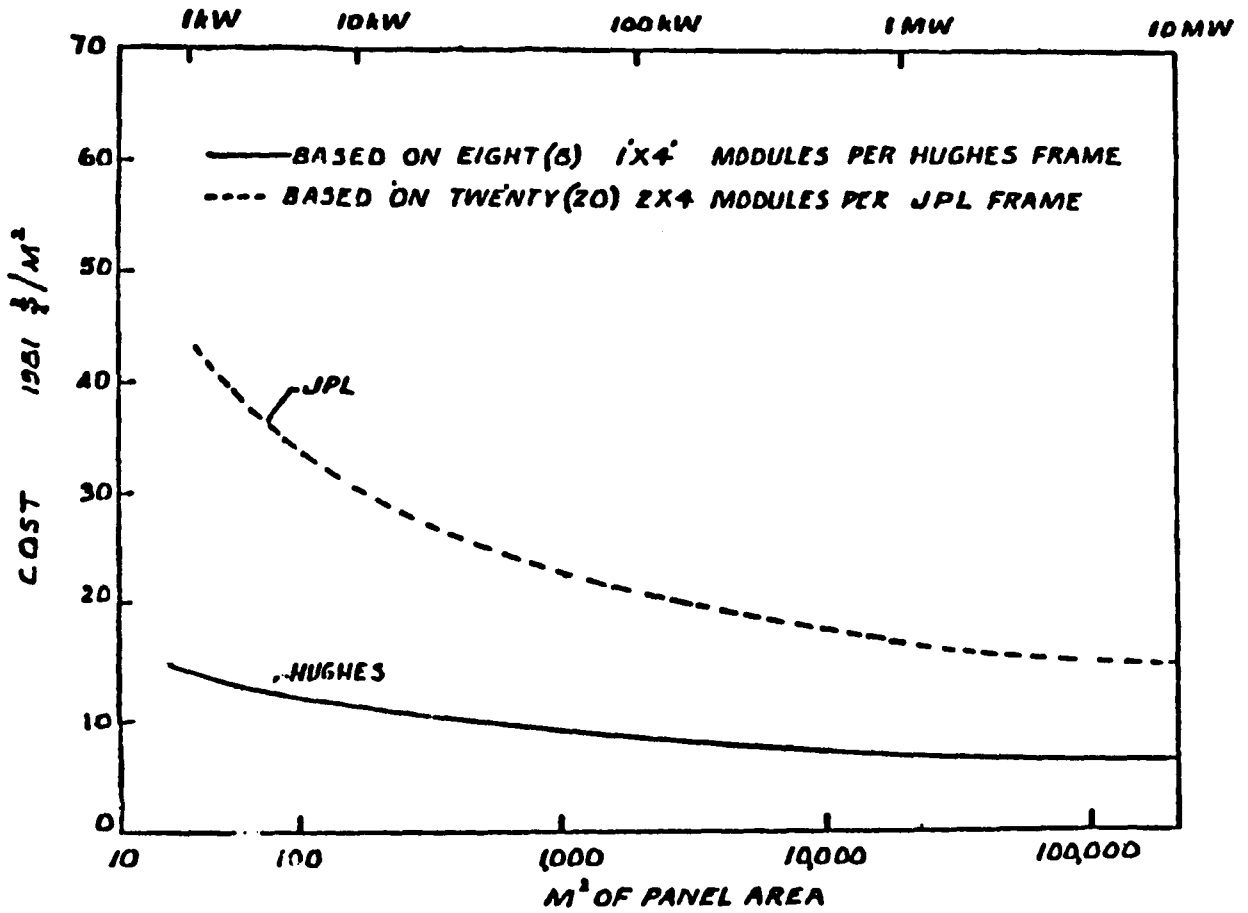

Panel Fram Costs
FIGURE 3.3-5

production runs would justify roll-form tooling. A significant cost advantage is realized by fabricating the frame members from flat stock. All module and frame mounting holes are simply punched into the flat stock on a tape controlled "strippit," at a cost of 10-15 cents per hole versus the 25-30 cents per hole required for drilling holes into standard structural channels. In large volume, this hole cost could be reduced by tooling permitting simultaneously punching of all holes.

3.3.4 Ease of Installation

The compact size and light weight of the Hughes panel were found to significantly enhance installation ease, safety, and economy.

Two men can readily handle and install a panel, eliminating the need for special cranes or lifting tools. Panels are laid flat at the installation site, attached to their front foundation supports, pivoted up to the proper tilt angle, and then attached to the rear support legs. Usually the common support leg from the preceding panel would have been in place to make the first rear attachment, thus eliminating the need to simultaneously raise the panel and one of its rear support legs.

Wiring and interconnection may proceed safely once the panels are physically in place. The overall height of the inclined panels is about 8 ft. assuming an inclination angle of about 30° from the horizontal. All panel wiring is thus accessible to personnel standing on the ground or on the integral battery platforms incorporated into the selected foundation designs. Ladders and their inherent risks are not required. For equatorial installations, panels will have to be temporarily tilted on the north or south side to avoid working under a low horizontal panel row.

Individual modules may be removed from a panel assembly by first disconnecting the integral module electrical connectors then physically removing them.

3.3.5 Terrain Considerations

The task of specifying alternate foundations for securing these panels to the varying terrains was then addressed. The following site selection factors were first reviewed:

1. Proximity to electrical load.
2. Orientation to sun.
3. Terrain/soil.
4. Contours/site preparation.
5. Accessibility.
6. Availability.
7. Climatic conditions.
8. Security/protection.

Of all these factors, the terrain/soil one was the most open to choice. The array site had to face the sun, be accessible, and be reasonably near the load. These requirements might be in conflict with requirements for installation under optimal soil/terrain conditions. Four main terrain types were characterized. Several foundation options, each best suited to a particular kind of terrain, were also developed. These founding options, and their specific terrain type compatibilities are reviewed in the paragraphs following.

3.3.6 Array Foundations

The primary terrain types to be dealt with when founding an array are:

1. Soft, level dirt or sand.
2. Hard, uneven earth, possibly with some rocks.
3. Dirt with a heavy rock concentration.
4. Solid rock.

Because most array sites involve two or more of these primary terrain types, the proposed footing designs had to apply to more than a single type of terrain. The four proposed designs and their primary terrain applications are:

1. Concrete curb footings - soft, level dirt.
2. Concrete post footings - hard, uneven rocky dirt.
3. Ballasted planter tubs - rock filled dirt.
4. Grouted rods with dry-pack feet - solid rock.

These array founding systems, with the exception of the solid rock mount, are all economical, simple, and straightforward to install. They utilize the panel itself or a simple alignment spacer as the major foundation stanchion aligning tool, thus requiring little accurate measuring and alignment. The material and installation costs for these founding systems for various quantities are presented in Figures 3.3-6, 3.3-7, and 3.3-8.

3.3.7 Concrete Curb Footings

A level array site, flat and free of rocks, is compatible with any of the first three array founding options. However, the curb footing (Figure 3.3-2) proved to be the most cost effective (Figures 3.3-6, 3.3-7, and 3.3-8). The curb trenches can also be used for the intracabling and the burial for wiring and grounding counterpoise. The cost savings of this methodology becomes more significant for higher system power ratings.

After the array field location has been determined, the curb foundations are installed as follows. The site, if not reasonably level, would first be graded. The trench digging method would be determined by the array size, location, and local labor costs. The trenching for small arrays could easily be done manually, assuming 50 feet of trenches per kilowatt of array power. The trench sizes required to withstand the wind and other environmental loads were determined to be approximately 6 to 8 inches wide by 2 ft. deep on the front foot, and 10 to 12 inches wide by 2 ft. deep on the rear foot. After trenching has been completed, the vertical panel support stanchions are placed in their approximate locations in the trenches and bolted to alignment spacers.

Elevation inaccuracies are easily remedied by tapping on raised stanchions and driving them into the trench bottom until their mounting holes are at the proper level. Concrete would be poured into the trenches up to ground level or slightly above. Formed curb tops are not required unless they support the array batteries depicted in Figures 3.3-9 and 3.3-10. After the concrete has cured, the alignment spacers are removed and replaced by the panels.

EQUIVALENT ARRAY POWER AT NOC

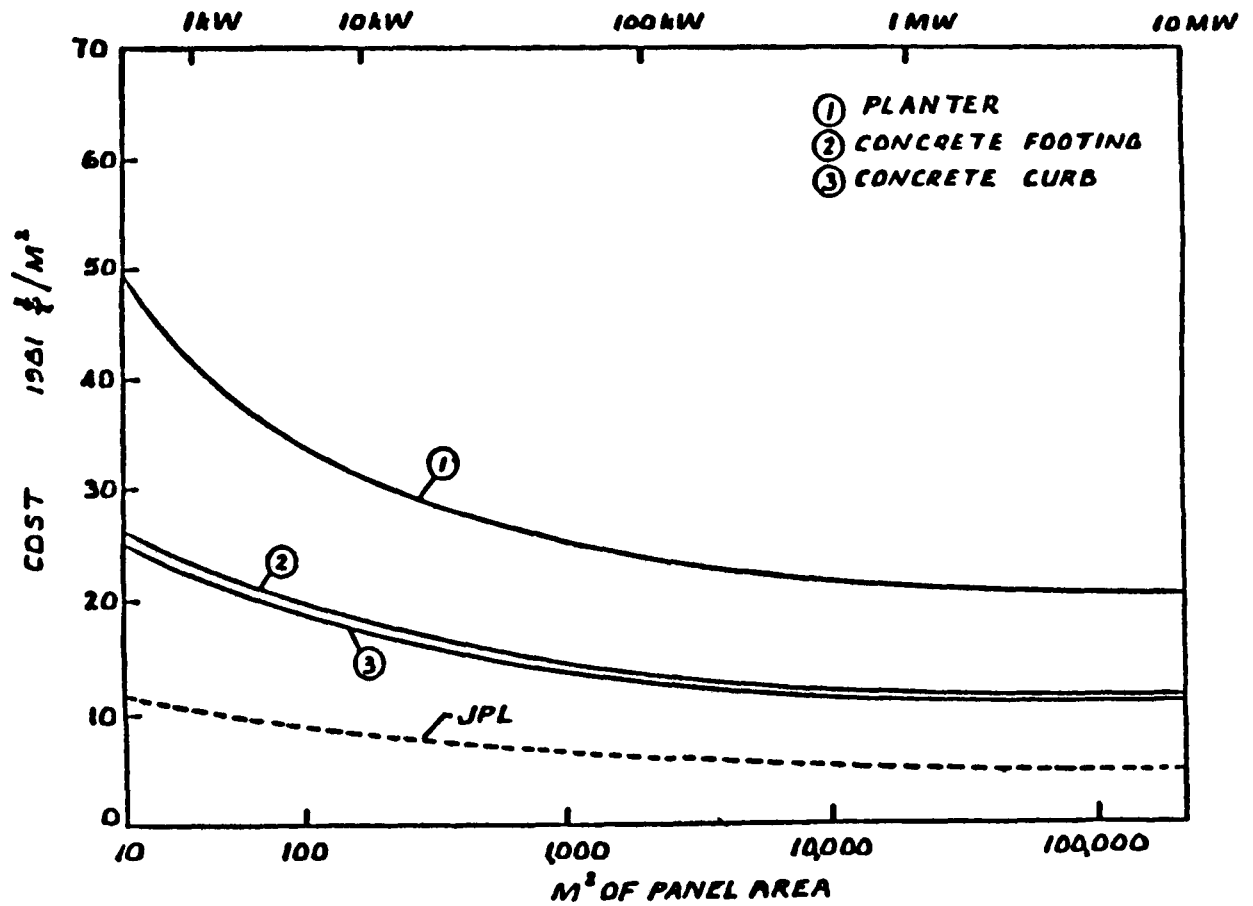

Foundation Material Costs
FIGURE 3.3-6

EQUIVALENT ARRAY POWER AT NDC

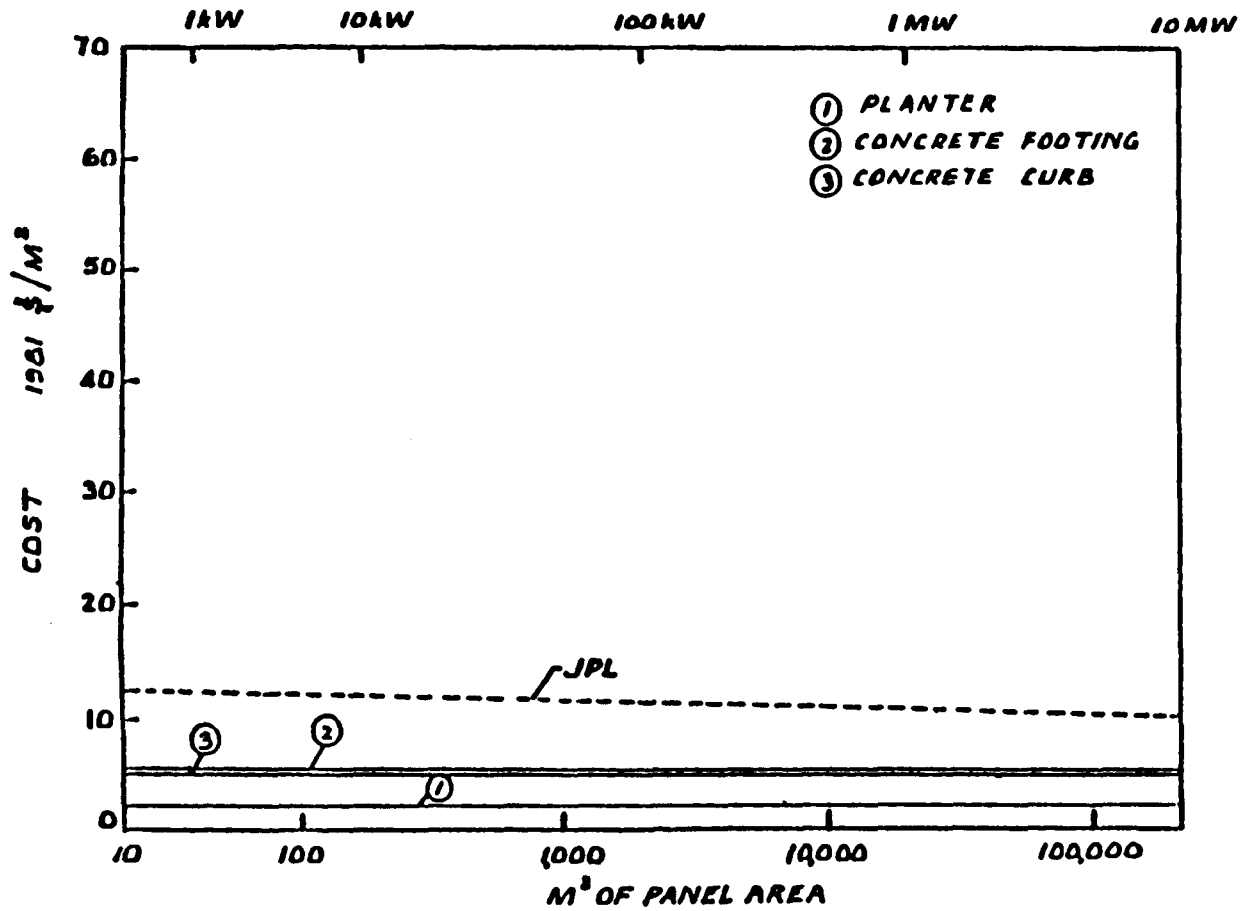

Foundation Installation Costs
FIGURE 3.3-7

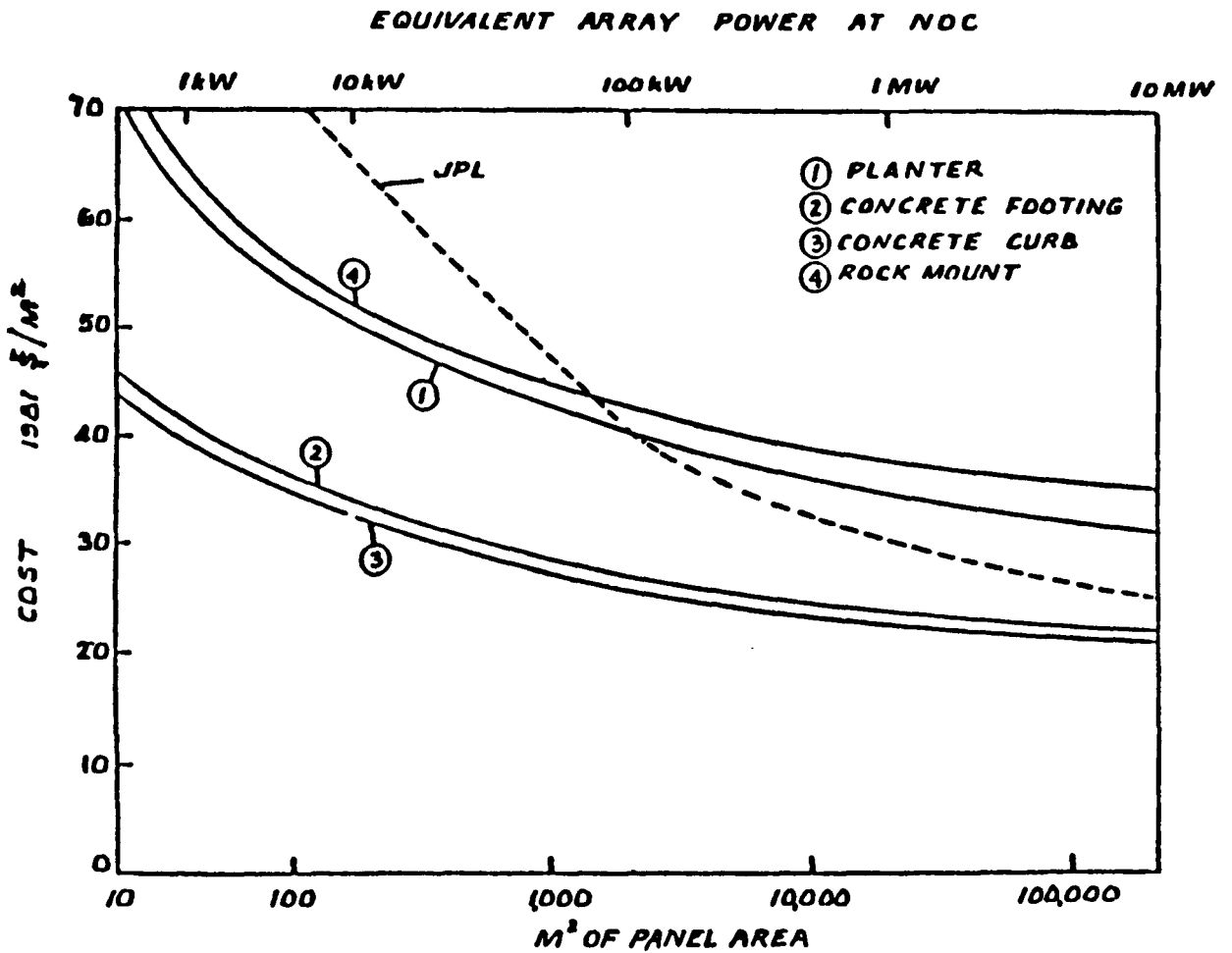

Installed Foundation and Structural Array Support Costs
FIGURE 3.3-8

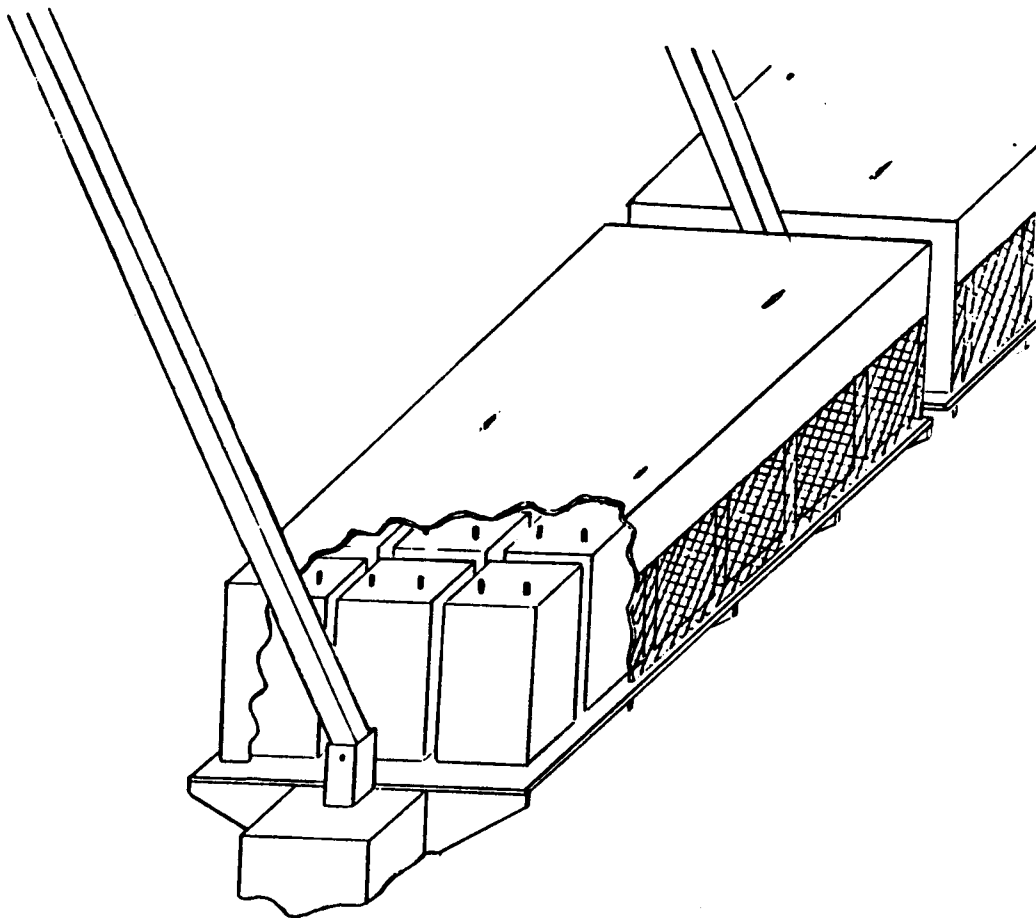

Batteries Supported on Concrete Posts
FIGURE 3.3-9

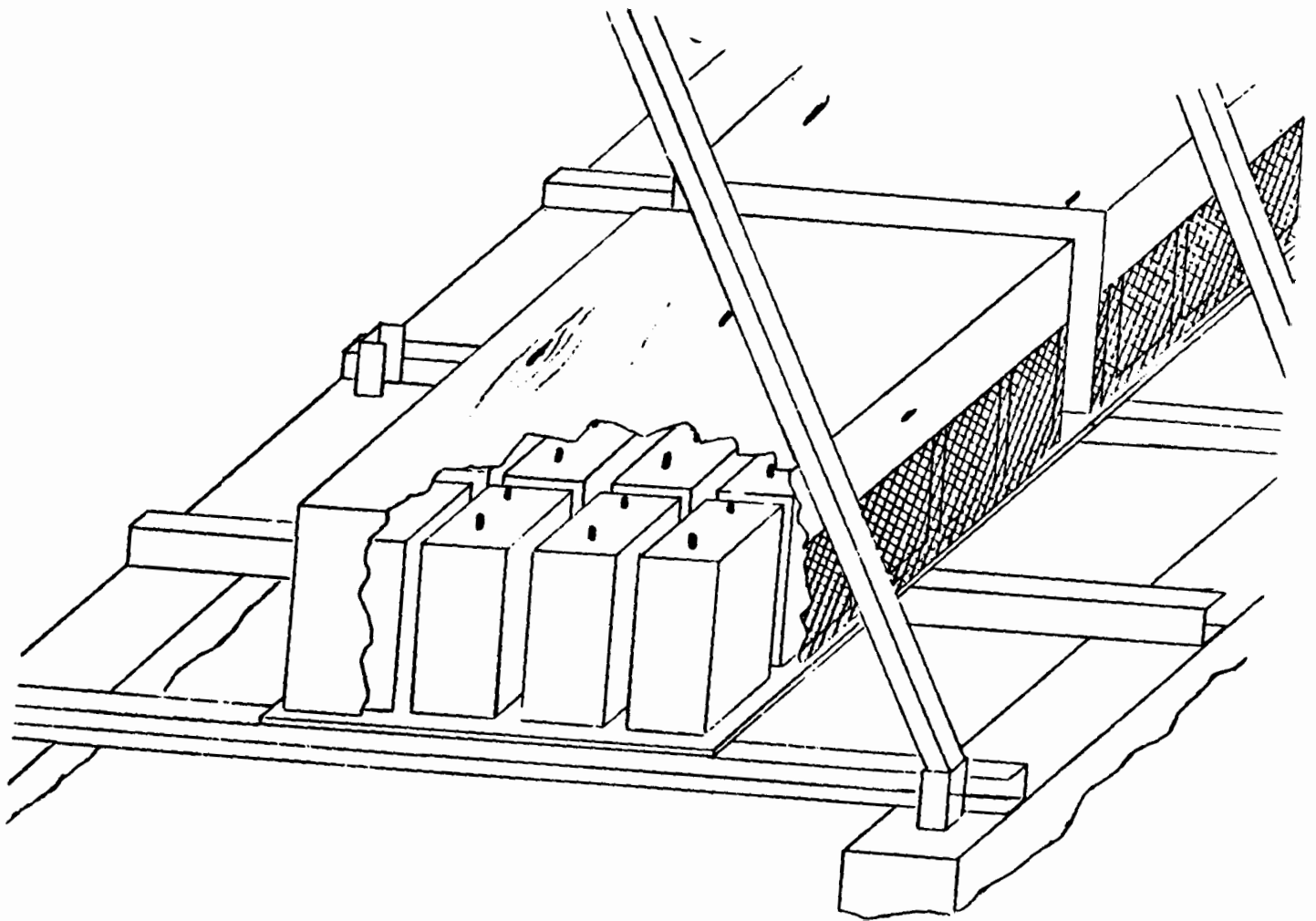

Array Batteries Supported on Concrete Curbs
FIGURE 3.3-10

The JPL "low cost" foundation concept exhibits the attributes of both the concrete curb footing and the ballasted planter tubs. It is similar to the concrete curb founding approach in that it requires continuous trenches prepared with reasonable care. It is similar to the planter method in that it depends upon bulk native material (in contrast to on the site cast concrete) for its structural rigidity, assurance of permanent positioning and invulnerability to upending moments.

3.3.8 Concrete Post Footings

Soil conditions, lack of trencher access, or concrete raw material shortage may preclude using the concrete curb. In these circumstances, concrete post footings may be deployed economically. This foundation, depicted in Figure 3.3-3, is similar to the curb footing, the major difference being the replacement of trenches with post holes. Post hole augers are portable, two-man operated; motor driven units can be carried to locations that are inaccessible to vehicles. Alternatively, an electrical demolition spade, powered by a small engine generator, may be employed effectively.

To install this foundation, post holes about 3 ft. deep and 1 foot in diameter would be dug at the points where panel support stanchions were required. Hole location inaccuracies would be remedied easily with a shovel when the stanchions were attached to the alignment spacers and sited. The remainder of the installation would be performed identically to the curb footing installation described previously.

3.3.9 Ballasted Planter Footings

Remote systems are frequently located on mountain peaks to power communication gear and other equipment. The Hughes FPUP China Lake installations are a good example. The soil is composed typically of rocks of various sizes in a soil matrix. Digging foundation holes or trenches could be expensive. The Hughes ballasted "planter" was developed for this application. While the planters material costs are the highest of the designs proposed (Figure 3.3-7), its installation is the lowest (Figure 3.3-8).

The planter (Figure 3.3-4) consists of a hot-dip galvanized sheet metal trough weldment with the panel support stanchions located at the ends. Installation involves locating the planter positions, clearing use areas of major rocks and vegetation, rough shovel grading of the planter pads, and placing the planters thereon. Spacer rods are then fastened between the adjacent planter stanchions to ensure easy acceptance of the array panels. Steel spikes are placed into the hole at each end of the trough bottom and driven into the rock/soil aggregate to ensure fixed location. The planter end closures are then bolted into place; the rocks, soil or sand bags, used to ballast the panels, also serve to lock in the spikes. The space between the lower lip of the end closure and the bottom of the trough, produced by the spike head thickness, allows rainwater to drain from the planter trough. With their ends in place, the planter troughs are filled with nearby rocks and/or dirt or sand bags. Wooden battery platforms are bolted across the planter's top flanges and the batteries installed. This founding design appears to have almost universal site applicability.

3.3.10 Solid Rock Mounting

Some installations, particularly those located on high mountain peaks, might need to be sited on solid granite terrain. An accepted method for interfacing with this terrain is to drill the rock, insert threaded studs with a nut at the lower end into the holes, align the studs and pack the studded holes with an expanding grouting. These studs are held in proper location and alignment by threading nuts on them down to the desired foot-top level, and by then placing properly sized and pre-drilled plywood foot-top forming plates over the studs. The plates are leveled to the proper height with the stop nuts and locked into position with additional nuts. The plates would be adjusted to the proper height and leveled before grouting the rods.

After the grouting has cured, concrete feet are formed under the plates with 2500 psi drypack concrete. After the concrete has cured, the plywood forming plates are removed, and the brake formed sheet steel stanchion feet are bolted to the studs. The cost of each footing is high because of the extensive preparatory labor content.

To be cost effective, this method requires that a number of panel assemblies be supported by a common set of footings. This method of support in turn requires additional horizontal rigidity. Adjacent panel sections share common feet similar to the other founding methods.

3.4 Array Field Wiring & Interconnects

3.4.1 Design Selection Criteria Guidelines

Power collection from dispersed PV field's elements involves several considerations: a) the method of interconnecting the modules to form the basic power block, b) the wiring topology of the integrated collection network, and c) the physical configuration of the actual interconnections.

A typical 1 ft.x 4 ft. module generates about 32 peak watts under normalized conditions. The output of a 2 ft. x 4 ft. module would be twice that, a nominal 64 watts. The systems under consideration have ratings from less than 1 kwp to 16 kwp. If no constraints are applied, a virtually unmanageable number of alternative approaches involving different circuit physical configurations and component ratings would exist.

A number of ground rules were therefore applied as follows:

1. Only two basic module ratings were used: the 1 ft. x 4 ft. module (32 Wp nominal) and the 2 ft. x 4 ft. module (64 Wp nominal).
2. AMP Solarlok connectors would be employed in intermodule wiring for reasons of suitability and optimal maintainability.
3. The minimum power block would be either 320 watts (150 VDC @ 2.13 ADC with 1 ft. x 4 ft. modules) or 640 watts nominal (150 VDC @ 4.3 ADC with 2 ft. x 4 ft. modules).
4. Wire size restricted to 10 AWG and 14 AWG to ensure compatibility with Solarlok connectors.

5. The standard 1st level modular assembly would be the 4 ft. x 10 ft. panel, housing either eight 1 ft. x 4 ft. modules, or four 2 ft. x 4 ft. modules.
6. The panel would be required to be only a physical or structural entity; its designation as a discrete electrical building block would be at the discretion of the designer.
7. The "octopus" panel configuration, that of making the series or parallel module interconnections in a central panel "J-Box," would be an acceptable alternative to direct module-to-module interconnect.
8. The baseline system would be required to generate 1 Kw pk under the following standard conditions:

Insolation: 100 mW/cm^2 ,

T ambient: 28°C

Air Density: Airmass 1.5

9. The baseline 1 kWp power rating is considered to be a nominal value and was established as the basic "one power unit," or 1 P.U., in the evaluation of alternative intermodule wiring configurations. Variations from this target rating were permitted. For example, the 1 P.U. nomenclature for an array field delivering 1.2 kWp was acceptable.

3.4.2 Inter-Panel/Module Wiring Topology

These alternatives and associated trade-offs shape the characteristics of the basic power building blocks and the overall array field topology. Flexibility, relative cost, maintainability, and freedom from shading losses are among the evaluative criteria. The circuits for six candidate topologies are given in Figures 3.4-1 through 3.4-6. These approaches, each of a nominal 1 power unit (P.U.) rating, are:

- A. Series connected blocks of 4 ft. x 8 ft. panels (32 sq ft. active area) to achieve a nominal 150 VDC branch circuit (Figure 3.4-1).
- B. Horizontal, folded Daisy chain of 1/2 panels, each of 4 parallel 1 ft. x 4 ft. modules (Figure 3.4-2).
- C. Horizontal Daisy-chaining of two folded rows of individual modules (2 each 1 ft. x 4 ft. in parallel) in adjacent panels to form a branch circuit (Figure 3.4-3).
- D. Series connected blocks of 4 ft. x 8 ft. panels with series parallel 15 volt 1 ft. x 4 ft. modules.
- E. Horizontal folded Daisy chain of 2 ft. x 4 ft. modules on adjacent panels.
- F. Horizontal folded Daisy chain of 1 ft. x 4 ft. modules on adjacent panels.

In Configuration A (Figure 3.4-1) each panel in the series string becomes a separate electrical entity rated 30 VDC @ 9.2 amps for the particular 1 ft.² x 4 ft. module type examined. At peak array current, the power loss due to I²R wire losses is approximately 0.44 percent. When the lower modules are differentially shaded, the entire array output is proportionally degraded. Maintenance ease is somewhat limited as the result of inherent difficulty of fault isolation without complete array shutdown.

Configuration B (Figure 3.4-2) treats a four parallel module, one-half panel block as the basic electrical entity. It is considered inordinately sensitive to shading losses because all of the half-panels are in series. An "octopus" arrangement, i.e., a separate current summing node for each 1/2 panel could decrease wire losses slightly; at 0.36 percent, these losses do not pose a problem.

Configuration C significantly reduces I²R losses to an estimated 0.04 percent. The folded horizontal daisy-chain minimizes intermodule wiring, and some immunity to lower module shading is provided by the two parallel branches. While the maintainability is not yet optimal, it is improved over that of the previous configurations.

Configuration D is a variant of Configuration A; it should be slightly more immune to differential shading. Power losses are about 0.36 percent. This series panel configuration (with parallel modules) does not result in non-ambiguous fault diagnosis. Fault isolation, partial restoration of service in the event of a partial panel outage, is possible, but not at all convenient.

Configuration E creates two horizontal daisy-chained strings of the physically folded type. The basic building block is the 2 ft. x 4 ft. module producing 15 VDC at 4.26 ADC (64 Wp nom). Two 150 volts output branches are formed; wiring losses are estimated at 0.2 percent. Half power can be maintained in the event of a faulted branch.

Configuration F is that of a folded-horizontal daisy chain of ten each 1 ft. x 4 ft. modules. The output of each of the four strings is 15 VDC @ 2.16 ADC. Power losses are estimated at about 0.15%. Maintainability should be excellent.

3.4.3 Power Collection Topology

Section 3.4.2 was concerned with some alternative configurations for module-to-module wiring and panel interconnection. Several potentially cost-effective power "building-blocks" were also identified. At some point the power generated by the dispersed interconnected modules will have to be summed on a battery or load bus. The selection of a particular power collection network design is partially independent of the precise configuration adopted for interpanel/module wiring. Several of the most promising options are:

- a. A tapered ampacity bus or "Christmas Tree."
- b. Loop power collection with a single prime bus.
- c. Radial power collection.

The advantages and disadvantages of these three basic alternatives are explored in the paragraphs following:

3-18

PANELS CONSISTING OF 8 1' X 4' MODULES 15 VDC EA. AT 2.3 AMPS

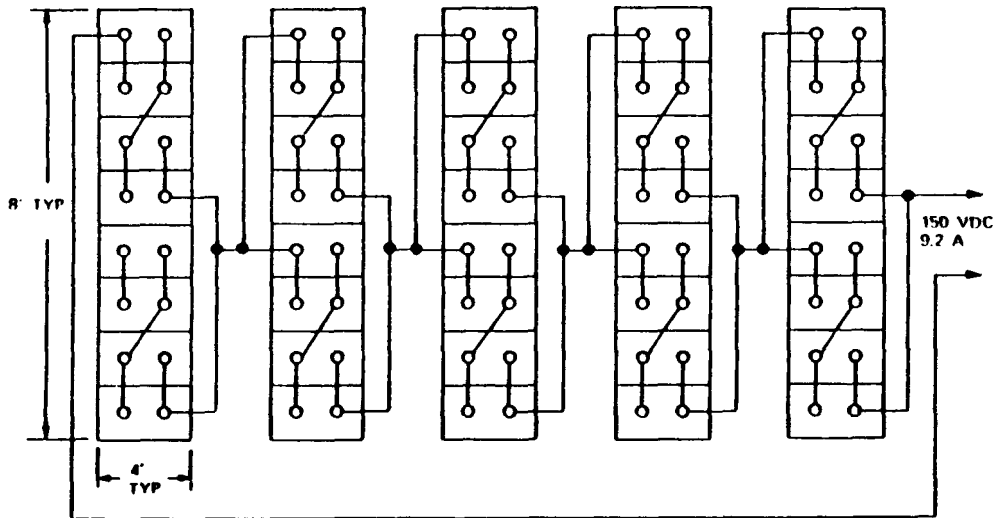

EACH PANEL CONTAINS 2 - 30 VDC, 4.6 AMP MODULE SETS
 CONNECTED IN PARALLEL TO FORM A 30 VOLT 9.2 AMP PANEL.
 5 IDENTICAL PANELS CONNECTED IN SERIES RESULTS IN AN
 ARRAY OF 150 VDC AT 9.2 AMPS - 1380 WATTS

APPROXIMATE WIRE LENGTH - 94 FEET

NOTE: ACTUAL WIRE LENGTH WILL DEPEND ON MODULE WIRE
 TERMINATION.

CONFIGURATION "A"
 FIGURE 3.4-1

PANELS CONSISTING OF 8 1' X 4' MODULES 15 VDC EA. AT 2.3 AMPS

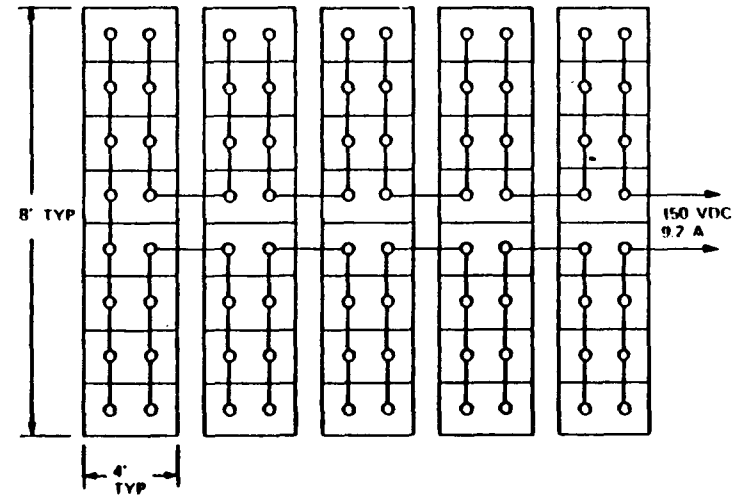

4 MODULES IN PARALLEL, 10 SETS OF 4 MODULES IN SERIES
 FOR 150 VDC AT 9.2 AMPS

APPROXIMATE WIRE LENGTH - 72 FEET

CONFIGURATION "B"
 FIGURE 3.4-2

PANELS CONSISTING OF 8 - 1' X 4' MODULES 15 VDC EA. AT 2.3 AMPS

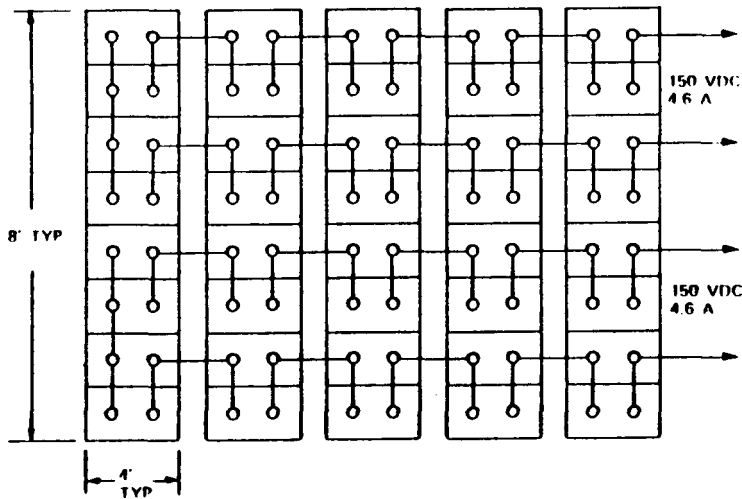

2 MODULES IN PARALLEL, 10 SETS OF 2 PARALLEL MODULES IN SERIES FORM A 150 VOLT 4.6 AMP STRING. 2 STRINGS IN PARALLEL RESULTS IN 150 VOLTS AT 9.2 AMPS

APPROXIMATE WIRE LENGTH - 66 FEET

CONFIGURATION "C"
FIGURE 3.4-3

PANELS CONSISTING OF 8 - 1' X 4' MODULES 15 VDC EA. AT 2.3 AMPS

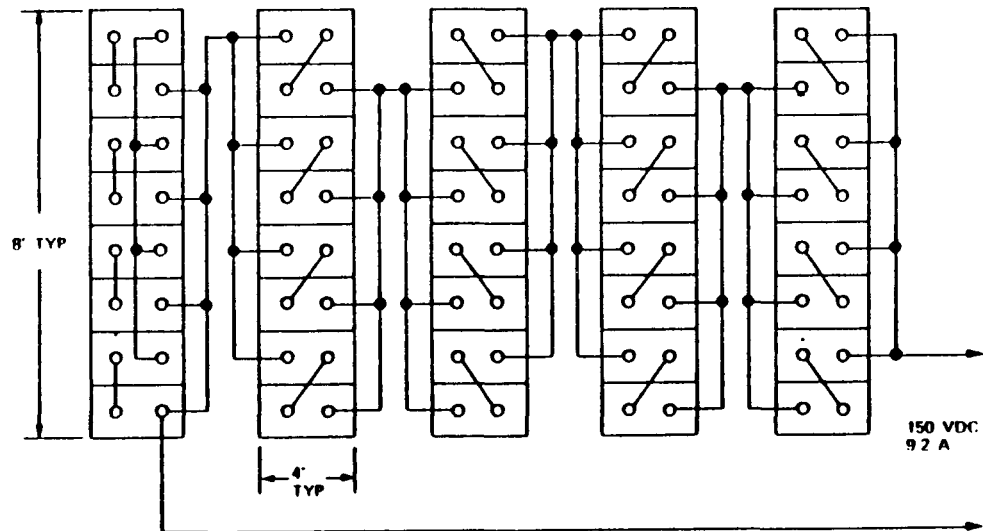

4 SETS OF 2 SERIES MODULES CONNECTED IN PARALLEL FORMS 1 - 30 VOLT 9.2 AMP PANEL. 5 PANELS IN SERIES FORMS A 150 VOLT 9.2 AMP BRANCH.

APPROXIMATE WIRE LENGTH - 151 FEET

CONFIGURATION "D"
FIGURE 3.4-4

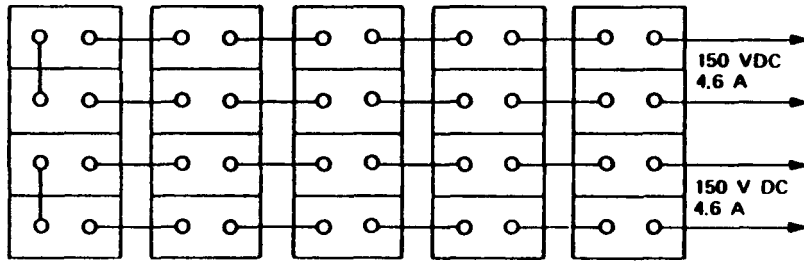

1 2' X 4' MODULE PRODUCES 15 VDC AT 4.6 ADC (70 WP)
 10 MODULES IN SERIES PRODUCE 150 VDC AT 4.6 ADC

CONFIGURATION "E"
 FIGURE 3.4-5

PANELS CONSISTING OF 8 - 1' X 4' MODULES 15 VDC EA. AT 2.3 AMPS

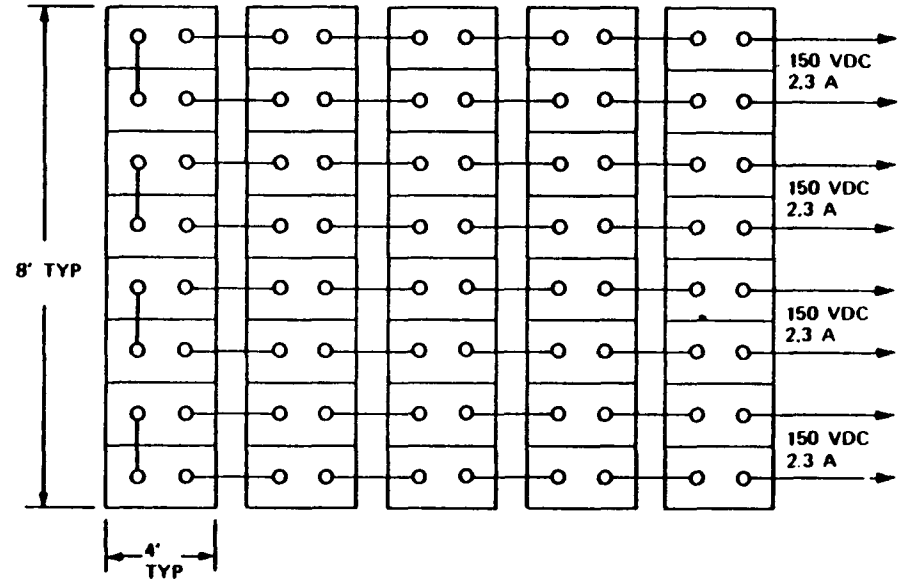

10 - 15 VOLT MODULES IN SERIES FOR 150 VDC AT 2.3 AMP
 OUTPUTS CAN BE ARRANGED IN A MONOPOLAR CONFIGURATION
 OF 150 VOLTS AT 9.2 AMPS UP TO 600 VOLTS AT 4.6 AMPS
 OR A BIPOLAR CONFIGURATION OF \pm 150 VOLTS AT 4.6 AMPS TO
 \pm 300 VOLTS AT 2.3 AMPS.

APPROXIMATE WIRE LENGTH = 48 FEET

NOTE: WIRE LENGTH WILL VARY DEPENDING ON MODULE WIRE
 TERMINATION.

CONFIGURATION "F"
 FIGURE 3.4-6

3.4.3.1 Tapered Ampacity Bus

A representative power collection tree is depicted in Figure 3.4-7.

A series module string of ten generates 4.26 ADC @ 150 VDC. For this configuration, from four to perhaps twelve of these basic blocks can be summed in a field J-Box mounted on or near the array structure. For larger fields it would be cost effective to sum again in secondary J Boxes, depicted as J Boxes "B" in the sketch. Similarly, for fields above 100 kWp, a summing node at J Box "C" might be included.

Cable cost per unit length is approximately proportional to conductor cross-section and thus copper weight. When summing photovoltaic currents, each successively larger conductor must maintain the same inverse ratio of current to specific resistivity as the smaller contributing branches. Bus ampacity tapering does not appear to suffer a disproportionate wire size/cost penalty; for these lower system ratings, the cost of the additional J-Boxes, interconnect hardware and the installation labor, plus some loss of quantity discounts appears to outweigh any advantages obtained from reducing the number of long runs of smaller wire.

3.4.3.2 Loop Power Collection

Loop Power Collection is the complement of the loop power distribution. The latter is used extensively by electrical utilities. A representative loop system is depicted in Figure 3.4-8. In this example, the several dispersed sources could typically be photovoltaic array sub-fields; possibly the power output of a compatible wind-turbine might be fed into the loop.

This methodology becomes dominant where the power sources are highly dispersed and irregularly sited. It is also inherently redundant; for example, a break in the main feeder at point "X" will not interrupt power. With regard to distance factors, the physical configuration may be such that it would be more economical to cable from A to D than to run separate feeders from central to both dispersed sources. For compact stand-alone systems, the loop approach appears to be an impractical choice.

3.4.3.3 The Radial Topology

The topology of the radial power collection field is depicted in Figure 3.4-9. Power from the contributing branch circuits is routed by a dedicated cable back to the power controller. The configuration depicted is that of a 6 Power Unit installation.

Series connections of the end modules (or panels) will provide the final connections for power collection. In the radial approach, these interfaces simply become an extension of the electrical loop forming the string or branch. No field J Boxes are thus required; all summing terminations are made in power central. The radial approach is especially attractive for the smaller stand alone systems. For example, a 2 PU system requires 40 ea 2 ft. x 4 ft. modules symmetrically arranged in 10 panel (4 modules per panel) array. Using folded horizontal daisy chains, all branch circuits originate and terminate in the center of the field, between the 5th and 6th panels. A short run only is required, perhaps 6 ft. - 8 ft, to a power controller installed on a rear strut.

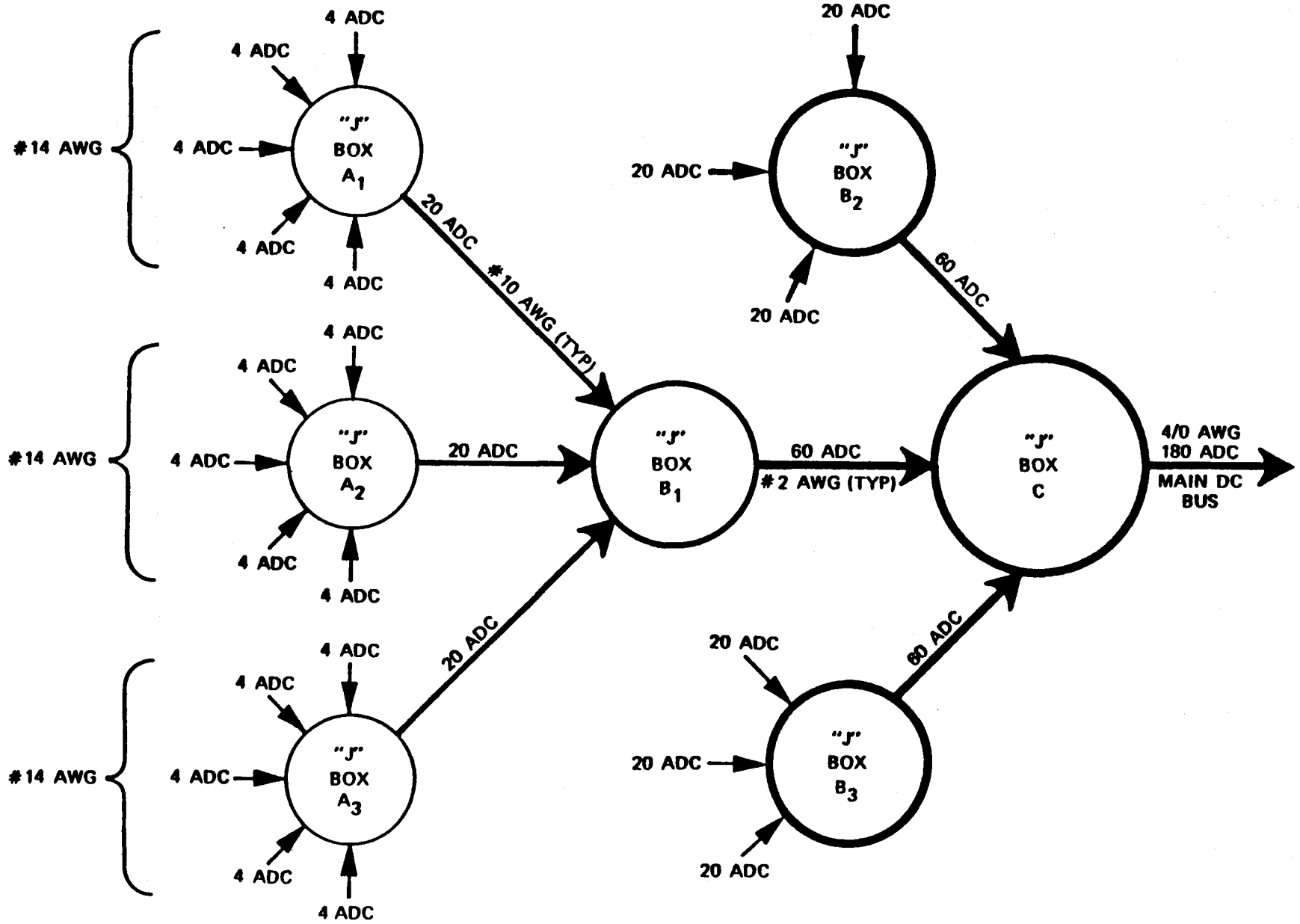

Figure 3.4-7 ARRAY FIELD WIRING: TAPERED AMPACITY BUS.

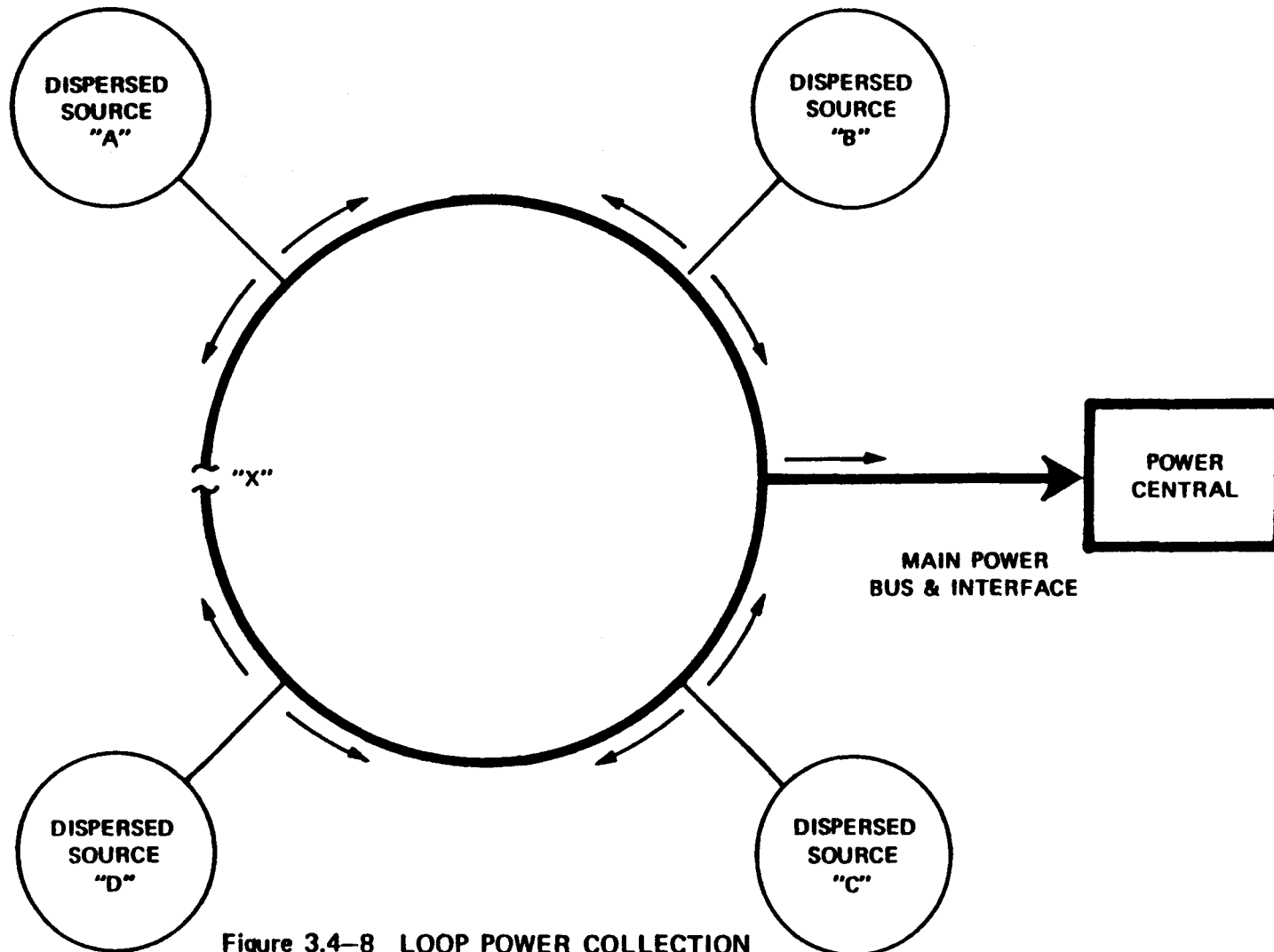

Figure 3.4-8 LOOP POWER COLLECTION

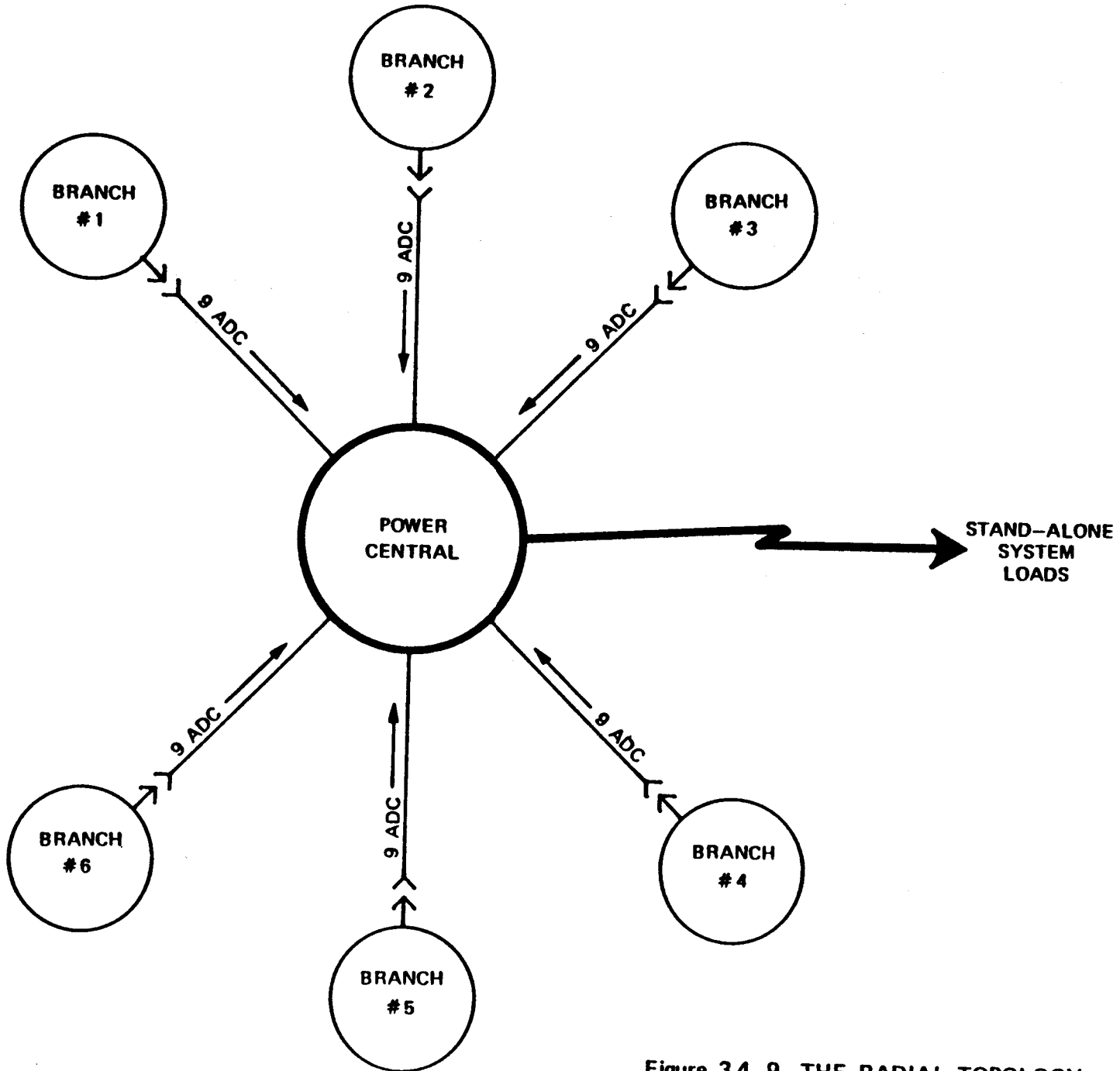

Figure 3.4-9 THE RADIAL TOPOLOGY

3.4.4 Power Cabling Installation

The panel and the array field wiring topologies were examined in light of the following alternative installation methods:

- A. Combined "under-the-panel" and direct burial underground runs of RHW, or PT-N, PT-NN, THHN, THNN aerial/burial cable.
- B. "Under/behind-the-panel" runs only, i.e., no cable burial involved.
- C. Group-to-group or row-to-row routing in surface or shallow subsurface duct or conduit.

The following conclusions were drawn:

- o For systems to 4-6 PU, the center based horizontal daisy chain requires only "under/behind" the panel runs.
- o For 6 - 15 PU, or systems laid out in two rows, relatively short interrow cabling is required. This is most economically done in direct burial cable.
- o Any specific cable types additionally designated "UF" and "USE" by Underwriter's Laboratory (UL Green Book--Electrical Construction Materials Directory.) is acceptable for direct burial. This method, with approved transitions and installations, is recommended.
- o Further protection of the conductors by encasement in underground conduit is not necessary. In rodent infested areas, special precautions may be wise per U.S. electrical utility practices. Schedule 80 PVC is the only nonmetallic type approved for combined overhead and underground use. Several conduit types are approved for underground use, including fiber, asbestos cement, and high density polyethylene. Rigid metallic conduit and IMC are also approved for both uses.

3.4.5 Summary Cost Data

Materials costs were estimated for the six panel wiring topologies using a 1 kWp (1 PU) baseline system rating and projected yearly procurement levels of 1 MWp. Three array field wiring topologies were previously discussed. In this cost study, both the loop feed and the tapered ampacity bus were not appraised because of considered unsuitability for small, stand-alone systems.

The wire used was the equivalent of type PT-N or PT-NN, based upon a copper price of \$0.90 per pound. In multiconductor cable, each wire had PVC insulation with a nylon sheath. The individual conductors were protected with an overall PVC sheath. The sheath was neoprene on the PT-NN cable.

The cost of PT-N type wire is as follows:

<u>Wire Size</u>	<u>Cost*</u>
14	\$ 158/ 1 K ft.
12	\$ 206/ 1 K ft.
10	\$ 308/ 1 K ft.
6	\$1,056/ 1 K ft.

*20,000 ft. procurement levels.

Where a single conductor wire was required, type RRXLP, copper conductor coated with cross linked polyethylene insulation, was specified. It is suitable for aerial use and also resistant to moisture, oil, acid, alkali, and sunlight. Solarlok connectors were used to interconnect modules and panels. Table 3.4.5-1 summarizes the comparative cost data.

Examination of the cost data for the six configurations indicated "B", "E" and "F" produced the three lowest comparative costs, with "B" being the lowest and "E" only slightly higher. "B" did not appear to be a particularly attractive system from the maintenance viewpoint because fault isolation difficulty and the need for total system shutdown in the event of module failure. Differential vertical array shading was considered to be more serious in this option. Some form of horizontal daisy chain was clearly indicated as the preferred functional, as well as cost effective, choice.

TABLE 3.4.5-1. SUMMARY COST DATA FOR 6 PANEL WIRING TOPOLOGIES

CONFIGURATION	SUMMARY DESCRIPTION	COST FOR 1 KWP INSTALLATION *
"A" (Fig. 3.4-1)	Series connected 30 volts panels (8 ea. 1 ft. x 4 ft. modules per panel)	\$347.45
"B" (Fig. 3.4-2)	Horizontal folded daisy chain of 4 module/ 1/2 panels	\$119.00
"C" (Fig. 3.4-3)	Horizontal daisy chain of 2 folded, double rows of 1 ft. x 4 ft. modules	\$337.90
"D" (Fig. 3.4-4)	Series connected blocks of 30 volt panels	\$224.20
"E" (Fig. 3.4-5)	Horizontal daisy chain of 2 folded single rows of 2 ft. x 4 ft. modules	\$123.80
"F" (Fig. 3.4-6)	Horizontal daisy chain of 4 folded rows of 1 ft. x 4 ft. modules	\$175.00

* Including Solarlok connectors and based upon copper at \$0.90/lb x 20,000 ft. procurement.

3.5 Power Conditioning and Control

3.5.1 General

This essential function in stand-alone systems is accomplished by a major BOS element, the Power Controller. This subsystem includes:

- o A battery charge regulator.
- o Protective circuits and switchgear.
- o Status and abnormal events displays.
- o Load management functions.
- o Power controls.
- o Main DC bus and power interfaces.

All of the above, in varying degrees, shape the system longevity and operability. Alternative approaches, including their estimated leverage on life-cycle costs, are summarized for each attribute in the following paragraphs. An optimum solution in this BOS area requires principally mature circuit design, proper consideration of battery vulnerability, and the judicious selection and application of electrical power components.

3.5.2 Battery Charge Control

3.5.2.1 Requirements

The photovoltaic array behaves as a constant current generator, and the battery behaves as a quasi-constant voltage load, with the desired voltage being temperature dependent. Excessive charging voltage shortens battery life, while lower voltage causes the stored energy reserve to be less than the batteries capability. In most well designed flat plate stand-alone systems, the batteries do not reach full charge during most of the year. During favorable periods in the annual and diurnal cycle, the batteries will reach full charge and should be maintained "on-float" after balancing the load demand. Acceptable charge regulation designs must therefore:

- o Sense and respond to battery terminal voltage.
- o Adjust float voltage for cell temperature.
- o Maximize array energy delivery during periods of battery depletion.
- o Ensure that battery is maintained at full-charge, consistent with assurance of maximum battery longevity.

Major variables shaping the selection of control approaches are: a) the quantity, type, operational ratings and cost of devices for control of charging current, and the b) thermal apparatus (if any) required to absorb the resulting heat. Minor variables include the signal conditioners, sensors, ancillary protective circuits and the central wiring.

3.5.2.2 Regulator Design Alternatives

A PV battery charge regulator is characterized by specific combinations of:

- o The method of feedback control.
- o The power switching/metering element.
- o The means of surplus power rejection.

Some of the alternatives include solid state versus electromechanical switchers, linear or OFF-ON, and various schemes of partitioning the array power elements. Out of necessity, a large number of combinations and potential alternatives were first reduced to eight realistic candidate circuits. The block diagrams of these eight configurations are given in Figures 3.5-1 through 3.5-8 following. Each particular approach is briefly analyzed in the paragraphs following.

3.5.3 The Linear Series Regulator

The series control is portrayed in simplified form in Figure 3.5-1. Both temperature, T, and voltage, V, of the battery are sensed and used to control a power transistor, Q₁, which is in series between the array and the battery.

The saturation voltage drop in the transistor, V_{cesat}, is:

$$V_{cesat} = 1 \text{ volt}$$

Thus, power loss P_D is:

$$P_D = V_{cesat} \times I_c = 1 \text{ watt per ampere of collector current (Ic).}$$

The array must be sized to accomodate this steady state loss.

When the battery voltage and temperature indicate that no further charging is required, the control increases the voltage drop across the transistor, V_{ce}, until the array current equals the load current:

$$V_{ce} = V_{array} - V_{float}$$

and

$$P_d = (V_{array} - V_{float}) I_c$$

The difference between V_{array} and V_{float} can be appreciable, up to 25 percent of the normally open array voltage. The current to maintain a typical float voltage in a lead-acid battery can typically be as much as 20 percent of the available array current. Under these conditions, the power, P_D, dissipated in the pass element would be 5 percent of the array power.

This was a major cost element of the series control. The cost of the transistor and the necessary heat sink were significant. For the NASA LeRC designs, this amounted to about 64 watts per P.U. (1 P.U. = 1.28 KW).

Despite these drawbacks, the series control possesses two significant advantages:

- o Heating of the battery electrolyte was kept to the minimum possible for a given load cycle. This favorably affects battery life.
- o The stored energy was maximized because when battery discharge resumes (with decreasing insolation), the battery starts from a fully charged state. Because there is no hysteresis in the control, discharge always begins from the optimum.

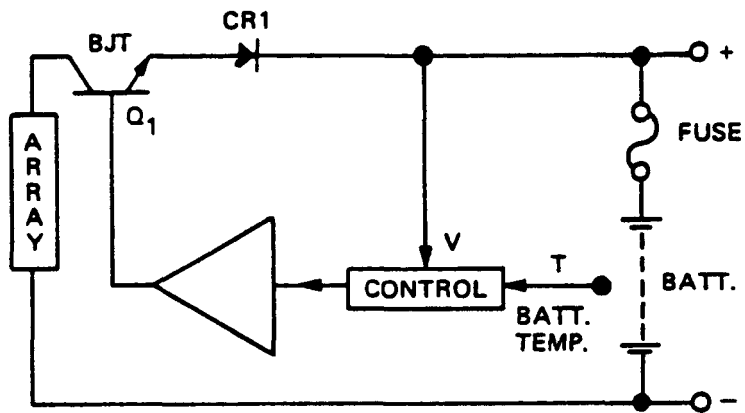

FIGURE 3.5-1 SERIES LINEAR BJT CONTROL

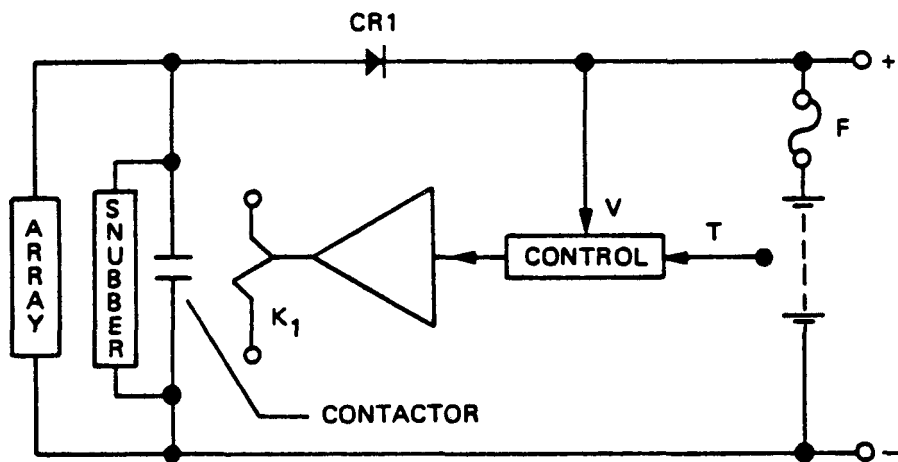

FIGURE 3.5-2 ON-OFF SHUNT CONTACTOR CONTROL

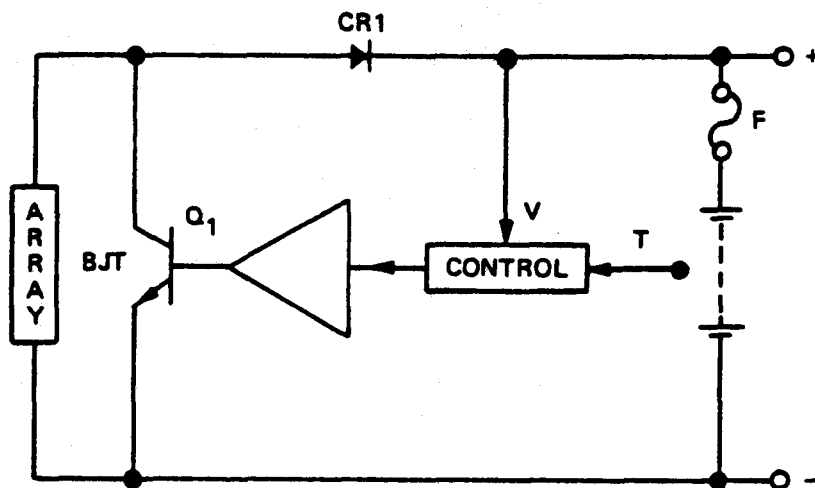

FIGURE 3.5-3 ON-OFF SHUNT BJT CONTROL

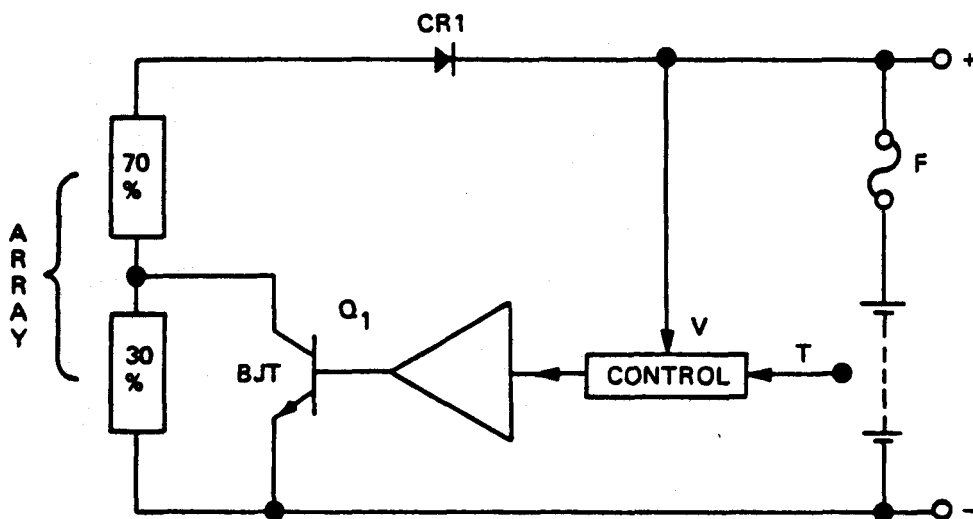

FIGURE 3.5-4 ON-OFF SHUNT BJT CONTROL (TAPPED)

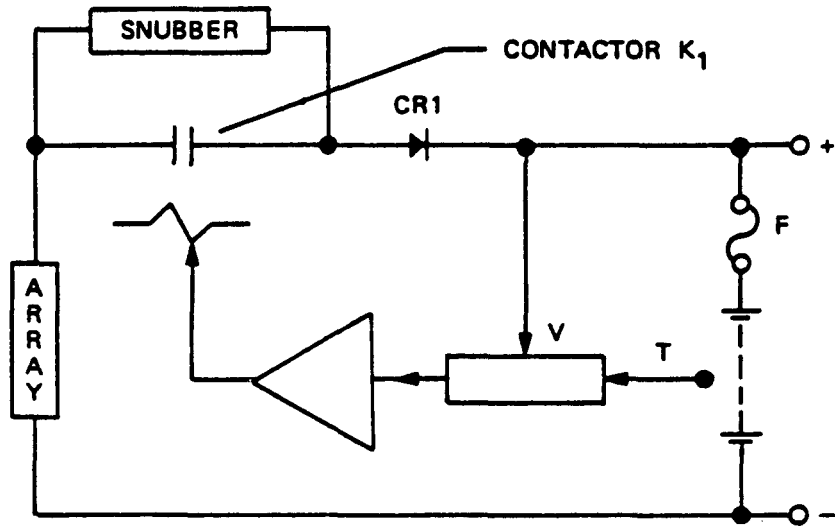

FIGURE 3.5-5 ON-OFF SERIES CONTACTOR CONTROL

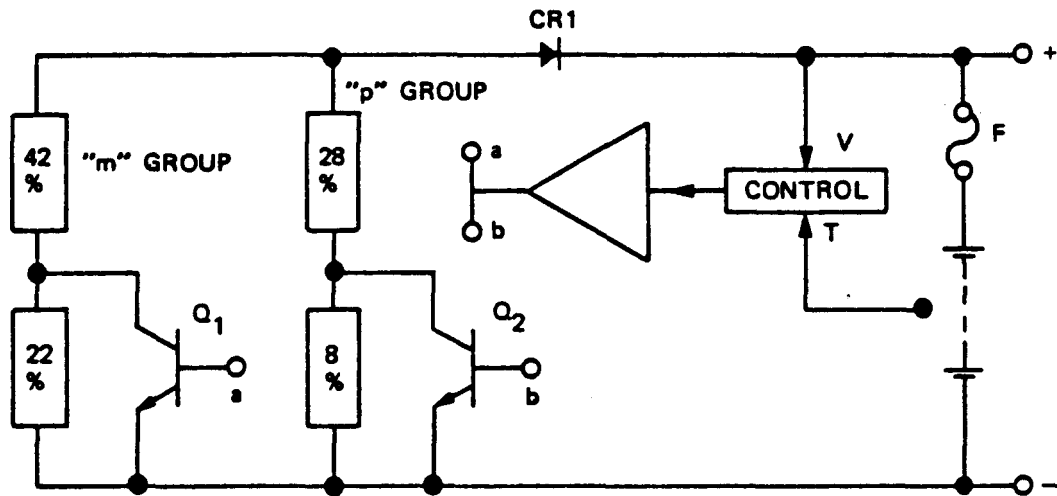

FIGURE 3.5-6 TRI-STATE CONTROL

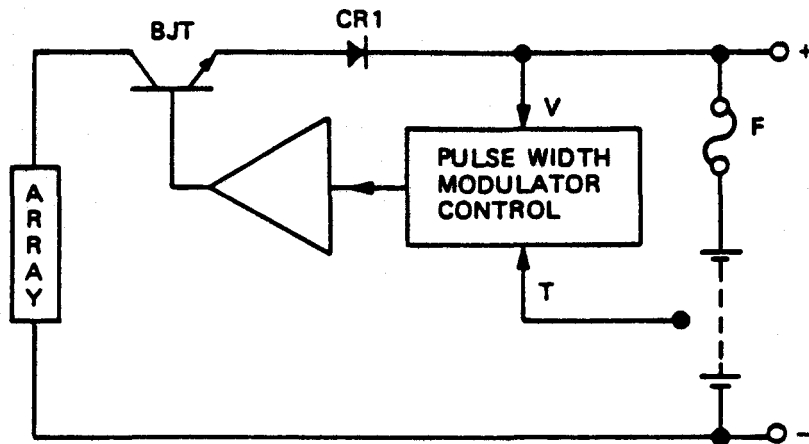

FIGURE 3.5-7 PULSE WIDTH MODULATOR SERIES CONTROL

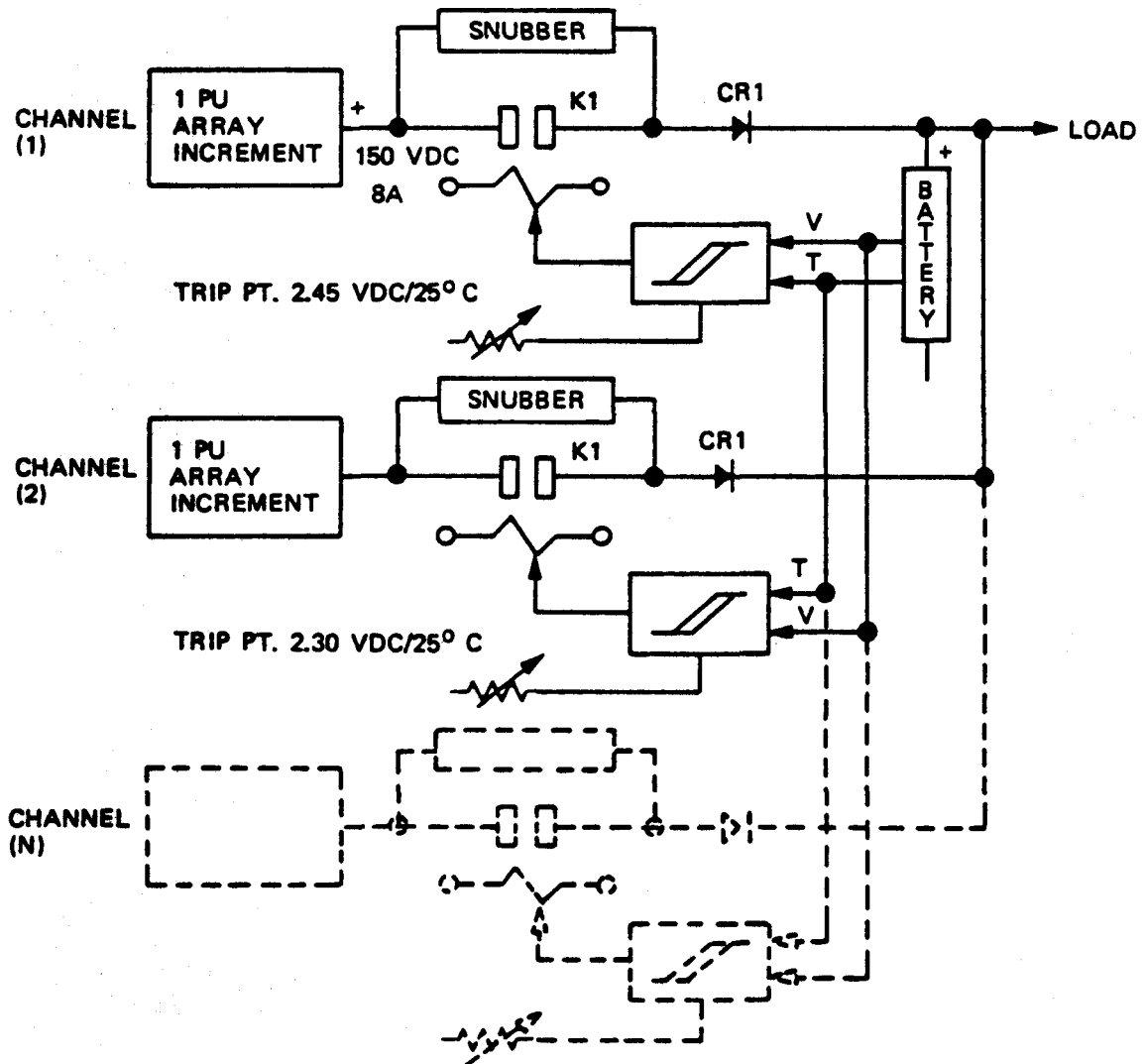

FIGURE 3.5-8 BATTERY CHARGER REGULATOR MULTI-LEVEL SERIES (OFF-ON)

A final factor tends to be self-defeating. The absence of mechanical components such as contactors may improve reliability; however, the high power dissipation required either very skilled technicians to replace a transistor or throw-away spares in which heat sink and transistor are replaced as a unit.

3.5.4 Shunt Regulator (ON-OFF Type)

The on-off shunt regulator is depicted in Figures 3.5-2 and 3.5-3, using either a contactor or a solid state switch as the switching element. When the batteries reach float voltage, the contactor/or static switch closes, shorting out the array. The blocking diode CR1 prevents battery discharge; load current is drawn exclusively from the battery. When the battery voltage has declined sufficiently below float voltage, the control opens the contactor/static switch, allowing the array to charge the battery. Because the array current is normally several times larger than the load current, float voltage would again be reached and the process repeated. Hysteresis is implicit in any on-off control. The ON-OFF cycling proceeds until declining insolation causes the array current to fall below load current.

There are evident advantages to the shunt system:

- o Simplicity in operation and maintenance.
- o Minimal losses during charging.

A variant of the "OFF-ON" shunt BJT regulator is given in Figure 3.5-4. It is the tapped version wherein only a fraction of the array is shorted out by the regulating shunt switch. Switching stress on the array as well as on the switching elements is reduced.

All versions of the OFF-ON shunt regulators have the disadvantage that the battery may often begin its diurnal discharge from a less-than-fully-charged state. However, when sufficient insolation is available, it is not cumulative from day-to-day. The battery is also cycled during the float period, increasing electrolyte heating and disassociation. Float cycling does serve as a topping charge, forcing the battery towards 100 percent charge replenishment. The solid state versions have no inherent sense-input-to-control output isolation, thus increasing possible transient susceptibility. Rapid cycling may shorten the operating life of the contactors in that version. Hermetically sealed contactors with exceptionally high MCBFs (mean-cycles-to-failure) are available; for example a mercury displacement device has a MCBF in excess of four million cycles. Using suitable snubbers additionally increases the power interruption survivability to that of the mechanical cycle life.

3.5.5 PWM (Pulse-Width Modulated) Shunt Regulator

The PWM shunt regulator is a true duty cycle modulated proportional controller. Its simplified schematic is that of Figure 3.5-7, with the control element being a voltage controlled pulse width modulator instead of the comparator shown on the schematic.

The PWM shunt control appeared to have only one advantage: the battery begins its diurnal discharge cycle from a near-fully charged state. However, this advantage may not be as great as first appears. It was noted for the shunt control that this shortfall was not cumulative. During the float season, a

shortfall one day would simply mean the battery reached float a little later the following day, thus canceling the cumulative effect. Only that shortfall of the final day of the float season subtracts from the year's cumulative energy. This is a small effect.

The PWM control has several disadvantages:

- o It produces more heating of the battery electrolyte than any other system.
- o The pulse width modulator control of a large array might radiate significant EMI.

On balance, the PWM method is felt to be a weak competitor.

3.5.6 OFF-ON Series, Regulator (Electromechanical)

The OFF-ON series EM regulator is depicted in Figure 3.5-5. A DC contactor (protected by a snubber) is used as the switching element. When the batteries reach float voltage, the contactor opens, disconnecting the array. As in the other configurations, the blocking diode CR1 prevents battery discharge back into the array. When the contactor is "open," the load is drawn exclusively from the battery. When the battery voltage has declined below float voltage, to a reset point determined by the hysteresis, the control closes the contactor, allowing the array to charge the battery. Because the array current might normally be several times the load current, float voltage would again be reached and the process repeated. Hysteresis prevents unnecessarily rapid cycling of the feedback loop and allows any switching transients to subside safely after a state change. OFF-ON cycling continues until declining isolation causes the array current to fall below load current. With a representative hysteresis setting, a 1.5 kW peak array float charging a 640 AH battery string typically cycles at rates of 1 cycle per 5 minutes when batteries are near full charge, and the load demand is about 20 percent of equivalent array current. With increasing loads, discharged batteries, and decreasing isolation, the array "ON" period increases proportionally, at times approaching 100 percent.

The series contactor OFF-ON system had several advantages.

- o Heat ejection requirements are virtually non-existent.
- o Using relay drivers, heat sinks are not required.
- o Isolation of the control loop from the power bus is complete.
- o The snubbers permit the reliable use of industrial relays and low voltage AC distribution switchgear.
- o Series insertion losses due to contact resistance are minimal (0.01 percent); is far superior to the solid state switches (5 percent)
- o Maintainability (minimum down time) appeared to be excellent.
- o The contactor can also serve as an automatic over-voltage safety disconnect; also it can be opened by a manual override.
- o Hermetically sealed mercury displacement contactors (of suitable rating) with MCBF of 4×10^6 cycles are readily available.

There are several disadvantages common to all OFF-ON controls:

- o The battery is cycled during the float period, increasing electrolyte heating over that present in proportional control; battery manufacturers have, indicated, however this float cycling may assist in 100 percent charge replenishment.
- o The battery could often begin its discharge from a less-than-fully-charged state. This is not, however, be cumulative from day-to-day.
- o The optimal hysteresis setting may turn out to be a compromise between transient immunity and delayed response, with the latter leading to a minor energy loss.

3.5.7 Tri-State Control

Figure 3.5-6 depicts the tri-state control, which has the advantages of both the shunt and series control, without some of the attendant disadvantages of either. In tristate control the series array branches are partitioned into two groups as depicted in the block diagram. Two control algorithms, separately mechanized, are used. The higher output "m" group is controlled by a tapped shunt regulator; the smaller "p" group is a proportional control that operates only when the "m" group was disconnected. This latter "vernier" control mechanizes the actual V_{float} algorithm. This combination of three charging states flexibly accomodates various load demands, varying array outputs and battery charge states over the annual operating profile.

The multistate configuration has certain advantages over single state regulators:

- o Battery current is reduced to the minimum level consistent with load. Battery heating is reduced, and battery life is extended both from thermal and cyclic considerations.
- o The costs of the regulating element in the proportional control and its heat sink are substantially reduced.
- o Losses in the proportional control unit during connected operation are reduced to the degree that a power transistor becomes feasible for this element.

The disadvantages of the tri-state control are:

- o Multiple bipolar transistors in heat sinks increase circuit complexity as compared with single, higher current electromechanical devices.
- o While the controls may not be unreasonably complex, mechanization of even the lowest modular power level required a number of independent functions.
- o Safety isolation is not optimal; additional protective devices could be required.

3.5.8 Series PWM Switching Regulator

Two problems are involved with the switching regulator between a photovoltaic array and a battery as shown in Figure 3.5-7. A typical squarewave switching or chopper frequency of 10 kHz was assumed.

- 1) Proper operation of the switcher requires that while the pass transistor is on, operation has to be to the right of the knee of the I-vs-V curve of the array:

- o to maintain duty cycle well removed from 100 percent, and
 - o to avoid the constant currents area which are not in the switcher's control algorithm.
- 2) The battery is a larger capacitor (effectively) than any capacitor that could be placed in the circuit. Thus, almost all of the ripple current passes through the battery, heating the electrolyte. To prolong battery life, it would be necessary to disconnect the battery during float operation or possibly isolate it with a large inductor.

The inherent weakness of the series PWM switching regulator to removes this concept from further consideration.

3.5.9 Multilevel Series Control (OFF-ON Description)

This control scheme, a variation of the series OFF/ON regulator, and the Tri-State control are depicted in Figure 3.5-8. Tri-state control features leading to improved battery life are retained without the attendant complexity of two different control modes.

The performance of each channel is identical to that of the single channel series contactor system except that the trip float voltage limits are set at slightly different values for each of the two channels.

The 2.45 VPC maximum (volts per cell) at 25°C is typically recommended by the manufacturer as a float voltage for the 1300 specific gravity lead calcium cells. Channel (1) typically controlling 50 percent of the array power is set to trip at, 2.5 VPC. Channel (2) is set to trip at a slightly lower value, about 2.45 VPC. At some point in the recharge cycle, the 2.45 VPC Channel 2 limit would be reached. For a 150 volts, 1 power unit system nominal charging current would be about nine amperes. An OFF-TRIP of Channel 2 would therefore result in a 50 percent charge current reduction. The final charge regime on the battery has now been tapered to about 4.5 amperes. When the cell potential reaches 2.50 VPC @ 25 C, the Channel 1 regulator OFF-TRIPS, terminating charging current completely.

As the battery discharges, the first trip point reached would be 2.45 VPC. Charging resumes; the battery potential would continue to decline if a net negative energy balance (Power out > Power in) existed. When the 2.35 VPC level is reached, the other contributing subarray would be connected. Thereinafter, the cycle is repeated.

The advantages of multilevel OFF-ON series control are:

- (a) As in the case of the Hughes tri-state design, the charging current is reduced to a minimum rate consistent with load and PV power input. Battery heating is reduced, and battery life should be extended from both cyclic and thermal considerations.
- (b) Only a small heat sink is required for the string blocking diodes (800mW/amp); no cabinet ventilation is required.
- (c) Multilevel regulation requires only replication of the standard EM (electromechanical) OFF-ON control and partitioning of parallel array elements.

- (d) Quasi-proportional control is approached if the number of array power increments and steps are increased, and additional control channels are employed.
- (e) This method is also compatible with summing and regulating the outputs of hybrid Renewable Energy System sources on a battery bus. This cannot be done with shunt regulation.
- (f) Overvoltage protection, manual override and shutdown can be done with the same multilevel control contactors.

3.5.10 On-Going Task I (Subtask B) Analysis

At the conclusion of Task I, Subtask B, six candidate configurations were still being actively considered:

<u>CONTROL METHOD</u>		
<u>Control Type</u>	<u>ON-OFF</u>	<u>Proportional</u>
1. Shunt Contactor	x	
2. Shunt Transistor	x	
3. Shunt Transistor (tapped array)	x	
4. Tri-State Control		x
5. Series Contactor (EM)	x	
6. Multilevel Series EM Control		x

The series proportional Bipolar Junction Transistor (BJT) method was no longer considered to be a viable candidate because of excessive heat rejection requirements. The same comment applies to a linear shunt BJT configuration. Voltage controlled pulse width modulators were rejected for reasons of complexity, battery stress and potential EMI interference. None of the surviving methods impacted unfavorably upon the other BOS systems, and all candidates could be modularly expanded with ease.

Accordingly, the work in Task IB was concentrated upon the areas where differences did appear:

- o Battery charging stress
- o Direct capital cost
- o Maintenance requirements
- o Anticipated environmental performance
- o World-wide adaptability
- o Lifetime cost effectiveness

The control schemes divide into two classes on the matter of battery charging stress. The proportional controls provide the minimum possible stress, while the ON-OFF controls result in more stress. To be acceptable, any regulator must embody temperature compensation in its control algorithm. This is a major factor in a) avoiding battery overcharging and probable destruction and b) ensuring cost effective battery selection and utilization by ensuring complete recharging over the temperature range.

3.5.11 Ranking for Use in Conceptual Designs

Recommendations and ranking of the most promising charging circuits for formation of the conceptual designs are given in terms of comparison of candidate configurations for a selected performance parameter of interest. These parameters are:

- o Modular and incremental levels.
- o Module heat ejection requirements.
- o Environmental stress factors.
- o Reliability and maintainability factors.
- o Adaptability to world-wide installations.
- o Initial cost estimates.

3.5.11.1 Modular Power Levels

The modular power levels for the candidate controls were dictated by manufacturer's prices for the current controlling elements. Models of BJTs (Bipolar Junction Transistors), DTs (Darlington Transistors) revealed a pronounced minimum in \$/ampere in the voltage range of 100 - 200 volts. For example, an 8 ampere transistor (mounting hardware included) was cheaper than two 3 ampere transistors; and three 8 ampere transistors were about 1/2 the cost of one 20 ampere transistor. Perhaps more significant was the broad range of voltage ratings available from DTs, from 100 to over 500 volts at a nearly constant price:

\$1.50 per short-circuit kW

The short-circuit kW was defined as open-circuit voltage times short-circuit current. Thus, a basic increment, from a cost standpoint, was:

18 volts x 8 amp = 1.44 kW (Short-Circuit)

Considering 1 kW power for those schemes controlling the entire array voltage, the following was shown for the solid state devices installed in a heat sink:

	<u>Basic Increment</u>	<u>Cost in \$/Short-Circuit kW</u>
Series Transistor	1 kW pk	\$11.00
Shunt Transistor	1 kW pk	\$11.00

The modular power for the remaining configurations depended upon the price of DC contactors suitable for repetitively interrupting 10-30 ADC @ 160 VDC over the lifetime of the stand-alone system. Several candidate devices were evaluated. With appropriate external snubbers, all of the hermetically sealed devices would be acceptable in their standard configuration; the PRD \$/SCkW are estimated with the assumption that they would be installed in a sealed case. Table 3.5.11-1 summarizes our findings on hermetic relays.

The preceding table applies to both the shunt and series contactor configurations, as well as to individual channels of the multilevel EM Regulator. It is apparent that the cost of a suitable hermetically sealed contactor is comparable to that of the BJT or DT switches when the costs of heat sinks for the latter are included.

Table 3.5.11-1. Comparison of Candidate Hermetic Relays

^Mfr. and Type^	^Description^	^Coil Data^	^Close & Open Type^	^Contact Info^	^Cost^	^Open Circuit Withstand^	^Equivalent Short Circuit Increment^	^\$/SC- kw^
Magnecraft WM35A-24D	Hg Hermetic SPST (N.O.)	N.O. Pwr = 6.5W 24V @ 270 ma	50 msec to close 80 msec to open	35 amp carry Break 18A @ 120 VDC, 12A @ 240 VDC	20.60	2650V R.M.S. for 1 second U.L. Spec.	2.2 Kw	\$9.36
NOTE: Contact is mercury to metal								
Durakool BF 7046	Hg Hermetic SPST (N.O.)	Pwr = 2.7W 24V @ 110 ma	80 msec to close 120 msec to open	30 amp carry Break 25A @ 125 VDC, 15A @ 240 VDC	24.79	5000V R.M.S. can terminal to Gnd, 5000V R.M.S. Ter to Ter	3.1 Kw	\$8.00
NOTE: Contact is mercury to metal								
Potter & Brumfield PRD 7DJ024V	Displacement DPDT with Magnetic Blowout	Pwr = 2W 24 VDC @ 84 ma	25 msec to close 25 msec to open	30 amp carry Break 20 @ 125 VDC, 12 @ 240 VDC	15.55	2000V R.M.S.	2.5 Kw	\$6.22
NOTE: Reduced Contact Life without Snubbers @ 240 VDC								
Leach Relay #7064-5653	Displacement SPST N.O.	Pwr = 7.85W 28V @ 280 ma	20 msec to close 10 msec to open	50 amp carry Break 2.5 amps @ 125VDC (w/o snubbers & w/double break)	98.00	1250V R.M.S.	4.0 Kw	\$25.00

NOTE: Struthers-Dunn & Magnecraft have relays similar to the Potter & Brumfield PRD 7DJ024V at competitive prices.

3.5.11.2 Module Heat Ejection Requirements

The heat ejection requirements for the candidate schemes were analyzed in Task I, subtask B. A wide variation among the candidate controls was evidenced. To establish a basis for comparison, dissipation was stated in "watts/peak kW." This was a convenient unit in view of the 1 kW increments.

<u>Control Type</u>	<u>Basic Module kW</u>	<u>Increment kW</u>	<u>Thermal Watts/ Peak kW</u>
Shunt Contactor	2	2	1
Shunt Transistor	1	1	10
Shunt Transistor (tap)	1	1	10
Series Contactor	1	1	1
Tri-State Control	4	1	14
Multilevel EM	2	1	1

Contactors schemes resulted in almost an order of magnitude of less heat rejection than the three solid state configurations. As a point of comparison, the series linear BJT regulator previously rejected had an inherent heat rejection problem almost two orders of magnitude worse than the electromechanical devices.

3.5.11.3 Environmental Stress Factors

The intent to deploy the proposed system on a near-world-wide basis extended the range and type of environmental stress factors that had to be considered. Major items included:

- o Maximum operating ambient temperature.
- o Minimum operating ambient temperature.
- o Wind-driven dust and sand.
- o Wind-driven rain.
- o Corrosive precipitation products.
- o Snow burial, ice encapsulation (limited future concern).
- o Salt spray and salt fog.
- o Rodent penetration.

Candidate control types were examined against these environmental factors with the following assumptions:

- o All power contactors and pilot relays are hermetically sealed and of equivalent Mil-spec quality.
- o The power controller cabinet is NEMA-4 or an equivalent sealed enclosure.
- o Printed circuit boards are conformally coated.

On all factors but high temperature, no significant difference was noted between the candidates. The BJT configurations definitely were more vulnerable to sustained high temperature environments than the systems using electromechanical devices.

3.5.11.3 Maintenance Requirements

Several factors of maintenance were identified:

- o Need and extent of preventive maintenance.
- o Skills and tools required for unscheduled maintenance.
- o Time (simplicity) to repair/replace.
- o Frequency of repair/replacement.

Fortunately, the remaining candidate schemes required only simple tools and skills consistent with a low voltage electrician's ability. This simplicity stemmed from the assumption the repair would not be done on site: hence, replacement would be the mode of site maintenance. This assumption was supported by the relatively low cost of the replaceable elements. As an example:

<u>Control</u>	<u>Replaceable Units</u>	<u>Unit Cost</u>	<u>MTRR (Mean Time to Replace)</u>
Shunt Contactor	Contactora	\$25	15 min.
Shunt BJT	BJT & Heat Sink	\$10	15 min.
Shunt BJT (tap)	BJT & Heat Sink	\$10	15 min.
Series Contactor	Contactora	\$25	15 min.
Tri-State Control	BJT & Heat Sink DT & Heat Sink	\$10 \$10	25 min. 25 min.
Multilevel EM Control	Contactora	\$25	15 min.

The key to attaining any of the projected MTRR's would of course be the incorporation of a well-planned sectionalizing strategy and design for ready fault isolation and corrective action.

3.5.11.4 Life Cycle Cost Effectiveness

Table 3.5.11-2 summarizes the comparative ratings of the six candidates for the battery charger/regulator. Both the tapped and untapped BJTs scored well in most categories. Their reliability in sustained high temperature environments is less than optimal; however, a mature design can overcome these shortfalls. For higher rating systems, heat sink complexity becomes an issue. Prospects for down-stream cost reduction appear excellent, and on balance this option offers a good solution. The shunt contactor provides an acceptable low cost solution. The prospects for down-stream cost reduction are not good, and the method results in less than minimal battery stress. Shunt configurations, including both the electromechanical and the solid-state versions, are inherently compatible with constant current sources.

The OFF-ON series contactor is characterized by low initial cost; future cost savings for the power control devices themselves do not appear too promising, but the control and drive electronics do appear to be excellent candidates for cost reduction. Excellent reliability will result if hermetic contactors, especially those of the mercury displacement type, are used. Common to other float cycling methods, both series and shunt, battery stress is not minimal.

The tri-state control ranked high in potential down-stream cost reduction. Battery stress reduction is excellent, common to all quasi-proportional methods. The tristate control is an improvement over the other solid state methods in regard to heat rejection; but considering relative complexity, it does not compare well with the contactor based designs. This disadvantage results from using two different central modes, each with different mechanization.

The multi-level series EM control rated high in all categories. Its heat rejection is excellent, as is its capability for reducing battery charging stress. A twenty year service life goal appears quite achievable by using hermetic mercury displacement contactors with snubbers. Incremental or quasi-proportional charging is attainable without modifying the basic series EM OFF-ON design.

Table 3.5.11-2. Comparative Ratings of Battery Charge Control Candidates

<u>Control</u>	<u>Initial Cost</u>	<u>Battery Stress</u>	<u>Environment</u>	<u>Maintenance</u>	<u>Module Size</u>	<u>Heat Rejection</u>
Shunt Contactor*	Excl.	Good	Good	Excl.	2 kW	nil
Shunt BJT	Good	Good	Poor	Good	1 kW	10 W/kW
Shunt BJT (tap)	Excl.	Good	Poor	Excl.	1 kW	10 W/kW
Series Contactor*	Excl.	Good	Excl.	Excl.	2 kW	nil
Tri-State Control	Good	Excl.	Poor	Excl.	1 kW	14 W/kW
Multilevel EM Control	Excl.	Excl.	Good	Excl.	2 kW	nil

3.5.12 Summary and Initial Recommendation

It was concluded that conceptual designs proceed on two of the candidate control schemes:

- 1) The tapped shunt BJT control, and
- 2) The multilevel series EM control

3.6 Energy Storage

3.6.1 Initial Considerations

It quickly became apparent that the "short-term" solution to stand-alone PV system storage was in using state-of-the-art storage batteries. Several other storage options that appeared potentially compatible with photovoltaic arrays were examined briefly.

Two forms of mechanical energy storage (flywheels and pumped hydrostorage) were evaluated. Both require immediate electrical-to-mechanical conversion to store energy and to subsequently retrieve it for useful work. Hydrostorage requires a reversible DC motor generator to power the pump on the lift cycle, and then generate electrical power on the carry-over cycle, when the potential energy of the water head is reconverted in a hydro-turbine. The energy density of hydrostorage is very low, typically about 14 BTU/ft³ for a 100 foot head, or 0.2 percent of that of a typical battery. Except for large systems, in high rainfall environments with high yearly water flow, run-off or natural reservoirs pumped water did not appear compatible with stand-alone system needs. Hydrostorage can be considered as a product resource in stand-alone usage, to be beneficially pumped and stored during periods when power from solar insolation might otherwise be wasted.

Conventional as well as advanced flywheel designs were likewise reviewed. Conventional flywheels were found to have about the same energy density as a lead acid battery but at greatly increased specific energy storage costs (kilojoules/dollar). Advanced flywheels appeared to have future promise, but no real short-term prospects. The status of advanced flywheels was periodically reassessed during the early program phases without noting any startling improvement.

Hydride storage was not considered practical because of design complexity and the total lack of technological maturity. Both hydrostorage and flywheels might impose startup problems on photovoltaics due to inrush current demands.

3.6.2 Classification of Electrochemical Cells

The search for optimally cost effective energy storage BOS options was therefore limited to reversible electrochemical systems or secondary storage batteries. Options were classified as given below. Ultimately, only devices in Group I were considered in on-going analysis and design.

Group I: "Off-the-shelf":

These batteries were presently available in production quantities in the marketplace; they could be purchased by model or type number. Substantive field performance data were available and requisite to further consideration. Operational histories covering a span of five to twenty years or greater obtainable from the manufacturer was also required.

Group II: Near-term solutions:

These were improved batteries or electrochemical devices not yet released for large scale production. Their design and performance had to be well proven, by pilot or limited production. Deferred availability, typically two years to production status also merited the "near-term" classification. Exide (ESB Corp) had a battery in this class, a refined version of the older Pb-Ca/Pb-Sb hybrid; it did not become available until late in the program and therefore was not considered a viable option.

Group III: Advanced batteries

These were devices (or methods) proven-in-principle in varying degrees, but still in the research and development phase. Ultimate large scale producibility and cost effectiveness also had not yet been proven. Commercial availability of such advanced devices could be five to ten years in the future. The NASA LeRC REDOX cell and the DOE-EXXON ZINC BROMINE system were considered to be in this category.

3.6.2A Operational Criteria

BOS storage elements that could exert beneficial leverage on levelized energy costs (LEC) were identified. An ideal photovoltaic system battery should possess the following characteristics:

- a) Require a minimum capital investment.
- b) Survive a twenty year operational mission without replacement.
- c) Be acceptably insensitive to environmental stress, particularly temperature extreme.
- d) Require minimum or no maintenance.
- e) Have cycle life acceptability independent of depth of discharge.
- f) Have a high turn-around charging efficiency from the viewpoint of energy, rather than coulombic conversion.

Other factors, such as energy density and simplicity of charging method, became important only if such parameters unfavorably impacted on Levelized Energy Costs (LEC). A number of cell types in the several categories were thoroughly investigated. Technical, cost, and O&M parameters were compiled for entry into the FLEX computer program data file for subsequent comparative LEC analysis. Devices surviving to this point evolved from either:

- a) Evaluation as a particularly promising alternative, or
- b) Insufficient adverse data to permit the device to be summarily rejected.

Cause for rejection included:

- a) Unfavorable cost effectiveness (all causes).
- b) Lack of design and production maturity.
- c) Insufficient field performance history.
- d) Incompatibility with stand-alone PV applications.

3.6.3 The Lead-Acid Battery

The lead-acid battery has evolved over about a 120 year period. By a wide margin, it is the lowest cost means of electrochemical energy storage. The lead-acid battery should not be regarded as a completely documented phenomena, though it is better understood and engineered than it was twenty years ago.

At a typical cost of \$150/kWH (in 1981 dollars), lead-acid batteries are virtually the only viable contender for electrical energy storage means in photovoltaic systems. Several specific types initially appeared to be strongly competitive and were recommended for further analysis. Nickel-cadmium batteries have been used in a very few PV systems where high discharge

rate and cold-weather behavior made them more attractive on a comparative cost and performance basis. Consideration of the Jungner (NiCd) Battery did not extend beyond completion of Task I, "Analysis & Evaluation of BOS elements" because of very poor cost effectiveness.

3.6.4 Types of Lead-Acid Batteries

Many types of lead-acid batteries have been developed and are available in the market place. A number of types are acceptable for remote stand-alone service; many more types are totally unacceptable and would have a very low survival probability.

3.6.4 Review of Initial Battery Selection Process

The below listed lead-acid battery types were initially considered as candidates:

- a. C&D Shallow Discharge Batteries DCP, KCP, LCP series for PV applications.
- b. Willard, Wisco Charge Retaining (Pure Lead) Batteries.
- c. Delco Freedom Lead-Calcium Series 2000.
- d. C&D Deep Daily Cycling Pb-Ca Batteries, QP Series for PV applications.
- e. Lead Antimony or Lead Calcium Electromotive Batteries (Fork Lift, Electric Vehicle, with Multicell Packaging and Factory Interconnection); Trojan, C&D, and ESB Typical Suppliers.

The manufacturers of these batteries were asked particularly to quantify the MCBF (mean-charge/discharge-cycles-before failure) of candidate batteries with regard to:

- a. Electrolyte temperature (sustained or average).
- b. Estimated MCBF at various repetitive depths-of-discharge.
- c. Quantitative data on cell's ability to survive to a distribution of deep and shallow discharges over operating lifetime.
- d. Effect of undercharging and overcharging.
- e. Estimated MCBF and/or service life in specific stand-alone PV applications.

The above was in addition to the more standard performance data, such as coulombic efficiency, recommend charge profile, discharge characteristics and the like.

As an example, the expected life of the DELCO 2000 as a function of operating cycles (as provided by the manufacturer) is given in Figure 3.6.4-1. Equivalent information on both shallow and deep discharge C&D battery types are given in Figure 3.6.4-2. Data such as these provided essential inputs into the lifecycle estimation process for various competitive configurations.

Table 3.6.4-1. Types of Lead-Acid Batteries

<u>Battery Type</u>	<u>Comment on PV Service</u>
<u>SLI</u> (starting, lighting, ignition)	<u>Not recommended</u> - typically thin plates with high self discharge and large changes in terminal potential at end of charge. Chiefly developed for automotive use. Thick plate automotive type batteries for RV and trolling service generally fall out of the SLI category.
<u>Electromotive</u> (forklift, traction, golf cart)	<u>Not recommended</u> - rugged, designed for frequent deep discharge with often high self-discharge. May be either Pb-Ca, Pb-Sn, or Hybrid.
<u>Stationary</u> - pure lead - lead-calcium - low (1 percent PbSb) - Shallow Discharge Pb-Ca - Deep Discharge Pb-Ca - Pb-Sb/Pb-Ca Hybrid	Major offerings are in connection with conventional UPS, stand-by, emergency power and related industrial applications. Manufacturers offer special lines of shallow and deep discharge lead calcium and lead antimony batteries specifically for photovoltaic applications. Pure lead batteries are excellent for stand alone service but their high internal impedance prohibits their use when discharge rates are typically greater than C/50 hours. Pb-Sb/Pb-Ca hybrids also will shortly become available.

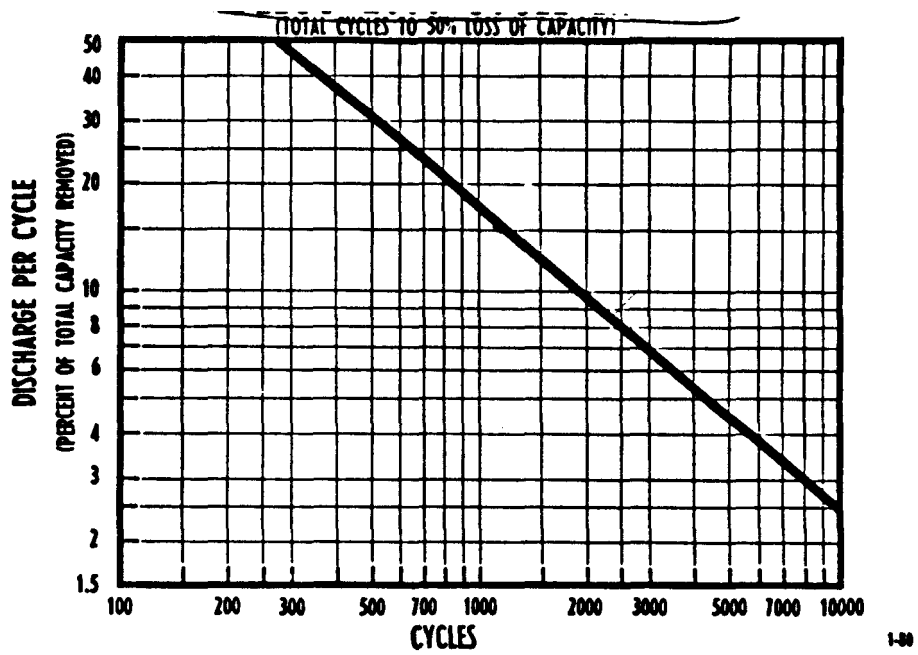

ESTIMATED CYCLE LIFE OF DELCO 2000 BATTERY AS A FUNCTION OF DEPTH-OF-DISCHARGE
 FIGURE 3.6.4-1

C & D BATTERIES
an ELTRA Co.

SERI
TYPICAL
DEPTH-OF-DISCHARGE
VS
CYCLE LIFE
OF
C & D PV CYCLING TYPE BATTERY

APPROVED J/S

DATE 2-6-80

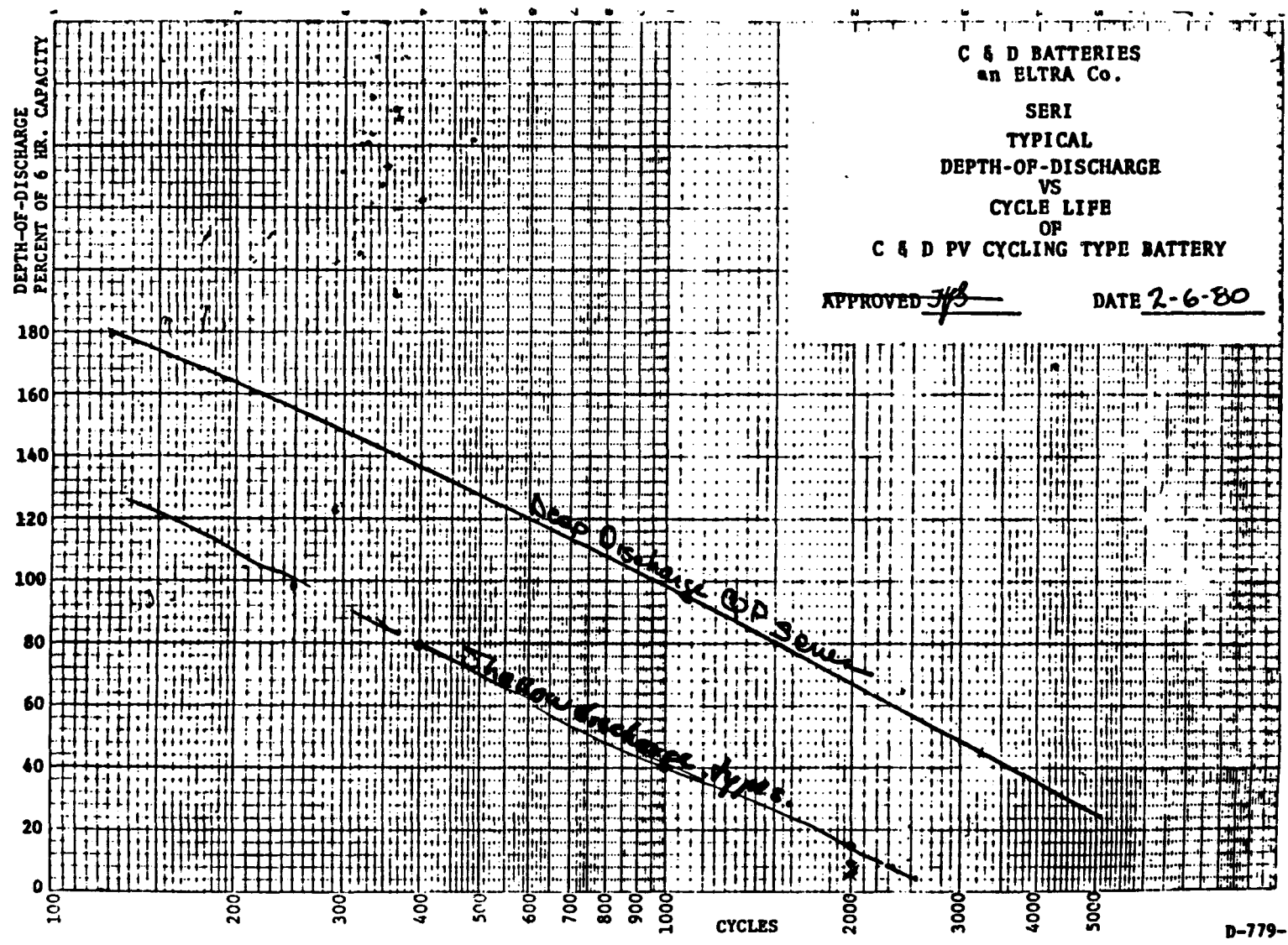

ESTIMATED CYCLE LIFE OF THE C&D K&L SERIES BATTERIES AS A
FUNCTION OF DEPTH-OF-DISCHARGE
FIGURE 3.6.4-2

3.6.5 Battery Modularity Options

A number of sub-options involving modular expandability were evaluated. The alternatives address the required modular change in battery energy storage capacity introduced by system power rating, designated load loss risk, and site specific variations in annual insolation level. General ground rules were generated, principally in recognition of several of the unique problems of isolated stand alone installations. The first was to limit the weight of the individual cell or package to a maximum of 175 pounds -- a weight manageable by several indigenous workmen.

The desirability of adopting a monopolar 120 VDC nominal bus was also acknowledged, even though the array currents for fractional kWp systems were low -- in the 2-5 ADC range.

3.6.5.1 Multicell Packages with a Single AH Capacity

Installation and maintenance labor content are reduced when multi-cell factory packages are used. For a 60 cell (120 volt nominal) battery, six cell (12 volt), or twelve cell (24 volt) increments are comparatively more cost effective than a string of single cells. The ampere hour capacity of a twelve cell module must be less than 250 AH to stay within the 175 pound limit. Series modules of six cells each would be required for the 1 PU (1 kWp nominal basic rating). The basic block is replicated for the higher power autonomous systems or in specific sites with high storage factors.

3.6.5.2 Single Module Multicell Factory Packages

One alternative would be to factory install the basic battery increment in one or several packages. Lift truck and other electromotive packages use a large number of multiple cells, typically 24, 30, and 48. Even for low AH capacities the weight of a 48 or 60 cell unitized package becomes formidable; for example, a 60 cell, 200 AH module would weigh in excess of 1000 pounds. While attractive from the reduced installation hook-up requirements, this weight would be prohibitive from the field handling viewpoint. Interior cells in a multicell package may encounter higher temperatures due to poorer heat removal as compared to the peripheral cells. One cell failure in a series string constitutes a battery failure; this failure mode could have a serious impact.

3.6.5.3 60 Cell Strings of Ascending AH Capacity

In this option, a maximum cell complement of 60 series cells was assumed, irrespective of the storage factor and the system rating.

Most industrial batteries, including photovoltaic, are sized by discharge amperes and ampere-hours per positive plate. A range of capacity of about six times would be obtained by change in plate count alone. Considering the standard variations in plate area for different cell types, a total amperehour capacity selection range from about 31 AH to 2520 AH is typically available in several industrial off-the-shelf product offerings. This approach, while increasing procurement complexity, had some advantages over expansion by replicating a large number of multiple strings. This option cannot, however, meet the 175 pound weight criteria.

3.6.6 Battery Costing

The following cost analysis was based on a peak 1 MW requirement per year.

Based on 125,000 watts continuous load and a 300 hours energy storage requirement, it is shown: $125,000 \times 300 = 37,500$ KWH storage for 1 mw storage per year -- 312,500 AH of batteries would be required for 120 VDC system. Using a typical PV cell rated 900 AH, at the 8 hr rate of batteries (each string capable of supplying the approximate 900 AH required at 120 VDC), 20,880 cells would be procured. Based on the highest discount available and GSA pricing, the cost came to \$5,548,234 for 1 MW/year of energy storage.

3.7 Load Management Strategies

3.7.1 General

The concept of load management implies a priority structure for loads. Such a structure can be constructed, beginning with the character of the load. It can be displayed as a two-by-two matrix in which loads are classified on one axis as essential or desirable and on the second axis as immediate or deferrable. Figure 3.7-1 depicts such a load classification in which:

- Class I - Essential and immediate
- Class II - Essential and deferrable
- Class III - Desirable and immediate
- Class IV - Desirable and deferrable

One may argue the assignment of a given load to a specific class, but the classification itself is a sound structure on which to examine load management strategy.

It is clear that not all applications will embody all classes. In fact, an unattended communication relay will likely have one class I load. A farm or small village (any place people live continuously) may have all four classes of load.

The distinction between immediate and deferrable is whether the end function has storage. Television is a good illustration. If one wished to see the 11 o'clock news, energy is going to be consumed at 11 o'clock, not midnight or 1 o'clock the next day. The video recorder is a form of storage, but does not defer energy consumption; quite the reverse, it defers only the need for one's presence. Water pumping, on the other hand, can have true functional storage, since the specific time that the water was stored and the time it was used are not functionally related.

The key point here is that water in the elevated tank is stored energy just like that in the battery. In PV systems, there are inevitably periods of surplus array output when the battery is fully charged. This surplus is free energy, and if secondary storage, such as a water tank, is cheaper than a battery (on a kJ-vs-kJ basis), then it makes sense to pump and store water during surplus periods. This can reduce the size of the battery as it does not have to furnish energy for water pumping during periods of autonomy when solar insolation is low or nonexistent.

CLASSES OF LOAD

ESSENTIAL

IMMEDIATE

- o Communication (P.S.)
- o System Control
- o Primary Function

DEFERRABLE

- o Water Pumping
- o Refrigeration
- o Light Manuf.

DESIRABLE

IMMEDIATE

- o Existing 50/60 H_z Motors
- o Hand Tools and Appliances

DEFERRABLE

- o Air Conditioning

FIGURE 3.7-1. LOADS CLASSIFIED IN A PRIORITY STRUCTURE
OF ESSENTIAL/DESIRABLE -VS- IMMEDIATE/DEFERRABLE

Refrigeration and air conditioning can be in the same class as water pumping if a high thermal inertia is given to the cold side of the system. This might be accomplished by freezing and thawing a containerized fluid whose melting point is slightly above the average desired temperature.

It is also conceivable that some light manufacturing operations might store inertial energy in a rotating flywheel. The motor that transferred surplus electrical energy to the wheel could be the generator that extracts it for intermittent manufacturing use. A variable-frequency, 3-phase motor would be well suited to this task.

The development of alternative energy conservation strategies and the detailed mechanization of stand-alone hierarchical power distribution systems are well beyond the scope of this effort. It becomes necessary, however, to include some rudimentary level of load prioritization in these stand alone designs.

The technical activity within the load management area has been specifically directed as follows:

- a. Load management functions will be mechanized by fixed assignment of relative priorities of up to four distribution feeders or buses. The user will have the option of assigning loads in accordance with these priorities, consistent with maximum permitted power demands from the individual feeders.
- b. Predetermined levels of battery state-of-charge will be used for shedding loads in inverse order of their essentiality.
- c. Control loops will be continued to the power controller circuits; supervisory control will not be remotely exercised.
- d. Sensors will be provided to sense battery state-of-charge at various levels; these signals will in turn activate solid state trip circuits causing a designated output contactor to open -- thus shedding that particular load.

Mechanization of the power control circuits is quite straight forward; however the selection, design and specification of transducers that will dependably indicate the actual battery state-of-charge in the operating environment, over the equipment life time, will and has been a pivotal mechanization problem that had to be solved.

3.8 Load Management (LM) and Battery State-of-Charge (S.O.C.)

3.8.1 Review of the Measurement Art

The purpose of load management for Photovoltaic (PV) Stand-Alone systems is to maintain a battery charge which is at all times greater than some minimum dictated by lesser loads. Implicit in the concept is a knowledge of the actual, available charge in the battery. Practical implementation of LM further requires this knowledge in near-real time, preferably hourly. Identification of a practical, reliable, "off-the-shelf" methodology providing a running assessment of the energy remaining in the battery became the major thrust of this analytical phase.

Load Management and the battery state-of-charge measurement are inextricably coupled. There are several ways to measure or to estimate the charge state; unfortunately, most are not appropriate to the frequency of measurement and updating required for this application. Several potentially useful methods are under development; other promising approaches have recently been announced in trade publications. At the onset of this investigation, however, none of the available methods provided a packaged solution meeting all of the functional requirements.

3.8.2 Specific Gravity

Specific gravity of the electrolyte, when corrected for temperature and referenced to the initial specific gravity for the cell, is an excellent indicator of state-of-charge. A plot of this characteristic is shown in Figure 3.8-1. Specific gravity (corrected to 27^o C) in lead-acid battery systems is reduced by 0.001 during discharge for each 0.46 ampere-hours/ liter of electrolyte. The AH capacity, as a function of temperature, is a battery design parameter, and the density correction for the electrolyte at temperatures other than 27^oC is well known. If the initial density is known, then specific gravity and a simple look-up table should yield the charge state. The measurement technique must be developed if any specific gravity sensing method is to be practicable.

A monitoring probe based upon the optical detection of the position of calibrated temperature-compensated gravity balls is offered by DELTAR as a standard product. The balls are calibrated to preselected specific gravity ("float-sink") transition points. In the "float" position, the light beam between a LED source and a phototransistor is interdicted. Once the gravity drops below the transition point, the ball sinks, activating the beam. This probe, in combination with an electrolyte lift pump, should provide an acceptable short-term solution. Product sheets describing these sensors are included as Figure 3.8-2 and Figure 3.8-3 following.

3.8.3 Coulombmeter

A coulombmeter is used to measure the product of time and current, ampere-hours which are put into the battery during charging periods, and, conversely, those taken out during discharge periods. The difference, appropriately indexed for a starting point, should yield ampere-hours remaining (when corrected for temperature in a look-up table).

The problem with the coulombmeter is two-fold: first, the indexing of a starting point; second, the assumption of a linear system. The coulombmeter can only be indexed when the battery is at 100 percent charge. In a PV system, this occurs frequently during the summer, but that is usually the time when load management is not needed. When it is needed, (whether summer or winter), it is likely that the last index was not weeks, but months in the past. In the interim, several tens of charge-discharge cycles will have occurred at different temperatures and different rates. Each new error will be added to all previous errors, and the original index point will have been lost. Compensated coulombmeters have been recently announced; their price is in the \$800 range.

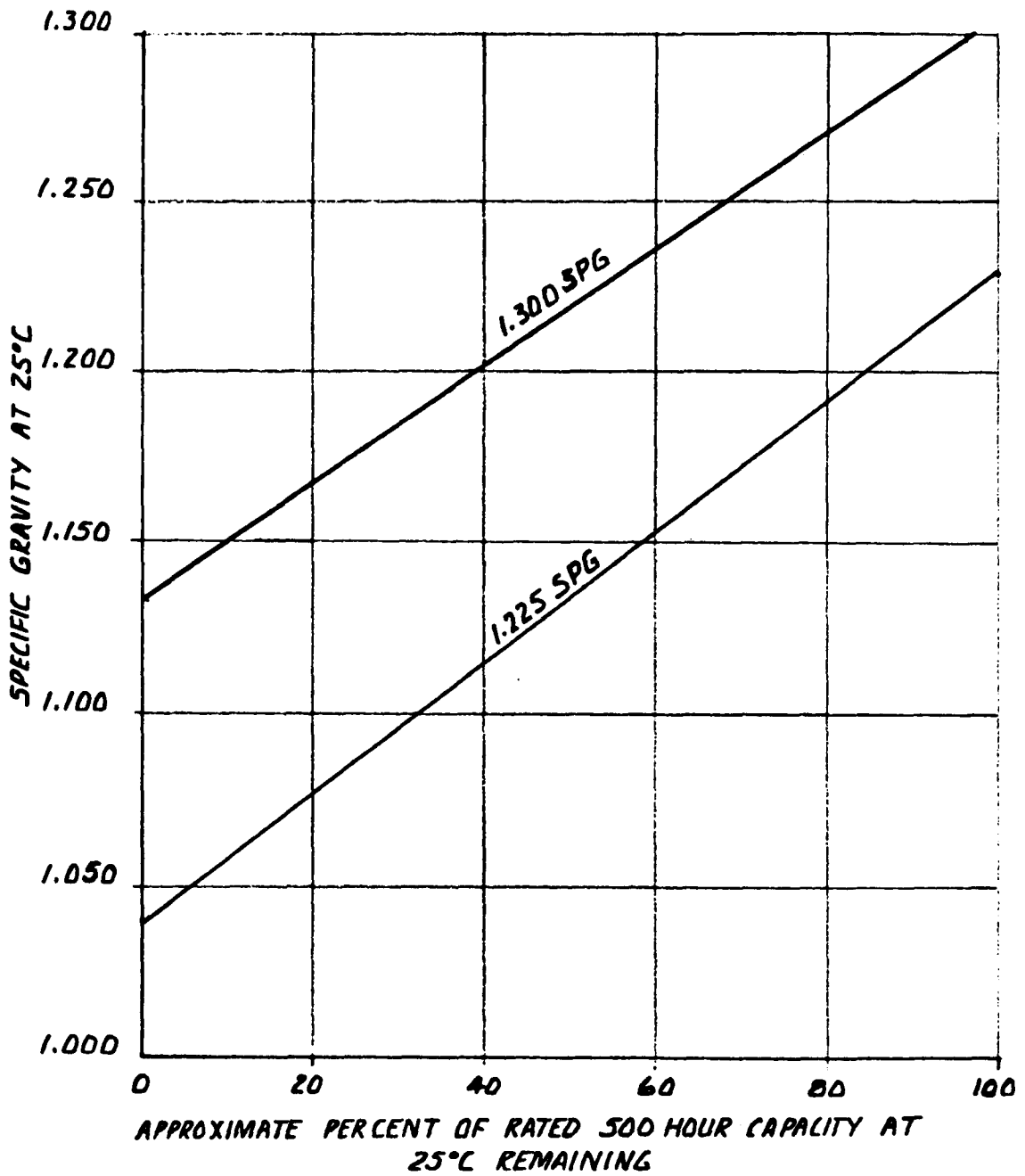

SPECIFIC GRAVITY VS STATE OF CHANGE
 FIGURE 3.8-1

3.8.4 Terminal Voltage Measurements

Terminal voltage can be used as an indicator of charge state. Figure 3.8-2 displays this characteristic at zero current. However, it must take into account temperature and battery current at the time of reading. The theory behind the terminal voltage reading comprises two parts: first, the reaction potential at the electrodes; and second, the IR drop in the electrolyte at the solid-liquid interface and in the metallic electrodes. In practice, all of these parameters are temperature dependent, but even without this influence, the probability of gross errors resulting from unknown parametric changes becomes quite high. To amplify, the terminal cell voltage is given by the following expression:

$$V_t = V_a - V_c - I_t (R_e + R_a + R_c + R_t) \quad (1)$$

where

V_t = Terminal Voltage	R_e = Electrolyte resistance
V_a = Anode Reaction Potential	R_a = Resistance at anode
V_c = Cathode Reaction Potential	R_c = Resistance at cathode
I_t = Terminal Current	R_t = Interface metallic terminal resistance

Most of the above parameters are in turn influenced by such factors as battery service history, age, recent charge discharge profile and electrolyte density and/or stratification. Mechanization of a survivable S.O.C. measurement subsystem based upon this approach appears remote.

One device for determining the specific gravity of the electrolyte by measuring the open circuit cell potential is the Digital Hydrometer manufactured by EMF Instruments, Inc. This instrument uses the cadmium electrode method to determine the specific gravity of a lead acid cell and its state-of-charge. According to the manufacturer, it measures the potential difference between the reference (cadmium) electrode and the positive pole to obtain the specific gravity. The voltage measured by the cadmium electrode is 0.16 volts less than the open terminal voltage of a good quality cell. Again, according to the manufacturer, the specific gravity of the cell is given by:

$$S.G. = \text{Open terminal EMF} - 0.84 \quad (2)$$

The derivation of this algorithm is not readily apparent, but the designer appears at least to have established a consistent empirical relationship. This method shows little immediate promise, principally because of many unknowns and the extreme difficulty of repetitively monitoring the zero current potential of cells in continuous use. Measurement stabilization time alone would render this approach virtually prohibitive.

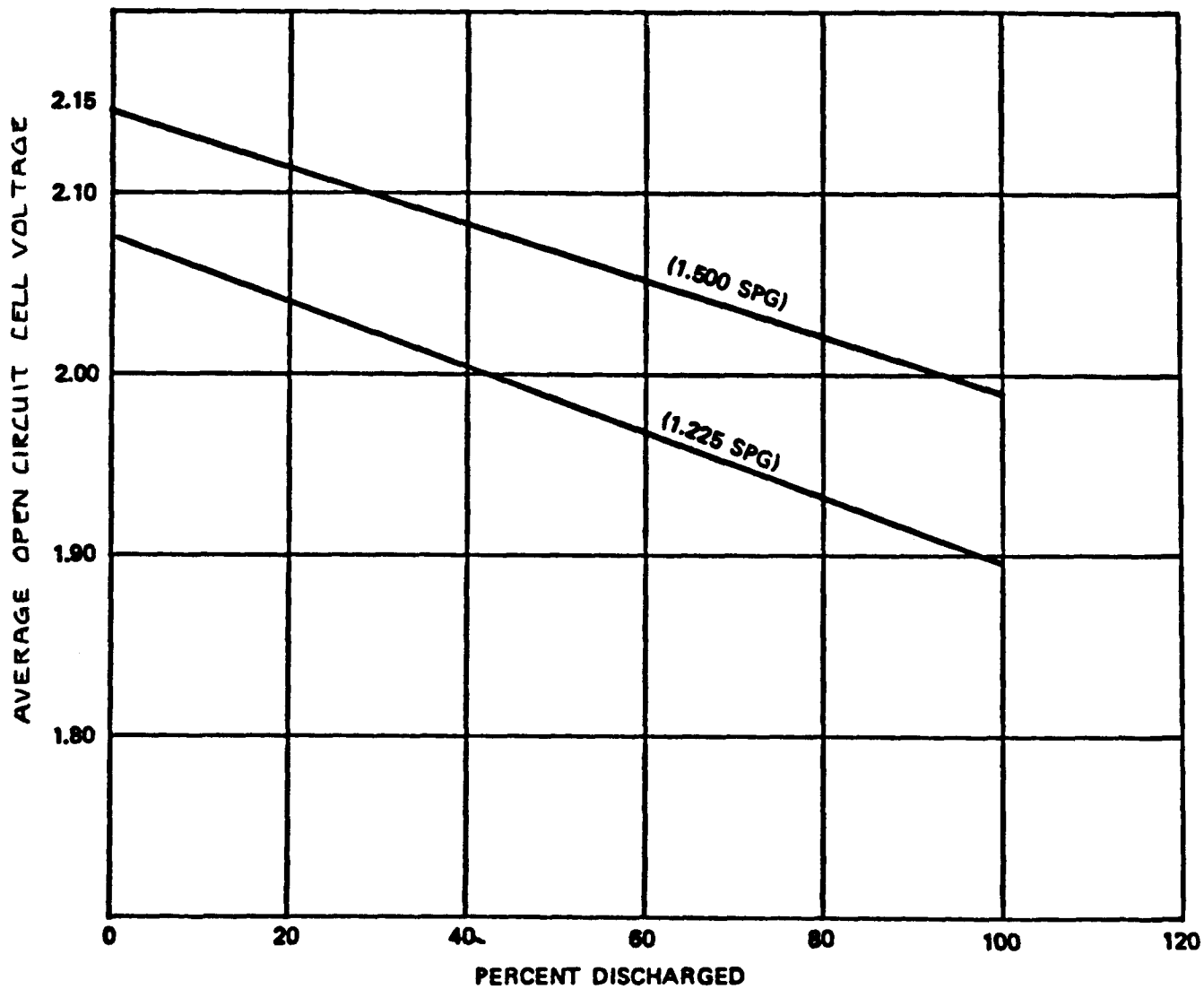

APPROXIMATE OPEN CIRCUIT VOLTAGE OF TYPICAL LEAD-ACID CELLS AT VARIOUS DEPTHS OF DISCHARGE (DOD) FOR 25°C AMBIENT
 FIGURE 3.8-2

3.8.5 Current/Voltage Measurements

If current flows in the cell terminals, we must consider the terms R_e , R_a , R_c in equation 1, paragraph 3.8.4. The term, R_e , depends upon electrolyte conductivity and the state of the pores in the separator. In a new cell, the pores are filled with electrolyte. However, as the cell ages, the pores become clogged with quasiinsulating material and are diminished as effective channels for transport of the ionic species in charge or discharge.

The electrolyte conductivity (corrected for temperature) is a direct measure of specific gravity and hence the percent of possible charge, as shown in Figure 3.8-3. The reduction in conductivity with pore closing reflects a reduction in the possible charge as a result of battery aging. Thus, R_e is a good indicator of available capacity. The same is true of R_a and R_c , although here the values are chiefly determined by the aging of the battery. Thus, the term $(R_e + R_a + R_c)$ is, when temperature corrected, a good estimate of the inverse charge remaining.

The problem with detecting charge state from $(R_e + R_a + R_c)$ is that the numerical value is rather low, and thus a moderate current is required to make the resistive voltage drop significant with respect to the reaction potential of the electrodes. If it were not so, the battery would be very inefficient. Figure 3.8-4 indicates the general shape of curves for cell voltage versus charge state at two values of discharge current.

A reliable algorithm developed from the battery I-V characteristics at moderate to high discharge currents can undoubtedly be mechanized; the interfering parameters previously discussed appear to be manageable. However, no equipment has been found that will directly solve this immediate problem.

One manufacturer (Motorola) offers a related device that measures cell conductivity at a 100 Kilohertz. It has been designed specifically for determining battery aging or proximity to wear-out. Not being a true state-of-charge measurement device, it has been rejected.

3.8.6 Summary of Findings

An accurate daily estimation of the charge remaining in the battery is required. Although several methods exist, most have fundamental drawbacks for stand-alone PV applications.

- (a) Specific Gravity - Some automation problems expected; subject to possible errors from electrolyte stratification; however, an off-the-shelf, mechanization approach using the DELTAR probe has been developed. The stratification problem appeared manageable with the use of a small electrolyte lift pump on the pilot cells.
- (b) Coulombmeter - Requires periodic reset when 100 percent charge is reached; accuracy deteriorated steadily after reset. In PV systems it is most accurate when not needed (frequent full charge) and of questionable accuracy when needed.

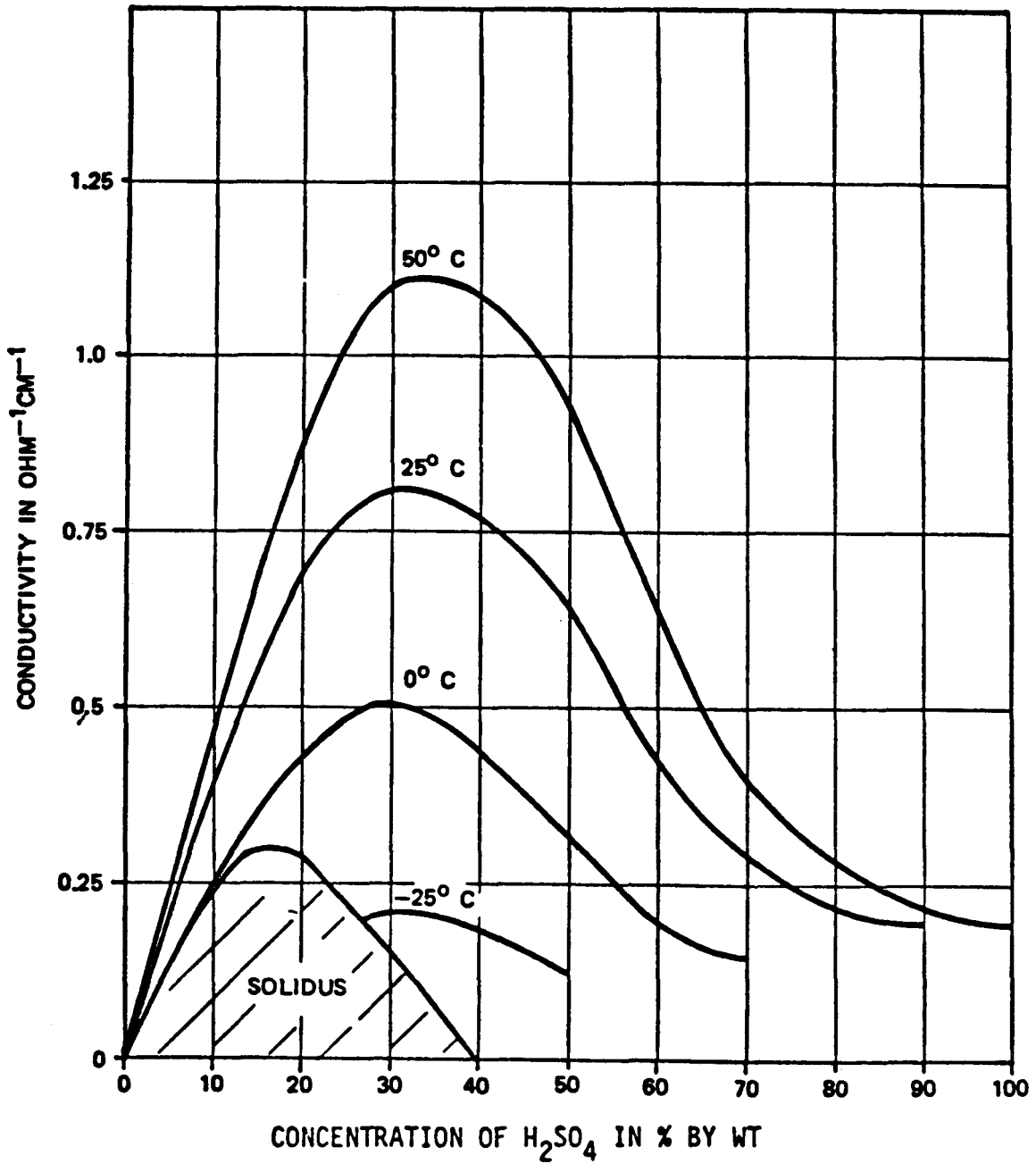

ELECTROLYTE CONDUCTIVITY VERSUS SPECIFIC GRAVITY AND TEMPERATURE
 FIGURE 3.8-3.

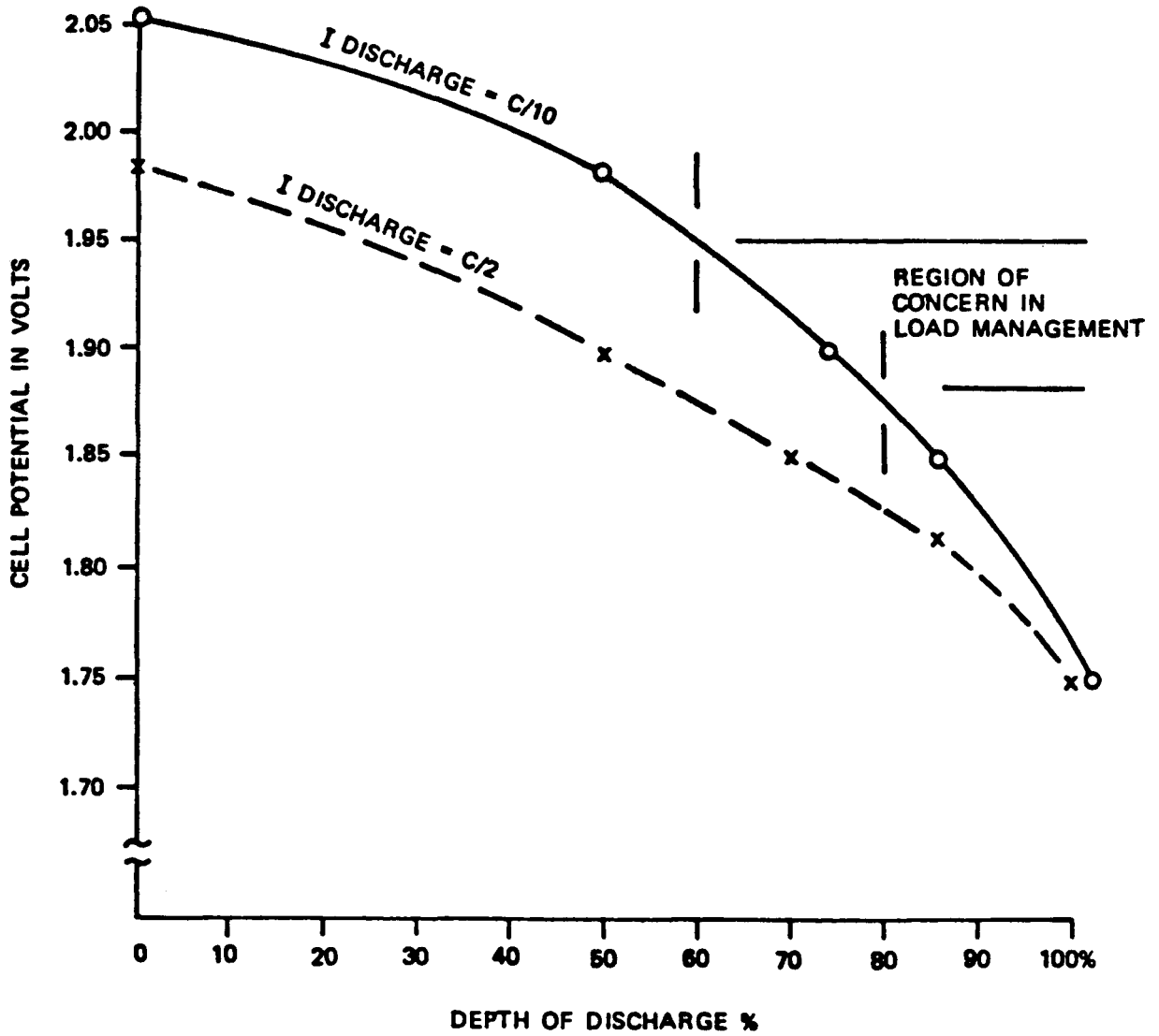

DEPTH OF DISCHARGE AS A FUNCTION OF CELL POTENTIAL UNDER LOAD
 FIGURE 3.8-4.

- (c) Terminal Voltage at Zero Current - Subject to gross errors from stratification and other cell parameters; serious difficulties expected in attempts to mechanize for an on line battery. No product specifically for SOC measurements was found to exist.
- (e) Terminal Voltage at Moderate Discharge Current - a utilization of this approach requires the following:
 - o development of a S.O.C./I-V algorithm free of degrading parametric influences.
 - o mechanization of the required analog or digital computational circuits.
 - o design of pulse forming power network.

A realistic developmental project could be readily generated in solution of the above requirements; however it would be well beyond the scope of this study.

Hughes therefore recommends approach "A," that of measuring the specific gravity of the battery with the DELTAR probes.

3.9 DC Power Switching and Interruption

DC power generation, transmission and distribution has always been beset by two major obstacles, inability to conveniently transform voltages, and difficulty in assuring power interruption. The designer of PV power systems must squarely address these inherent switching problems; otherwise, the system design will be inadequate and quickly fail.

A 1 kWp PV array charging a 60 cell (120 volts nominal) battery typically exhibits a min/max voltage range from about 95 VDC (1.75 VPC at end of discharge) to about 170 VDC (open circuited with sufficient insolation). With the batteries connected, the charge voltage cut-off point (float potential) at 25°C is about 147 Vdc; correspondingly, the nominal charging current is about 8.7 amperes. Interrupting current of this magnitude cannot be accomplished with most conventional DC relays or typical low voltage AC contactors. For example, an unprotected AC industrial relay rated 25 amps, 277 VAC, 3 phase has no mechanism (nor does it require any) for arc blowout or threading; in equivalent DC service, unextinguished arc erosion would quickly destroy the contacts. Conventional low-voltage AC circuit breakers, even premium designs with arc "boxes" or chutes, will not survive many cycles of a relatively modest DC interruption level.

Inability to interrupt DC results from an absence of a "current zero." In noninductive AC power interruption, the current wave crosses the zero axis every 8.3 milliseconds. If the contacts can part in that period, and the dielectric gap recovers, interruption, with minimum low arcing, is assured. Even HVAC circuit breakers will safely interrupt in 10 cycles. The current zero may be delayed in AC circuits when asymmetrical components are present due to inductance; current reversal does, however, ultimately take place. Interruption of PV array current had some of the unwanted attributes of combined DC and inductive source interruption. The rise in open circuit voltage plus the quasi-constant current nature of the array I-V characteristic can continue to support an arc struck between the parting contacts.

There are a number of product lines of rugged DC contactors for control of DC power in stationary electrical machinery, electromotive, and other applications. The devices feature extended arc boxes or chutes above the contacts, various forms of magnetic blowout, arc horns, and they use special arc-quenching materials. These devices, while reliable and capable of many interruptions, are not inexpensive. For example, a 2 pole, 25 amp contactor rated 230 VDC lists for \$260. A 600 volts, 1 kA contactor lists for more than \$900.00.

Both the derating and the cost impact become more pronounced when the lower power relays are examined. For example, the price of a square D class 7001 relay in a DPST configuration is \$114. The AC interruption rating for inductive (35 percent PF) service ranged from 6 amps @ 120 VRMS to 1.5 amps @ 480 VRMS. For inductive and resistive DC service, both the make and break ratings at 600 VDC collapse to 200 milliamperes. Other electromechanical devices, including circuit breakers, loadbreak switches, and crowbars also require this additional protection.

The high voltage DC switching technology for bulk power transmission uses several techniques to commutate the arc energy out of the main contacts and to ensure reliable interruption. One method is using very fast auxiliary switching devices in parallel with the main gap. Figure 3.9-1 depicts this sequence. In this example, the main contacts are commanded to open; the fast switch has been previously turned on by an initializing command. As the main contacts part, the path through the fast switch momentarily becomes the main current path. With this current diversion, the main contacts continue to part in a virtually arcless manner. In the absence of a sustained main contact arc, virtually no recovery of the gap has to occur; when the contact separation has reached about 0.015," a D.C. dielectric withstand in excess of several hundred volts is reasonably assured. The parallel static switch can then be turned off. In relatively low voltage operation, a power transistor Darlingtion switch can be used. At higher power levels, OFF commutated thyristors would be compatible. For high voltage DC interruption (to 150 KV), Hughes successfully employed both SF₆ and oil breakers/contactors in combination with its cross-field tube.

Another successful method for interrupting high power DC uses the circuit given in Figure 3.9-2. Upon command to "open," the dv/dt capacitor in charging delays the voltage rise across the parting contacts, giving the gap an opportunity to recover.

The energy that would have formed the arc has now been commutated into the capacitor, which charges up to the crest potential difference. The metallic oxide varistor serves as a clamp to absorb and dissipate the surge energy which would be released by discharge of the line reactance. The MOV also limits the voltage excursion, thus protecting the capacitor, and prohibiting restrike of the recovering contact gap. This configuration has handled transient voltages to 80 KV at currents to several kiloamperes in MRTB (Metallic Return Transfer Breaker) service on DC inerties.

Another high voltage configuration, the injection of a reverse current flow to momentarily establish a current zero, is depicted in Figure 3.9-3.

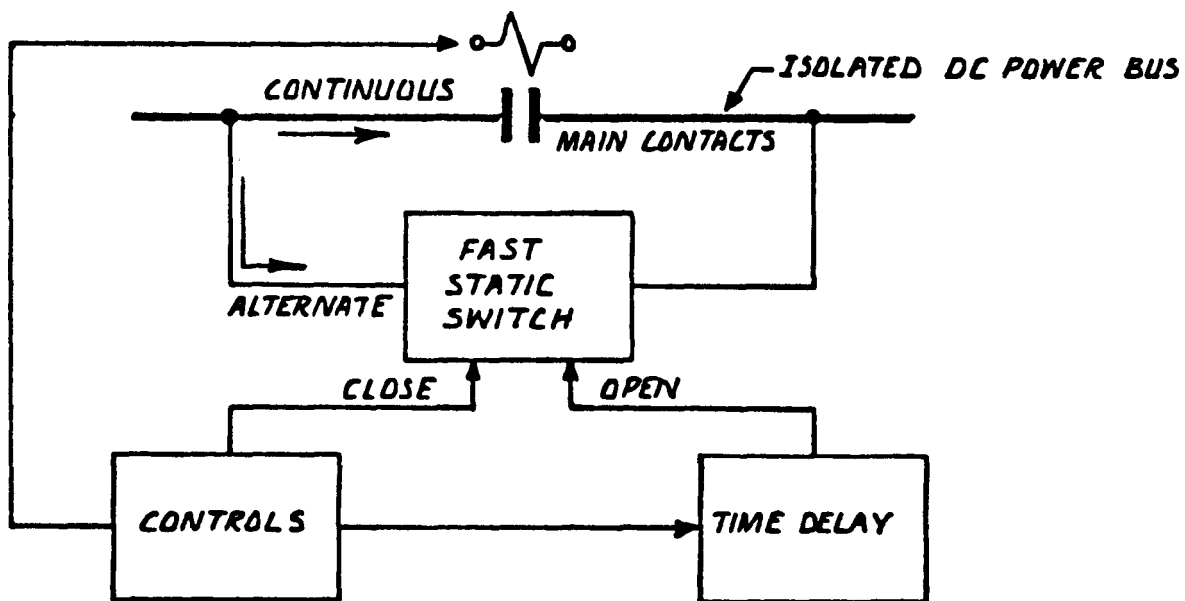

ARCLESS DC INTERRUPTION BYPASS STATIC SWITCH
 FIGURE 3.9-1.

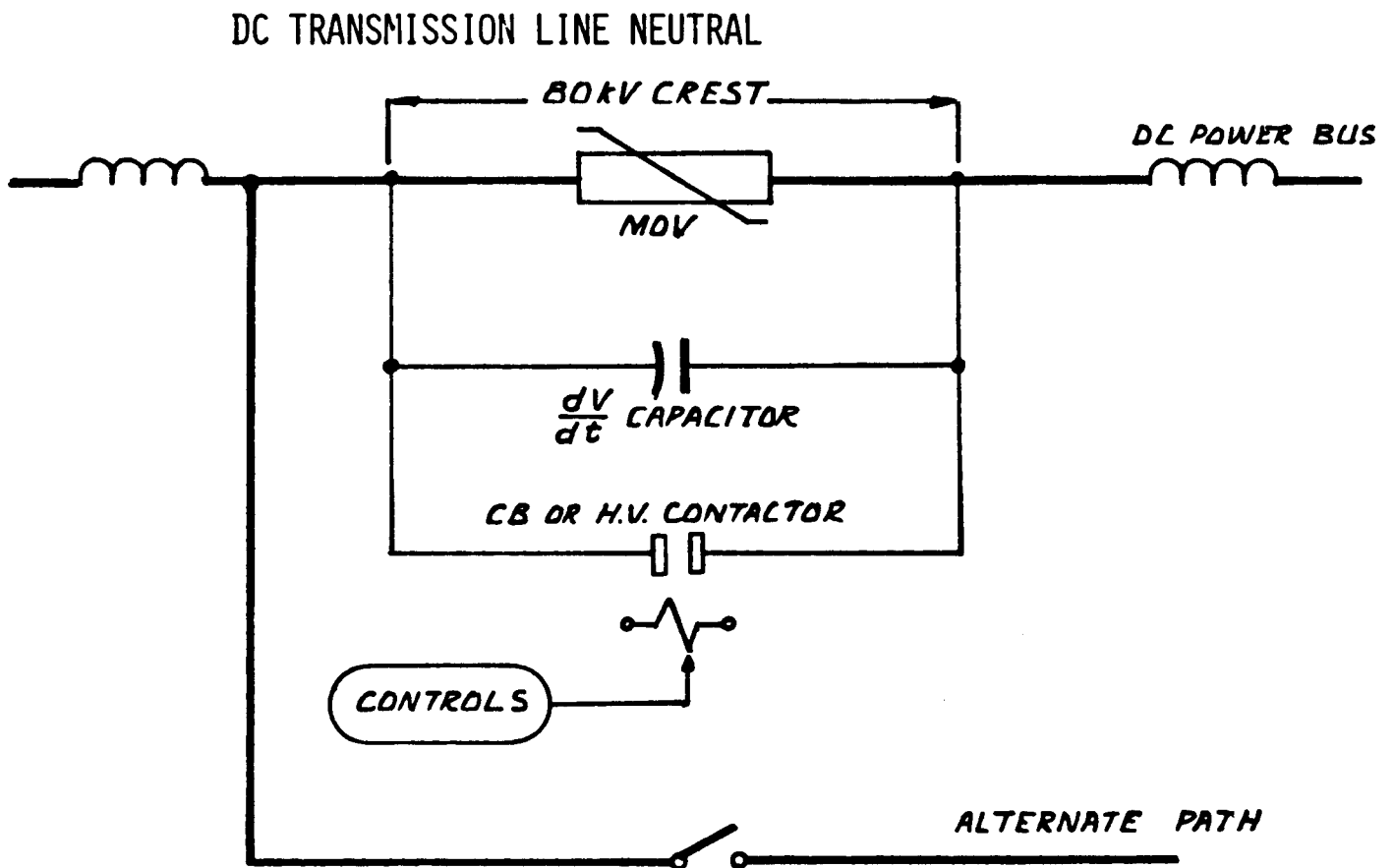

HVDC POWER TRANSFER WITH COMMUTATING CAPACITOR
 FIGURE 3.9-2.

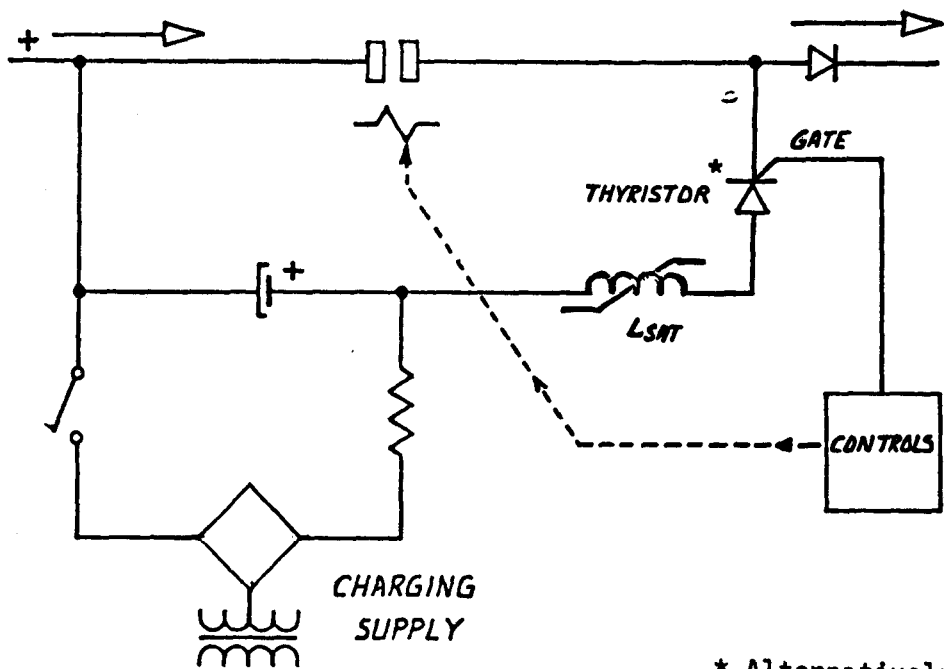

* Alternatively, an ignitron

ARCLESS DC POWER INTERRUPTION: CURRENT ZERO METHOD
FIGURE 3.9-3.

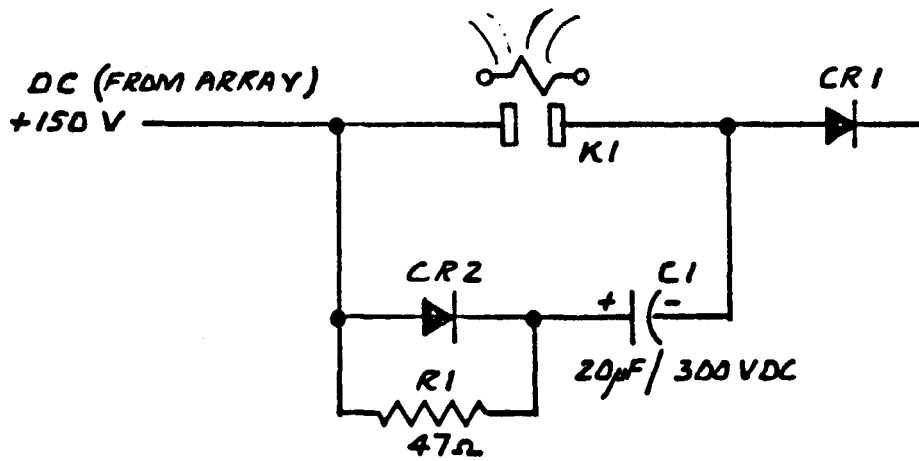

Arcless DC Power Interruption : Snubber Method
Figure 3.9-4.

Preparatory steps include charging the capacitor, the source of energy for the countercurrent. Upon the interruption command, the thyristor is fired and the capacitor discharges through the loop consisting of the saturable reactor L_{SAT} and the main contacts. When the current flow is approaching reversal, the main contacts began to part; L_{SAT} sustains constant current flow when its core drops out of saturation. Main contact parting is virtually arcless.

Figure 3.9-4 depicts the snubber method, the one selected for usage across power switching contacts in the power controller. At the instant of contact parting, the potential difference across the contacts is the diode voltage drop. The capacitor, initially at zero potential, charges through the diode, and commutates the energy out of the parting gap. Due to the diode drop, the contact potential drop on parting contacts is about one volt. This is well below the first ionization potential of the contact materials and causes no problem. The gap can recover; restrike will not occur if the constants are properly selected. R_1 is added to discharge safely the capacitor on reclosure to ready the contactor (or circuit breaker) for successive interruptions. The value of R_1 is set by safe maximum capacitor discharge current; when the contacts reclose, this would be about 2.5 amperes for a 120 volt system. Using a hermetic mercury displacement relay, the snubber should extend the interruption life to that of the mechanical, about 4,000,000 cycles.

Testing was done to verify the selected concepts. Typically, with open frame power contactors, only minor sparking was observed at 250 VDC and 30 ADC, and virtually none at 8-10 ADC.

3.10 ELECTRICAL PROTECTION

Design alternatives for this BOS element were identified, and final trade-offs were made. Summary comments follow:

3.10.1 Grounding

Adequate system grounding is important because it maintains the systems elements at a safe and known reference potential (usually a few volts or less), and it provides a high conductance path for positive diversion of lightning induced current surges. Several promising approaches were identified:

- A. Concrete-encased Electrodes.
- B. Ground-rod Cluster.
- C. Buried Metallic Counterpoise.

Although all of the above methods can be deployed effectively, the buried metallic counterpoise, Option C, yielded the lowest cost. Using a 1/4" hot-dipped galvanized steel wire, a ground resistance of less than 10 ohms was computed for sandy desert soil, with wire burial at about 18 inches. A perimeter length of 400 feet, with diagonally crossed radials, was assumed in the simplified model.

3.10.2 Lightning Protection

The use of lightning rods on masts on each of the north array corners, plus a lower interconnective aerial counterpoise, was originally recommended for the maximum power 15kWp system. Use in connection with the buried metallic counterpoise was also projected. A 15kWp array field would have been approximately 107 ft. x 95 ft. Two rods 30 ft. high, spaced 24 ft. south from the north corners would have provided adequate coverage. The principal options here were to:

- A. Include a simple system, irrespective of the thunderstorm day incidence of the planned site.
- B. Delete the lightning protection kit for all sites wherein the array is closely surrounded by much higher metallic structures.
- C. Delete the lightning protection kit for sites of known low isokeraunic incidence, i.e., less than five thunderstorm days per year.

The decision to include or to delete the lightning protection kit therefore becomes one of a site specific nature.

3.10.3 Bonding and Shielding

Because of possible wide variation in ground resistance for a range of sites, it was recommended that some supplemental bonding straps and frequent tie-points to a buried counterpoise be employed. The array field then becomes an equipotential system, able to survive transient surges, even if the ground resistance is high.

3.10.4 Voltage Limitation

No additional evidence had been found indicating a long-term onset region drift in quality metallic oxide varistors. Accordingly, the more expensive supplementally gapped MOV assembly was not further considered.

3.10.5 Protection from Electrical Faults

Table 3.10.1 lists the electrical faults that might occur in photovoltaic array fields, their probable origin, consequence, and comparative ease of detectability.

Referring to Table 3.10.1 a number of conditions become apparent:

- A. Only line-to-ground (common mode) high impedance faults are readily relayed. Similar transverse mode faults are not directly detectable.
- B. Proper dielectric integrity and high neutral-to-ground resistance could protect personnel against common mode currents above the let-go level.
- C. Both common and transverse mode bolted faults have to be relayed to preclude sustained partial or total outage and to prevent sustained arcing damage.
- D. Sectionalization limits the extent of an outage and permits the system to continue delivering energy at a fractional power level.
- E. The electrical protection strategy weighs some unquantified future risk and outage probability against the cost of such protection. This future hazard might result in an injury or lethal accident, or

it may lead to an unspecified loss of capital equipment and generation time.

Type of Fault	Designation	Fault Current Magnitude	Probable Origin of Cause	Probability of Occurrence	Recommended Remedial Action	Consequences of Deletion of Protective Response	Ease of Detectability	Relaying Methodology
Positive or Negative main to ground ($H_1 Z$)	(+)L-G (-)L-G	$H_1 Z$, i.e., $I_F < 30MA$	Grounded person accidentally in contact with isolated mains.	A hazard with reasonable probability.	Set ground reference resistor so that let-go current not reached. Crowbar on 7-15 MADC within 50 milliseconds.	Sustained voltage; personnel must take their own survival action.	Straight forward with isolated shunt or sensor.	a) current flow in neutral-to-ground link or, b) differential current in branch collector.
Positive or Negative main to ground (bolted)	(+)L-G (-)L-G	Bolted, i.e., I_F could reach available branch array current.	Mechanical destruction, i.e., falling object or power equipment usage accident.	low, once installation completed.	Same as above; ground resistor limits fault current. Crowbar array when 7-15MADC limit reached.	All, or a portion of the array field will suffer outage.	Same as above.	Same as above.
Positive or Negative main to Neutral ($H_1 Z$)	(+)L-G (-)L-G	High impedance, i.e., $I_F < 30MA$	Leakage, or person accidentally across power cable conductors.	Low.	No direct solution to potential problem.	No direct protective response available. (N/A)	Most difficult to detect low fault currents by direct means.	None planned.
Positive or Negative main to Neutral (bolted)	(+)L-N (-)L-N	Bolted, i.e., I_F can reach short circuit current capability of branch.	Mechanical accident.	Low during normal operations.	Provide blocking diode isolation; voltage trip appears most reliable.	Sustained loss of all or portion of array power, depending upon level of sectionalization; possibly destructive arcing.	loss of voltage, (if in diode isolated branch).	Alarm; undervoltage crowbar trip.
Positive or Negative and neutral, all to ground	(+) L-N-G (-) L-N-G	Bolted fault; I_F approaches short circuit capability of branch.	Massive mechanically induced fault.	Low.	Branch voltage sense and relaying; Ground-to-neutral current may or may not flow.	Sustained power loss on all or portion of array; function of sectionalizing level. Possible destructive arcing.	Loss of voltage, and: 1) no ground current flow or, 2) some ground current flow.	Alarm, undervoltage crowbar trip; possible ground fault relaying also.
Neutral to ground (bolted or low)	N-G	No fault current magnitude as such. Draastic change in N-G impedance.	Neutral-to-ground short, or low -Z sneak circuit.	Low.	Only solution is to monitor N-G resistance.	Loss of dielectric integrity. Increase in personnel hazard in absence of ground fault current limiting.	Only by monitoring.	Non-planned; correct this unwanted sneak ground.

Table 3.10-1 Fault Scenario For Stand-Alone Systems

The following alternatives are available:

- A. Deletion of all ground fault protective circuits and their attendant cost; depend upon perimeter security to circumvent accidents; i.e., "Trespassers proceed at their own risk."
- B. Deletion of transverse mode bolted fault protection and undervoltage relaying and associated cost. Use of the system inability of to support a load as a means of signalling an out-of-tolerance condition.
- C. Operate on the premise that the protection of operating personnel from certain hazardous events is mandatory, thereby justifying inclusion of some protective circuits on this basis alone.
- D. If "A" and "B" above are not deleted, determine the optimal level at which such protection must be applied:
 - 1) Sectionalize and protect at the modular increment level, typically 1kWp.
 - 2) Do not sectionalize; protect only at the system level, irrespective of the power output of the field.
 - 3) Sectionalize and protect at some intermediate level, for example 4kWp.

3.10.6 EMI/Surge Control

3.10.6.1 Electromagnetic Interference (EMI)

Photovoltaic arrays cannot in themselves generate EMI; the devices coupled to them, inverters, DC-DC converters, switching regulators as well as arcing shorts, do have a potential for generating radio interference.

An assessment of the potential of intermediate sector fields was made in support of a contractual effort under the Sandia Laboratories contact "Photovoltaic Array Field Optimization and Modularity Study," Contract 62-9188. This study identified the possible interfacing sources of RF energy, level of radio service interference, characterized the radiating elements within the array field, and gave examples of EMI safeguards for these larger fields. The following conclusions were reached for the intermediate sector fields:

- A. Unburied feeders could appear as 1/2 wave dipoles at some frequency within the service spectrum.
- B. Radiation resistances are in the milliohm range.
- C. Sub-feeder interaction could be a potential source of spurious excitation.
- D. If no remedial action whatsoever were taken, unwanted signal propagation, as the result of high ripple injection (typically to 40Khz non-sinusoidal waves at 25ft. relative amplitude), could cause out-of-specification interference at several miles distant.
- E. The inclusion of simple R-C snubbers across collection (summing) points, plus shunt filters on the main feeders, reduced this potential problem to insignificant levels.

Shunt switching regulators of the continuously sampling PWM type could possibly excite the array field output at sub-millisecond rates; some interference could potentially exist. The regulator designs considered the most cost effective are free running and not of the carrier type. These proposed designs can readily incorporate a simple R-C input snubber. It was concluded that with minor EMI control precautions, the probability of a stand-alone PV system being an unwanted EMI radiator was very remote. This topic should not be of further concern.

3.10.7 Rankings/Recommendations Preparatory to Conceptual Design

The following rankings and recommendations were given prior to initiating the conceptual design tasks.

3.10.7.1 Grounding

Establish an earth low impedance (ground) reference for all system installations.

3.10.7.2 Lightning Protection

Include kits in regions of high isokeraunic activity; delete kits when higher adjacent structures exist, or isokeraunic activity is low.

3.10.7.3 Bonding and Shielding

Ensure good mechanical bonding on all array structural elements; run separate ground to Power Controller and make available to load.

3.10.7.4 Voltage Limitation

Use properly rated metallic oxide varistors (MOVS) on all I/O ports.

3.10.7.5 Fault Protection

Provide one system Ground Fault Relay that activates all crowbars. Depend upon surge protected distribution breakers and UV trip for load faults; provide battery with backup fuse, and safety "Supercon" mechanical disconnect; relay transverse mode array faults by loss of voltage/power observations.

3.10.7.6 EMI/Surge Control

Limit remedial action to the simple R-C snubber previously described.

3.11 ENVIRONMENTAL PROTECTION OF BATTERIES

3.11.1 General

General requirements for battery protection are:

- A. Protect the battery against wind-blown dust and rain, and possible theft, vandalism, and personal hazard.
- B. Be well ventilated, and thus prevent a hydrogen hazard, and assist in reducing electrolyte temperature in hot environments.
- C. Protect the batteries from direct solar radiation and the subsequent

temperature rise.

- D. Be low cost, simple to assemble and install, and of long life.

The most promising candidates for both the racks and the shelter appeared to be concrete block and wood, or some combination thereof. In sustained sub-zero temperatures, a special insulated enclosure was first visualized as a means of raising the minimum electrolyte temperature and protecting the battery against freezing. We also looked into the possibility of burying the batteries to a sufficient depth in a totally enclosed "crypt." The purpose here would be to advantageously employ the moderating effect of the earth below the diurnally sensitive surface layer. A brief analysis indicated a subterranean enclosure equivalent to a mine shaft or a walk-in cave would begin to show beneficial results. Shallow subsurface "pits" would only exacerbate the thermal problem.

The list of viable candidates was reduced to the following three developmental concepts:

- A. A central "PreFab" battery enclosure.
- B. A native material enclosure.
- C. Dispersed "under the array" battery housing.

3.11.2 Central Prefab Enclosure

A typical prefabricated enclosure is depicted in Figure 3.11-1. A low cost factory kit designed principally for temperate and equatorial zone applications was envisioned. The following criteria were used:

- A. Shade the battery from direct sunlight.
- B. Meet a target weight not exceeding 10-15 percent of the batteries.
- C. Permit cross-ventilation of cell array and nighttime cooling.
- D. Protect the batteries against windblown dust and rain.
- E. Protect against theft, vandalism, and intrusion.
- F. Employ materials readily available world-wide.
- G. Allow for assembly by unskilled labor.

Four enclosure sizes (8 ft. x 6 ft.; 8 ft. x 8 ft.; 8 ft. x 12 ft.; 8 ft. x 24 ft.) were evaluated using various methods of construction, such as concrete block and mortar, aluminum, various wood shapes, and plywood. Concrete block was eliminated because of its unavailability in some areas, high cost of transportation, need for "skilled" labor, and overall high final cost. Sheet metal and aluminum were considered to be practical only if the enclosures were prefabricated in the U.S. and air shipped to the sites, however, the costs were higher than those for concrete block. Various wooden structures were considered, with plywood being the most practical and meeting all of the requirements. The design of the enclosure, using plywood, could be prefabricated into sections in the nearest city or village, painted, transported, and assembled on the site. The plywood acts as a structural "skin" and eliminates the need for diagonal bracing.

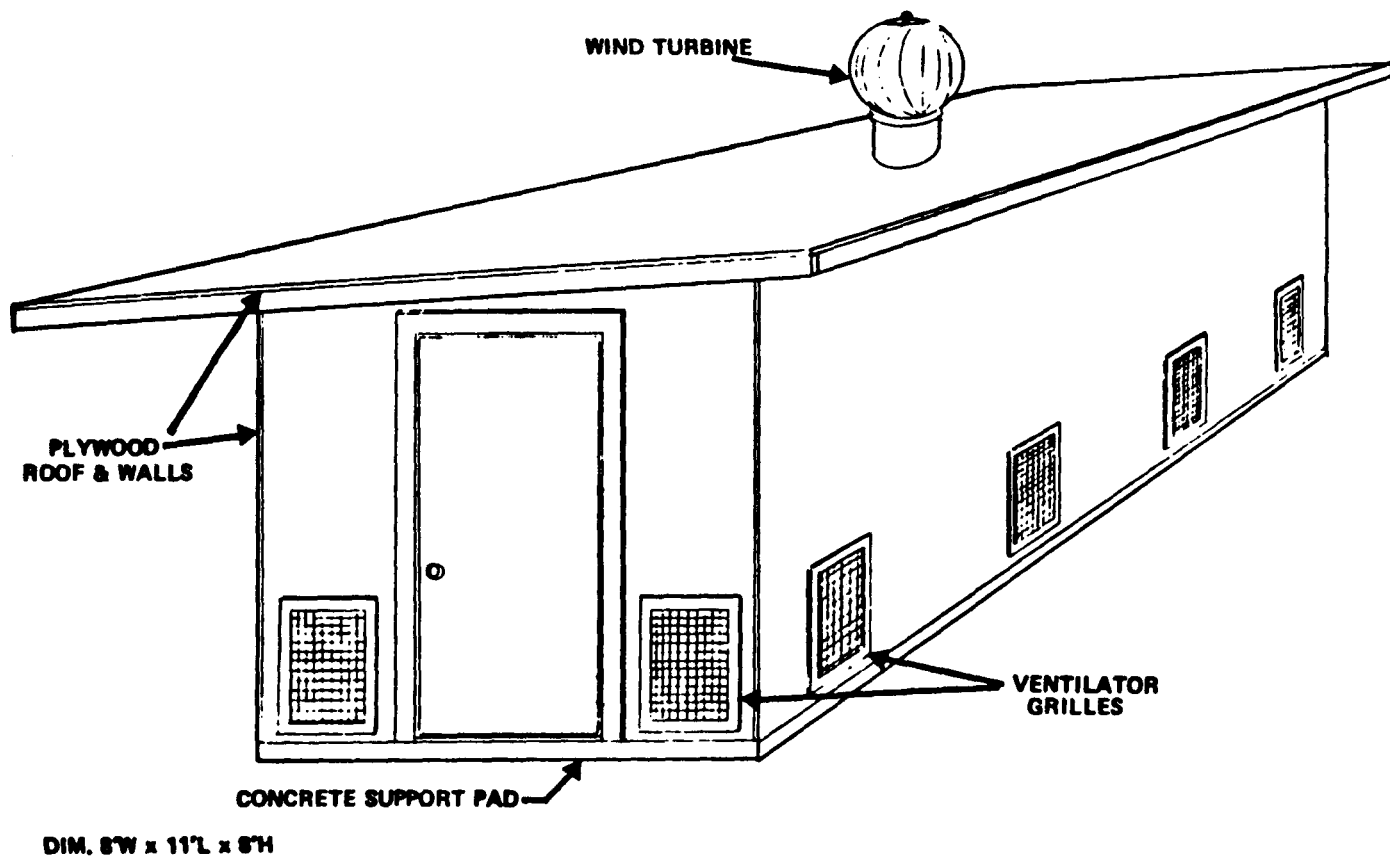

CENTRAL BATTERY ENCLOSURE "PRE-FAB" OPTION
FIGURE 3.11-1

3.11.3 Native Material Enclosure

For temperate climates, and in areas where finished lumber and other normal construction materials are scarce or the costs prohibitive, another alternative battery enclosure using principally native materials was investigated. The enclosure shown in Figure 3.11-2 can be constructed entirely of wooden logs/limbs or bamboo. Larger logs are used for the corner posts and ceiling joists. A smaller size is used for the rafters, which are covered by a still smaller size laid at right angles. The sides of the enclosures are covered with lattice "doors" allowing air to move freely through the inside space, but keeping out animals and birds. The floor was compacted earth or was made of logs/bamboo.

This is a common shelter encountered in most third-world countries; it does not require skilled labor to construct. Trees or bamboo would be cut from the nearest source, trimmed, and carried to the site. Structural members would be nailed or tied together. A layer of large leaves, moss, clay or other native material would be placed over the rafters, before the roof logs are laid, to seal the roof. Two to four men typically could construct this type of enclosure in about one week. Material costs are estimated to be about \$300; local labor should be less than \$500.

3.11.4 Dispersed "Under-The-Array" Battery Housing Fig. 3.11-3

Clearly, with the exception of housing the batteries in a heated, (or air conditioned) well-insulated, ventilated building, it was difficult to visualize a cost-effective, locally built structure or kit that could efficiently augment the battery bank itself as an environmentally impervious barrier. Figure 3.11-3 depicts a configuration based upon this premise. The only vulnerable battery points are the electrical interconnects (external moisture, electrical leakage and hazard); and the porous ceramic filler tube, the Deltar caps, and the access port to the electrolyte lift pump (moisture, wind-blown dust and other contaminants).

Hughes has considerable experience with multicell batteries installed under the PV arrays. Precautions included raceways and conduit for the battery cables and protective shrouds for the cell-to-cell interconnects, plus protective cover for the fill tubes. Site ambient temperatures ranged from approximately 0 F to 110 F; environmental extremes included sandstorms, rainstorms and blizzards.

3.11.5 Recommendations

Hughes recommended that the dispersed under or the shadow of the arrays housings be adopted as shown in Figure 3.11-3. The battery deck is supported by transverse channels bridging the array structure. The battery terminals and fill tubes are also protected against wind-blown dust and snow by removable plastic covers. An acceptable cover design presently in use is fabricated from split PVC or ABS pipe. These light weight rugged covers are readily held down by plastic ties. The open construction and liberal intercell spacing provides excellent heat rejection and ensures that potentially damaging hot spot temperature rises will not occur in the electrolyte. Increased panel mounting height will be required in equatorial sites to permit access to the strings for shallow panel inclination angles.

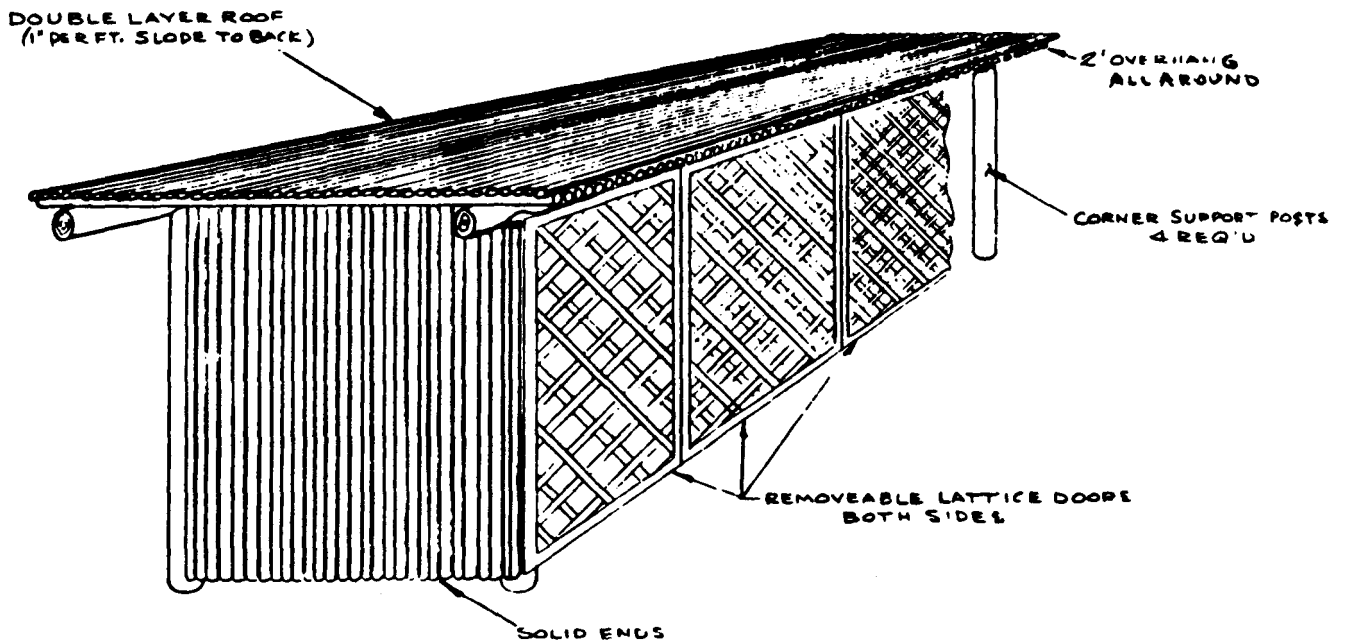

CENTRALIZED BATTERY ENCLOSURE -- ALTERNATE PREFAB FOR EQUATORIAL SITES
Figure 3.11-2

MODULAR SURFACE MOUNTED PHOTOVOLTAIC PANELS

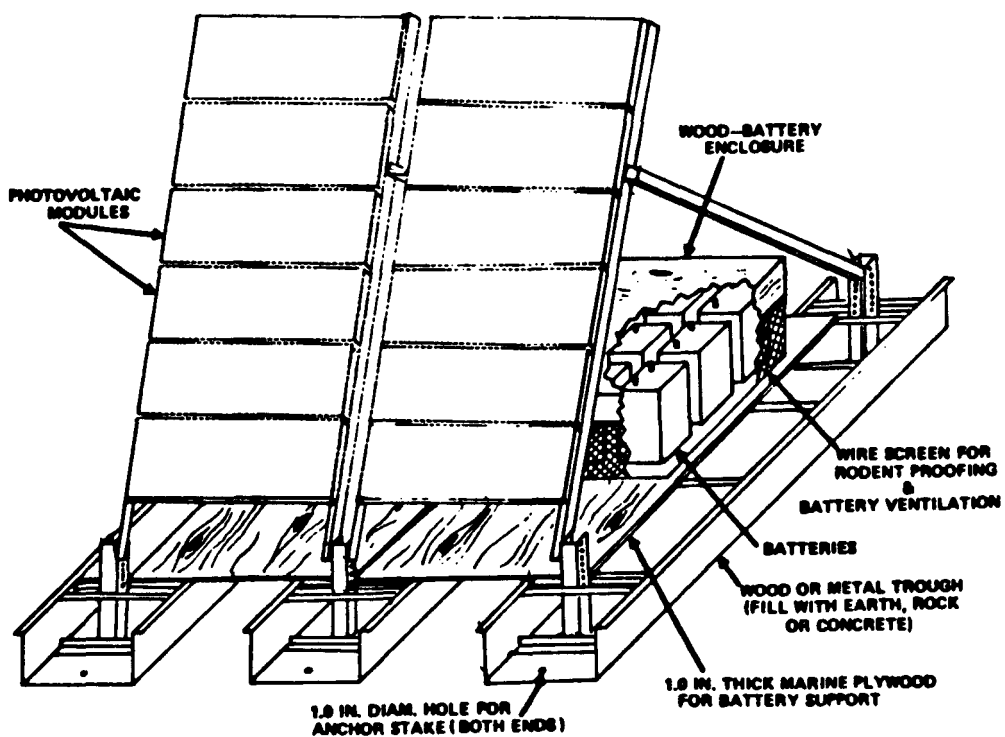

DISPERSED BATTERY ENCLOSURE
FIGURE 3.11-3

3.12 FIELD INSTALLATION AND OPERATIONS

3.12.1 General

These topics were identified as BOS elements. As appropriate, options were developed and evaluated under the Task I efforts. Certain trades, and alternative and recommended approaches, not previously discussed, are herein identified.

3.12.2 Transportation Considerations

Array Field Elements

This BOS subgroup included array structural and foundation elements, wire and cabling, and miscellaneous electrical and mechanical hardware. Our findings indicate that no specific restrictions exist with regard to mode of transport. Some level of factory preassembly or "kitting" was indicated.

Batteries

National and international carrier regulations required that "wet" batteries be shipped by surface transportation. For unusually remote sites it is recommended that alternative regional or geographical sources of supply be identified and verified as to their suitability. In unusual circumstances "Dry" batteries could be expeditiously shipped by air, with the corrosive electrolyte earlier forwarded separately by the approved surface or air transportation method.

Power Controller

Hughes recommends that the Power Controller be manufactured in the United States, in cost effective quantities, and shipped under the same conditions as other electrical/electronic apparatus. No special fragility appears to exist.

3.12.3 Installation

Our analyses indicate that quality manufactured BOS elements of mature design can be assembled in the field by semi-skilled labor. Competent technical supervision is, however, a mandatory prerequisite. Some of the techniques that add minimally to the manufacturing cost but reduced greatly the probability of installation errors included:

PV Modules

The shipment of thoroughly pretested modules, terminated in polarized Solarlok bus connectors, would eliminate most common electrical hook-up errors.

Array Structures and Foundations

These elements should be properly identified standard prefabricated parts; maximum use should be made of simplified structural drawings, or other illustrated breakdowns. The designer should follow good commercial kit assembly practices, not costly MIL-Spec procedures.

Array Field Wiring and Battery Interconnection

Layouts should be provided for all available standard ratings. Aerial-burial wire could lead to completely preassembled radial field cabling and/or even prefab aerial-burial harnesses. Battery cable using Supercon connectors could be partially assembled; the "Supercon" is not a difficult connector to field install. Essential trade skills include rudimentary electrical tasks (wire dressing, soldering, connector assembly, continuity testing and wiring-hypot with modules, not connected) and "pull" tests for mechanical integrity.

Power Controller

This BOS element must be a factory pre-wired assembly requiring only minor field adjustment, hook-up and functional check of electrical interfaces via the Solarlok/Supercon connectors; it requires only structural mounting on appropriate pad or pedestal.

3.12.4 Checkout and Commissioning

PC Array Power Collection Circuits

Daisy-chain wired branches facilitate rapid continuity testing and I-V pretest. Sequentially testing all individual branches and strings forming the particular rating can be done circuit by circuit with those power controller circuits activated.

Power Controllers

Regulator and protective circuits should be reasonably fail-safe with unambiguous displays of status provided. Simplified procedure must permit ready checkout of charge/regulation function. Pre-test and field calibration check may possibly be required.

Load Management Circuits

These circuits will depend upon correct assessment of battery state-of-charge; strong dependence upon complete factory pre-test for proper function is required.

Battery and Battery Circuits

After continuity, hypot, and other preliminary wiring integrity tests, the final checkout of batteries results from calibrated load tests.

Integrated System Performance

Full operation of system under various loads with varying degrees of array power contribution must be performed; also diurnal runs involving battery charge depletion are required. A simple but comprehensive acceptance test procedure (ATP) should make this effort quite straightforward.

3.13 Operations and Maintenance

On-Site Test Equipment and Tools Required

The following items are recommended: Electricians' and mechanics' tools, maintenance supplies, Portable DMM (digital multimeters), Hall current probes, Megohmmeter (hypot), Array Maintenance test set, battery hydrometers, and conductivity meter.

Routine Operations

The following functions appear to be required: Periodic check of system DC output; power flow (budget); relative contribution of array branches; absence of malfunctions or degraded performance. Checkout of battery electrolyte level and state-of-charge (S.O.C.) and all displays indicate in-tolerance operation.

Fault Diagnosis

These diagnostic capabilities appear to be required:

- o For array elements, isolation down to faulted string or branch, exhibiting a substandard power output.
- o For power controller, isolation down to faulted switching assembly, control board, or system control element.
- o For batteries, fault isolation to a malfunctioned (or substandard) string and within those, to a faulted cell or module.
- o For wiring/cable faults, isolation to individual radial power loops.
- o For faulted modules, string segmentation and faulted module identification using array maintenance test set.
- o For Load Management (LM) and load circuits, first load check and then test the individual load prioritization circuits, including the LM board and the battery S.O.C. sensors.

Maintenance Action

- o Replace faulted PV modules as necessary.
- o Replace faulted circuit boards.
- o Operate degraded battery strings at reduced power or shed faulted string (Battery spares are not recommended).
- o Replace faulted state-of-charge sensors.
- o Replace faulted temperature sensor.

3.14 SPECIFICATIONS, CODES AND STANDARD

3.14.1 General

The practices recommended and the hardware selected were examined carefully from the code standpoint. The standards that have provided baseline guidance are listed below. National standards, safety codes, and NEMA specifications are designed to ensure safe usage, protect personnel and to direct use of apparatus specifically suited for the particular functional requirement. Applicability of these documents is limited to those areas relevant to stand-alone photovoltaic power systems.

3.14.2 Major Codes and Standards Dealing with Personnel Safety, Protection of Electrical Power Systems, and Approved Apparatus

- A. ANSI C2-1981: National Electrical Safety Code (NESC).
- B. ANSI C1-1981: National Electrical Code (NEC/NPFC).
- C. NFPA No. 101-1976, Life Safety Code Public Law No. 91-596, Williams-Steiger Occupational Safety and Health Act of 1970 (84 Stat 1593, 1600; 29 USC 656, 657), Chapter XVII of Title 29 of The Code of Federal Regulations, established on April 13, 1970 (36 FR 7006), as amended through 1981.
- D. UL - Underwriters Laboratory, Inc. (Electrical Materials Construction Directory, May 1981).
- E. UL - Underwriters Laboratory, Inc. (Electric Appliance and Utilization Equipment Directory, May 1981).
- F. UL - Underwriters Laboratory, Inc. (Recognized Component Directory, Volumes I and II, Mar. 1981).

3.14.3 Related National Codes, Standards and Guidance Criteria Directed Toward Conventional Power Systems, but with Applicability to Stand-Alone Photovoltaics:

- G. IEEE Std 446-1980 (Orange Book), "Recommended Practice for Standby Power Systems for Industrial and Commercial Applications."
- H. IEEE Std 493-1980 (Gold Book), "Recommended Practice for the Design of Reliable Industrial and Commercial Power Systems."
- I. IEEE Std 242-1975 (Buff Book), "Recommended Practice for Protection and Coordination of Industrial and Commercial Power Systems."
- J. IEEE Std 141-1976 (Red Book), "Recommended Practice for Electrical Power Distribution for Industrial Plants."
- K. IEEE Std 241-19-74 (Grey Book), "Recommended Practice for Electrical Power Distribution in Commercial Buildings."
- L. IEEE Std 80-1976, "IEEE Guide for Safety in Subsystem Grounding."
- M. H.W. Denny, et al, Grounding, Bonding and Shielding Practices for Electronic Equipment and Facilities, Vol. 1, "Fundamental Considerations", AD-A0222332, Federal Aviation Administration Report No. FAA-RD-75-215, (Atlanta, Georgia Institute of Technology)

3.14.4 ANSI/IEEE/NEMA and DOE Codes and Standards Relating More to Specific Apparatus Classes

- N. MIL-A-90940 (ACG), "Specification for Lightning Arrestors."
- O. JPL/LSA 5104-164, "Interim Standard for Safety: Flat Plate Photovoltaic Modules and Panels."
- P. ANSI Committee C.I., "Lightning Protection Code/C62.1: Lightning Arrestors for AC Power Circuits."
- Q. ANSI C37.17-1972, "Trip Devices for AC and General Purpose DC Low-Voltage Power Circuit Breakers."
- R. ANSI C37.100-1972, "Definitions for Power Switchgear."
- S. IEEE Std 20-1973, "Low-Voltage AC Power Circuit Breakers Used in Enclosures (ANSI C37.13-1973)."
- T. NEMA AB1-1969, "Molded-Case Circuit Breakers."
- U. NEMA SG 3-1971, "Low-Voltage Power Circuit Breakers."
- V. NEMA No. pB 1.2-1977, "Application Guide for Ground Fault Protective

Devices for Equipment."

- W. IEEE Std 485-1978, "Recommended Practices for Sizing Large Lead Storage Batteries for Generating Stations and Substations."
- X. ANSI/IEEE Std 450-1975, "Recommended Practice for Maintenance, Testing, and Replacement of Large Lead Storage Batteries for Generating Stations and Substations."

4.0 CONCEPTUAL DESIGN OF STAND-ALONE MODULAR SYSTEMS

As indicated in the introduction of this report, the overall purpose of this effort was to develop/create a family of cost effective modular power systems with the approximate power range of 1 to 15 kWp that would be available for a wide variety of applications and environments. In consonance with this purpose, a systematic sequence of design tasks beginning with the conceptual design was performed to develop the final modular system design. The objective of this section is to describe the methodology used to develop the concepts that lead to the final modular design.

4.1 Conceptual Design Rationale

The general guidelines used in selecting appropriate concepts for the modular system were:

- 1) That the modular system be multi-purpose and applicable worldwide.
- 2) That the BOS components selected be mature and in a state of technical readiness ("off-the-shelf" and available for hardware testing in 1982).
- 3) That the system be designed for acceptance of Block IV modules being developed under the DOE National PV Program.
- 4) That the modular system incorporate the functional elements described previously on the BOS evaluation system.
- 5) That the System voltage be 120 volts DC.
- 6) That the selected concept is maximally cost effective over a minimum service lifetime of twenty years.

These guidelines effectively limited the selection of BOS components and hence, the module system to near term 1982 technology.

The design concepts, bounded by the above guidelines, were developed from the many options available in each of the BOS component categories identified in Task 1.

4.2 Environmental Specifications

The environmental specifications, shown in Table 4.2-1, were employed in all technical and economic evaluations during this design effort. These specifications are a modified version of the Basic Climate Zone Type 1 of Table 1, found in MIL-STD-210B "Climatic Extremes for Military Applications." It was determined that that the incorporation of extreme environmental conditions seriously impacted the design and cost of the modular system. On the other hand, deletion of the extremes did not limit the universality of the modular system application, because the extreme conditions represent a small portion of application sites for PV systems. For example, the snow load specification of 48 lb/ft² in the MIL-STD-210B is equivalent to the pressure exerted on a PV module by a snow pack of 10 ft.; the more realistic modified specification of 10 lb/ft² is equivalent to that of a 2 ft. snow level.

In the temperate zones, the battery is more vulnerable to electrolyte freezing (and subsequent destruction) when the daily insolation is low and the battery electrolyte heavily depleted at the end of discharge. Similarly, the battery should be derated 50 percent in expected operating life for each 15°F sustained electrolyte temperature rise above 77°F. The 0°F to 110°F ambient temperature limits are shaped by

environmental restrictions intrinsic to the battery, not by the other active BOS elements. Should systems be deployed to environments exceeding these temperature limits, special care must be afforded for battery protection.

Table 4.2-1. Summary of Modified Environmental Design Criteria for BOS Components

(1) Ambient Temperature	o o
Operating	0 F to 110 F
Storage	-25 ^o F to +120 ^o F (fully charged battery)
(2) Humidity	Up to 100%.
(3) Rainfall	0.0315 in/min.
(4) Snow-Blowing Snow	Up to 6.6×10^{-3} lb/ft ² /sec at 1.6 ft. above ground with a wind speed of 44 ft/sec.
Snow Loads	10^2 lb/ft .
(5) Ice Accretion	Up to 0.5" glaze with specific gravity of 0.9.
(6) Wind	Steady speeds to 77 ft/sec with gusts to 105 ft/sec.
(7) Dust	Concentrations up to 1.1×10^{-5} lb/ft ³ with most dust particles sizes 5.9×10^{-3} in. with wind speeds of 65 ft/sec. at 10 ft. above ground.

4.3 Baseline Conceptual Design Guidelines and Configurations

We established a baseline system (minimum power rating) configuration for each concept exhibiting the least system cost per kW-hr output for modular power levels from 1 kW to 15 kW. The electrical industry approach of equating a basic output, 1 kWp to a 1 Power Unit (P.U.) baseline output, was employed. A 16 kWp upper rating has been used for convenience, as have binary levels for standard power increments, namely 1, 2, 4, 8, 16. The availability of discrete power increments of less than 1 kW improve overall cost effectiveness. For example, if the stand-alone mission could be satisfied by a 1/2 PU photovoltaic array, the use of a 1 PU (1.0 kWp) field represents a costly, unnecessary expense. Accordingly, a single series array string delivering approximately 150 VDC at 2.13 ADC (320 Wp) will be available in one of the options.

The panel factors, that is, the peak standard current output required to support a specified continuous 24 hour load varies broadly from site to site when autonomous PV systems are deployed worldwide as various latitudes under a wide range of climatic conditions. Similarly, the storage factor, the kilowatt hour energy storage required to support a selected mission profile, is also highly site location dependent. For example, given identical 24 hour load demands, we find that a location such as Vancouver, British Columbia will require perhaps three times the panel output and four times the energy storage to obtain the same level of autonomy and "uninterruptibility" as an equivalent site near Albuquerque, New Mexico. As a means of establishing a "point of departure," we have somewhat arbitrarily adopted a panel factor of 7X, and a storage factor of 250 hours. This site corresponds approximately to a clear weather site in the southwestern desert regions of the United States.

4.4 Common Attributes and Characteristics

All conceptual design candidates have a number of common attributes; these are identified below.

4.4.1 Design Classification and Applications

The design tasks address stand-alone photovoltaic power systems in the range of 0.25 PU to 16 PU. Applications and uses include village power, pumping systems for water storage or irrigation, remotely located range operations, cottage industries, navigation aids, etc.

4.4.2 Environmental Design

The conceptual designs will satisfy the requirements of para 4.2 preceding.

4.4.3 Custom System Requirements

Designs of BOS elements specifically for arctic site applications (sustained gale force winds with snowfall, very low temperature--typically to -30°F, high probability of ice deposits, etc.) would be handled on an individual, site specific design basis.

4.4.4 Basic Electrical Configuration

The basic configurations will be monopolar with intermediate impedance ground reference on neutral leg. The min/max bus voltage limits will be a nominal 108 VDC to 162 VDC.

4.4.5 System Rating

One, two, four, eight and sixteen power units (PU) plus 0.25 and 0.5 PU incremental ratings below 1 PU (1.28 KW pk) is standard for all concepts. Combinations of any of the standards can be assembled.

4.4.6 Battery Storage

250 hours nominal carryover of autonomous storage (one battery string per power unit) has been selected.

4.4.7 Modular Expandability

- a) Batteries: replication of series strings of battery modules.
- b) Battery enclosures: batteries located under the PV array panels; dust covers on terminals; expansion under the extended array with increasing rating.
- c) Power controller: modularly expandable in one standard cabinet configuration up to 8 PU; from 9 PU to 16 PU, continue expansion in side-by-side identical enclosure with bridging main buswork; power control panel and all central control and decisional circuits do not have to be replicated from 8 PU to 16 PU.
- d) Foundations: on a panel/panel group basis; replicated as required.
- e) PV Panel Structures: replicated as required.
- f) Array field layout: replicated as required.
- g) Field wiring topology: radial topology replicated as required.

4.5 Panel Support Structures and Foundations

- (a) Level of factory assembly: prefabricated mechanical parts and subassemblies.
- (b) Source of materials: of U.S. origin, some BOS could however be procured/manufactured locally.
- (c) Site preparation requirements: basically a level site with no major protuberances or outcroppings.
- (d) Site soil restrictions: minimal with the post hole and planter ballast foundation options.
- (e) Assembly and installation methodology: minimum special or field or custom engineering.
- (f) Labor and on-site materials requirements: unskilled labor with trained supervisor; earth or rocks for planter ballast.

Alternative foundation designs are fully compatible with stated functional and environmental specifications. Installations have to survive a twenty year service life.

4.6 Array Field Layout and Wiring Topology

4.6.1 Physical Installation and Layout

Once the required foundation approach has been selected, and the system power level established, each of the alternatives available for the physical installation should not disproportionately impact upon the cost and complexity of the balance of the system. For example, all installations require a clear unshaded area with about twelve feet minimum spacing between rows. Some sort of perimeter security is needed to protect the system, as well as errant personnel. The level of protection required is site specific, but does not vary from concept to concept.

4.6.2 Field Wiring Topology Options

Our selected options included the "octopus," daisy-chaining, and tapered ampacity busing/trunking. Common requirements included twenty year survivability, the highest dielectric integrity, less than 1 percent wiring power losses, electrical and environmental protection, and minimum maintenance requirements.

4.6.3 Battery Enclosure or Protection

Dispersed battery strings installed on a channel supported deck in the north shadow of the array rows is the recommended enclosure concept.

4.7 Power Controller Electrical Configuration

4.7.1 General

This major BOS element has the following general attributes:

- (a) Plug-in printed circuit boards, relays and mother board on power control panel.
- (b) Ready access to control circuits and elements.
- (c) Status indicating LEDS and readily available test points for diagnostic purposes.
- (d) Ability to isolate, quick disconnect, and sectionalize battery strings as well as load distribution circuits.
- (e) Fault current trip with contingency back-up.
- (f) Diode blocking of bus current backflow into faulted PV branches; isolation of batteries.
- (g) BUS lines are fused in each battery string; battery fuse box is an isolated NEMA 3R enclosure, physically separated from controller.
- (h) All power control contactors will be the hermetically sealed mercury displacement type, protected by appropriate power snubbers.
- (i) The output bus will feed a minimum of four prioritized distribution circuits or feeders.
- (j) Each output feeder will be controlled by a load management contactor and can be disconnected by a manual circuit breaker.
- (k) Deltar S.O.C. sensors will be used to energize the four comparator channels on the load management P.C. board.

4.8 Energy Storage

4.8.1 General Battery Specifications

- (a) Service class and/or battery type: Industrial quality Pb-Ca with options for tropical or cold weather service.
- (b) Kilowatt Hours Store (approx.): 30 kWhr per 1 PU pk baseline at 25°C.
- (c) Ampere-Hours Stores (approx.): 250 AH to 275 AH @ 25°C, 8 hour rate.
- (d) Max. Permissible Discharge Depth: 15-20 percent daily energy extraction limit recommended for typical recurrent usage; limited number of deep discharges (to 80 percent) permissible.
- (e) Number of Cells per String: 60 individual 2 volt nominal cells.
- (f) Nominal Battery Bus Voltage: 120 Vdc @ 2 volts per cell, 25°C.

4.8.2 Notes and Definitions

The following definitions apply:

- o Cell: Lowest individual power increment; three or more plates per cell, for lead acid, nominally 2 volts per cell.
- o Multicell battery module: A building block containing 2 or more cells in a factory assembled package; usually called a "module."
- o Battery string: An electrical string of a number of single or modular packages hooked up in series for attaining the desired bus voltage.
- o The battery: complete battery subsystem.

4.9 Electrical Protection

4.9.1 Degree of Sectionalization

The modular approach adapts very well to functional sectionalization. It appears beneficial both to critical load support and to reduction of lifetime energy costs to be able to take a faulted portion of the system off-line and perform the necessary maintenance, while the balance of systems is still generating power. Automatic sectionalization in the event of a malfunction is not recommended; for example, it would not be cost effective to provide the complex on-line diagnostics to sense an out-of-specification series module string and disconnect it automatically from the power collection net. In the quasi-constant voltage subsystems, the battery and load circuits, fault sectionalization is inherent because of breaker trip and fusing coordination.

4.9.2 Lightning Protection

The several options include a description of proposed lightning rod configurations; the presently preferred design is an aerial counterpoise and simple towers. Deletion in regions of low isokeraunic activity is also a recommended option. No overhead array is required when taller adjacent structures exist.

4.9.3 Buried Metallic Counterpoise

The general method of burying a metallic counterpoise in trenches carrying the power collection cabling has been adopted as the most cost effective approach; 1/4" galvanized wire, buried to approximate 22" depth, has been used. The configuration of the lightning rods and buried metallic counterpoise(s) are somewhat site specific; the same approach was adopted for each of the option candidate approaches.

4.9.4 Voltage Limitation

Voltage limitation is required to protect the BOS elements against the damaging effects of abnormal electrical transients. The important parameters include the type and location of varistors and joule discharge capabilities. These protective elements remain substantially the same for all conceptual design options. Metallic oxide varistors (MOVs) without supplemented gaps are used. One shunt RC snubber across each power unit input is recommended as an EMI safeguard.

4.9.5 Equipotential Bonding

Separate equipotential bonding straps are recommended only if the mechanical metal-to-metal contacts are suspect, and in circumstances where physically separated array structures have to be interconnected and grounded with an acceptably low resistance, preferably not in excess of 30 ohms.

4.9.6 Ground Fault Relaying (GFR)

Hughes recommends that the ground fault relay be provided for the array field as a whole. GFR sensitivity should be in consonance with the DC-"LET-GO" current magnitude per Dalziel; all branch circuits are to be crowbarred simultaneously at the Power Controller inputs. All options are to be treated identically.

4.9.7 Transverse Mode Fault Relaying

Principal protective elements are the load circuit breakers, battery fuses, undervoltage trip, and blocking diodes in the array circuits. All options are handled identically. A transverse mode fault on the load side is required to trip the circuit breakers. Service cannot be restored until safe fault-free operations are assured. Branch input circuit breakers serve principally as safety disconnects; fault trip levels will never be reached except under very low probability of simultaneous diode and array shorting faults.

4.9.8 General Safety

Other electrocution hazards, protection against the arcing fault, and installation security are the same for all options. Essentially all of the requirements and attributes of an adequate electrical protection plan, beneficial to minimizing lifetime energy costs and essential to twenty year system survivability, have been uniformly applied to all options.

4.9.9 Codes and Standards

The NFPA, UL listings and approvals, and NESC, NEC, NFPC, OSHA, NEMA, and ANSI codes apply equally to all options.

4.9.10 Operations and Maintenance

Field skills required, frequency of maintenance actions, the ratio of scheduled to unscheduled maintenance, difference of maintenance action times for various BOS elements, and the spread in random failure rates were examined. These parameters are considered to be equivalent for all options.

4.10 Conceptual Design Candidates

4.10.1 General

The generic conceptual designs considered in this study are shown in Figure 4.10-1. The systems selected are based upon the general guidelines limiting the design development to technology readiness by 1982 and to those options uncovered in Task I which appear to offer the most promise for low cost, and possible future reduction in cost, and technology advancements. As shown, a number of alternatives exist in wiring topology, foundations, batteries, regulation and load management. For areas, such as modular structures, electrical protection, site preparation, and security the lowest cost standard approach was adopted; and the selection becomes basically "optionless." Selection of some of the options are site specific (e.g., foundations options) while other selections may be determined by the load profile (e.g., battery option or load management option). In any case, it is apparent that the options are independent of each other and may be substituted without major impact to other options. Thus, the number of combinations of options making up the generic modular design concept was very large, and to a major degree unmanageable in the original unscreened form. The ultimate program goal was to develop and converge on an optimally cost-effective modular configuration. It was first necessary to employ engineering judgmental processes and apply the results of earlier life cycle costing to reduce the number of options to a manageable level. This was done, and a more than sufficient number of practical, real system configurations were identified. During the process of concept development we looked for special interactions that might in some way result in a uniquely superior concept. None was observed; in general, the cost and performance benefits (as well as the shortfalls) of the individual BOS options extended uniformly to all alternative concepts.

4.10.2 Design Concepts

Seven design concepts are characterized in paragraphs 4.10.2 thru 4.10.9 and their respective figures. Attributes common to all concepts are as follows.

On-Line Instrumentation

On-Line displays will be limited to low power LEDs indicating regulator mode and unsafe or out-of-tolerance operating conditions. The status of the prioritized buses will also be shown. Total bidirectional battery current will also be indicated on a small analog meter.

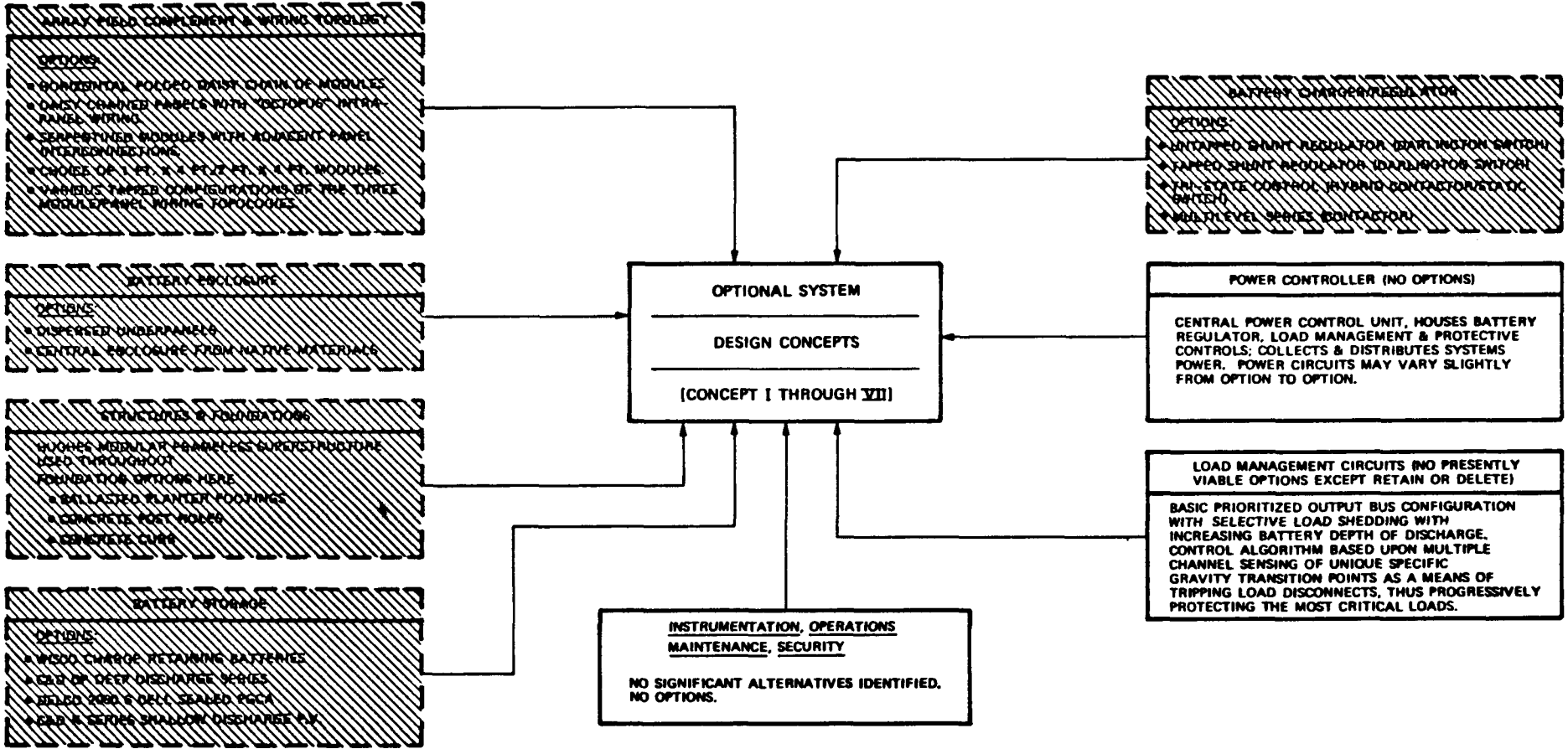

SELECTED BOS OPTIONS AND ALTERNATIVES FOR CONCEPTUAL DESIGN OF BASELINE I.P.W. P.V. SYSTEM.

FIGURE 4.10-1

Off-Line Diagnostics

Maintenance items include a) an analog multimeter, b) digital multimeter, c) a hall current probe, and d) a module maintenance test set plus miscellaneous tools and fixtures.

Array Support (Superstructure)

The Hughes modular frameless panel support is universally deployed in all concepts.

Electrical Protection

Metallic Oxide Varistors (MOVs) will be used in an equivalent manner throughout. All options include the cost of a Ground Fault Relay (GFR); it simultaneously trips all array crowbars in the event of a common mode fault between the positive bus and ground. Battery strings will be fused individually in both the positive and negative lines. Load faults will trip the corresponding prioritized circuit breakers. Diode/RC snubbers will be provided on all power contactors; capacitive snubbers will be employed on circuit breakers.

Load Management Circuits

Deltar sensors will be employed to measure the specific gravity of selected cells for the purpose of determining battery state-of-charge. Four trip levels will be provided at 20 percent, 40 percent, 60 percent, and 80 percent of battery full charge. These levels correspond to the four sequentially prioritized load buses on the output panel which are controlled by the load shedding and pickup contactors. These features are common to all alternatives.

Power Controller

While three charger regulator concepts are employed, the general electrical and mechanical configuration remains relatively constant. A single eight power unit (8 PU) console has been selected as the standard. Apart from the particular regulator circuit evaluated, all power contactors, as required, will be of the hermetically sealed mercury displacement type. The heat sinks required in the solid state options are considered integral to each conceptual approach.

Site Security

A standard 5 ft. perimeter fence with access gate would be deployed in all options.

4.10.2 Design Concept I Summary (Figure 4.10-2)

- (a) PV modules: Standard 2 ft. x 4 ft. modules, 64 watts pk nominal.
- (b) Panels: Accommodates up to 4 ea. 2 ft. x 4 ft. modules.
- (c) Power: 1.28 kWp (1 PU) nominal with 640 kWp branches.
- (d) Wiring topology: Monopolar, 1.28 KW folded daisy chain.
- (e) Regulation: Untapped shunt regulator with power darlington switches.
- (f) Structure/Foundation: Hughes modular frameless with planter feet.
- (g) Batteries: 200 AH Wisco sized for 1.28 kWp.
- (h) Battery enclosure: Dispersed, 12 cells under each panel.

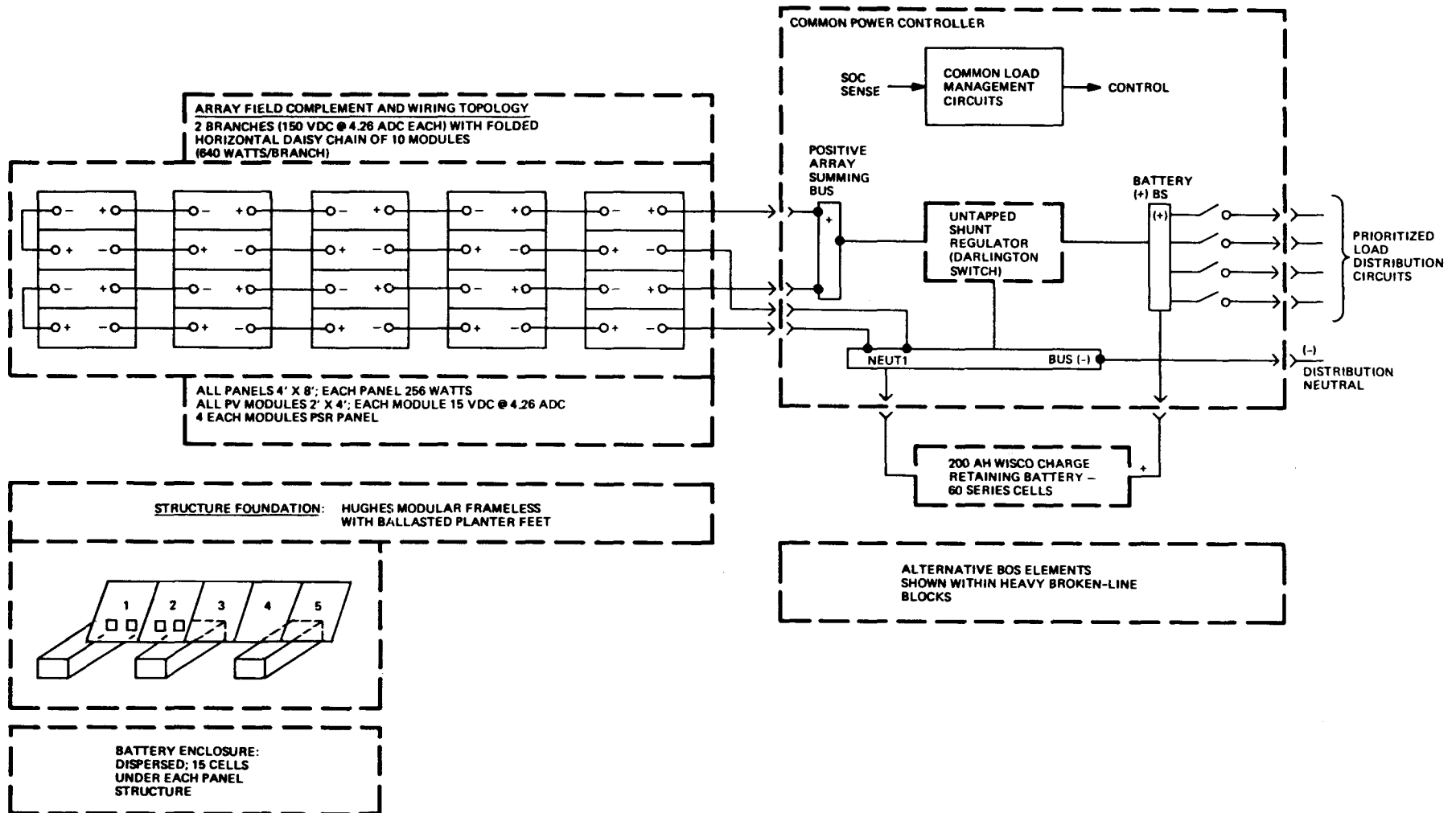

Figure 4.10-2 - Design concept I baseline IPU PV system.

4.10.3 Design Concept II Summary (Figure 4.10-3)

- (a) PV Modules: 2 ft. x 4 ft. standard modules, 64 Wpk nominal.
- (b) Panels: Accommodates up to 4 ea. 2 ft. x 4 ft. modules.
- (c) Power: 1.28 kWp (1 PU) with 640 Wp branches.
- (d) Wiring topology: Monopolar, octopus. Folded horizontal daisy-chain with 640 watt peak branches.
- (e) Regulation: 50 percent tapped shunt solid state with Darlington switches.
- (f) Foundation: Concrete curb footings.
- (g) Batteries: C & D QP series, 60 series cells, QP-5-45; strings separately fused.
- (h) Battery Enclosures: Central enclosure from native material.

4-14

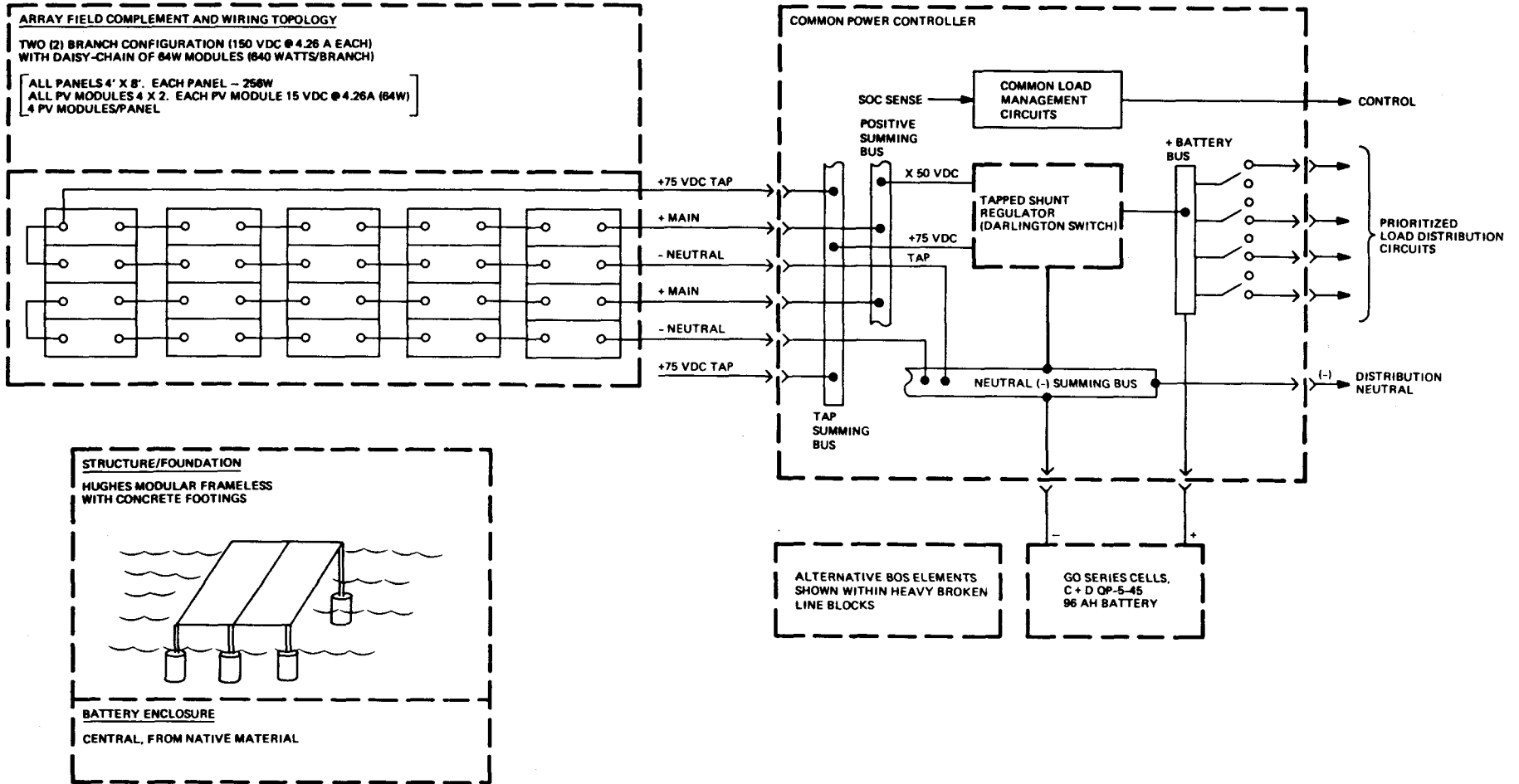

Figure 4, 10-3 - Design concept II baseline IPU PV system.

4.10.4 Design Concept III Summary (Figure 4.10-4)

- (a) PV Modules: 1 ft. x 4 ft. standard modules, 32 Wp.
- (b) Panels: Accommodates up to 8 ea. 1 ft. x 4 ft. modules.
- (c) Power: 1.28 kWp (1 PU) nominal.
- (d) Wiring Topology: Monopolar each of 5 (series) panels octopus wired for 30 volts.
- (e) Regulation: untapped shunt, using Darlington power transistor.
- (f) Structure/foundation: Hughes modular frameless/concrete post footings.
- (g) Batteries: 260 AH, C & D 3KCPSA5, 60 series cells; 3 cells per battery module; strings separately fused.
- (h) Battery enclosures: Dispersed, 15 cells under each panel.

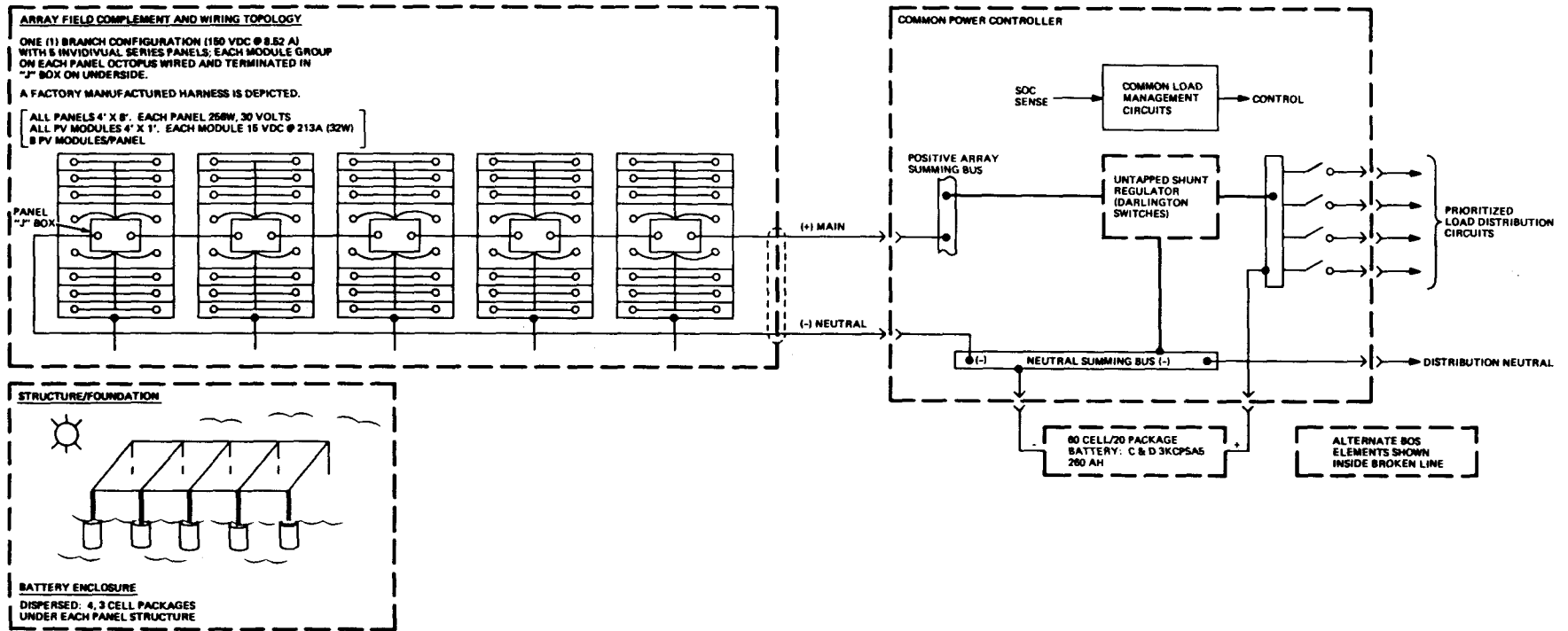

Figure 4. 10-4 - Design concept III baseline IPUS.

4.10.5 Design Concept IV Summary (Figure 4.10-5)

- (a) PV Modules: 1 ft. x 4 ft. standard modules, 32 Wpk nominal
- (b) Panels: Accommodates up to 8 ea. 1 ft. x 4 ft. modules.
- (c) Power: 1.28 (1 PU) kWp.
- (d) Wiring Topology: Monopolar each of 5 (series) panels octopus wired for 30 volts.
- (e) Regulation: Untapped shunt, using darlington power switch.
- (f) Structure/foundation: Hughes modular frameless concrete post footings.
- (g) Batteries: Basic module: Delco 2000, 12 volt, 100 AH (6 series cells) battery; 2 in parallel for each of 10 series blocks for a total of 20 batteries. 120 ea. 2 volt cells; strings separately fused.
- (h) Battery enclosures: Dispersed, 2 ea. - 10 cell modules under each panel.

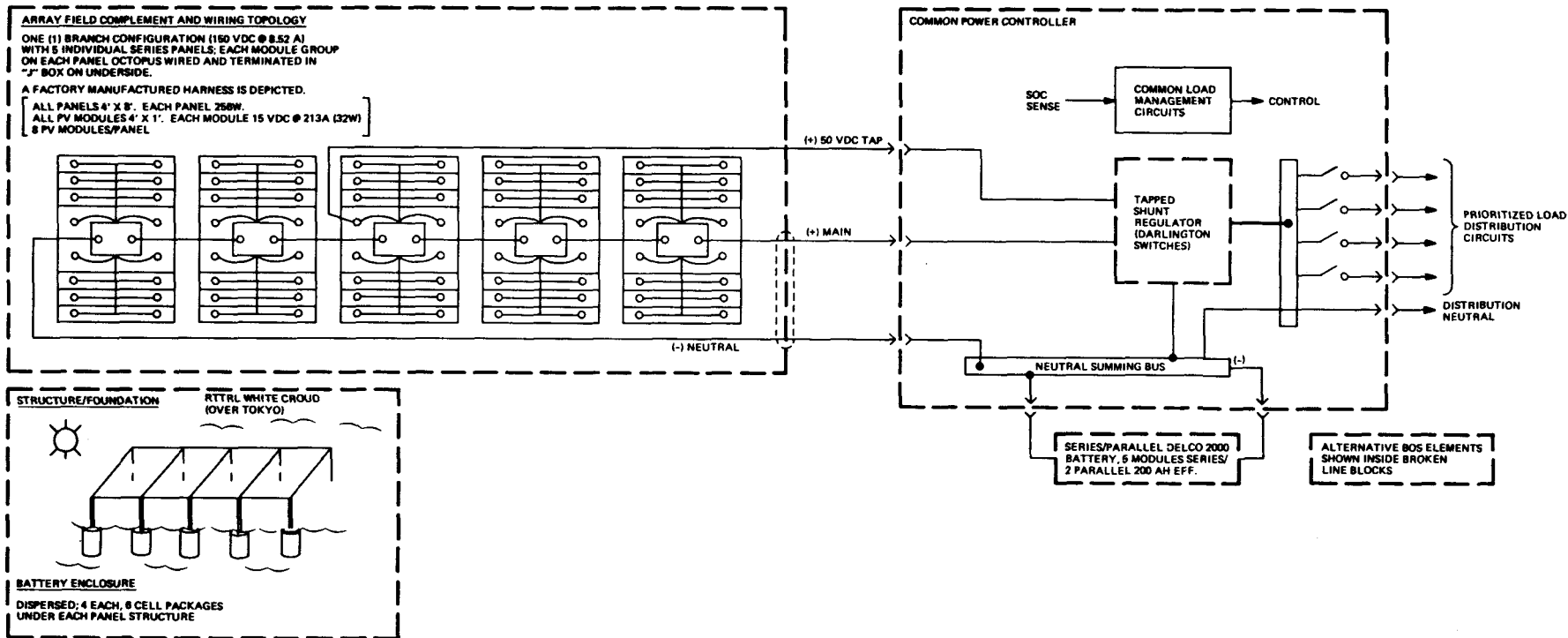

Figure 4.10-5 - Design concept IV baseline IPU PV system.

4.10.6 Design Concept V Summary (Figure 4.10-6)

- (a) PV modules: 2 ft. x 4 ft. standard modules, 64 Wp.
- (b) Panels: Accommodates up to 4 ea. 1 ft. x 4 ft. modules.
- (c) Power: 1.28 (1 PU) kWp.
- (d) Wiring topology: Monopolar, horizontal folded daisy-chain, with split branches and voltage tap.
- (e) Regulation: Hughes tri-state control.
- (f) Structure/Foundation: Hughes modular frameless/concrete post footings.
- (g) Batteries: Basic Module: Delco 2000, 12 volts, 100 AH battery, (6) series 2 volt cells per unitized battery, two 2000 series batteries in parallel for each of 10 series blocks; 20 batteries total (120 ea. 2 volt cells).
- (h) Battery Enclosures: Dispersed, 4 each 6 cell batteries under each panel.

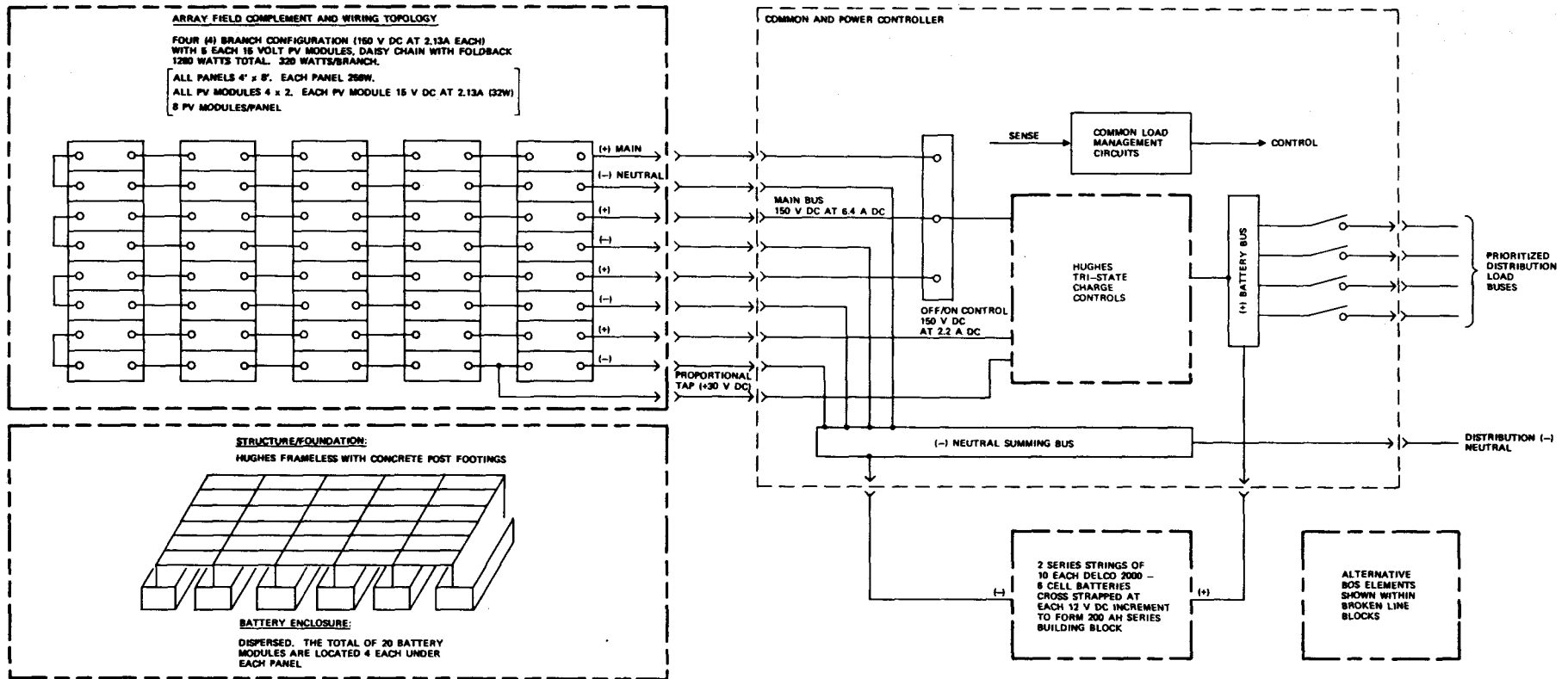

Figure 4.10-6 - Design concept V baseline 1 PU PV system.

4.10.7 Design Concept VI Summary (Figure 4.10-7)

- (a) PV Modules: 2 ft. x 4 ft. standard modules, 64 Wp.
- (b) Panels: Accommodates up to 4 ea. 2 ft. x 4 ft. modules.
- (c) Power: 1.28 (1 PU) kWp. - (1 PU).
- (d) Wiring Topology: 2 branch configuration; each branch consists of 10 modules in series to form a folded daisy chain generating 150 VDC @ 4.26 ADC
- (e) Regulation: Multilevel series control using hermetic mercury displacement relays; each of two branches dedicated to a control channel.
- (f) Structure/foundation: Hughes modular frameless/concrete post footings.
- (g) Batteries: 260 AH, C & D 3KCPSA-5, 60 series cells; or 20 battery modules one string separately fused.
- (h) Battery enclosures: Dispersed, 5 battery modules under each panel.

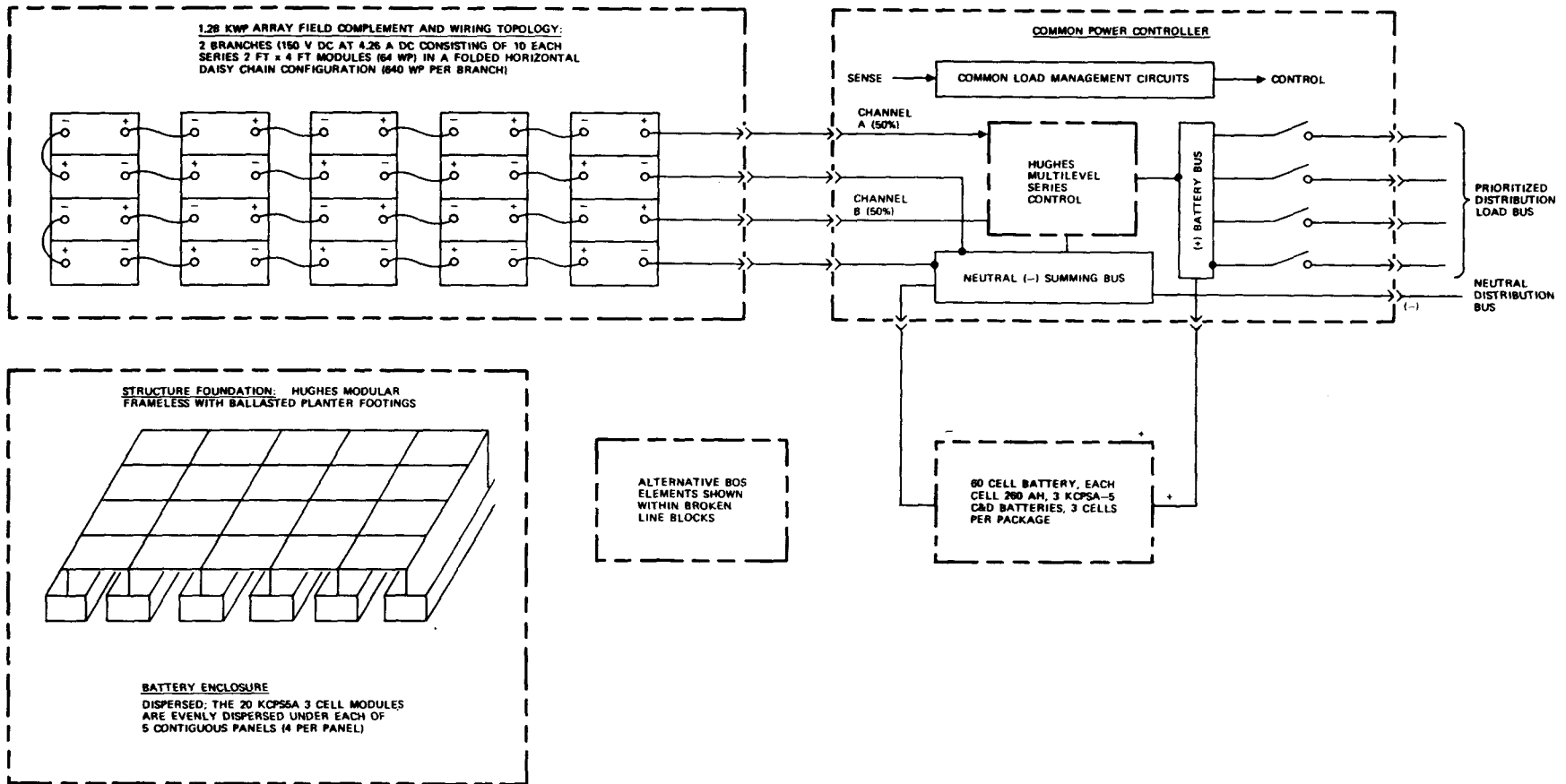

Figure 4. 10-7 - Design concept VI baseline 1 PU PV system.

4.10.8 Design Concept VII Summary (Figure 4.10-8)

- (a) PV modules: 1.6 ft. x 4 ft. standard module, 51 Wp.
- (b) Panels: Accommodates up to 5 ea. 1.6 ft. x 4 ft. modules.
- (c) Power: .512 kWp (150 VDC @ 3.4 ADC)
- (d) Wiring topology: Each of two panels vertical series daisy-chain of 5 1.6 ft. x 4 ft. modules, two panels @ 75 Vdc each serpentine to give 512 Wp (1/2 PU).
- (e) Regulation: 50 percent Tapped Shunt regulator using power darlington transi.
- (f) Structure/foundation: Hughes modular frameless/ballasted planter feet.
- (g) Batteries: Basic Module: Delco 2000, 12 volt, 100 AH battery, each 6 series 2 volt cells; Battery: 10 Delco 2000 battery modules in series (60 ea 2 volt cells) for 120 VDC/100 AH.; each string separately fused.
- (h) Battery enclosures: Dispersed, 15 batteries under each panel.

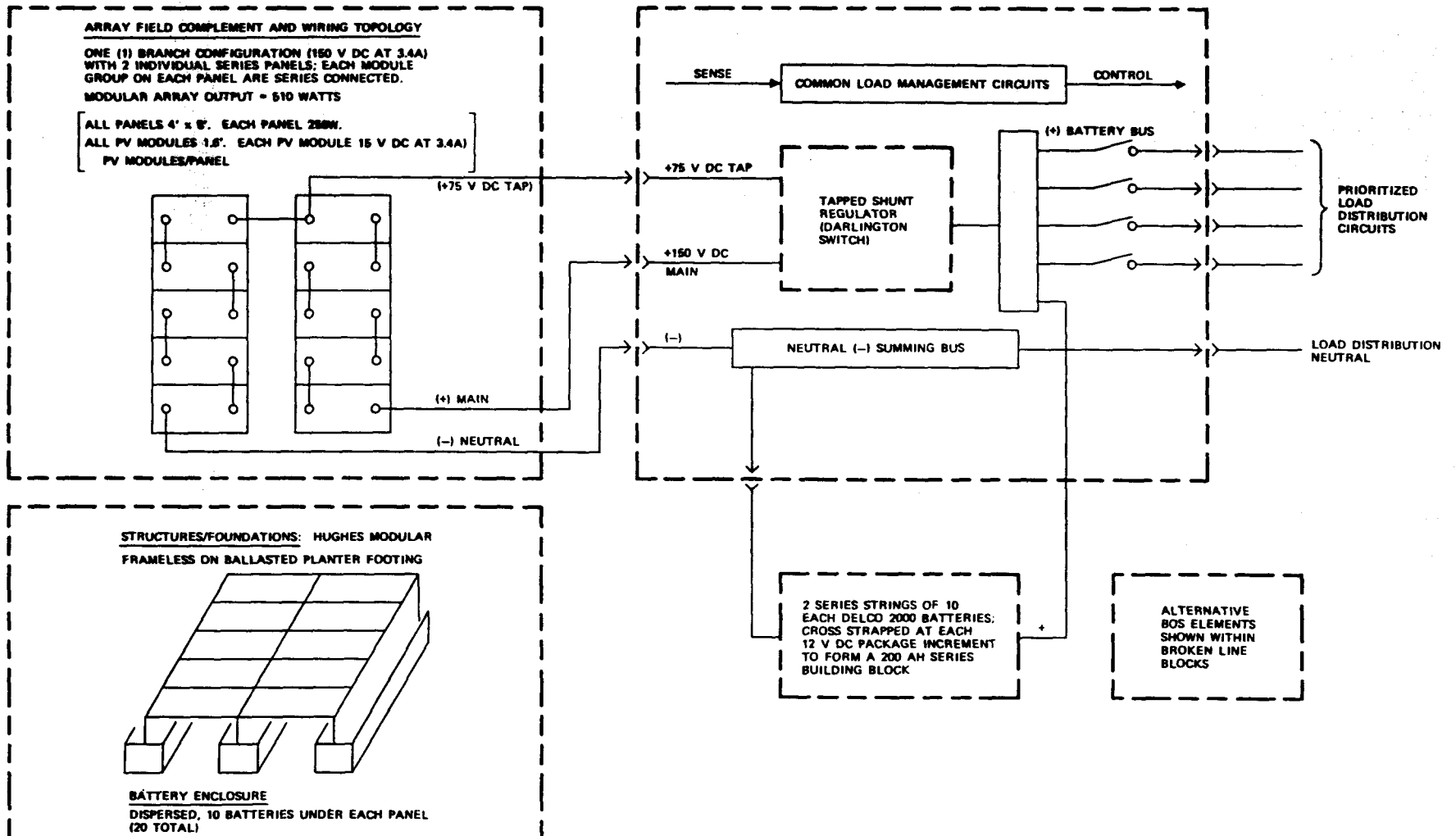

Figure 4.10-8 - Design concept VII 1/2 PU baseline PV system.

4.11 Summary of Characteristics

The characteristics of each of the seven (7) alternative conceptual designs are summarized in Table 4.12-1 following.

4.12 Hughes Recommendations for Three Preliminary Design Candidates

4.12.1 Surviving Candidates

Based upon the economic and technical evaluation, Hughes recommended at the Preliminary Design Review meeting three design approaches (of the original seven) that merit further development. Table 4.13-1 following tabulates these recommendations; the paragraphs following summarize the selection rationale.

4.13 Rationale for Final Selection and LCC Determination

4.13.1 Electrical/Array Wiring Configurations

4.13.1.1 System Concepts V & VI of Table 4.13-1

The electrical design concepts of the folded horizontal daisy chain were selected because of array wiring simplicity and branch circuit orientation. The horizontally interconnected branch circuits minimize shading losses in the larger systems (as compared to the octopus or vertical serpentine) when multiple rows of modules are used. The folded horizontal daisy chain, when interconnected with SOLARLOKS, also precludes the need for remote J-boxes. This low-cost concept was also the only configuration which used multiple branch circuits to modularly build up the array module power level. This feature was compatible for application with the tri-state regulator, the tapped shunt regulator, and particularly the Hughes multilevel series control. This concept is equally applicable to the 1/4 PU (320 WP) and the 1/2 PU (640 WP) ratings. Fewer panel supports would be used in these fractional ratings, and the modules would be wired in serpentine similar to Concept VII.

4.13.1.2 System Concept VII of Table 4.13-1

The 512 watt array module concept depicted by electrical design concept No. VII was recommended as this concept represented the smallest array module power increment available. It could be cost effective in meeting fractional power requirements down to 1/2 PU. This concept advantageously used the serpentine daisy chain configuration to minimize array wiring and installation costs. It was also compatible with the tapped shunt regulator, since 15 volt increments were available for optimum tap selection.

4.13.2 Batteries

The Delco 2000 and the C & D 3KCPSA batteries were selected for three system concepts listed in Table 4.12-1, thereby eliminating Wisco and the Deep Discharge QP C & D batteries. The Wisco charge retaining battery was rejected primarily because of the uncertainty in load profiles to which a general purpose stand-alone PV system might be subjected. While the Wisco battery is an excellent choice for applications with a near constant load demand, the battery must be substantially derated to satisfy higher discharge rates that, in turn, are needed to satisfy other applications.

Table 4.12-1. Comparison of Modular PV System Concepts

	<u>System Concepts</u>						
	I	II	III	IV	V	VI	VII
<u>WIRING TOPOLOGY</u>							
1.2 KW Horizontal Daisy	X		X		X	X	
1.2 KW 30 V Octopus		X		X			
.5 KW 75 V Daisy							X
<u>REGULATOR/CONTROLS</u>							
Shunt	X	X					
Tapped			X	X			X
Tri State					X		
Series EM Multilevel						X	
<u>INSTRUMENTATION AND DIAGNOSTICS</u> Standard for All Concepts							
<u>ELECTRICAL PROTECTION</u> Standard for All Concepts							
<u>STRUCTURE/FOUNDATION</u>							
Planter	X					X	X
Curb		X					
Cement Footing			X	X	X	X	
Rock Mount							
<u>SITE PREPARATION AND SECURITY</u> Standard for All Concepts							
<u>BATTERIES</u>							
500 AH WISCO	X						
C&D QP Series		X					
Delco 2000				X	X		X
C&D 3KCPSA-5			X			X	
<u>BATTERY ENCLOSURE</u>							
Dispersed	X		X	X	X	X	X
Tropical Prefab Central							
Dry Wall Slab Central							
Native Mat Central							
<u>LOAD MANAGEMENT</u> Standard for all concepts							

Table 4.13-1. Recommended Conceptual Designs
 PHOTOVOLTAIC STAND-ALONE MODULAR SYSTEMS:
 Three Conceptual Design Recommendations

<u>SUBSYSTEM</u>	<u>DESIGN CONCEPT</u>		
	V	VI	VII
<u>Wiring</u>			
1.2 kW Daisy	X	X	
0.5 kW-75 V Daisy			X
<u>Regulation/Control</u>			
Tri-State	X		
Tapped Shunt			X
Series Multilevel		X	
<u>Batteries</u>			
Delco 2000			X
C&D (3KPSA-5)	X	X	
<u>Battery Enclosure</u>			
Dispersed	X	X	X
<u>Instrumentation & Diagnostics</u>	BASIC	BASIC	BASIC
<u>Electrical Protection</u>	BASIC	BASIC	BASIC
<u>Site Prep & Security</u>	BASIC	BASIC	BASIC
<u>Structures</u>			
Ballasted Planter		X	
Post Hole	X		X
<u>Load Management</u>	BASIC	BASIC	BASIC

The C & D Deep Discharge QP series photovoltaic system battery was rejected because of high cost. This battery, designed for daily deep discharges, can represent an overdesign for many stand-alone photovoltaic systems. It, or equivalent electromotive batteries, would, however, be essential if 80 percent discharge were required on a daily basis.

The Delco 2000 battery was recommended for use with System VII. Ten of these batteries made up a battery module of nominally 100 AH at 120 volts. At the 1 PU (1 KW pk) level, each of the 10 series blocks consisted of two paralleled Delco 2000s, yielding a basic 200 AH module. This configuration represented a reasonable increment for satisfying the modular concept of battery storage. This battery offered the minimum initial acquisition costs and life of approximately three years. Depending upon site location, the overall life cycle cost of this battery appeared to be higher than the longer life C & D battery. The C & D battery 3 KCPSA-5 was recommended for system concepts V and VI. Twenty of these 6 volt batteries represented a battery module exhibiting approximately 260 AH of storage. This "shallow discharge" battery appeared to have the required properties to satisfy stand-alone service and excellent service life, estimated to be at least seven years when protected against overcharging and related stresses. This battery offered the lowest life cycle cost.

4.13.3 Regulators/Controls

The three surviving approaches recommended were the tapped array shunt regulator, the Hughes Tristate controls, and the multilevel LM series controls. The manufacturing costs of the three designs were comparable, with the tapped regulator slightly favored. The electrical interface of the tristate control with the array module was slightly more complex due to the requirement for the series tap and parallel division. The Hughes multilevel control required only that the parallel branch circuits be appropriately partitioned at the array inputs. Compensation circuits on either regulator were required to adjust the battery float voltage for ambient temperature. Incremental or multi-state control was clearly favored for improved battery longevity.

4.13.4 Battery Enclosure

Dispersed battery enclosures were used in concert with the post hole footings or the ballasted planter to utilize the battery weight as array ballast and to use the shade of panels to help cool the batteries. An additional benefit derived by dispersing the batteries under the panels was using the steel battery rails as alignment fixtures to hold the panel support stanchions during the post hole filling or the planter alignment operation.

4.13.5 Instrumentation and Diagnostics

Each of the recommended conceptual options was based upon minimal built-in, or online, instrumentation. Go/No Go status indicators and a bipolar (zero centered) DC ammeter are recommended for inclusion in the final design.

4.13.6 Electrical Protection

All of the options provided means for protecting personnel against accidental contact between exposed array "hot" and ground and back to neutral or (-). A 10 kilohms power resistor tying system neutral to ground at a single central point is included. This system limits the common mode current flow through errant personnel to about 15mA DC at maximum array voltage. This value is below the worst case Dalziel "Let-Go" current level. As a safety backup, however, an active ground fault relaying circuit, initiating total array crowbaring, was also incorporated. Circuit costs were uniformly applied to all system options.

Potentially damaging overcurrent as the result of load faults is first interdicted by the load circuit breakers. The HVDC battery fuses provide contingent and coordinated fault trip. The costs of these protective sensing and relaying circuits were included in all options. The expected reduced down-time, reduced subsystem damage and perforce lower life cycle costs were indeterminate and therefore were not factored into the LCC determinations.

4.13.8 Structures/Foundations

The post hole footing was chosen as one of the two foundation concepts that best satisfied the requirements of this study. An equally favored concept was the ballasted planter. Digging the post holes was considered a universal skill, and therefore, amenable to the use of indigenous labor. It was felt that, in areas where concrete is not obtainable, the post hole could be dug deeper, the stanchion made longer with a pad attached to its bottom, and the hole filled with local dirt or rocks and followed by tamping.

During the conceptual design phase, structures using the Hughes ballasted planter footing designs were built and installed at NWC China Lake as part of FPUP contract. This concept was advanced during Task I; at that time it did not look too attractive, principally because of the higher estimated factory labor and material content. As it turned out, the ease and installation simplicity of these designs far exceeded expectations; the planter concept was subsequently included as a final design option.

4.13.7 Site Preparation and Security

Site preparation requirements were minimum with the post hole footing and the ballasted planter. Preparation consisted primarily of shrub and bush removal, and, as necessary, minor excavation to prevent potential panel interference. The security fencing included in the LCC cost estimates was minimal, consisting of a five foot galvanized farm fence.

4.14 Life Cycle Cost (LCC) for Conceptual Designs

Life cycles cost estimates on the seven initial conceptual design options including the rationale, guidelines, and assumptions relevant to these analyses were developed. An existing LCC computer program named FLEX was developed by Hughes for use on other government projects. Routines and equations of this program were used (some slightly modified) to develop the LCC data base and summaries for each of the conceptual designs, preliminary designs, and the final design.

4.14.1 Description of Reports

For each of the ten conceptual designs under investigation, three inflated and discounted (cost of money) life cycle cost reports were generated

<u>Report No.</u>	<u>Description</u>	<u>Output Units</u>
1.0	Cost Breakdown Structure	1981 \$ Percentage of total
2.0	Cost Breakdown Structure	1981 \$ Dollars per watt
3.0	Cost Breakdown Structure	1981 \$ per year (twenty years)

4.14.2 Guidelines and Assumptions

To ensure accurate and uniform costing comparisons among the ten systems, guidelines and assumptions used are enumerated below.

(a) General

1. All manufacturing drawings are complete - no additional design engineering required.
2. Preproduction proof of design models have been built and verified; systems are ready for production.
3. The manufacturing facility is a factory dedicated to the production of photovoltaic power systems.
4. System is designed to survive at least twenty years.
5. There are no market distribution costs; systems are sold direct to the user.

(b) System Size Differences

The system under consideration fell into two different power ratings: 0.512 kWp and 1.280 kWp.

To lessen the cost effects due to these size differences, the 0.512 kWp system was costed by combining two 0.512 kWp array modules to form a 1.024 kWp system. Because slight size difference remained between the two categories, subsystem components were sized individually for each category whenever possible. Some subsystems occurred in one size only and, consequently, the higher rated systems were favored. These subsystems are:

- (1) Power controller.
- (2) Electrical protection and safety.
- (3) Operation and maintenance.

(c) Life Cycle Costs (LCC) of Energy

The economic factors used to perform life cycle costs are listed below:

Annual System Operating Lifetime -	twenty years,
Annual Rate of General Inflation -	12 percent
Annual Escalation Rate for Capital Costs -	12 percent
Annual Escalation Rate for O&M Costs -	12 percent
Base Year for Constant Dollars -	1981
Annual Cost of Capital -	15 percent
First Year of Commercial Operation -	1981

(d) Labor and Material Costing Criteria

The above labor prices include labor base rates, overhead, G & A and a nominal profit of 10 percent, Material mark-up item (1) included G & A plus profit; (2) included material burden, G & A, and profit.

(e) Manufacturing Volume

For purposes of establishing optimum low LCC designs, an annual hardware production rate to satisfy a peak DC output of 1MW/year was assumed.

(f) Inflation and Discount Factors

The analyses reflected escalated (inflated) and discounted dollars and were generated from the following equation:

$$\text{Cost} = \sum_{n=1}^y \left(\frac{1 + i_n}{1 + d_n} \right)^n X(C_n)$$

Where: i_n = inflation rate = 12%

d_n = discount rate = 15%

n = year indicator

y = number of years in the life cycle = 20 years

C_n = cost element in 1981 dollars

Cost = total life cycle cost in inflated and discounted dollars

(g) Ground Fault Protection

Depending on site specific conditions ground fault protection is an option that need not be included in stand-alone PV power systems. Accessibility by unauthorized persons, physical security and protection, and other conditions unique to the local environment determine the necessity for this protection. When implemented into the system, the protection is estimated to cost about \$600.00 and is constant for all concept designs investigated.

(h) Load Management

Costs of load management were not included in the conceptual designs as the design of the load management subsystem was insufficiently developed at this stage of the study. Because this subsystem was common to all concepts, its omission did not impact evaluation of the various system concepts with regard to comparative cost effectiveness. It was costed during implementation of preliminary design phase.

4.14.3 Summary

Table 4.14-1 lists the total life cycle costs (dollars) and the specific life cycle costs per installed watt (dollars per watt) for each of the alternative conceptual system designs. The recommended configurations were V (tri-state regulator), VI (Series multilevel), and VII (tapped BJT Shunt). All three of the specific life cycle costs were dispersed less than 5 percent from the average; concept VI exhibited the lowest cost, but not to a significant degree. Systems jV and VI employ the regulators designs of the quasi-proportional or incremental type. Either of these features should result in battery service lifetime as well as reduction of stress on the control switching devices.

In the absence of long term relevant test data, no attempt was made to quantify this expected battery-life improvement and subsequent LCC savings. These savings could be significant as storage is by far the largest contributor to the BOS costs for the systems. In each case, considered storage costs represented about 64 percent of the total system cost. It was also concluded that reductions in system hardware requirements through applications of load management and acceptance of a specified load loss risk would result in significantly lower system initial acquisition costs and LCC.

Systems that used the lower cost, shorter life, Delco battery exhibited significantly lower initial acquisition costs that might be important for many users. The overall life cycle costs, however, were not significantly different from those systems using the longer life C&D battery.

Tables 4.14-2 and 4.14-3 provide summary costs of BOS elements for each concept. Tables 4.14.2A, 4.14.2B and 4.14.2C are copies of the Cost Breakdown Structure computer tabs for one system concept, tilted R-1. Computerized Cost Breakdown Structures were generated for all system concepts. A summary of the LCC for each system is shown in Table 4.14-1.

Table 4.14-1 System Life cycle Costing Summary

SYSTEM	LIFE CYCLE COST	
	TOTAL	\$/WATT
I(R1)	\$33,503	\$26.02
II	37,077	28.98
III	75,501	58.99
IV	35,434	27.71
I	28,526	27.85
VI	33,497	26.17
VII	35,808	27.98

TABLE 4.14-2

SUMMARY OF BOS ELEMENT TOTAL LIFE CYCLE COSTS IN DOLLARS

SYSTEM

ELEMENT	I	II	III	IV	V	VI	VII
1) ARRAY STRUCTURES AND FOUNDATIONS	323	618	442	454	363	454	454
2) SITE PREP/INSTALLATION	200	150	250	250	200	250	250
3) ARRAY AND POWER WIRING	475	294	741	324	195	310	324
4) POWER CONTROLLER	1937	1640	1640	1640	1640	1640	2088
5) BATTERY STORAGE AND ENCLOSURES	18466	23362	61269	22445	14989	18736	22445
6) ELECTRICAL PROTECTION AND SAFETY	1223	1223	1223	1223	1223	1223	1223
7) PERIMETER SECURITY	586	586	586	586	468	586	586
8) OPERATION AND MAINTENANCE	6044	6044	6044	6044	6044	6044	6044
9) TRANSPORTATION	4249	3160	3306	2468	3404	4254	2394

Note: Shipping costs are included in cost of each subsystem.

TABLE 4.14-3

SUMMARY OF BOS ELEMENT LIFE CYCLE COSTS IN \$/WATT

SYSTEM

ELEMENT	I	II	III	IV	V	VI	VII
1) ARRAY STRUCTURES AND FOUNDATIONS	0.28	0.48	0.34	0.35	0.35	0.35	0.35
2) SITE PREP/INSTALLATION	0.16	0.12	0.20	0.20	0.20	0.20	0.20
3) ARRAY AND POWER WIRING	0.25	0.23	0.58	0.36	0.19	0.24	0.25
4) POWER CONTROLLER	1.63	1.28	1.28	1.17	1.60	1.28	1.63
5) BATTERY STORAGE AND ENCLOSURES	14.24	18.25	47.87	17.53	14.64	14.64	17.53
6) ELECTRICAL PROTECTION AND SAFETY	0.96	0.96	0.96	0.96	1.19	0.96	0.96
7) PERIMETER SECURITY	0.46	0.46	0.46	0.46	0.46	0.46	0.46
8) OPERATION AND MAINTENANCE	4.72	4.72	4.72	4.72	5.90	4.72	4.72
9) TRANSPORTATION	3.32	2.48	2.58	1.96	3.32	3.32	1.87

5.0 PRELIMINARY DESIGN OF STAND-ALONE MODULAR SYSTEMS

5.1 Overview

Preliminary design was then effected on each of the three approved conceptual designs, Concept V, VI, and VII. Commercially available components were identified by model number. Preliminary designs were performed on hardware not commercially available, principally the electronic circuits and structural elements and structures. Each preliminary design was examined for maintainability. Plans and tests for demonstrating accomplishment of performance objectives were also developed. The economic assessments were also refined.

Further analysis of the three charger regulator options was accomplished; critical circuits were breadboarded and evaluated, and configurations were established, including provisional parts lists.

The other BOS elements that were subject to further design definition and refinement included array field wiring topology, electrical interfacing and interconnection, foundations, field layout and installation, battery environmental protection, and the overall power conditioning subsystem.

The modular expandability of the PV Array Field, the structures, and the batteries were found to be straightforward. The 1.2 kWp (1 PU) baseline array could be readily reduced in power by 50 percent (to 1/2 PU) by deleting one of the two ten-series-strings of 2 ft. x 4 ft. modules. Further reduction to 1/4 PU (320 watts pk), could be accomplished by substituting 1 foot x 4 foot modules (32 watts pk). Battery energy storage expansion by replication of the basic 20 module 3KCPSAa5 packages or the 20 series/parallel Delco 2000 for essentially ratings and site specific factors.

Additional analysis was done on the load management circuits, including the DELTAR Probes. The output load bus was prioritized in four discrete outputs, corresponding to a 80 percent, 60 percent, 40 percent, and 20 percent battery state-of-charge respectively. Each of DELTAR probes were dedicated to each to each of these transition points. The trip signal produced by the indicator ball sinking resulted in the opening of the prioritized load bus contactor. The preliminary design of the load management function was considered complete with the requisite incorporation into the overall control scheme.

5.2 Analytical Findings

In review, each of the three recommended conceptual designs appeared to offer individually a unique combination of superior attributes; also, in each case, the selected BOS elements integrated well into the overall system.

The pivotal elements of Concept V were the 1.2 kWp (1 PU) Daisy, the Tri-State Control and the C & D 3KPSA-5 Battery. Battery charging stress could be expected to be minimal; the tri-state regulator was modestly penalized as the result of additional complexity.

Concept VII could well be the favored configuration for fractional power unit ratings: the 1.6 ft. x 4 ft. (51 Wp) module is not the most popular industry configuration, and future procurement problems might be foreseen. The tapped shunt solid-state regulator, while straightforward, was a less favored choice

by virtue of more critical heat rejection requirements, increased battery charging stress, and less-than-optimal electrical safety isolation. Some residual uncertainty also existed regarding the ultimate cycle survivability of the Delco 2000 battery.

On balance, Concept VII, maintained the superior characteristics demonstrated by the other candidates, without exhibiting significant weaknesses. The Hughes multilevel charger is a reliable minimum charging stress design, expandable without circuit design modifications. It is likewise adaptable to fractional power unit ratings. The basic folded horizontal daisy in either the 320 Wp or the 640 Wp configuration is very easy to install and maintain, and it is modularly expandable to the ultimate degree. The judiciousness of selecting the C & D battery has likewise been well established.

5.3 Preliminary Design Review of Systems V, VI, and VII

The three recommended preliminary designs Concepts V, VI, and VII are described in the corresponding detailed system block diagrams, Figure 5.3-1 to Fig.5.3-6, respectively. The alternative BOS elements previously characterized are identified on each drawing. Interfaces are more fully defined, and baseline voltage and power levels are given.

Levelized lifetime bus bar energy costs of each system were developed under Task III of the project and reviewed during the PDR. This data are summarized under Para. 5.5.

5.4 Results of the Preliminary Design Review

5.4.1 Background

The Preliminary Design Review (PDR) meeting was held at NASA LeRC on November 28, 1981. As the result of that meeting, and the detailed technical evaluations by the NASA staff, Preliminary Design Concept VI was selected as that functional configuration most worthy of final design. This design features 2 ft. x 4 ft. modules daisy chained into 640 Wp array branches; the Hughes frameless structure with ballasted planter footings; the multilevel OFF-ON series control; and C&D KCPSA-5 multiple cell battery packages, installed under the array panels. In the several paragraphs following, a number of conclusions are given regarding the characteristics and the merit of the selected final design, both as an integrated system and from an individual BOS element viewpoint.

5.4.2 Array Structures and Foundations

The modular frameless panel is a straightforward design, economical to manufacture, and adaptable to various module widths and lengths. Field experience has shown that few (if any) installation problems are encountered.

The ballasted planter approach essentially frees the photovoltaic system installer from terrain peculiarities and variabilities. The method is readily installable on virtually any terrain and soil type, except steeply sloped monolithic rock, requiring anchorbolts or their equivalent.

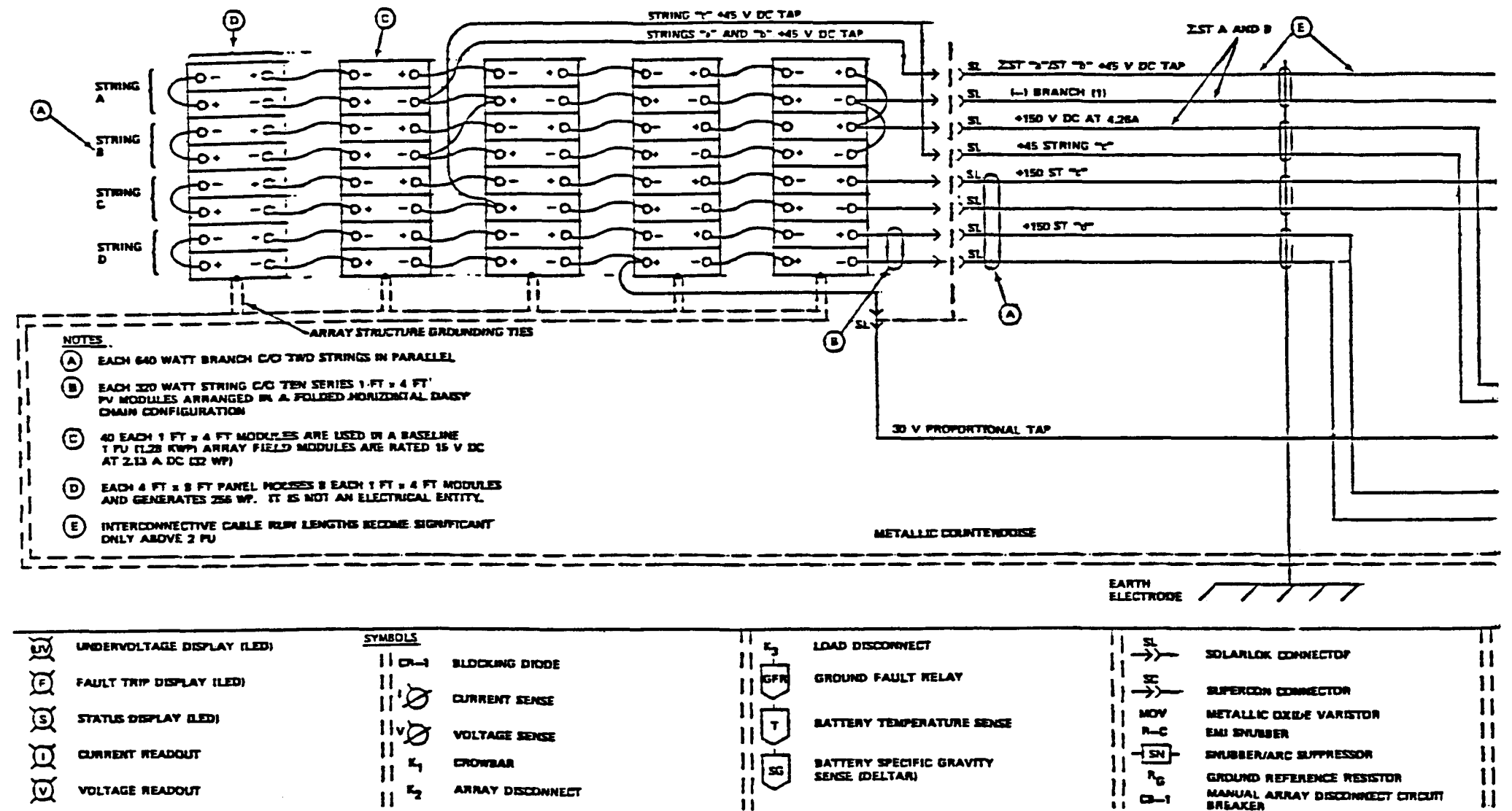
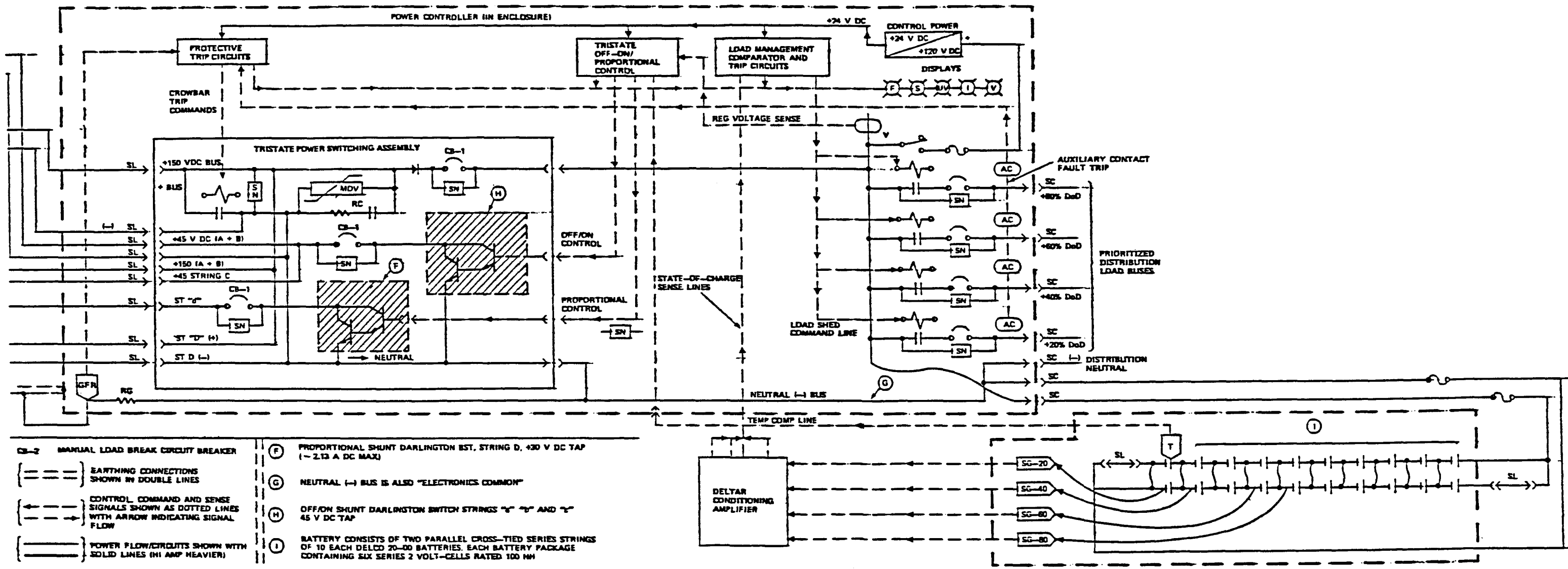

Figure 5.3-1 Preliminary design: system concept V, baseline 1 PU system.

Continued on the following page

Continued from the preceding page



- MANUAL LOAD BREAK CIRCUIT BREAKER
- ⊞ EARTHING CONNECTIONS SHOWN IN DOUBLE LINES
- ⊞ CONTROL COMMAND AND SENSE SIGNALS SHOWN AS DOTTED LINES WITH ARROW INDICATING SIGNAL FLOW
- ⊞ POWER FLOW/CIRCUITS SHOWN WITH SOLID LINES (HI AMP HEAVIER)
- (F) PROPORTIONAL SHUNT DARLINGTON EST. STRING D, +30 V DC TAP (~ 2.13 A DC MAX)
- (G) NEUTRAL (-) BUS IS ALSO "ELECTRONICS COMMON"
- (H) OFF/ON SHUNT DARLINGTON SWITCH STRINGS "b" "b" AND "b" 45 V DC TAP
- (I) BATTERY CONSISTS OF TWO PARALLEL CROSS-TIED SERIES STRINGS OF 10 EACH DELCD 20-00 BATTERIES. EACH BATTERY PACKAGE CONTAINING SIX SERIES 2 VOLT-CELLS RATED 100 MH

Figure 5.3-1 Concluded.

5-5 / 5-6

STAND ALONE SYSTEM RATING & POWER LEVEL	QUANTITY, COMPONENT AND CONFIGURATION OF SUB ELEMENT OR SUBSYSTEM: 0.25 PU - 10 PU											
	STRUCTURES AND FOUNDATIONS		PHOTOVOLTAIC ARRAY FIELD				BATTERIES		POWER CONDITIONING AND CONTROL			
	STRUCTURES	FOUNDATIONS	MODULES	PANEL	WIRING TOPOLGE	PACKAGING	ENCLOSURES	CHARGE CONTROLS	LR CONTROLS	POWER SWITCHING	ELECTRICAL PROTECTIENS	PACKAGING
0.25 PU (250 MW)	3 SUPPORT	6 CONCRETE FOOTINGS	5 PER PANEL; 10 TOTAL	2 PANELS; 100 W/ PER PANEL	SERIES UP-DOWN SERPENTINE	10 SERIES DELCO 2000 (1/2 STANDARD)	DISPERSED UNDER TWO PANELS	SHUNT 12 REGULATOR SUB-ASBY ONLY	STANDARD WITH 44 OUTPUTS	DARLINGTON SWITCH ONLY	STANDARD	SEE NOTE 12 IN 8 PU POWER CONTROLLED ENCLOSURE
0.5 PU (500 MW)	0	12	7 ON EACH OF 2 PANELS 6 ON THIRD; 20 TOTAL	3	SERIES PENNAPALLY TRANSVERSE SERPENTINE	10 SERIES DELCO 2000 (1/2 STANDARD MODULE)	EVENLY DISPERSED UNDER 3 PANELS	SHUNT 12 REGULATOR SUB-ASBY ONLY	STANDARD WITH 44 OUTPUTS	SAME AS ABOVE	STANDARD	SAME AS ABOVE
1 PU (1,000 MW) BASELINE SYSTEM	0	12	8 PER PANEL; 48 TOTAL	6	SERIES, FOLDED HORIZONTAL DAISY CHAIN 4 STRINGS 6 BRANCHES	STANDARD MODULE (20 SA NEVISE)	DISPERSED, 4 PER PANEL (6 PANELS)	STANDARD TRISTATE	STANDARD, 4 OUTPUTS	STANDARD PER (10)	STANDARD	SAME AS ABOVE
2 PU (2,000 MW)	11	12	8 PER PANEL; 96 TOTAL	10	SAME AS ABOVE WITH 11 BRANCHES	2 STANDARD MODULES (20 SA NEVISE)	DISPERSED, UNDER 10 PANELS	STANDARD, AS ABOVE	STANDARD, 4 OUTPUTS	3 CENTRAL ASBY PER (10)	STANDARD	SAME AS ABOVE
4 PU (4,000 MW)	21	48	8 PER PANEL; 192 TOTAL	20	SAME, WITH 10 STRINGS 6 BRANCHES	4 STANDARD MODULES (20 SA NEVISE)	DISPERSED UNDER 10 PANELS	STANDARD, SEE ABOVE	STANDARD, 4 OUTPUTS	3 ASBY PER (10)	STANDARD	SAME AS ABOVE
8 PU (8,000 MW)	41	96	8 PER PANEL; 384 TOTAL	40	SAME, WITH 22 STRINGS 10 BRANCHES	8 STANDARD MODULES (100 SA NEVISE)	DISPERSED UNDER 40 PANELS	STANDARD, SEE ABOVE	STANDARD, 4 OUTPUTS	3 ASBY PER (10)	STANDARD	SAME AS ABOVE
10 PU (10,000 MW)	51	120	8 PER PANEL; 480 TOTAL	50	SAME, WITH 26 STRINGS 10 BRANCHES	10 STANDARD MODULES (200 SA NEVISE)	DISPERSED UNDER 50 PANELS	STANDARD, SEE ABOVE	STANDARD, DUAL 4 OUTPUTS	DUAL 3 ASBY (10 TOTAL)	STANDARD	USE 2 EACH 8 PU PC ENCLOSURES

- NOTES
- ① MUSHIE STANDARD MODULAR FRAMELESS
 - ② CONCRETE FOOT FOOTINGS, RE. FOOT HOLES ACCEPTING BURIED FOOTING; GROUNDED INTO ASSURE RETENTION
 - ③ STANDARD 1 FT x 4 FT MODULES, 20 WP BOREL, 10 V DC AT 2.10 A DC
 - ④ PANEL CONSISTS OF 8 SA 1 FT x 4 FT MODULES
 - ⑤ HORIZONTAL FOLDED DAISY CHAIN, 20 WP STRUNG, 4 STRINGS PER 1 KWPK MODULAR INSTALLATION
 - ⑥ 20 SA DELCO 2000 BATTERIES/BASELINE 1 PU INCREMENT, 1 BATTERY MODULE CONSISTS OF 3 CROSS STRAPPED SERIES STRINGS OF 10 DELCOS EACH
 - ⑦ DISPERSED, UNDER THE PANEL
 - ⑧ MUSHIE TRISTATE CONTROL SUBSYSTEM
 - ⑨ SOB CONTROLLED LOAD RESISE STANDARD
 - ⑩ OFF/ON SHUNT DARLINGTON SWITCH PLUS PROPORTIONAL TRANSFER POWER CONTROL
 - ⑪ STANDARD 100V, CROSSBAR, BATTERY FUSES, DISCONNECT, AND UNDERVOLTAGE TRIP
 - ⑫ STANDARD 6 POWER UNIT POWER CONTROLLER ENCLOSURE
 - ⑬ THE 1R AND 10 PU RATINGS ARE INTERCHANGIBLE WITH THE MUSHIE TRISTATE OPTION; ONLY SHUNT OFF-ON SECTION CAN BE USED

MODULAR EXPANDABILITY CHARACTERISTICS: PRELIMINARY DESIGN OF CONCEPT V

FIGURE 5.3-2

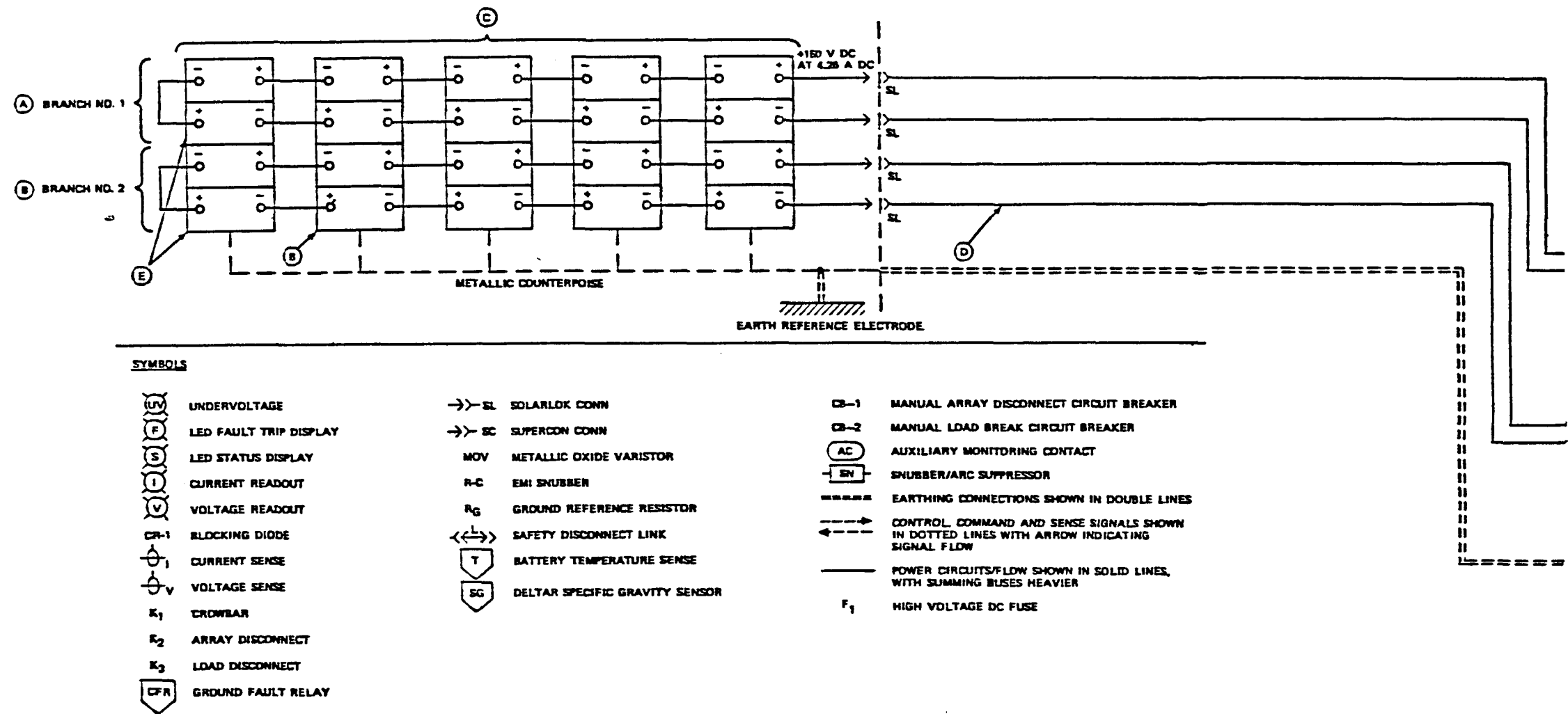

Continued on the following page

Figure 5.3-2 Preliminary design: system concept VI, baseline 1 PU (1.28 KWP).

Continued from the preceding page

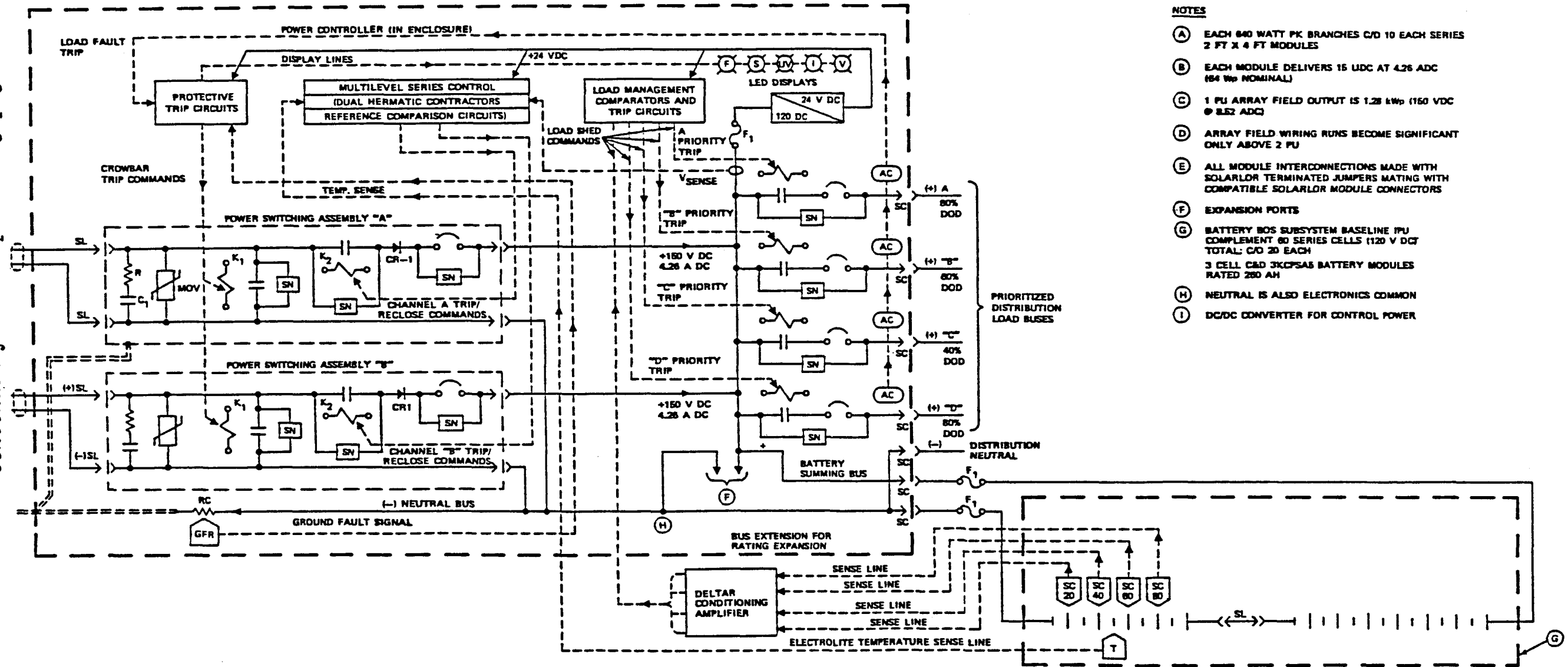

NOTES

- (A) EACH 640 WATT PK BRANCHES C/D 10 EACH SERIES 2 FT X 4 FT MODULES
- (B) EACH MODULE DELIVERS 15 UDC AT 4.26 ADC (184 Wp NOMINAL)
- (C) 1 PU ARRAY FIELD OUTPUT IS 1.28 kWp (150 VDC @ 8.52 ADC)
- (D) ARRAY FIELD WIRING RUNS BECOME SIGNIFICANT ONLY ABOVE 2 PU
- (E) ALL MODULE INTERCONNECTIONS MADE WITH SOLARLOR TERMINATED JUMPERS MATING WITH COMPATIBLE SOLARLOR MODULE CONNECTORS
- (F) EXPANSION PORTS
- (G) BATTERY BOS SUBSYSTEM BASELINE 1PU COMPLEMENT 60 SERIES CELLS (1120 V DCF TOTAL: C/D 20 EACH 3 CELL C&D 3KOPSAS BATTERY MODULES RATED 280 AH
- (H) NEUTRAL IS ALSO ELECTRONICS COMMON
- (I) DC/DC CONVERTER FOR CONTROL POWER

Figure 5.3-2 Concluded.

STANDARD SYSTEM RATING AND POWER LEVEL	QUANTITIES, COMPONENTS AND CONFIGURATIONS OF BDC ELEMENTS OR SUBSYSTEMS: 0.25 PU - 10 PU											
	STRUCTURES AND FOUNDATIONS		ARRAY FIELD			BATTERIES		POWER CONDITIONS AND CONTROL				
	STRUCTURES (1)	FOUNDATIONS (2)	MODULES (3)	PANELS (4)	WIRING TOPOLOGY (5)	PACKAGES (6)	ENCLOSURES (7)	CHARGE CONTROLS (8)	LM CONTROLS (9)	POWER SWITCHING (10)	ELECTRICAL PROTECTION (11)	PACKAGING (12)
0.25 PU (200 MW)	3 SUPPORTS	3 BALLASTED PLANTS	SEE BLEACH 1 FT x 4 FT (SERIES) OR 10U	2	SERIES UP-DOWN SEPARATE	20 EA SCOPAS (SERIES BATTERIES)	10 UNDER EACH OF 2 PANELS	SINGLE CHANNEL BEAMS CONTRACTOR	STANDARD NOTS PER (1)	ONE POWER SWITCHING ASSEMBLY PER (1)	STANDARD PER NOTS (1)	STANDARD PER NOTS (1)
0.5 PU (200 MW)	0	0		2	SERIES TRAVELER SEPARATE	20 EACH 3 SCOPAS (SERIES)	6 OR 7 UNDER EACH OF 2 PANELS	SINGLE CH WITH 2 FT x 4 FT MODULES, DUAL WITH 1 FT x 4 FT	SEE ABOVE	TWO FOR DUAL CHANNEL CONTROL	SEE ABOVE	STANDARD PER NOTS (2)
1.0 PU (200 MW) 0.25 PU (200 MW) SYSTEM	0	0	4 PER PANEL 20 TOTAL	0	SERIES HORIZONTAL FOLDED BUSH CHAIN	20 EACH 3 SCOPAS (SERIES)	4 UNDER EACH OF 5 PANELS	DUAL WITH 2 FT x 4 FT MODULES	SEE ABOVE	TWO FOR DUAL CHANNEL CONTROL	SEE ABOVE	SEE ABOVE
2.0 PU (200 MW)	10	11	4 PER PANEL 40 TOTAL	0	SAME AS ABOVE	TWO BASIC STRINGS IN PARALLEL (NO BATTERIES)	4 PER PANEL 10 PANELS TOTAL	DUAL CHANNEL	SEE ABOVE	2 PEA 80% PARTITIONED	SEE ABOVE	SEE ABOVE
4.0 PU (200 MW)	20	21	4 PER PANEL 80 TOTAL	0	SAME AS ABOVE	4 BASIC STRINGS IN PARALLEL (NO BATTERIES)	4 PER PANEL 20 PANELS TOTAL	DUAL CHANNEL	SEE ABOVE	4 PEA 80% PARTITIONED	SEE ABOVE	SEE ABOVE
6.0 PU (200 MW)	30	31	4 PER PANEL 120 TOTAL	0	SAME AS ABOVE	8 BASIC STRINGS IN PARALLEL (NO BATTERIES)	4 PER PANEL 40 PANELS TOTAL	DUAL CHANNEL	SEE ABOVE	8 PEA 80% PARTITIONED	SEE ABOVE	SEE ABOVE
10.0 PU (200 MW)	50	51	4 PER PANEL 200 TOTAL	0	SAME AS ABOVE	16 BASIC STRINGS IN PARALLEL (NO BATTERIES)	4 PER PANEL 80 PANELS TOTAL		OPTIMAL EXPANSION TO 8 CHANNELS ABOVE 6 PU	16 PEA 80% IN EACH 6 PU CABINET	SEE ABOVE	SEE ABOVE

- (1) HUGHES STANDARD MODULAR FRAMELESS
- (2) BALLASTED PLANTER UNIVERSAL FOOTING; NUMBER OF BALLASTED PLANTERS = $\frac{P_{TL}}{P_{PL}} + 1 + \frac{P_{TL}}{P_{PL}}$ WHERE P_{TL} = NUMBER OF PANELS
- (3) 2 FT x 4 FT MODULES HORIZ AT 4.50 A DC IN W PL EXCEPT AS NOTED
- (4) 4 FT x 8 FT STANDARD PANEL ASSEMBLY; EACH PANEL ACCOMMODATES 4 EACH 2 FT x 4 FT MODULES
- (5) HORIZONTAL FOLDED BUSH CHAIN OF TEN SERIES 2 FT x 4 FT MODULES, TWO END UP BRANCHES PER 5 PANELS ON 1 PU SAMPLE RATING
- (6) CMO SCOPAS BATTERIES; THREE SERIES CELLS PER PACKAGE, EACH CELL RATED 200 AH
- (7) DISPersed UNDER ARRAY, 20 BATTERIES PER 1 PU; BASELINE RATING; 4 BATTERIES INSTALLED UNDER EACH OF 5 PANELS
- (8) HUGHES MULTILEVEL SERVO REGULATOR; TWO CHANNEL CONTROL TO 500 W PL WITH 1 FT x 4 FT MODULES 1.20 KWP WITH 2 FT x 4 FT MODULES
- (9) STANDARD "BDC" CONTROLLED LOAD RUBER FOR PER ALL POWER LEVELS BELOW 6 PU
- (10) SERVO "OFF-ON" DUTY CYCLE CONTROL WITH HERMATIC BEHINDRY IMPACT/RESIST CONTRACTOR; ONE CONTRACTOR PER MODULAR POWER SWITCHING ASSEMBLY OR P.A.A.
- (11) STANDARD CROWBAR, BATTERY FUSE, LOAD/ARRAY DISCONNECT CIR, UV TEMPERATURE, ETC
- (12) STANDARD 6 PU POWER CONTROLLER ENCLOSURE THROUGH THE BATTERY; DUAL CHANNELS USED 6 PU THROUGH 10 PU
- (13) 10 PU BATTERY CHARGE IMPPLY MULTILEVEL CONTROL WITH 1 FT x 4 FT CE (BATT) MODULES MUST REVERT TO SINGLE LEVEL CONTROL

FIGURE 5-4 MODULAR ENERGY SYSTEM CHARACTERISTICS BY ENERGY W

FIGURE 5.3-4

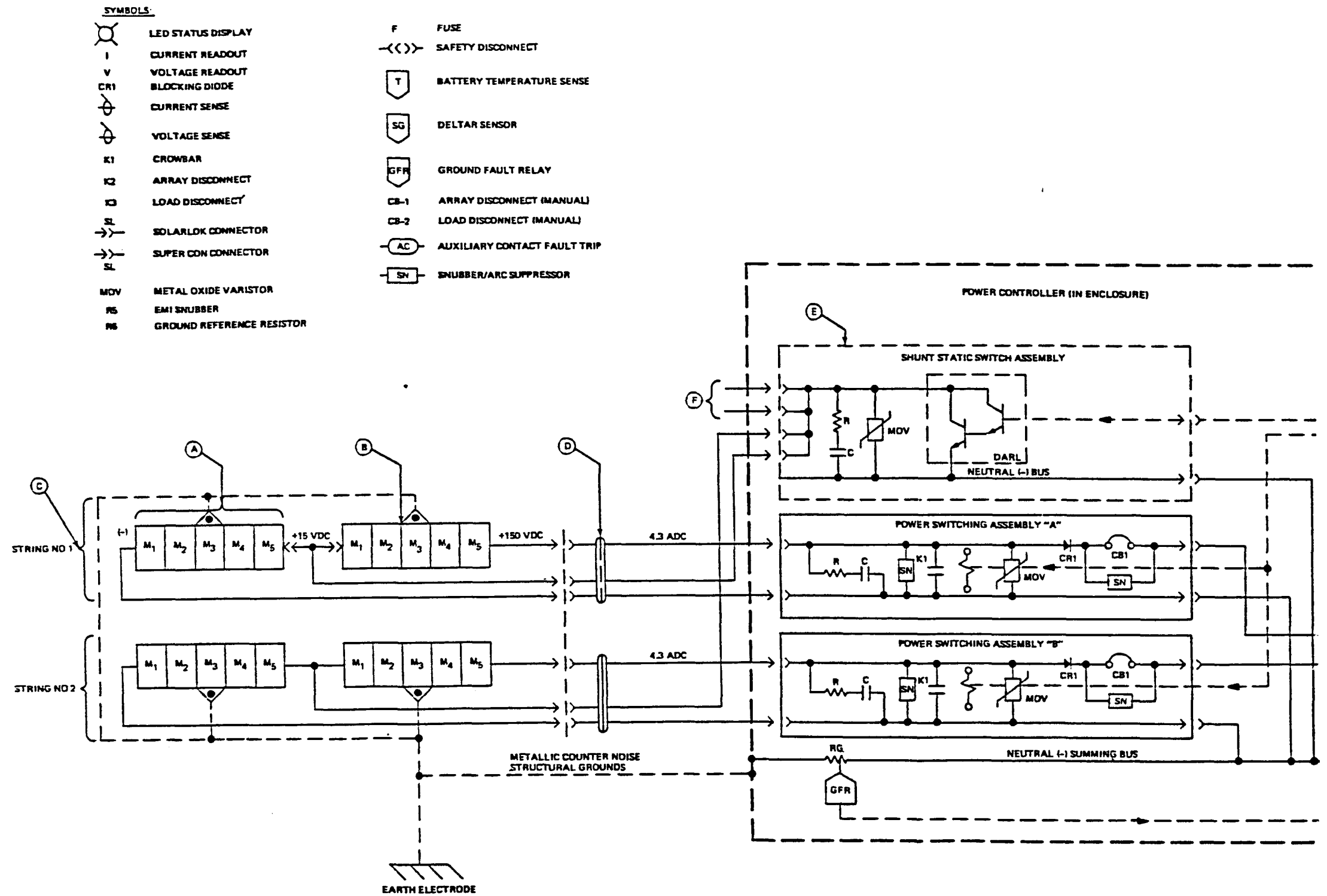

Continued on the following page

Figure 5.3-3 Preliminary design: system concept VII, baseline 1 PU system.

5-10
5-11(a)

Continued from the preceding page

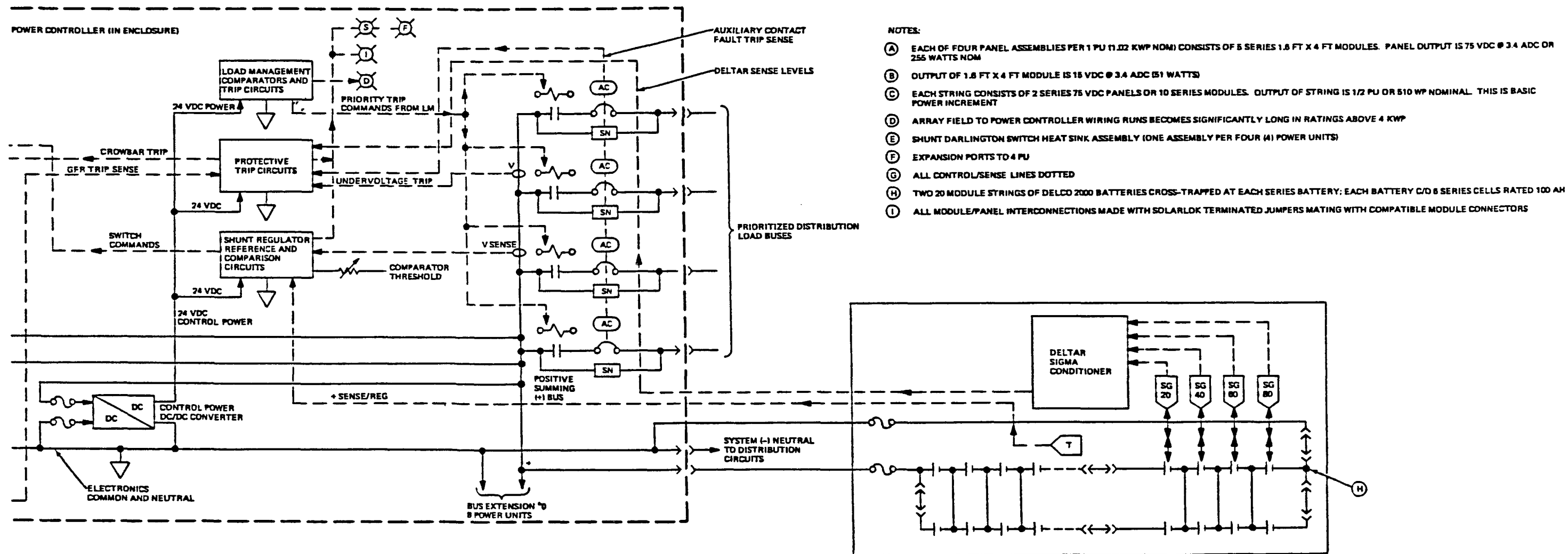

Figure 5.3-3 Concluded.

PRELIMINARY DESIGN RATING AND POWER LEVEL	QUANTITY, COMPONENT, AND CONFIGURATION OF ONE UNIT OR SUBSYSTEM: 0.5 PU (100W) TO 10 PU (10,000W) (1)													
	STRUCTURES AND FOUNDATIONS		PHOTOVOLTAIC ARRAY FIELD				BATTERIES					POWER CONDITIONING AND CONTROL		
	STRUCTURES AND PANEL SUPPORTS (1)	FOUNDATIONS (2)	MODULES (3)	PANEL (4)	WIRING TOPOLOGY (5)	PACKAGES (6)	ENCLOSURES (7)	CHARGE CONTROLS (8)	LM CONTROLS (9)	POWER SWITCHING (10)	ELECTRICAL PROTECTION (11)	PACKAGING (12)		
0.5 PU (100W)	3 SUPPORTS	0 POSTHOLES	10 EA. 04 WP	TWO PANELS 200 WP/PANEL	SERIES "UP-AND-DOWN" SEPARATING	20 EA. 6 CELL, DELOCO 2000	EVENLY SHUNT REG UNDER 2 PARCELS	TAPPED SHUNT REGULATOR AND DRIVER	STANDARD PER NOTE (1)	ONE PFA PER NOTE (2)	STANDARD PER NOTE (1)	IN 0 PU NEMA ENCLOSURE		
1.0 PU (200W)	0	10	20 EACH	FOUR PANELS	CONTINUED HORIZONTAL EXPANSION	20 EA. DELOCO 2000	EVENLY UNDER 4 PANELS ROW	IDENTICAL TAPPED REGULATOR AND DRIVER	PER NOTE (1)	ONE PFA PER NOTE (2)	STANDARD PER NOTE (1)	SAME AS ABOVE		
2.0 PU (400W)	0	10	40 EACH	EIGHT PANELS	SAME AS ABOVE	40 EA. DELOCO 2000	EVENLY UNDER 8 PANEL ROW	IDENTICAL TO ABOVE	PER NOTE (1)	2 PFA PER NOTE (2)	STANDARD PER NOTE (1)	SAME AS ABOVE		
4.0 PU (800W)	17	20	80 EACH	16 PANELS	SAME AS ABOVE	80 EA. DELOCO 2000	EVENLY UNDER 16 PANEL ROW	IDENTICAL TO ABOVE	PER NOTE (1)	4 PFA PER NOTE (2)	STANDARD PER NOTE (1)	SAME AS ABOVE		
6.0 PU (1,200W)	0	0	100 EACH	20 PANELS	SAME AS ABOVE	100 EA. DELOCO 2000	EVENLY UNDER 4 ROWS TOTALING 170 RUNNING FEET (2) PANELS	IDENTICAL TO ABOVE	PER NOTE (1)		STANDARD PER NOTE (1)	SAME AS ABOVE PU		
10 PU (10,000W)	0	100	200 EACH	80 PANELS	SAME AS ABOVE	200 EA. DELOCO 2000	EVENLY UNDER 8 ROWS TOTALING 80 PANELS (200 FEET)	IDENTICAL TO ABOVE	PER NOTE (1)	10 PFA PER NOTE (2)	STANDARD PER NOTE (1)	0 TO 10 PU USE DUAL 0 PU ENCLOSURES		

NOTES:

- (1) MEANS STANDARD MODULAR PANELS
- (2) CONCRETE POST FOOTING, I.E. POST HOLES ACCEPTING BURIED FOOTING; GROUTED IN TO ACHIEVE RETENTION
- (3) A STANDARD 1.5 FT X 4 FT MODULE, 16 VDC @ 2.50 AMP (41 WP)
- (4) PANEL CONSISTS OF FIVE EACH 1.5 FT X 4 FT MODULE; OUTPUT 200 WP
- (5) SERIES "UP-AND-DOWN" MEANS SPACING OF TEN MODULES, FIVE ON EACH OF TWO PANELS FOR STANDARD 0.5 PU (510 WP) RATING, 2 510 WP BRANCHES FROM THE BASELINE 1 PU (1020 KW) RATING
- (6) 20 EACH OF DELOCO MODEL 2000 BATTERIES FORM THE BASIC COMPONENT FOR THE 1 PU BASELINE DESIGN. BATTERIES ARE ARRANGED IN TWO IDENTICAL SERIES STRINGS OF 10 BATTERIES EACH. THESE STRINGS ARE PARALLEL ON BATTERY BUS. EACH DELOCO 2000 BATTERY (20) 5V X 8 SERIES PZC CELLS EACH RATED 100 AH. STRINGS ARE CROSSTIED AT EVERY BATTERY PAIR, PRODUCING A 100 CELL (120 VDC) BATTERY RATED 200 AH
- (7) BATTERIES ARE INSTALLED ON SUPPORT DOCKING UNDER THE PANEL ROW
- (8) TAPPED SHUNT REGULATOR FLOAT CYCLING BATTERY AS SPECIFIED END-OF-CHARGE POTENTIAL, VOLTAGE COMPENSATION FOR ELECTROLYTE TEMPERATURE CHANGES EMPLOYED
- (9) STANDARD STATE-OF-CHARGE CONTROLLED (REGULATOR BIASING) PRIORITIZED LOAD BUSES, UP TO FOUR OUTPUTS PER 0 PFA AVAILABLE
- (10) POWER SWITCH IN ACCOMPLISHED BY USE OF SATURATING DUAL ACTION SELD STATE SWITCH. ONE POWER SWITCH ASSEMBLY (PFA) PER 1 PU USED. SWITCHING ASSEMBLY COMPONENT 1 EXPANDED PROGRESSIVELY WITH INCREASED RATING. BASELINE DRIVER INCLUDED WITH (1) WALL. ACCOMMODATE UP TO 0 PU
- (11) STANDARD CROWBAR, LOAD AND ARRAY DISCONNECT CIRCUITRY FUSES, 60V, 4 SIM ENCLOSED, BATTERY UN TRIP, ETC.
- (12) STANDARD POWER CONTROLLER ENCLOSURE ACCOMMODATING UP TO 0 PU RATING USED; 10 PU SYSTEM EMPLOYS DUAL ENCLOSURES
- (13) THE SPACING OF 1.5 FT X 4 FT SERIES 16V VDC BRANCH (510 WP) CANNOT BE ASSEMBLED IN THE 0.5 PU RATING, 1 FT X 4 FT MODULES COULD BE USED TO OBTAIN A MINIMUM OF 200 WP. THIS ARRANGEMENT BECOMES ALMOST UNDESIRABLE FROM THE 0.5 PU RATING OF DESIGN V, WHICH ALSO USES A SHUNT REGULATOR FOR THE LEAST POWERFUL RATINGS

FIGURE 5-4. MODULAR SUBSYSTEM CHARACTERISTICS OF PRELIMINARY DESIGN CONCEPT V

FIGURE 5.3-6

5.4.3 Array Field Wiring and Interconnects

The folded daisy chain module/panel wiring configuration provides excellent modular sectionalization down to 640 wp (1/2 PU) incorporating 2 ft x 4 ft modules, and down to 320 Wp (1/4 PU) incorporating 1 ft x 4 ft modules. A symmetrical 2 PU array field, with a center/rear based power controller requires essentially no system wiring because all power collection and circuits terminate on the array center within about a two foot radius. Both extended and multiple row layouts also minimize run lengths and PV power losses as compared with other wiring methods. Both the Solarlok and the Supercon connection systems are rugged and reliable, well suited for photovoltaic applications.

5.4.4 Power Conditioning and Control

The series multilevel control was the final preferred method. All the final charge control concepts are excellent circuits. The tapped and untapped shunt Darlington switch regulators are straightforward and dependable; heat rejection requirements are more critical, and the multiplicity of heat sink assemblies required for the higher ratings cause some expandability problems. Both the Hughes tristate and multilevel controls minimize battery thermal stress and perforce and should extend battery life. The tristate controls are modestly penalized for reasons of undue complexity. The series control methods are optimally suited for these higher voltage systems. Using contactors as series pass elements is favored over static switches because of virtually zero heat rejection requirements and outstanding dielectric isolation. The use of the hermetically sealed mercury displacement relay, with snubbers, should ensure that the specified twenty year service life goal can be met.

5.4.5 Battery Storage

Over the span of this program, the position of the industrial quality lead calcium cell remained virtually unassailable by virtue of its suitability for unattended, extended service life photovoltaic applications. The two surviving contenders, the C&D 3KCP5A-5 and the Delco 2000, are both excellent and compatible quality devices. The Delco device provided a cost-effective solution that rated high on modular expandability. Its final rejection involved to a large degree the absence of substantive service life data (or projections) rather than the existence of major adverse-findings. The mean charge/discharge cycles to failure (MCCBF) were unable to be validated, thus forcing the use of a conservative estimated life figure. This value increased both the frequency of replacement over the twenty year life cycle and the life cycle costs. In distinction, the C&D cells were quite well documented from the life cycle survivability viewpoint.

A variety of protective battery enclosures was investigated for suitability for all environments except arctic applications. The dispersed, array shielded (with appropriate dust covers) installations offer environmental protection nearly equivalent to that of a prefabricated shed or a native materials enclosure. Even for arctic conditions, limited alternatives exist. For example, the electrolyte would not be permitted to drop below a specific gravity of 1.210; this would protect the cell to about -20°F , but would drastically limit available AH capacity. Alternatively, the enclosure could be heated to maintain the cells above 32°F . Either solution is undesirable

from an energy dissipation and cost viewpoint. The first alternative does not, of course, require a complex enclosure, only a significantly oversized battery. The second solution requires a somewhat costly, well-insulated heated structure with the attendant capital expenditures.

5.4.5 Electrical Protection

All proposed alternatives should employ the indicated interstructure bonding as well as a metallic counterpoise. The use of MOVs is recommended for protection against transients at the interfaces; power snubbers are considered essential for all DC switching devices. Ground fault crowbaring is included on all concepts. The selected concept does not disproportionately increase the costs or complexity of electrical protection; in fact, additional safeguards are provided by the intrinsically fail-safe characteristics of the normally open series contactors.

5.4.6 Load Management (LM)

These functions are common to all alternatives; the selected power control system configuration is fully compatible with LM circuit requirements. Preliminary designs and circuit configurations were yet under development at the time of the preliminary design review, only the operational features were available for presentation?

5.4.7 Operations and Maintenance

In distinction to shunt systems, the proposed series control provides automatic sectionalization when de-energized. Operating safety should be improved and fault diagnosis may be materially aided. Figure 5.4.7-1 depicts a generalized maintenance scenario.

5.5 Preliminary Designs Life Cycle Costs (LCC)

The procedures for generating the LCC for the stand-alone systems recommended for further analyses and preliminary designs were the same as those used for the conceptual designs.

Cost details were developed from various source data (e.g., vendors, contractors, etc.) based on the following:

- A. BOS Elements Under Consideration
 - 1. Structures and Foundations.
 - 2. Site Preparation, Installation.
 - 3. Array and Power Wiring.
 - 4. Power Controller.
 - 5. Batteries.
 - 6. Electrical Protection and Safety.
 - 7. Perimeter Security.
 - 8. O & M.
 - 9. Transportation.

B. General Assumptions

1. All design effort complete.
2. Preproduction Proof-of Design system has been verified as ready for production.
3. The system will be manufactured in a factory dedicated to production of photovoltaic power systems.
4. The annual production capacity of the factory is one megawatt (based on a 2 ft. by 4 ft. module rate at 64 watts at standard operating conditions).
5. System Life is twenty years.
6. There are not market distribution costs; systems are sold direct to user.
7. Burdened labor rates are:

<u>Factory</u>	\$18.50 per hour
<u>Field Labor</u>	
Supervisory	\$35.00 per hour
Skilled	\$28.00 per hour
Foreign/Unskilled	\$ 5.00 per hour

8. Material Mark-ups are:

Processed at factory (Mat'l burden + G&A & Fee)	30 percent
Shipped direct from vendor to site (G&A & Fee)	20 percent

C. LCC Factors

Rates of General Inflation:	12 percent
Escalation rate of capital costs:	12 percent
Escalation rate of O&M costs:	12 percent
Cost of capital:	15 percent
Base year for constant dollars	1981
First year of commercial production	1981

Cost details of each of the BOS follows. Costs were determined by obtaining quotations for each of the BOS from one or more vendors. Costs quoted were based upon quantities of materials needed for one magawatt of annual production. BOS element costs are given in terms of dollars per square meter of photovoltaic array for each of the preliminary designs. These summaries are shown in Tables 5.5-1, 5.5-2, and 5.5-3 for power levels of one kilowatt, four kilowatts and sixteen kilowatts, respectively.

1. Structures and Foundations -

Structures to support the PV panels are fabricated at the factory at standard factory labor costs. PV modules, assembled at the factory into panels, require one third of a man-hour per panel.

Foundation materials consisted of channels, tubs, frames and stanchions. As may be required for a given system, local labor was used to dig, install stanchions and refill.

Table 5.5-1.
Life Cycle Costs
Preliminary Designs
1-KW

BOS ELEMENT	\$/M ²		
	V	VI	VII
Array Structure & Foundations	30.20	28.81	28.81
Site Preparation/Installation	11.26	10.46	10.46
Array & Power Wiring	17.84	13.80	13.80
Power Controller*	82.03	72.07	65.64
Battery Subsystem	1092.68	1252.13	1352.13
Electrical Protection & Safety	14.31	11.45	11.45
Perimeter Security	137.49	137.49	137.49
Operations and Maintenance	688.99	535.19	535.19
Transporation (except Batteries)	42.25	33.80	33.80
TOTALS	2156.43	2195.20	2188.77

* Note: \$/M² refer to PV array area

* Does not include costs for load management; circuite undefined.

Table 5.5-2.
Life Cycle Costs
Preliminary Designs
4-KW

BOS ELEMENT	\$/M ²		
	V	VI	VII
Array Structure & Foundations	29.90	29.20	29.20
Site Preparation/Installation	10.83	10.27	10.27
Array & Power Wiring	21.45	23.74	23.74
Power Controller*	70.25	59.63	56.20
Battery Subsystem	1092.23	1352.07	1352.07
Electrical Protection & Safety	9.91	7.51	7.51
Perimeter Security	59.13	59.13	59.13
Operations and Maintenance	601.78	481.42	881.42
Transporation (except Batteries)	37.02	29.62	29.62
TOTALS	1932.50	2052.59	2049.16

* Does not include costs for load management; circuite undefined.

Table 5.5-3.
Life Cycle Costs
Preliminary Designs
16-KW

BOS ELEMENT	\$/M ²		
	V	VI	VII
Array Structure & Foundations	29.75	28.91	28.91
Site Preparation/Installation	10.64	10.48	10.48
Array & Power Wiring	23.12	23.32	22.32
Power Controller*	62.36	58.42	56.51
Battery Subsystem	1092.68	1352.09	1352.09
Electrical Protection & Safety	5.49	6.50	6.50
Perimeter Security	129.51	29.51	29.51
Operations and Maintenance	611.49	545.59	545.59
Transporation (except Batteries)	29.36	23.49	23.49
TOTALS	1894.40	2077.31	2075.32

* Does not include costs for load management; circuite undefined.

2. Site Preparation and Installation -
The site is generally a somewhat level, friendly site requiring no excavation. some clean-up and brush cleaning is required. The site slope is such that natural water drainage precludes the need for drainage trenches.

Trenching costs: \$0.024 per foot

3. Array and Power Wiring -
Quotations were received for wire, connectors, risers, PV Solarak connectors and miscellaneous parts required for the wiring subsystems. Typically, wire was priced at \$0.998 per ft.; riser, conduct and fittings at \$6.26; Solarak connectors at \$5.75.
4. Power Control and Regulation -
Prices for this system were obtained for electrical and mechanical parts, such as electrical components and boards, bracketry, switches, relays, controls, displays, J-boxes, etc. Costs were estimated at \$584.23. Factory labor to assemble and test was estimated at \$287. Wiring/hook-up of PV array and Power Control Module was estimated to take 2.5 hours, totaling \$70.00.
5. Batteries-
Several batteries qualify for use in each of the systems, depending on user desires for batter life and ease of replacement. LCC include the initial acquisition costs, recurring replacement costs, and both initial and recurring transportation costs. Costs details are:

<u>Cost Item</u>	<u>* Delco</u>	<u>** C & D</u>
Initial Cost	\$4,422	\$ 5,741
Recurring Cost	8,532	11,482
Initial Transport	248	520
Recurring Transort	1,488	1,040

* 3 year replacement

** 7 year replacement

6. Electrical Protection-
Prices for the grounding net and lighting protection included both parts procurement and labor for installation at the site. Trenching and backfill for the grounding net costs \$1.15 per foot. Wire, lugs, and miscellaneous parts were estimated at \$40.00.
7. Perimeter Security -
Fencing costs were determined from vendor quotes at \$8.50 per foot installed.

8. Operation and Maintenance -

The subsystems requiring field attention were:

Batteries	Water check, connections, replace.
Power Controller	Check fault status, check connections and replace faulted components, maintain log.
Electrical and Safety	Make electrical measurements, check and clean PV modules, maintain log.

Costs are primarily those for field labor; insignificant cost are allocated to small parts replacement.

9. Transportation -

Vendor furnished items include transportation costs from the vendor's facility to the PV factory. These costs were estimated and included as part of the BOS elements costs. This item is identified as an independent cost element.

10. Shipping -

A two kilowatt PV stand-alone system was used to establish costs for transporting the system hardware from Los Angeles, California to a typical transoceanic remote site. Due to high cost of shipping, and local availability of batteries, battery shipping costs were omitted.

Cost summaries by major subsystem element each of the preliminary design systems for one, four, and sixteen kW are included in Tables 5.5-1, 5.5-2, and 5.5-3.

6.0 FINAL MODULAR DESIGN

6.1 Introduction

The final baseline system design was executed under Task IV of the contract. Drawings and specifications sufficiently detailed to permit the construction, installation, operation, and maintenance of a baseline system were generated. This documentation included:

- (a) Electrical block, schematic and wiring diagrams of the baseline system.
- (b) Engineering drawings in agreement with specification DOD-D-1000B level 2.
- (c) Physical layout and overall size of the modular system.
- (d) Instrumentation recommended for incorporation in the operational system.
- (e) Parts lists with part sources, model number, and rated values.
- (f) Final sizing calculations, assumptions, and results.
- (g) Life Cycle cost estimates for the baseline modular system.

The electrical drawings define the various power and control circuits used in the final design. Table 6.2-1, "Power Rating Structure," depicts the family of system power ratings encompassed by these modular stand-alone designs. The types, values and sources for the components and integral subassemblies are also included. The electrical interfaces for the baseline modular system are shown, with the method of expansion to higher power ratings indicated. The wiring diagram and electrical layouts of the Power Controller and its integral subassemblies are also given, as is the electrical configuration of the modular battery packages. The mechanical drawings show the various structures, foundations and mechanical subassemblies. The general methods of installation and assembly are also presented. After the final design review, incorporation of indicated changes, and final approval, the Phase II option was exercised by NASA. This section covers major elements of the engineering drawing package. The baseline documentation is that considered most significant to presenting the detailed design approach.

6.2 Array Structures & Foundations

The structures and foundations provide a permanent and stable mounting platform for the power generating modules. With proper installation, the frameless panel supports in combination with either the ballasted planters of the concreted anchored post hole assemblies should readily survive at least twenty years' field service. Details of these structures and foundations are included in the drawing package, Section 7.0.

6.3 PV System Electrical Configuration

Figure 6.3-1 is the electrical schematic for the baseline 1 Power Unit system. The array field has an output of 1.28kWp. It consists of two parallel branches each rated 150 VDC at 4.3 Adc or 640 Wp. Each branch is a series string of 10 PV modules. Each module is 2 ft. x 4 ft., delivering a nominal 64 Wp. Table 6.3-2 illustrates the modular expansion of the array field to 16 kWp (16 PU) and its partitioning into a 1/2 PU (640 Wp) output and a 1/4 PU (320 Wp) output, respectively. The 1/4 PU rating requires the use of 1 ft. x

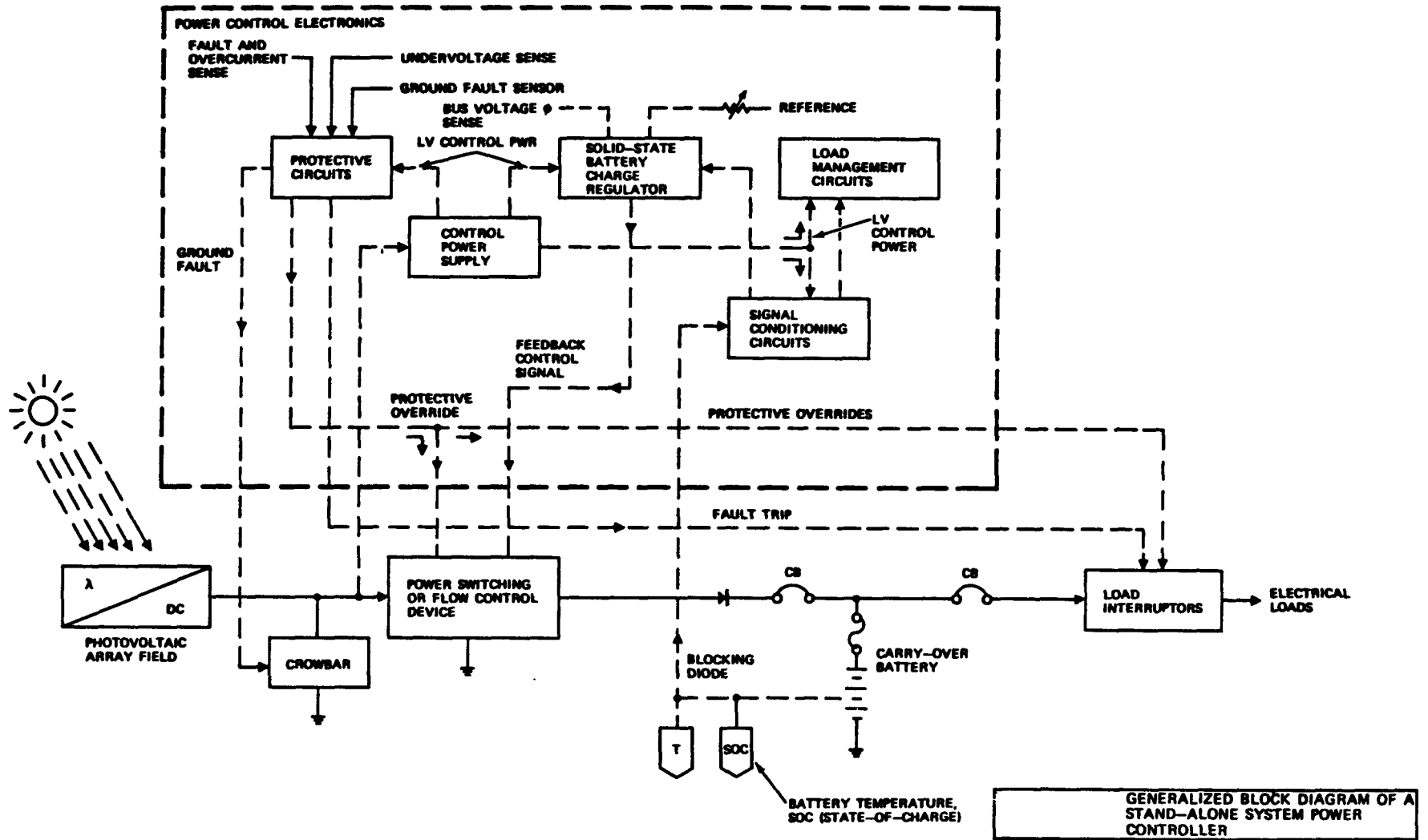

FIGURE 6.3-1

4 ft. (32 Wp) modules. The baseline battery string is a 60 cell/20 battery module complement of C&D 3KCP5A 3 cell packages, each cell rated 260 AH at the 8 hr. rate. The 1/4 and 1/2 PU ratings also use this basic complement; the battery strings are proportionally replicated for the higher ratings.

Table 6.2-1
Power Rating Structure

Power Unit (PU)	Peak Power from Array	Peak Array Current at 150 VDC	Basic Module	Array Power Branch Increments	Basic Battery String Complement	Basic Power Controller Capacity
1/4	320	2.1	1 x 4 (32W)	1/2	1 ea.	4 PU
1/2	640	4.3	2 x 4 (64W)	1	1 ea.	4 PU
1 **	1280	8.5	2 x 4 (64W)	2	2 ea.	4 PU
2	2560	17	2 x 4 (64W)	4	4 ea.	4 PU
4	3120	34	2 x 4 (64W)	8	8 ea.	4 PU
8	10,249	68	2 x 4 (64W)	16	16 ea.	8 PU
16	20,480	1363	2 x 4 (64W)	32	32 ea.	8 PU (2 ea.)

* At 1000 Watts/M² insolation; Air mass = 1.5; T_{ambient} = 25°C
 ** Baseline rating

Within the overall electrical system, the array field wiring and cabling provides the electrical power interface between the power generating array elements, the series module branches, and the power controller. Except for the fractional power unit ratings, the horizontal folded daisy chain string of 10 series, 15 volt/64 Wp modules will be employed.

For the extended higher power ratings, above 4 power units, transition from the intermodule wiring to the radial branch cabling is accomplished in a number of ways with the SOLARLOK connectors. The following wiring options are available:

- (1) Aerial/burial cable
- (2) Rigid metallic/non-metallic conduit, for special protection of power cables; IMC; or protected surface runs with aerial/burial cable.

Figure 6.3-2 is the specification control drawing for the Solarlok devices. Figure 6.3-3 is that of the "Supercon" connectors used in array battery and load terminations within the Power Controller. The branch currents are routed directly to the Power Controller. Radial collection methodology is employed throughout. A two string summing junction can be used directly at the termination of two subbranch loops in the event the smaller 1 ft. x 4 ft. modules are deployed in a 320Wp series string.

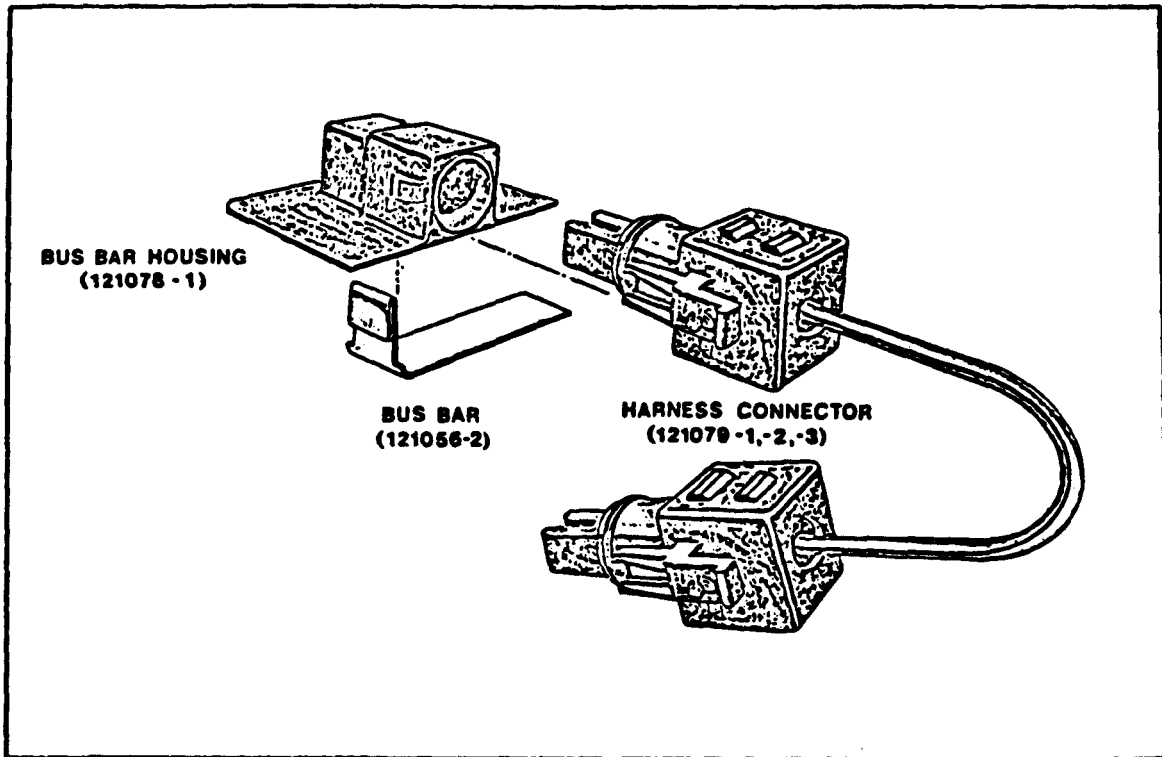

FIGURE-1

1.1 Description

AMP SOLARLOK* Connector was primarily designed and introduced to the Solar Energy Industry in 1979. The Connector system is packaged and initially available as a complete kit as shown in Figure-1.

1.2 Each kit consists of a one tab Bus Bar, Bus Bar Housing and Harness Connector with 18" wire length. The basic kit is available under AMP part number 121055-1.

1.3 Other kits will be available with variations in type and length of wire, 2 tab Bus Bars and assorted quantities of Bus Bar Housings and Harness Connectors to accommodate customer requirements.

1.4 Read the following instructions for specific information in regard to the AMP SOLARLOK* Connector installation for a typical module.

* TRADEMARK OF AMP INCORPORATED

Figure 6.3-2. Specification Control Drawing for Solarlok Connectors

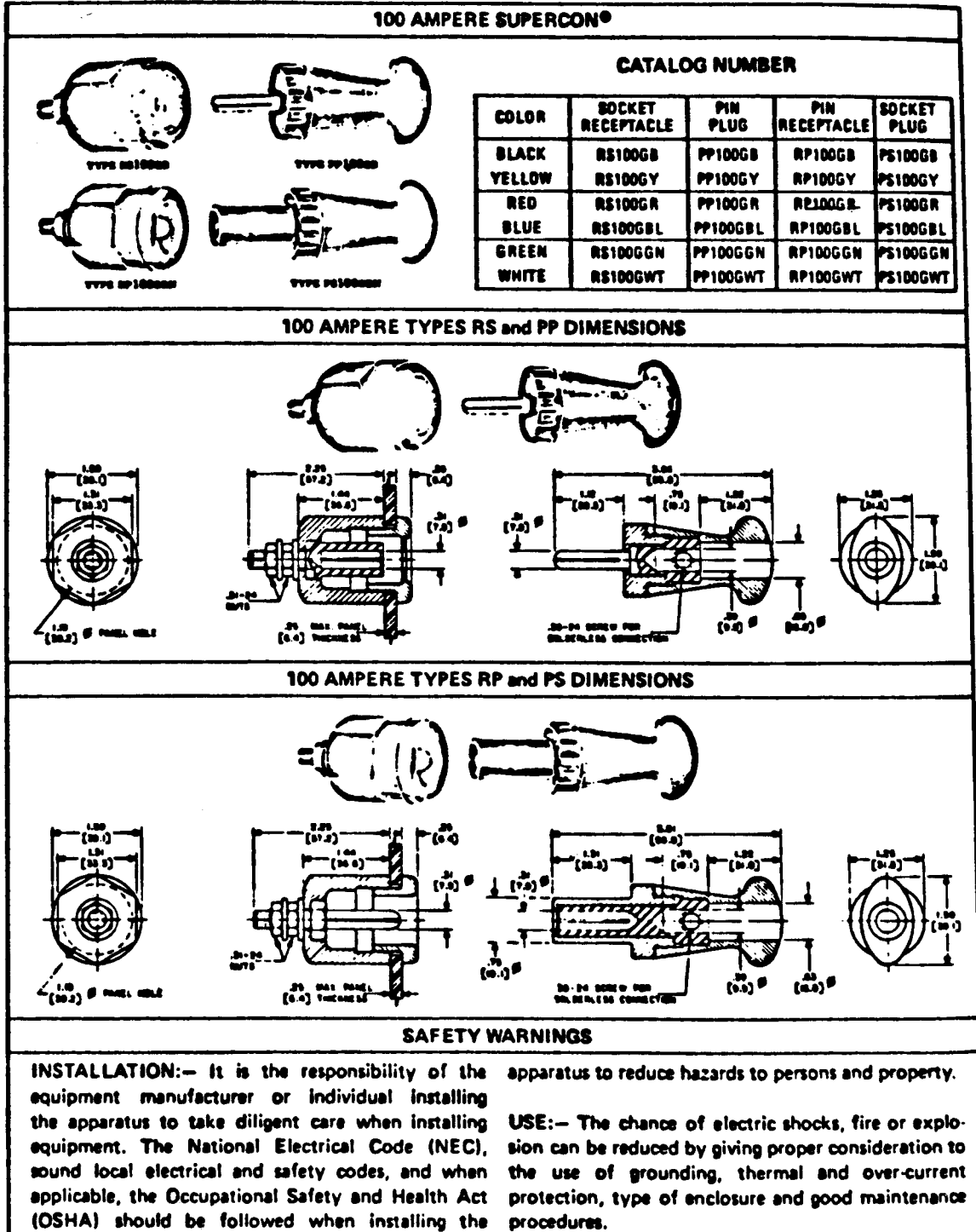

Figure 6.3-3. SCD for Supercon Connectors

6.4 Power Controller

The Power Controller (PC) is the collection, conditioning a distribution center for all system DC power. One basic Power Controller is furnished; this baseline configuration is used in all ratings through 8 PU. Power switching assemblies are progressively added with increasing power ratings. Figure 6.4-1 is the baseline 8 PU cabinet. Figure 6.4-2 is the cabinet and controller interface wiring diagram. The Power Controller also houses the Power Control Panel (PCP) and the Power Output Panel (POP). These panels and the associated hardware assemblies are also common for all systems. The Power Controller also accomodates all of the SOLARLOK male receptacles that interface with the PV array branch collection circuits as well as the "Supercon" load connectors outputting from the distribution circuit breakers. The PC cabinet also houses the high current summing bus or main lugs for maximum power rating. The battery strings are connected by "Supercon" connectors to these main lugs.

6.4.1 Power Control Panel (PCP)

The PCP houses all of the master electronic controls for the power systems. It includes the following:

- 1) The Two Channel Charger (Multi-Level) Regulator printed circuit board.
- 2) The Load Management printed board.
- 3) Summary system status displays and indicators and the zero centered battery current meter.
- 4) The ground fault relay.
- 5) The control system motherboard, electrically interfacing the power control devices, the electronic sensing and decisional circuits, the manual/ automatic control, and the displays and indicators.
- 6) Manual override controls and mode selectors.
- 7) All pilot relays required to energize the main contactors.
- 8) The dual redundant DC/DC converters, supplying 24 VDC control power.
- 9) System protective logic and control elements.
- 10) Interfaces with the Deltar S.O.C. sensors.

Figure 6.4-3 depicts the layout of the power control front panels and Figure 6.4-4 shows the interior physical arrangement of the several PCP subassemblies. Figure 6.4-5 is a schematic of the motherboard, and Figure 6.4-6 gives the physical layout of the major components. A low cost (\$0.25/watt) DC/DC converter is employed to efficiently obtain low voltage control power without dissipation in the dropping power resistor. The converter tare losses at full load (85 watts) are approximately 6 percent or 3.0 watts; the avoided power loss (as compared with the resistor method) is approximately 60 watts, all from the panels/battery at the expense of the load. Two converters are redundantly employed in the cold standby/manual switchover mode to assure continuous control power. A specification control drawing for the selected DC/DC converter is included as Figure 6.4-7.

* The 4 PU Power Controller is accomodated by using a cabinet one-half the height of the 8 PU cabinet.

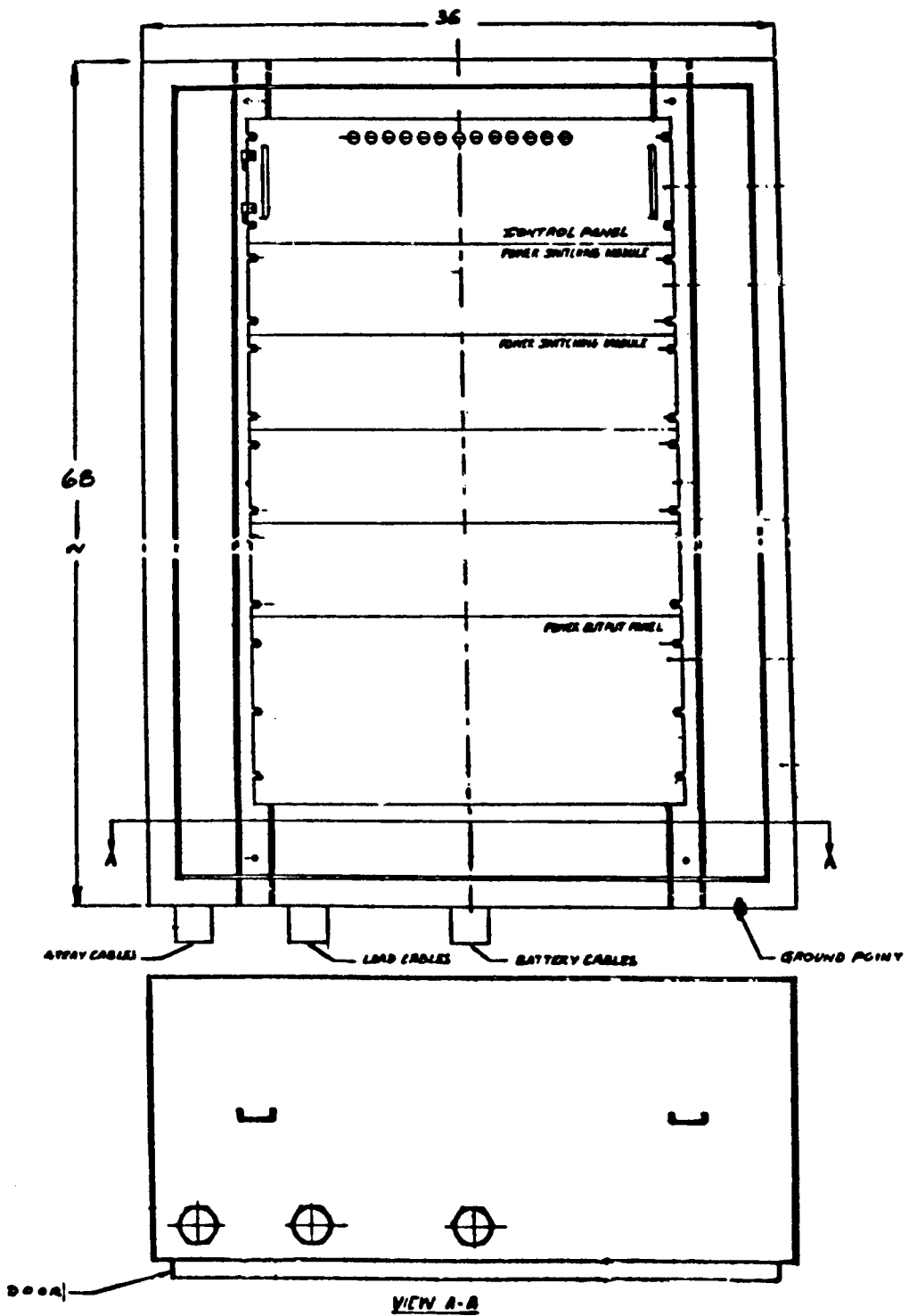

Figure 6.4-1. Power Controller Cabinet

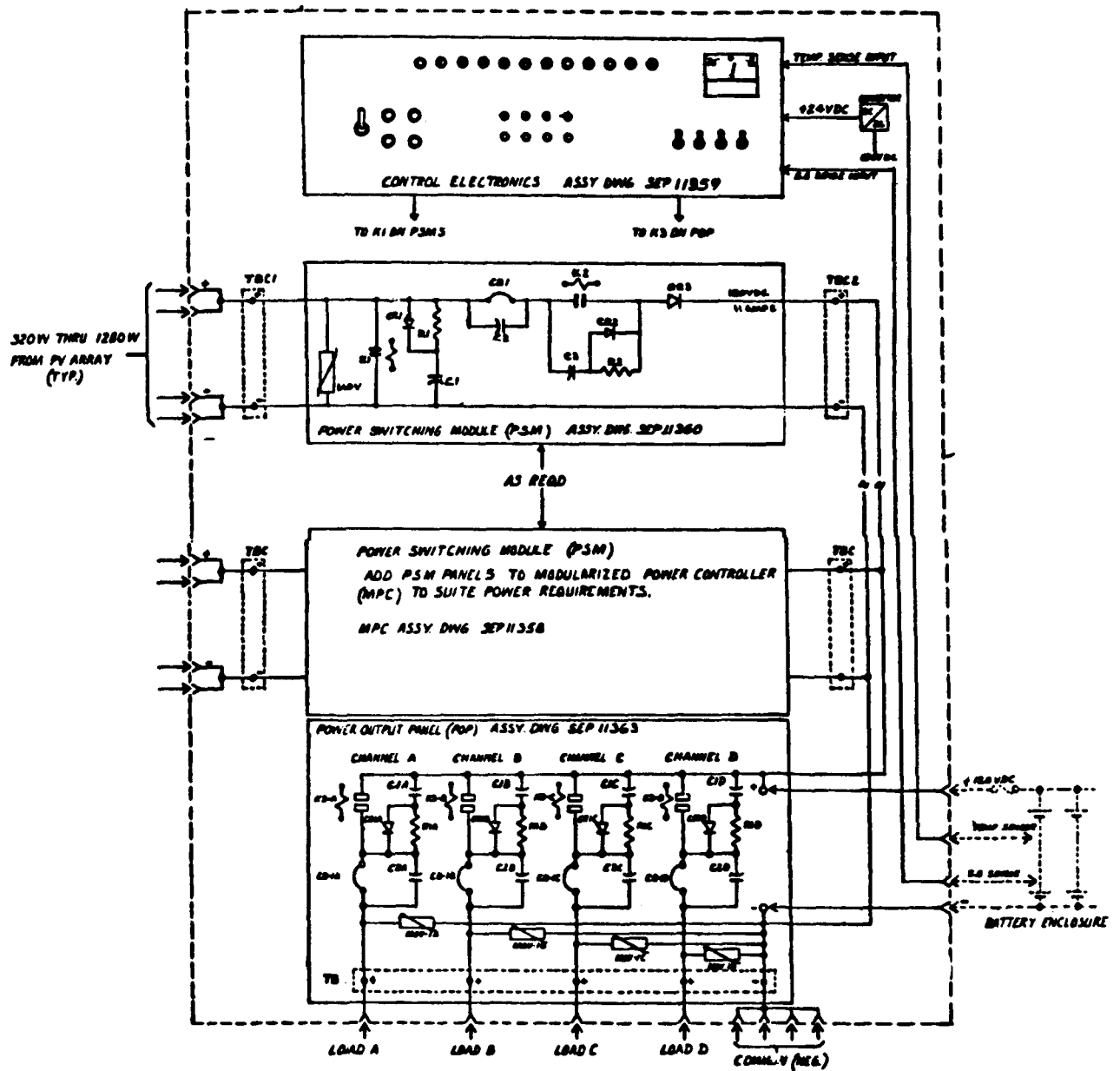
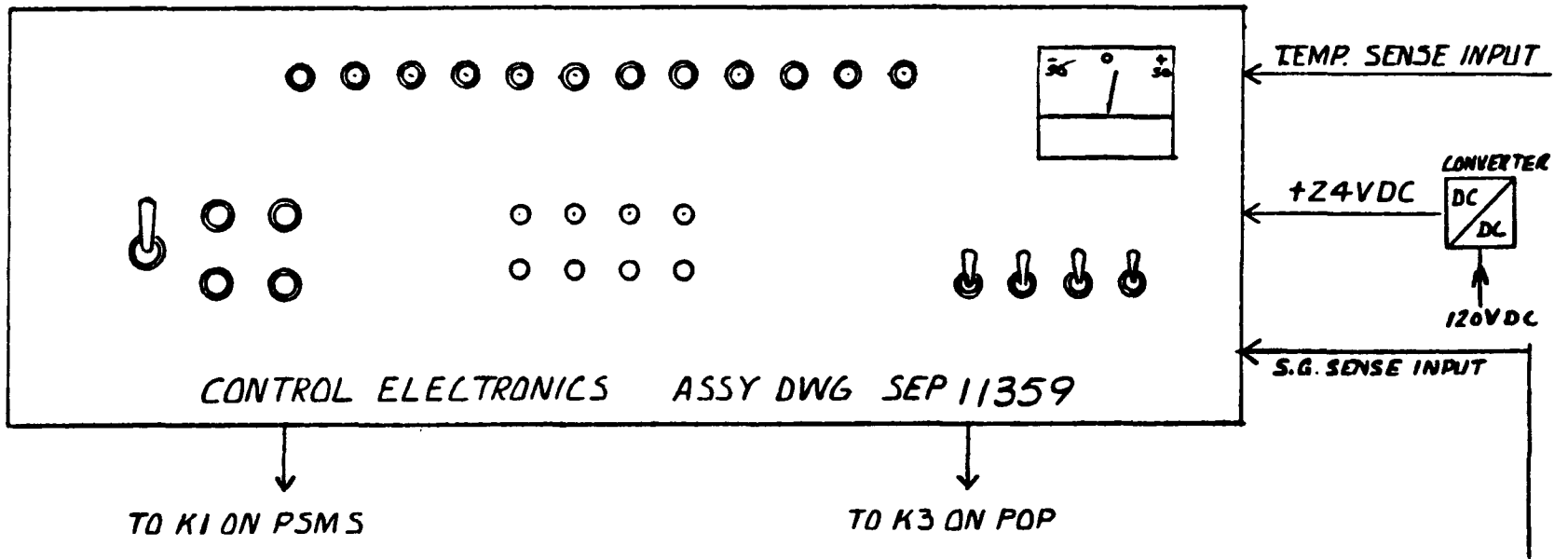

Figure 6.4-2. PC Cabinet Wiring Diagram

Figure 6.4-3. Power Control Panel (PCP): Front Panel Layout



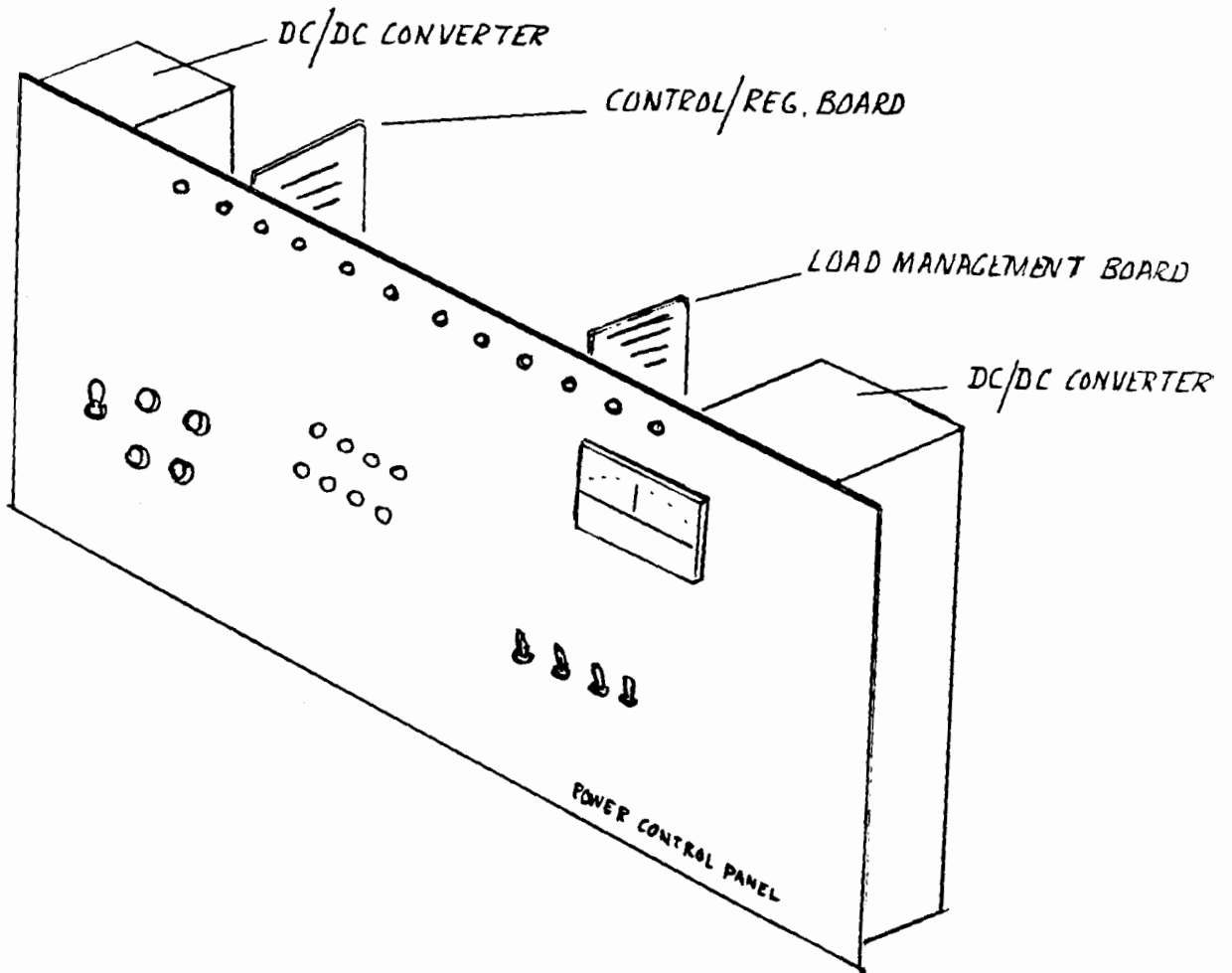

Figure 6.4-4. Interior Arrangements of PCP Subassemblies

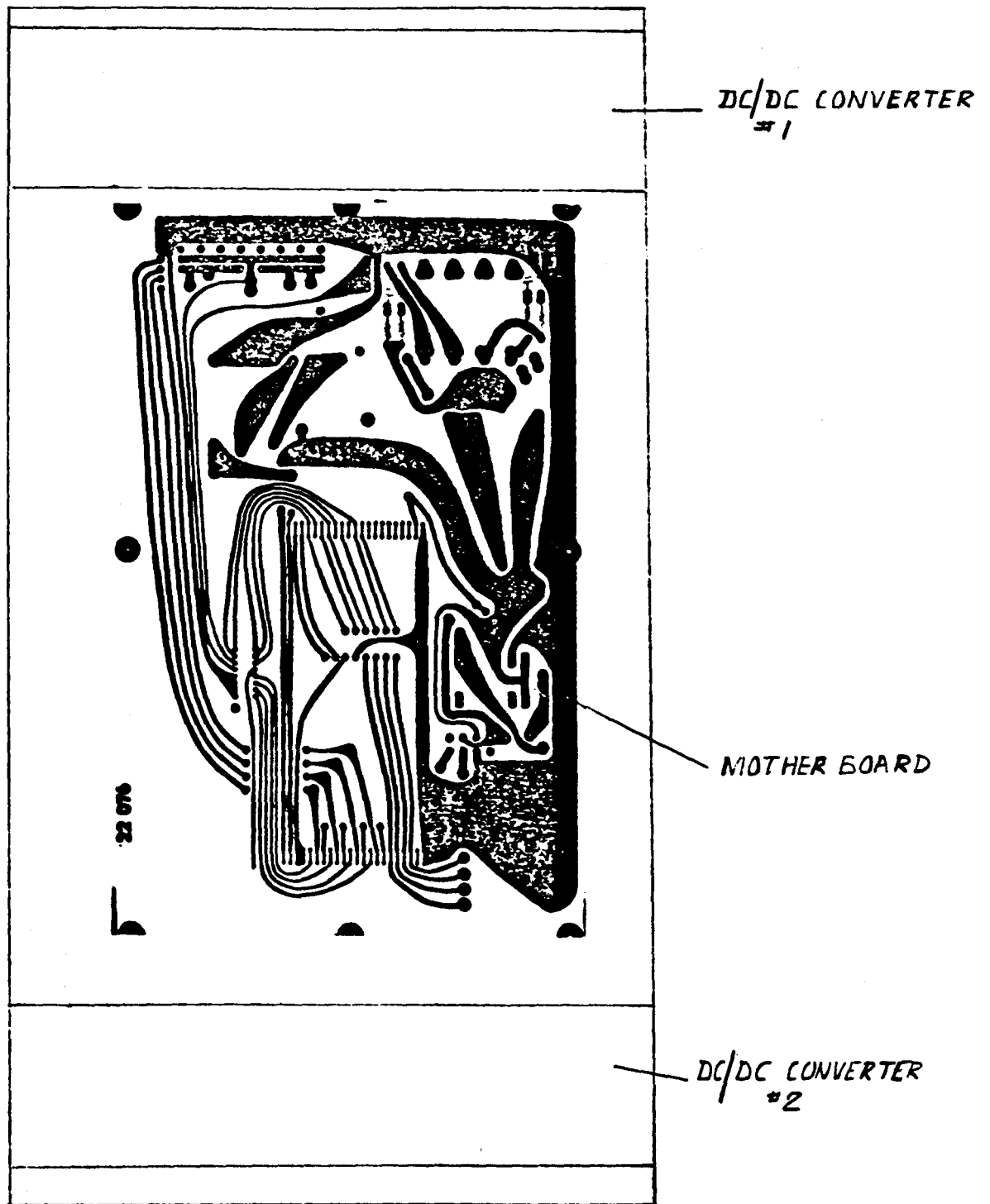

FIGURE 6.4-6. BACK VIEW LAYOUT OF PCP.

DC-DC UNREGULATED POWER CONVERTERS

• High Efficiency (90% Typ. & 71.) • Isolated Input/Output • 0.5% Maximum Ripple • Submodular Construction

11 TO 14 VDC INPUT					22 TO 30 VDC INPUT					44 TO 56 VDC INPUT					105 TO 140 VDC INPUT				
Output ● 12 VDC Input		Model No.	Case Size	Price (1-24)	Output ● 24 VDC Input		Model No.	Case Size	Price (1-24)	Output ● 48 VDC Input		Model No.	Case Size	Price (1-24)	Output ● 116 VDC Input		Model No.	Case Size	Price (1-24)
Voltage (VDC)	Current (Amps)				Voltage (VDC)	Current (Amps)				Voltage (VDC)	Current (Amps)				Voltage (VDC)	Current (Amps)			
12	4.0	DDU 1201	A	172.00	12	4.0	DDU 2401	A	172.00	12	4.0	DDU 4801	A	172.00	12	4.0	DDU 11001	A	172.00
	7.0	DDU 1202	B	195.00		7.0	DDU 2402	B	195.00		7.0	DDU 4802	B	195.00		7.0	DDU 11002	B	195.00
	12.0	DDU 1203	D	274.00		15.0	DDU 2403	D	274.00		15.0	DDU 4803	D	274.00		15.0	DDU 11003	D	274.00
24	2.0	DDU 1204	A	172.00	24	2.0	DDU 2404	A	172.00	24	2.0	DDU 4804	A	172.00	24	2.0	DDU 11004	A	172.00
	3.5	DDU 1205	B	195.00		3.5	DDU 2405	B	195.00		3.5	DDU 4805	B	195.00		3.5	DDU 11005	B	195.00
	6.0	DDU 1206	D	274.00		8.0	DDU 2406	D	274.00		8.0	DDU 4806	D	274.00		8.0	DDU 11006	D	274.00
48	1.0	DDU 1207	A	172.00	48	1.0	DDU 2407	A	172.00	48	1.0	DDU 4807	A	172.00	48	1.0	DDU 11007	A	172.00
	1.8	DDU 1208	B	195.00		1.8	DDU 2408	B	195.00		1.8	DDU 4808	B	195.00		1.8	DDU 11008	B	195.00
	3.0	DDU 1209	D	274.00		4.0	DDU 2409	D	274.00		4.0	DDU 4809	D	274.00		4.0	DDU 11009	D	274.00
110	0.5	DDU 1210	A	172.00	110	0.5	DDU 2410	A	172.00	110	0.5	DDU 4810	A	172.00	110	0.5	DDU 11010	A	172.00
	0.8	DDU 1211	B	195.00		0.8	DDU 2411	B	195.00		0.8	DDU 4811	B	195.00		0.8	DDU 11011	B	195.00
	1.5	DDU 1212	D	274.00		2.0	DDU 2412	D	274.00		2.0	DDU 4812	D	274.00		2.0	DDU 11012	D	274.00

AC-DC REGULATED POWER CONVERTERS

• Pulse Width Modulated Inverters or Switching Output Regulators for Outputs > 10A or 100W • 220 VAC Input Option* • Operate on AC or DC Inputs
 • 105-125 VAC, 47-420 Hz Input • 0.2% Line Regulation (LL-HL) • 0.2% or 20 mV Load Regulation (NL-FL) • 0.3% Maximum Ripple
 • Overload / Short Circuit Protected • Lightweight / Small Size • 5% Output Voltage Adjust Range • Overvoltage Protection Option*
 • Submodular Construction

SINGLE OUTPUT MODELS

Output Voltage (VDC)	Current (Amps)	Model No.	Case Size	Price (1-24)
5	5.0	ADR 1100	B	233.00
	10.0	ADR 1101	C	271.00
	25.0	ADS 1112	E	536.00
12	2.0	ADR 1102	B	233.00
	5.0	ADR 1103	C	271.00
	13.0	ADS 1113	E	536.00
15	2.0	ADR 1104	B	233.00
	4.0	ADR 1105	C	271.00
	12.0	ADS 1114	E	536.00
28	1.0	ADR 1106	B	233.00
	2.0	ADR 1107	C	271.00
	8.0	ADS 1115	E	536.00
48	0.5	ADR 1108	B	245.00
	1.0	ADR 1109	C	250.00
48	4.0	ADR 1116	E	536.00
	0.3	ADR 1110	B	245.00
200	0.1	ADR 1111	B	245.00
	0.1	ADR 1117	B	251.00

MULTIPLE OUTPUT MODELS

Output Voltage (VDC)	Current (Amps)	Model No.	Case Size	Price (1-24)
+15	2.0	ADR 1122	B	304.00
-15	2.0			
+12	4.0	ADR 1138	E	438.00
-12	4.0			
+15	4.0	ADR 1127	E	438.00
-15	4.0			
+28	1.0	ADR 1128	B	304.00
-28	1.0			
+28	2.0	ADR 1129	E	438.00
-28	2.0			
+5	2.0	ADR 1139	B	286.00
+12	0.5			
-12	0.5	ADR 1123	B	286.00
+5	2.0			
+5	0.5	ADR 1123	B	286.00
+15	0.5			
-15	0.5	ADR 1140	C	359.00
+5	5.0			
+12	1.0	ADR 1140	C	359.00
-12	1.0			
+5	5.0	ADR 1124	C	359.00
+15	1.0			
-15	1.0	ADR 1141	C	325.00
+5	8.0			
+5	0.5	ADR 1141	C	325.00
+12	0.5			
-12	0.5	ADR 1125	C	325.00
+5	8.0			
+15	0.5	ADR 1125	C	325.00
-15	0.5			
+5	0.1	ADR 1131	E	582.00
+12	3.0			
+15	1.0	ADR 1131	E	582.00
-15	1.0			
+12	6.0	ADR 1131	E	582.00
+15	2.0			
-15	2.0	ADS 1132	G	734.00
+5	5.0			
+15	0.5	ADR 1126	C	382.00
-15	0.5			
+250	0.1	ADR 1126	C	382.00

* Overvoltage Option: Add "V" followed by voltage to be protected. Example: ADR1128 V5 has 5 VDC output protected.
 Price: \$25 for outputs up to 10A, \$38 over 10A.
 * 220 VAC Input: Contact factory.

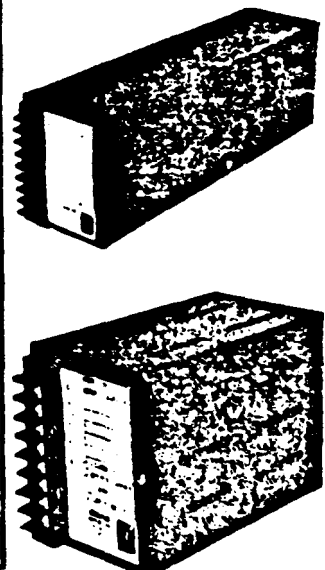

TEMPERATURE RATINGS FOR ALL MODELS

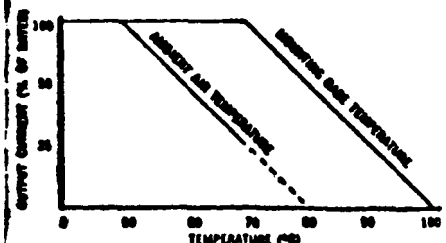

MECHANICAL SPECIFICATIONS FOR ALL MODELS

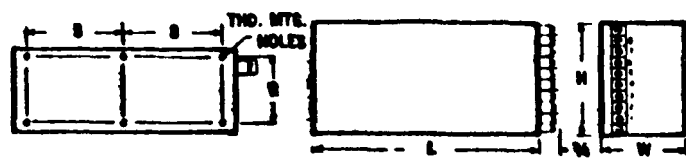

Case	L	W	H	S	H	Number of Mounting Nuts / Thread Size	Weight (Typ.)
A	5 1/4 (14.61)	3 (7.62)	4 (10.16)	2.4 (6.10)	5 (12.70)	4 / #6-32 TMD.	1 1/4 (1.57)
B	6 (20.32)	3 (7.62)	4 (10.16)	2.4 (6.10)	3.5 (8.89)	6 / #6-32 TMD.	1 3/4 (1.70)
C	12 (30.48)	3 (7.62)	4 (10.16)	2.4 (6.10)	5.5 (13.97)	6 / #6-32 TMD.	2 1/2 (1.13)
D	10 (25.40)	4 (10.16)	4 1/4 (11.75)	3 (7.62)	4.5 (11.43)	6 / #10-32 TMD.	3 1/2 (1.50)
E	15 (38.10)	4 (10.16)	4 1/4 (11.75)	3 (7.62)	4.5 (11.43)	8 / #10-32 TMD.	4 1/4 (1.93)
G	15 (38.10)	6 (15.24)	4 1/4 (11.75)	5 (12.7)	4.5 (11.43)	8 / #10-32 TMD.	6 (2.72)

NOTE: Sizes, Inches (CM); Weight, Pounds (KG)

Figure 6.4-7. SCD for DC/DC Converter

6.4.2 Universal Control Board Printed Circuit

The multilevel charge control circuits and the load management decisional circuits utilize a common printed circuit board. The change of a limited number of divider resistor values and sense inputs plus the deletion of the temperature compensation function and the addition of the DELTAR sense inputs convert a charge regulator board to LM control board (and vice-versa). In the load management function the inputs to each of four dual state comparators are dedicated respectively to each of four Deltar sensor outputs corresponding to 20 percent, 40 percent, 60 percent and 80 percent state of charge. In the multilevel regulator configuration, two comparators are dedicated to the dual channel regulation and the third to undervoltage trip. The fourth channel is presently uncommitted and available as a spare. Figure 6.4-8 is the schematic of this common plug-in element; both configurations are shown. In the standard circuit the comparator IC outputs to a bipolar drive transistor which in turn operates a one-half crystal cave hermetic relay. The charge regulation channel output relays can energize up to eight series switching Durakool contactors. In the LM configuration, each of the four comparator output relays energizes the corresponding contactor in that particular prioritized load bus. Each comparator has in turn been actuated by an output level change in the DELTAR Specific Gravity sensor assigned to that particular channel. Figure 6.4-9 is a specification control drawing of the Deltar sensor assembly. Figure 6.4-10 depicts the sensor assembly "J" box installed in close proximity to the designated pilot cells.

6.4.3 Power Switching Assembly

The Power Switching Assembly (PSA) consolidates all input power switching elements for each 1 PU (1.28 kWp) increment on a single panel strip. The baseline 1 PU system uses two PSAs, which permits multilevel charge regulation at a cost delta of approximately \$0.2/watt. Figure 6.4-11 shows the layout of a single PSA panel; Figure 6.4-12 depicts the interior layout and the intraconnective wiring. The Power Switching Assembly (PSA) accepts the output of contribution to the summing (battery) bus. It includes the following control/protective switchgear:

- 1) An input circuit breaker for manually connecting/disconnecting the particular array branch involved.
- 2) A crowbar contactor, part of system protection.
- 3) A series power relay of the hermetic mercury displacement type, protected by a snubber, and performing the dual function of the power pass element in the feedback control loop and "overvoltage shutdown."

REV	AUTHORITY	DATE	APPROVED

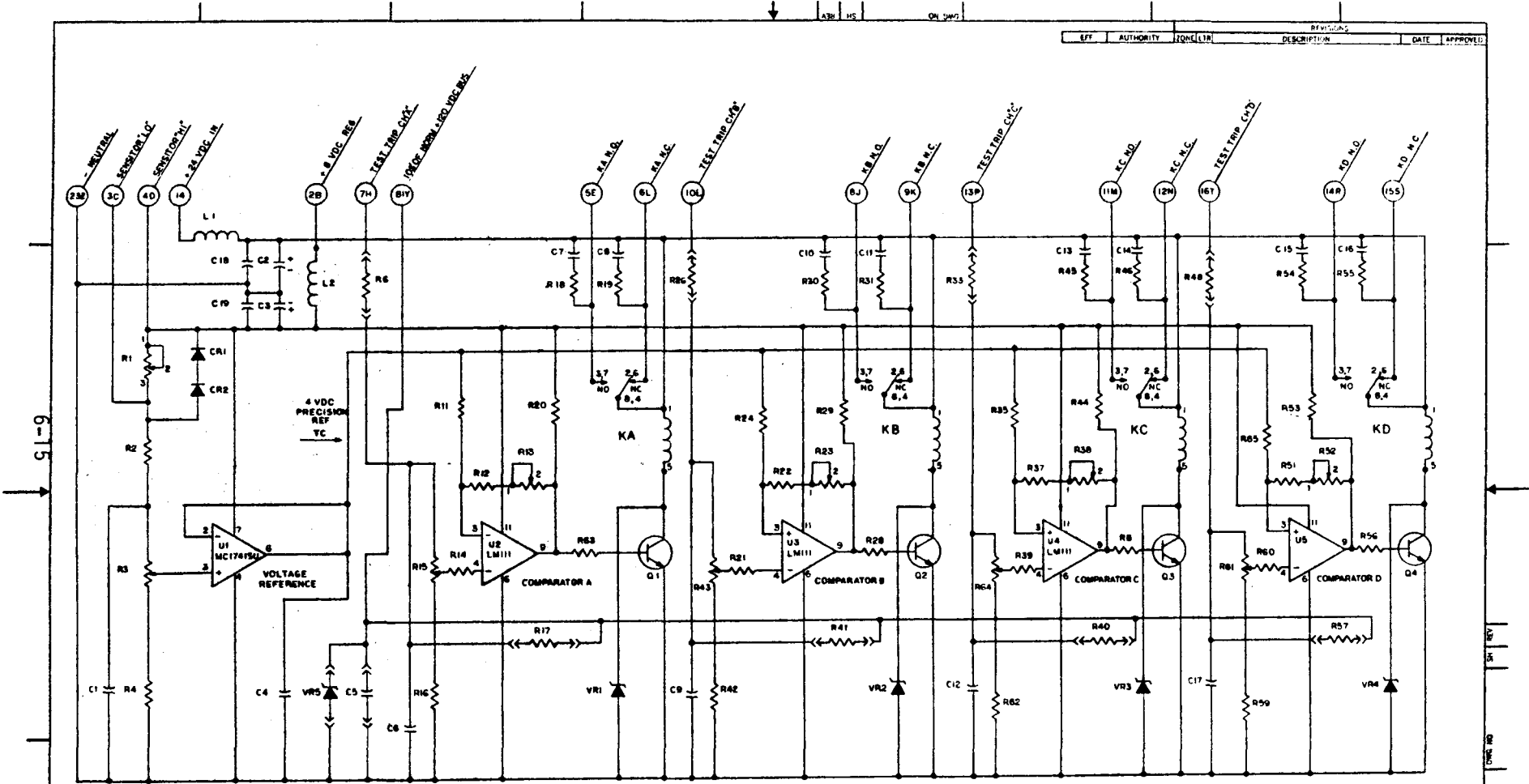

CHARGE/REGULATOR CONFIGURATION - 02
 FIGURE 6.4-8. SCHEMATIC OF UNIVERSAL CONTROL PRINTED CIRCUIT BOARD

MUHRES AIRCRAFT COMPANY EL SEGUNDO CALIFORNIA	CONTROL DATA LEWIS POWER CONTROLLER
--	-------------------------------------

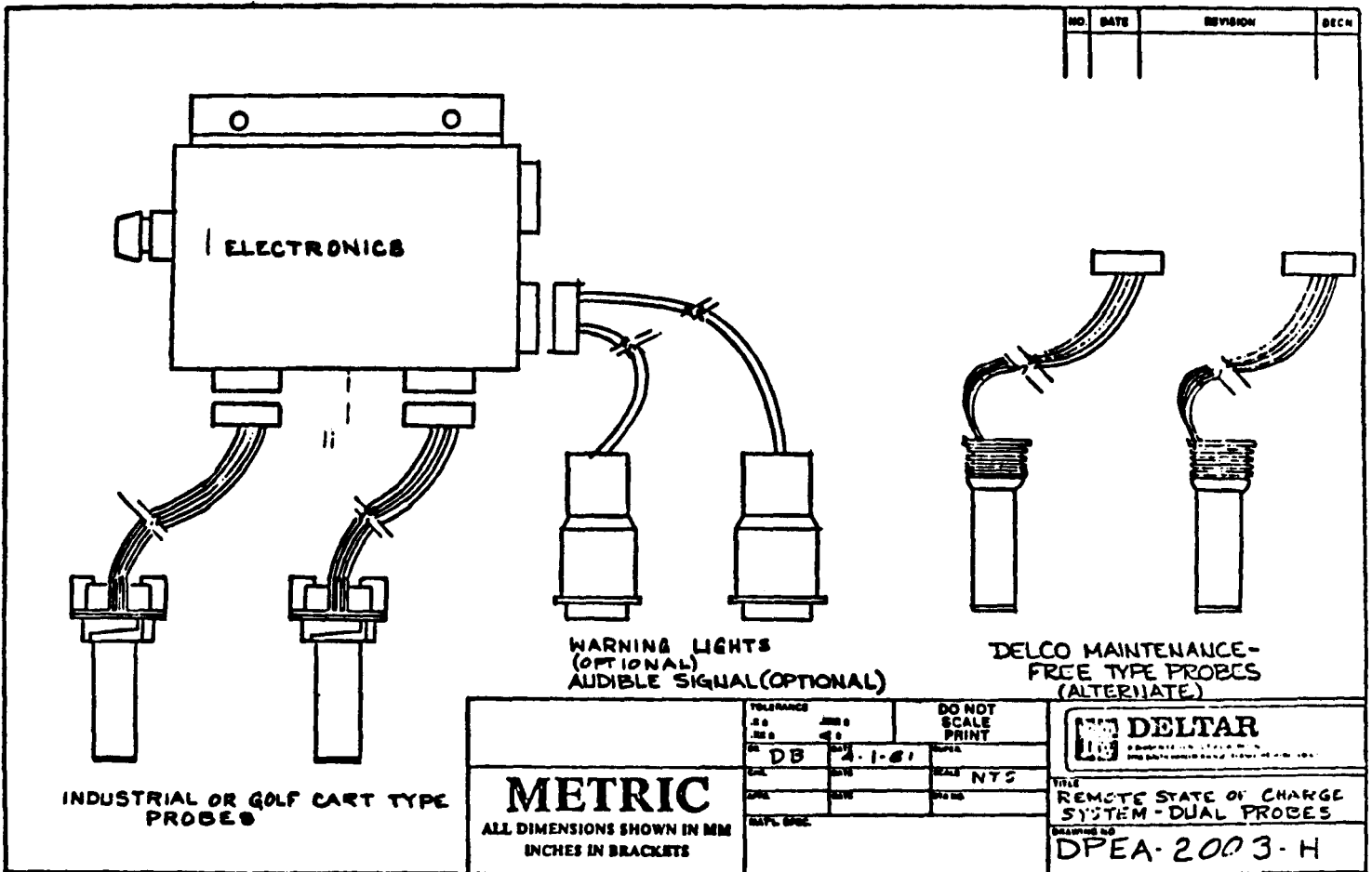

Figure 6.4-9. SCD for DELTAR Sensor

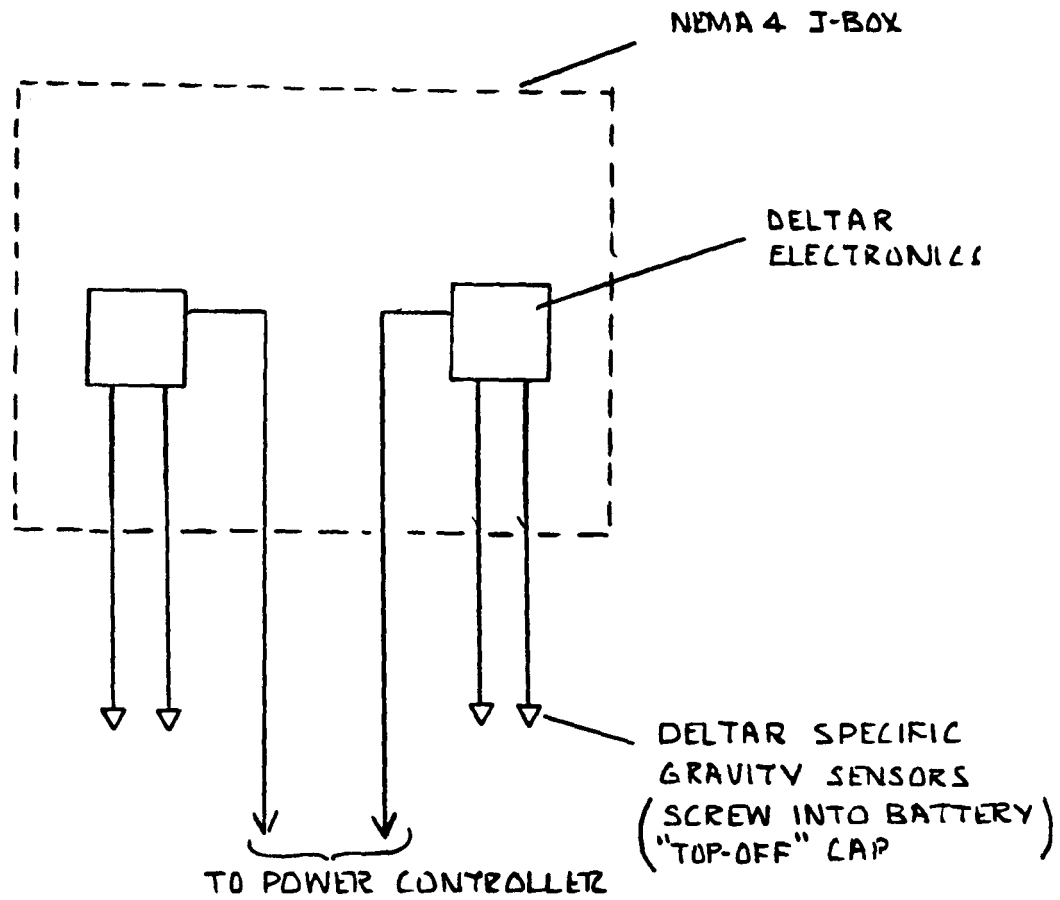
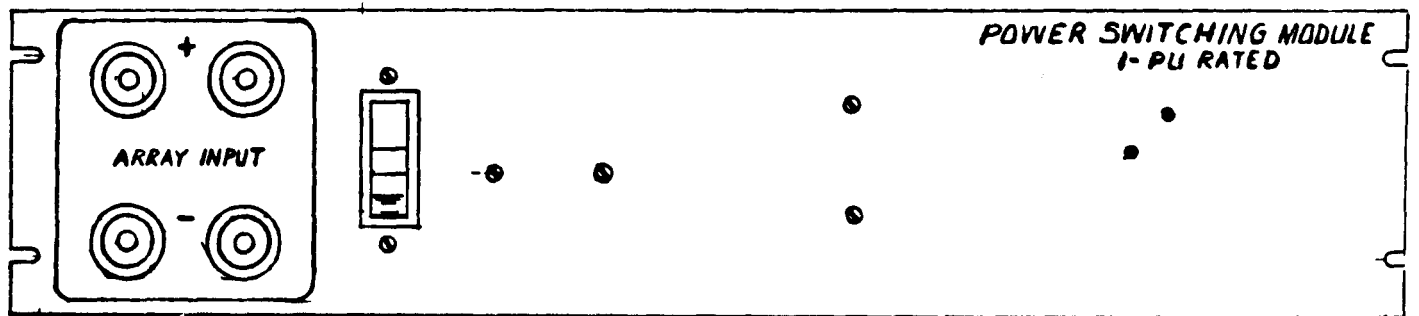
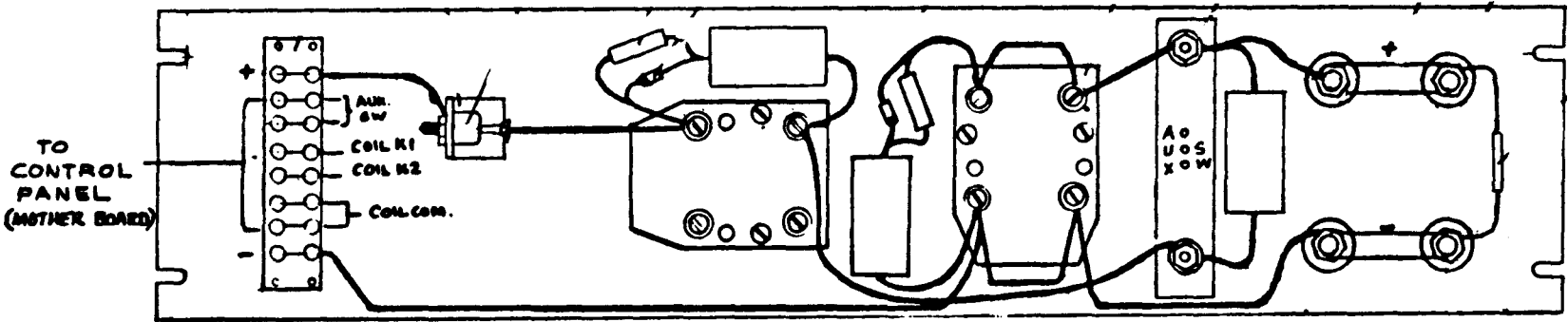

Figure 6.4-10. DELTA "J" Box Layout of Wiring Diagram



PANEL FRONT VIEW

Figure 6.4-11. Power Switching Assembly Panel Layout



PANEL REAR VIEW

Figure 6.4-12. PSA Interim layout and wiring

The blocking diode, CR-1, precludes potentially damaging back current flow from the main power bus in the event of a faulted array element. The power snubber circuits used with the hermetic contactors result in virtually arcless power interruption, thus ensuring MCBF (mean-cycles-before-failure) exceeds several million cycles. The less frequently deployed circuit breakers likewise employ power snubbers, precluding contact erosion and absorption switching transients, keeping the array/panel wiring from being possible EMI radiators. Metallic Oxide Varistors are included on the PSA Input to hold potentially damaging voltage surges to safe dielectric levels. Up to eight power switching assemblies may be installed in the power controller cabinet, accomodating ratings up to 8 PU or 10.24 kWp. The summing (battery) bus output connection is readily made by installation of standard lugs and jumpers; the array branch inputs are directly routed into the PSA Solarloks and are independent of other array circuits.

* By using 2 each 8 PU controllers, 16 PU is achieved.

6.4.4 Power Output Panel (POP)

The Power Output Panel (POP) is depicted in two drawings, the front panel layout drawing, Figure 6.4-13, and the interim arrangement and wiring interconnection drawings, Figure 6.4-14. The POP incorporates the output contractors that control the power flow to the four prioritized load outputs. It also includes the four back-up low voltage circuit breakers that provide manual load break and automatic fault trip. Each output panel will accomodate up to four circuit breakers and contractors with an aggregate 100 ADC continous rating at 250 VDC.

The POP circuit breakers, as well as the array side disconnects are Heinamen CDI series with auxiliary contacts. Their continuous carry and fault trip ratings are coordinated with battery fusing and vary with system rating. For the baseline one power unit (1 PU), the Heinamen breakers Model CDI-132-DU30-125-1 have been selected for 15 amperes continuous carry and an inverse time trip characteristics $t_1 = 1 \text{ sec}/700 \text{ percent continuous}$. The four hermetic mercury displacement contactors, Durakool Model BF7046, each in series with the circuit breaker, are dedicated to that particular prioritized distribution feeder. The panel also includes the master control relay that interdicts the holding current on each of the four prioritized bus contactor coils in the event of sensing a catastrophic battery undervoltage, nominally less than 1.75 VDC at 25 C. The panel also includes the main lugs for the load output and battery input. The load buses are outputted with Supercon connectors; the (+) and (-) battery inputs also interface with the same system, but with device ratings incompatible, and non-interchangeable, with the load connectors.

6.5 The Lead Calcium Battery

The Lead-Calcium Battery, the C&D 3KCP5A-5, selected for this application represents the best present off-the-shelf product, consistent with reliability performance, life cycle cost, and field handling requirements. Figure 6.5-1, the Specification Control Drawing, fully characterizes this battery. Figure 6.5-2 summarizes pertinent installation and maintenance data. The baseline one power unit (1 PU) battery consists of twenty of these 3 cell batteries in series, giving a nominal 120 VDC bus voltage.

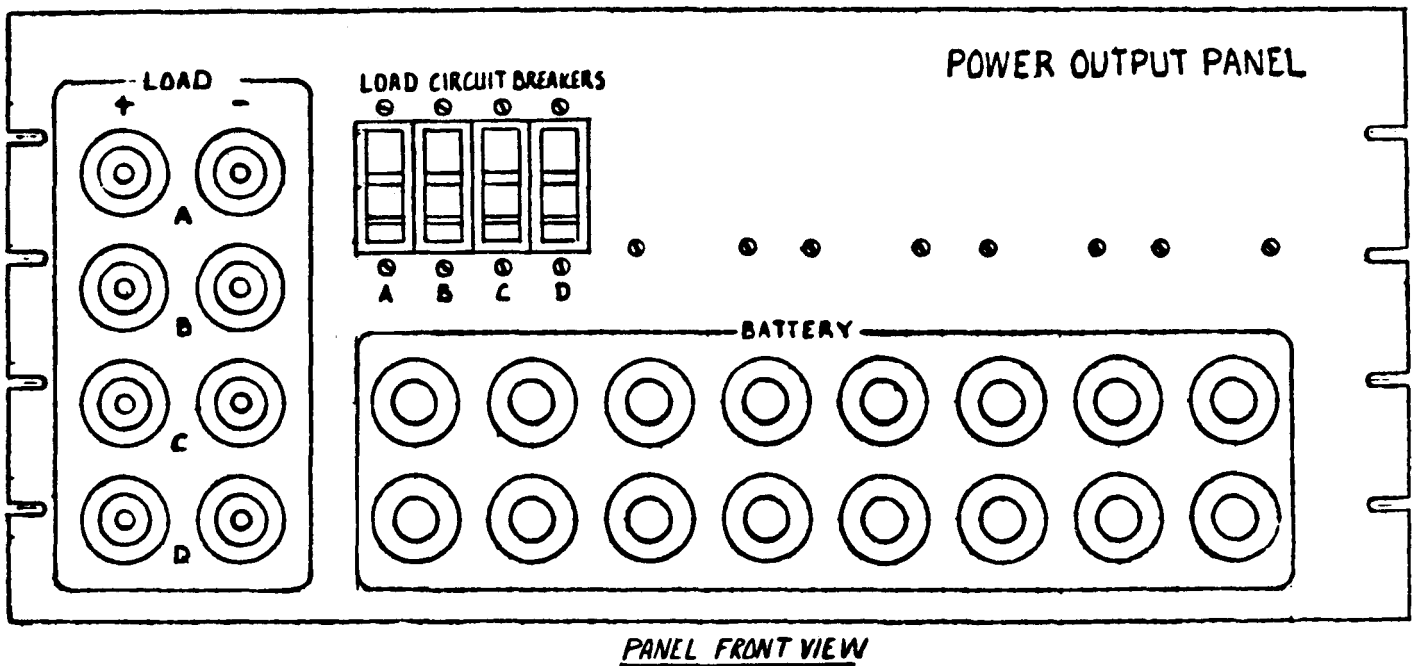

Figure 6.4-13. Power Output Panel (POP): Front Panel Layout

NORMAL AND COLD CLIMATE APPLICATION DATA

For Average Annual Temperatures less than 90°F (32°C)

Type	AH Capacity					Dimensions						Weight		Max. AH to 0°F FP*
	8 Hr.	100 Hr.	500 Hr.			Length		Width		Height		lbs.	kg.	
	77°F (25°C)	77°F (25°C)	77°F (25°C)	32°F (0°C)	0°F (-18°C)	in.	mm	in.	mm	in.	mm			
PSA-3	31	42	50	45	36	3.59	91	7.38	187	10.31	262	18.4	8.3	50
3 DCPSA-3	31	42	50	45	36	5.28	134	7.38	187	10.31	262	27.7	12.6	50
2 DCPSA-5	62	73	75	68	55	3.59	91	7.38	187	10.31	262	22.6	10.3	67
3 DCPSA-5	62	73	75	68	55	5.28	134	7.38	187	10.31	262	33.6	15.2	67
2 DCPSA-7	94	128	150	134	109	6.38	162	7.38	187	10.31	262	36.9	16.7	139
3 DCPSA-7	94	128	150	134	109	9.47	241	7.38	187	10.31	262	54.3	24.6	139
2 DCPSA-9	125	140	145	129	105	6.38	162	7.38	187	10.31	262	40.8	18.5	128
3 DCPSA-9	125	140	145	129	105	9.47	241	7.38	187	10.31	262	61.2	27.8	128
DCPSA-11	156	212	250	224	182	6.38	162	7.38	187	10.75	273	37	16.8	250
DCPSA-13	188	255	300	268	218	6.38	162	7.38	187	10.75	273	39	17.7	286
DCPSA-15	219	300	310	276	225	6.38	162	7.38	187	10.75	273	41	18.6	274
DCPSA-17	250	286	295	264	215	6.38	162	7.38	187	10.75	273	42	19.1	261
2 KCPSA-5	225	289	340	306	249	5.59	142	10.44	265	18.25	464	88	39.9	304
3 KCPSA-5	225	289	340	306	249	8.53	217	10.44	265	18.25	464	131	59.4	304
KCPSA-7	337	358	400	336	293	3.62	92	10.44	265	18.25	464	58	26.3	357
KCPSA-9	450	509	525	471	384	4.62	117	10.44	265	18.25	464	79	35.8	467
KCPSA-11	562	625	645	579	471	5.59	142	10.44	265	18.25	464	96	43.5	574
KCPSA-13	675	747	770	690	561	6.59	167	10.44	265	18.25	464	113	51.3	684
KCPSA-15	787	1023	1055	951	774	8.53	217	10.44	265	18.25	464	139	63.0	943
KCPSA-17	900	992	1023	891	725	8.53	217	10.44	265	18.25	464	146	66.2	909
4 LCPSA-5	420	518	535	479	390	10.14	258	14.12	359	22.62	575	276	125.2	474
4 LCPSA-7	630	795	820	734	597	15.00	381	14.12	359	22.62	575	391	177.4	727
LCPSA-11	1050	1402	1650	1476	1202	7.62	194	14.12	359	22.62	575	188	85.3	1577
LCPSA-13	1260	1649	1700	1521	1238	7.62	194	14.12	359	22.62	575	205	93.0	1508
LCPSA-15	1470	1571	1620	1451	1182	7.62	194	14.12	359	22.62	575	222	100.7	1439
LCPSA-17	1680	1867	1925	1723	1403	8.62	219	14.12	359	22.62	575	254	115.2	1707
LCPSA-19	1890	2308	2380	2132	1735	10.62	270	14.12	359	22.62	575	294	133.4	2113
LCPSA-21	2100	2231	2300	2061	1678	10.62	270	14.12	359	22.62	575	310	140.6	2042
LCPSA-23	2310	2880	2970	2658	2163	13.19	335	14.12	359	22.62	575	353	160.1	2364
LCPSA-25	2520	2803	2890	2589	2107	13.19	335	14.12	359	22.62	575	370	167.8	2565

Recommended Charge Voltage — 2.45 to 2.49 volts per cell @ 77°F (25°C)
 Specific Gravity at 77°F (25°C) — Full Charge — 1.300
 Specific Gravity at 77°F (25°C) — 100% Discharge — 1.130 @ 500 Hour Rate
 Specific Gravity at 32°F (0°C) — 100% Discharge — 1.180 @ 500 Hour Rate
 *Electrolyte will not freeze if these values are not exceeded.

Figure 6.5-1. SCD for 3 KCPSA-5

CONDENSED INSTRUCTIONS FOR STANDBY BATTERY SERVICE, FULL FLOAT OPERATION

CAUTION:

WET BATTERIES must be placed on charge within 3 months if lead-antimony or 6 months if lead-calcium from time of shipment from factory.

DRY-CHARGED BATTERIES must be properly activated and charged within 12 months. See RS-564 or pages 13 & 14 in Section 12-900.

WARNING:

Electrolyte is an acid and can cause severe burns. Always wear protective clothing such as a rubber apron, safety goggles and rubber gloves when working around batteries.

1. **RECEIVING** - If packing material shows evidence of physical damage or spillage of electrolyte make notation on bill of lading before signing. Check electrolyte level in each cell. It should be between low and high level lines. If more than 1/4" of plate surface has been exposed to air, the cell has suffered permanent damage and should be replaced.

2. **INSTALLATION** - Locate battery in a cool clean dry place so no cells are affected by radiators, heaters, or pipes. Arrange cells on rack so they can be connected positive to negative throughout. Connections between cells must be clean, dry, free of acid and coated with

NO-OX-ID grease before bolting together. SEE SECTION 3.3 to 3.11 of "Installation and Operating Instructions", Section 12-900.

3. **CONNECTING BATTERY TO CHARGER** - Only direct current (dc) is used for charging. Connect battery positive terminal to charger positive terminal and battery negative terminal to charger negative terminal.

4. **WATERING** - Add approved or distilled water after charging and as required to keep electrolyte level between high and low level lines on container.

5. **CLEANING** - Keep outside of cells clean and dry by wiping with a water damp cloth as required and dry. Neutralize any acid on covers or connectors with a cloth moistened with a solution of baking soda and water, then wipe off all traces of soda. NEVER USE ANY SOLVENTS, CLEANING COMPOUNDS, OILS, WAXES OR POLISHES ON PLASTIC CONTAINERS OR COVERS SINCE SUCH MATERIALS MAY ATTACK THE PLASTIC AND CAUSE IT TO CRAZE OR CRACK. DO NOT USE ANTI-CORROSION AEROSOL SPRAYS ON CONNECTIONS.

PURPOSE AND METHODS OF CHARGING (REFER TO TABLES I & II)

INITIAL CHARGE -

- A. **Lead-Antimony Types** (1.210 nominal specific gravity) - Give initial charge not later than 3 months after battery has been shipped and at highest voltage permitted by connected load. Table I shows various suggested voltages and corresponding time.
- B. **Lead-Calcium Types** (Check nominal specific gravity shown on nameplate on top of cells before proceeding.) Charge at highest voltage per cell permitted by connected load (equalize value if possible) until voltage of lowest cell stops rising and then continue for an additional 24 hours. If lead-calcium cells are to be floated at the recommended voltage they will automatically receive their initial charge at this voltage, providing they have not been on open circuit for more than six months. If on open circuit longer than six months they should be given an extended equalizing charge. Contact your local C & D representative or the C & D Technical Services Department for more information.

the Initial Charge from a voltage-regulated dc supply bus at the values in Tables I and II.

(Use recommended float voltage value unless other circuit components make it necessary to use the minimum float voltage values.) Check panel voltmeter against a known standard annually and calibrate if necessary.

EQUALIZING CHARGES - Compensate for irregularities in floating. Equalize charges are also required if cells reach critical voltages listed in Table II. Raise bus voltage to values shown in Tables I & II. Continue charge at these elevated values until lowest cell reads within 0.05 volts of the average of the cells in the lead calcium battery. Lead-antimony cells are equalized regularly at intervals of one to three months and are charged at equalize potential for 8 to 24 hours.

FINISH RATES - Normal finish rates are 5A/100 AH of the 8 Hour Capacity or 6A/100 AH of the 3 Hour Capacity. Finish rate currents are utilized in constant current charging for initial charging of dry charged cells and special remedial charging techniques. Float and equalize currents are considerably lower current values.

FLOAT CHARGING - Float batteries continuously after

TABLE I - LEAD-ANTIMONY CELLS

CHARGE VOLTAGE PER CELL (VPC) (1.210 SPECIFIC GRAVITY)			
INITIAL		FLOAT VPC	EQUALIZE VPC
VPC	HOURS		
2.39	40	2.15 to 2.17	2.33 for 8 to 24 hrs.
2.36	60		
2.33	110		
2.30	160		
2.24	210		

TABLE II - LEAD-CALCIUM CELLS

CHARGE VOLTAGE PER CELL (VPC)				
SP. GR. OF CELLS	FLOAT VPC		INITIAL/EQUALIZE (VPC)	
	MIN.	NOMINAL	CRITICAL CELL VOLT.	NOM. VPC
1.210	2.17	2.20-2.25	2.13	2.33-2.38
1.225	2.18	2.22-2.27	2.15	2.36-2.40
1.250	2.20	2.25-2.30	2.18	2.38-2.43
1.275	2.23	2.29-2.34	2.20	2.40-2.46
1.300	2.27	2.33-2.38	2.23	2.45-2.50

Figure 6.5-2. Installation and Maintenance Data

6.6 Operations & Maintenance

6.6.1 Recommended Spares Complement

A limited spares complement is recommended as follows:

P.V. Modules	Spares not recommended.
Batteries	Spares not recommended.
Power Control Panel	Spare regulator card, spare LM card, spare ground faulty relay assembly.
Connectors	10 percent spare Supercons.
Fuses	400 percent
Structures/Foundations	Spares, with the exception of small hardware, not recommended.
Intermodule Jumpers	10 percent (including Solarloks).
Battery Cables	Bulk cable, 10 percent, consistent with Supercon spares.
Contactors/Power/Snubbers/ Circuit Breakers	10 percent bulk spares, excluding power switching assemblies.
Power Switching Assemblies	1 spare PSA for each 4 power units.
MOV's/Transient Supressor	10 percent.
Power Diodes/IC Regulator Assemblies	100 percent.
Miscellaneous Power Control Panel Components	10 percent, or minimum of 1 for low population items.

6.6.2 Design Interchangeability

All functional electronic modules, such as the regulator and the load management control printed circuit cards, are completely interchangeable. After replacement, minor adjustments, such as peaking, recalibration, reset of hysteresis, etc., may have to be made to accommodate specific load profiles, relative battery age, and possibly the particular power input/power output budget.

All major subassemblies, the Power Switching Assemblies, and the PU power control cabinet itself are completely interchangeable with like assemblies. The Power Control Panel (PCP) and the Power Output Panel (POP) are likewise fully standardized and interchangeable.

All cells/battery modules of a particular manufacture and with identical service history are interchangeable.

All photovoltaic modules will be interchangeable within the specified performance tolerances. In the interests of maximizing the output of each string, premium output modules should be grouped into corresponding (10 series modules per string) premium strings, with the mid-distribution as well as the lower-acceptable limit devices arranged in 10 unit series strings of lower corresponding power output.

All bulk cable, mechanical hardware, and electrical fittings are completely interchangeable. All module to module connector links are standard. Serpentine links are interchangeable only with identically dimensioned units. With the exception of fabricated items and unique assemblies, no factory "specials" or nonstandard components are employed. Use of limited life items is avoided, except in the case of batteries, fuses, etc.,

6.6.3 Recommended Maintenance Apparatus

The below listed apparatus and instruments are recommended for efficient conduct of both scheduled and unscheduled maintenance; figure numbers referring to supplemental specification Control Drawings are given opposite the particular item.

- o Maintenance Test Box for Array Modules/Series Strings
- o Hall Effect Current Gun
- o Portable Digital Multimeters, (Ruggedized/shockproof: Beckman or FLUKE)
- o Industrial Electrical Test Set (Extended Range)
- o Electricians Tool and Repair Materials Kit.
- o Light Structural Tool Kit.
- o Battery Maintenance Kit (Figure 6.5-2 : Installation and Maintenance Data).

6.7 Life Cycle Cost (LCC) of the Final Design

The procedures for generating the LCC for the final design system were the same as those performed and described earlier for Life Cycle Costing of the conceptual and preliminary designs. Cost details were generated under the same assumptions as listed for the LCC of the preliminary design effort and included in Section 5.5

In addition to the assumptions described in the preceding paragraphs and quantified in the final design LCC, are those direct charge costs involving selected activities of engineering and program management. These costs as the result of their unique applications directly related to the product sale.

The costs associated with Engineering and Program Management were determined from the following:

1. The system designs are firm, preproduction proof of design modules have been verified, and the factory is capable of manufacturing PV systems at an annual rate of one megawatt.
2. The average system size manufactured and sold is two kilowatts, yielding 500 systems per year.
3. Cost for staging of systems at the Port of Entry of foreign countries is the responsibility of the customer.
4. To handle field problems arising from deployed systems, a sustaining engineering effort is required. It is assumed that during the twenty year life of the system, and average of two technical field problems will require engineering solutions for each system deployed. Each engineering solution will require an average of two person-hours.

Cost: $2 \text{ Hrs} \times \$28/\text{Hr} \times 2 \text{ Solutions} = \112 per system.

5. Product improvements to the basic product in production result from a variety of stimuli. Recommendations from the field relating to system quality and performance constitute perhaps the largest source of "needs" to improve the product. It is estimated that each year an average of six such product improvements will be implemented, and that each improvement will require approximately thirty hours of engineering type labor for implementation into the unit being produced.

Cost: $\frac{30 \text{ Hrs} \times \$28/\text{Hr} \times 6/\text{yr}}{500 \text{ sys/yr}} = \10.08 system.

6. The systems being produced are modular in size, ranging from a fraction of a kilowatt to sixteen kilowatts. Each system being sold must be sized by the factory technical staff to accommodate the user load needs and site specific climatic effects. It is assumed that each of these system size determinations will require four hours.

Costs: $4 \text{ hrs} \times \$28/\text{Hr} = \$112/\text{system.}$

For the above six items, the total adjusted twenty year life cycle cost is

\$234 per two kW system and
\$117 per one kW system.

Cost details for the final design for each of the major BOS elements are shown in Table 6.7-1 for one kW, for kW, and sixteen kW. Included as an addition to the list of BOS elements is the item "Shipping." This item was introduced into the system life cycle costs details to examine the cost impact brought on by shipping the systems to a remote site.

Table 6.7-1

Life Cycle Costs Details of Final Design BOS Elements

BOS ELEMENT	<u>\$/M²</u>		
	<u>1 KW</u>	<u>4 KW</u>	<u>16 KW</u>
1. Structures & Foundations	41.53	40.23	40.20
2. Site Protection	9.34	9.04	8.65
3. Array & Power Wiring	13.90	26.39	28.32
4. Power Controller	200.70	172.91	205.00
5. Battery Subsystem	1133.56	1133.56	1133.56
6. Electrical Protection & Safety*	11.45	9.51	6.50
7. Perimeter Security	137.49	59.13	29.51
8. Operations and Maintenance	535.19	481.42	545.59
9. Transportation (except Batteries)	33.80	29.62	23.49
10. Shipping to Remote Site**	42.24	39.07	36.73
11. Program Management	15.77	15.77	15.77
TOTALS	2174.97	2016.6	2073.32

* Does not include lightning protection

** Does not include batteries

7.0 ENGINEERING DRAWINGS

SEP 11305	TROUGH
SEP 11306	TROUGH ASSY. DETAILS
SEP 11307	TROUGH ASSY.
SEP 11318	SOLAR PANEL ASSY.
SEP 11358	POWER CONTROLLER ENCLOSURE
SEP 11360	POWER SWITCHING MODULE (PSM)
SEP 11363	POWER OUTPUT PANEL (POP)
SEP 11369	MODULARIZED POWER CONTROLLER SCHEMATIC
SEP 11389	ARRAY STRUCTURES ASSY.
SEP 11390	SUPPORT BATTERY
SEP 11391	CHANNEL, SIDE SUPPORT
SEP 11392	LEG, TELESCOPING
SEP 11414	MOTHER BOARD SCHEMATIC
SEP 11415	SCHEMATIC OF COMPOSITE C/R & L/M PC CARD
SEP 11416	CONTROL PANEL LAYOUT
SEP 11417	CONTROL PANEL DETAILS

7-2

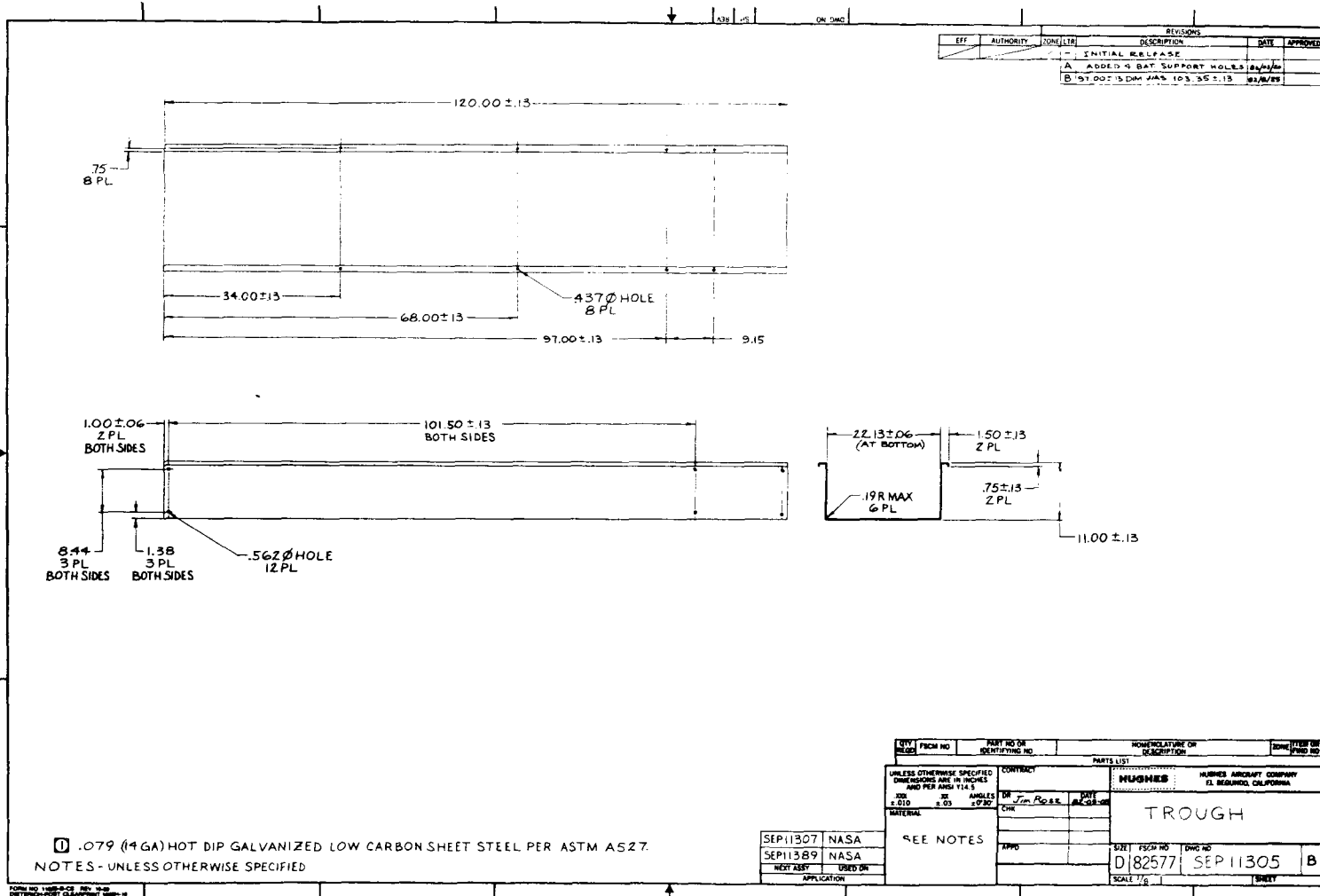

REV	AUTHORITY	SCALE	DATE	APPROVED
1				
INITIAL RELEASE				
A ADDED 4 BAY SUPPORT HOLES 8/14/88				
B 1ST 0.02 IN DIM WAS 103.35 ± .13 8/18/88				

QTY	FROM NO	PART NO OR IDENTIFYING NO	MANUFACTURE OR IDENTIFYING NO	DATE	ENTER BY
PARTS LIST					
UNLESS OTHERWISE SPECIFIED DIMENSIONS ARE IN INCHES AND PER ANSI Y14.5			CONTRACT		
TOLERANCES			MUGNIE		
.001			HUGHES AIRCRAFT COMPANY		
.005			EL SEGUNDO, CALIFORNIA		
.010			TROUGH		
.015			SEE NOTES		
.030			DATE		
.060			CHK		
.125			APPD		
.250			SIZE		
.500			PART NO		
1.000			DWG NO		
2.000			D 82577		
4.000			SEP 11 305		
8.000			B		
16.000			SCALE 1/6		
32.000			SHEET		

FORM NO. 148-PLCE REV. 3-68
DETROIT-WOODWARD CLERKSON 10-11-68

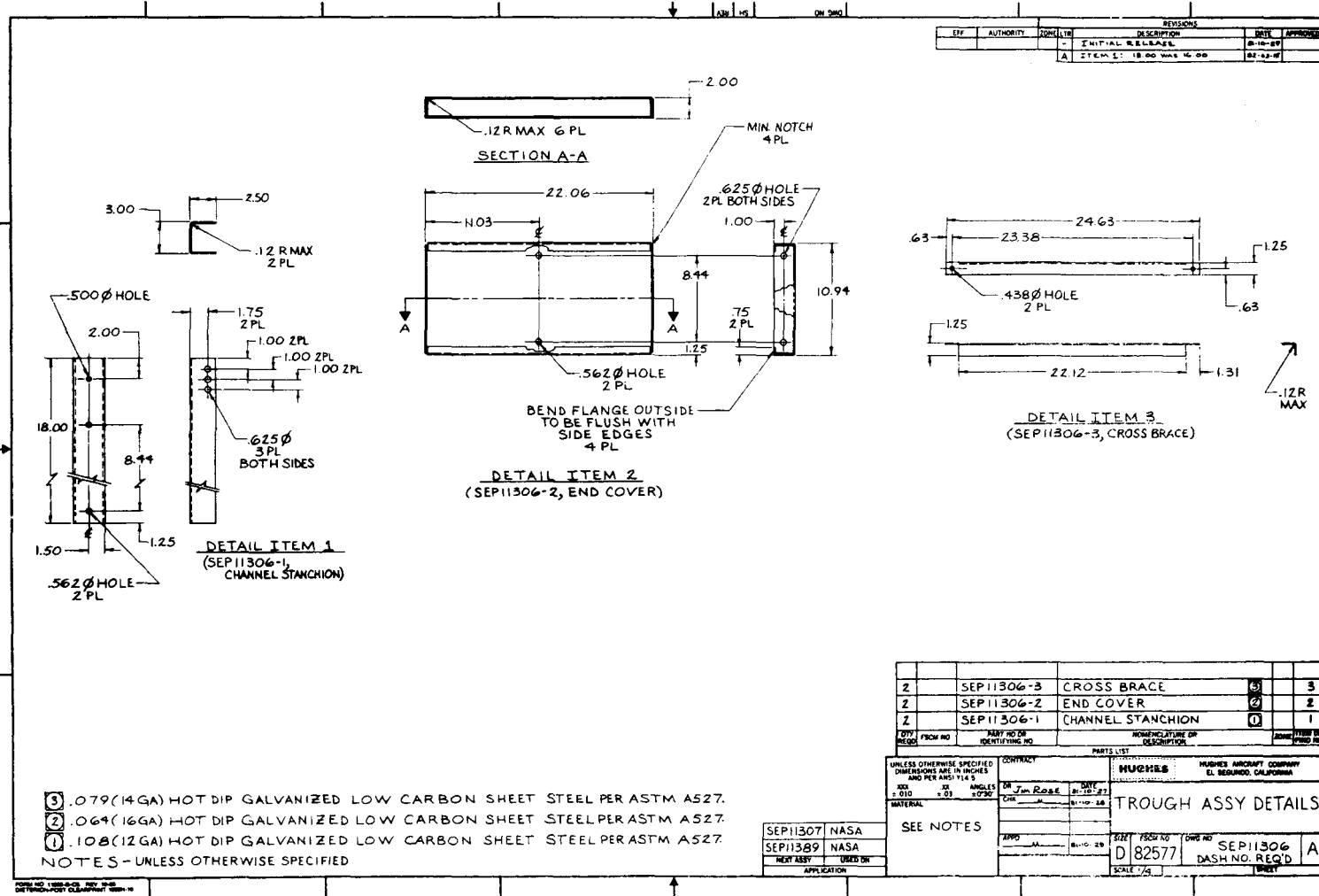

REV	AUTHORITY	DATE	DESCRIPTION	BY	APPROVED
-			INITIAL RELEASE	B-10-87	
A			ITEM 1: 18.00 WAS 14.00	07-22-87	

- ③ .079 (14GA) HOT DIP GALVANIZED LOW CARBON SHEET STEEL PER ASTM A527.
 - ② .064 (16GA) HOT DIP GALVANIZED LOW CARBON SHEET STEEL PER ASTM A527.
 - ① .108 (12GA) HOT DIP GALVANIZED LOW CARBON SHEET STEEL PER ASTM A527.
- NOTES - UNLESS OTHERWISE SPECIFIED

QTY	FROM NO	PART NO OR IDENTIFYING NO	MANUFACTURE OR DESCRIPTION	APPROVED BY	DATE
2		SEP11306-3	CROSS BRACE	③	3
2		SEP11306-2	END COVER	②	2
2		SEP11306-1	CHANNEL STANCHION	①	1

UNLESS OTHERWISE SPECIFIED DIMENSIONS ARE IN INCHES AND PER ANSI Y14.5	CONTRACT	HUGHES	HUGHES AIRCRAFT COMPANY EL SEGUNDO, CALIFORNIA
FRAC OR ANGLES ±.010 ±.030	DR Jm Rose	DATE 8-10-87	
		DATE 8-10-88	
MATERIAL	SEE NOTES	APPROV	SCALE 1/4"
SEP11307 NASA		DATE 8-10-88	
SEP11389 NASA			
NEWT ASSY	USED ON	ITEM FROM NO	SEP11306
APPLICATION		DASH NO. REQ'D	D 82577
			A

7-4

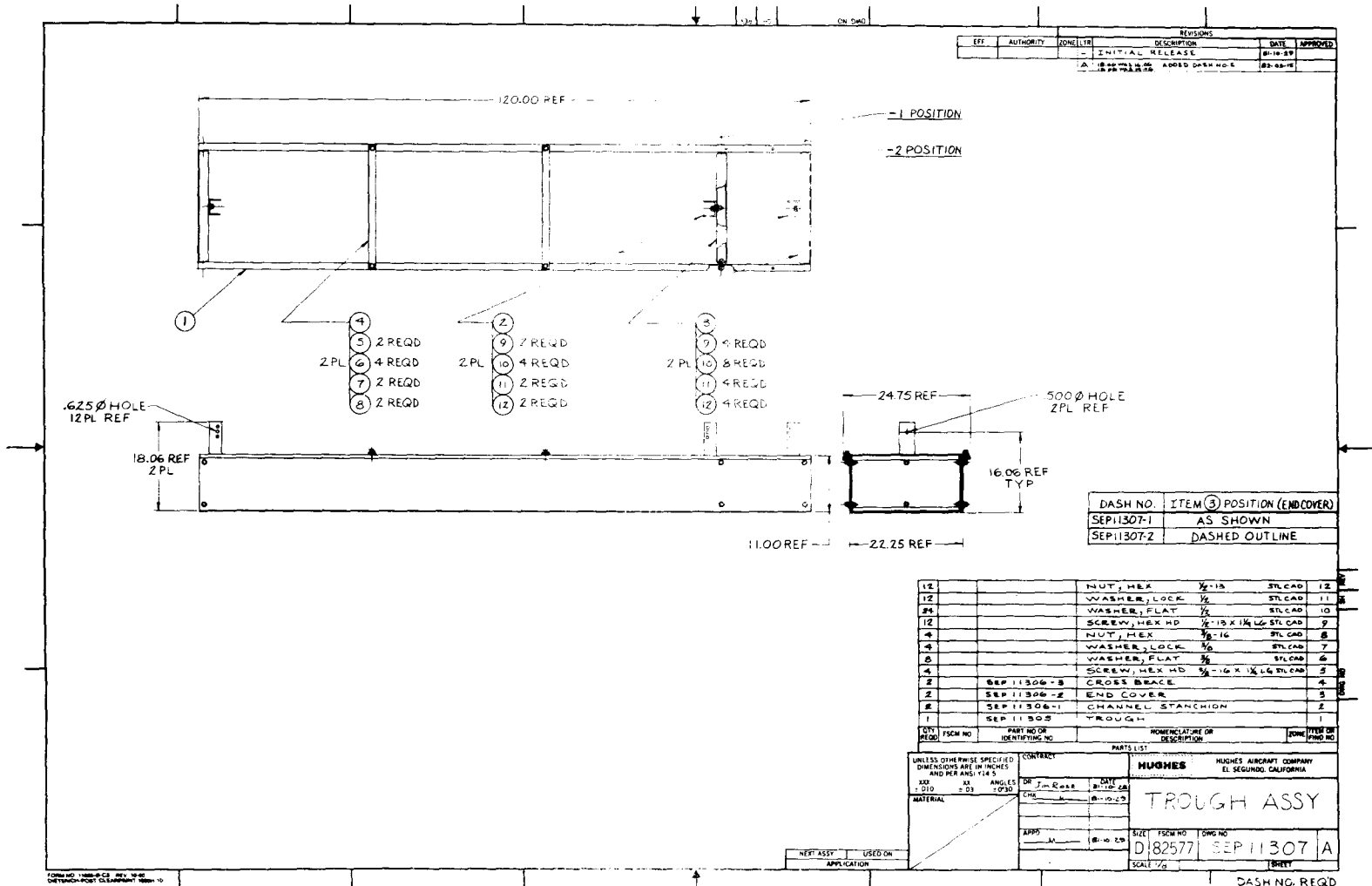

7-5

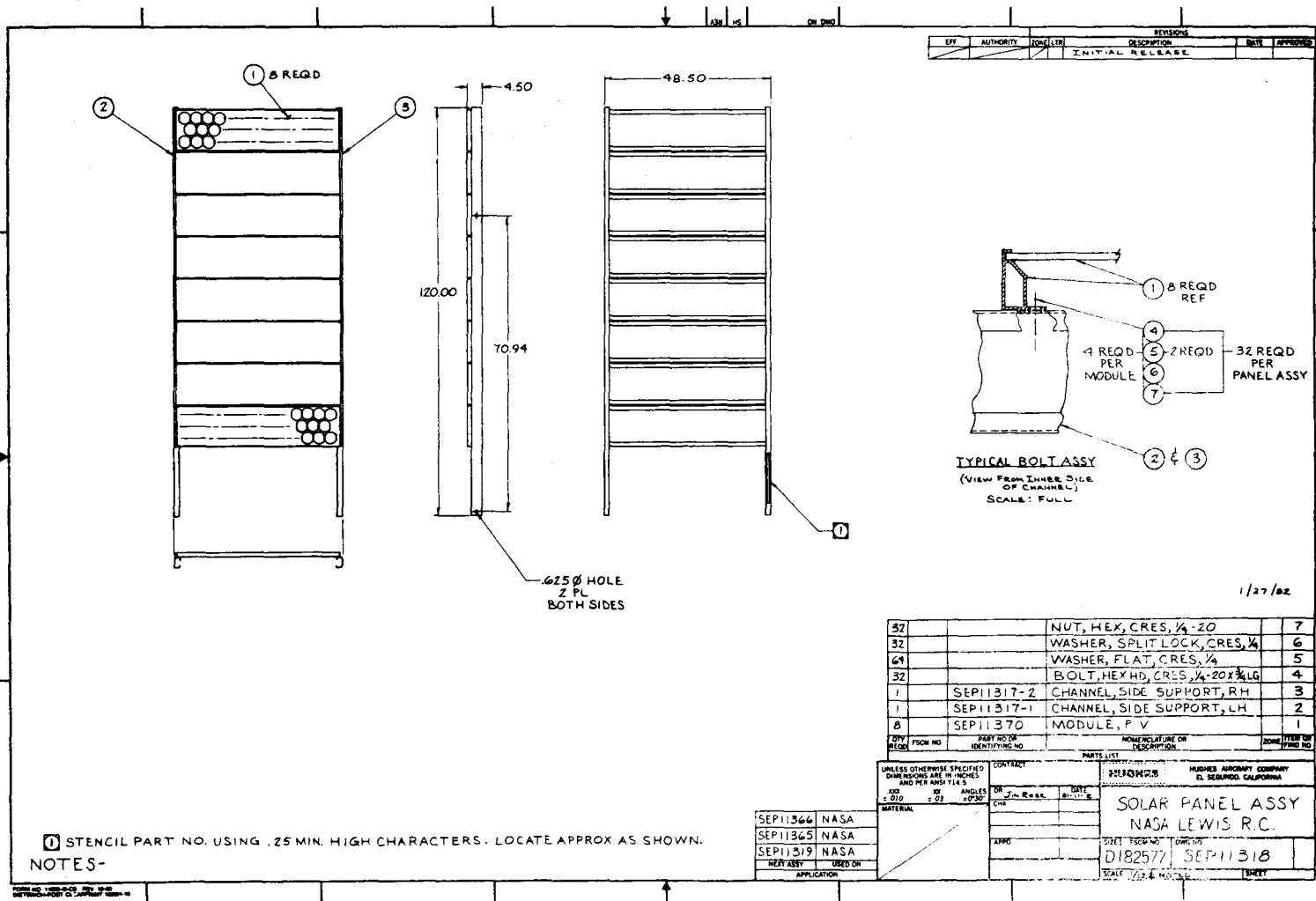

REVISIONS				
REV	AUTHORITY	DATE	DESCRIPTION	BY
1			INITIAL RELEASE	

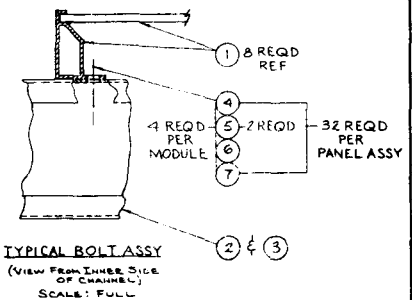

1/27/62

QTY	FROM NO	PART NO OR IDENTIFYING NO	DESCRIPTION	UNIT	REQD
32			NUT, HEX, CRES, 1/4-20		7
32			WASHER, SPLIT LOCK, CRES, 1/4		6
64			WASHER, FLAT, CRES, 1/4		5
32			BOLT, HEX HD, CRES, 1/4-20x3/16		4
1	SEP11317-2		CHANNEL, SIDE SUPPORT, R.H.		3
1	SEP11317-1		CHANNEL, SIDE SUPPORT, L.H.		2
8	SEP11370		MODULE, P V		1

UNLESS OTHERWISE SPECIFIED DIMENSIONS ARE IN INCHES AND PER ANGLES 5		CONTRACT		PARTS LIST	
FIN	OF	NO	DATE	REV	DATE
±.010	±.015	SEP11366		1	1/27/62
±.010	±.015	SEP11365		1	1/27/62
±.010	±.015	SEP11319		1	1/27/62
		SEP11364	NASA		
		SEP11365	NASA		
		SEP11319	NASA		
		SEP11366	NASA		

SOLAR PANEL ASSY
NASA LEWIS R.C.
D182577 SEP11318
SCALE 1/2" = 1"

NOTES-
1 STENCIL PART NO. USING .25 MIN. HIGH CHARACTERS. LOCATE APPROX AS SHOWN.

FORM NO. AIR-1600 (REV. 11-60) PREPARED BY THE AIR FORCE

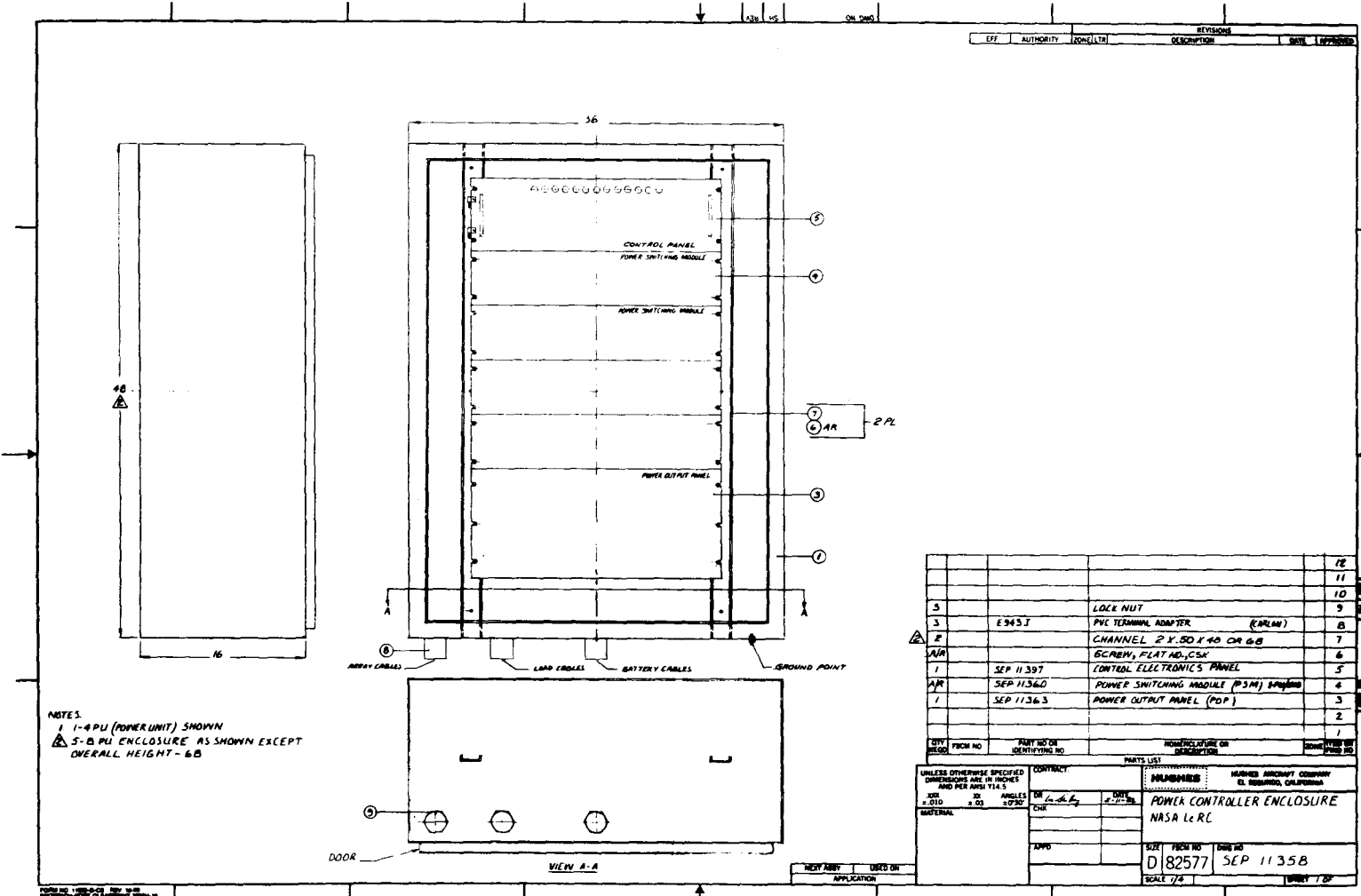

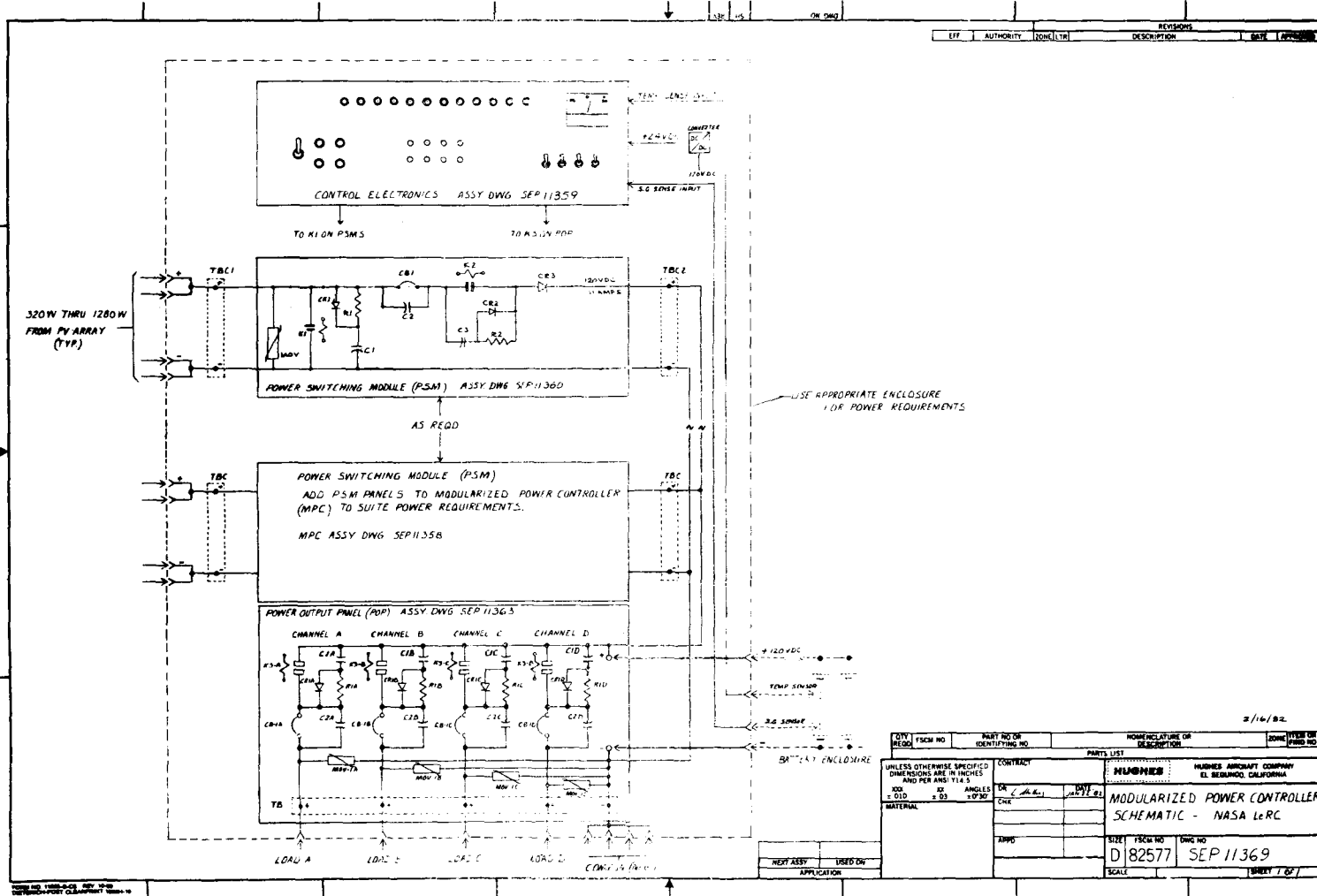

QTY	TSCM NO	PART NO OR IDENTIFYING NO	NOMENCLATURE OR DESCRIPTION	ZONE (USE IN PART NO)
			NUMER	
UNLESS OTHERWISE SPECIFIED DIMENSIONS ARE IN INCHES AND PER ANG 114.5			HUNTER AIRCRAFT COMPANY EL SEGUNDO, CALIFORNIA	
CONTRACT	DATE	DR	MODULARIZED POWER CONTROLLER SCHEMATIC - NASA LeRC	
ANGLES ± 0.5°	DATE	CHE	SIZE	TSCM NO
± 0.30"			D	82577
			DWG NO	SEP 11369
			SCALE	SHEET 1 OF 7

7-10

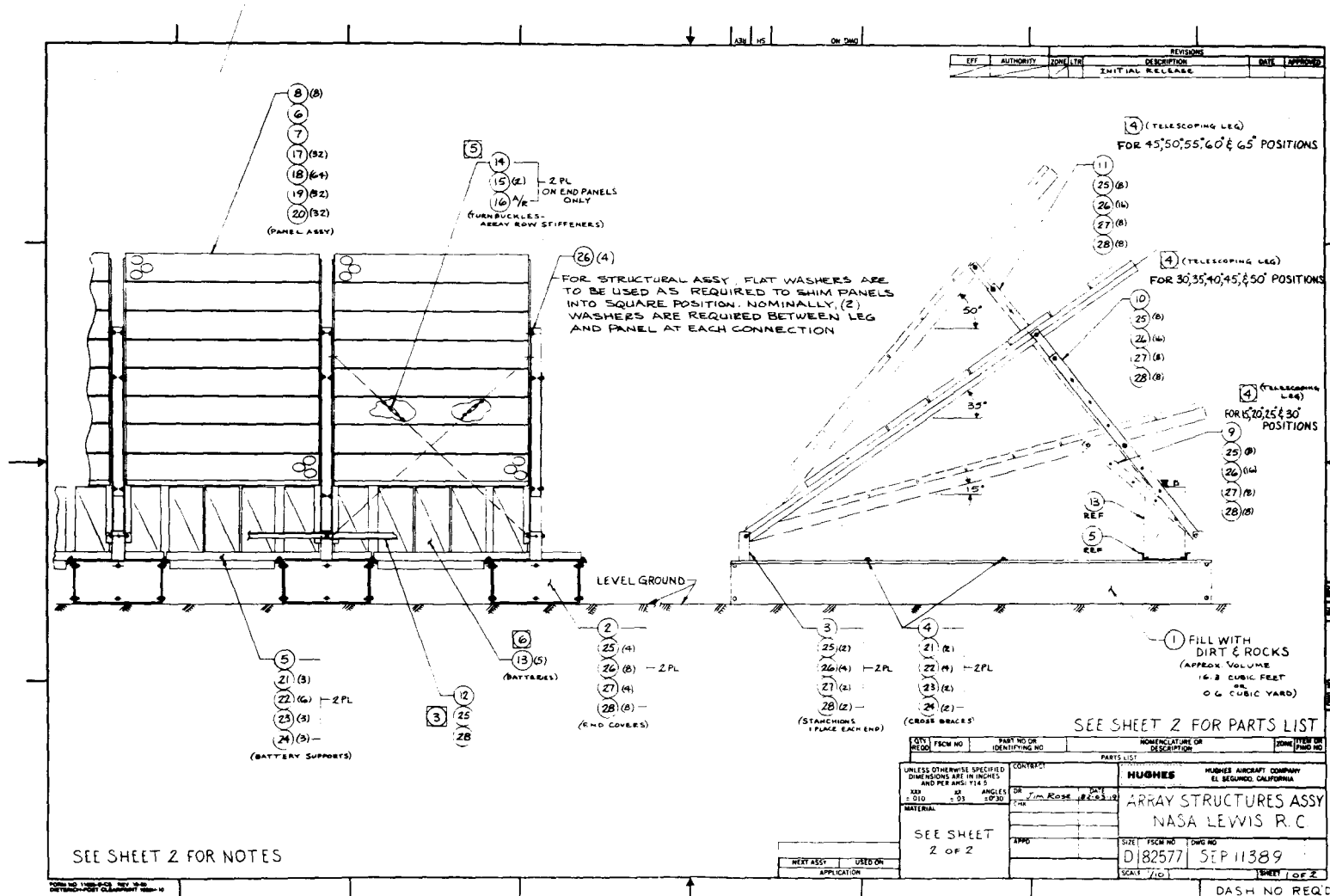

7-11

NOTES: UNLESS OTHERWISE SPECIFIED

- 1 ALL PART QUANTITIES LISTED ARE PER PANEL ASSY OR PER PANEL INTERVAL EXCEPT (12)(14)(15)(16).
- 2 PRIOR TO STRUCTURE ASSY, LEVEL GROUND SURFACE TO WITHIN (1) INCH OF A DATUM PLANE.
- 3 SMALL ALIGNMENT ANGLE (2) TO BE USED TO SPACE FRONT END OF TROUGHS DURING ASSY ONLY.
- 4 TO RAISE PANELS AFTER ASSY, BOLT SIDE CHANNELS (2)(7) TO FRONT STANCHIONS (3), BOLT LOOSE TELESCOPIC LEGS (2)(10) OR (11) TO SIDE CHANNELS AT TOP AND REAR STANCHIONS AT BOTTOM, RAISE PANELS TO REQ'D ANGLE AND ADD BOLTS TO TOP & BOTTOM OVERLAPPING HOLES.
- 5 FOR ARRAY ROW STIFFENERS: ADD ANGLE CLIPS (15) AT BOLTED LEG JOINTS, 4 PLACES, LOOP WIRE ROPE (16) THRU ANGLE CLIPS AND TURNBUCKLES (14) AND SECURE LOOPS WITH TWO (2) WIRE ROPE CLIPS (29) PER LOOP. TIGHTEN TURNBUCKLES TO REMOVE WIRE ROPE SLACK. ASSEMBLE HARNESSSES AS SHOWN TO ARRAY ROW ENDS ONLY.
- 6 CAUTION: SINGLE FREE STANDING BATTERIES ARE EASILY UPSET; BATTERIES SHOULD BE BANDED OR ELECTRICALLY WIRED TOGETHER AT ALL TIMES.

EFF	AUTHORITY	ISSUE DATE	DESCRIPTION	DATE	APPROVED
-----	-----------	------------	-------------	------	----------

5	16	16	# 3465T26	WIRE ROPE CLIP	MCMASTER-CARR	29
	20	20		NUT, HEX, 1/2-13	CAD PL	28
	20	20		WASHER, SPLIT LOCK, 1/2	CAD PL	27
	44	44		WASHER, FLAT, 1/2	CAD PL	26
	20	20		SCREW, HEX HD, 1/4-13 1/4 LG	CAD PL	25
	10	10		NUT, HEX, 3/8-16	CAD PL	24
	10	10		WASHER, SPLIT LOCK, 3/8	CAD PL	23
	20	20		WASHER, FLAT, 3/8	CAD PL	22
	10	10		SCREW, HEX HD, 1/8-16 X 1 LG	CAD PL	21
	32	32		NUT, HEX, 1/4-20	CRES	20
	32	32		WASHER, SPLIT LOCK, 1/4	CRES	19
	64	64		WASHER, FLAT, 1/4	CRES	18
	32	32		SCREW, HEX HD, 1/4-20 X 1 LG	CRES	17
5	1/2	1/2	# 345BT17	WIRE ROPE 1/8 DIA	MCMASTER-CARR	16
	4	4	# 3053T2	ANGLE CLIP	MCMASTER-CARR	15
	2	2	# 2999T53	TURNBUCKLE, 3/8	MCMASTER-CARR	14
	5	5	# 3KCPSA-5	BATTERY, 3 CELL, 131lbs, C & D		13
3	1	1	SEP11308-2	SMALL ALIGNMENT ANGLE		12
	1		SEP11392-3	LEG, TELESCOPING, 40° TO 65°		11
	1		SEP11392-2	LEG, TELESCOPING, 25° TO 50°		10
	1		SEP11392-1	LEG, TELESCOPING, 15° TO 30°		9
	8	8		MODULE		8
	1	1	SEP11391-2	CHANNEL, SIDE SUPPORT R.H.		7
	1	1	SEP11391-1	CHANNEL, SIDE SUPPORT L.H.		6
	2	2	SEP11390	SUPPORT, BATTERY		5
	2	2	SEP11306-3	CROSS BRACE		4
	2	2	SEP11306-1	STANCHION		3
	2	2	SEP11306-2	END COVER		2
	1	1	SEP11305	TROUGH		1

DASH NO.	PANEL ANGULAR POSITIONS
SEP11389-1	15°, 20°, 25°, 30°
SEP11389-2	30°, 35°, 40°, 45°, 50°
SEP11389-3	45°, 50°, 55°, 60°, 65°

1	QTY	REV	FRM NO	REV NO OF IDENTIFYING NO	NOMENCLATURE OR IDENTIFYING NO	ZONE	TYPE OF PART NO
-3	-2	-1					

UNLESS OTHERWISE SPECIFIED DIMENSIONS ARE IN INCHES AND PER ANSI #1.4

REV 01 ANGLES 1030

DR Tm Rose DATE 02-08-10

CHK

MATERIAL

SEE P/L ABOVE

APPRO

CONTRACT

HUGHES HUGHES AIRCRAFT COMPANY EL SEGUNDO, CALIFORNIA

ARRAY STRUCTURES ASSY (SEE SH1 FOR PANEL DETAILS)

SHEET FROM NO 040 NO D182577 SEP11389

SCALE 1:1 SHEET 2 OF 2

FORM NO 1100-B-C REV 10-60 DETACHED FROM CLEARPRINT 1000-10

DASH NO REQ'D

7-13

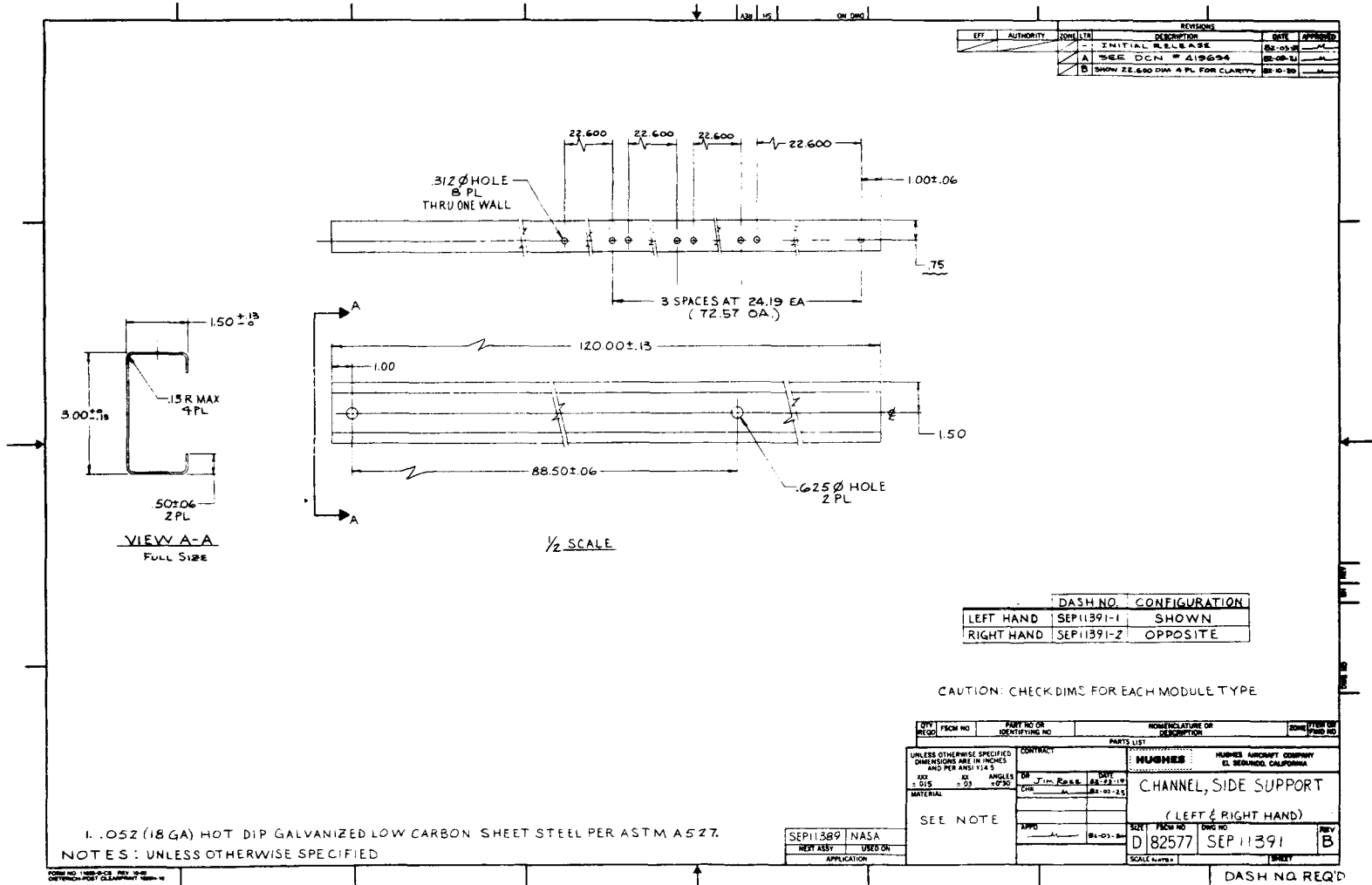

EFF	AUTHORITY	DATE	INITIALS	DESCRIPTION	REV	APPROVED
				INITIAL RELEASE	82-03-2	
				SEE DCN # A19694	82-03-1	
				SHOW 22.600 DIA 4 PL FOR CLARITY	82-10-20	

	DASH NO.	CONFIGURATION
LEFT HAND	SEP11391-1	SHOWN
RIGHT HAND	SEP11391-2	OPPOSITE

CAUTION: CHECK DIMS FOR EACH MODULE TYPE

1.052 (18 GA) HOT DIP GALVANIZED LOW CARBON SHEET STEEL PER ASTM A527.
 NOTES: UNLESS OTHERWISE SPECIFIED

SEP11389 NASA
 NEXT ASSY USED ON
 APPLICATION

QTY REQD	FROM NO	PART NO OR IDENTIFYING NO	NUMERATURE OR DESCRIPTION	QTY PER SET PART NO
UNLESS OTHERWISE SPECIFIED DIMENSIONS ARE IN INCHES AND PER ANSI Y14.5			CONTRACT	
KD : 015	AS : 03	ANGLES : 030	FOR : Jim Rose	DATE : 82-11-19
MATERIAL	SEE NOTE	DATE : 82-03-25	PARTS LIST	
			MUNHIES	
			MUNHIES AIRCRAFT COMPANY EL SEGUNDO, CALIFORNIA	
			CHANNEL, SIDE SUPPORT	
			(LEFT & RIGHT HAND)	
			SIZE	QTY
			D 82577	SEP11391
			SCALE	REV
				B

DASH NO REQ'D

7-17

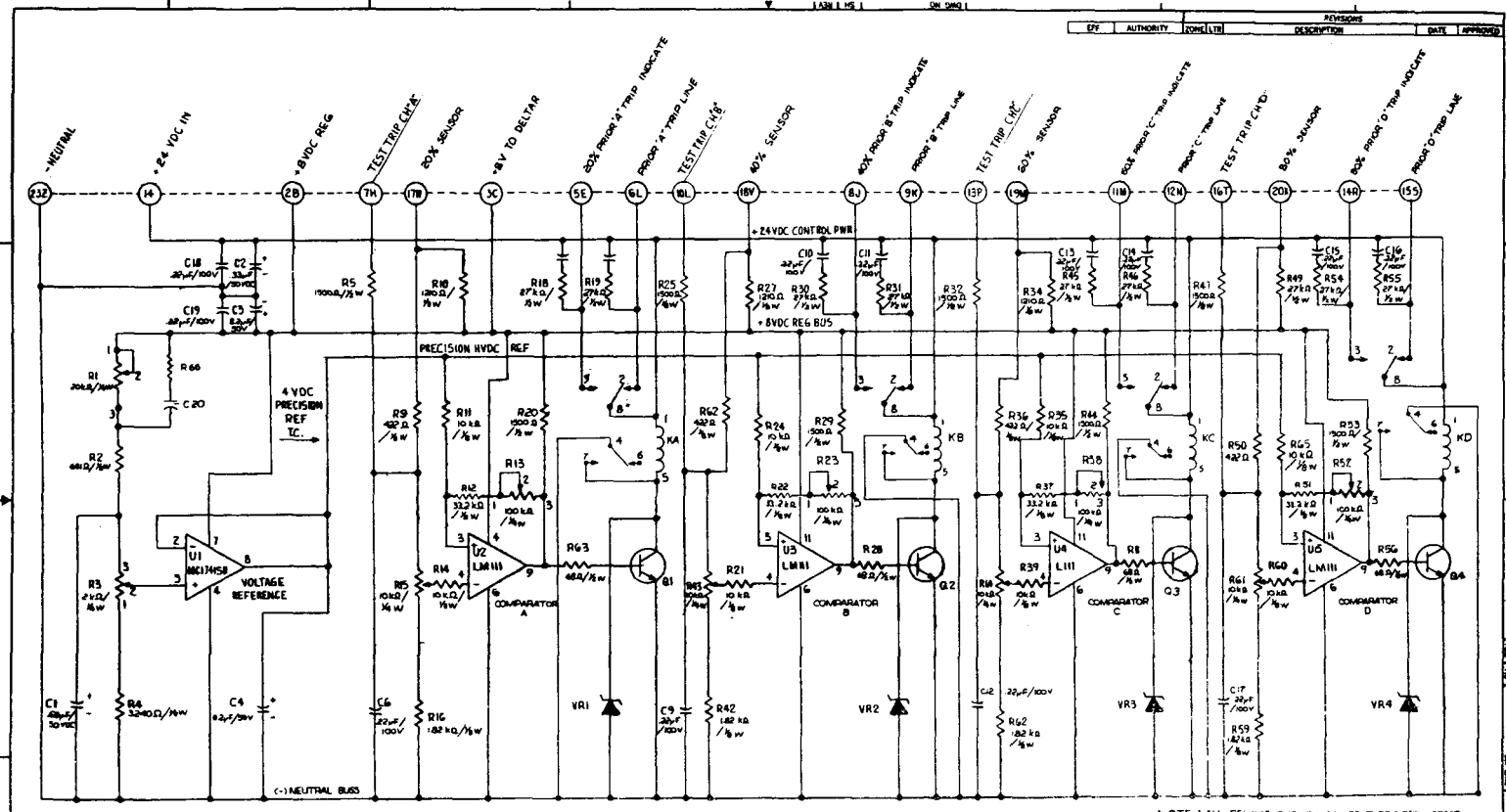

NOTE:
 KA, KB, KC, KD = HPS 110-24
 Q1, Q2, Q3, Q4 = 2N2270
 VR1, VR2, VR3, VR4 = IN62R44

LOAD/MANAGEMENT CONFIGURATION - OI

NOTE: ALL RELAYS SHOWN IN DE-ENERGIZED STATE

PROTOTYPE 83-04-13

HUGHES AIRCRAFT COMPANY EL SEGUNDO, CALIFORNIA CIRCUIT DESIGN	CONTRACT #45A-LEWIS POWER CONTROLLER SHEET 732H NO. 0 REV. 0	DWG NO. 82577 SEP-1945 SHEET 2 OF 3
---	--	---

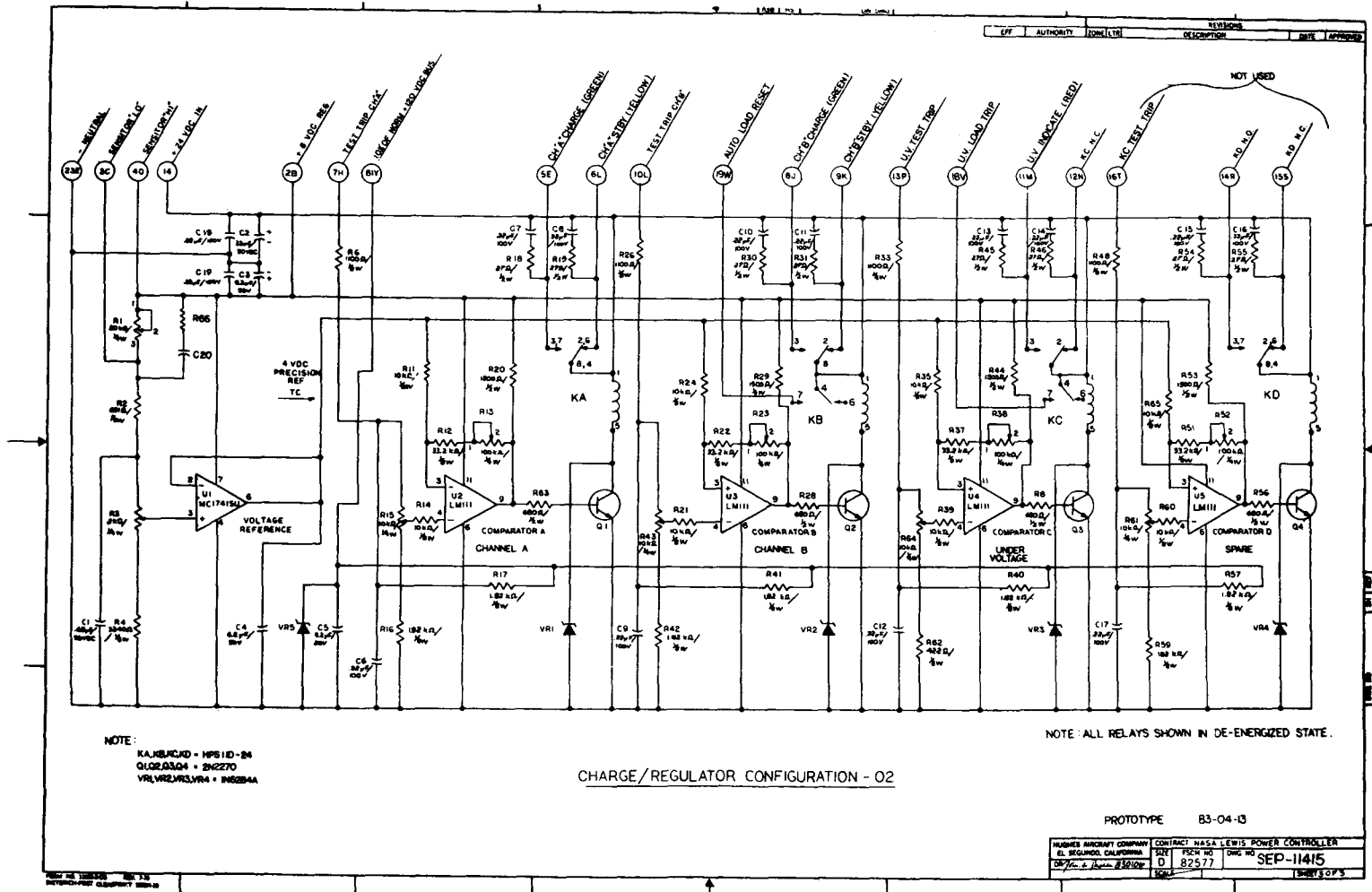

NOTE:
 KA, KB, KC, KD - MPS 110-24
 Q1, Q2, Q3, Q4 - 2N2270
 VR1, VR2, VR3, VR4 - IN6294A

CHARGE/REGULATOR CONFIGURATION - 02

NOTE: ALL RELAYS SHOWN IN DE-ENERGIZED STATE.

PROTOTYPE 83-04-13

NUMERICAL COMPANY EL SEGUNDO, CALIFORNIA 15775 S. Avenue #5500	CONTRACT NASA LEWIS POWER CONTROLLER TASK #24-70 D 82577	DWG NO SEP-14-15
--	--	---------------------

7-20

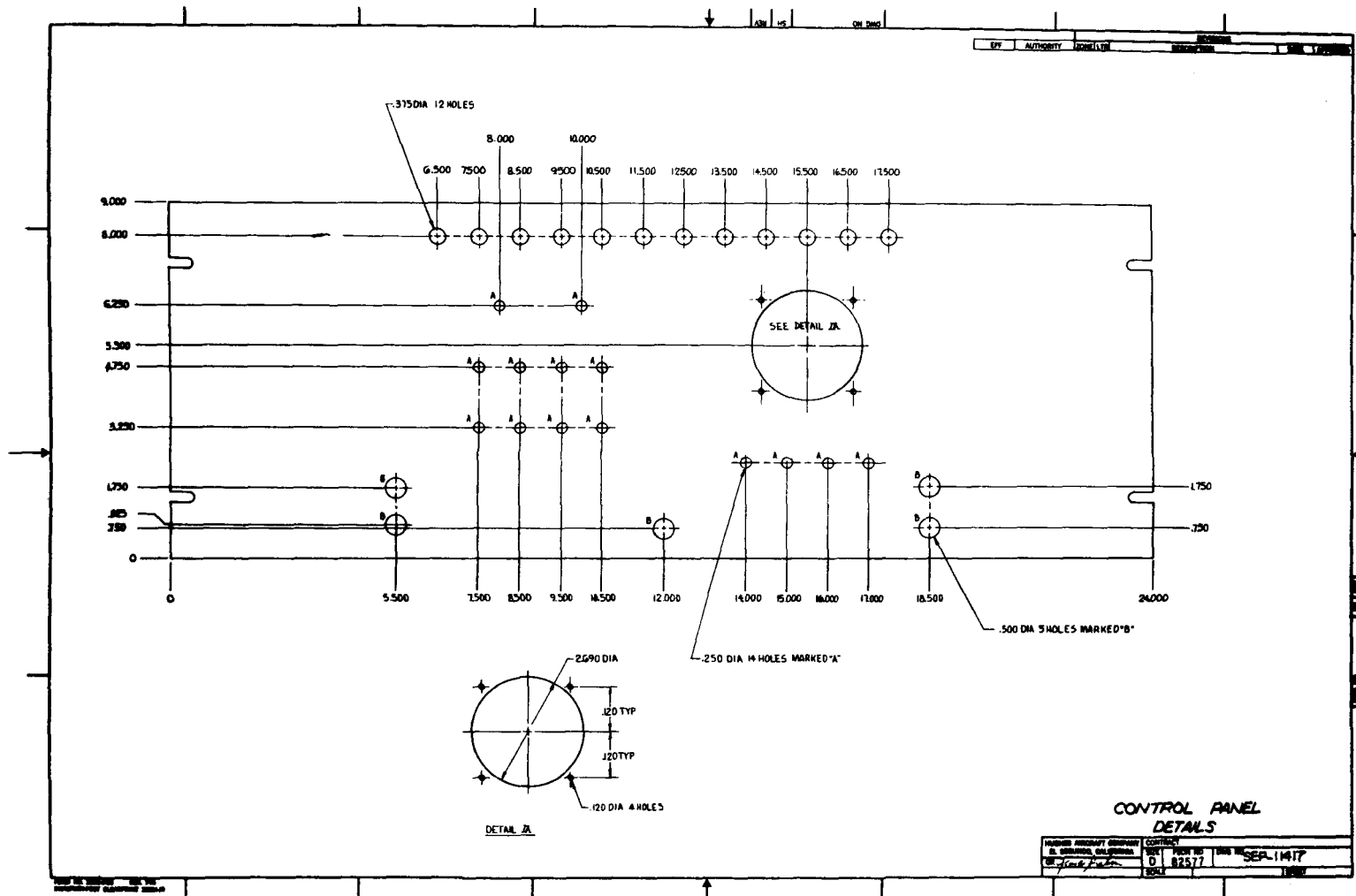

CONTROL PANEL
DETAILS

DESIGNED BY: [Signature]	CHECKED BY: [Signature]
DATE: [Signature]	DATE: [Signature]
NO. 82577	REV. 1417

APPENDIX A - PARAMETRIC MODELS OF KEY COMPONENTS OF CHARGER REGULATORS

The parametric cost models developed in this study utilized manufacturers data sheets and price lists in effect for January 1981. Prices were used which reflect purchases in quantities of 100-999 or 100-499 with original equipment manufacturers (OEM) discounts. An exclamation factor of 15% would better represent current (Jan 1982) prices.

The definition of service ratings of current and voltage on the charts and in the models deserve close attention by those using them:

A-1 Model Voltage Rating (V_{moc})

This is intended to be the maximum value of voltage the device will see in normal service, based on the array open-circuit voltage. The industry rating of V_{ceo} (for transistor), V_r (for diode), and V_{fom} (for thyristors) are each derated by 10% to yield the rating V_{moc} :

$$\begin{aligned}V_{moc} &= 0.9 V_{ceo} \\ &= 0.9 V_r \\ &= 0.9 V_{fom}\end{aligned}$$

The derating is intended to accommodate overvoltage devices and surge arrestors with the assumption that the peak voltage of such devices will not exceed 1.1 times the array open-circuit voltage.

A-2 Model Current Rating (I_{msc})

This is intended to be the maximum value of current the device will see continuously assuming short-circuit conditions of the array. There is no simple multiplier of industry ratings. For transistors I_{msc} is the collector current for $V_{cesat} = 1.0$ volts. In most cases this derates the I_c max value from 50-60%. This is done because higher

The variation of diode cost with voltage is not great in the range of interest and at the higher currents is a small fraction. This plus Figure 3-1 points out that there are really two cost models, one for currents from 10-60A and a second for currents 100-200A:

$$\begin{aligned} \$_{\text{diode}}(I,V) &= \quad \quad \quad \text{for } 10 \leq I \leq 60A \\ \$_{\text{diode}}(I,V) &= \quad \quad \quad \text{for } 100 \leq I \leq 200A \end{aligned}$$

In fact, there are few diodes rated between 60 and 100 amperes and they tend to be costly. The sharp break in price above 60A reflects both a lower volume of production and a greatly increased cost of the diode housing at the higher ratings.

A-3 Parametric Cost Model of a Thyristor

Figure IV-8 is a plot of thyristor unit prices-vs- I_{MSC} with voltage as a parameter. As was the case with the diodes, a sharp upward break in prices occurs as current rating increases. For the thyristors this break occurs at about 30A. It is worth noting that dissipation is higher in a thyristor than in a diode at the same current (assuming equal ratings). Further, thyristor case temperature is more critical than is diode temperature. There are three junctions in a thyristor and thermally they are nearly in series. A diode has only one junction, one side of which is brazed to the case. Thus it is not surprising that the 30A thyristor and 60A diodes represent the same break point to more expensive housings.

The models also appear useful for thyristors:

$$\begin{aligned} \$_{\text{thr}}(I,V) &= \quad \quad \quad \text{for } 10 \leq I \leq 30A \\ \$_{\text{thr}}(I,V) &= \quad \quad \quad \text{for } 50 \leq I \leq 180A \end{aligned}$$

When one considers that dissipation, at full rating, in a 60A diode is about 72 watts and in a 30 ampere thyristor 40 watts, there is some persuasion to set these as the maximum current that will be used and adjust the system configuration accordingly. The comparable figures for 100A diodes and 60A thyristors are 120 watts and 80 watts, respectively. This implies large and expensive heat sinks and adds markedly to the cost.

A-4 Parametric Cost Model of a Silicon Power Transistor

Figure IV-9 is a plot of transistor unit price-vs- V_{MOC} with I_{MSC} as a parameter. This change in plotting format resulted from the discovery that power transistor prices can best be scaled linearly with current and exponentially with voltage (almost the reverse of rectifiers and thyristors).

The paralleling of diodes or thyristors to increase current rating is in most cases not practical owing to the large heat release in ballast resistors needed to promote current sharing. On the other hand, transistors have significant gain and can be made to share current in parallel with only modest heat release.

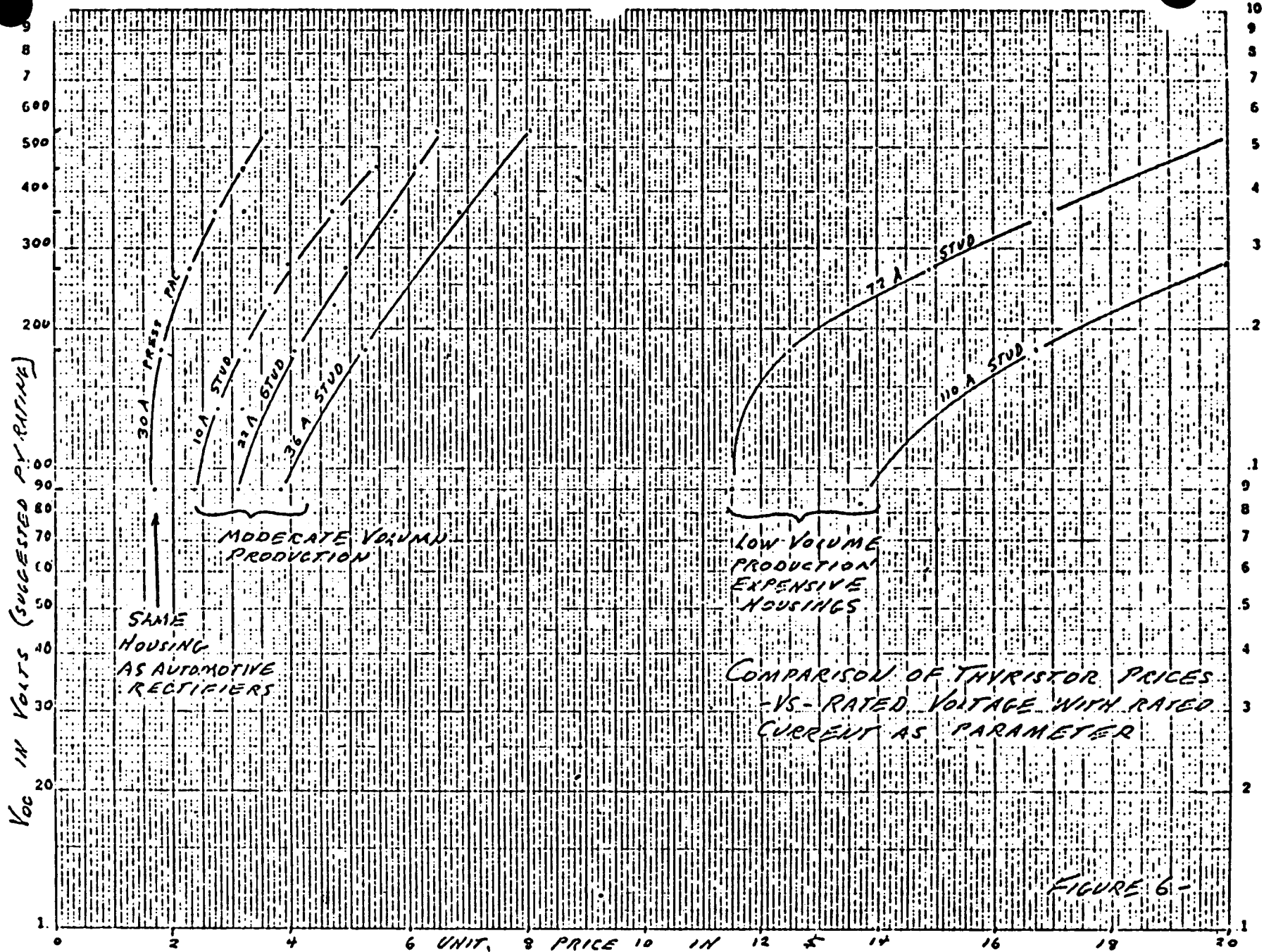

COMPARISON OF THYRISTOR PRICES -VS- RATED VOLTAGE WITH RATED CURRENT AS PARAMETER

FIGURE 6-

FIGURE IV-8. COMPARISON OF THYRISTOR PRICES-VS-RATED VOLTAGE WITH RATED CURRENT AS PARAMETER

(There is no extra parts cost as a small emitter resistor is advisable on even a single transistor to preclude thermal runaway.) In short, transistors can be paralleled. Thus if a given current rating represents a distinctly minimum cost per ampere, then higher ratings may be achieved by paralleling, i.e., a linear scale of cost with current. Examination of Figure IV-9 shows that this is distinctly the case:

It is cheaper to use 1-7.5A transistor than 2-3A transistors.
 It is much cheaper to use 3-7.5A transistors than 1-20A transistor.

The 7.5A transistor represents an excellent standardization point (or cost detente) as it is available in a wide range of voltages (40-270 volts). It also embodies a housing which is produced in very high volume for the audio, automotive and television industries.

The price of power transistors at all popular current ratings (3, 7.5, 20A) scales exponentially with voltage to a very close agreement. Thus:

$$\$_{xstr}(I,V) = N \frac{V_{mos}^{1.17}}{72} \qquad N = \text{integer (rnd up) of } \frac{I_{msc}}{7.5}$$

For a 7.5A transistor is highly accurate as can be seen from Figure IV-9.

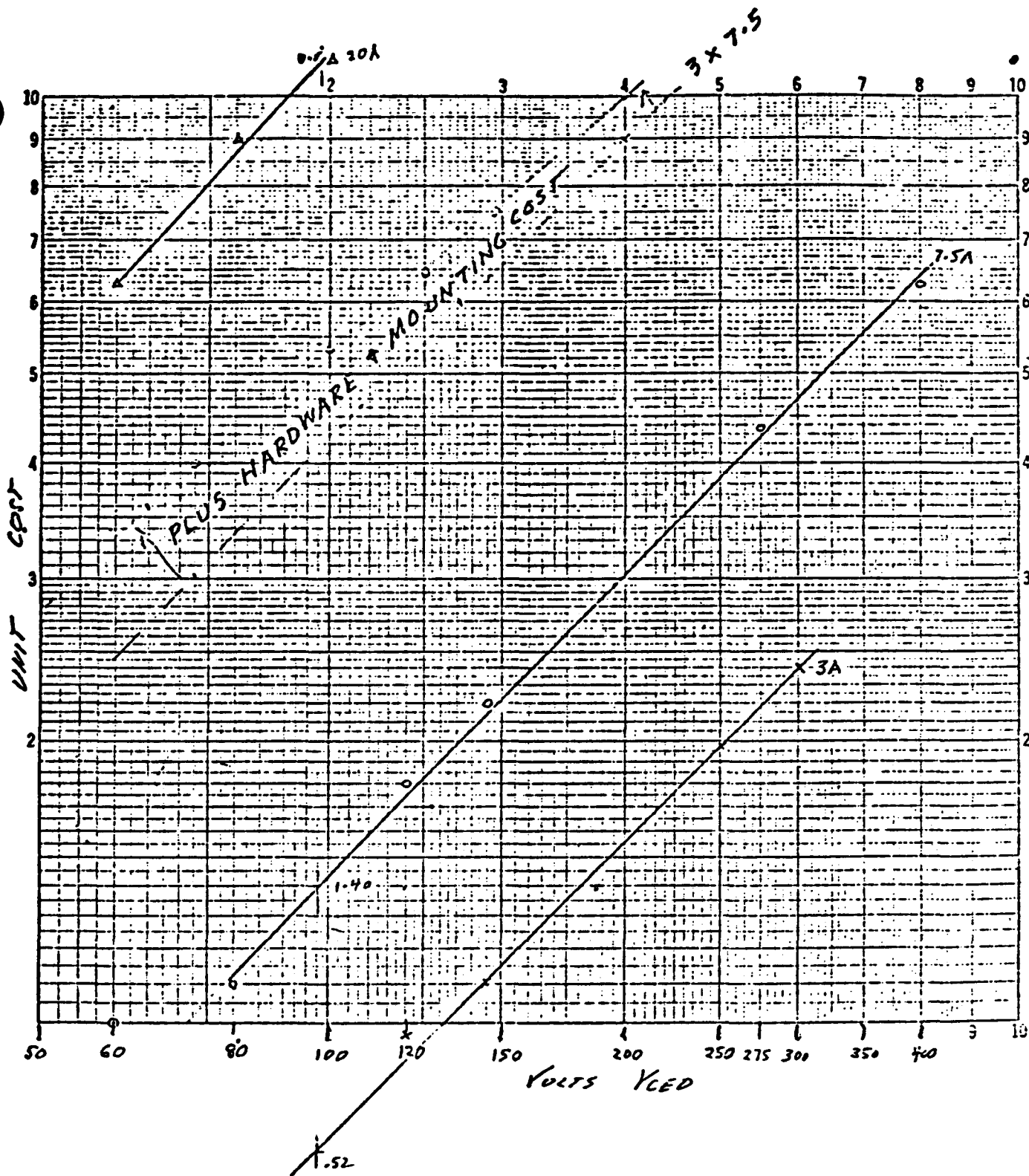

FIGURE IV-9. TRANSISTOR COST-VS-RATING

A-5. Parametric Cost Model for a Darlington Transistor

The Darlington transistor is actually two bipolar transistors of the same type plus two resistors and a reverse voltage diode clamp, all in a single housing. The chief advantage vis-a-vis a single bipolar transistor is the great reduction in driving current required to saturate the device. The sole disadvantage is the usually higher value of V_{cesat} which is necessary because the drive circuit has two base-emitter junctions in series with the base-collector junction of the first returned to a common collector connection. This weakness almost preclude the use of an non-relay bypassed Darlington in low voltage stress applications. Figure IV-10 compares Darlington prices to those of bipolar transistors, thyristors and diodes. In general, the Darlington represents a best buy compared to transistors. Again as with the transistor the most economical size is 8-10A. The cost model is, very simply:

$$\text{Cost} = \$1.50/\text{sc kW}$$

A-6. Power Contactors/Relays

There are essentially three ratings of devices in this class, 125 volt, 250 volt, 600 volt. The prices reflect the greatly increased difficulty of interrupting a direct current as the voltage increases. As example, consider the devices below. Each is the lowest price in its class in terms of \$/amp. All have 2 normally open contacts; they are available in other configurations. It is important to note that the below rating are those of the factory; they do not reflect the use of external snubbers.

Mfr - Type Nbr	<u>Current</u>			Price	\$/kW-Circuit
	(Each Contact)	Voltage			
	<u>A</u>	<u>V</u>	<u>\$</u>		
P&B MB	60	28	30		8.93
P&B PRD	10	125	14		5.60
Ward-Leonard 7400	22.5	250	156		13.86
Ward-Leonard 7400	45	250	220		9.78
Ward-Leonard 7400	90	250	270		6.00
C-H 80-6002	25	600	376		12.53
Westinghouse-M,MD	50	600	420		7.00
Westinghouse-M,MD	100	600	640		5.33
C-H 80-6002	150	600	1160		6.45

The 125 volt device as supplied by the factory, uses a permanent magnet blowout for the arc; the higher voltage units use blowout coils. The 28 volt unit uses no arc blowout, but is too low in voltage for general use, without the use of outboard snubbers.

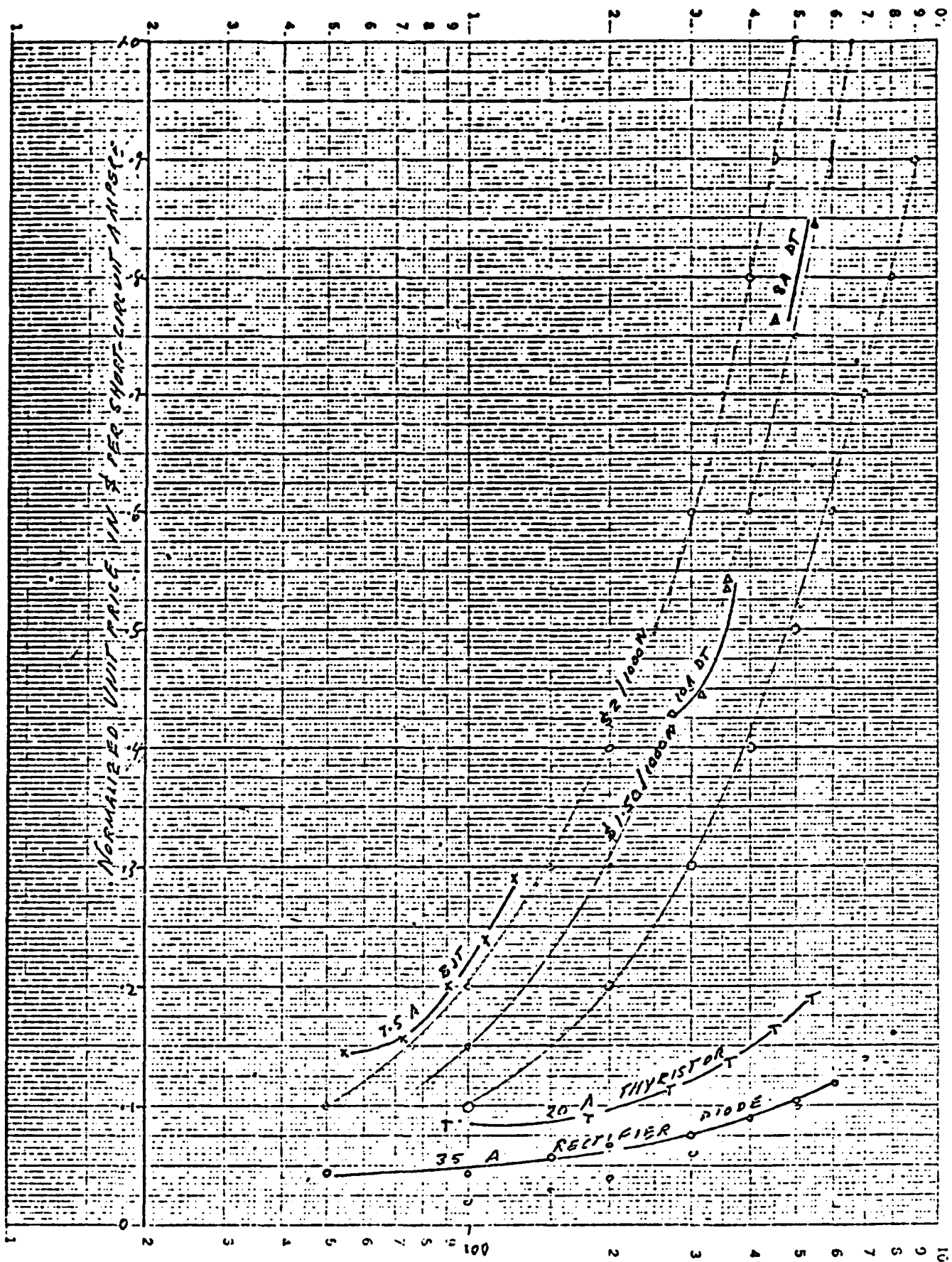

Figure IV-10 Comparison of Darlington Transistor (DT) prices to other control devices

Perhaps the most significant factor is the economy of scale. Using the lowest \$/kW-circuit and comparing the total circuit power switched:

<u>Voltage</u>	<u>kW Switched</u>	<u>\$/kW-Circuit</u>
125	2.5	5.60
250	45	6.00
600	120	5.33

We can see that for the same cost in terms of \$/kW-circuit we can obtain much greater modular flexibility with the 125 volt unit. This rating would not be acceptable for a nominal 120 volt system (180 V_{OC}) except through the use of tapped arrays. However, with an array tapped at 0.3 V_{OC} such a relay would operate in the shunt mode at 1/2 its voltage rating. The 10A current rating also modularizes well with the 8 amp proportional control semiconductors.

A rough comparison of the 125 volt relay-vs-transistors used on a tapped array is

relay (including dust cover)	\$15.00
2 transistors, mounting hardware heat sink and resistors	\$ 7.00

for a differential of \$8.00 for 2.2 kW favoring the transistors. This differential will be further narrowed by assembly costs which favor the relay, or by deleting the dust cover (\$5.25). In short, the relay without dust cover is probably slightly cheaper than the transistor and with dust cover slightly more expensive.

When snubbers of the Hughes China Lake (EPUP) type are used the comparative cost shifts substantially in favor of relays.

The mid-1981 price (100-249 level) in a DPDT PRD11DY0-24AG D&B Power relay was \$6.68. This relay is rated 30 ARMS at 240 VAC, and 20 ARMS at 277 VAC. The snubber permits these predominately AC motor starting, incandescent lamp load relays to operate at a substantial fraction of the AC rating. Without supplemental magnetic blowout cause the use of ferrite PM and with the Hughes circuit, this relay repetitively switched 20A DC on each contact without incident or observable erosion. Its dielectric breakdown for DC should exceed the equivalent AC levels. In the series OFF-ON configuration, the relay will control a minimum of 8.0 kW of peak DC power. With the snubber network, and a blowout magnet (thrown in for good measure), the relay package, including capacitor, diode and resistor, dust cover, is estimated to be less than \$21.00 at current prices. The dollar cost per kW now becomes \$2.60 per kW; which compares favorably with the 20 ampere 200 VDC transistor complement, which prices out at about 5X greater.

A-7. Parametric Cost Model of Heat Ejection Devices

or unattended power installations where the cost of generated power is high, it is assumed that heat ejection will be accomplished by radiation and free convection. This approach has much to recommend it beyond the saving in power. In an unattended installation a fan failure would stop the forced air cooling and limit the ejection to just radiation and free convection. This would likely precipitate a sequence of failures as temperature rose in the control. Design at the outset for only radiation and free convection assures a natural cooling of system which is both simple and robust. This portion of the analysis is directed more to the solid state regulators using Darlington's. The OFF-ON Series regulators, including the Multistate have only one power semiconductor per 1 PU; this is the blocking diode. It produces 8-10 watts thermal at peak power, considerably less than the Darlington switches.

It is worth examining the capabilities of natural cooling using just the outer surface of the control housing. Generally the front door will be ineffective as will also the top. Assuming the two sides and rear to be effectively an area of roughly 1 square meter would be typical. Thus:

Radiation:

For stacked fins with emissivity 0.9 and at temperature T 200°C

$$h_r = 0.228 \times 10^{-6} () (1-F) \frac{T_s + T_a}{2} + 273^3 \frac{\text{watts}}{\text{m}^2 \text{ } ^\circ\text{C}}$$

- = surface emissivity
- F = shielding factor of multiple fins (F = 0 for one fin)
- T_s = fin surface temp °C
- T_a = ambient temp °C

Assume a rectangular 1 m surface of 1/8" aluminum anodized and blacked

- = 0.95
- T_a = 50°C
- T_s = 70°C

h_r above = 8 W per m² °C or 160 W for T = 20°C

A-8. Free Convection:

For vertical fins at sea level and T 800°C

$$h_c = 3.42 \frac{T}{39.4}^{0.25} \text{ w/m}^2 \text{ } ^\circ\text{C}$$

T = difference in temp
between fin and ambient
in $^\circ\text{C}$

$$h_c \text{ above} = 2.88 \text{ w/m}^2 \text{ } ^\circ\text{C}$$

= length of fin in meters

or 58 W for T = 20 $^\circ\text{C}$

Exposing 2 surfaces gives 116 W for a total heat rejection of 276 W for T = 20 $^\circ\text{C}$.

Thus if we use only the surface area of the control housing as a heat ejection means, we are forced to rather large and expensive housings if ejected heat exceeds 150-200 watts. For a series pass transistor the dissipation will be about 7% of system rating. Thus, we would be limited to system capabilities of 2-3 kW using the housing alone. This limitation is unacceptable and so we must consider preformed heat sinks. In several of the electromechanical switching configurations, the branch blocking diode is the only heat generating semiconductor of consequence. Since specific dissipation is low, about 10 watts per kW of peak power, more rudimentary heat sinks, such as the 3/16" aluminum rear panel for the PSMs should suffice.

Heat sinks are available from several manufacturers as either aluminum extrusions or (for low power) as formed aluminum parts. Designs are very similar among manufacturers. In the tabulation below prices of Wakefield Engineering have been used.

Type	Price \$	Watts for C = 30/40/50 $^\circ\text{C}$	\$/watt	
			30 $^\circ\text{C}$	40 $^\circ\text{C}$
Formed to -3	0.48	4/6/7.6	.12	.08
Light Extrusion	1.51	7.5/12/16	.20	.125
1" x 4" Extrusion	2.37	12/17.5/26	.197	.135
2-1/2" x 5" Extrusion	4.26	32/45/60	.135	.095

Despite the wide range of size and type the cost is roughly \$0.15/watt for 30 $^\circ\text{C}$ rise to \$0.12/watt for 40 $^\circ\text{C}$ rise. It is worth noting that a low voltage (120V, 8A) transistor with mounting hardware costs about \$1.50. This unit can dissipate about 40 watts with junction temperature of 120 $^\circ\text{C}$ and 25-30 $^\circ\text{C}$ rise above 50 $^\circ\text{C}$ ambient. The heat sink to accomplish this costs \$4.26 or almost 3 times as much. Only when transistor voltage rating reaches 300 volts does the cost of the semiconductor approach that of the heat sink.

8. Cost Models of Control Circuits

We must examine the design requirements of each circuit type to determine a required rating for the switching device. From these ratings and the component cost models a control cost model can be constructed.

A-9. Series Regulator, Proportional Control

This configuration requires a proportional control. The simple differential current control described in Section ____ would be adequate. There is considerable dissipation in Q_1 accordingly the heat sinks become large and are a significant cost item. Thus it is worth examining the dissipation requirement of Q_1 .

The dissipation for the series pass transistor, P_d , will be:

$$P_d(t) = (V_a - V_f) I$$

Fortunately both V_a and V_f have negative temperature coefficients. Further, the worst case (from the standpoint of V_a) occurs with the lowest ambient temperature. We are justified in taking a mid-range temperature value.

$$P_d(t) \quad t=\text{mid} \quad 34 \cdot I_{\text{load}}$$

If we assume that for brief periods we depart from this steady state, we can estimate the worst case to be:

$$P_d \quad \text{worst case (I)} \quad \frac{V_{oc} - V_f}{2} \frac{I_{no}}{2}$$

$$(V_{oc} - V_f) \frac{I_{no}}{4}$$

or in terms of I_{sc}

$$= (V_{oc} - V_f) \frac{I_{sc}}{4.3}$$

This is also 7.1% of peak array output.

Accordingly the device specifications are:

Major Components

Q_1 - pass transistor

$$P_d = 7.1\% I_{no} \times V_{no}$$

$$V_{oc} \text{ at } I_c = 0$$

$$I_{sc} \text{ at } V_{cesat}$$

HS - 30°C rise over T_a for 7.1% $I_{no} \times V_{no}$

D_1 - coupling diode V_{oc} , I_{sc}

PC - proportional control from I_{batt} , and I_{array} (two switchboard shunts, 1-opamp, 1 dual power supply, two potentiometers, six resistors)

Cost Example (3 kW system $I_{sc} = 23A$, $V_{oc} = 180V$)

$$I_{no} = 21.4A, V_{no} = 140V)$$

X sockets	.84
Q ₁ - 4 x IR5060	17.24
HS - 4 x 423A	17.04
D ₁ - 4 x IN1202A	5.28
PC -	<u>37.00</u>
	\$71.40

Model

$$\$ = 37.00 + INT \frac{I_{no} V_{no}}{714} \quad (10.10) \quad \text{for } V_{oc} \quad 180$$

$$\$ = 37.00 + INT \frac{I_{no} V_{no}}{714} \quad (11.46) \quad \text{for } V_{oc} \quad 360$$

A-10. Shunt Regulator (On-Off Type) Relay

This is a very simple configuration. It tends to modularize at 7-8A and V_f 150V, which is reasonable for 120 volt systems. This is based upon a 10A, 150V rating for a single form-X contact.

Major Components

- CR - power contactor V_{no}, I_{sc} (interrupt)
- D₁ - coupling diode V_{oc}, I_{sc}

Cost Example (3 kW system) I_{sc} = 23A, V_{no} = 140V

CR - 3 - P&B KEUP3D15 - 110 DC	21.84
D ₁ - 3 - IN 1202A	<u>3.96</u>
	\$25.80

Model

$$\$ = INT \frac{I_{sc}}{8} \quad 8.6 \quad \text{for } V_{no} \quad 150 \text{ volts}$$

A-11. Shunt Regulator (On-Off Type) Transistor

Like the relay version this is a simple configuration. It also tends to modularize at 8A, but is flexible on voltage up to V_{oc} - 360 volts. At low voltages bipolar transistors are cheaper, for V_{oc} 180 V Darlington transistors are cheaper.

Major Components

Q_1 - transistor V_{oc} , I_{sc}

D_1 - coupling diode V_{oc} , I_{sc}

CR - partial cost of ordinary industrial control relay 2PDT 3A (shared by several Q_1)

R_b, R_1 - 2W carbon resistors

Cost Example (3 kW system) $I_{sc} = 23A$ $V_{oc} = 180V$

D_1 - 3 IN1202A	3.96
Q_1 - 3 x 2N6249 (h_{fe} 15 @ 7A)	11.25
HS - 3 - 689 series	1.44
sockets	.63
R_b and R_1 6 2W carbon	.60
CR - 1 - KUP14A55 - 115D (actually adequate for 60 kW system)	7.28
PS - 1 6Vdc power supply (also adequate to 15 kW system)	<u>10.00</u>
	\$35.22

Model

$$\$ = 17.28 + INT \frac{I_{sc}}{8} \quad (5.96) \quad \text{for } V_{oc} = 180V$$

$$\$ = 17.28 (+) INT \frac{I_{sc}}{8} \quad (8.31) \quad \text{for } V_{oc} = 360V$$

A-12. Series Regulator (OFF-ON type) Relay

This is also a simple configuration. It tends to modularize at 10 to 20 amps and voltages under 150 VDC. Modularization at higher voltages and current, typically 250 VDC @ 30 amps appears to present no special problems if the appropriate snubbers are used.

Major Components

- power contactor V_{oc} , I_{sc}

D_1 - coupling diode V_{oc} , I_{sc}

In most cases the maximum operating stress on the contactor and the diode only will be $V_{oc} - V_{batt}$.

Cost Example (5 kW system)

$$I_{sc} = 30A$$

$$V_{no} = 175 \text{ VDC}$$

CR (one), with snubber and dust cover	\$21.00
D_1 (three) IN1202A	<u>3.96</u>
	\$24.96

The parametric model is

$$\$ = \text{INT} \frac{I_{sc}}{30} 8.3 \quad \text{for } V_{no} \quad 175 \text{ V}$$

A-13. Multistate OFF-ON Series Contactor

The multistate series contactor regulator becomes an iteration of a A-12 preceding. The control costs vis-avis power level will however be a function of the desired control precisim.

A-14. Shunt Regulator (On-Off Type) Part of Tri-State Control

This configuration takes advantage of the fact that it is not necessary to short the entire array, but only enough to bring $V_{oc} = V_{float}$. This has no effect on power contactor cost except permitting use above 150 volts. It has a significant effect on semiconductor costs.

Major Components

Q_1 - transistor $0.3V_{oc}, I_{sc}$

D_1 - coupling diode V_{oc}, I_{sc}

CR - as before

R_b, R_1 - as before

W - cost of 1 additional wire, #14 at 0.056 per foot

Cost Example (3 kW system) $I_{sc} = 23A$ $V_{oc} = 180V$

D_1 - 3 x IN1202A	3.96
Q_1 - 3 x 2N3716	4.45
HS - 3 689 series	1.44

X sockets	.63	
R _b and R ₁ 2W carbon	.60	
CR - 1 KUP14A55 - 115D	7.28	
PS - 6 Vdc power supply	10.00	
W - 63 ft. #14 PVC @ .056	<u>3.52</u>	(see 6.3)
	<u>\$31.88</u>	

Model

$$\$ = 17.28 + \text{INT} \frac{I_{sc}}{8} (3.70) + \text{INT} \frac{I_{sc}}{17}^{1.3} \times 0.27 \times 6 \quad (\text{see 6.3})$$

For V_{oc} = 240

$$\$ = 17.28 + \text{INT} \frac{I_{sc}}{8} (4.75) + \text{INT} \frac{I_{sc}}{17}^{1.3} \times 0.27 \times 6$$

For V_{oc} = 360

A-15. Tri-State Control

This configuration is similar to the array. for 7/10 of the array and to for 3/10 of the array.

Major Components

- D₁ - coupling diode V_{oc}, I_{sc}
- Q₁ - (on-off) transistor 0.3V_{oc}, I_{sc}
- HS₁ - essentially 8W/Q₁
- Q₂ - 0.3V_{oc}, I_{sc}, P_d = 2.1% I_{no} x V_{no}
- HS₂ - 30°C rise over T_a for 2.1% I_{no} x V_{no}
- PS - becomes part of PC
- CR - as in
- W - as in
- PC - as in

Cost Example (3 kW system)

$$I_{sc} = 23A, V_{oc} = 180$$

$$I_{no} = 21.4A, V_{no} = 141V$$

$D_1 - 2 \times 1202A$	3.96
$Q_1 - 2 \times 3716$	2.97
$HS_1 - 2 \times 689$.96
$Q_2 - 1 \times 2N6284$	3.00
$HS_2 - 1 \times 423A$	4.26
CR - KUP14A55 - 115D	7.28
W - 63 ft #14 PVC @ .056	3.52
PC =	37.00
sockets, resistors, etc.	<u>1.22</u>
	<u>\$64.17</u>

Model

$$\begin{aligned} \$ = & 44.28 + \text{INT} \frac{I_{no} V_{no}}{2380} (8.82) + \text{INT} \frac{I_{sc}}{11.4} (3.70) \\ & + \text{INT} \frac{I_{sc}}{17} \frac{1.3}{x} \times 0.27 \end{aligned}$$

A-16. Series-Switched Regulator

The design of this charging control is complex (see section 6.4). The component sizes depend upon design assumptions which do not readily permit modeling. However, as an illustration of cost a 3 kW control is designed (section 6.4) and the component costs outlined below.

Major Components (load = 4A at 141 volts)

$Q_1 - V_{oc}, I_{sc}$, Darlington (for control)

HS - approx. $P_d - 2 \times I_{load}$

CR - V_{oc}, I_{sc} (each contact)

L - 15 mH, 4A, $R_{dc} \quad 1$ (ferrite toroid)

C - 1.7 F, V_{oc} , (plastic film only)

X $D_1 - V_{oc}, I_{load}$

V_r - temp compensated voltage reference (at + voltage level (probably
3-Zeners 3-diodes)

Cost Estimate

$Q_1 - 1 - IR5060$	4.31
HS - 1 - type 623	1.51
L - 1 - special (est)	15.00
C - 1 - GE-97F8511FB	6.50
$D_1 - 1 - IN1202A$	1.32
CR - 2 - P & B KEUP	14.04
OA - including socket, $R_1 R_f$	1.50
PS - ± 15 Vdc power supply	20.00
VR - 3 - IN5261	<u>3.39</u>
	<u>\$67.57</u>

APPENDIX B - TEMPERATURE CONTROL OF BATTERIES BY MEANS OF UNDERGROUND STORAGE

A conceptual study was undertaken to determine the feasibility of underground storage of batteries, as a means of maintaining the temperature of the batteries at a level which would prolong the life of the batteries. For this study the soil and weather conditions of Phoenix, Arizona was used.

A nine (9) cell battery package (3 cells per pack) enclosed in a ½" thick thermoplastic box of the following dimensions: 27" wide X 27.5" long X 24" high was evaluated thermally for locations at ground level, two (2) feet below ground and four (4) feet below ground. The maximum thermal dissipation of each cell was 5.7 watts.

The temperature excursions of the batteries over a period of 72 hours for the three (3) conditions studied, both for summer and winter is displayed in Figure 1.

The temperature performance of the batteries for the extremes of summer and winter seasons are summarized below in Table 1.

TABLE 1

<u>Season</u>	<u>Location</u>	<u>Max. Temperature OF</u>	<u>T Cycle OF</u>
Summer	Above ground	104.5	8.5
	2 feet below ground	96.9	4.6
	4 feet below ground	85.7	0.9
Winter	Above ground	60	7.5
	2 feet below ground	65	3.5
	4 feet below ground	64.5	1.0

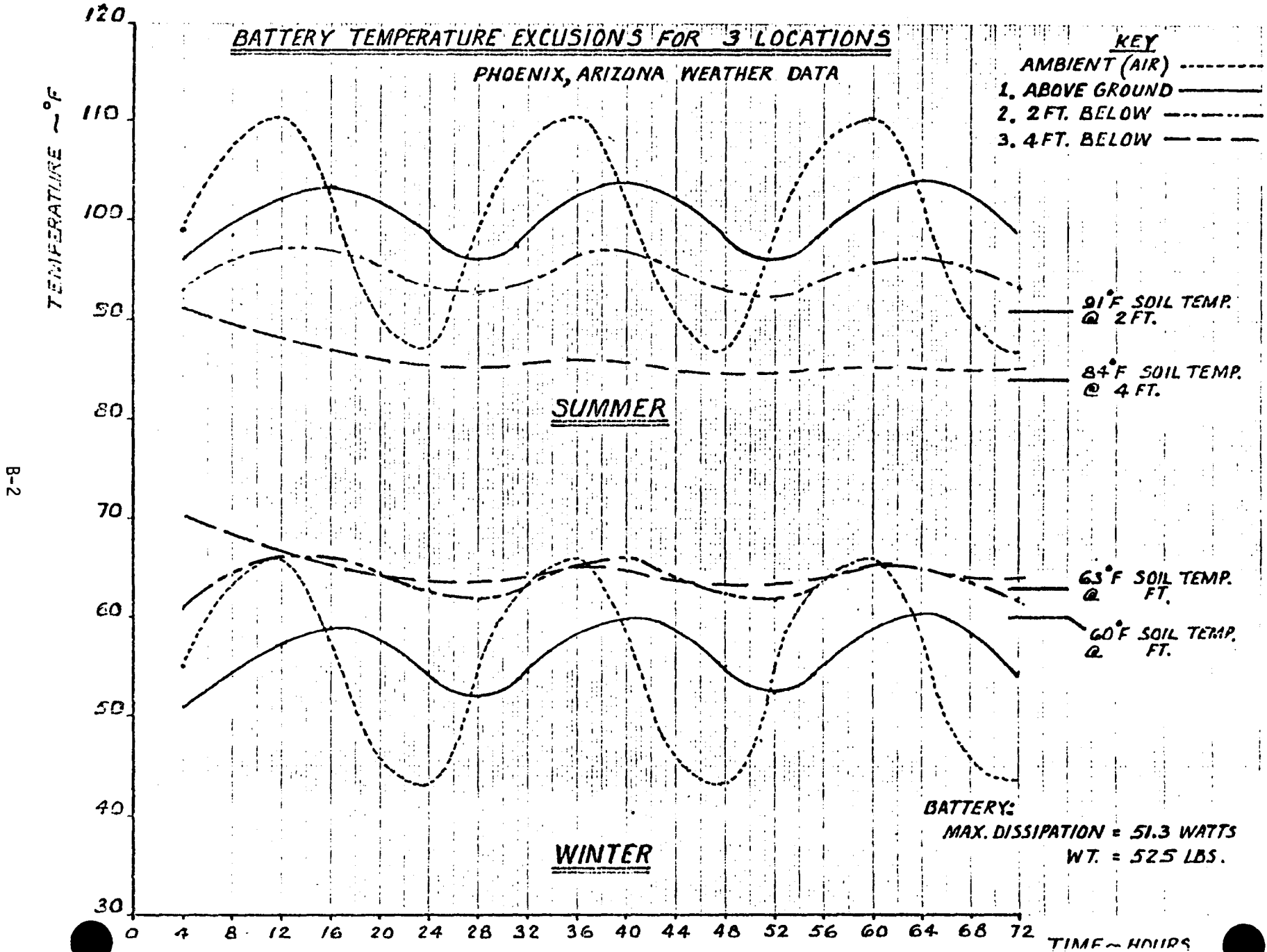

B-2

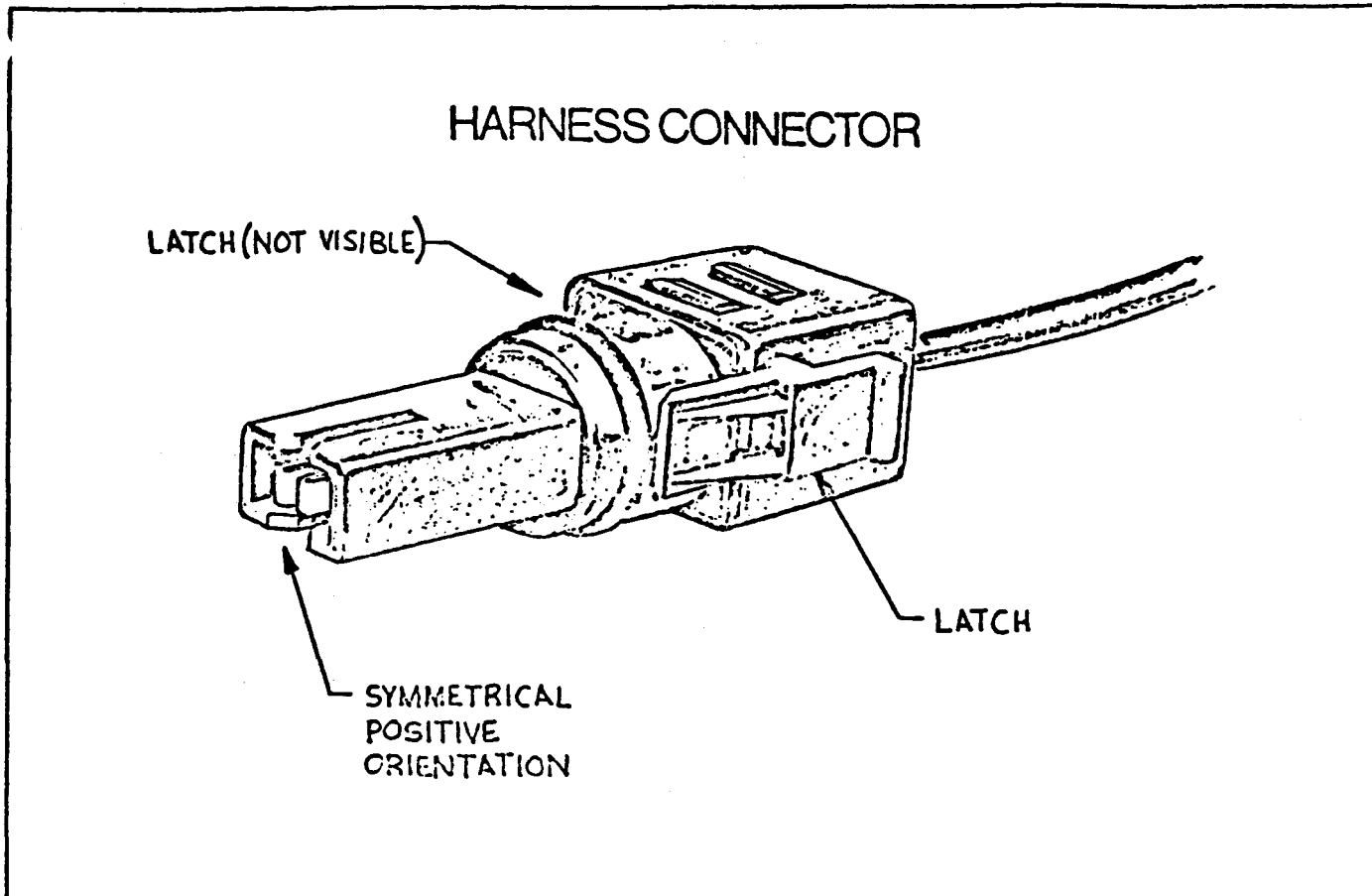

FIGURE - 4

4.1 Harness Connector

Figure-4 depicts the pre-assembled Harness Connector. Quick mating and unmating of the Harness Connector to and from the Bus Bar Housing is accomplished by the integral molded latches.

4.2 To mate the Harness Connector, it is guided into the Bus Bar Housing cavity in a symmetrical, positive orientation until the two connectors bottom out.

4.3 With slight additional pressure applied to the back of the Harness Connector, the 2 latches will snap in place on the Bus Bar Housing latch embossments.

4.4 To unmate, the 2 latches are simultaneously depressed inward by thumb and index finger in the area provided by the latches.

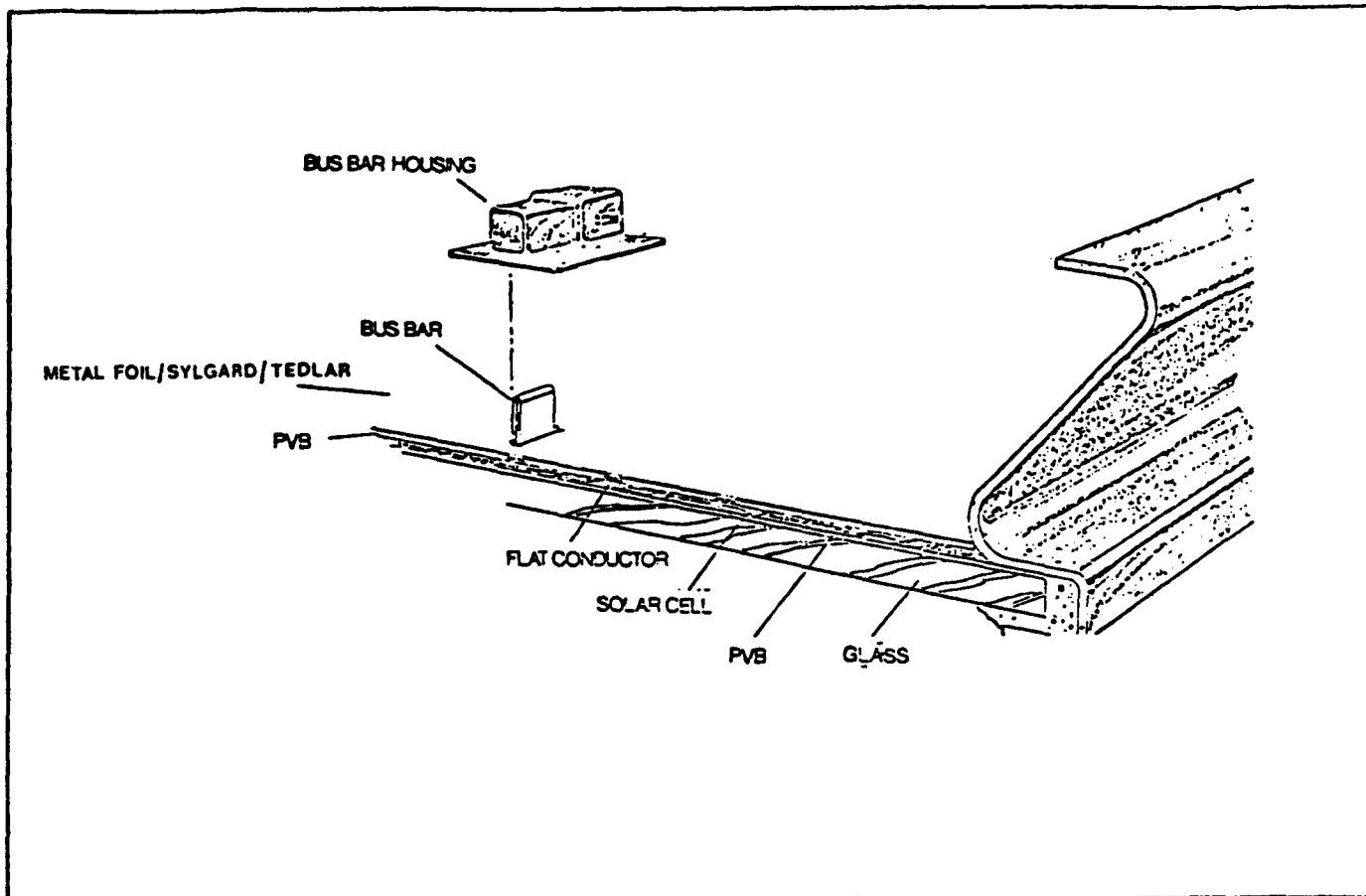

FIGURE-4

3.1 Mounting Bus Bar Housing

On the underside Housing surface, a rectangular slot is located for the Bus Bar tab entry. Position and guide the Housing coated with adhesive in a manner to allow the Bus Bar tab, to enter into the Housings through the rectangular slot.

3.2 The inside top surface of the Housing also has an undercut rectangular slot directly in line with the slot referred to in paragraph 3.1. Ensure that the Bus Bar tab is guided into and seats directly into the internal rectangular undercut.

3.3 In the foregoing steps care should be taken not to wipe any adhesive onto the Bus Bar tabs.

3.4 With the Housing adhesive coated surface in contact with the Solar Module laminate, clamp together the Bus Bar Housing top surface and the underside surface of the Solar Module with a suitable clamping device.

3.5 Wipe off any excess adhesive as a result of the clamping pressure

3.6 Allow at least 30 minutes for the adhesive to cure.

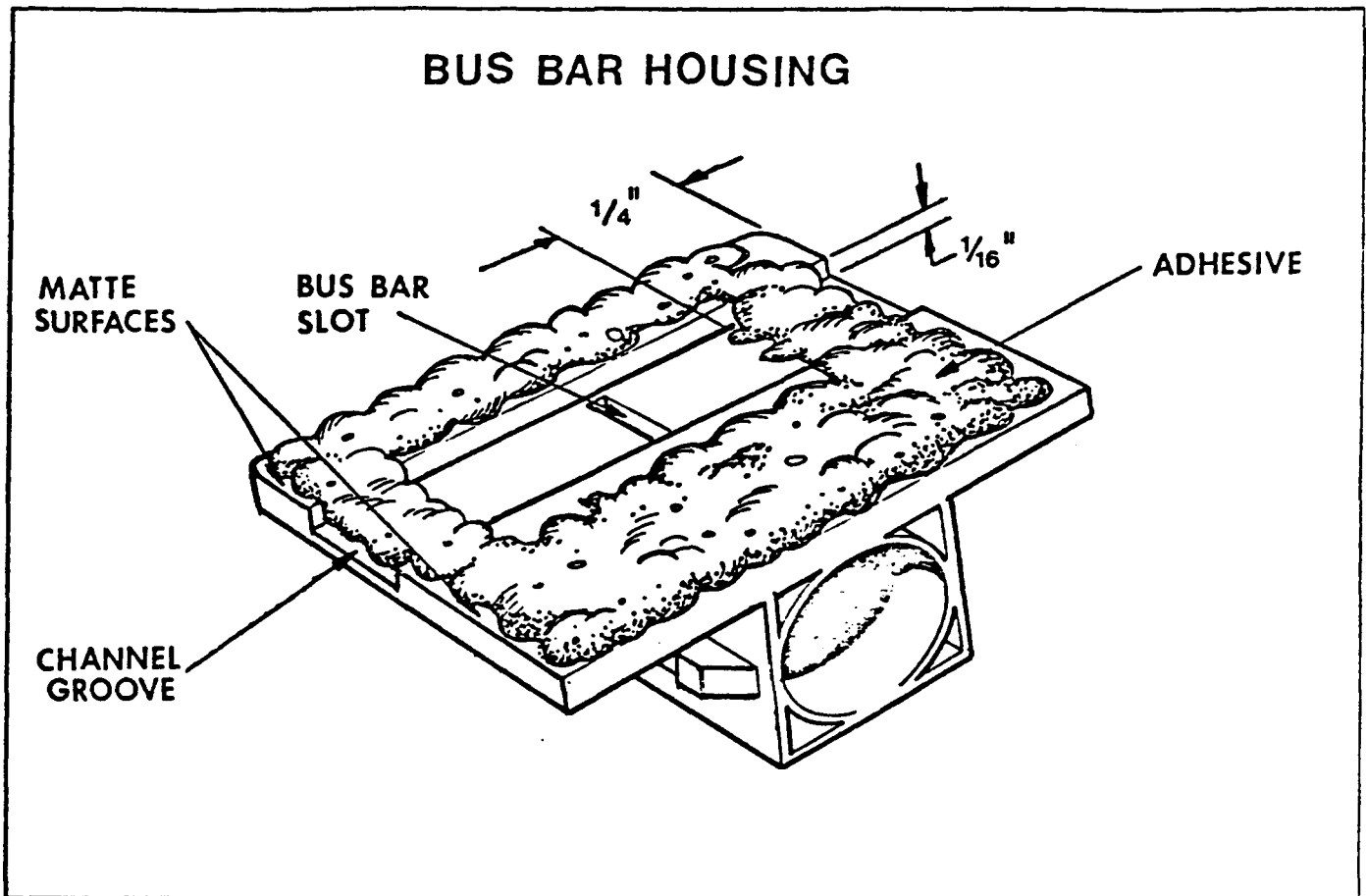

FIGURE-2

2.1 Bus Bar Housing

There are two matt textured surfaces on the underside of the Bus Bar Housing, indicated by arrows in Figure-2. They are separated by a groove. Both of those matt surfaces require adhesive for attachment to the Solar Module.

2.2 Scotch-Weld[†], a 2 part Structural Adhesive #3501 manufactured by 3M Company was found to be suitable in the application tested. Other commercially available epoxy type, Dow-Corning Structural Adhesives may be suitable as well. Use in accordance with manufacturers' instructions.

2.3 Apply adhesive on the underside Bus Bar Housing surface only. Observe that the adhesive coverage on the surfaces is complete and no voids are visible.

2.4 Avoid adhesive in the Bus Bar slot. Except at both ends of slot approx. $\frac{1}{4}$ " from ends of housing where adhesive is needed to complete sealing.

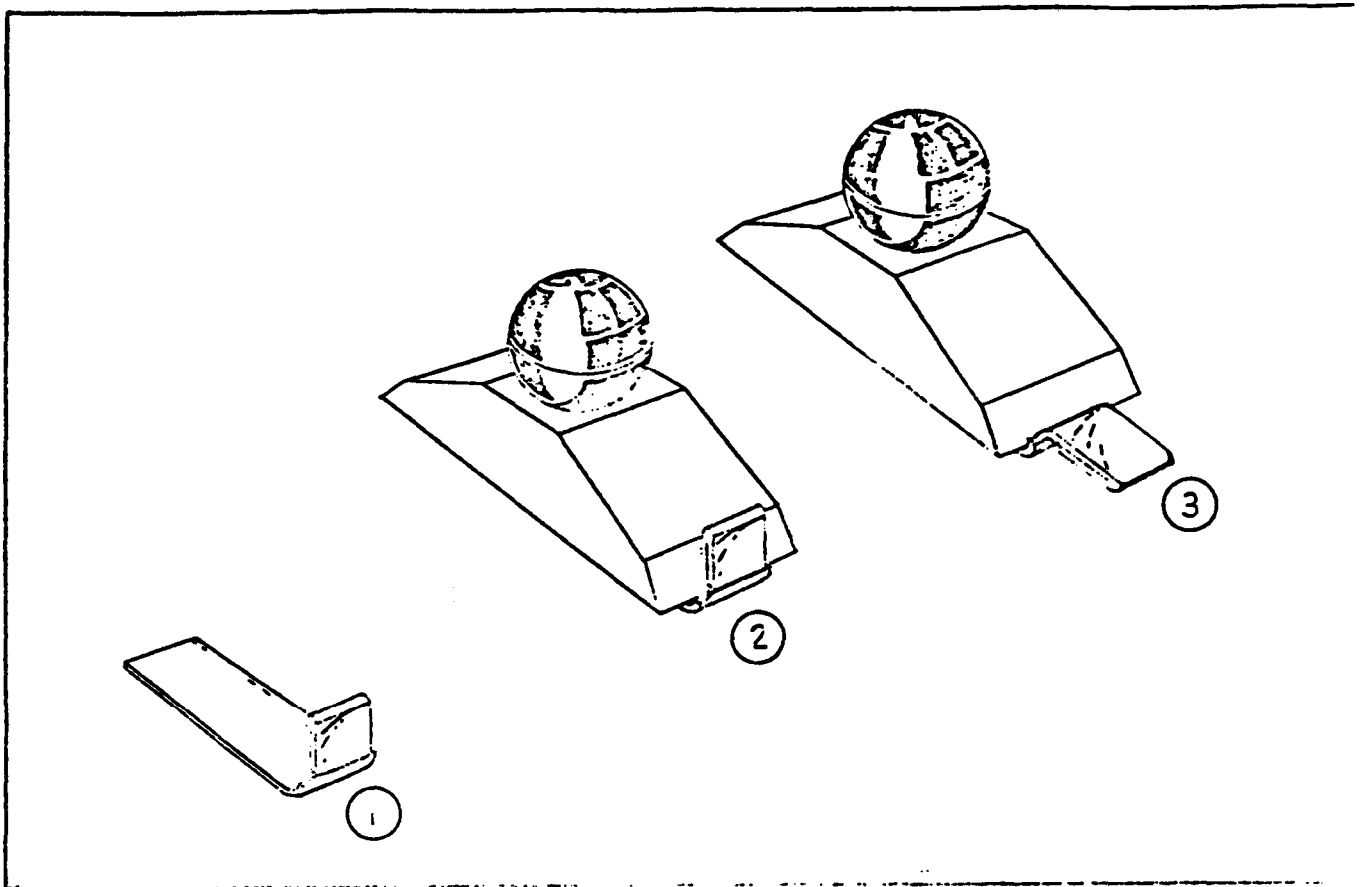

FIGURE-5

5.1 Bus Bar Installation

Depending upon the method used to manufacture the Solar Module, the Bus Bar tab may or may not need to be bent in the horizontal plane.

- 5.2 If the Bus Bar tab requires to be temporarily repositioned to facilitate Module lamination, the following steps are offered as a recommendation only.
- 5.3 With Bus Bar in position as shown by label (1) in Figure-5, guide and place Bending Fixture over the Bus Bar as shown in Figure-5 label (2).
- 5.4 Hold fixture firmly against the flat Bus Bar surface and apply moderate pressure.
- 5.5 Simultaneously with the free hand, bend Bus Bar tab 90° in the outward direction with fingers to position shown in Figure-5 label (3).
- 5.6 When the Solar Module laminating process is complete to the extent which will allow the Bus Bar tab to be returned to its original position, repeat steps 5.3, 5.4 and 5.5 except bend tab up 90 to position labeled (2).

WHAT IS PHOTOVOLTAICS?

Photovoltaic energy conversion is the process of converting sunlight directly into electric energy. As the cost of energy from traditional sources continues to rise, and as the cost of converting sunlight into electricity decreases, photovoltaic systems are becoming an economic reality.

Some photovoltaic applications require continuous energy 24 hours a day. If no utility grid or back-up exists to supply power when there is no sun, then batteries are required. Lead-acid batteries, today's most reliable energy storage devices, have been adapted by C&D to meet the special demands of photovoltaic applications.

TYPICAL PHOTOVOLTAIC CIRCUIT

Typically, photovoltaic systems consist of solar cells assembled in an array to produce a nominal output of six or 12 volts. Arrays are added to the system in series to increase voltage or in parallel to increase current. The array is then connected to the battery through a voltage conditioning circuit which protects the array from battery voltage and protects the battery from over- and under-voltage.

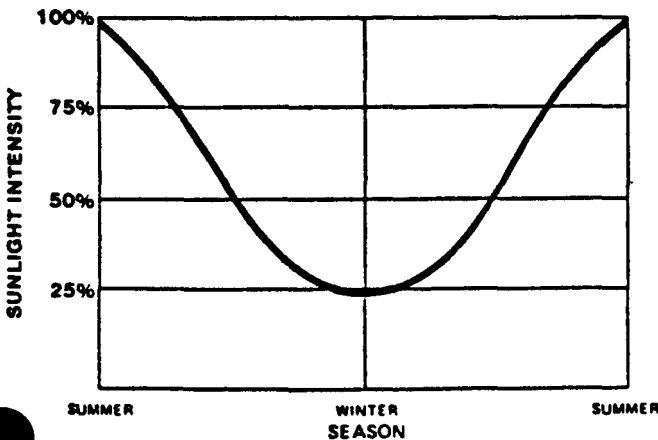
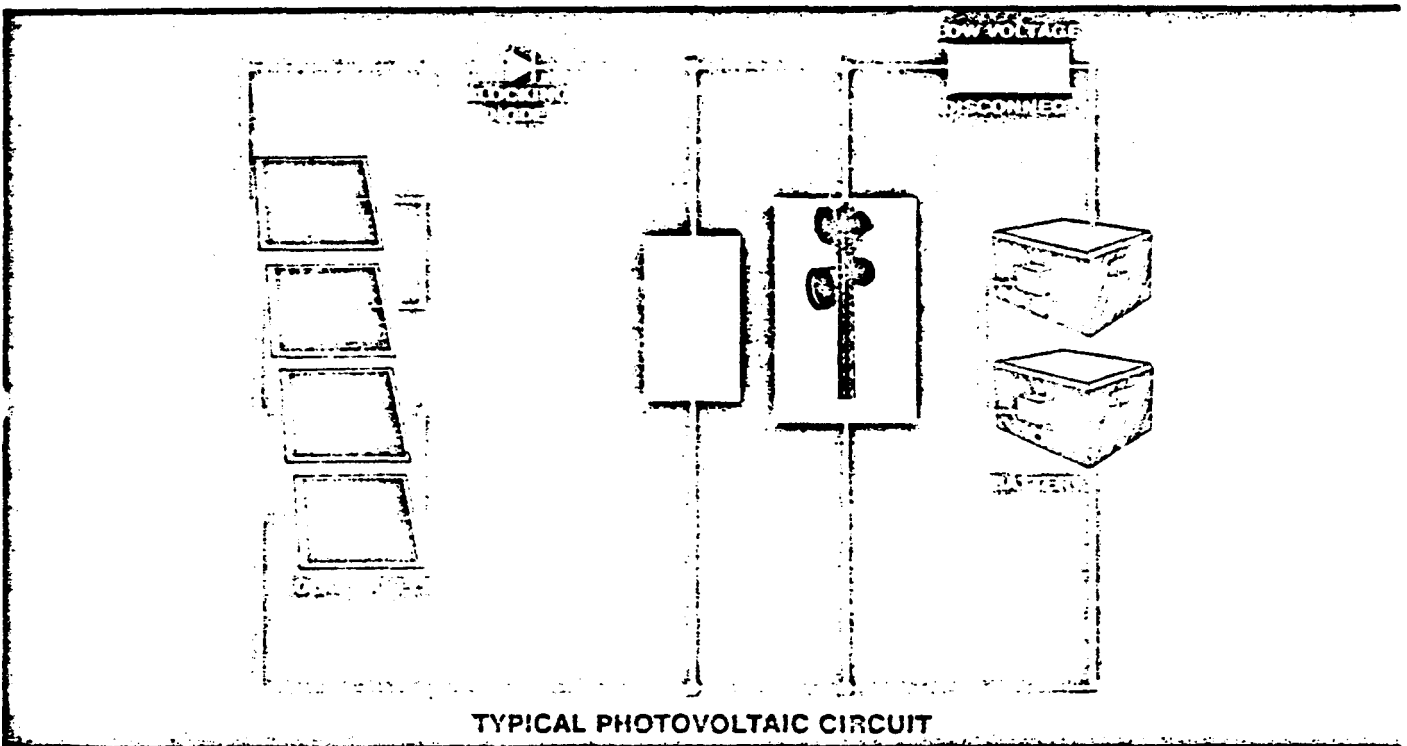

SEASONAL SUNLIGHT VARIATIONS

The battery, connected to the load through a low-voltage sensing circuit, stores energy from the array for use when there is little or no available solar energy — nights and overcast days.

During high solar energy periods, the array supplies the routine needs of the load and maintains the batteries in a charged condition.

The output of a photovoltaic array is determined by the intensity of the sun and is rated in peak watts — the output in watts at peak solar intensity.

The solar intensity will vary depending on the time of year; in the northern hemisphere it's less intense in the wintertime than in the summer.

TYPES OF PHOTOVOLTAIC APPLICATIONS

Batteries for photovoltaic systems fall into one of two application types. These are based on the percent of the batteries' capacity that may be used in a given period of time: the applications are referred to as either "shallow cycle" or "deep cycle".

SHALLOW CYCLE

Shallow cycle applications are usually located in areas where there is no utility or emergency back-up power supply. Therefore, the battery must have sufficient capacity to provide energy for the maximum number of sunless days.

Shallow cycle applications require a discharge that is only a small portion (up to 20%) of a battery's capacity.

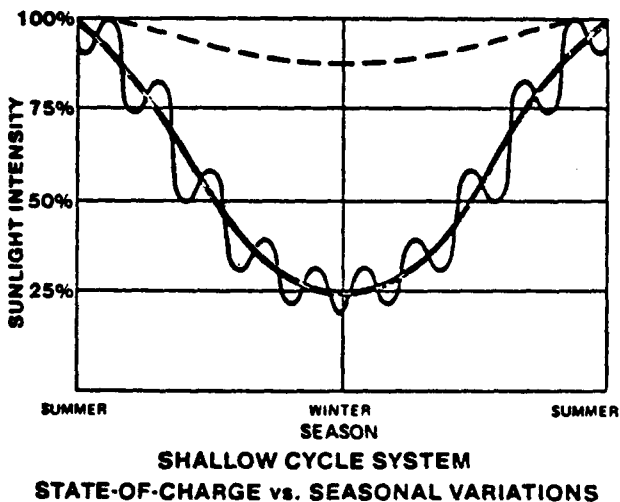

Superimposing a daily 10-20% discharge on the annual sunlight variation curve results in the state-of-charge curve marked in red.

In addition to changes in annual sunlight intensity, the number of sunless days that can occur at a specific latitude must also be considered. While only 10% may be taken out during a specific period, this limited discharge may be continued for five to 20 days before sufficient sunlight is available to return the battery to a higher state of charge.

By oversizing the array, a higher state-of-charge can be maintained on the battery, as shown by the dashed line in the above curve. However, this practice does not allow maximum utilization of batteries built by C&D.

Therefore, when sizing a battery both the annual sunlight conditions and the worst case sunless days for that location must be considered.

DEEP CYCLE

Deep cycle applications are those which utilize up to 80% of the battery capacity every one to three days. These types of application usually require emergency back-up (i.e. utility grid or diesel generator) to recharge the battery in case the sun doesn't shine for several days.

Since these batteries are discharged deeply (cycled), their physical make-up and construction is completely different from a shallow cycle battery, as described later.

Very short battery life will result if a shallow discharge type battery is applied to a deep discharge application.

APPLICATION EXAMPLES

Shallow cycle:

- Microwave repeaters
- Railroad crossing gates
- Communication towers
- Navigational aids
- Cathodic protection

Rule of thumb: A shallow cycle battery can be discharged up to 20% of its rated capacity on a daily basis — and occasionally be discharged to 80% of its rating.

Deep cycle:

- Village electrification
- Residential (home owner)
- Public park visitor center
- Rural electrification

Rule of thumb: A deep cycle battery can be discharged up to 80% of its rated capacity on a daily basis.

BATTERY CONSTRUCTION

Photovoltaic applications can impose harsh conditions on a battery. They must operate over a wide range of ambient temperatures, receive little or no maintenance and, worst of all, must perform most of their life in a partial state of discharge.

C&D is aware of these special demands and

offers our customers a battery especially designed to meet the challenge.

Only C&D Batteries offers an exclusive line of lead-calcium alloy batteries to meet the rugged requirements of all photovoltaic applications. And we do it with a proven history of performance. C&D was the first battery manufacturer to utilize battery grids made from lead-calcium alloy instead of the antimonial alloy used in conventional batteries.

C&D calcium batteries offer four distinct advantages over antimony batteries:

ADVANTAGES OF LEAD-CALCIUM BATTERIES

FEATURE

BENEFIT

- | | |
|---|--|
| <p>A. Significant reduction in open circuit stand losses. See chart below.</p> | <ol style="list-style-type: none"> 1. Use smaller array. 2. More battery energy goes to the load. |
| <p>B. Less water consumed by battery on charge.</p> | <ol style="list-style-type: none"> 1. Longer intervals between watering which means less maintenance. |
| <p>C. No transfer of antimony to negative.</p> | <ol style="list-style-type: none"> 1. Reduced charge current throughout life of the battery which improves recharge efficiency. 2. Possibly a smaller array can be used. 3. More power to the load as the battery ages. |
| <p>D. When operated at proper float voltage calcium battery never needs equalization charge.</p> | <ol style="list-style-type: none"> 1. Longer battery life. 2. Less maintenance. |

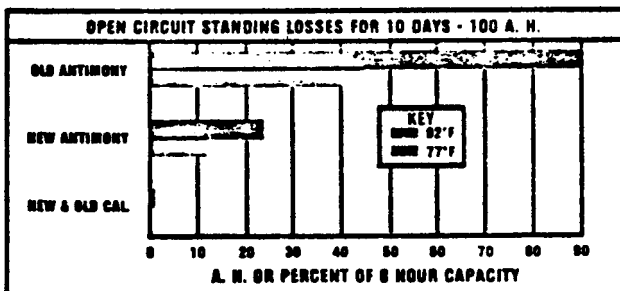

C&D batteries for photovoltaic applications are designed with extra electrolyte volume. This permits operating the battery to greater depths of discharge without concern for freezing, thus permitting greater power utilization over a wider ambient temperature range.

This abundance of electrolyte also increases cell capacity and reduces the frequency of watering requirements.

The following graphs show the effects of temperature on battery capacity and on the freezing point of electrolyte.

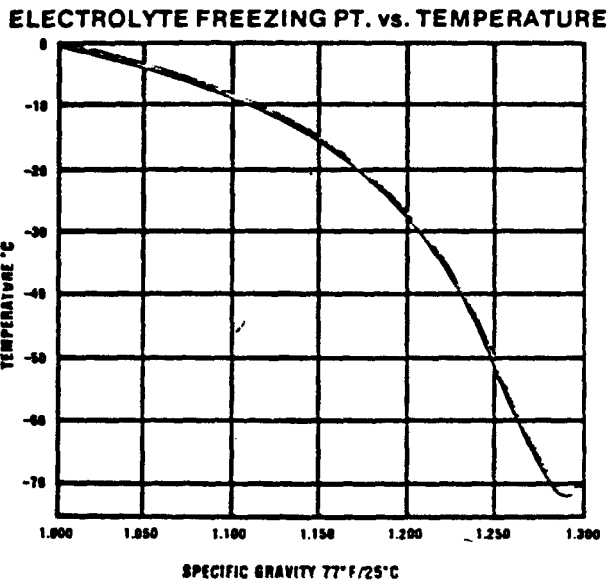
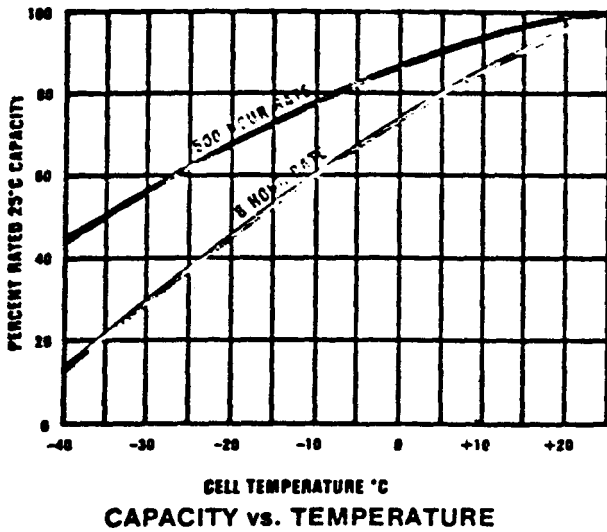

RETENTION SYSTEM

All C&D batteries for photovoltaic applications utilize a mechanical retention system that holds the active material in place in the grids. Active material is what makes the battery work — the longer it is kept in contact with the grid the longer the battery will last.

Slyver-Clad[®], a parallel glass filament mat, is wrapped around the positive plates to keep active material in place. A Polyweb[®] expansion mat is added for the shallow cycle batteries while deep cycle batteries have two glass expansion mats and a Koroseal[®] retainer.

C&D Batteries goes one step further to present a product that will lower the cost of system ownership. When buying a C&D battery for photovoltaic applications, you purchase a product that is designed specifically for the purpose and one that will generate trouble-free power for years to come.

C&D Shallow Cycle Battery (Types D's and K's)

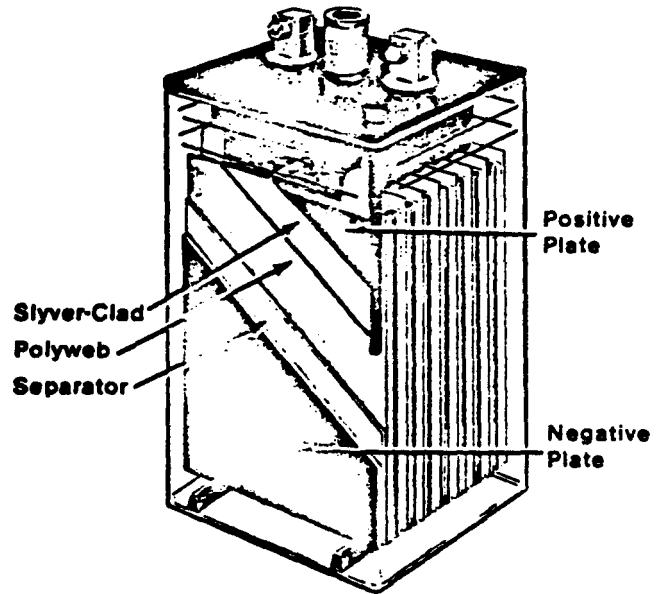

C&D Deep Cycle Battery (Type QP)

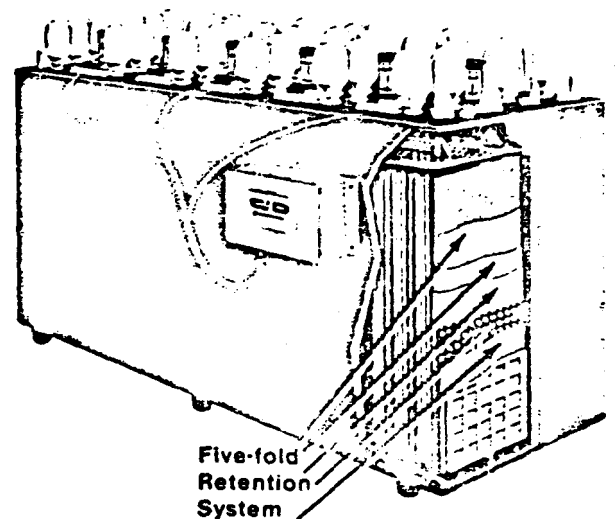

STANDARD OPTIONS (PRE-ENGINEERED)

C&D has developed a number of standard options that provide special benefits for various photovoltaic applications. These are listed as follows:

OPTION 1 - Battery Enclosure

for
Shallow
Cycle
Batteries

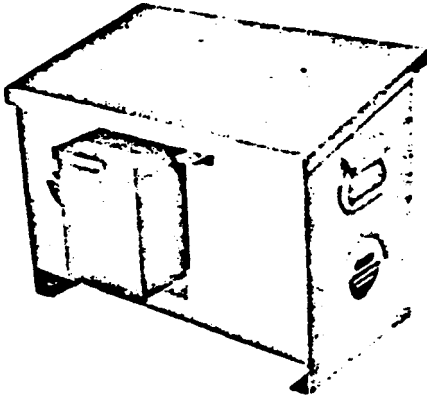

- Hinged, lockable cover
- Rust resistant epoxy powdered steel tray
- Drip-proof construction
- Feet and handles for ease of handling
- Battery installed and prewired to terminal box
- Burned on positive cable connection increases connection reliability
- Batteries available in 12-volt configurations
- Insulated enclosure
- Space available for gas recombiner option

The only thing required of the customer is to set the enclosure on a prepared site (level concrete or gravel), install the two leads from the photovoltaic system and the C&D battery is ready to function. For system voltages with greater than 12 volts, connect battery in series (i.e. two enclosures in series = 24 volts).

OPTION 2 - Gas Recombiners

for
Deep
and
Shallow
Cycle
Batteries

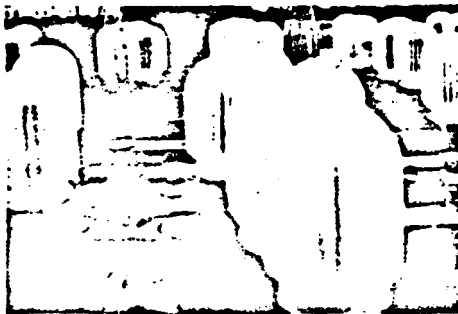

Catalytic action recombines the hydrogen and oxygen gases, generated during end of charge, back into water, thus significantly reducing the frequency of watering of the cell.

One recombiner per cell is required and can only be used with lead-calcium batteries.

OPTION 3 - Interconnects

for
Deep
Cycle
Batteries

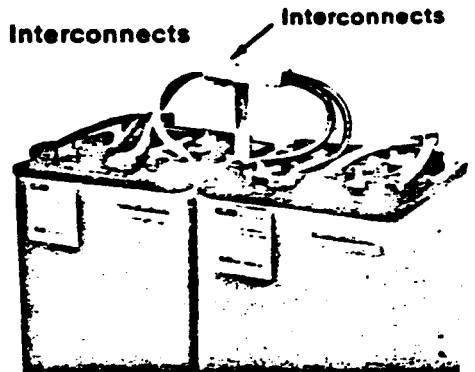

This feature is recommended for applications where a large number of cells are used and provides the following benefits:

- Fast and easy installation. No torque wrench is required to connect intercell parts.
- Reduced maintenance because of:
 - Burned on post connectors reduce corrosion points.
 - No periodic retorquing of intercell connectors is required.
- Snap lock closure for quick positive connection

OPTION 4 - Electrolyte Circulation Pump

for
Deep
Cycle
Batteries

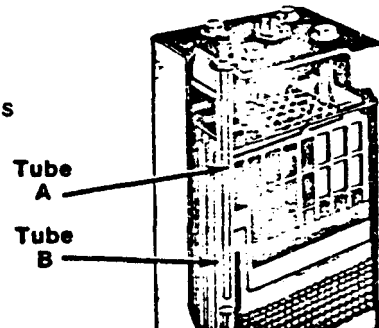

To properly mix the electrolyte during charge it is recommended that deep discharge batteries have an end-of-charge voltage at 2.6 to 2.65 volts per cell. If the photovoltaic panel cannot generate this recommended charging voltage, then electrolyte circulating pumps are recommended for installation into each battery cell. The pumping action is created by the bubble of air emitted from tube A and traveling up the inside of tube B. This option prevents electrolyte stratification which is one of the major causes of reduced battery life.

Not included with this option is the external air power supply or the interconnecting tubing.

SPECIFICATIONS — TYPE DCP & KCP BATTERIES SHALLOW DISCHARGE BATTERIES

**Normal and Cold Climate Application Data
Average Annual Temperature less than 90°F (32°C)**

Cell Type	AH Capacity @ 77°F (25°C)					Overall Dimensions						Weight	
	to 1.75 VPC	to 1.90 VPC				Length		Width		Height			
	8 Hr.	3 Day	5 Day	10 Day	20 Day	In.	mm.	In.	mm.	In.	mm.	lbs.	kgs.
		72 Hr.	120 Hr.	240 Hr.	480 Hr.								
3DCPSA- 3	31	44	46	48	49	5.28	134	7.38	187	10.31	262	27.7	12.6
3DCPSA- 5	62	72	73	74	75	5.28	134	7.38	187	10.31	262	33.6	15.2
3DCPSA- 7	94	133	139	145	150	9.47	241	7.38	187	10.31	262	54.3	24.6
DCPSA-11	156	222	230	240	249	6.38	162	7.38	187	10.75	273	37.0	16.8
DCPSA-13	188	267	277	290	300	6.38	162	7.38	187	10.75	273	39.0	17.7
DCPSA-15	219	295	300	306	310	6.38	162	7.38	187	10.75	273	41.0	18.6
3KCPSA- 5	225	315	324	333	340	8.53	217	10.44	265	18.25	464	131.0	59.4
KCPSA- 7	337	384	389	394	400	3.62	92	10.44	265	18.25	464	58.0	26.3
KCPSA- 9	450.	506	513	520	524	4.62	117	10.44	265	18.25	464	79.0	35.8
KCPSA-11	562	618	628	638	644	5.59	142	10.44	265	18.25	464	96.0	43.5
KCPSA-13	675	743	755	766	773	6.59	167	10.44	265	18.25	464	113.0	51.3
KCPSA-15	787	1011	1031	1047	1060	8.53	217	10.44	265	18.25	464	139.0	63.0

Recommended end of charge voltage — 2.50 to 2.55 volts per cell @ 77°F (25°C)

Specific gravity @ 77°F (25°C) — full charge — 1.300

Recommended start of charge current — up to 20 amperes per 100 AH rated 8.Hr. capacity

SPECIFICATIONS — TYPE QP BATTERIES

DEEP DAILY DISCHARGE BATTERIES

Cell Type	AH Capacity @ 77°F (25°C)					Overall Dimensions						Weight Including Tray	
	to 1.70 VPC		to 1.75 VPC			Length		Width		Height		lbs.	kgs.
	6 Hr.	8 Hr.	12 Hr.	16 Hr.	24 Hr.	In.	mm.	In.	mm.	In.	mm.		
QP75- 5	150	154	165	170	176	1.89	48	6.19	157	22.75	578	33	15
QP75- 7	225	231	249	255	264	2.64	67	6.19	157	22.75	578	46	21
QP75- 9	300	308	330	340	352	3.39	86	6.19	157	22.75	578	58	26
QP75-11	375	385	412	425	440	4.14	105	6.19	157	22.75	578	71	32
QP75-13	450	462	495	510	528	4.89	124	6.19	157	22.75	578	84	38
QP75-15	525	539	577	595	616	5.68	144	6.25	159	22.75	578	96	43
QP75-17	600	616	660	680	704	6.43	163	6.25	159	22.75	578	109	49
QP75-19	675	693	742	765	792	7.18	182	6.25	159	22.75	578	122	55
QP75-21	750	770	825	850	880	7.93	201	6.25	159	22.75	578	134	61
QP75-23	825	847	907	935	968	8.68	220	6.25	159	22.75	578	147	67
QP75-25	900	924	990	1020	1056	9.47	240	6.25	159	22.75	578	160	73
QP110-19	990	1012	1089	1134	1197	7.18	182	6.25	159	29.88	759	178	81
QP110-21	1100	1125	1210	1260	1330	7.93	201	6.25	159	29.88	759	196	89
QP110-23	1210	1237	1331	1386	1463	8.68	220	6.25	159	29.88	759	215	97
QP110-25	1320	1350	1452	1512	1596	9.47	240	6.25	159	29.88	759	233	106

Recommended end of charge voltage — 2.60 to 2.65 volts per cell @ 77°F (25°C)

Specific gravity @ 77°F (25°C) — full charge — 1.290

Recommended start of charge current — up to 20 to 25 amperes per 100 AH rated 6 Hr. capacity

* Cells are mounted in multi-cell trays. In order to determine trayed battery weight and dimensions do the following:

Trayed Battery Weight: Multiply number of cells in a tray by the cell weight.

Example:

6 cell QP75-11

Weight Calculation = 6 cells X 32KG = 192KG

Trayed Battery Dimensions: Multiply cell dimensions by tray configuration.

Example:

2x3 Tray Configuration for QP75-23 (6 cell tray)

Width = 2 X 159MM = 318MM

Length = 3 X 220MM = 660MM

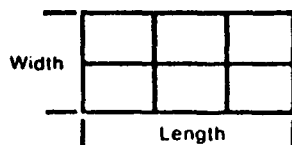



Sales and Service in Principal Cities from Coast to Coast

PLANTS

CALIFORNIA — SANTA ROSA
GEORGIA — CONYERS
INDIANA — ATTICA
INDIANA — BROOKSTON
NEW YORK — HUGUENOT
PENNSYLVANIA — BECHTELSVILLE
PENNSYLVANIA — CONSHOHOCKEN
PENNSYLVANIA — EAST GREENVILLE
PENNSYLVANIA — LEOLA
PENNSYLVANIA — PENNSBURG
TENNESSEE — DUNLAP
TENNESSEE — PIKEVILLE
BRAZIL — SAN PAULO
CANADA — PERTH, ONTARIO



C&D Batteries is the largest manufacturer of industrial batteries in North America. We have 14 plants throughout the United States and Canada and over 75 sales and service facilities. These facilities are staffed with factory-trained, highly competent personnel who can size the proper battery for your needs - and then make sure it continues to serve you properly.

Achieving this prominence in American industry did not occur overnight - and it certainly wasn't by accident. Starting back in the early '40's, already in the battery business for their fourth decade, C&D concentrated their efforts on industrial batteries with the same traditions of quality, dependability and development. These traditions have become as synonymous within industry as our C&D logo.

The list of C&D firsts in new product development is long and impressive. Briefly the list includes pioneering lead-calcium as a grid alloy in many new fields, adapting high-impact plastics for battery jars, improvement of a glass filament material called 'Slyver-Clad' as a plate retainer wrapping, and of course the ferroresonant charger. Now these are all accepted as industry standards.



APPENDIX E - PRODUCT SPECIFICATION: SOLAR CELL MODULE

 HUGHES AIRCRAFT COMPANY	TITLE PRODUCT SPECIFICATION SOLAR CELL MODULE MODULAR STAND-ALONE SYSTEM	NUMBER SEP 11396	REV C
		CODE IDENT NO. 82577	TOTAL PAGES 12

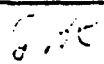
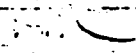
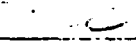
REVISIONS

EFF	AUTHORITY	LTR	DESCRIPTION	DATE	APPROVED
		A	Fig 1.0, is: 51 ₋₁₃ ⁺⁰⁰ (2.0 _{-0.5} ^{+0.5}) was: 51 ₋₁₃ ⁺⁰⁰ (2.0 _{-0.5} ^{+0.0})	5/26/82	
	DCN #419754	B	Revised per DCN #419754	6-17-82	
	DCN #390198	C	Revised per DCN #390198	6-22-82	

APPROVALS

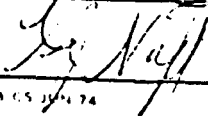
	DATE	DATE
	5/14/82	
	5/21/82	
	5/24/82	

114111 CS 20-4 74

PRODUCT SPECIFICATION

SOLAR CELL MODULE

MODULAR STAND-ALONE SYSTEM

1.0 Scope

This specification defines the requirements for the design and construction of photovoltaic solar cell modules (herein referred to as the module) to be used for terrestrial applications.

1.1 Design Requirements

The module shall be designed to meet all requirements specified herein. Designated tests shall be successfully completed demonstrating the ability of the module to meet all performance requirements of this specification.

1.2 Deviations and Changes

Deviations from or changes to this specification shall not be allowed without written authorization from Hughes.

2.0 Applicable Documents

2.1 Government Documents

The following documents, of the exact issue shown or of the current issue when no date is shown, form a part of this specification to the extent specified herein. In the event of conflict between the documents referenced herein and the contents of this specification, the detail contents of this specification shall be considered as binding.

JPL 5101-83, Block IV Solar Cell Module Design
and Test Specification for Residential Applications
(November 1, 1978).

JPL #5101-138, 1982 Technical Readiness Module, Design and
Test Specification - Intermediate Load Applications -
(January 15, 1980).

3.0 Requirements

3.1 Functional Description

The module specified herein shall be used to convert solar energy
to electrical energy in terrestrial applications.

3.2 Performance

The photovoltaic module shall provide the required power output
when subjected to the specified test conditions.

3.2.1 Power Output

Configuration	Power Output	
	Minimum Lot Average	Module Minimum
-1	33 Watts (2.04 amps)	31.5 Watts (1.94 amps)
-2	66 Watts (4.07 amps)	63 Watts (3.89 amps)

3.2.2 Test Conditions

Solar intensity	-	1000 W/m ² , AM 1.5
Cell temperature	-	28° C minimum
Test voltage	-	16.2 volts minimum

3.3 Design

3.3.1 Electrical Design

All module circuitry, including output terminations shall be insulated
from the electrically conductive external surfaces. Leakage current

shall not exceed 50 microamps when a potential of 3000 VDC is applied between the external conductive surface and the output terminals.

3.3.1.2 Electrical Interface

Each terminal on the module shall be equipped with an AMP SOLARLOK connector bus bar housing No. 121044-1. The polarity of each socket shall be clearly marked in a permanent and legible manner. Positive and negative terminals shall be located at opposite ends of the module.

3.3.1.3 Bypass Diode

Each module shall have at least 3 encapsulated bypass diodes. Each diode shall be connected in parallel across no more than 12 series connected solar cells. The forward direct current capacity of the diodes shall be greater than 1.1 times the module short circuit current and derated for a temperature of 75° C. The peak inverse voltage rating of the diode shall be not less than 1000 volts. The diode shall be designed and mounted so that heat generated from diode forward current operation shall not damage the module.

3.3.1.4 Reliability and Redundancy

The module shall meet or exceed the reliability and redundancy requirements of Section II, Part B, Paragraph 4 of the referenced JPL Specification 5101-83.

3.3.2 Mechanical Design

.3.2.1 Geometry

Overall dimensions and hole locations shall conform to Figure 1.

3.3.2.2 Optical Surface

The illuminated optical surface of the module shall be tempered low iron glass and shall conform to the requirements of Section II, Part C, paragraph 3 of the referenced JPL Specification 5101-83.

3.3.2.3 Interchangeability

All modules shall be physically interchangeable.

3.3.2.4 Defects

3.3.2.4.1 Rejections

Modules with the following defects shall not be accepted:

- a) Cracked or broken front surface
- b) Cracked or broken frame
- c) Cracked or broken solar cells
- d) Cracked or broken interconnects
- e) Cells with unsoldered solder joints
- f) Laminate voids greater than 1/4 inch diameter and 1 square inch total area per module
- g) Loose or broken terminals
- h) Broken diodes or diode connections

3.3.2.4.2 Allowable Cosmetic Defects

At the discretion of Hughes, selected cosmetic defects which do not affect form, fit, function or reliability may be permitted.

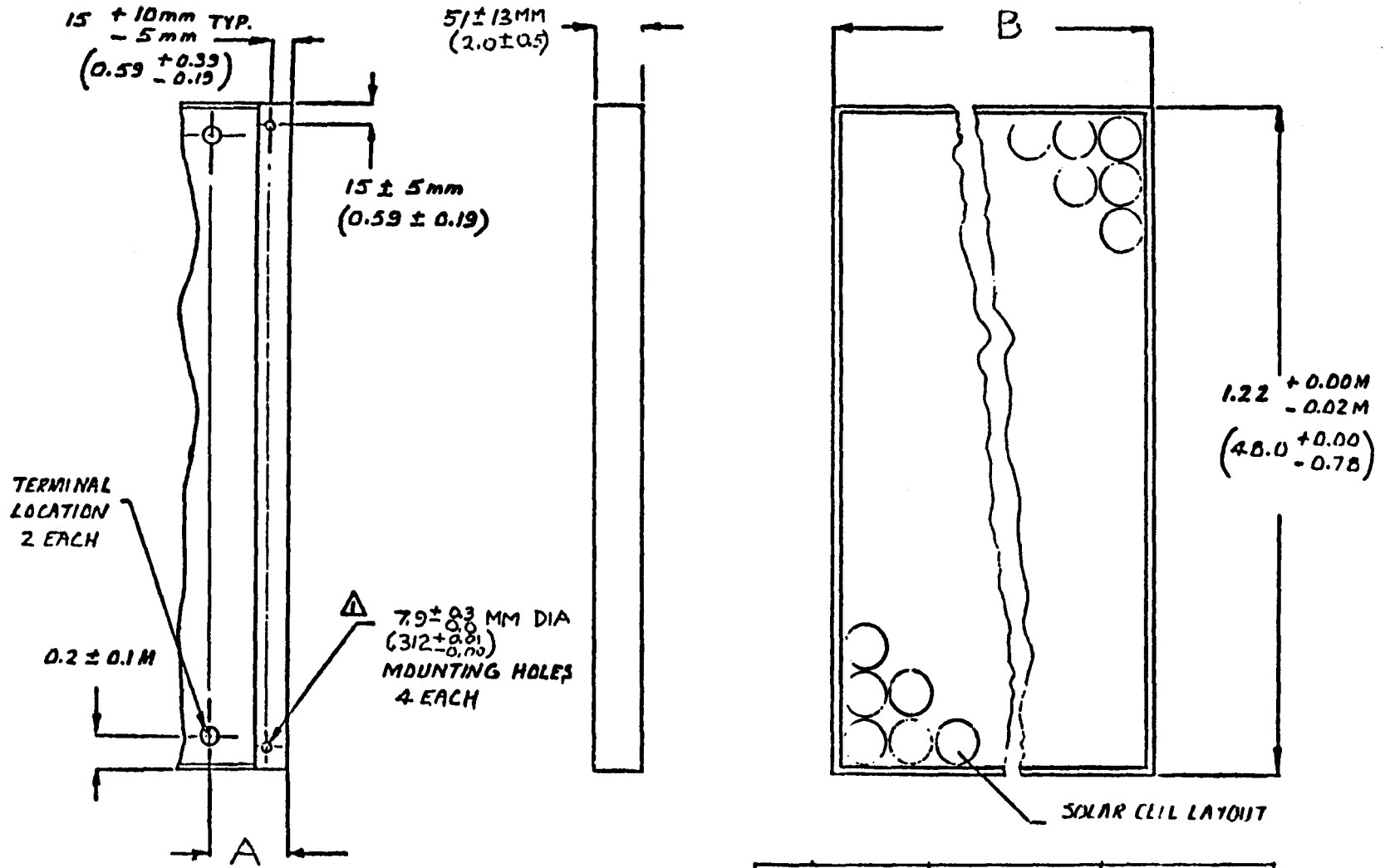

NOTES:

- ▲ MOUNTING HOLES MUST BE LOCATED IN MODULE SIDE FRAME MEMBERS ONLY.
- 2. DIMENSIONS IN PARENTHESES IN INCHES.

DIMENSION	-1	-2
A	0.15 ± 0.07M (6 ± 3)	0.3 ± 0.2M (12 ± 8)
B	0.30 ± 0.00M - 0.02M (12.0 ± 0.00) - 0.75)	0.61 ± 0.00M - 0.04M (24 ± 0.00) - 1.50)

FIGURE 1.0 MODULE STANDARD DIMENSIONS

3.4 Operational Life

The module shall be designed for an operational life of at least 20 years.

3.5 Environment

As a minimum the module design shall be capable of withstanding exposure to the environmental tests defined in Section V of reference JPL Specification 5101-83. The module shall also be capable of meeting the requirements of the Hot Spot Endurance Test of Section II, Part B, paragraph 5 of the JPL Specification 5101-138.

3.6 Identification

Each module shall be legibly identified with the following:

- a) Seller part number
- b) Serial number
- c) Current at test voltage
- d) Month and year of manufacture

4.0 Quality Assurance Provisions

4.1 General

The product covered by this specification shall be subject to inspection and testing by both the seller and Hughes in accordance with the quality assurance provisions of this section.

4.1.1 Interface Control Drawing (ICD)

Prior to the manufacturing of modules for this Hughes program, the vendor shall generate an "Interface Control Drawing" (ICD). This drawing shall identify the configuration, dimensions, parts and materials used in module fabrication. This ICD shall be submitted to Hughes for approval prior to module fabrication. Any changes thereafter to the ICD shall be submitted for approval to Hughes prior to intended implementation of such changes.

4.2 Requirement Verification

4.2.1 Test and/or Inspection

Requirements specified in Section 3 of this specification and listed in 4.2.3 (Requirements/Specification Matrix) shall be verified by the applicable paragraphs of Section 4.

4.2.2 Certification

Requirements specified in Section 3 of this specification not verified by inspection or test shall be satisfied by a submittal to Hughes of documentation showing evidence of conformance in the form of data and/or test reports.

4.2.3 Requirements/Verification Matrix

<u>Requirements</u>	<u>Title</u>	<u>Verification Method Paragraph No.</u>
3.2	Performance	4.4.2
3.3.1.1	Electrical Voltage Insulation	4.4.3
3.3.1.2	Electrical Interface	4.4.1
3.3.1.3	Bypass Diodes	4.2.2
3.3.1.4	Reliability and Redundancy	4.2.2
3.3.2.1	Moisture Protection	4.2.2
3.3.2.2	Geometry	4.4.1
3.3.2.3	Optical Surface	4.4.2
3.3.2.4	Interchangability	4.2.2
3.3.2.5.1 (a-g)	Rejections	4.4.1
3.3.2.5.1 (h)	Broken Diodes or Diode Connections	4.4.1/4.4.4
3.4	Operational Life	4.2.2
3.5	Environment	4.2.2
3.6	Identification	4.4.1

4.3 Inspection and Test Methods

4.3.1 Hughes Source Inspection

The Hughes Aircraft Company, may, at its option, provide inspection to monitor the seller's quality control procedures. The completed hardware may be source inspected by Hughes to assure that the product conforms to all the requirements specified on the applicable drawings and specifications.

4.3.2 Test Location

Unless otherwise specified in the contract, acceptance tests shall be performed by the seller at the seller's plant. If the use of outside test facilities is required, such use shall be subject to prior approval by Hughes. Hughes shall have the right to witness, inspect and review all acceptance tests.

4.3.3 Test Conditions

Unless otherwise specified herein, all tests shall be performed at the following nominal ambient conditions:

- | | |
|----------------------|-------------------------------|
| a) Temperature | +25 degrees \pm 5 degrees C |
| b) Relative humidity | No greater than 50% |

4.3.4 Test Equipment

4.3.4.1 Test Equipment Accuracy

All meters, scales, thermometers and similar measuring equipment used in conducting tests specified herein shall be accurate within one percent of full-scale value except temperature which shall be accurate within $\pm 1^{\circ}\text{C}$. Full-scale deflection of meters shall not be more than twice the maximum value of the item being measured.

4.3.4.2 Test Equipment Calibration

All test apparatus shall be calibrated at proper intervals and records of such calibration shall be available for Hughes inspection. Hughes may examine the seller's test equipment and determine that they are of the proper type and range to make measurements of the required accuracy and are in calibration.

4.3.4.3 Solar Simulator

The solar simulator shall be capable of simulating air mass 1.5 spectral conditions and a solar radiation intensity of 1000 W/m^2 . The solar simulator intensity shall be calibrated and verified using a Hughes approved standard solar cell which is traceable to a JPL calibrated standard. The simulator may be either a constant xenon light source or pulsed xenon type.

4.4 Acceptance Tests

4.4.1 Examination

Each module shall be visually inspected for compliance to the following paragraphs: 3.3.1.2, 3.3.2.2, 3.3.2.5, 3.6, and the ICD (4.1.1).

4.4.2 Electrical Performance

The seller shall test each module under the test conditions specified in paragraph 3.2.2 to verify the output requirement of paragraph 3.2.1. The solar simulator used for this test must comply with paragraph 4.3.4.3.

A full current-voltage (I-V) characteristic curve is required for each module. If a pulsed xenon type simulator is utilized, a minimum of 5 data points along the I-V curve is required including short circuit current, current at rated voltage and open circuit voltage.

4.4.3 Electrical Voltage Insulation Test

Each module shall be subjected to a "Hi-Pot" test conducted with the output terminations shortcircuited. The leads from a suitable dc voltage power supply shall be connected with the positive lead on the terminals and the negative lead on the module frame. Voltage shall be applied at a rate not to exceed 500 V/sec up to the test voltage of 3000 Vdc, and then held at this test voltage for at least 1 minute. The module shall be observed during the test and there shall be no signs of arcing or flashover. Leakage current shall be monitored during the test and shall not exceed 50 microamps.

4.4.4 Diode Verification Test

A diode verification test shall be performed on each module to insure that none of the bypass diodes or their associated connections have open or short circuits. The procedure for this shall be submitted to Hughes by the Seller for approval prior to performance of this test.

4.4.5 Hughes Electrical Performance Tests

Upon preparation for shipment of each lot of modules Hughes will randomly select one module for each 25 modules in the lot. These selected modules will be retested by Hughes in accordance with paragraph 4.4.2. If the Hughes average values of power at the test voltage for the sampled modules vary from the vendors values by more than 2%, acceptance of the shipping lot shall be withheld pending further testing and investigation.

4.5 Rejection and Retest - Production Modules

4.5.1 Rejected Modules

Rejected modules shall not be resubmitted for acceptance without furnishing full details concerning the rejection, the measures taken to overcome the defects, and the prevention of their future occurrence. Each rejected module shall be identified by a serialized rejection tag. This rejection tag shall not be removed until rework requirements have been complied with.

4.5.2 Defective Modules

Notwithstanding the warranty of individual modules, if, after receipt by Hughes, a significant number of modules prove defective, such as to indicate a vendor manufacturing problem, the entire lot may be rejected.

4.5.3 Retest

Any unilateral changes from Paragraph 4.1.1 by the supplier in manufacturing techniques, processes, materials, quality control levels, or type of manufacturing equipment shall be cause for rejection of subsequent modules.

4.6 Test Records

Records shall be kept of all tests and of all applicable manufacturing data, and these records shall be made available to Hughes. All physical markings, defects and other visual characteristics shall be noted and recorded as a portion of the test record. The I-V curve for each module shall be delivered to Hughes.

5.0 Preparation for Delivery

5.1 Packaging

5.1.1 The Seller shall package the modules into shipping containers which adequately protect the modules from shipping damage.

5.1.2 Module containers shall be assembled onto and tied down to a pallet for shipping and storage.

5.2 Marking

Each module shipping container shall be legibly identified with the following:

- a) Hughes part number (specification number).
- b) Seller's part number, serial number(s) and quantity of modules.
- c) Lot number if applicable.
- d) Month and year of manufacture.

6.0 Warranty

The contractor shall warrant that the solar cell modules offered will be free from defects in material, workmanship, and performance for a period of not less than two years after acceptance by Hughes Aircraft Company. During the warranty period all modules found to have defects not caused by misuse or accident through fault or negligence by Hughes or end user must be replaced at Seller's expense.

PROTECTIVE GROUNDING - A. F. Dickerson

Lightning is a diverse phenomena, made more diverse by the variations in topology at the earth's surface - it is not surprising that a finding under one set of conditions is sometimes misapplied to a different circumstance in which the original finding is invalid because of altered conditions. As an example, consider the statement "tall structures attract lightning, therefore if I put a lightning rod (tall structure) on my house there will be more lightning strikes on my property." This statement may or may not be true depending upon the height of your house and the lightning rod and the height of adjacent structures.

Let's examine the generally accepted sequence 1, 2, 3, leading up to a strike. Negative charges build up on the major portion the bottom of a cloud (there are various theories as to why, but they do). Positive charges are induced at the surface of the earth under the cloud. In general, charge mobility on the earth is much greater than that in the cloud. Accordingly, the potential difference between earth and cloud increases until a "pilot leader" or "step leader" initiates a relatively slow moving conducting channel. The pilot leader advances in spurts of 10-200 m at intervals of 40-100 μ S.² Each branch of the leader is probing for any optimum path between cloud and earth, some are abandoned and new paths tried giving the typical "forker" appearance seen in photographs. This process continues until the head of the leader is roughly 100 m from the earth (or its elevated structures). This progress will have consumed perhaps 20 μ S and up to this point the leader has no specific strike point - it is simply chasing positive space charge.

Meanwhile on the earth (if the leader is coming from the cloud) a further movement of charges occurs from the displacement current created by the advancing leader. The closer the leader approaches, the more concentrated are the charges owing to both decreased area and increased current. Eventually the displacement current

is supplemented by point discharges from the earth wherever there is a concentration of electric field. At this point one or several arcs form and move upward to meet the step leader. The one which meets the step leader 50-70 m above the earth determines (by its point of origin) the point where we say lightning struck. The main discharge or return stroke occurs rapidly after the two leaders meet. The damage occurs in the return stroke.

It is worth noting that the cloud chiefly determines the timing and the general area of the strike, the field configuration at the surface of the earth determines the specific spot within that area.

As an example of extremes let's consider on one hand the Empire State Building and on the other a groundwire canopy 10 m above a metallic structure 5 m in height and 100 m x 100 m in surface extent, such as a large PV array. At a height exceeding 1000 ft., and with a high ratio of height-to-width in the upper structure, the Empire State Building clearly alters the profile of electric potential on the earth side of the earth-cloud system. The concentration of electric field strength (potential difference per unit length) is generally approximated by the height to width ratio of any protuberance in any otherwise flat conducting plane. Thus the dimensions of the Empire State Building greatly multiply any electric field in the cloud-earth system with the greatest multiplication at the very top. The 1250 foot height is significant with respect to cloud-earth spacing of 2000 - 6000 ft. As a result it is not surprising that the Empire State Building is struck by lightning with greater-than-normal frequency. One study⁷ has shown that in 80% of the strikes, the building originated the step leader not the cloud. One might say that the Empire State Building not only attracts lightning, it generates it!

In contrast consider a 100 m x 100 m PV array structure 5 meters in height. As a protuberance on an otherwise flat earth, it enhances the electric field by (5/100) or 5%. We should expect that the structure will be struck with slightly greater

than an open earth of 10^4 square meters in the immediate vicinity. The upper corners of the supports have a relatively high height-to-width ratio and thus will most frequently be the points from which the arc proceeds upward to meet any step leader which occurs in the array's area. In short, the existence of the structure may have a negligible effect of strike rate, but it insures that any strikes which do occur in the immediate area will hit the array.

Now let's suspend 10 ground wires (at 10 m intervals) over the array structure at a total height of 15 m. These wires are tied to a good local ground, for example, a counter poise under the array. The support structures are in turn tied to the counterpoise also. Thus, the array exists in a field - free region between the overhead grid and the earth - counterpoise ground. The concentration of field will be slightly increased. However, in the context of a 600 - 2000 m cloud-to-earth spacing the additional 10 m is trivial. However, what has been accomplished is the near 100% assurance that strikes which occur in the area will hit the ground wires and will not hit the array.

Some idea of the effect of structure height may be gained from a Westinghouse study⁴ which concluded that probability of strikes increased linearly with height from 50 - 500 feet. For heights greater than 500 feet, the probability increased much more than linearly. As in example the Empire State Building, (1250 ft.) experienced an average 23 strikes/yr., while 10 towers of 100 ft. experienced 0.2 strikes/yr. This is a 100:1 difference in rate for a 12:1 difference in height.

An examination of the Westinghouse data leads to an interesting observation. A single mast 15 m high has the same strike probability as a $4,000 \text{ m}^2$ structure only 3 m high. In short, the 5:1 increase in height is offset by the approximately 1:5 difference in equivalent area (assuming the mast has an equivalent area of a circle with $r =$ to the mast height). This gives credence to the view that for small heights strike probability is roughly proportional to area of the structure and also proportional to

height above the earth.

The question of spacing for overhead ground wires has been examined by Wagner⁵. Based upon extensive records of lightning induced outages on electric power transmission systems with overhead ground wires, Wagner concludes that for an isokeraunic level of 30, failures per 100 miles of line approximate zero for a total protective angle of 45 degrees rising to 1/2 per year at 60°, 2 per year at 75° and 7 per year at 90° - a yearly exponential increase. For a 53° protective angle the spacing between overhead wires would equal their height above the protected structure. Waldorf⁶ found that strokes to power lines (in an area of isokeraunic level 30-40) averaged 126 strokes per 100 miles per year. If we take the ratio of outages to the average number of strokes as a percentage this yields approximately 0.1% for overhead wire with spacing equal to their clearance. Westinghouse⁴ considers this a point of reasonable diminishing returns.

The overhead canopy of ground wires appears to offer a very cost-effective protection scheme for PV arrays.

SUMMARY

For structures of modest height, the cloud chiefly determines the timing and general area of a strike, while the configuration of a structure (and its protection) determine the specific point of strike.

An extensive, low-lying structure such as a photovoltaic array will experience lightning strikes in proportion to the local isokeraunic level and the area of the array. Without overhead ground wires, the corners of the array structure represent likely strike points. With several overhead ground wires spaced equal to their clearance above the array, the strike probability to the array may be made negligibly small by diversion of the strike to the ground wires. If the ground wire clearance is modest, (comparable to array height) the increased strike probability to the area will be slight.

REFERENCES

- ¹W.W. Lewis, "The Protection Of Transmission Systems Against Lightning" J. Wiley & Sons, 1943.
- ²J.L. Marshall, "Lightning Protection" J. Wiley & Sons 1973.
- ³D.G. Fink, "Standard Handbook For Electrical Engineers", McGrawhill 1968
- ⁴Westinghouse Editorial Service, Proc. IRE, Feb. 1943.
- ⁵C.F. Wagner, "Lightning And Transmission Lines" J. Franklin Inst. 283, No. 6 June 1967.
- ⁶S.K. Waldorf, "Experience With Preventive Lightning Protection" Trans. Electrical Engr. V. 60 June 1941, pp. 249-254
- ⁷K.B. McEachron, "Lightning To The Empire State Building" AIEE Transactions, Vol. 60, pp. 885-889