

GASEOUS ELECTRODE DEVELOPMENT

Quarterly Report for the Period  
July 1 - September 30, 1979

REYNOLDS METALS COMPANY  
Energy Conversion Division  
P. O. Box 1200  
Sheffield, Alabama 35660

October 1979

Prepared for the  
UNITED STATES DEPARTMENT OF ENERGY  
Under Contract No. EX-76-C-01-2476

## **DISCLAIMER**

**This report was prepared as an account of work sponsored by an agency of the United States Government. Neither the United States Government nor any agency thereof, nor any of their employees, makes any warranty, express or implied, or assumes any legal liability or responsibility for the accuracy, completeness, or usefulness of any information, apparatus, product, or process disclosed, or represents that its use would not infringe privately owned rights. Reference herein to any specific commercial product, process, or service by trade name, trademark, manufacturer, or otherwise does not necessarily constitute or imply its endorsement, recommendation, or favoring by the United States Government or any agency thereof. The views and opinions of authors expressed herein do not necessarily state or reflect those of the United States Government or any agency thereof.**

---

## **DISCLAIMER**

**Portions of this document may be illegible in electronic image products. Images are produced from the best available original document.**

TABLE OF CONTENTS

---

	<u>PAGE</u>
1.0 PROJECT OBJECTIVE .....	1
2.0 PRIOR ACCOMPLISHMENTS .....	2
3.0 PRESENT GOALS .....	3
4.0 CURRENT ACCOMPLISHMENTS .....	4
4.1 Study of the Microwave Gaseous Electrode Concept .....	4
4.2 Procurement of Microwave Hardware and Design of Model I of MGE .....	4
4.3 Combustor Performance and Modifications .....	5
4.4 Instrumentation and Controls Modification .....	7
5.0 FUTURE SCHEDULE .....	11
6.0 REFERENCES .....	12

## 1.0 PROJECT OBJECTIVE

The main goal in this project is to demonstrate the feasibility of using gaseous electrodes in an MHD channel and to determine the optimum conditions for their operation. Previous work on this program has established that, to meet such an objective, the gaseous electrodes must be designed using plasma sources that operate continuously and which show a promise of operating successfully in an MHD channel environment. A new approach to the gaseous electrode concept that appears to hold a high probability of success and has various options for implementation uses microwave generated plasma sources. This was first described by Scannell.<sup>1</sup> This new approach is now being pursued. A commercialization of this concept requires, as a minimum, that the following steps be met:

- A. Demonstration that the gaseous electrode can markedly decrease the plasma to electrode voltage drops. This will require operation of one or more microwave gaseous electrodes in a functioning MHD channel under power generating conditions. Since there are several ways that the microwave gaseous electrode concept can be configured, this phase will involve comparative testing of the separate approaches on both the bench scale and in the MHD channel. The tests in the MHD channel will cover both a determination of how operation of the microwave gaseous electrode affects the overall characteristics of the channel, and what it specifically does to the electrode voltage drops. The physical conditions associated with the large electrode voltage drops are the major factor in causing electrode erosion.
- B. After showing that the gaseous electrode can alleviate the major cause of electrode erosion, the next step is the application of the gaseous electrode technique to an entire channel, or the major portion thereof. Some analytical work and experimental testing will be required to determine the optimum configuration of the individual gaseous electrodes and their arrangement in the MHD channel. Installation of the gaseous electrode in the channel may not require the application of the gaseous electrode technology to each electrode segment. The effect of ash carryover on the operation of the microwave gaseous electrode system must also be evaluated. Developmental testing will be required to determine the optimum placement of the microwave gaseous electrodes within the generator and to evaluate the effects of inter-electrode breakdown. The objective of this phase is to demonstrate the total effect on the MHD channel of using the microwave gaseous electrode throughout the generator.
- C. The final phase is to demonstrate that the gaseous electrode is able to operate for appreciable periods of time in a working MHD generator environment. Two thousand hours is the currently accepted goal for MHD electrode operation; however, longer term operation, if it could be achieved, would indicate the superiority of the gaseous electrode.

## 2.0 PRIOR ACCOMPLISHMENTS

During the second quarter, tests were conducted to evaluate the performance of the 1/4"-diameter arc gaseous electrode (AGE) in the MHD channel. The major conclusions from those tests can be summarized as follows:

- A. High speed photography and fiber optic diagnostics on the arc gaseous electrode revealed that its operation in the channel was at best sporadic and at no time was the electrode slot completely filled with an ionized gas. Fiber optic monitoring of the arc translational and rotational frequencies clearly showed that the arc tended to rotate at one spot on the cathode with no translational movement. It was concluded that this behavior was due to an adverse pressure gradient between the arc chamber and the MHD channel immediately above it causing flow matter such as seed material to migrate into the arc cavity and considerably disrupt the mechanics of the arc operation.
- B. Operation of the arc gaseous electrode had no discernible effect on the generator parameters such as the axial voltage profile, open circuit voltage or short circuit current. This is not totally unexpected since the arc plasma, even under the most stable operating conditions, can be characterized as a non-uniform plasma source and under MHD channel conditions its performance degrades considerably, as explained above. However, it is not implied here that the operation of a single gaseous electrode in the MHD channel with a stable, uniform, plasma source will have dramatic effects on the generator electrical parameters. The diagnostics for evaluating such a gaseous electrode are outlined in Reference 2.
- C. Based on fiber optic diagnostics and time resolved current measurements through the electrode frame, it was learned that the current is transmitted to the electrodes through a series of pulses of peak amplitude of about 100 A and pulse duration of 100 msec. The d.c. or steady state value of the pulse current was 6 amps. It was suggested that these high amperage "sparks" were responsible for the electrode erosion.

Additional details on the bench and channel performance of AGE are available in Reference 3. However, based on all the experiments that were conducted with AGE in the channel, it became apparent that if the gaseous electrode concept were to be effectively implemented, then a stable, spatially uniform, and continuously operating plasma source must be used. This has, therefore, led to the design and development of the next generation of gaseous electrodes utilizing microwave plasma sources.

### 3.0 PRESENT GOALS

During the third quarter of 1979, the following tasks were set:

- A. Make a study of possible approaches for implementation of the microwave gaseous electrode (MGE) concept in the MHD channel.
- B. Procure microwave hardware; design and fabricate bench scale model of microwave plasma torch. Also commence design of MHD window frame for Model I of MGE.
- C. Improve combustor performance.
- D. Upgrade instrumentation capability of facility.

#### 4.0 CURRENT ACCOMPLISHMENTS

The tasks that have been accomplished during the third quarter of 1979 are described below under separate headings.

##### 4.1 Study of the Microwave Gaseous Electrode Concept

Early in the quarter, several models of the microwave gaseous electrode were identified that appeared to hold great promise for demonstration of this concept under MHD channel flow conditions. These included

- (a) Microwave plasma torches feeding a cylindrical cavity with injection of ionized gas into the MHD channel from a slot (Fig. 1).
- (b) Microwave plasma torches injecting directly into the channel boundary layer (Fig. 2).

Approaches (a) and (b) are different adaptations of the microwave plasma torch first described by Cobine.<sup>4</sup> Electrode design in (b) is based on a version suggested in the patent application of Scannell.<sup>1</sup> Both approaches will be tried at the commercial and industrial microwave frequency of 2.45 GHz, since sources with large CW microwave power output are easily obtained at this frequency. Further details on these approaches are described in Reference 2.

##### 4.2 Procurement of Microwave Hardware and Design of Model I of MGE

During the months of August and September, procurement was authorized for two CW microwave sources operating at a frequency of 2.45 GHz. The output of one source is 400 W and is to be installed in the Electrode Development Facility for bench scale tests on different versions of the microwave gaseous electrode. The output of the second source is 2.5 kW and will be located in the Generator Test Facility (GTF) and is intended for channel testing of the microwave gaseous electrode. Also, the high power source will have the capacity to power a multiple gaseous electrode system under channel conditions. Meanwhile, procurement has also been authorized for essential microwave test equipment and is expected to arrive during the months of October and November.

The design of a bench scale model of the microwave plasma torch has been completed and the drawings (see Fig. 3) have been submitted for fabrication. The scheduled date of completion of a prototype model of this torch is middle of October. The fabrication of the torch involves the joining of two copper or brass coaxial lines to form a tee section. A tuning plunger fitted with contact fingers is located at one end of the straight section of the torch and its travel along the coaxial line can be controlled by mechanically operating a handle attached to it or actuating a thumb screw for fine movement. The center conductor of the straight section is fitted with a conical electrode tip made of tungsten, the latter material being chosen because of its high melting point (3410°C). The portion of the outer conductor surrounding the tungsten tip is a removable nozzle section that can be made for different convergent angles. The tungsten tip is water cooled by circulating

water through a tube located concentrically inside the center conductor of the coaxial tube and in the region between this tube and the inside of the inner conductor. Cooling is also provided for the top surface of the outer conductor. Gas inlet to the torch is through two tangential 1/8" holes located on the outer surface of the torch. By injecting the gas tangentially, a swirl will be created so that the gas may exit uniformly into the discharge zone.

During this quarter, design work on Model I of the microwave gaseous electrode has also commenced. The window frame is being designed in four separate pieces so as to accommodate any refinements in the design that may be conceived at a later date. This flexibility in the design allows plasma torches to be located in the anode or cathode wall. Also, it is intended that the design be such that the assembly and disassembly of the plates in the channel may be accomplished with a minimum of dismantling time. The window frame is 1.25" in width and replaces Plates 53-55 in the channel. No "yaw" angle is required in the window frame design.

Towards end of the quarter, design of the gaseous electrode section of the window frame for MGE-I was completed and a drawing (see Fig. 4) is to be submitted for fabrication purposes. This section of the window frame has a 0.875" hole drilled through it for purposes of inserting two microwave plasma torches. Provision is made to seal one end of this hole with a water cooled plug is only one torch is used. A slot is cut on top of the electrode that allows ionized gas from the electrode cylindrical cavity to exit into the MHD channel. The slot is fitted with a slotted plate which permits changes in the slot exit area and also the direction of the ionized gas injected into the channel. Provisions are also being made to monitor the pressure in the electrode cavity along with that in the MHD channel immediately above the slot.

#### 4.3 Combustor Performance and Modifications

The operation of the MHD generator test facility during the course of arc gaseous electrode testing disclosed that the available combustor volume is insufficient for complete combustion. The theoretical calculations indicate that the present combustor volume for the design mass flow provides only 4 msec of gas residence time which is substantially less than that required for complete combustion. Further, the gas residence time required for seed evaporation and ionization is longer than that required for complete combustion, of the order of 24 msec. By decreasing the  $N_2/O_2$  ratio, that is by increasing the gas temperature in the combustor, it is possible to reduce the gas residence time requirements somewhat. But, in any case, it is necessary to increase the combustor volume. This can be accomplished either by designing a new larger diameter combustor or increasing the length of the present combustor. Increasing the length of the combustor involves only a modest expenditure, but the heat losses from the combustor will increase. There is a practical limit as to how far the combustor can be extended since the enthalpy gain with complete combustion is nullified by increased heat losses. By installing a ceramic liner in the combustor the heat losses can be reduced. Therefore, a liner about 4 mm thick of Kaiser Refractories Corpatch 95, which is a castable ceramic, was installed and carefully cured following the time-temperature profile shown in Fig. 5. The combustor with the liner was then operated for several hours at various thermal input levels. The material apparently bonds well to the copper liner. No cracks were found in the liner.

after about 20 thermal cycles, and the seed apparently does not chemically attack this ceramic material.

To improve the flow measurement capability, the vortex shedding flow meters, purchased under 1978 Capital Authorization CD-2, were installed. The necessary flow system modifications, installation of the control valves, and the checkout of the revised system have been completed. Using these new flow meters, the orifice meters in the system were recalibrated and the calibration graphs are shown in Figs. 6-8. The figures also show the calibration graphs used earlier for estimating oxygen and nitrogen flow rates. The error in the nitrogen flow rates was larger compared to that for oxygen.

The orifice meter in the N<sub>2</sub> flow line was also calibrated for air flow using the new flow meter. The air flow for the calibration was obtained from a rented 600 cfm portable air compressor. It was found that the operation of flow meters is sensitive to moisture content in the air flow, therefore the air flow must be dry and clean. Hence, if an air compressor is to be used for extended MHD generator testing, an air dryer and filter are essential in the air flow line. The replacement of liquid nitrogen with compressed air flow for long duration tests will substantially reduce the expenses. It is estimated that for a 2000-hour test at full load on the MHD generator, a 50% savings can be realized (see Table I).

A number of difficulties were faced earlier when trying to start the combustor using the natural gas igniter. Therefore, the igniter was switched from natural gas to propane, and works satisfactorily every time. The modifications made for the O<sub>2</sub> and N<sub>2</sub> flow system inside the test facility to accommodate the combustor extension are shown in Fig. 9.

To further define the combustion gas residence time requirements and at the same time to evaluate the ceramic liner performance with respect to thermal shock, the MHD combustor was operated for a number of hours, most of the time at low mass flow rates, the flow rate being about 0.3 kg/sec which is about one-third the design flow rate. Samples of gas were collected at the combustor exit and a detailed quantitative analysis of the various gaseous species was made using a Beckman GC-2 gas chromatograph.

The chromatographic system employs two columns in series, with a detector at the exhaust end of each column. Signals from the two detectors are fed to a standard millivolt recorder. The gas chromatograph uses a 30" hexamethyl phosphoramide (HMPA) column in the column 1 position, and a 6.5' molecular sieve 13X column in the column 2 position. Helium was used as a carrier gas. The concentration of carbon dioxide, oxygen, nitrogen, methane, and carbon monoxide was determined.

Figure 10 shows the concentration of CO<sub>2</sub>, CO, and O<sub>2</sub> for various equivalence ratios. The CO<sub>2</sub> concentration as expected shows a maximum near stoichiometric mixture ratio. The dry volume percentage of CO, CO<sub>2</sub>, and O<sub>2</sub> determined for various oxygen to nitrogen ratios for a total mass flow rate of about 0.25 kg/sec is shown in Fig. 11. Increasing the oxygen to nitrogen ratio will increase the gas temperature and therefore reduce the required residence time for complete combustion. That is, for a given volume in the combustor and for a given mass flow, the higher the oxygen-nitrogen ratio, the more complete is the combustion process. The variation of oxygen in the exhaust reflects the

above physical process. Due to increased gas temperature, the carbon monoxide concentration level has also increased due to dissociation. Further, for comparison purposes, the residual oxygen present at the combustor exit for various gas flow rates is shown in Fig. 12 for both diesel and propane fuels. For a given mass flow, the propane shows lesser oxygen content at the combustor exit than the diesel fuel, thus indicating more complete burning with propane for the same mass flow rate.

The plasma conductivity measurements were made with the combustor liner in place. Figure 13 shows the electrical circuit for the plasma conductivity measurement. The measured voltage distribution and the plasma conductivity profiles along the channel are shown in Fig. 14. The conductivity profile clearly shows the increased plasma conductivity with the increased oxygen-nitrogen ratio.

#### 4.4 Instrumentation and Controls Modification

##### 4.4.1 Installation of O<sub>2</sub>-N<sub>2</sub> Gas Delivery System

The present system is shown in Figs. 15 and 16. The oxygen-nitrogen flow control system which had been used through the second quarter had serious deficiencies. These are outlined below:

- o Gas flow rate was estimated by the amount of pressure drop across an orifice, leading to inaccuracies due to the inherent limited range of an orifice (approximately 3:1 turndown), and the limited resolution of readout equipment.
- o The flow control valves are motor-operated ball valves which have extremely poor throttling characteristics and which do not have fail-safe capabilities.
- o The oxygen safety shut-off valve (a pilot-operated, solenoid valve) is completely unsuitable for this type operation because it requires a 10 psi minimum pressure differential; it will not stop flow in the reverse direction; and it has a Buna-N diaphragm which is not suitable for oxygen service. The nitrogen system does not have a shut-off valve.
- o The over-all system design is extremely poor since the throttling valves are located upstream from the orifices, which are upstream from the shut-off valve. This is the exact opposite of the way it should be. Also, the orifices are welded in place, preventing calibration checks and replacement.
- o The threaded stainless steel pipe, installed downstream from the ball valves, is almost impossible to keep from leaking.

We are in the process of upgrading the system to remove the deficiencies and hazards outlined above. The revised system is shown in Fig. 17. The present maximum flow rate is 800 SCFM from each system. The new system is designed for a maximum flow rate of 1600 SCFM at normal operating conditions, allowing for future expansion. The following modifications and procedures will be involved in converting to the new system:

- o Flow rate will be converted from actual CFM (volume flow rate) to kg/sec (mass flow rate) by compensating for pressure and temperature variations through the use of analog function modules.
- o All major components of the flow delivery system are flange mounted for ease of assembly and maintenance. All threaded fittings are hand-tightened and then sealed with jam-nuts which have Teflon inserts. This forms a pressure-proof, gas-tight connection without the normal jamming action of pipe threads, allowing for long thread life and easier disassembly.
- o No pipe dope or tape is used in the installation, preventing interference with the flow meters or valve operation.
- o All components will be disassembled and cleaned with trichlorethane, using lint-free, 100% cotton wipes. All seats, seals, etc., will be re-lubricated with Fluorolube GR-362, manufactured by the Hooker Chemical Company. All parts not used immediately will be stored in plastic bags to prevent contamination.
- o Safety shutoff valves: 2" ball valves (Cv=120) of bronze and brass construction with Teflon seals, pneumatically operated with manual overrides. In the event of electrical or air power failure, the oxygen valve will automatically fail-safe to the "closed" position; the nitrogen valve will fail-safe to the "last-used" position.
- o Flow control valves: 1½" globe valves (Cv=28) of all bronze construction with Teflon seals. Equal percentage plug for best control at lower flows. These valves are equipped with pneumatic cylinder actuators and high gain positioners of the "balanced pressure" design. This type actuator gives positive high-resolution control while eliminating the "bath-tub stopper" effect common to pneumatic diaphragm actuators at low flow rates. Both valves are of the same construction and will fail-safe to the "closed" position, however, a solenoid valve will be inserted into the nitrogen valve's control line in order to allow it to fail-safe to the "last-used" position. The "last-used" fail-safe mode is desired in the nitrogen system in order to purge and cool the combustor in an emergency situation.
- o Flow Meters: 3" (1½-130 ACFM) vortex shedding flow rate meters of stainless steel construction with viton seals. These meters offer an accuracy of  $\pm 0.25\%$ , repeatability of  $\pm 0.1\%$  and linearity of  $\pm 0.5\%$  of reading. These meters are the only known gas flow meters that offer this accuracy.

A diagram of the existing system is shown in Fig. 18. Due to installation time and test schedule requirements, only that part of the new system dealing with the flow meters and their associated straight sections have been installed. The progress made during the third quarter is outlined below:

- o Flow meters and straight sections: Temporary installation has been completed.

- o Pressure transducers: Installed, amplifiers failed due to high temperatures, Action-Pak amplifiers presently being used.
- o Temperature transducers: Installed, probe sensors failed due to moisture in air, thermocouples are presently being used.
- o Flow converter: Breadboarded only.
- o Flow controllers: Action delayed to 1980 because of schedule requirements.

#### 4.4.2 Installation of Propane Leak Detector

After installation of the liquid propane fuel lines to the combustor, a failure occurred whereby a check valve, that should have prevented back-flow of propane into the nitrogen purge line, failed to close properly, and propane was vented into the magnet test area from the nitrogen pressure regulator.

It was then decided that a propane leak detection system was needed as a permanent installation and that some way of finding any such leaks was also needed. A portable (hand-held) electronic leak detector was purchased. This detector is sensitive to various gases such as propane, natural gas, freon, methane, methanol fumes, etc. In addition to this, a hydrogen gas sensing system that had been purchased several years ago was available for installation. This system is a highly reliable unit made by Mine Safety Appliance Corporation. It was determined that this unit was easily modified to detect propane gas and required only that a new sensing head and calibration kit be purchased.

#### 4.4.3 Channel-Combustor Heat Transfer and Cooling System Study

The present monitoring system for the MHD cooling system consists of 3% potentiometric pressure transducers monitoring inlet pressures and type K (chromel-alumel) thermocouples monitoring outlet temperatures. The original system considerations were for monitoring purposes only, and very low cost pressure transducers could be used as well as the fact that a large number of type K probes were on hand. In order to evaluate the MHD generator operation, it is necessary to determine the heat transfer between the MHD plasma and the walls of the combustor, channel, nozzle, and diffuser. To do this, it is necessary to know the inlet temperature as well as the outlet temperature, and to know the cooling water flow rate.

Line pressure surges were taken into account before buying potentiometric pressure transducers, but pipe vibration was not; therefore, the present transducers have been failing at an unusually high rate. The accuracy of the present transducers is inadequate for data purposes. The number of K type probes available has decreased drastically and each probe requires a reference junction and isolated amplifier.

The above named deficiencies can be remedied by making the following modifications:

- o Differential pressure transducers would be purchased and installed utilizing the present orifices and, where possible, this data would be sent to the cooling system monitor panel as well as the computer. Robinson-Halpern 10 psid units were selected as being the most cost effective. They offer  $\pm 0.5\%$  accuracy, 0 to 10 volt output and integral zero and span adjustments. They are not explosion or weather proof and have a maximum case pressure of 400 psi. They are LDVT type and require mounting in a steel cabinet.
- o Replacement water pressure transducers are being purchased and installed. The best unit appears to be the National Semiconductor LX1730GB, a 300 psig unit with a 2.5 to 12.5 volt output. This unit has basically a 2% accuracy and will require an external zero and span adjustment. It is expected that ambient temperature control will reduce the error to at least 1%.
- o Thermal measurements will be accomplished by using RTD sensors which do not require reference junctions or isolated amplifiers. A Lewis Engineering Company Model 56B4A, a nickel RTD meeting MIL-B-7990A, 4" stainless steel probe, stem sensitive, with integral 2-pin MS style connector will be used. This RTD has a basic accuracy of  $\pm 2.5\%$  which is adequate for monitoring purposes but not for data acquisition. A unique solution to this problem has been found which will reduce the error to approximately  $\pm 0.5\%$ .

#### 4.4.4 Installation of Additional Voltage and Pressure Points on Channel and Channel Load Switching

The present channel instrumentation includes one stagnation and 11 static pressure measurements and 10 plate voltage measurements. In order to more accurately define MHD channel operation, it has been estimated that at least 12 pressure and 10 voltage measurements be added. The pressure measurements can be achieved by purchasing or building a pressure scanning system that would be operated as a slave unit of the present Vidar scanner. This task will be completed during the first quarter of 1980. Additional taps for voltage measurements have been added.

For purposes of more accurately determining the MHD channel voltage profile, provision has been made for remote switching of the channel load.

## 5.0 FUTURE SCHEDULE

During the fourth quarter of 1979, it is anticipated that bench scale tests on the microwave plasma torch will begin. The tasks here will consist of:

- A. Initiating a discharge without a magnetic field.
- B. Studying the effect of a 1.5 Tesla magnetic field on the discharge.
- C. Varying other parameters such as type of gas, gas flow, input microwave power, etc.
- D. Characterizing discharge parameters such as temperature and density with Galprobe and Langmuir probe measurements.

Meanwhile, further tests will be conducted to evaluate the combustor performance, and upgrading of the instrumentation capability of the MHD facility will continue. One such task to be completed is the installation of flow meters and thermocouples for the measurement of the combustor cooling water flow rates and temperatures, respectively. It is also planned to provide for the measurement of voltages and pressures at an additional number of points along the channel so that increased resolution may be obtained in the voltage and pressure profiles. Provision will also be made to measure the transverse voltage profile which will enable us to determine the voltage drops due to aerodynamic boundary layers. The reduction of these voltage drops is one of the keys to increased electrode life.

Successful completion of the above tasks will then set the stage for demonstration of Models I and II of MGE under MHD channel conditions.

## 6.0 REFERENCES

1. Scannell, E. P., "Gaseous Electrode for MHD Generator," U. S. Patent Application, Ser. No. 829,506, June 12, 1979.
2. "Planning Document for Gaseous Electrode Development, July 1979 - December 1981," ECD Report, September 1979.
3. "Gaseous Electrode Development Annual Report," Reynolds Metals Company, Energy Conversion Division, Sheffield, Alabama, U. S. Department of Energy Contract No. EX-76-C-01-2476, August 1979.
4. Cobine, J. D. and D. A. Wilbur, "The Electronic Torch and Related High Frequency Phenomena," *Journal Appl. Phys.*, Vol. 22 (6), pp. 835-841, 1951.

TABLE I

COST COMPARISON OF N<sub>2</sub> + O<sub>2</sub> AND AIR + O<sub>2</sub> USAGE

OXYGEN AND NITROGEN USAGE

Oxygen - 48,600 CFH x 2,000 hours = 97,200,000 CF

Total cost of oxygen = \$306,924

Nitrogen - 49,680 CFH x 2,000 hours = 99,360,000 CF

Total cost of nitrogen = \$289,530

Total cost of oxygen & nitrogen without air compressors = \$596,454

AIR AND OXYGEN USAGE

Rental cost of 1050 CFM\* electric compressor:

\$10.57/hr x 2,000 hours = \$ 21,140

Rental cost of air dryer and filter:

\$5.00/hr x 2,000 hours = \$ 10,000

Additional oxygen required:

52 lb/min x 60 min x 2,000 hours = 6,240,000 lbs.

6,240,000 lb x 12.08 CF/lb = 75,379,200 CF

Minimum charge 1,000,000 CF/Mo. \$4,968 x 3 Mo. = \$ 14,904

72,379,200 CF remaining x \$.31/100 CF = \$224,375

Total cost of oxygen & nitrogen using air compressors = \$270,419

Net savings by using air compressor (excluding fuel or electricity cost for air compressors) =

\$326,035

If diesel engine is used, an estimated 12 gal/hr x 2,000 hours = 24,000 gal x \$.85 = \$20,400 is needed for diesel fuel cost. Electricity would probably be much less.

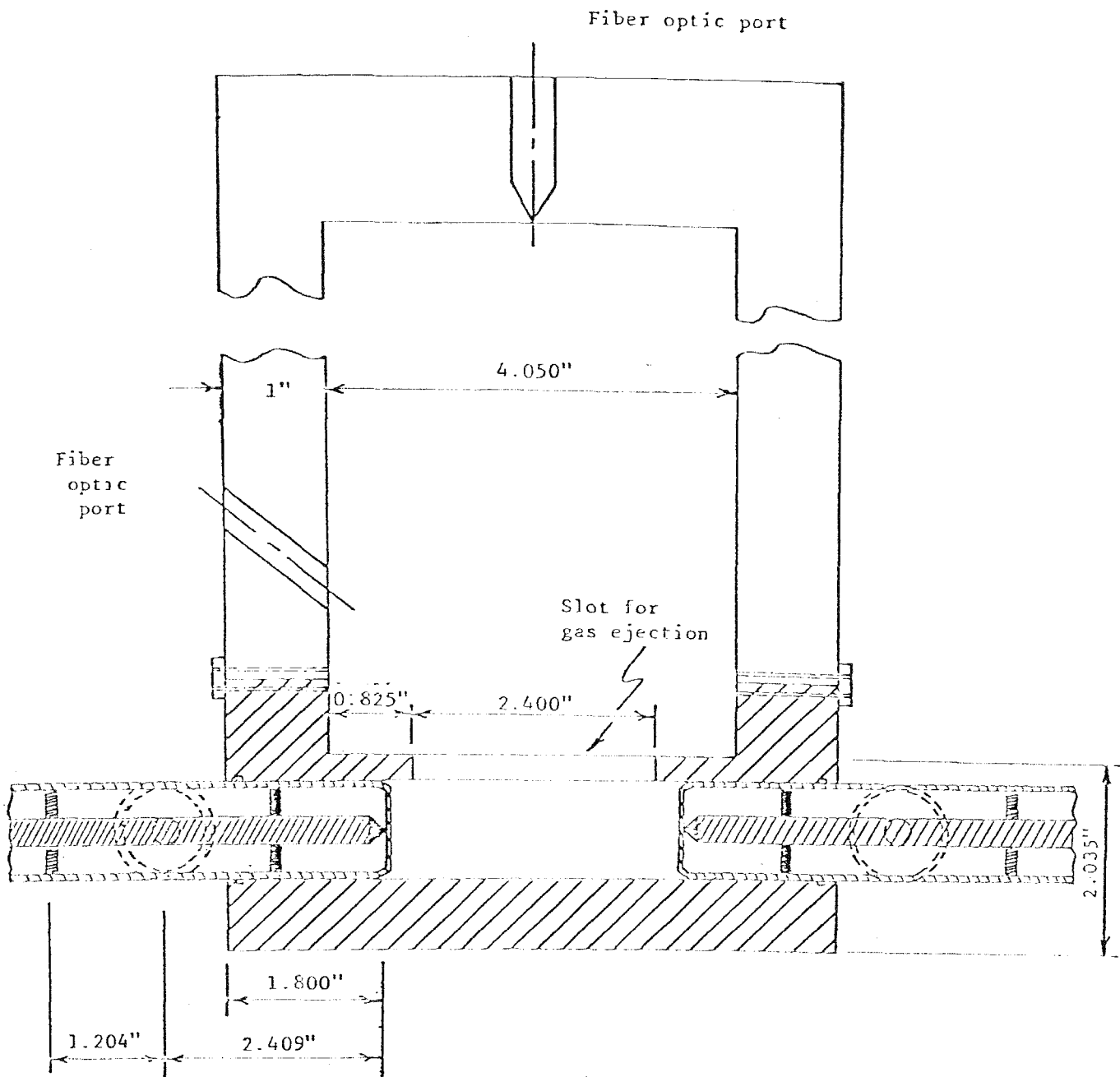

Fig. 1 Electrode Frame with Two Microwave Plasma Torches from Side

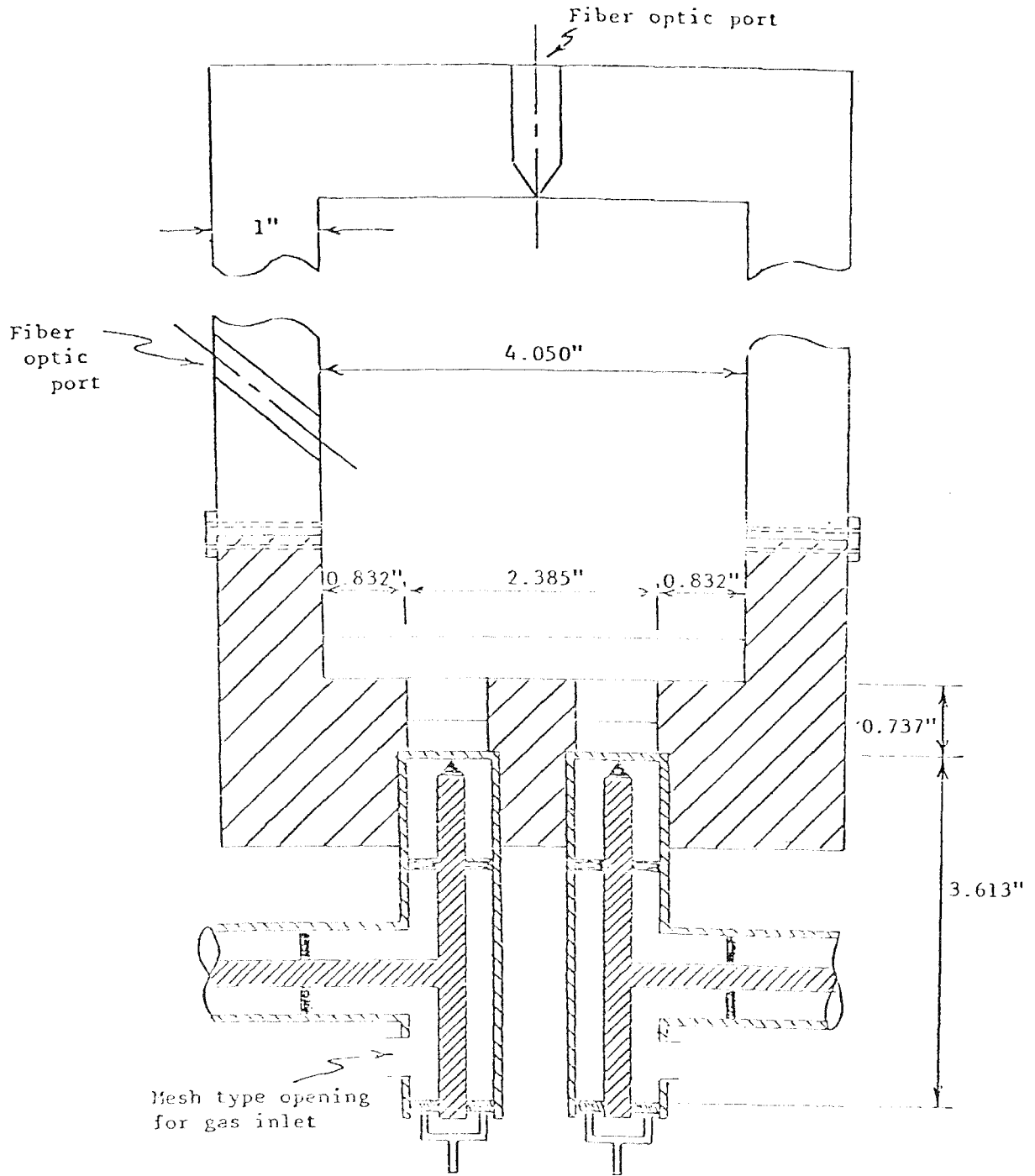

Fig. 2 Electrode Frame with Two Microwave Plasma Torches from Bottom

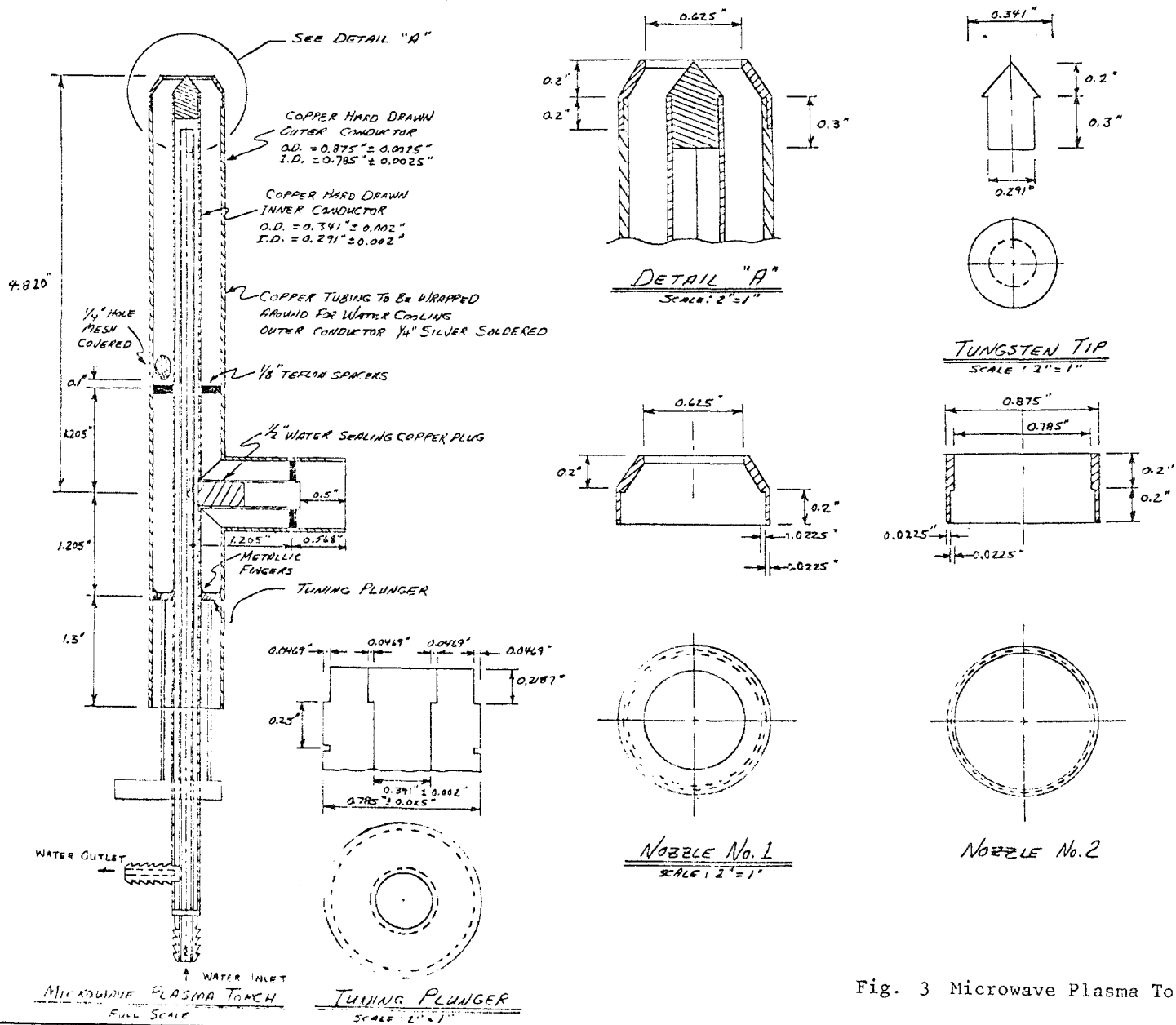
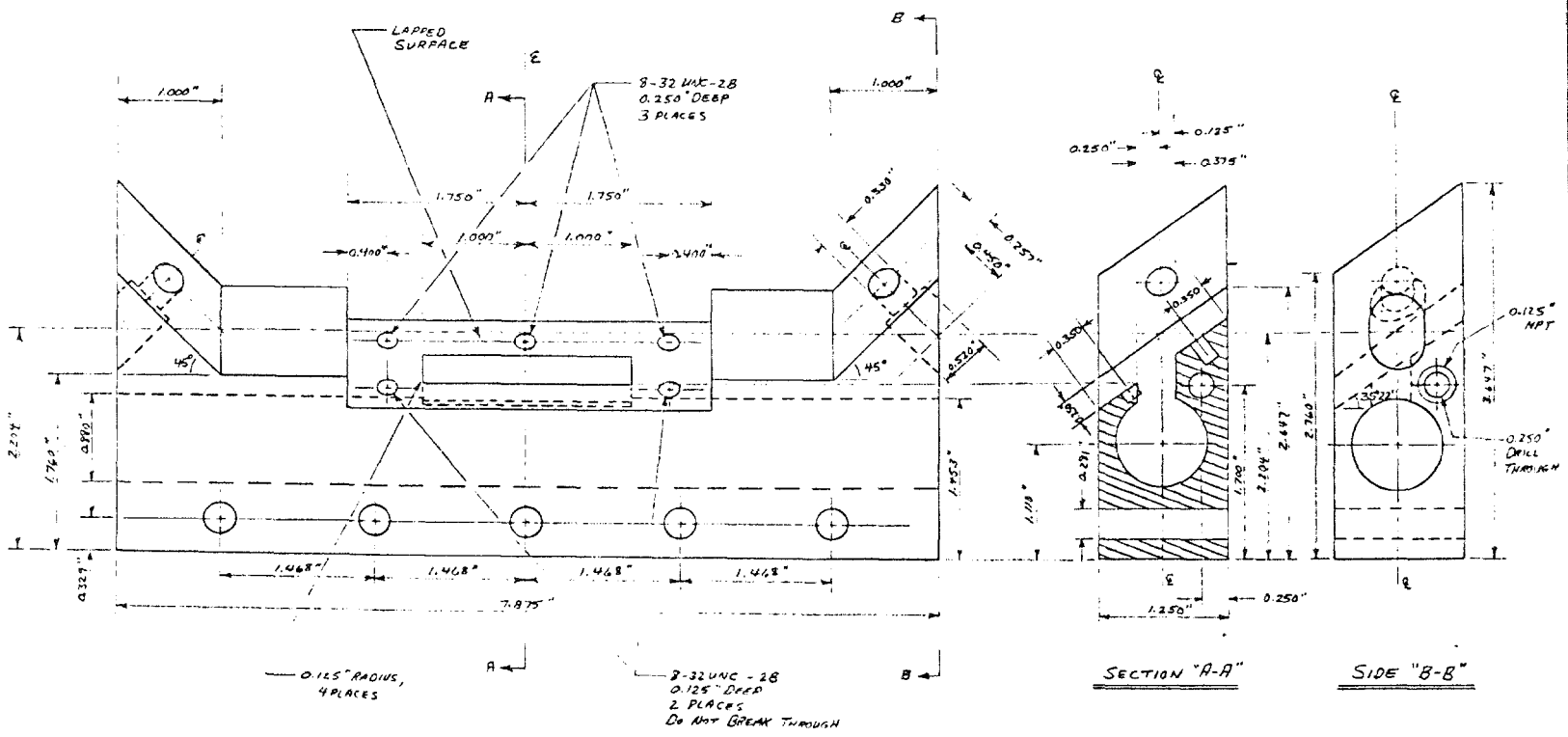

Fig. 3 Microwave Plasma Torch



NOTE:  PART ON SPACER TO BE REMOVED

Fig. 4 Microwave Gaseous Electrode Test Frame Mod I

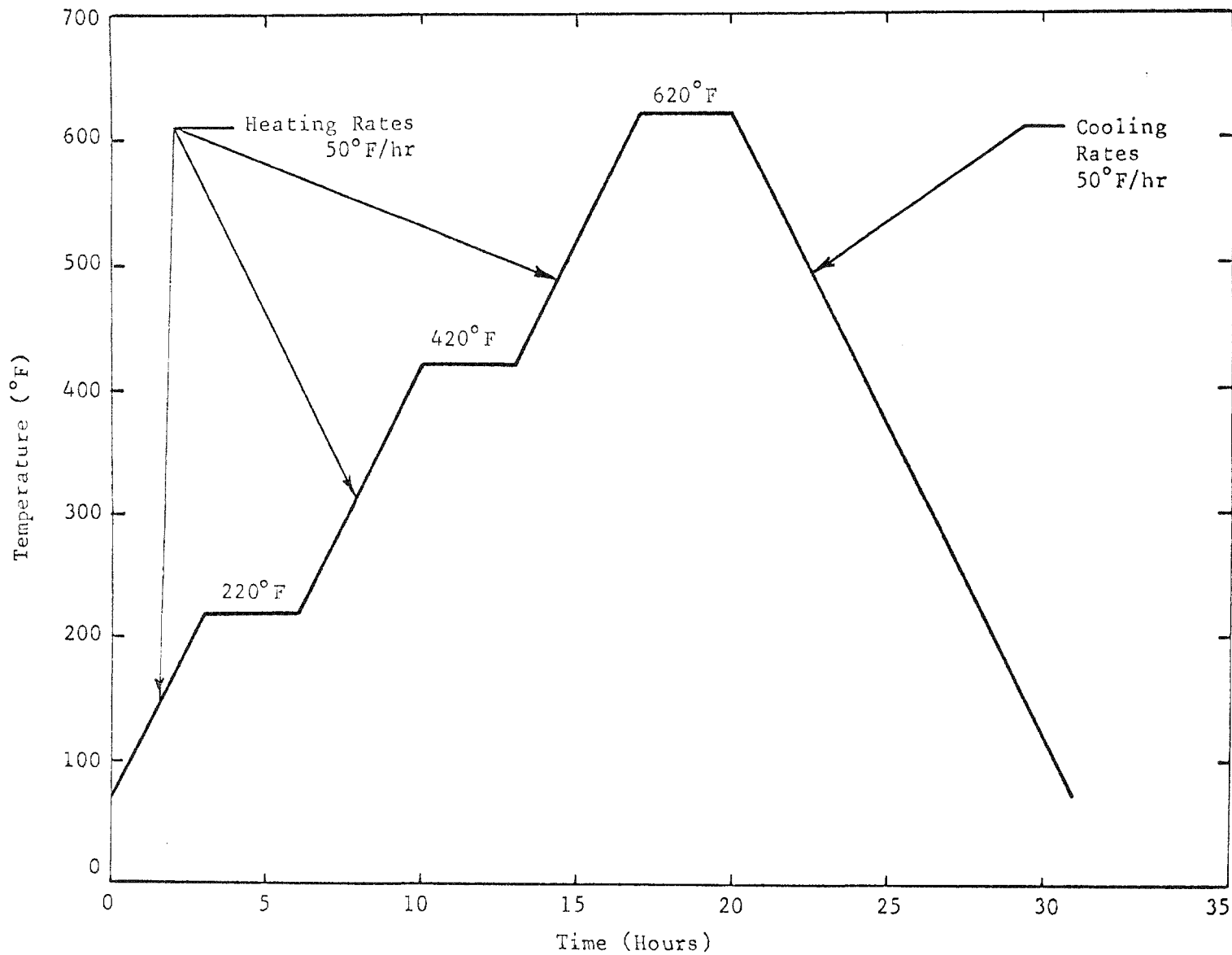

Fig. 5 Heat Treatment for Ceramic Liner  
(Temperature - Time History)

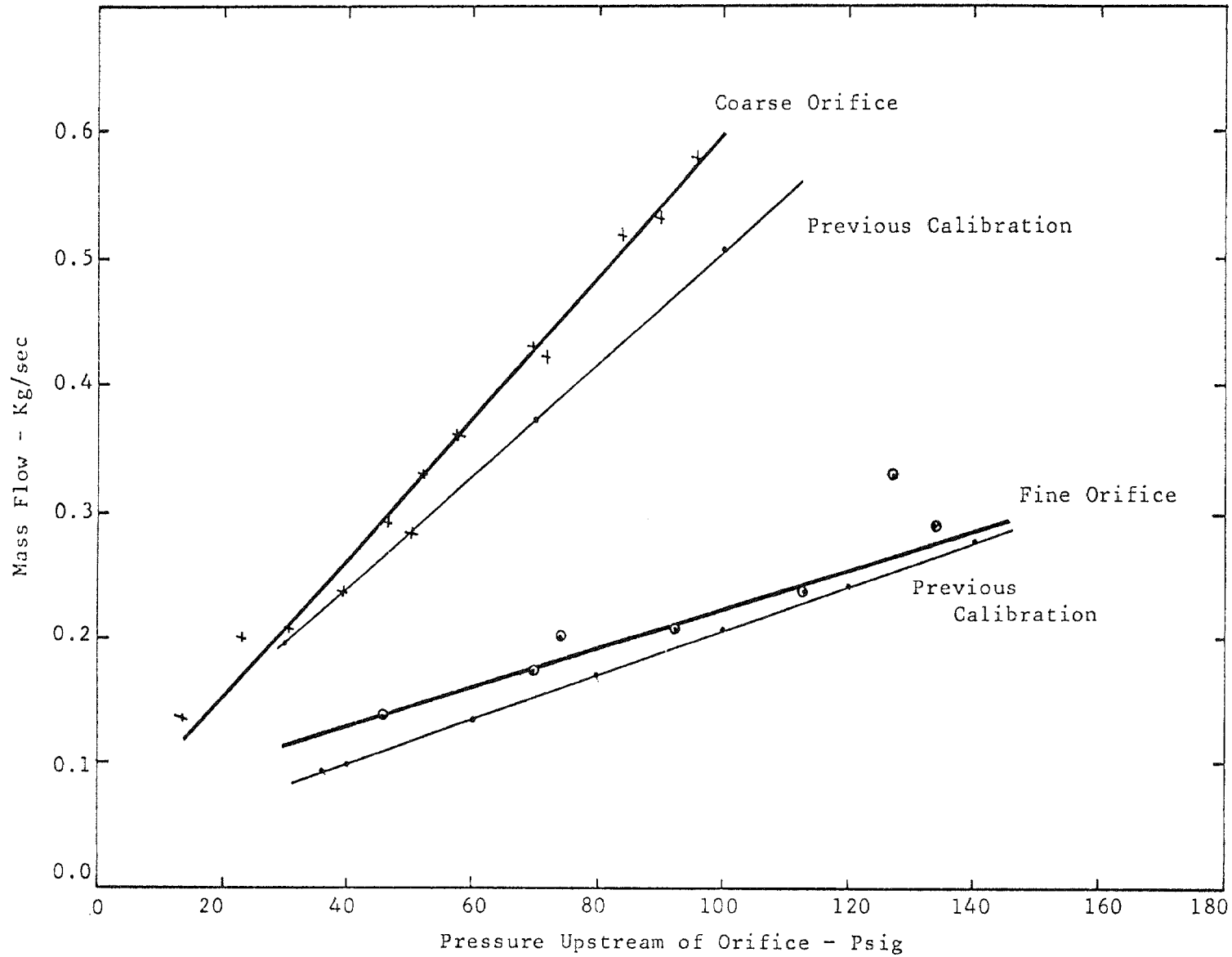

Fig. 6 Oxygen Flow Calibration Using New Flow Meter

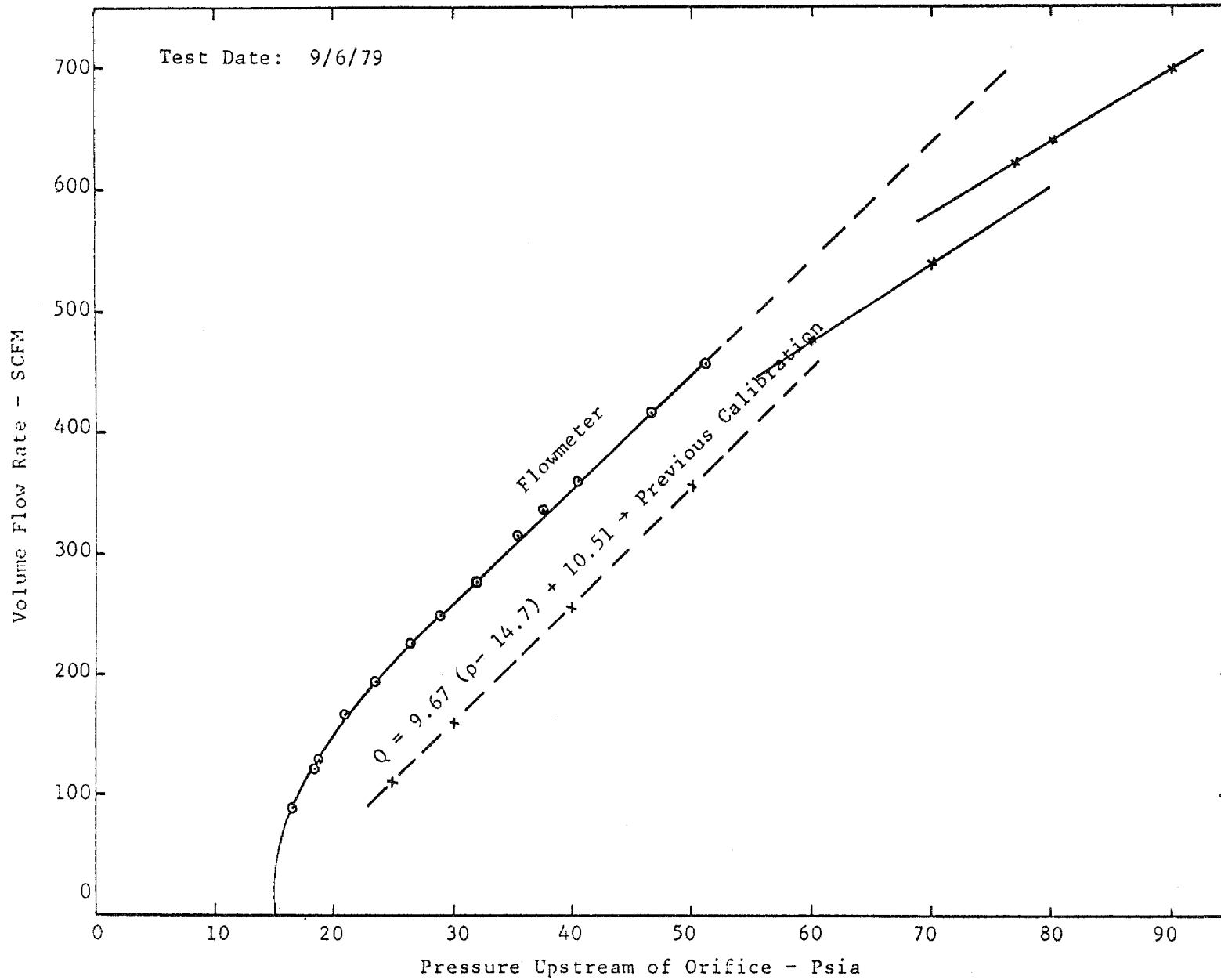

Fig. 7 Nitrogen Flow Calibration Using New Flow Meter

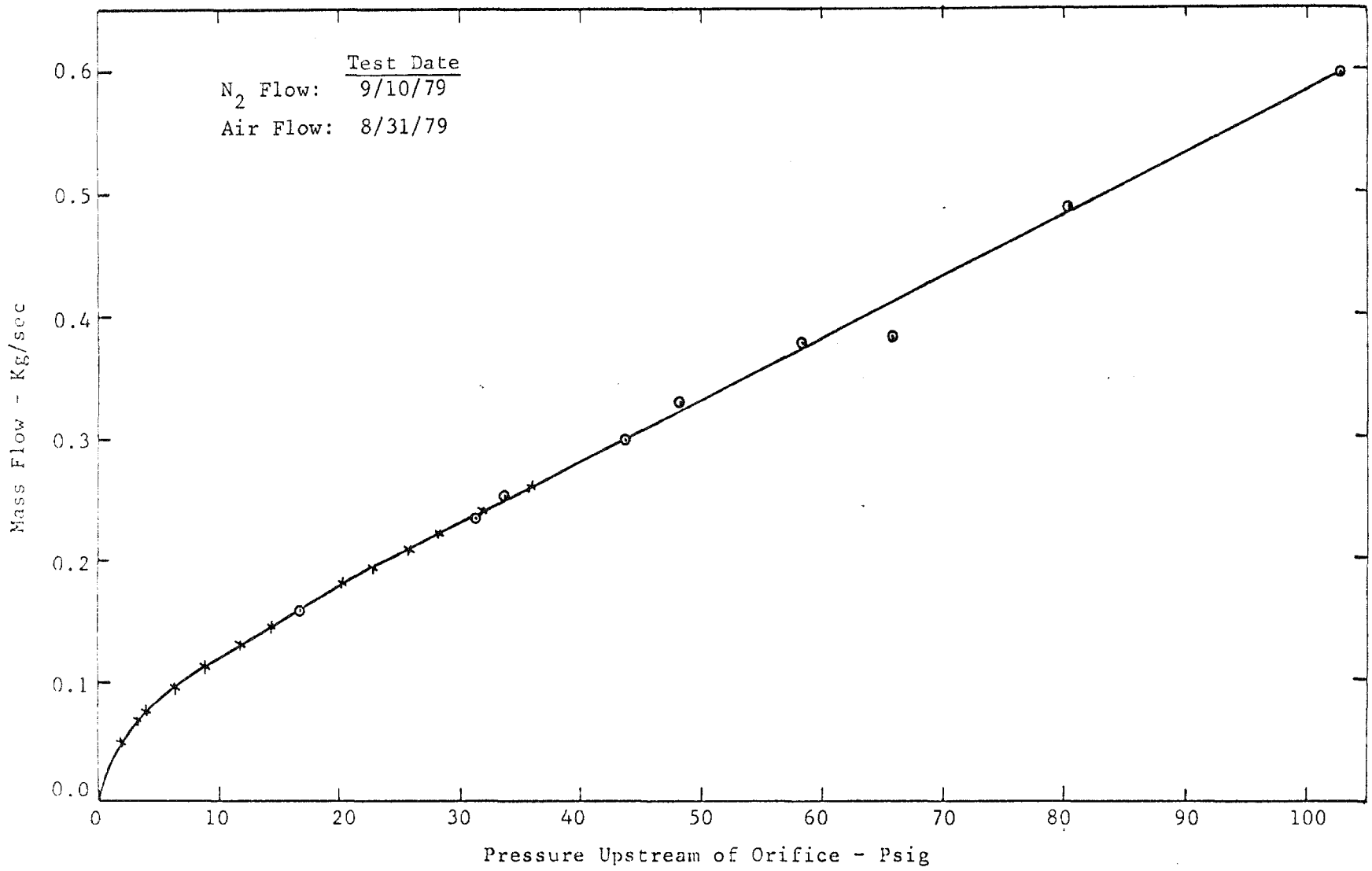

Fig. 8 Air and N<sub>2</sub> Flow Calibration Using New Flow Meter

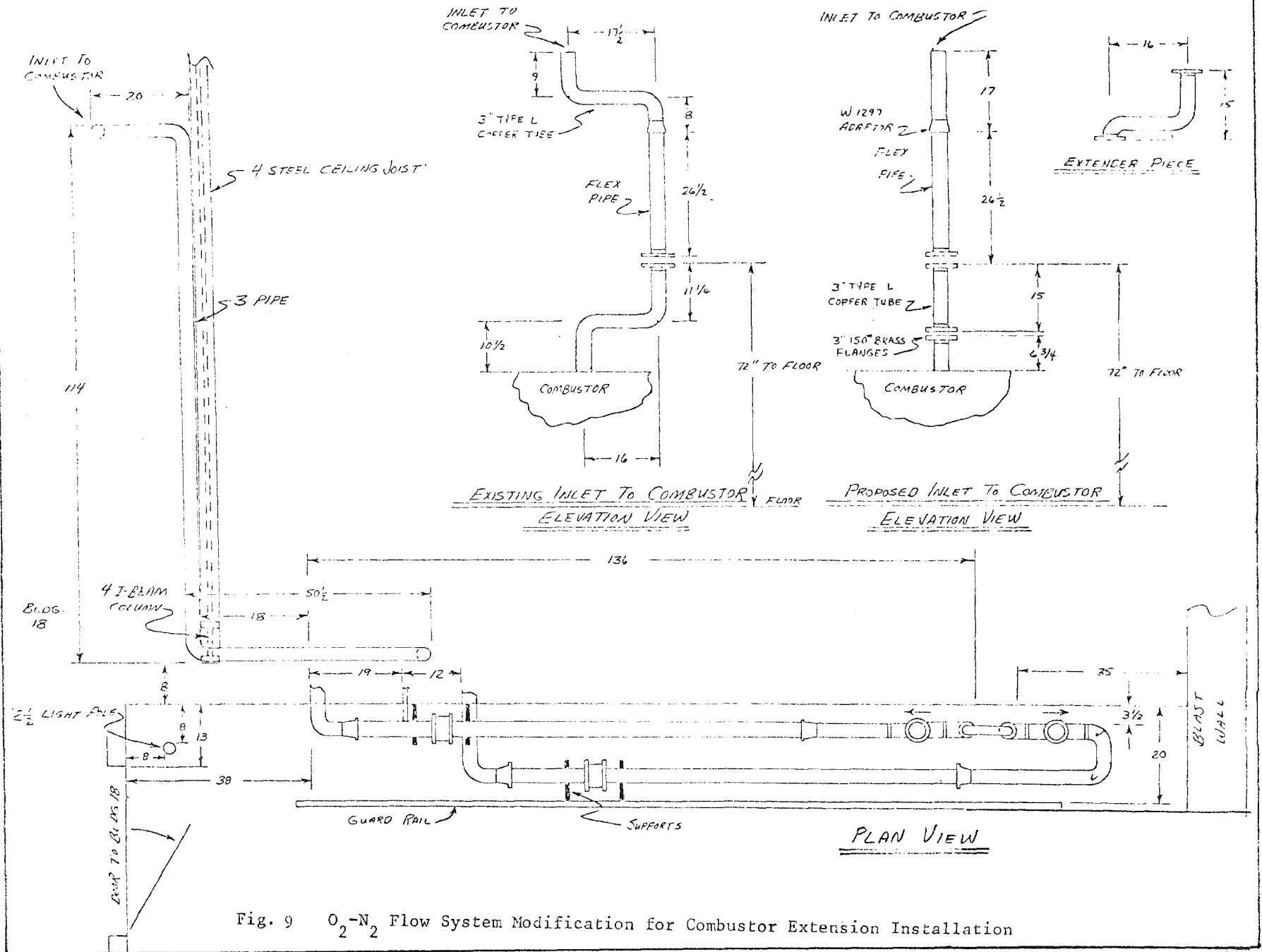

Fig. 9  $O_2-N_2$  Flow System Modification for Combustor Extension Installation

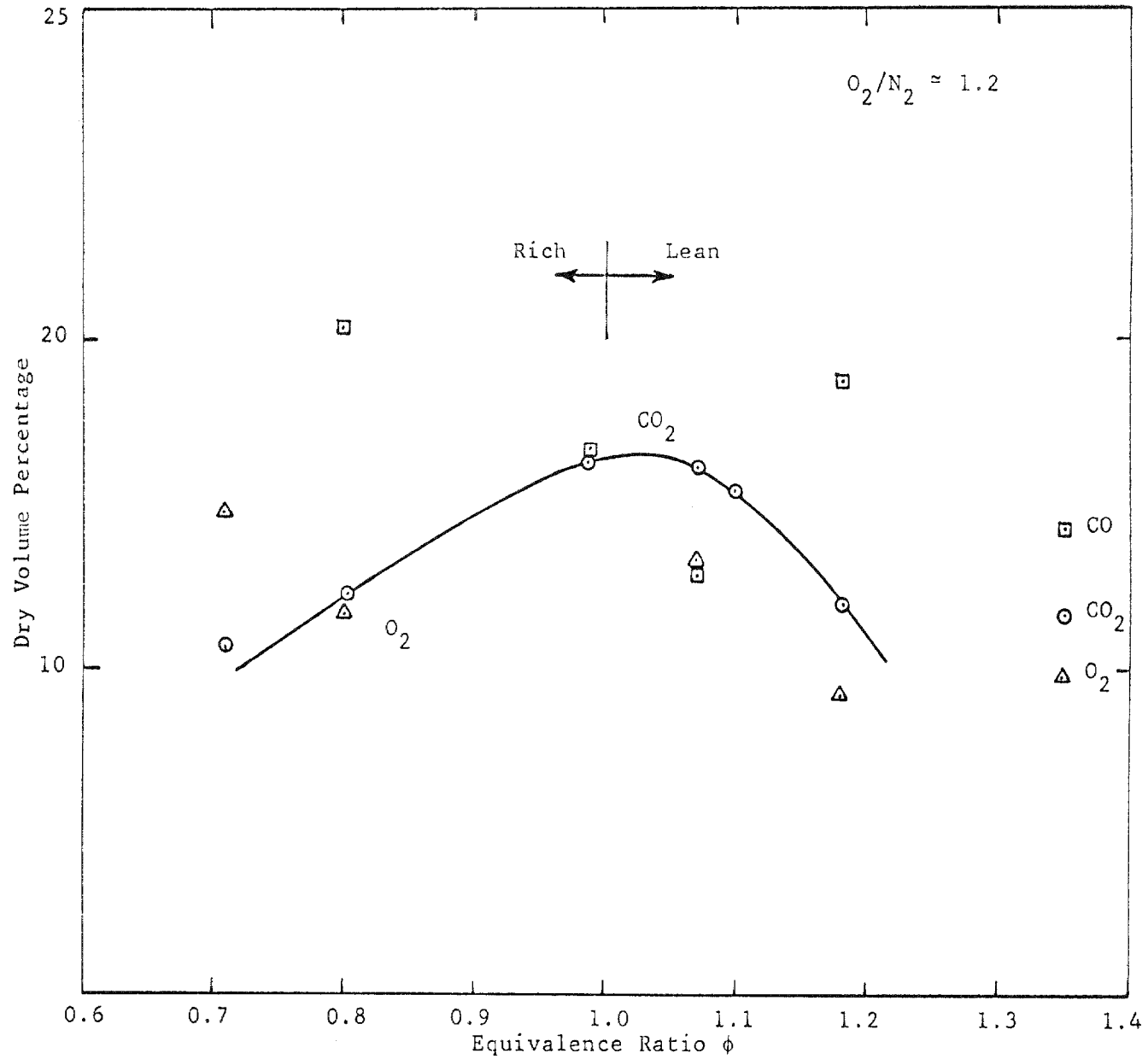

Fig. 10 Gas Composition at Combustor Exit for Various Equivalence Ratios

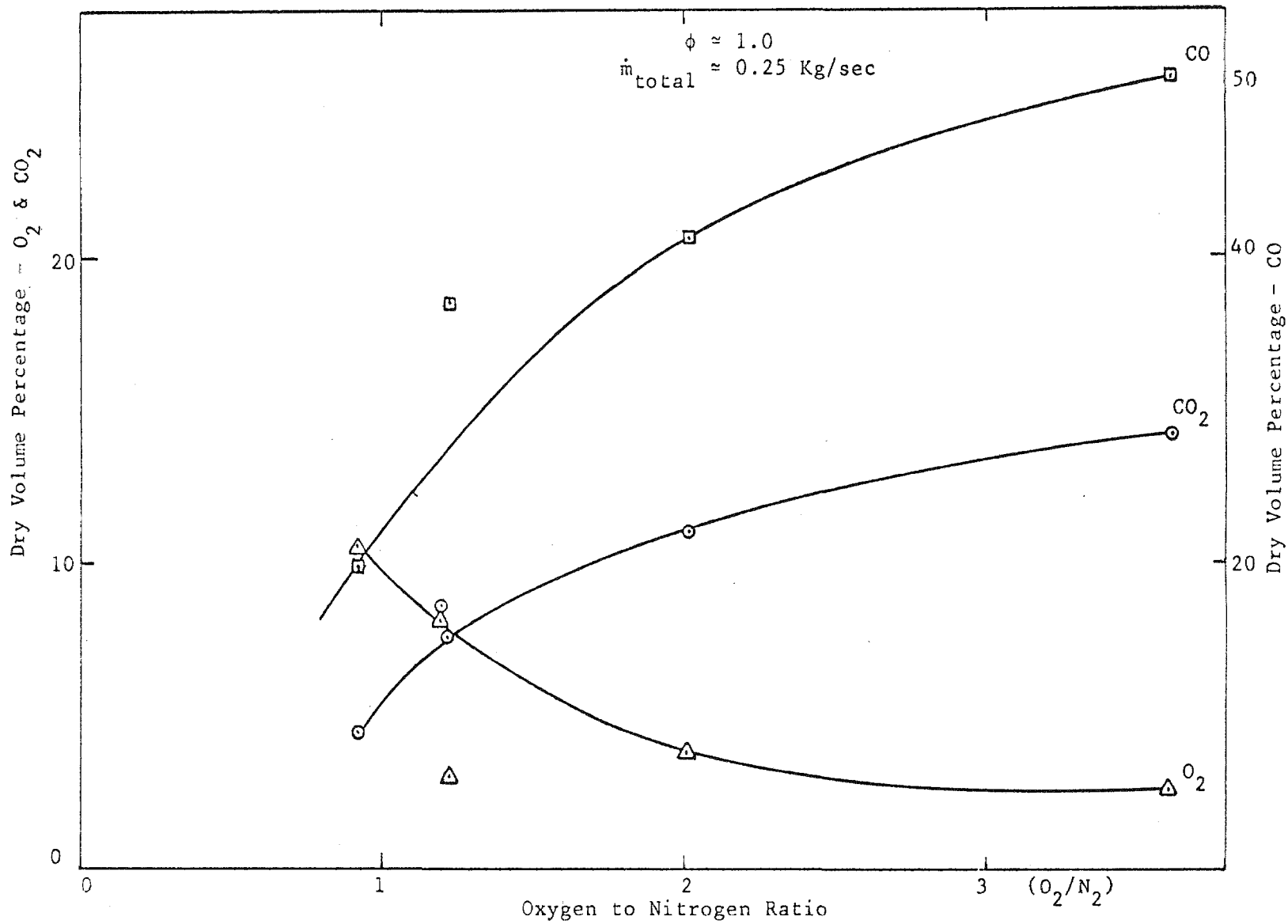

Fig. 11 Gas Composition at Combustor Exit for Various  $O_2/N_2$  Ratios

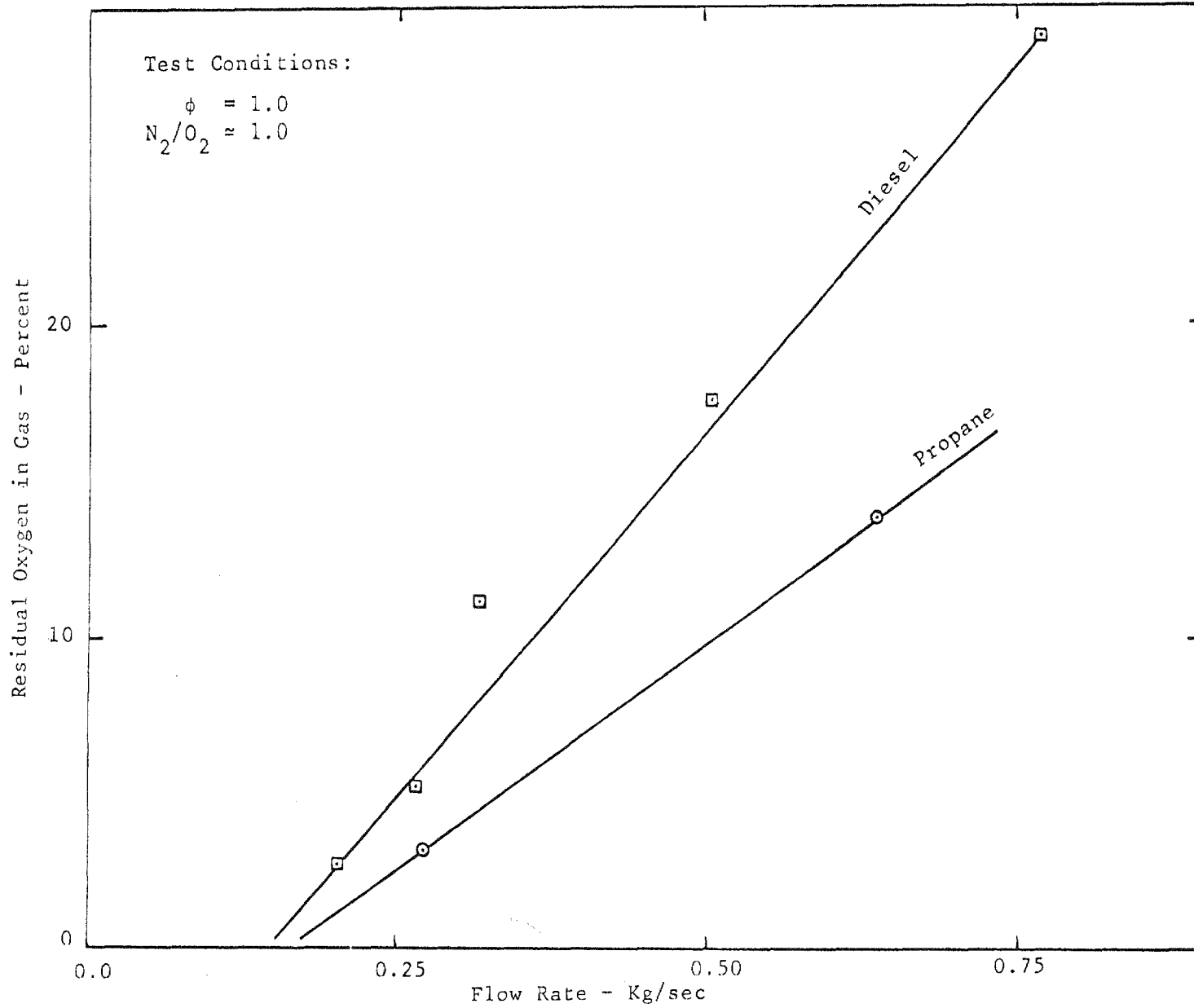

Fig. 12 Variation of Residual Oxygen Present at the Combustor Exit with Gas Flow Rate

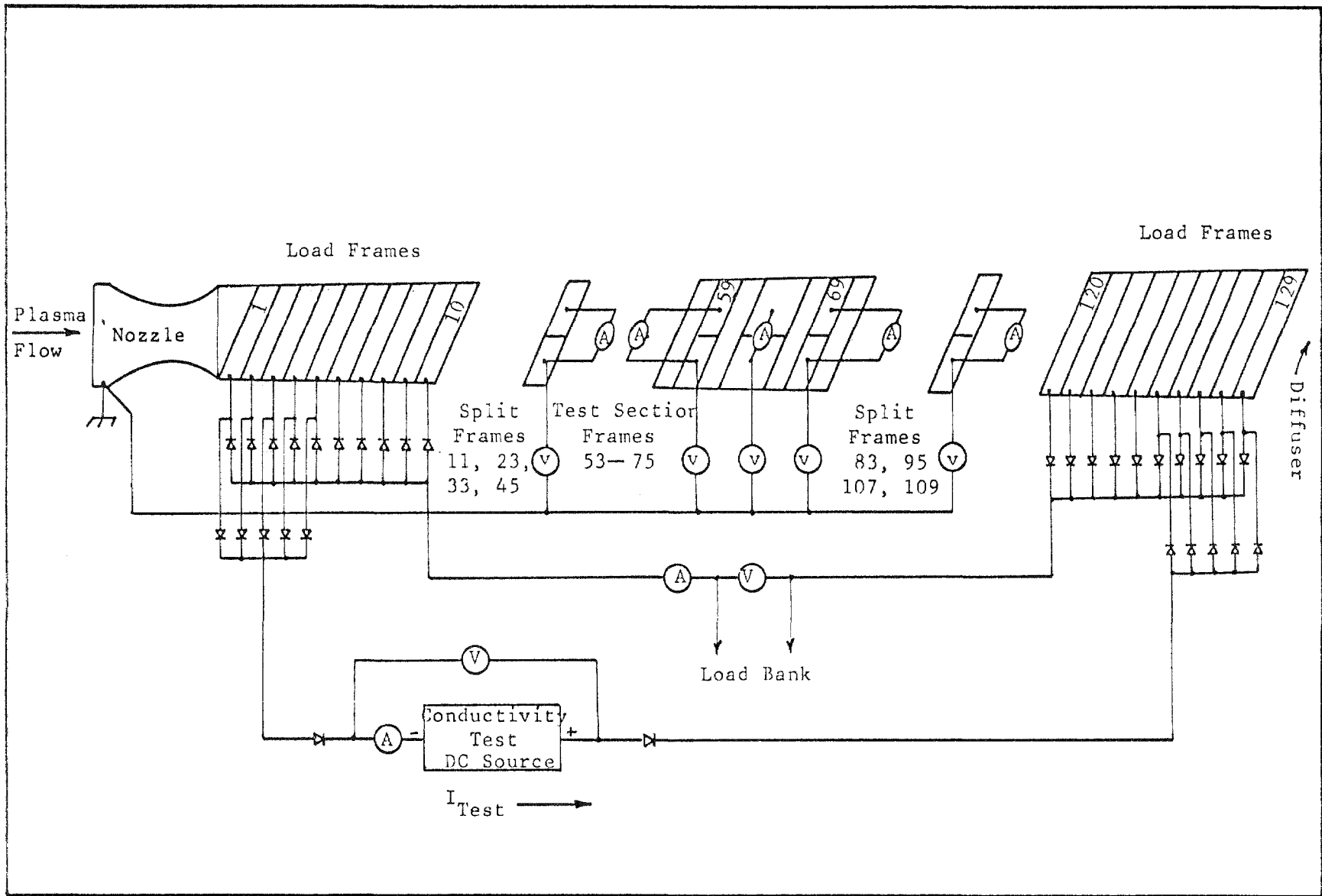

Fig. 13 MHD Channel Test Set-Up for Conductivity Measurements

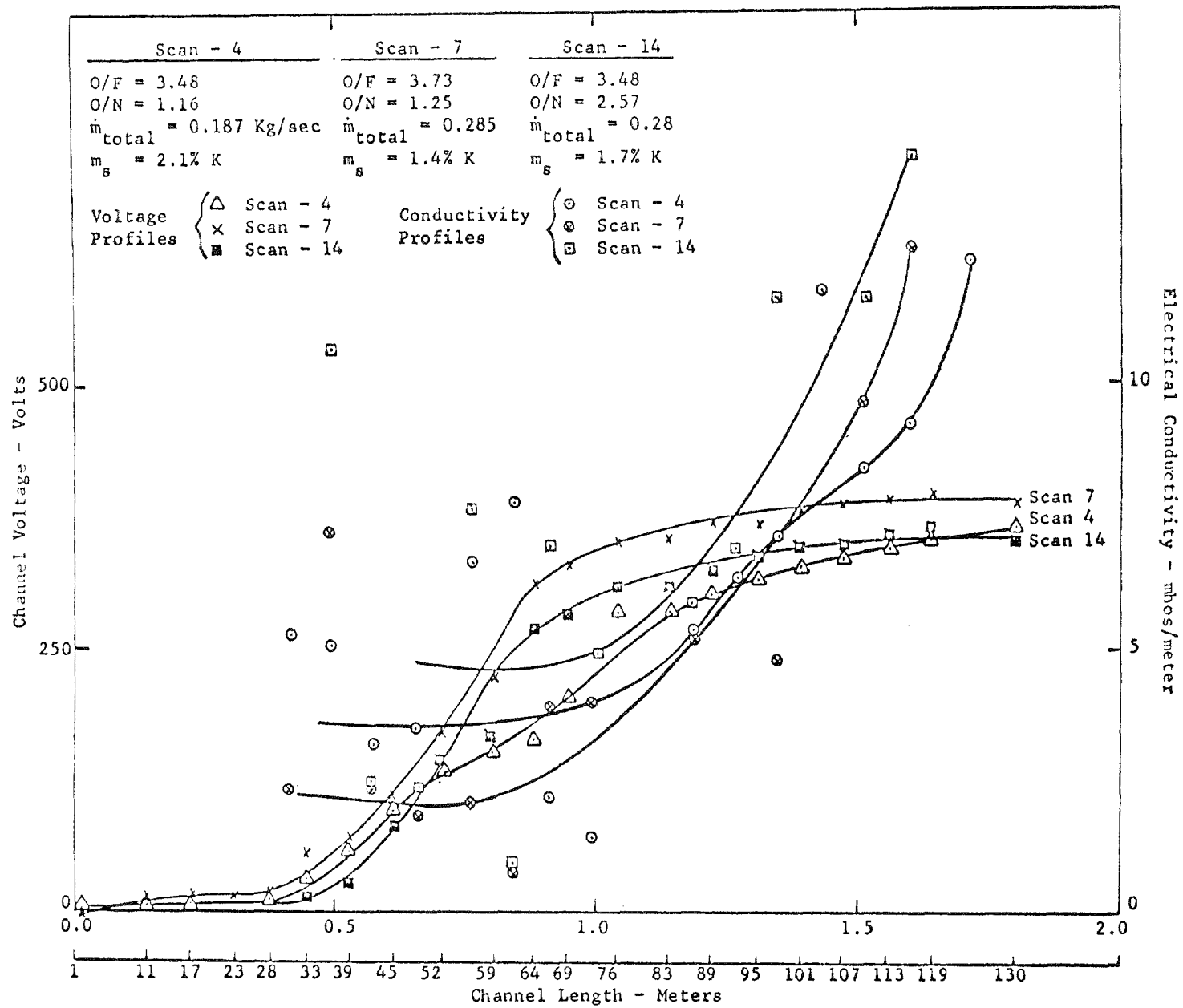

Fig. 14 Voltage Distribution and Plasma Conductivity Profile in the Channel

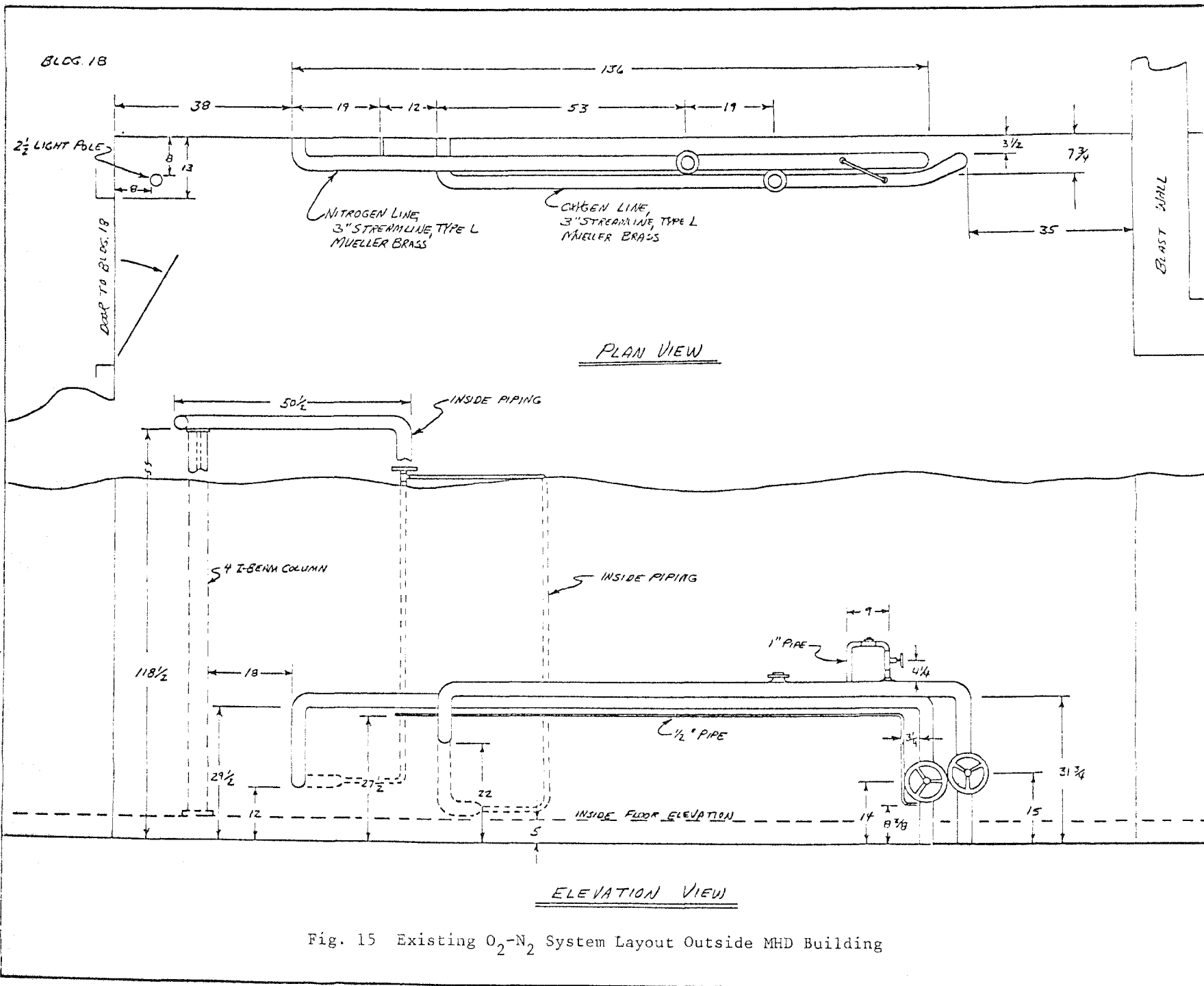

Fig. 15 Existing  $O_2-N_2$  System Layout Outside MHD Building

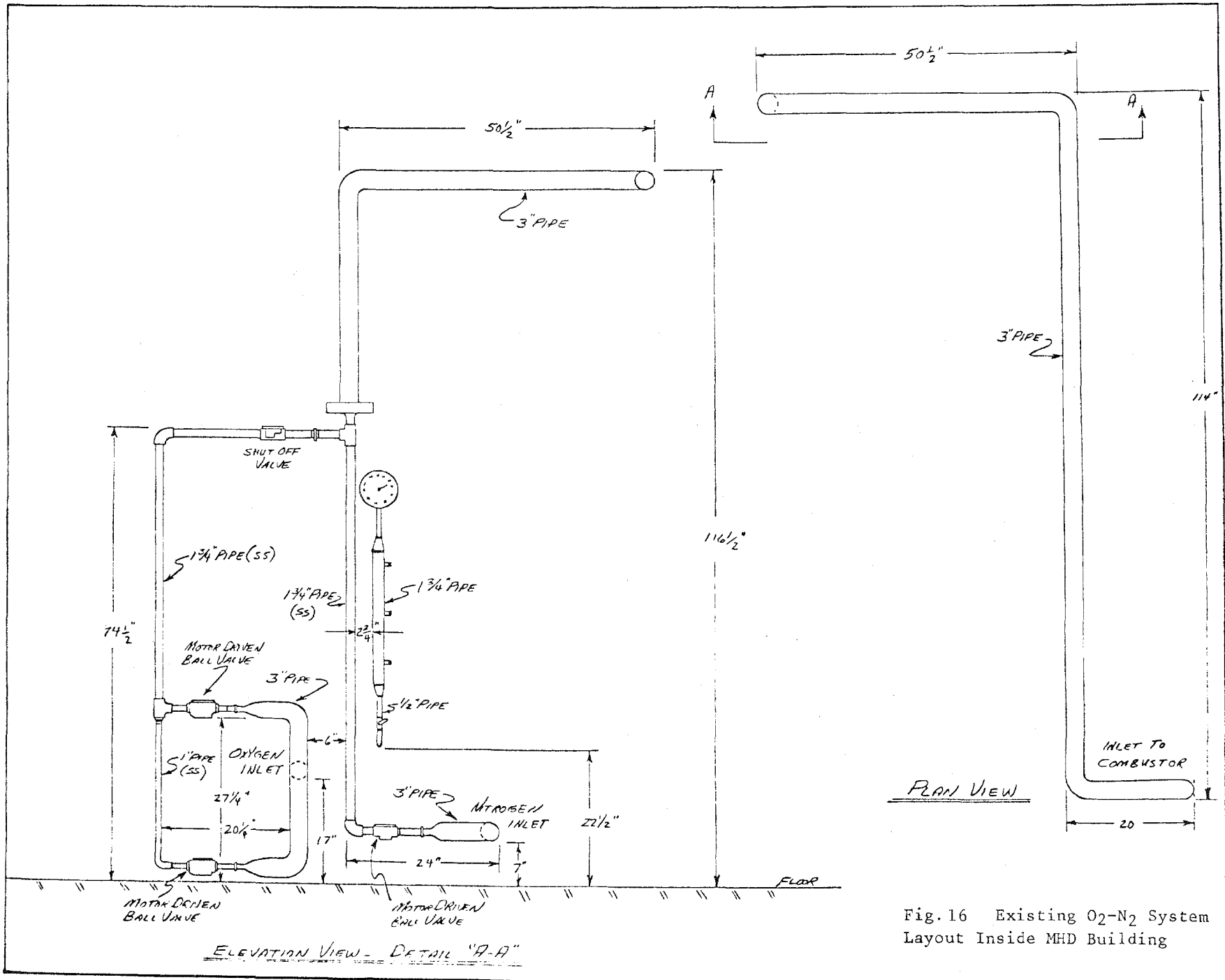

Fig. 16 Existing O<sub>2</sub>-N<sub>2</sub> System Layout Inside MHD Building

BLDG. 14

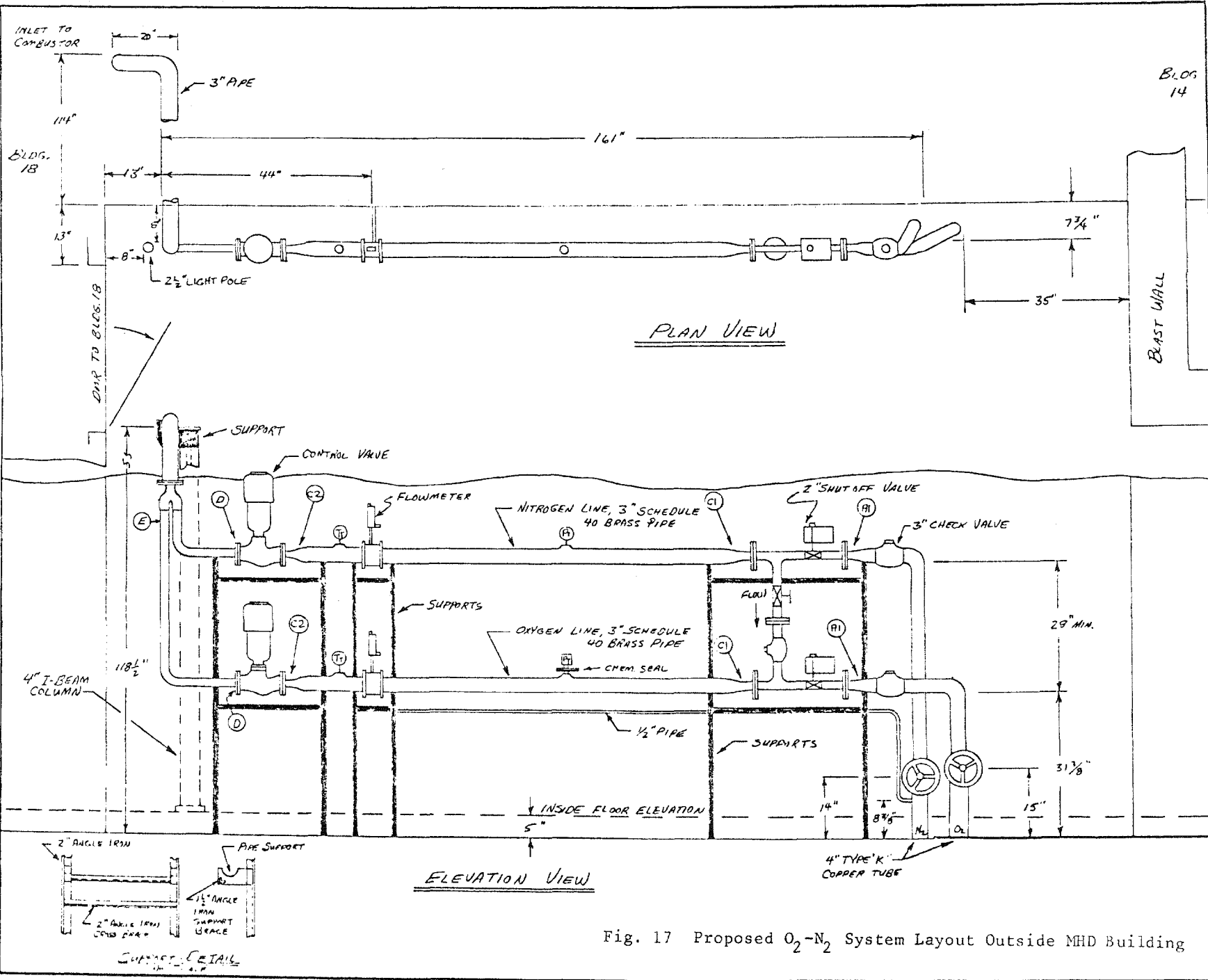

Fig. 17 Proposed O<sub>2</sub>-N<sub>2</sub> System Layout Outside MHD Building

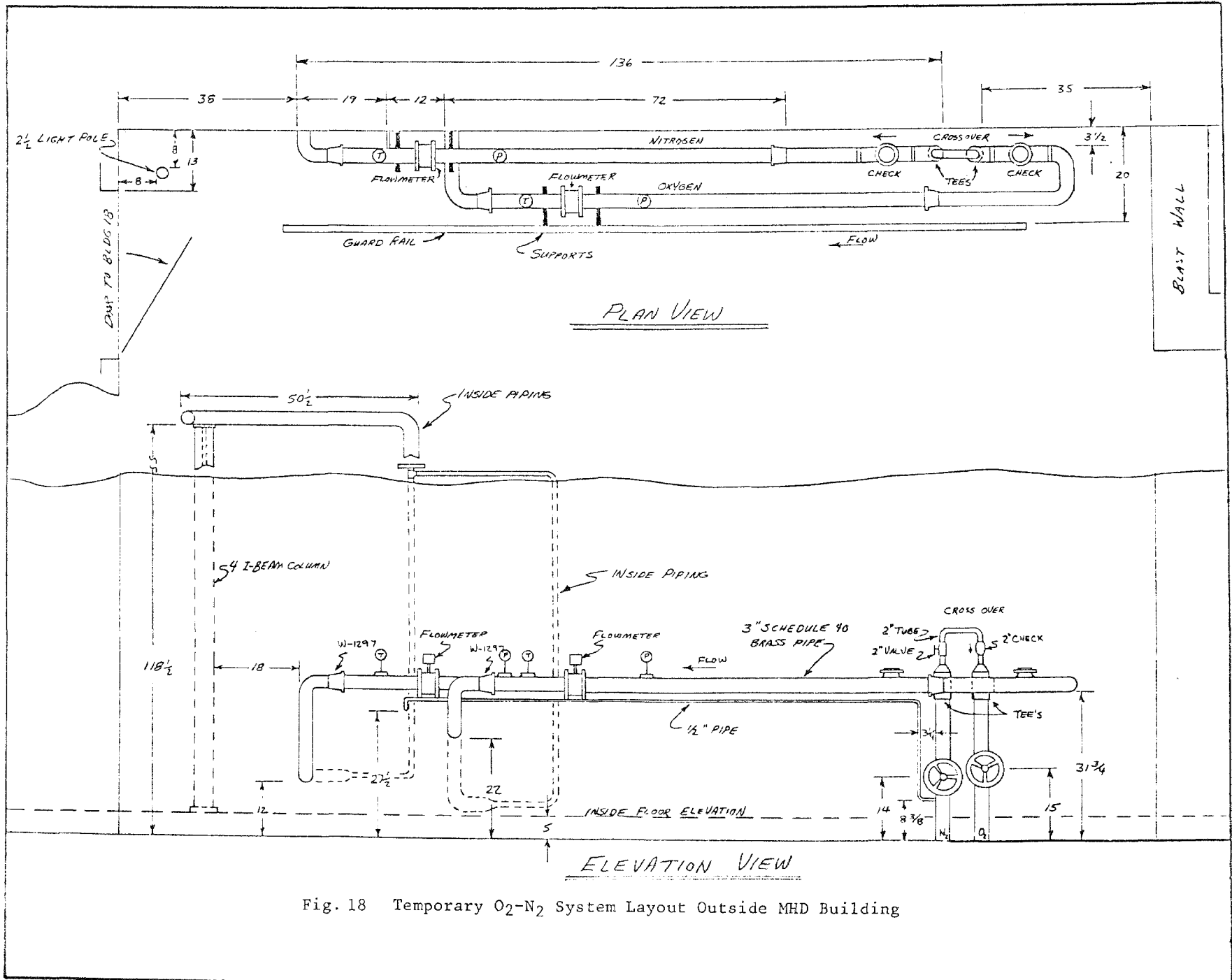

Fig. 18 Temporary O<sub>2</sub>-N<sub>2</sub> System Layout Outside MHD Building