

CONF-9010396--1

LBL-28791



Lawrence Berkeley Laboratory

UNIVERSITY OF CALIFORNIA

APPLIED SCIENCE DIVISION

APPLIED SCIENCE DIVISION

AUG 08 1991

Presented at the 1990 HVAC & Building Systems Congress,
Seattle, WA, October 7-12, 1990, and to be
published in the Proceedings

Thermal Performance Characteristics of Compact Fluorescent Fixtures

M.J. Siminovitch, F.M. Rubinstein, and R.E. Whiteman

March 1990

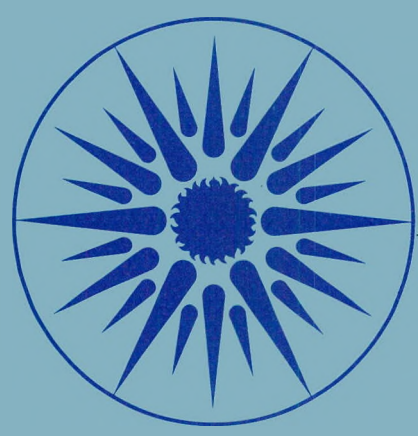

DO NOT MICROFILM
COVER

APPLIED SCIENCE
DIVISION

MASTER

Prepared for the U.S. Department of Energy under Contract Number DE-AC03-76SF00098

DISTRIBUTION OF THIS DOCUMENT IS UNLIMITED

DISCLAIMER

This report was prepared as an account of work sponsored by an agency of the United States Government. Neither the United States Government nor any agency thereof, nor any of their employees, makes any warranty, express or implied, or assumes any legal liability or responsibility for the accuracy, completeness, or usefulness of any information, apparatus, product, or process disclosed, or represents that its use would not infringe privately owned rights. Reference herein to any specific commercial product, process, or service by trade name, trademark, manufacturer, or otherwise does not necessarily constitute or imply its endorsement, recommendation, or favoring by the United States Government or any agency thereof. The views and opinions of authors expressed herein do not necessarily state or reflect those of the United States Government or any agency thereof.

DISCLAIMER

Portions of this document may be illegible in electronic image products. Images are produced from the best available original document.

DISCLAIMER

This document was prepared as an account of work sponsored by the United States Government. Neither the United States Government nor any agency thereof, nor The Regents of the University of California, nor any of their employees, makes any warranty, express or implied, or assumes any legal liability or responsibility for the accuracy, completeness, or usefulness of any information, apparatus, product, or process disclosed, or represents that its use would not infringe privately owned rights. Reference herein to any specific commercial product, process, or service by its trade name, trademark, manufacturer, or otherwise, does not necessarily constitute or imply its endorsement, recommendation, or favoring by the United States Government or any agency thereof, or The Regents of the University of California. The views and opinions of authors expressed herein do not necessarily state or reflect those of the United States Government or any agency thereof or The Regents of the University of California and shall not be used for advertising or product endorsement purposes.

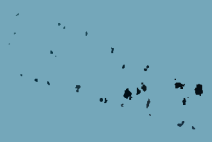

Lawrence Berkeley Laboratory is an equal opportunity employer.

THERMAL PERFORMANCE CHARACTERISTICS OF COMPACT FLUORESCENT FIXTURES

Michael J. Siminovitch, Francis M. Rubinstein and Richard E. Whiteman

Lighting Systems Research Group
Applied Science Division
Lawrence Berkeley Laboratory
Berkeley, California 94720, United States

March 1990

MASTER

This work was supported by the Assistant Secretary for Conservation and Renewable Energy, Office of Building Technologies, Building Equipment Division of the U.S. Department of Energy under Contract No. DE-ACO3-76SFOOO98.

Thermal Performance Characteristics of Compact Fluorescent Fixtures

Michael Siminovitch, Francis Rubinstein and Richard Whiteman

Lighting Systems Research Group
Applied Science Division
Lawrence Berkeley Laboratory
Berkeley, California 94720, United States

Abstract

This paper describes the thermal and light output performance variations for some representative compact fluorescent fixtures. Experimental data is presented showing the changes in relative light output and temperature for both screw-in and dedicated compact fluorescent fixture systems. Initial experimental data shows that substantial losses in fixture efficiency can occur in compact fluorescent fixtures due to elevated temperature conditions inside the lamp compartment. These elevated temperatures affect the minimum lamp wall temperature of the compact fluorescent lamp and the corresponding light output and efficacy characteristics of the lamp ballast system. This paper also presents experimental data on various methods to reduce compartment and lamp wall temperatures in order to increase fixture efficiency.

Introduction

Compact fluorescent lamps are rapidly gaining acceptance for the lighting of commercial interiors. These new sources are finding application in two principal areas: as replacements for incandescent fixtures in existing buildings, and in dedicated fixtures for both new construction and major renovation lighting projects. Using compact fluorescent lamps in existing buildings typically involves removing an existing incandescent lamp and replacing it with a screw-in compact fluorescent fixture. These fixtures include the ballast and are equipped with Edison bases so that they can be screwed into the socket of the existing fixture. These products may include an integral reflector to improve the efficiency of the fixture. The primary motivation for using the screw-in compact fluorescent fixtures is as a retrofit measure to reduce lighting loads by replacing an inefficient source with an inherently more efficacious one.

The second application area for the compact fluorescent lamp is in dedicated fixtures for new construction and major renovation. In general these new compact sources are being used in fixture applications that have been traditionally incandescent. These fixtures are generally of small size and are often recessed mounted. Maintaining high fixture efficiency in a small

fixture requires a small source. In this regard, compact fluorescent lamps are at a disadvantage compared to the less efficient incandescent lamps. First of all, even frosted incandescent lamps have a smaller light-emitting surface area than a compact fluorescent source of equivalent lumen output. This difference in surface area combined with the fact that compact fluorescent lamps are of linear shape, increases the difficulty of designing a reflector that will allow the light from the source to efficiently leave a small fixture. Secondly, the light output and efficacy of all fluorescent lamps, including the compact fluorescents, are highly sensitive to changes in ambient temperature. The functional relationship between light output, efficacy and lamp wall temperature for standard T12 40 watt lamps has been studied previously and shows a 15-20% decrease in light output in standard three- and four-lamp luminaires. Operating a compact fluorescent source inside a small fixture presents an even greater thermal problem due to the small fixture surface area and constricted thermal or sealed thermal environment that reduces convective transfer. Figure 1 plots the ratio of lamp power to the surface area of the fixture enclosure for both standard 2x4 fixtures and a number of compact fixtures. For a standard 2x4 enclosed recessed troffer the loading per surface area of fixture is in the range of 6 to 8 watts per square foot. For the compact fixture this power density or loading is in the range of 20-40 watts per square foot. This indicates that the lumen reduction and decrease in system efficacy associated with operating fluorescents at elevated temperatures is at least as significant for compact fluorescent fixtures as it is for the standard T12 systems.

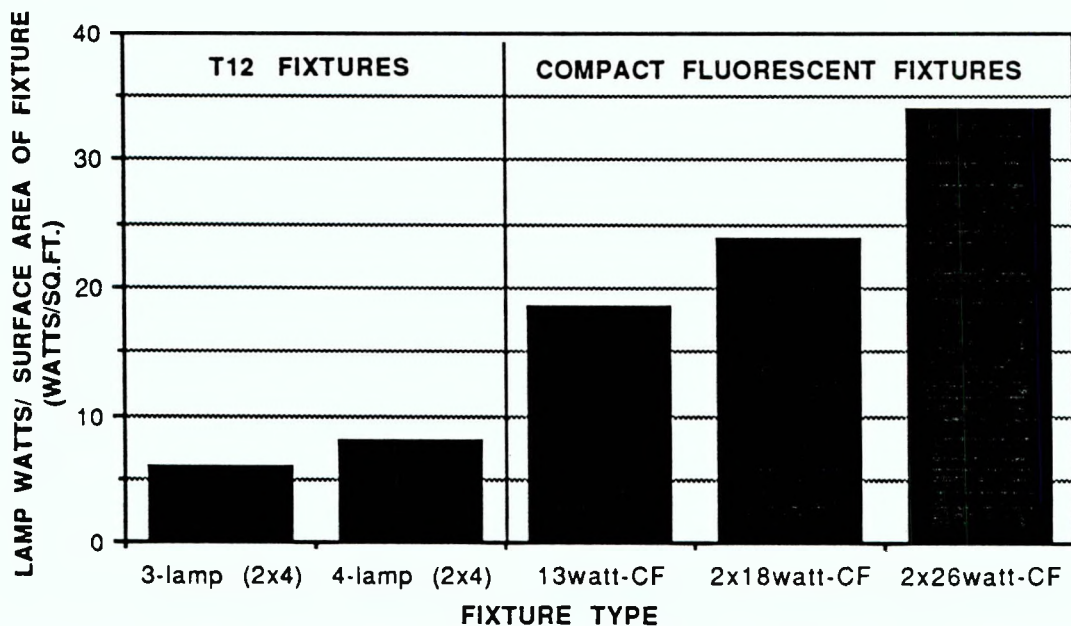

Figure 1. Lamp power per surface area for typical 2x4 and compact fluorescent fixtures.

This paper presents the results of a series of tests designed to identify the range of thermally-induced light losses that occur in compact fluorescent fixtures. In addition, two methods for improving the thermal performance of these fixtures are explored.

Methodology

A series of commercially available compact fluorescent systems were tested measuring both changes in light output and temperature. Two classes of fixture systems were examined in this initial phase: 1) a screw-in compact fluorescent fixture designed as a retrofit for incandescent fixtures and 2) a dedicated compact fluorescent fixture for use in new construction.

An experimental test station (Figure 2) was constructed to simulate the enclosure and mounting conditions for a standard ceiling configuration. The temperature of the lamps, compartment and ambient environment were monitored with thermistors tied a data acquisition system. Changes in relative light output were monitored with a photometer mounted directly under the fixture system. All experiments were conducted in a 20°C temperature controlled space.

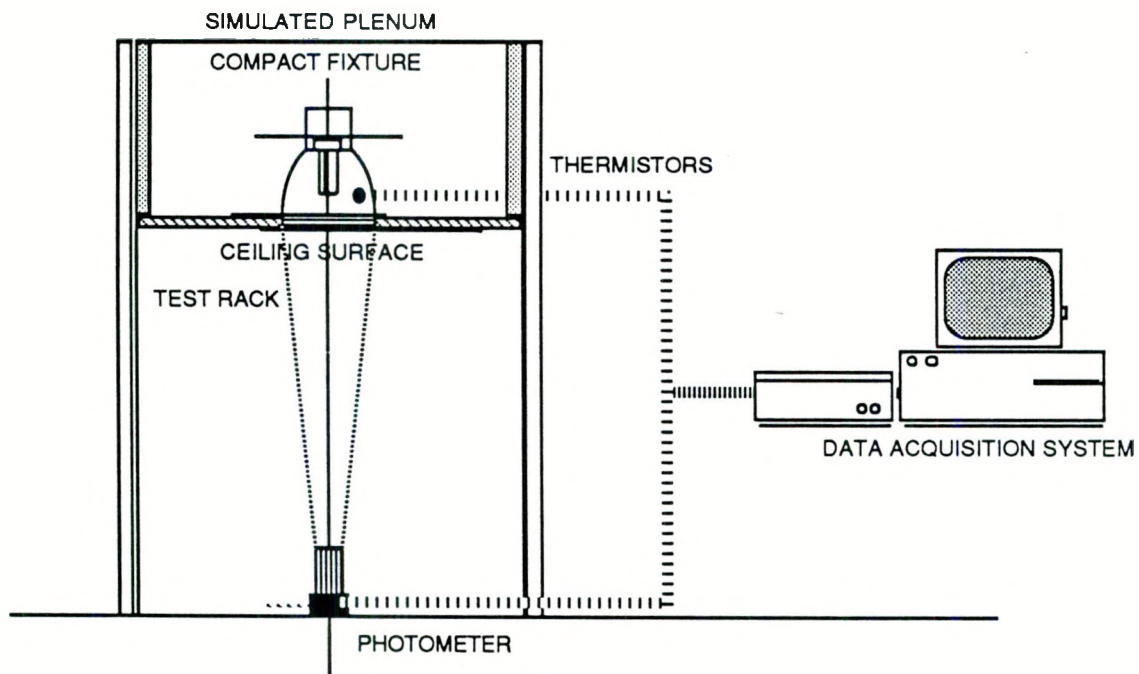

Figure 2. Experimental test station.

Each lamp, ballast and fixture configuration was initially stabilized by running the lamps for approximately 24 hours. This was done in order to assure establishment of a mercury cold spot. The fixture was then switched off and allowed to reach equilibrium with the 20°C ambient temperature. The fixture was then re-energized while monitoring temperature and light

output. Light output readings were scaled relative to the maximum light measurement obtained. Thus, when the fixture is first re-energized, relative output is less than 100% because the minimum lamp wall temperature (MLWT) is lower than the optimum (~36°C). As the lamp heats, the MLWT will pass through the optimum value. The light reading obtained at this temperature was taken to be 100% relative light output (RLO). As the lamp heat further, RLO drops steadily from 100%. The 100% RLO is usually achieved 5 to 10 minutes after energizing the fixture. Thermal equilibrium is usually achieved after one to four hours of operation depending upon the volume and mass of the fixture.

Results

A 13 watt screw-in compact fixture with an integral lens and reflector was tested in three configurations: in free air at 20°C, in a recessed ceiling-mounted fixture, and in a ceiling-mounted fixture with an externally-located heat sink. Figure 3 shows a schematic of the screw-in fixture as mounted within the recessed fixture.

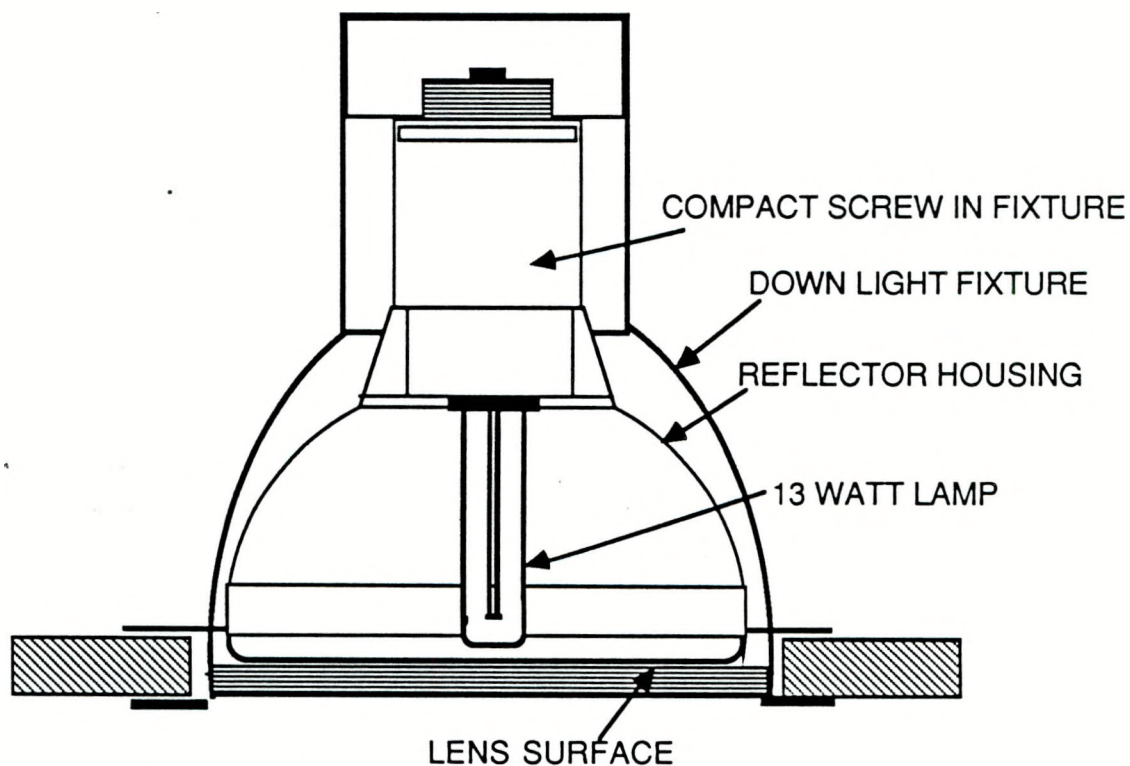

Figure 3. Compact 13 watt fluorescent fixture inside recessed fixture.

Figure 4 shows the changes in relative light output as a function of time for the screw-in 13 watt compact fluorescent fixture operating in free air and within the recessed fixture. Maximum relative light output is achieved shortly after the fixture is energized (5-10 minutes). After this the light

output starts to drop from its maximum value for both the free air and fixture integrated system. At equilibrium, the fixture operated in free air loses approximately 16% of its light output due to thermal conditions within the lamp compartment. The same fixture inside a recessed downlight loses approximately 20% at equilibrium.

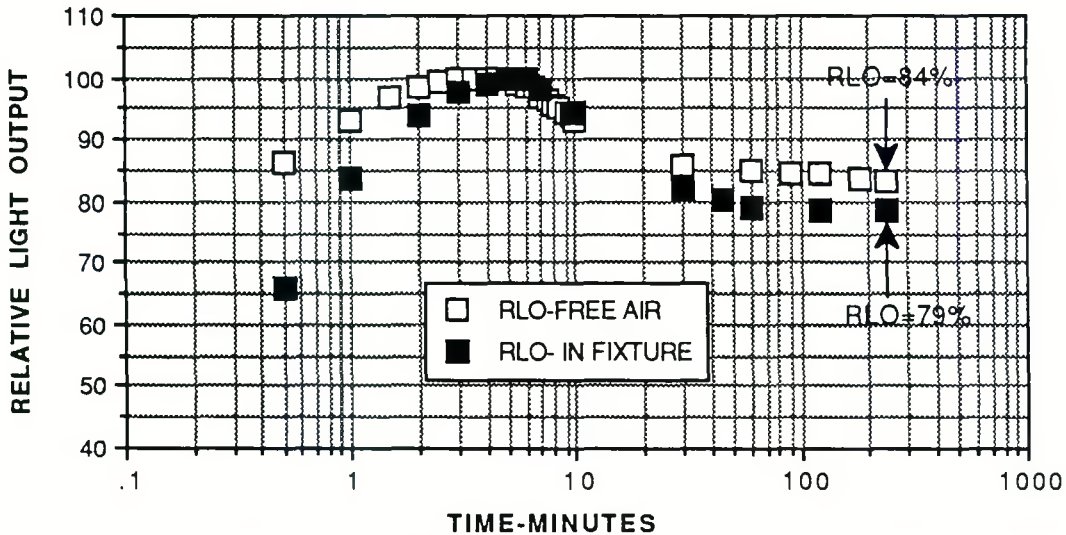

Figure 4. Relative light output for 13 watt fluorescent fixture.

The same screw-in fixture was modified with a small heat sink attachment in order to cool the lamp wall temperature inside the fixture. Figure 5 shows a plan and cross section of the heat sink system. This heat sink was made up of three metal vanes radially projecting from a center rod. This rod was thermally bonded to the ends of the lamp at the naturally occurring mercury cold spot. The rod conducts heat from the lamps through a small 1/2 inch hole directly under the elbows of the lamp to the radial cooling vanes. Figure 6 shows the relative light output for the screw-in fixture inside a downlight fixture operating with and without the heat sink system. The relative light output with the heat sink system reaches a maximum value slower than its counterpart without a heat sink. After four hours of operation the relative light output of the fixture has dropped only 1-2% from its maximum value. This represents an increase in light output of approximately 20% in comparison to the same fixture operating without the heat sink.

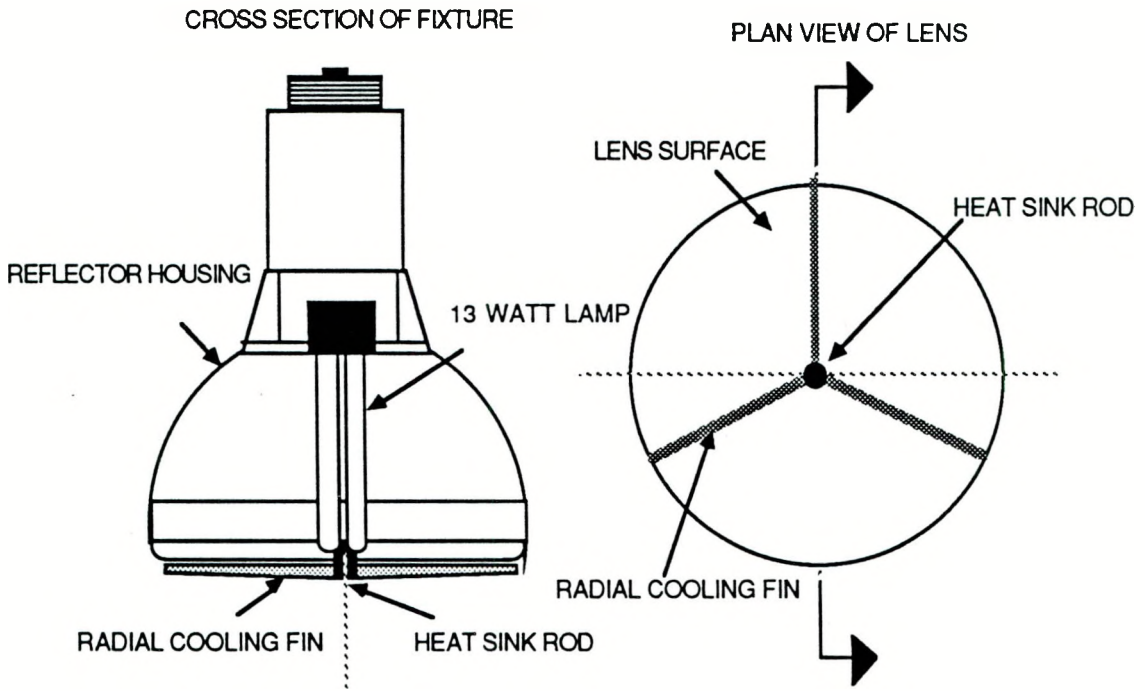

Figure 5. Compact screw-in fixture with radial fin heat sink.

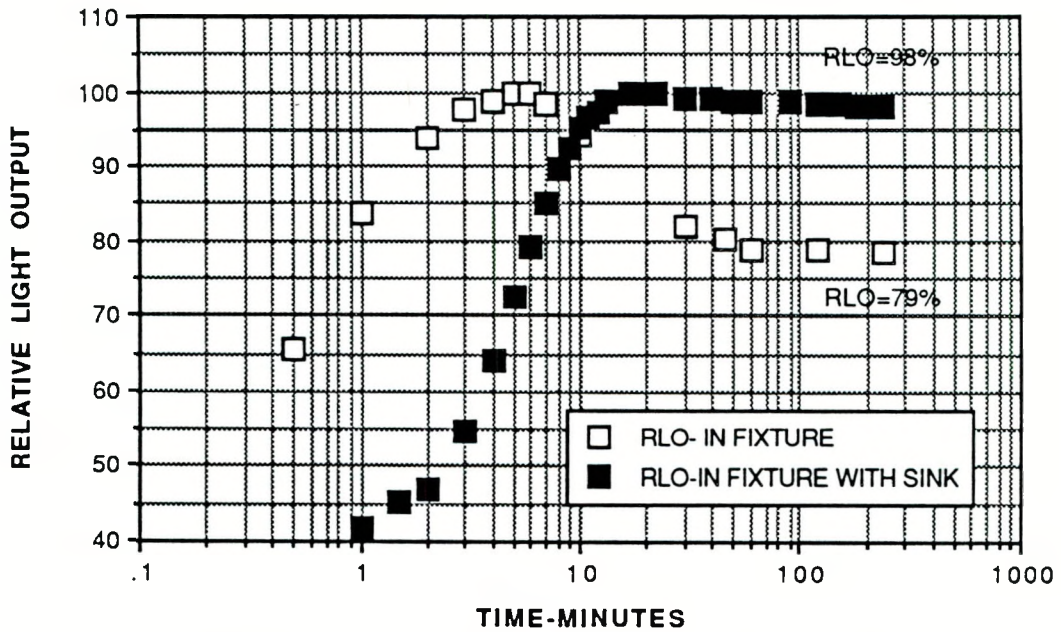

Figure 6. Relative light output for 13 watt fluorescent with and without heat sink.

Dedicated compact fluorescent fixtures

A series of dedicated downlight compact fluorescent fixtures were tested using the same experimental apparatus as described previously. These dedicated fixtures typically include a spun reflector housing and a hard-wired ballast in a separate compartment. These fixtures are typically recessed mounted in a dropped ceiling plenum. The fixtures may be designed with an open or lensed ceiling aperture. The compact fluorescent lamps are mounted either horizontally or vertically and can accommodate single or double lamp combinations. Lamp wattages range from 13 to 26 watts. In this series of experiments open downlight fixtures were mounted in the test station as described previously.

13 Watt recessed fixture

This fixture consists of a single 13 watt compact fluorescent lamp mounted vertically with the base up. The fixture is made up of a internal reflector housed inside an external cylindrical canister designed for recessed mounting in a dropped ceiling. The fixture has an open geometry and no lens. Figure 7 shows a cross section of the fixture. Figure 8 shows the relative light output over time for this fixture. After four hours of operation, relative light output stabilized at 82%, indicating an 18% loss in light due elevated lamp wall temperature conditions.

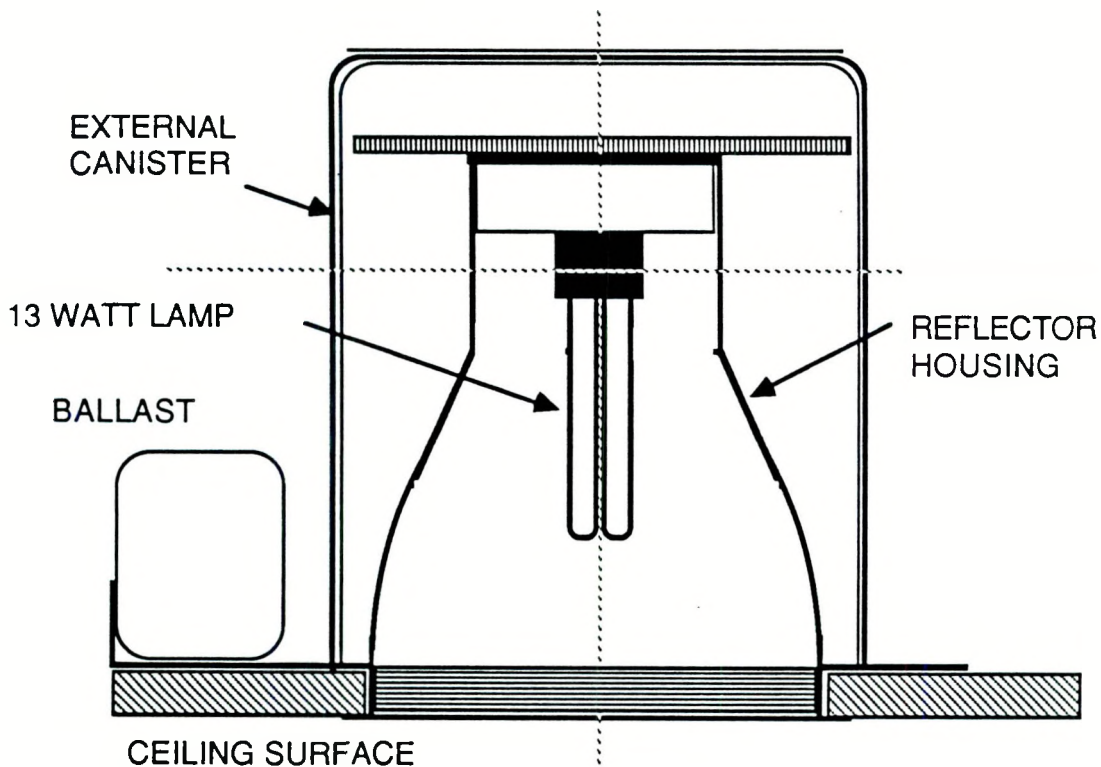

Figure 7. 13 watt compact fluorescent.

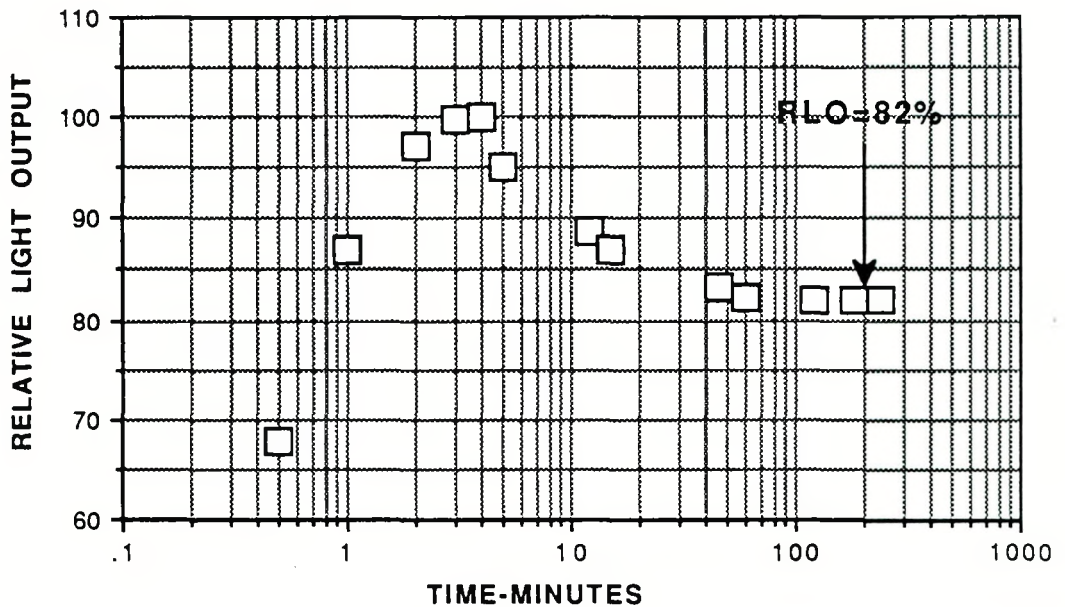

Figure 8. Relative light output for 13 watt compact fluorescent fixture.

Supplemental smoke studies showed that despite the open ceiling aperture a warm air layer was trapped inside the fixture reducing convective cooling of the lamps and increasing lamp wall temperatures.

26 Watt recessed fixture

This fixture uses two 26 watt lamps mounted horizontally near the top of an open reflector. We tested the fixture in two configurations: 1) as shipped by the manufacturer and 2) with two slots cut into the top of the reflector to test the effect of venting on lamp wall temperature and light output. Figure 9 shows a cross section of the first configuration. Figure 10 provides a cross section of the modified fixture showing the position of the two vents. Convection patterns as determined by smoke flow testing are also indicated.

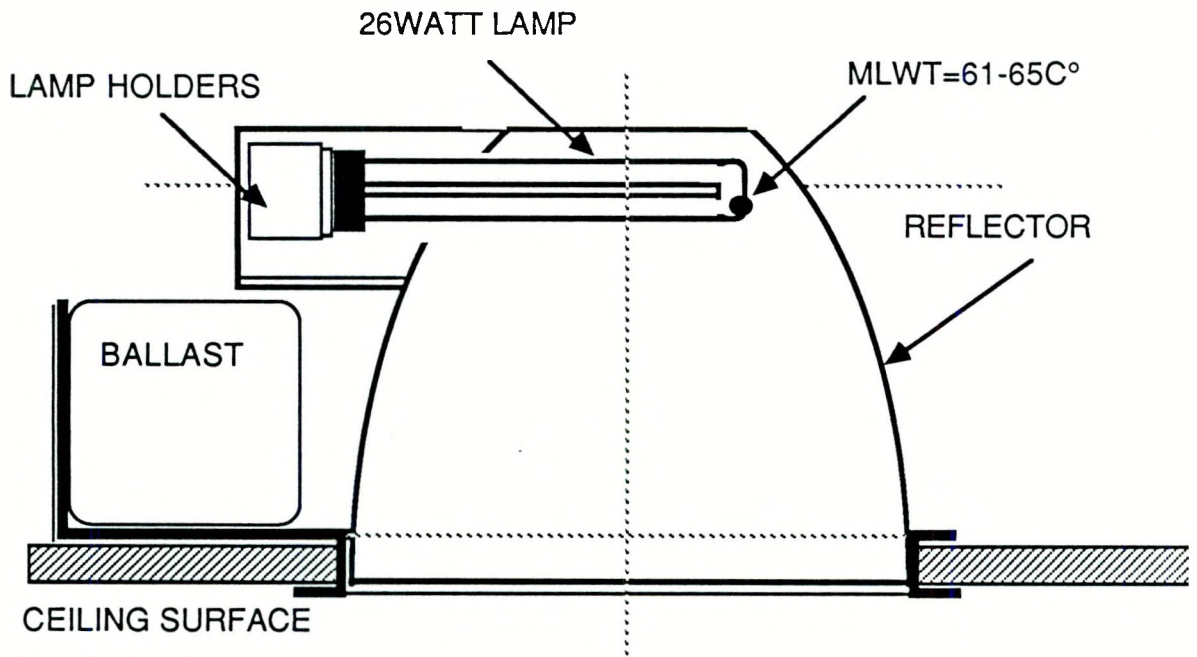

Figure 9. Cross section of 2x26 watt fluorescent fixture.

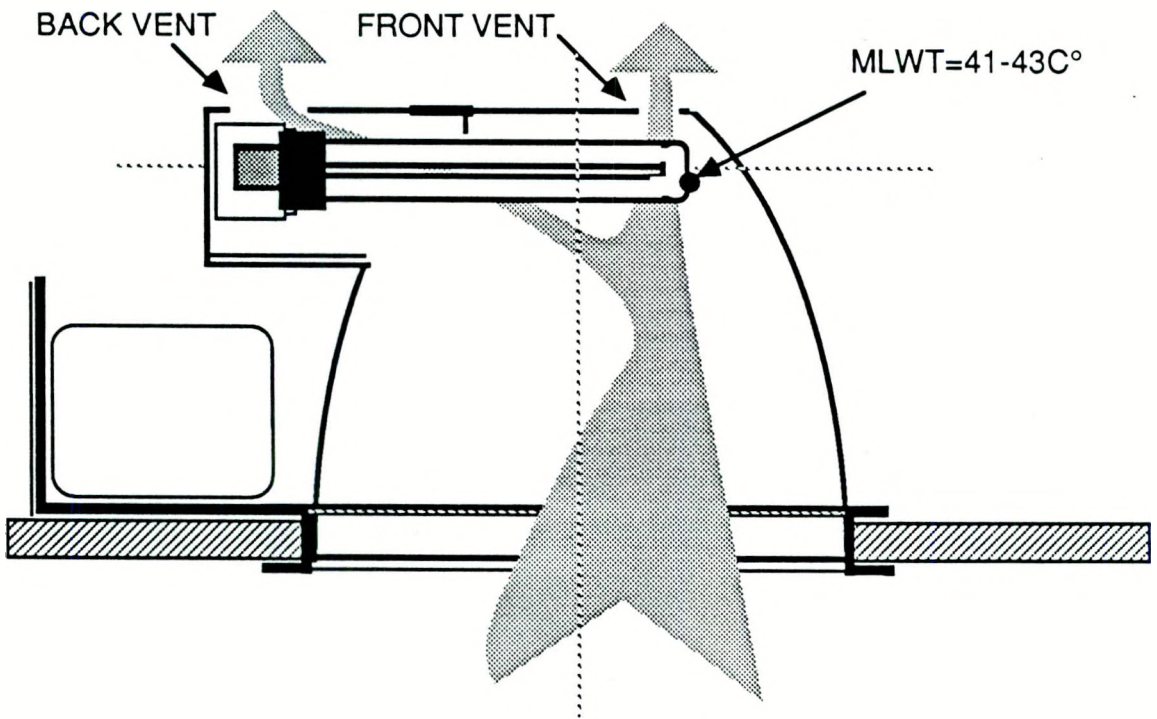

Figure 10. Cross section of 2x26 watt fluorescent fixture with vents.

Figure 11 shows the relative light output as a function of time for both the vented and non-vented recessed downlight. The standard fixture stabilizes with a MLWT of 61-65°C at which point the fixture is operating at a relative light output of 79%.

The vented fixture was tested with only the back vent open until the fixture reached equilibrium with a MLWT of 47-50°C. At this point, the fixture was operating at 90% relative light output. Then we also opened the front vent so that the fixture was operating with both vents open. After 3 hours of operation the lamp temperature was further reduced to 41-43°C. This increased the relative light output to 93% of maximum.

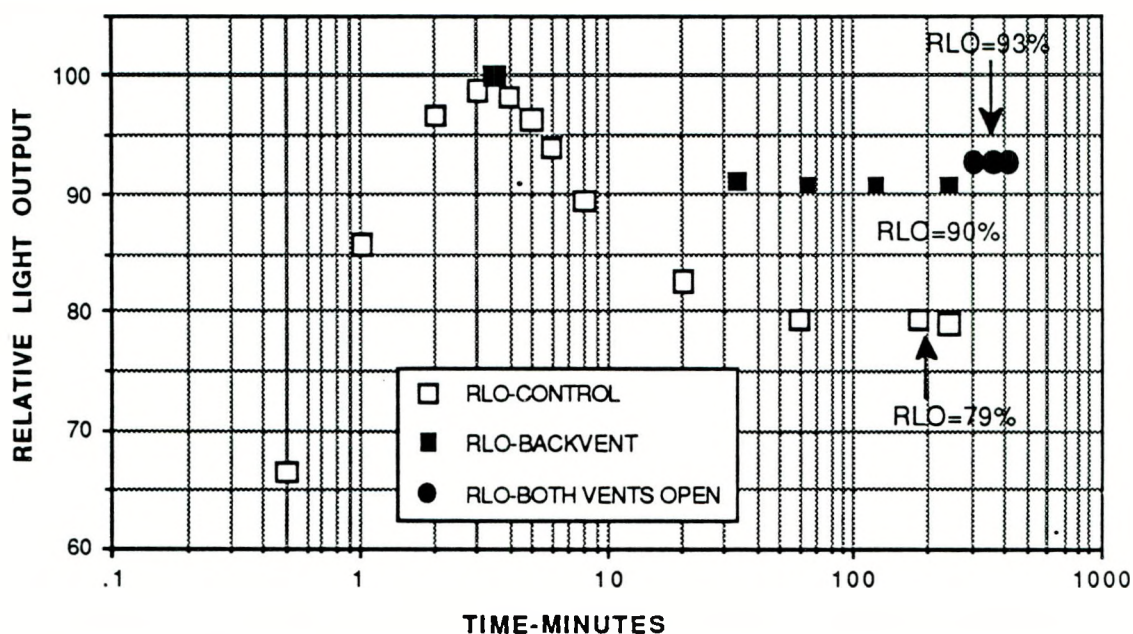

Figure 11. Relative light output for 2x26 watt fluorescent fixture, vented and unvented.

We observed that opening the front vent (which was located immediately above the elbow of the compact lamp where the cold spot is located) caused an optical loss of approximately 5% because light is lost to the plenum space above. We estimated this loss by covering the front vent aperture momentarily (to avoid thermal interaction) with a mirror surface and observing the change in light output. With only the back slot open, we could not measure any loss in optical efficiency attributable to the presence of the vent.

To understand more clearly the variations in fixture output and lamp output at different lamp wall temperatures, the bare lamps were photometered inside a temperature controlled integrating chamber. Figure 12 shows the variations in light output as a function of minimum lamp wall temperature for MLWTs between 30 and 70°C. This data was obtained using the same

lamp/ballast system as was used in the fixture and with the lamps in the same horizontal position. Measured MLWTs for both the vented and non vented fixture configurations are indicated on the curve.

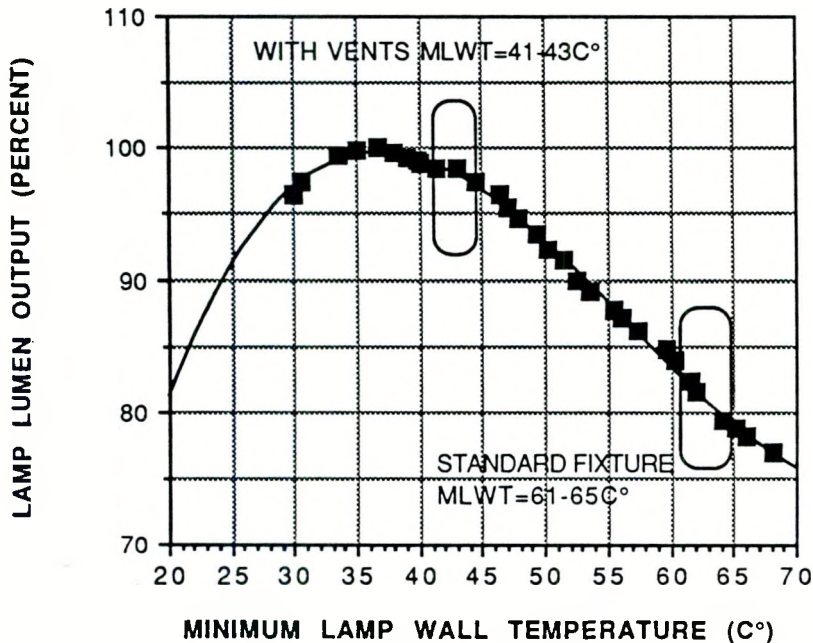

Figure 12. Light output vs. minimum lamp wall temperature for 26 watt compact fluorescent lamp.

Discussion

The results show that elevated temperatures inside the fixture reduce the light output of the compact fluorescent lamp to 79-84% of its maximum value.

To retrofit an existing incandescent fixture with a screw-in compact fluorescent fixture generally requires that the compact fluorescent fixture provide the equivalent fixture lumens¹ as the incandescent it supplants. For example, based on the rated lumen output, a 60 incandescent lamp (870 lumens) would be replaced with a 13 watt compact fluorescent lamp (900 lumens). However, because the optical efficiency of the fluorescent fixture is typically lower than that of the incandescent fixture, the fixture lumens for the fluorescent lamp will be lower than the incandescent. If we include the 20% thermally-induced light loss measured in this paper, the fluorescent fixture lumens will be sufficiently low that the fluorescent retrofit might have to be rejected. (Using compact fluorescents with wattages higher than 13

¹Fixture lumens is defined to be the total number of lumens exiting the fixture.

watts are often impractical due to fixture size constraints). However, we have shown that the thermally-caused light loss can be virtually eliminated by the application of an appropriately configured external heat sink. Restoring the lamp temperature to its optimum point in this manner may therefore allow the implementation of a very cost-effective energy-conserving measure that would otherwise be precluded because of low fixture output.

For new construction, the fixture spacing can be chosen so that (within limits) a specific design light level can be achieved regardless of the fixture's lumen output. Thus in new construction, one need not reject the 13 watt fluorescent fixture considered above based on its lower lumen output. But there is still an efficacy penalty associated with operating a fluorescent lamp at a higher MLWT than optimum. At MLWTs significantly above the optimum, light output *and* efficacy steadily decrease. While the reduction in efficacy for a given change in MLWT is not as great as the reduction in light output, it is still significant. (For the standard T12 fluorescent system, a thermally induced drop of 20% drop in lumen output corresponds to a 10% drop in system efficacy. Preliminary data suggests that similar performance decrements are associated with the compact fluorescent lamp system.) The technique of venting the dedicated compact fluorescent fixture therefore increases the lumen output of the fixture to near maximum and also increases the efficacy with which that light is produced. Thus compared to the non-vented fixture, fewer vented fixtures would be required to provide a specified light level and the lighting system's efficacy would be improved.

Two methods for reducing lamp temperature have been presented. One involves direct lamp cooling using heat sink geometries, the other involves cooling the lamp compartment with some kind of convective venting. Both approaches would involve design modifications that should be implemented at the point of manufacture. Venting approaches are well suited to application in dedicated fixtures that are recessed into the plenum. Modifications would involve incorporating small vents in the reflector housing consistent with Underwriters Laboratory requirements. Venting screw-in or retrofit fixtures presents difficulties as the existing fixture in the ceiling may present a completely enclosed geometry which would limit the convection to the plenum. This suggests that heat sinks or other similar methods that conduct heat away from the lamps may be appropriate.

Conclusion

This work has shown that substantial losses in light output and fixture efficiency can occur due to elevated temperatures inside a compact fluorescent fixture. Depending on the specific fixture type, we found that the light output was between 16-21% below maximum. Two methods for improving the thermal performance of compact fluorescent fixtures were presented. These

methods were shown to be effective in reducing the minimum lamp wall temperature to near the optimum point.

Acknowledgement

The work described in this paper was supported by the Assistant Secretary for Conservation and Renewable Energy, Office of Building Technologies, Buildings Equipment Division of the U.S. Department of Energy under Contract No. DE-AC03-76SF00098.

LAWRENCE BERKELEY LABORATORY
UNIVERSITY OF CALIFORNIA
INFORMATION RESOURCES DEPARTMENT
BERKELEY, CALIFORNIA 94720