



# Lawrence Berkeley Laboratory

UNIVERSITY OF CALIFORNIA

RECEIVED  
LAWRENCE  
BERKELEY LABORATORY

FEB 21 1984

LIBRARY AND  
DOCUMENTS SECTION

## APPLIED SCIENCE DIVISION

IMPROVING THE ENERGY EFFICIENCY OF RESIDENTIAL  
CLOTHES DRYERS

D. Hekmat and W.J. Fisk

July 1983

### TWO-WEEK LOAN COPY

*This is a Library Circulating Copy  
which may be borrowed for two weeks.  
For a personal retention copy, call  
Tech. Info. Division, Ext. 6782.*

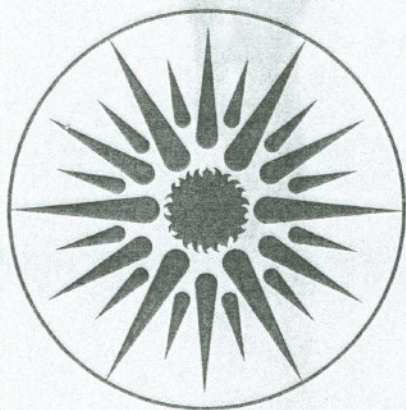

APPLIED SCIENCE  
DIVISION

LBL-16813  
c.2

IMPROVING THE ENERGY EFFICIENCY OF RESIDENTIAL CLOTHES DRYERS

Dariusch Hekmat and William J. Fisk

Applied Science Division  
Lawrence Berkeley Laboratory  
University of California  
Berkeley, CA 94720

July 1983

This work was supported by the Assistant Secretary for Conservation and Renewable Energy, Office of Building Energy Research and Development, Building Systems Division of the U.S. Department of Energy under Contract No. DE-AC03-76SF00098.

## ABSTRACT

This report presents an experimental study on energy efficient electrical domestic clothes dryers. A literature survey was performed and four basic energy saving techniques were identified: (1) reduced air flow rate and heater input, (2) recirculation of a portion of the exhaust air back into the clothes dryer, (3) heat recovery, utilizing an air-to-air heat exchanger, and (4) 100% recirculation of air through the dryer and a heat pump to condense water out of the air. Reduced air flow rate and heater input leads to energy savings around 8%, while recirculation of exhaust air reduces the energy consumption by approximately 18%. Because of the low cost of these two measures, they should be pursued by the manufacturers. When utilizing an air-to-air heat exchanger for heat recovery, two modes are considered. The first is to preheat the inlet air with heat from the exhaust air, which results in 20 to 26% energy savings depending upon the location of the dryer in the house. The second more attractive mode is 100% recirculation of air and condensation of water from this air in the heat exchanger (using indoor air as a heat sink) and represents a 100% heat recovery but leads to a 1 to 6% increase in energy consumption. The development of a clothes dryer equipped with an air-to-air heat exchanger and a summer/winter switch (preheating mode in the summer and recirculation/condensation mode in the winter) should be pursued by the manufacturers. Recirculation through a heat pump with condensation again gives a 100% heat recovery and can save up to 33% in energy consumption but yields long drying times due to limitations of the condenser temperature. Further research and development is needed to improve the performance of a heat pump for this application (i.e. units that operate at higher condenser temperatures are desirable), and to study the feasibility of vacuum drying (i.e. using a liquid ring pump).

Keywords: air-to-air heat exchanger, clothes dryer, energy conservation, energy consumption, energy efficiency, heat pump, heat recovery, residential dehumidifier.

## TABLE OF CONTENTS

	<u>Page</u>
1. INTRODUCTION.....	1
2. ENERGY CONSUMPTION OF CLOTHES DRYERS.....	1
3. LITERATURE REVIEW.....	2
4. ANALYTICAL STUDY.....	8
4.1 Analysis of Drying Process.....	8
4.2 Description of Energy Saving Techniques.....	10
4.2.1 Reduced Air Flow Rate.....	10
4.2.2 Recirculation of Exhaust Air.....	11
4.2.3 Heat Recovery, Utilizing an Air-to-Air Heat Exchanger.....	12
4.2.3.1 Preheating Mode.....	13
4.2.3.2 Recirculation/Condensation Mode.....	16
4.2.4 Recirculation with Condensation, Utilizing a Heat Pump.....	18
5. EXPERIMENTAL STUDY.....	19
5.1 Description of Experimental System and Test Procedure.....	19
5.2 Test Results.....	20
5.2.1 Baseline Experiments.....	20
5.2.2 Experiments With Reduced Air Flow Rate.....	22
5.2.3 Recirculation Experiments.....	23
5.2.4 Heat Recovery Experiments.....	25
5.2.4.1 Preheating Mode.....	25
5.2.4.2 Recirculation/Condensation Mode.....	26
5.2.5 Experiments with a Heat Pump.....	29
6. SUMMARY AND RECOMMENDATIONS.....	30
Acknowledgements.....	34
References.....	35
Appendix A: Numerical Calculation for the Baseline.....	37
Appendix B: Numerical Calculation for Heat Recovery, Utilizing an Air-to-Air Heat Exchanger in the Preheating Mode..	41
Appendix C: Increase of Infiltration Rate During Clothes Dryer Operation.....	43
Appendix D: Accuracy of Measurements and Reproducibility.....	44

LIST OF TABLES

	<u>Page</u>
Table 1. Summary of Tests.....	47
Table 2. Reduced Data for Baseline Tests.....	48
Table 3. Reduced Data for Reduced Air Flow Rate Tests.....	49
Table 4. Reduced Data for Recirculation Tests.....	50
Table 5. Reduced Data for Heat Exchanger-Preheat Tests.....	51
Table 6. Reduced Data for Heat Exchanger-Recirculation Tests....	52
Table 7. Reduced Data for Dehumidifier and Dehumidifier/Heat Exchanger Tests.....	53
Table 8. Comparison of Experimental Results with the Theoretical Calculation for the Baseline.....	54
Table 9. Comparison of Energy Savings and Drying Times.....	55
Table 10. Summary of Technical Improvements and Energy Saving Measures.....	56

## LIST OF FIGURES

	<u>Page</u>
Figure 1. Schematic Diagram of Clothes Dryer.....	57
Figure 2. Psychrometric Chart Including Drying and Heat Recovery Process.....	57
Figure 3. Schematic Diagram of Dryer with Recirculation.....	58
Figure 4. Schematic Diagram of Dryer with Heat Recovery, Preheating Mode.....	58
Figure 5. Schematic Diagram of Dryer with Heat Recovery, Recirculation/Condensation Mode.....	59
Figure 6. Schematic Diagram of Dryer with a Heat Pump.....	59
Figure 7. Top and Front View of Clothes Dryer.....	60
Figure 8. Transient Operating Temperatures for Baseline and Recirculation Tests.....	61
Figure 9. Transient Operating Temperatures for Baseline and Heat Exchanger-Recirculation Tests.....	62
Figure 10. Transient Relative Humidities.....	63
Figure 11. Transient Absolute Humidities.....	64
Figure 12. Drying Kinetics for Baseline and Heat Exchanger Recirculation Tests.....	65
Figure 13. Schematic Diagram of Clothes Dryer with a Heat Pump and an Air-to-Air Heat Exchanger.....	66
Figure 14. Comparison of Evaporation Rates.....	67
Figure 15. Comparison of Energy Savings.....	68
Figure 16. Schematic Diagram of Vacuum Clothes Drying.....	69
Figure 17. Infiltration and Exfiltration Versus Pressure Difference in a House.....	70

## Nomenclature

C	capacity rate
$C_p$	specific heat at constant pressure
$C_{p_{H_2O}}$	specific heat of water vapor at constant pressure
h	enthalpy
$h_{fg}$	heat of evaporation
m	mass
$\dot{m}$	mass flow rate
$\dot{m}_{H_2O}$	water evaporation rate or rate of water condensation in the heat exchanger
P	electric heater power
p	pressure
Q	heat
$\dot{Q}$	power
RH	relative humidity
T	temperature
t	time
V	volume
$\dot{V}$	air flow rate
X	absolute humidity (mass of water vapor/mass of dry air)
$\epsilon$	heat exchanger effectiveness
$\rho$	density

## Indices

CR	cold return
CS	cold supply
c	cold
f	forced
HR	hot return
HS	hot supply
h	hot
in	inlet
mix	mixture of recirculated and ambient air
out	outlet
sens.	sensible
spec.	specific
tot.	total
$\infty$	ambient space
$(\bar{\quad})$	average
$(\dot{\quad})$	time derivative

## 1. INTRODUCTION

As energy prices rise and non-renewable energy sources become less abundant, it becomes more important to decrease energy consumption in the residential sector. Significant research has been done on energy efficient buildings, i.e. reducing the air infiltration rate and heat losses through the building's shell. Another important factor is the energy consumed by home appliances, which was about 6.8% of the U.S. energy budget in 1977, water heaters and air conditioning included.

This report contains a literature review of existing research on clothes dryers and an analytical and experimental assessment of promising techniques to increase the dryer efficiency and/or to recover heat from the exhaust air of electrically heated residential clothes dryers.

## 2. ENERGY CONSUMPTION OF CLOTHES DRYERS

Approximately 9% of the primary energy used in the household sector is consumed by the laundry process and 30% of that is used in the drying process. This energy consumption amounted to 0.57% of the total annual United States primary energy consumption in 1978. The total number of clothes dryers in 1978 was 45 million and the ratio of electrical clothes dryers to gas-fired clothes dryers was about 2.5 to 1. The average service life of a clothes dryer is 13 years.<sup>1</sup>

Two field studies on residential electric laundry dryer load characteristics were performed by Pacific Gas and Electric Company (PG&E)<sup>2</sup> and Oklahoma Gas and Electric Company (OG&E)<sup>3</sup> in 1965 and 1971, respectively. The PG&E survey gives an annual power consumption of 1,400 kWh

for an average family size of 4.5 people. The OG&E load survey measured 1,320 kWh/year for an average family size of 4.8 people. Assuming that the energy consumption per load is 3.0 kWh, there will be approximately 450 drying loads per year, on the average. At a typical electricity price of \$0.075/kWh, the cost for operating a domestic electric clothes dryer would then be around \$100 a year.

### 3. LITERATURE REVIEW

Preliminary studies to conserve heat contained in the exhaust air of laundry dryers originated in the early sixties and proposed the utilization of air-to-water heat exchangers to preheat the feedwater of water heaters.

Early efforts to reduce energy consumption in commercial and industrial clothes dryers were initiated in 1964 by J.J. Angelone,<sup>4</sup> who suggested partial recirculation of exhaust air directly into the rotating drying chamber, thus retaining part of the heat which would normally be discharged through the exhaust conduit. Disadvantages of this approach are recirculation of moisture, lint and, in the case of a gas-fired dryer, products of combustion.

In 1975, Frank H. Winstel<sup>5</sup> proposed the utilization of a shell-and-tube air-to-air heat exchanger to preheat the incoming fresh air with the waste heat of the exhaust air. This practice would eliminate the problem of mixing exhaust and fresh air. Savings up to 50% of the energy requirement of an electrically heated or gas-fired laundry dryer were predicted. However, it was stated that an additional blower is needed and that the heat recovery equipment has to be custom-made and is

therefore expensive.

The Federal Energy Administration prepared a document on technical background information for clothes dryer efficiency targets in April 1976,<sup>6</sup> which proposed a number of technical improvements for residential clothes dryers. These include: added insulation to the interior ducts to prevent heat loss to the surroundings, air flow design changes to reduce air bypasses, recirculation of part of the exhaust air, preheating the inlet air by means of a heat exchanger, venting to indoors in the winter, improving the automatic termination systems, improving seals at dryer drum and door to reduce air leaks, and using high efficiency electric motors for blower and drum drive. The range of efficiency improvement, costs, marketability, and consumer acceptance are briefly discussed. The efficiency improvements are estimated to be in the range of 2% to 15%.

Another approach to improve the efficiency of industrial drying was examined experimentally in 1976 in England by D.L. Hodgett,<sup>7</sup> by using a heat pump to remove moisture from the exhaust air and recirculating the air. A limitation was the maximum operating temperature of about 50°C for the condenser of the heat pump. No data on energy savings was given.

Andrew J. Fowell<sup>8</sup> presented a paper at the Conference on Major Home Appliance Technology for Energy Conservation in February/March 1978 and pointed out the interrelation of a dryer and the indoor environment (increased infiltration rates during dryer operation). He mentioned a counterflow coaxial heat exchanger arrangement to preheat the inlet air which could be drawn from outdoors, thus eliminating the draft on the house. However, no calculations were performed for energy savings

estimates.

In 1979, Odean F. George<sup>9</sup> suggested the utilization of heat pipes in an air-to-water heat exchanger instead of conventional copper coils. He integrated a number of commercial laundry dryers into the feedwater system of a water heater, which provided hot water for about the same amount of clothes washers in the laundry. Since the heat pipes work as a thermal diode, the improvement is that little heat loss occurs when the dryers are shut down.

A report on clothes washers and dryers was published by W.P. Levins in April 1980 at the Oak Ridge National Laboratory.<sup>10</sup> It analyzes the energy usage of these two appliances and the applications of various techniques on energy conservation. Tests on the effect of dryers on the infiltration rate of a house were performed, and resulted in the finding that the increase in infiltration rate due to forced exhaust ventilation when operating an outside vented dryer was smaller than expected. It was 25 cfm instead of 120 cfm in a house with an infiltration rate of 190 cfm when the dryer was not in use. This leads to the fact that it can not be assumed that the total infiltration rate of a house is simply the sum of the infiltration rate due to wind, stack, etc. and the air flow rate of the dryer exhaust, when operating a dryer (see Appendix C). As a result, measures that reduce the draft on a house will result in only small energy savings. In addition, for instance in the case of using an electrical clothes dryer in a gas heated house, operation in the heated section of the house is worthwhile, since the dryer inlet air is preheated using the less-expensive gas heat and electrical energy savings in the order of 5-6% can be expected. Utilization of exhaust

heat by preheating the inlet air with a heat exchanger is also discussed in this report, however, latent heat recovery is not considered. Energy saving estimates are around 5%. It is mentioned that the lint filtration can be improved by using a fine nylon mesh filter instead of the normally used coarse metal mesh.

The Department of Energy in cooperation with the American Health Care Association carried out a study in 1981,<sup>11</sup> which resulted in guidelines to recover the heat generated by medium to heavy clothes dryers (designed for 30-200 lbs of load). Heat recovery devices such as rotary heat exchangers and stationary counterflow air-to-air heat exchangers were proposed, as well as exhaust air recirculation. In the latter case, energy savings up to 20% were predicted. It was noted that proper care has to be taken of recirculated lint and moisture and that the drying time might be slightly increased.

In November 1981, a report on heat recovery from domestic clothes dryers was published by K.T. Feldman and G.J. Tsai.<sup>12</sup> This study presents calculations of the technical and economical feasibility of utilizing a counterflow shell-and-tube type air-to-air heat exchanger or a heat pipe heat exchanger and predicts heat recoveries of 18% or 40-60%, respectively. Disadvantages that are noted are high equipment costs yielding long payback periods. Recirculation of 50% of exhaust air is also proposed with estimated energy savings of 15-20%.

A study of several ways to reduce energy consumption in a commercial laundromat was conducted in 1981 and presented in a report by T.K. Murphy and S. Greenberg in December 1981.<sup>13</sup> Air-to-air heat recovery was abandoned because low heat transfer coefficients necessitated the use of

heat exchangers with large surface areas, and because of fouling of the heat exchangers with lint. However, recovery of latent heat had not been taken into account. Air-to-water heat recovery was proposed with an energy savings estimation of approximately 15%.

In addition to energy saving measures reported in the literature, measures that have been undertaken by manufacturers deserve mention. In many of the dryers marketed in Europe, the direction of rotation of the drum reverses periodically throughout the drying cycle. This helps to prevent clothes from rolling up into a configuration that is compact and difficult to dry. Also available in Europe are clothes dryers that recirculate the exhaust air through an air-to-air heat exchanger (where water is removed by condensation using the indoor air as a heat sink). An advantage of these units is that no exhaust connection to the outdoors is needed. However, if the clothes dryer is operated in a small room the room air temperature can rise substantially during operation. This results in a decrease of the temperature gradient across the heat exchanger and thus the condensation rate is reduced. Therefore, a sufficient volume of room air has to be available. It should be noted that these clothes dryers with exhaust air recirculation through an air-to-air heat exchanger were primarily designed to eliminate the need of a vent, not to reduce energy consumption. Nothing was mentioned about heat recovery in the product literature. The two available clothes dryers equipped with air-to-air heat exchangers available in West Germany consumed 21-47% more electricity and required 20-53% more drying time, according to the product literature.

In cases where no venting is possible and overheating of the indoor space is likely, recirculation and condensation using an air-to-water heat exchanger is a possible approach. In Europe, clothes dryers with an air-to-water cascade heat exchanger have been developed and are available on the market. A considerable amount of cold tap water is used during dryer operation and the moisture of the warm humid exhaust air is removed by direct contact with the water, which is then drained. The dryer exhaust heat is lost as long as there exists no grey water heat recovery system.

Manufacturers in the U.S. and elsewhere are also marketing and developing dryers with improved cycle termination controls, including controls that sense air humidity or clothes moisture content.

An inexpensive energy saving measure is to simply vent the exhaust air to indoors during the winter and a variety of manufacturers market valve systems for this purpose. This may be a suitable technique in some situations, but the latent heat in the vented air is not recovered unless moisture condenses on indoor surfaces. Excessive condensation of moisture and high humidity may result especially in energy efficient (air tight) residences. In addition, if a gas-fired dryer is vented to indoors, high indoor concentrations of potentially harmful combustion products (e.g., nitrogen dioxide and carbon monoxide) may result.

One last category of energy saving measures that is not discussed in the literature, is to modify the consumers behaviors. The high average number of drying loads per year (518) reported in the 1971 study by Oklahoma Gas and Electric Co. suggests that in many instances, only a small amount of clothes are dried per load which likely results in less

efficient drying. Less frequent drying of larger loads could save significant energy. In response to energy price increases since 1971, some homeowners may have already modified their behavior in this manner.

In summary, a large number of energy saving measures are reported in the literature. Estimates of energy savings range from a few percent reduction in dryer energy consumption to 100% delivery of the energy consumed to the indoor air. In only a few instances, however, have actual measurements of energy savings been performed. In the remainder of this report an analytical and experimental analysis of various energy saving measures is presented.

#### 4. ANALYTICAL STUDY

This chapter presents an analysis of the drying process in clothes dryers and descriptions of four techniques to reduce the dryer energy consumption. The techniques described are: (1) reduced air flow rate, (2) recirculation of exhaust air, (3) heat recovery utilizing an air-to-air heat exchanger, and (4) recirculation with condensation, utilizing a heat pump.

##### 4.1 Analysis of the Drying Process in Clothes Dryers

The following simple balances refer to the schematics of an electrically heated clothes dryer presented in Figure 1. We assume that the sensible heat change of the clothes, the mechanical power input and the heat transfer to ambient are negligible.

Mass balance:

$$\dot{m}_{\text{air}} (1 + X_{\infty}) + \dot{m}_{\text{H}_2\text{O}} = \dot{m}_{\text{air}} (1 + X_{\text{out}}) \quad (1)$$

Energy balances:

Heating element

$$\dot{m}_{\text{air}} h_{\infty} + P = \dot{m}_{\text{air}} h_{\text{in}} \quad (2a)$$

Evaporation

$$\dot{m}_{\text{air}} h_{\text{in}} + \dot{m}_{\text{H}_2\text{O}} h_{\text{H}_2\text{O}} = \dot{m}_{\text{air}} h_{\text{out}} + \dot{Q}_{\text{evap.}} \quad (2b)$$

We get:

$$\dot{m}_{\text{air}} (C_{p_{\text{air}}} + X_{\infty} C_{p_{\text{H}_2\text{O}}}) T_{\infty} + P \quad (2a)$$

$$= \dot{m}_{\text{air}} (C_{p_{\text{air}}} + X_{\infty} C_{p_{\text{H}_2\text{O}}}) T_{\text{in}}$$

and

$$\dot{m}_{\text{air}} (C_{p_{\text{air}}} + X_{\infty} C_{p_{\text{H}_2\text{O}}}) T_{\text{in}} + \dot{m}_{\text{H}_2\text{O}} C_{p_{\text{H}_2\text{O}}} (\bar{T}) \bar{T} =$$

$$\dot{m}_{\text{air}} (C_{p_{\text{air}}} + X_{\text{out}} C_{p_{\text{H}_2\text{O}}}) T_{\text{out}} + \dot{m}_{\text{H}_2\text{O}} h_{fg} (\bar{T}), \quad (2b)$$

$$\text{with } \bar{T} = \frac{T_{\text{out}} + T_{\text{in}}}{2} .$$

In the following section, the drying process is analyzed qualitatively with the help of a psychrometric chart (Figure 2). Step 1 → 2 is the process of heating up the incoming fresh air from the ambient temperature  $T_{\infty}$  to the temperature after the heating element  $T_{\text{heater}}$ . The absolute humidity is constant at  $X_{\infty}$ . Step 2 → 3 is the evaporation process with an increase of the absolute humidity from  $X_{\infty}$  to  $X_{\text{out}}$  and a corresponding temperature drop from  $T_{\text{heater}}$  to  $T_{\text{out}}$ . Step 3 → 1 represents the recovery of sensible and latent heat which is contained in the warm, moist exhaust air, assuming that the dryer is vented indoors and the volume of the house is infinite. We also assume, that all water which has condensed indoors is reevaporated. Then we obtain the equation for the sensible heat gain:

$$\dot{Q}_{\text{sens. } 3 \rightarrow 1} = \dot{m}_{\text{air}} (C_{p_{\text{air}}} + X_{\text{out}} C_{p_{\text{H}_2\text{O}}}) (T_{\text{out}} - T_{\infty}) . \quad (3)$$

A numerical calculation of the drying process is presented in Appendix A. See Chapter 5.2.1 for experimental results.

## 4.2 DESCRIPTION OF ENERGY SAVING TECHNIQUES

### 4.2.1 Reduced Air Flow Rate

The drying process in a clothes dryer involves turbulent flow, forced convection heat transfer, and mass transfer with a phase change. It consists mainly of two mechanisms, diffusion and convection. The

evaporating water diffuses from the inside of the wet clothes to their surface by capillary action and then into the surrounding hot air, which was previously heated by a radiant electric resistance heater. The air removes the moisture through convection to the exhaust conduit. The parameters which primarily control the rate of mass transfer of water are the air flow rate and the air temperature which affects the water vapor pressure at the surface of the clothes. The idea of reducing the air flow rate is to manipulate the kinetics of the drying process in such a way that the increase in evaporating rate, due to higher air temperatures, might yield a better energy transfer efficiency, although convection is decreased. Also, since the fresh air is generally drawn from indoors and the exhaust air is vented to outdoors, reduced air flow rate results in a smaller draft in the building. Thus, air infiltration is decreased saving space heating or cooling energy. However, these savings are small, as mentioned above. In addition, the energy used by the blower may be reduced.

A quantitative study of heat and mass transfer coefficients in this case is difficult and beyond the scope of the present report.

#### 4.2.2 Recirculation of Exhaust Air

An easy and cheap way to recover the exhaust heat is recirculating a part of it back into the clothes dryer. Two possibilities exist: (1) recirculation of air directly into the drying chamber, or (2) mixing of recirculated air with fresh air previous to entry into the heating element. The operating temperatures are increased as well as the absolute humidity of the air, and some energy savings are expected. However, the effects of higher temperatures and humidities again counteract each

other in terms of the drying kinetics (i.e., the evaporation rate decreases with the increase of humidity but increases with an increase in temperature).

To recirculate exhaust air, simple and inexpensive modifications of the ductwork are required. In addition, lint filters with a better efficiency have to be installed primarily to prevent hazards that may result due to lint accumulation and subsequent combustion. Current safety codes in many areas do not permit recirculation. Figure 3 shows the clothes dryer with recirculation schematically. Unknowns are: (1) the recirculation ratio, (2) the inlet and outlet temperatures and humidities, both being time dependent, and (3) the evaporation rate. Theoretical calculations, to compare with the experimental analysis of the heat recovery technique, are relatively complicated due to complex drying kinetics.

#### 4.2.3 Heat Recovery, Utilizing an Air-to-Air Heat Exchanger

Air-to-air heat exchangers have been successfully used for recovering heat from ventilation air and for many industrial processes. The effectiveness of units used in residences is around 40 to 75% and sensible heat is primarily recovered.<sup>14</sup> However, the exhaust air of a clothes dryer contains a considerable amount of moisture and it is desirable to recover its latent heat. Advantages of heat recovery with an air-to-air heat exchanger are good source-load matching and no or minimal mixing of fresh air and exhaust air. Problems are that a large heat transfer surface area is required, hence the cost of the hardware is high, and that lint may accumulate on the heat transfer surfaces. Although every clothes dryer is equipped with a lint filter, considerable lint is still

contained in the exhaust air. This lint can foul the heat exchanger, thus decreasing its effectiveness. In the following section, an integral analysis of the drying process with heat recovery, utilizing an air-to-air heat exchanger, is given.

#### 4.2.3.1 Preheating Mode

One energy saving technique is to preheat the inlet air with the exhaust air. To overcome the additional resistance to airflow, an additional blower is needed at the fresh air inlet or at least a stronger blower in the exhaust duct is required. Energy savings are either achieved through faster drying or a reduction in the heater input power. In the case of sufficient temperature gradients across the core of the heat exchanger, condensation and thus latent heat recovery is possible. The inlet air can be drawn from outdoors, thus decreasing the draft in the building. Figure 4 gives a schematic diagram of the dryer-heat exchanger configuration in the preheating mode. A counterflow heat exchanger is used. The equation that describes the rate of heat transfer is:

$$Q = \epsilon C_{\min} (T_{HS} - T_{CS}) \quad (4)$$

where  $C_{\min}$  is the smaller of the heat capacities of the two airstreams passing through the heat exchanger, and  $\epsilon$  is the temperature effectiveness.

Since the hot side air stream, i.e., the air stream exiting the dryer, contains more moisture which can condense, the cold airstream will have

a lower heat capacity, thus

$$C_{\min} = C_c = \dot{m}_c C_{p_c}$$

and in the case of no condensation

$$\dot{Q} = \epsilon C_c (T_{HS} - T_{CS}) = C_c (T_{CR} - T_{CS}) = C_h (T_{HS} - T_{HR})$$

thus

$$\epsilon = \frac{T_{CR} - T_{CS}}{T_{HS} - T_{CS}} = \frac{C_h}{C_c} \frac{T_{HS} - T_{HR}}{T_{HS} - T_{CS}} \quad (5)$$

For the case where the drying time is unchanged from that in the baseline operation mode (i.e., the same operating temperature), a new value for the heating element rating is obtained,

$$P_{HR} = \dot{m}_{air} (C_{p_{air}} + X_{\infty} C_{p_{H_2O}}) (T_{in} - T_{CR}) \quad (6)$$

where HR refers to the case with heat recovery. The temperature  $T_{CR}$  is calculated by equation (5) for a given heat exchanger effectiveness. With the operating temperatures calculated for the baseline experiments (see Appendix A), a heat exchanger effectiveness of 70%, and an increase in fan power of 100 W, we predict energy savings in the order of 30% (see Appendix B for numerical calculation).

In Chapter 2 we obtained the baseline operation costs for a clothes dryer of approximately \$100 per year. The savings will be approximately \$30 per year. The costs for the heat recovery equipment for a new design is estimated to be \$100 if the product is mass produced. This includes: an air-to-air heat exchanger core, one additional blower, additional ductwork, a more efficient lint filter (i.e. a fine nylon mesh), and improved seals around drying chamber and door. Assuming a real discount rate of 6%, the simple payback time will be approximately 4 years.

#### 4.2.3.2. Recirculation/Condensation Mode

A second arrangement to recover heat from the exhaust air with an air-to-air heat exchanger is a system where 100% of the air is recirculated through the dryer and the heat exchanger and a second open loop airstream is used to recover sensible and latent heat by cooling the dryer air and condensing the moisture contained in it. Room air is used for the open loop and the recovered heat is useful in the winter as space heat. This system does not need a vent and all exhaust heat is recovered. No moisture in the form of vapor is added to indoors. As mentioned before, a sufficient amount of room air must be available to maintain the required temperature gradient in the heat exchanger for the condensation process. Figure 5 is a schematic diagram of the dryer/heat exchanger configuration in the recirculation/condensation mode. The energy balances for the air-to-air heat exchanger with condensation are:

$$\dot{Q} = \epsilon C_{\min} (T_{HS} - T_{CS}).$$

The heat removed from the hot side air is approximately

$$\dot{Q}_h = \dot{m}_h (C_{p_h} + X_{out} C_{p_{H_2O}}) (T_{HS} - T_{HR}) + \dot{m}_{H_2O} h_{fg}(\bar{T}) \quad (7)$$

where  $\bar{T} = (T_{HS} + T_{HR})/2$  and  $\dot{m}_{H_2O}$  refers to the rate of condensation in the core of the heat exchanger.

The heat gain on the cold side is

$$\dot{Q}_c = C_c (T_{CR} - T_{CS}).$$

At steady state

$$\dot{Q}_h = \dot{Q}_c = \dot{Q} = \epsilon C_{\min} (T_{HS} - T_{CS}),$$

and

$$C_{\min} = C_c = \dot{m}_c C_{p_c}.$$

We obtain the relation between the heat exchanger effectiveness and the fluid properties,

$$\epsilon = \frac{T_{CR} - T_{CS}}{T_{HS} - T_{CS}} = \frac{\dot{m}_h (C_{p_h} + X_{out} C_{p_{H_2O}}) (T_{HS} - T_{HR}) + \dot{m}_{H_2O} h_{fg}(\bar{T})}{C_c (T_{HS} - T_{CS})}. \quad (8)$$

In this mode, operating temperatures and humidity loads will be the highest. A numerical calculation is not performed, since the drying kinetics are too complex for treatment here.

The above mentioned heat recovery modes can be incorporated into a clothes dryer equipped with an air-to-air heat exchanger and a summer/winter switch (preheating mode in the summer and recirculation/condensation mode in the winter). This will be discussed later.

#### 4.2.4 Recirculation With Condensation, Utilizing a Heat Pump

A third mode to recover both sensible and latent heat is recirculation of all the exhaust air back to the dryer while moisture is removed by a refrigeration-dehumidification process. No electric heating element is needed. The system functions as follows: the exhaust air of the dryer enters the evaporation coil of the dehumidifier where it cools down below the dewpoint, and sensible and latent heat are extracted. The heat is transferred to the condenser coil and reinjected back to the closed air cycle at a higher temperature level.

One problem is that maximum condenser temperature of existing refrigeration units is too low for this application, thus, long drying times result because the compressor cycles on and off due to a high temperature safety control. Figure 6 shows the schematic diagram of an integrated dryer/dehumidifier. Assuming, higher condenser temperatures around 80 °C are achievable without too low of a coefficient of performance (take COP = 2.5), a heat pump with a capacity of around 3 kW (10,000 Btu/h) could dry a standard load of clothes in 60 minutes. The reduction in dryer energy consumption is estimated to be 60% and, in addition, no heat is vented to outdoors. However, significant limitations of this approach are equipment costs, and maintenance and reliability considerations.

## 5. EXPERIMENTAL STUDY

The measurements were conducted at the Lawrence Berkeley Laboratory's Heat Exchanger Test Facility, located in Richmond, California.

### 5.1 Description of Experimental System and Test Procedure

The tested clothes dryer is a Speed Queen Model HE 5003 with a power rating of 5400 W at 240 V. Figure 7 shows a top and front view of the clothes dryer. The heating element is rated at 5000 W. The electric motor is rated  $\frac{1}{4}$  hp and the air flow rate is given as 173 cfm (4.9 m<sup>3</sup>/min). The drum volume is 5.75 ft<sup>3</sup> (163 l).

The general test procedure for each experiment consisted of measuring overall energy consumption, electric heater power input, amount of evaporated water, inlet and outlet temperatures, inlet and outlet humidities, temperature of the hot air after the heating element, air flow rates at inlet and outlet, and the drying cycle time including heating time and cool down time. The drying cycle was terminated manually.

The air flow rate was measured with pitot-tubes and micromanometers. Temperatures were measured with precision thermometers and/or copper-constantan thermocouples. Air humidities were determined using a lithium chloride humidity probe and with periodic wet-and dry- bulb temperature measurements using precision thermometers. The evaporation rate ( $m_{H_2O}$ ) was obtained by calculating the ratio of the amount of evaporated water (determined gravimetrically) to overall drying time. The tests were conducted with a standard load of test clothes containing 50% synthetic and 50% cotton fibers that weighed 7 lbs when dry. They were wetted to a

moisture content of 70% of the dry weight prior to each test. During the drying cycle, the moisture was reduced to approximately 3-5% of the bone-dry weight.<sup>1</sup> Electric power and energy were measured with a digital watt/watt-hour meter. The estimated accuracy of the measurements is discussed in Appendix D.

## 5.2. Test Results

The test results are described below and given in Tables 1-9 and Figures 8-12 and 14-15. Table 1 lists all tests performed and includes values for the three major parameters: electric heater voltage, air flow rate, and ambient temperature. Tables 2-7 present the reduced data for the experiments divided into seven categories: (1) baseline, (2) reduced air flow rate, (3) recirculation, (4) heat exchanger-preheat, (5) heat exchanger-recirculation/condensation, (6) dehumidifier, and (7) dehumidifier/heat exchanger. The reduced data includes the power consumption  $Q_{\text{corr}}$  (kWh) corrected for variations in ambient temperature and for estimated standard fan power ratings for the different test modes. In addition, the specific power consumption  $Q_{\text{spec}}$  (kWh/kg evaporated water) is given. Table 8 gives a comparison of experimental results with the theoretical calculation for the baseline. A comparison of all test modes in terms of energy savings is given in Table 9 and Figure 15.

### 5.2.1 Baseline Experiments

The baseline tests can be divided into five subseries as indicated in Table 1. The electric heater voltage was in the range of 115 to 230 V, which gives the range of the heater power of 1.25-4.55 kW. The air flow rate was approximately 120 cfm ( $3.4 \text{ m}^3/\text{min}$ ) which is significantly

less than the 173 cfm ( $4.9 \text{ m}^3/\text{min}$ ) reported by the manufacturer. The inlet temperature was either  $10 \text{ }^\circ\text{C}$  or  $20 \text{ }^\circ\text{C}$ . There were no restrictions at the inlet manifold and the air flow rate was measured at the outlet, where approximately 10 ft of 4-inch diameter ductwork was connected, including 2 elbows. A plastic sheet envelope was attached to the dryer housing to simulate tighter seals at dryer drum and door. A fine nylon mesh filter was installed in addition to the standard lint filter. The results are presented in Table 2.

The total drying time was approximately 40 min for the tests with 230 V ( $P_{\text{heater}} = 4.55 \text{ kW}$ , ambient temperature  $T_{\infty} = 20 \text{ }^\circ\text{C}$ ), which included a 2 min cool down time, (i.e., the cool down time was the period of time before termination of the cycle, during which the heater was turned off). The dryer's heating element cycled on and off near the end of the drying cycle due to exhaust air temperatures that exceeded the set point of a thermostat of approximately  $60 \text{ }^\circ\text{C}$ . The percentage of cycling time (period of time during which cycling of the heater occurs including the cool down time) relative to the total time ranged from 15 to 20%. The average evaporation rate for the cycle was approximately  $3.1 \text{ kg/h}$ . The tests with a lower inlet temperature ( $T_{\infty} = 10 \text{ }^\circ\text{C}$ ), simulating dryer operation in the unheated section of the house, lasted approximately 45 min and consumed about 13% more electricity. For tests with a reduced heater input ( $U = 190 \text{ to } 200 \text{ V}$ ,  $P_{\text{heater}} = 3.1 \text{ to } 3.45 \text{ kW}$ ), drying times increased to 52-60 min with insignificant energy savings. For a very low heater input ( $U = 115 \text{ V}$ ,  $P_{\text{heater}} = 1.25 \text{ kW}$ ), energy savings of about 5% were achieved but the drying times were unacceptably long (112 min instead of 40 min).

The comparison of experimental results with the theoretical calculation shows a good agreement (see Table 8). The measured temperature after the heating element was slightly higher than predicted due to a lower air flow rate. The exhaust air temperature was slightly lower than predicted due to heat losses to the surroundings, which were not taken into account in the theoretical calculation. Therefore, the measured evaporation rate was slightly lower than the predicted rate.

### 5.2.2 Experiments With Reduced Air Flow Rate

Tests were performed with reduced air flow rates and electric heater inputs as listed in Table 3. Drying times increased to 51-59 min compared to 40 min for the baseline. The percentage of cycling time to total time was 10 to 20%. The evaporation rate ranged from 2.22 to 2.53 kg/h (see Figure 14). Energy savings of approximately 8% were achieved, which means that the dryer is oversized for the standard load of 7 lbs of dry clothes. W.P. Levins<sup>10</sup> notes that according to a Procter and Gamble survey the weight of an average dryer load is even lower- only 5.4 lbs when dry.

When comparing tests with the same heater input but different air flow rates (compare tests B20 and B21 with B14 and B15), it can be seen that 5% energy savings can occur if the air flow rate is reduced from 120 cfm to approximately 83 cfm. This means that the effect of increase in drying temperatures, which results in faster drying kinetics, is greater than the opposite effect of reduced convection due to a lower air flow rate. Additional energy savings can be achieved with reduced air flow rates through a reduction in fan power and a decrease in the draft on the house.

### 5.2.3 Recirculation Experiments

For tests with recirculation, the voltage of the heating element was kept constant at 230 V, the air flow rate through the drying chamber was approximately 120 cfm and the ambient temperature was about 20 °C. The recirculated air was mixed with the fresh airstream prior to entering the heating element. To minimize the amount of recirculated lint, a fine nylon mesh filter was installed that is more effective than the standard lint filter. The recirculation ratio, defined as the amount of recirculated air divided by the total air flow rate, was adjusted with dampers at the inlet and outlet ducts. Three series of tests were performed with the recirculation ratio in the range of 49 to 72%. See Table 4 for test results. Due to the use of a second blower upstream of the dryer during the experiments, a slight pressurization of the drying chamber resulted, as compared to the baseline tests where the pull-through-blower instead depressurized the drying chamber. A mass balance calculation, considering the amount of evaporated water, the air flow rate at the outlet, and the humidity of the exhaust air, showed that approximately 8% of the removed moisture had leaked into the surrounding airspace.

The drying time for these tests was approximately 43 min with a variation of  $\pm 1.5$  min, which included a cool down time of 5 min. This drying time is not significantly more than the drying time for the baseline. The evaporation rate averaged 2.98 kg/h (see Figure 14). The percentage of cycling time equaled 41 to 48%, 60 to 65%, and about 70% for the tests with the recirculation ratio  $R = 49\%$ ,  $67\%$ , and  $72\%$ , respectively. An improved thermostat was installed (for these tests only), which controlled the exhaust air temperature within approximately  $\pm 4^{\circ}\text{C}$

during the cycling period. All other tests were performed with the standard thermostat which controlled the exhaust temperature within  $\pm 12^{\circ}\text{C}$ . Figure 8 shows a plot of the transient ambient temperature, inlet and outlet temperatures of the dryer air, and the temperature of the inlet air after being heated in the heating element, for the recirculation experiments and the baseline. It can be seen that with recirculation, the temperature in the drying chamber reaches its maximum of  $60^{\circ}\text{C}$  at an earlier time as compared to the baseline and therefore, the average exhaust temperature is higher and the cycling period is longer. Transient relative and absolute humidities of the airstream exiting the dryer are shown in Figures 10 and 11.

Energy savings are in the range of 10.4 to 18.5% depending on the recirculation ratio. This does not include potential savings due to a reduced draft in the house during dryer operation. The optimum recirculation ratio in terms of drying time, operating temperatures, and humidity loads is around 67% or in other words,  $2/3$  of the air is recirculated.

Simple calculations on the economics yield the following results. The costs for a retrofit of a typical residential clothes dryer with an accessible air inlet are about \$30. (Only some ductwork and an improved lint filter are required.) Here, we assume that the labor is performed by the homeowner at no costs. The simple payback time with a real discount rate of 6% and yearly energy savings of \$18 is a little less than two years.

#### 5.2.4 Heat Recovery Experiments

The heat exchanger used in these measurements is a Des Champs Model 74 counterflow heat exchanger with a heat transfer area of  $10.7 \text{ m}^2$  ( $115 \text{ ft}^2$ ). The effectiveness is about 70% with an air flow rate ranging from 80 to 160 cfm. The pressure drop is approximately  $0.26'' \text{ H}_2\text{O}$  at 120 cfm (for details see<sup>14</sup> pp. 37). An additional fan upstream of the heat exchanger provided equal flow rates on the inlet and outlet (i.e. minimized leakage at the dryer drum). The heat exchanger and associated ductwork was insulated with 3.5" thick foil-backed fiberglass insulation.

##### 5.2.4.1 Preheating Mode

For these tests, fresh air with a temperature of approximately  $10^\circ \text{C}$  was preheated with the exhaust air, which was vented outdoors. The voltages at the electric heater were 230 V and 115 V which yielded a heater power of approximately 4.5 kW and 1.25 kW, respectively. The air flow rate ranged from 115 to 118 cfm at the fresh air inlet of the heat exchanger (except test PH 4 where  $\dot{V}_{in} = 93 \text{ cfm}$ ). The pressure in the drying chamber was balanced with the ambient pressure by adjusting the exhaust air flow rate slightly. The test results are given in Table 5. The drying time was 39 to 40 min for the tests with 230 V including a 4 to 5 min cool down time. The heater cycled about 29 to 35% of the total drying time and the evaporation rate equaled approximately 3.2 kg/h (see Figure 14 for comparison). The energy savings when comparing with baseline tests B11 and B12 ( $T_{\infty} \sim 10^\circ \text{C}$ ) were about 26%. The heat exchanger effectiveness was approximately 60% and little condensation was observed. The fact that the heat exchanger effectiveness was lower than

estimated may explain why the actual energy savings were lower than the predicted savings of 30%. There appears to be a systematic error in the measurement of the temperature exiting the heat exchanger. In contrast to expectations, the temperature of the air exiting the exchanger was less than the measured temperature of air entering the dryer. The error may have been caused by a misplaced thermocouple that was in contact with the walls of the ducting. Another reason for the differences between predicted and measured energy savings was the different drying kinetics. For the theoretical calculation, the drying temperatures and times were assumed to be unchanged from baseline operation, and a new smaller power rating for the heating element was obtained. In the experiments, however, the power input of the heater was kept constant, which resulted in earlier cycling of the electric heater, and in faster drying. This mode of operation was expected to be slightly less energy efficient.

#### 5.2.4.2 Recirculation/Condensation Mode

For tests in the recirculation /condensation mode, the heater voltage was in the range of 190 to 230 V, the air flow rate of the closed dryer cycle was approximately 120 cfm (except test # HX7 where it was 85 cfm) and the flow rate of the of the air that passes in an open loop through the heat exchanger ranged from 125 to 128 cfm. Table 6 gives the results. The drying time was ranged from 60.5 to 65.0 min depending on the heater input. The electric heater cycled about 80% of the total drying time and the evaporation rate was approximately 2 kg/h (see Figure 14 for comparison). The energy consumption was 1.4 to 6.4% higher than the baseline energy consumption, depending on the electric heater

input. Approximately 75 to 80% of the removed water condensed in the heat exchanger-- the rest escaped to the surroundings due to the fact that the drying chamber was slightly pressurized. The heat exchanger effectiveness ranged from 70 to 80% and was higher than in the preheating mode due to increased latent heat recovery. The indoor air that was used as a heat sink to condense the moisture, is returned back to indoors as dry warm air at a temperature of 45 to 49 °C. With this arrangement, it is shown that sensible and latent waste heat can be recovered as useful space heat. Additional energy savings result from the fact that there is no increase in the infiltration rate of the house since there is no vent. Figure 9 shows transient operating temperatures including inlet and outlet temperatures of the heat exchanger, and compares them with the baseline. The heater starts cycling when the exhaust temperature reaches the maximum of 60 °C. In this figure  $T_{CR}$  is the cold return temperature of the heat exchanger (i.e., the temperature of the open loop airstream after passing through the heat exchanger). Figure 10 and 11 show transient relative and absolute humidities for various tests and indicate that the humidity of the airstream exiting the dryer is highest in the heat exchanger-recirculation mode of operation.

Based upon the test results, a brief calculation of the economics of a clothes dryer equipped with an air-to-air heat exchanger and a summer/winter switch (preheating mode in the summer and recirculation/condensation mode in the winter) is presented.

We assume, the clothes dryer is located in an electrically heated house, the heating season lasts 5 months, and heat losses from the

clothes dryer housing to the surroundings are negligible. Furthermore, the increase in energy consumption during the HX-recirculation/condensation mode is assumed negligible.

The costs of the new equipment is estimated to be \$100 (see Chapter 4.2.3.1). With 25% heat recovery in the summer and 100% heat recovery in the winter, the savings will be approximately \$56/year. Assuming a real discount rate of 6%, the simple payback time will be approximately 2 years.

Tests were performed to show the drying kinetics and to compare them with the baseline. The clothes were periodically removed from the dryer and weighed to provide information on the rate of evaporation versus time. It is expected that the periodic interruption of the drying process affected the results, but the trends observed should still be representative. The drying rate, which is defined as the mass of evaporated water divided by the mass of the dry clothes is plotted over time and shown in Figure 12. The graphs can be divided into two parts, the warm-up period (after which the drying rate reaches its maximum) and the drying period, during which the drying rate drops down continuously to approximately 1/10 of the maximum. As long as capillary action is sufficient to transport water from the inside of the clothes to the surface, the drying rate is at its maximum which depends on the temperature and humidity of the air, and the heat and mass transfer coefficients at the interface. However, as the moisture content of the clothes is reduced further, the drying rate decreases as a result of reduced heat transfer to the inside wet layer of the clothes and the resistance to water vapor diffusion within the clothes.

### 5.2.5 Experiments with a Heat Pump

The heat pump used for the experiments is a White Westinghouse residential dehumidifier Model ED 358 with a rated condensation capacity of 35 pints/day (0.69 l/hr) at American Home Appliance Manufacturers (AHAM) standard conditions ( $T_{\infty} = 80^{\circ}\text{F}$ ,  $\text{RH}_{\infty} = 60\%$ ). This corresponds to a refrigeration load of approximately 6500 Btu/h (1.9 kW). The coefficient of performance is approximately equal to 2.5. The refrigerant used is R500.

Four tests were performed, one with the dehumidifier alone (Test #D5) and three tests with a dehumidifier and an air-to-air heat exchanger in series (Tests # DH1, DH2, and DH3). The heat exchanger was positioned upstream of the dehumidifier and its function was to remove part of the sensible heat contained in the exhaust air. The test results are presented in Table 7. The average power input of the compressor was in the range of 650 to 850 W, the flow rate of the closed loop drying cycle was about 130 cfm for the tests with a heat exchanger and approximately 180 cfm when the heat exchanger was not used. The flow rate of the cooling air through the heat exchanger ranged from 36 to 113 cfm. The drying time ranged from 120 to 150 min. For test #D5, the compressor started cycling on and off after a short warm-up period until the end of the cycle due to thermal overloading. The percentage of cycling time was 85% of the total time. For the other tests, the flow rate of the open cooling air cycle was adjusted so that no or very little cycling occurred. This reduced the drying time from 150 min to 120 min. The evaporation rate was in the range of 0.85 to 1.00 kg/h (see Figure 14). The drying cycle with the dehumidifier and no heat exchanger (test # D5)

consumed about 33% less energy than the baseline, although it lasted approximately 3.75 times as long. The drying cycle with the additional heat exchanger and a low flow rate of cooling air (test # DH3) consumed about 29% less energy and lasted 3 times longer compared to the baseline.

These tests show that a significant potential in energy savings exists, however, the dehumidifier has to be redesigned so that it will operate at higher condenser temperatures. As an example the compressor could be modified and refrigerant R114 could be used instead of R500. Another arrangement to improve the condensation performance and therefore reduce drying times is to remove part of the sensible heat in an air-to-air heat exchanger, condensing the moisture at the evaporator of the heat pump, and then preheating the air in the heat exchanger before it heats up to the maximum temperature at the condenser of the heat pump. This arrangement is shown in Figure 13. No tests of this configuration were performed.

## 6. SUMMARY AND RECOMMENDATIONS

A literature review on energy efficient clothes dryers was performed, which identified a number of technical improvements and various energy saving techniques. A summary of these measures is given in Table 10.

A theoretical analysis was presented that describes the drying process and predicts the amount of energy savings when an air-to-air heat exchanger is utilized for heat recovery.

The four basic energy saving techniques that were studied experimentally are (1) reduced air flow rate; (2) recirculation of exhaust air; (3) heat recovery, utilizing an air-to-air heat exchanger; and (4) recirculation with condensation, utilizing a heat pump. The results are presented in Table 9 and Figure 15.

Baseline tests show that the actual air flow rate was smaller than reported by the manufacturer. About half of the heat contained in the exhaust air appeared as sensible heat. It was found that about 8% energy savings could be achieved by matching air flow rate and heater input to the size of the dryer load. This could be achieved with a variable electric heater and a multiple speed motor for the fan.

Recirculation of exhaust air resulted in a 10-18% decrease in energy consumption, depending on the recirculation ratio. The latter is suggested to be around 67%. The costs for retrofits are low and payback times can be as short as two years if the labor is performed by the homeowner. This energy saving measure could be incorporated into new equipment by the manufacturers.

A 26% reduction in energy consumption was achieved with heat recovery, utilizing an air-to-air heat exchanger in the preheating mode and the dryer being operated in the unheated section of the house. Little latent heat was recovered. High equipment costs (approximately \$100) yield an estimated payback time of four years for this energy saving measure. However, 100% heat recovery can be achieved by using an air-to-air heat exchanger, when the exhaust air is 100% recirculated and the moisture condensed, using indoor air as a heat sink. This arrangement represents a closed system with no vent and the exhaust heat is

utilized as useful space heat in the winter. Therefore, a clothes dryer equipped with an air-to-air heat exchanger and a summer/winter switch (preheating mode in the summer and recirculation/condensation mode in the winter) is a potential candidate for an energy efficient appliance. The energy savings averaged over a year with a 5 month heating season amount to approximately \$56/year and the payback time will be approximately 2 years. The development of such an appliance should be pursued by the manufacturers.

The last experiments were performed using a heat pump. A residential dehumidifier was coupled to a clothes dryer and this integration resulted again in a closed system with 100% heat recovery. Tests show a 33% reduction in energy consumption, however the drying time is unacceptably long (approximately 150 min or 3.75 x baseline time). Because currently available dehumidification systems are not designed for operation at higher temperatures, the dehumidifier overheats and periodically cycles off during the drying process. Further development is needed to design a dehumidifier for the drying process.

An alternative approach to thermal clothes drying is vacuum drying. A suitable device for this process is a water ring air pump which can produce vacuums as low as 3" Hg absolute, and still have a high flow rate. In addition, there are no problems with water vapor carry-over. In fact, water vapor condenses in such a pump, thus reducing the volume to be handled and increasing the pump's capacity. The latent heat of evaporation is recovered in a liquid-to-air heat exchanger adjacent to the pump. The saturated air/water mixture enters a separator, the air is expanded in an expansion valve, passes through the heat exchanger where

it is heated and then recirculated back into the drying chamber. This arrangement represents a closed system with no vent and is shown in Figure 16.

If a water ring pump is used, the drying chamber could be a sealed rotating drum or a simple drying cabinet without the clothes being tumbled. The electric heating element is needed only in the beginning of the cycle to heat up the clothes in order to reach a reasonably high partial water vapor pressure. Preliminary calculations yield a power consumption of approximately 1.5 kWh for a standard drying cycle which will last approximately 60 min. (electric heat and pump-down time not included), using a 1 HP water-ring air pump with a capacity of 20 cfm at 6" Hg absolute. (A standard thermal drying cycle consumes 3 kWh and lasts 40 min.). At the present time water-ring pumps are not readily available at costs that would make this system attractive (only heavy duty industrial pumps are available).

Summarizing, it can be said that significant energy savings could result from the various energy saving measures investigated. However, in addition to further laboratory work, a better understanding of factors such as the cost, marketability, reliability and consumer acceptance of various measures is desirable.

## ACKNOWLEDGEMENTS

The authors wish to thank Arthur H. Rosenfeld who initiated this work. The help of Brenton F. Stearns in general and in particular on the interaction of a clothes dryer and the indoor environment is gratefully acknowledged. James Koonce and Lloyd Davis assisted in many aspects of the experimental work. Special thanks to Ray Chant, Francis Offermann, and Brenton Stearns who reviewed the report. Gayle Milligan, Nancy Morrision, Jeana Traynor and Ruth Williams typed the various drafts and the final manuscript. We would also like to thank Moya Melody for supervising the preparation of the figures.

This work was supported by the Assistant Secretary of Conservation and Renewable Energy, Office of Building Energy Research and Development, Building Systems Division of the U.S. Department of Energy under Contract No. DE-AC03-76SF00098.

## REFERENCES

1. Consumer Products Efficiency Standards, Engineering Analysis Document, U.S. Department of Energy, DOE/CE-0030, March 1982.
2. Residential Electric Laundry Dryer Load Research Project, (Pacific Gas and Electric Company, San Francisco, California), December 1965.
3. Electric Clothes Dryer Energy Consumption, Field Study, Oklahoma Gas and Electric, 1971.
4. J.J. Angelone, U.S. Pat. No. 3,157,391 (issued 1964).
5. Frank H. Winstel, U.S. Pat. No. 4,028,817 (filed 1975).
6. B. Walsh, "Technical Background Information for Appliance Efficiency Targets for Clothes Dryers," Federal Energy Agency Draft, April 1976.
7. D.L. Hodgett, "Improving the Efficiency of Drying Using Heat Pumps," Electricity Council Research Centre, Capenhurst (England), August 1976.
8. Andrew J. Fowell, "Clothes Dryer Air Exchange," Proceedings of the Conference on Major Home Appliance Technology for Energy Conservations, Purdue University, West Lafayette, Indiana 47907, February 27-March 1, 1978.
9. Odean F. George, U.S. Pat. No. 4,275,510 (filed 1979).
10. W.P. Levins, "Energy and the Laundry Process," Oak Ridge National Laboratory, ORNL/CON-41, Oak Ridge, Tennessee 37830, April 1980.

11. "Reducing Energy Costs in Nursing Homes," American Health Care Association, Washington, DC 20005, 1981.
12. K.T. Feldman, Jr. and G.J. Tsai, "The Potential for Domestic Heat Recovery," New Mexico Energy Research and Development Institute, Albuquerque, New Mexico 87131, November 1981.
13. T. Kevin Murphy and Steve Greenberg, "Preliminary Study for University Village Laundry Solar Conversion," University of California Berkeley, Appropriate Technology Program, Berkeley, California 94720, December 1981.
14. William J. Fisk, Gary D. Roseme, and Craig D. Hollowell, "Performance of Residential Air-to-Air Heat Exchangers: Test Methods and Results," Lawrence Berkeley Laboratory, Report LBL-11793, Berkeley, California 94720, September 1980.

APPENDIX A: Numerical Calculation for the Baseline

The calculation is based on the operation data of a typical commercially available electrical residential clothes dryer (Speed Queen Model HE5003), typical indoor air temperature and humidity and an evaporation rate, which is obtained from previous studies.<sup>6</sup> We can summarize the given parameters as follows:

$$\begin{aligned} P &= 4.55 \text{ kW at } 230 \text{ V} \\ P_{\text{fan}} &= 0.25 \text{ kW at } 230 \text{ V} \\ \dot{V}_{\text{air}} &= 120 \text{ cfm} = 3.4 \text{ m}^3/\text{min} \\ T_{\infty} &= 68 \text{ }^{\circ}\text{F} = 20 \text{ }^{\circ}\text{C} \\ \text{RH}_{\infty} &= 55\% \\ \dot{m}_{\text{H}_2\text{O}} &= 3.5 \text{ kg/h} \\ (\dot{m}_{\text{H}_2\text{O}} &= 2.1 \text{ kg, } t_{\text{heat}} = 36 \text{ min}) \end{aligned}$$

Equations (1), (2a), and (2b) yield the values for the average operating temperature and absolute humidity of the exhaust air. The relative humidity is obtained from the psychrometric chart. We obtain

$$\dot{m}_{\text{air}} = \rho_{\text{air}} \dot{V}_{\text{air}} = 4.044 \text{ kg/min}$$

$$\text{with } \rho_{\text{air}} = 1.19 \text{ kg/m}^3 \text{ at } 20 \text{ }^{\circ}\text{C},$$

$$X_{\infty} = 0.008 \frac{\text{kgH}_2\text{O}}{\text{kg dry air}}$$

$$\bar{X}_{out} = X_{\infty} + \frac{\dot{m}_{H_2O}}{\dot{m}_{air}} \quad (1)$$

$$\rightarrow \bar{X}_{out} = 0.0224 \frac{\text{kgH}_2\text{O}}{\text{kg dry air}}$$

$$\bar{T}_{in} = T_{\infty} + \frac{P}{\dot{m}_{air} (C_{p,air} + X_{\infty} C_{p,H_2O})} \quad (2a)$$

The properties of water vapor and air are given as:

$$C_{p,H_2O} \Big|_{20^{\circ}\text{C}}^{80^{\circ}\text{C}} = 1.91 \frac{\text{kJ}}{\text{kgK}}$$

$$C_{p,air} \Big|_{20^{\circ}\text{C}}^{80^{\circ}\text{C}} = 1.009 \frac{\text{kJ}}{\text{kgK}}$$

$$h_{fg}(68^{\circ}\text{C}) = 2334 \frac{\text{kJ}}{\text{kg}}$$

$$\rightarrow \bar{T}_{in} = 85.9^{\circ}\text{C}$$

$$\bar{T}_{out} = \frac{\dot{m}_{air} (C_{p,air} + X_{\infty} C_{p,H_2O}) T_{in} + \dot{m}_{H_2O} (C_{p,H_2O}(\bar{T}) \bar{T} - h_{fg})}{\dot{m}_{air} (C_{p,air} + X_{out} C_{p,H_2O})} \quad (2b)$$

We assume  $T_{out} = 50 \text{ }^{\circ}\text{C} \rightarrow \bar{T} = 68 \text{ }^{\circ}\text{C}$

$$\bar{T}_{out} = 53.4 \text{ }^{\circ}\text{C}$$

From the psychrometric chart, we get

$$\bar{RH}_{out} = 25\%$$

The fan heat and cool down time are neglected in this calculation.

The sensible heat gain is calculated from equation (3), assuming that the exhaust air is cooled down to room temperature  $T_{\infty}$ .

$$\dot{Q}_{sens} = \dot{m}_{air} (C_{p,air} + X_{out} C_{p,H_2O}) (T_{out} - T_{\infty}) \quad (3)$$

$$\rightarrow \underline{\dot{Q}_{sens} = 2.368 \text{ kW}}$$

The percentage of sensible heat is calculated by

$$\frac{\dot{Q}_{sens}}{P} = \frac{2.368}{4.550} = 52.0\%$$

The overall power consumption is

$$Q_{tot} = P_{heat} + P_{fan} t_{tot}$$

$$t_{tot} = t_{heat} + t_{cooldown}$$

$$t_{\text{cooldown}} = 5 \text{ min}$$

$$\rightarrow \underline{Q_{\text{tot}} = 2.9 \text{ kWh} .}$$

APPENDIX B: Numerical Calculation for Heat Recovery, Utilizing an Air-to-Air Heat Exchanger in the Preheating Mode

We take the same input parameters as used in the baseline calculation, except the fan power which is slightly higher, and assume a heat exchanger effectiveness of 70%. We can summarize the given parameters as follows:

$$\begin{aligned} P &= 4.55 \text{ kW at } 230 \text{ V} \\ P_{\text{fans}} &= 0.35 \text{ kW at } 230 \text{ V} \\ V_{\text{air}} &= 120 \text{ cfm} = 3.4 \text{ m}^3/\text{min} \\ T_{\infty} &= 68 \text{ }^{\circ}\text{F} = 20 \text{ }^{\circ}\text{C} \\ RH_{\infty} &= 55\% \\ \dot{m}_{\text{H}_2\text{O}} &= 3.5 \text{ kg/h} \\ \epsilon_{\text{HX}} &= 0.7 \end{aligned}$$

Equations (5) and (6) (see Chapter 4.2.3.1) yield the cold return temperature and the amount of electrical power needed to heat up the preheated air:

$$\underline{T_{\text{CR}} = 43.4 \text{ }^{\circ}\text{C}}$$

$$\underline{P_{\text{HR}} = 2.934 \text{ kW}}$$

The amount of energy savings is calculated as follows:

$$Q_{\text{HR}} = P_{\text{HR}} t_{\text{heat}} + P_{\text{fans}} t_{\text{tot}}$$

$$t_{\text{heat}} = 36 \text{ min}$$

$$t_{\text{cooldown}} = 5 \text{ min}$$

$$t_{\text{tot}} = 41 \text{ min}$$

$$\rightarrow \underline{Q_{\text{HR}} = 2.00 \text{ kWh}}$$

$$\underline{\text{Energy Savings}} = \frac{Q_{\text{baseline}} - Q_{\text{HR}}}{Q_{\text{baseline}}} = \underline{31\%}$$

APPENDIX C: Increase of Infiltration Rate During Clothes Dryer Operation.

It is mentioned earlier that during clothes dryer operation the infiltration rate in a house does not increase proportionally to the venting rate of the clothes dryer. This can be shown qualitatively in a simple model.

We assume, a house is symmetrical and the natural infiltration rate (including wind and stack effects) is greater than the forced infiltration rate (i.e. due to an exhaust ventilation system, etc.). We also assume that the infiltration and exfiltration curves are symmetrical depending on the pressure difference in the house. This is shown in Figure 17. During dryer operation, the pressure difference in the house is shifted from equilibrium to the negative pressure difference  $\Delta p_f$  due to forced ventilation, according to the dryer venting rate  $V_f$ . It can be seen that the infiltration rate is only increased by  $\Delta V$  which is less than half of  $V_f$ .

#### APPENDIX D: Accuracy of Measurements and Reproducibility

In this chapter, the accuracy of specific measurements as well as the variations of ambient and operating conditions are discussed.

Temperature Measurements: Airstream temperatures were measured with copper-constantan thermocouples and precision thermometers. The latter have a measurement uncertainty of  $\pm 0.1$  °C while the thermocouple system in conjunction with a discontinuous 16 channel strip chart recorder has an estimated maximum error of about  $\pm 1$  °C. Additional errors may appear because of stratified flow patterns and uneven temperature profiles in the ducts. To overcome this source of errors, air mixers were installed in the ducts and several thermocouples were used at different locations. The temperature of the inlet air after being heated in the heating element was measured with a shielded thermometer and a thermocouple but errors due to radiation heat gains are still possible.

Air Flow Measurements: The air flow rates were measured with pitot tubes and micromanometers. The pitot tubes were located at the center of circular 4" ducts and a multiplicative correction factor of 0.9 was used to determine the average air velocity from the centerline velocity.

The accuracy of the air flow rate measurements depends mainly upon the flow profile in the ducts (i.e., the correction factor of 0.9 is based on the assumption of a smooth profile) and upon the accuracy of the pressure difference measurements. The uncertainty of the micromanometers is estimated to be  $\pm 0.002$  " H<sub>2</sub>O. This gives an approximate error range for flow rate between 38 and 180 cfm of 5 to 7%.

Electric Power Consumption Measurements: Power and energy consumption were measured with a digital watt/watt-hour meter and the measurement error is estimated to be less than 1% based on the manufacturer's product literature.

Mass Measurements: The energy consumption and drying time depend greatly on the amount of residual moisture in the clothes and accurate measurements are desirable. A double beam scale was used with an accuracy of  $\pm 1$  oz (28.35 g) which gives a maximum error of about 1% in the amount of evaporated water.

Humidity Measurements: The lithium-chloride dew point humidity probe has a long response time and thus does not track the humidity if it changes rapidly which is the case during a drying cycle. Therefore care should be taken when analyzing the humidity measurements. A calibration of the probe was performed by comparison to a more accurate (chilled mirror based) dew point instrument and the agreement between the two instrument, was very good; however, the calibration was performed with very steady humidities.

Ambient air characteristics varied during the drying cycles, thus hampering the reproducibility of the tests. The ambient air temperature varied about  $\pm 3$  °C and the relative humidity ranged from 30 to 67%. Although, for comparison, the measured energy consumption was corrected for variations in ambient air temperatures for the different test modes (see footnotes of tables). The corrected energy consumption was then divided by the amount of evaporated water and a specific energy consumption is obtained. The amount of energy savings was calculated from the specific energy consumption.

It should be noted that for the heat recovery tests using an air-to-air heat exchanger or a heat pump, significant uncertainties exist with the determination of the amount of condensed water in the heat exchanger core or coils because of possible water storage. In case of the test runs specifically to study the drying kinetics tests, the measurement procedure of repeatedly weighing the clothes after certain time intervals (i.e. 10 min) influenced the drying process and added some uncertainty to the validity of these tests.

Table 1. Summary of Tests  
 (values are averaged, total number of tests: 47)

Mode	U(V)	$\dot{V}$ (cfm)	$T_{\infty}$ ( $^{\circ}$ C)	
1. Baseline				
B4, 5, 6, 7, 13	230	120	20	
B8, 9	115	120	20	
B10, 11, 12	230	120	10	
B 19	190	120	20	
B20, 21	200	120	20	
2. Reduced Air Flow Rate				
B14, 15	200	83	20	
B16, 17, 18	190	63	20	
3. Recirculation				
RC2, 3	230	120	20	recirculation ratio R = 49%
RC4, 5, 6	230	120	20	recirculation ratio R = 67%
RC7	230	120	20	recirculation ratio R = 72%
4. HX-Preheat				
PH1, 2, 3, 5	230	120	10	
PH4	230	100	4	
PH6, 7	230	120	8	
5. HX-Recirculation				
HX1, 2, 3, 8	230	120	20	
HX4	200	120	20	
HX5, 6	190	120	20	
HX7	230	85	20	
6. Dehumidifier				
D5	115	180	20	
7. Dehumidifier-HX				
DH1, 2, 3	115	130	20	
8. Kinetics				
Baseline BML, 2	230	120	20	
HX-Recirculation HXML, 2	230	120	20	

Table 2. Baseline Tests

Test #	U (V)	P <sub>heater</sub> (kW)	P <sub>fan</sub> (kW)	V <sub>air</sub> (cfm)	T <sub>∞</sub> (°C)	RH <sub>∞</sub> (%)	T <sub>heater</sub> (°C)	T <sub>out</sub> (°C)	t (min)	t <sub>cool down</sub> (min)	Q (kWh)	Q <sub>corr</sub> (kWh)	m <sub>H<sub>2</sub>O</sub> (kg)	m <sub>H<sub>2</sub>O</sub> (kg/h)	Q <sub>spec</sub> (kWh/kg)
B4	235	4.65	0.25	116	21.5	55	91.0	51.0	40.70	2	2.920	2.987	2.10	3.10	1.423
B5	235	4.67	0.25	117	21.5	53	92.5	50.5	39.36	2	2.976	3.041	2.07	3.14	1.468
B6	230	4.55	0.25	120	21.5	57	91.0	48.5	40.70	2	2.986	3.055	2.13	3.14	1.436
B7	230	4.53	0.25	118	21.5	58	88.0	49.0	40.00	2	2.926	2.993	2.07	3.11	1.445
B8	115	1.25	0.25	117	20.5	58	39.5	29.5	112.0	0	2.827	2.889	2.10	1.13	1.395
B9	115	1.25	0.25	116	20.0	66	39.0	29.0	112.0	0	2.831	2.831	2.10	1.13	1.348
B10	230	4.55	0.40	121	11.5	44	63.0	41.5	45.50	2	3.604	3.401	2.13	2.81	1.598
B11	230	4.51	0.25	117	10.0	36	77.0	43.5	44.0	2	3.348	3.348	2.07	2.82	1.617
B12	230	4.50	0.25	120	10.0	50	73.2	43.0	45.00	2	3.440	3.440	2.10	2.80	1.639
B13	230	4.57	0.24	136	21	47	83	47.3	40.10	2	2.985	3.043	2.10	3.14	1.449
E19	190	3.11	0.25	119	18.5	62	62	38.5	60.0	5	3.163	3.062	2.10	2.10	1.458
B20	200	3.45	0.25	116	20	42	60	40	53.5	2.5	2.900	2.900	2.07	2.32	1.401
B21	200	3.46	0.24	118	21	38	62.5	42	52.0	5	2.946	3.0125	2.10	2.42	1.435

T<sub>∞</sub> standard = 20°C/ 10°  
P<sub>fan</sub> standard = 0.25 kW

Table 3. Reduced Air Flow Rate Tests

Test #	U (V)	P <sub>heater</sub> (kW)	P <sub>fan</sub> (kW)	V <sub>air</sub> (cfm)	T <sub>∞</sub> (°C)	RH <sub>∞</sub> (%)	T <sub>heater</sub> (°C)	T <sub>out</sub> (°C)	t (min)	t <sub>cool down</sub> (min)	Q (kWh)	Q <sub>corr</sub> (kWh)	m <sub>H<sub>2</sub>O</sub> (kg)	m <sub>H<sub>2</sub>O</sub> (kg/h)	Q <sub>spec</sub> (kWh/kg)
B14	200	3.40	0.23	85	20	54	91.3	47.5	54.60	5	2.951	2.969	2.18	2.40	1.359
B15	200	3.43	0.245	81.7	19.5	58	94	45.5	50.57	5	2.869	2.854	2.13	2.53	1.341
B16	190	3.10	0.23	63	20	54	110	47	59	5	2.869	2.916	2.18	2.22	1.335
B17	190	3.08	0.23	63	20.5	47.5	113	47	56.07	5	2.691	2.726	2.18	2.34	1.248
B18	190	3.08	0.23	62	19	66.7	113	45.5	55.40	5	2.860	2.846	2.13	2.31	1.337

T<sub>∞</sub> standard = 20°C

P<sub>fan</sub> standard = 0.25 kW

Table 4. Recirculation Tests

Test #	RC2	RC3	RC4	RC5	RC6	RC7
U (V)	230	230	230	230	230	230
P <sub>heater</sub> (kW)	4.50	4.51	4.51	4.50	4.51	4.51
P <sub>fan</sub> (kW)	0.245	0.245	0.245	0.245	0.245	0.245
V <sub>out</sub> (cfm)	118	118.5	115	117	115	113.5
V <sub>Ex</sub> (cfm)	63	63	38	39	39	32
V <sub>in</sub> (cfm)	58	58	38	38	38	31
T <sub>∞</sub> (°C)	22.5	21.5	23	24.5	22	23
RH <sub>∞</sub> (%)	52	43	44	31	31	34
$\bar{T}_{mix}$ (°C)	31	34.5	43	-	42.5	45.5
$\bar{T}_{out}$ (°C)	53.5	53.5	55.5	-	55.5	56
$\bar{T}_{heater}$ (°C)	84.5	83	86	-	86.5	85
t (min)	42.52	41.6	43.0	45.0	42.52	44.4
t <sub>cool down</sub> (min)	5	5	5	2.5	5	5
R (%)	49	49	67	67	66.5	72
Q (kWh)	2.654	2.679	2.443	2.524	2.453	2.396
Q <sub>corr</sub> (kWh)	2.716	2.717	2.493	2.600	2.487	2.438
m <sub>H<sub>2</sub>O</sub> (kg)	2.10	2.10	2.10	2.10	2.10	2.07
$\dot{m}_{H_2O}$ (kg/h)	2.96	3.03	2.93	2.80	2.96	2.80
Q <sub>spec</sub> (kWh/kg)	1.294	1.29	1.187	1.238	1.185	1.177

T<sub>∞</sub> standard = 20°C  
P<sub>fan</sub> standard = 0.25 kW

Table 5. HX-Preheat Tests

Test #	PH1	PH2	PH3	PH4	PH5	PH6	PH7
U (V)	230	230	230	230	230	115	115
P <sub>heater</sub> (kW)	4.51	4.51	4.51	4.52	4.52	1.25	1.25
P <sub>fan</sub> (kW)	0.25	0.25	0.25	0.25	0.25	0.25	0.25
V <sub>in</sub> (cfm)	118	117	117	116	93	115	116.5
V <sub>out</sub> (cfm)	113	109	110	113.5	107	113	114
$\bar{T}_{CR_2}$ (°C)	34.5	32.5	33.0	31.5	32.7	20.5	18.0
$\bar{T}_{heater}$ (°C)	83.0	80	83.5	79.0	82.7	34.5	34.0
$\bar{T}_{HS}$ (°C)	49.5	47.5	49.0	46.5	48.2	27.5	24.0
$\bar{T}_{HR}$ (°C)	25.7	26.0	26.2	25.5	25.5	16.5	15.0
T <sub>CS</sub> (°C)	11.0	9.0	9.5	7.0	4.0	8.0	7.0
$\bar{T}_{CR_1}^*$ (°C)	31.5	30.0	32.0	29.5	30.2	19.0	16.5
t (min)	40.0	39.5	39.4	39.0	40.1	110.0	100.0
t <sub>cool down</sub> (min)	5	5	4	4	4	0	0
Q (kWh)	2.547	2.510	2.589	2.587	2.647	2.763	2.534
Q <sub>corr</sub> (kWh)	2.614	2.444	2.523	2.522	2.580	2.946	2.700
m <sub>H<sub>2</sub>O</sub> (kg)	2.13	2.10	2.13	2.09	2.16	2.19	2.10
$\dot{m}_{H_2O}$ (kg/h)	3.19	3.19	3.24	3.29	3.23	1.19	1.26
$\epsilon_{HX}$ (%)	61.0	61.0	59.5	62.0	64.9	64.1	64.7
Q <sub>spec</sub> (kWh/kg)	1.228	1.164	1.186	1.210	1.194	1.348	1.286

$T_{\infty}$  standard = 10°C

P<sub>fan</sub> standard = 0.35 kW

$\epsilon_{HX}$  = heat exchanger effectiveness

\* See text regarding error in  $\bar{T}_{CR_1}$  for these tests.

Table 6. HX-Recirculation Tests

Test #	HX1	HX2	HX3	HX4	HX5	HX6	HX7	HX8
U (V)	230	230	230	200	190	190	230	230
P <sub>heater</sub> (kW)	4.54	4.54	4.54	3.50	3.15	3.15	4.56	4.57
P <sub>fan</sub> (kW)	0.26	0.27	0.27	0.26	0.26	0.25	0.25	0.26
V <sub>RC</sub> (cfm)	121	120	120	120	122	121	85	124
V <sub>open</sub> (cfm)	128	128.5	125	127	127	127	127	127
T <sub>HR2</sub> (°C)	40.0	40.0	41.5	42.5	40.3	40.0	39.5	40.0
T <sub>heater</sub> (°C)	74.5	75.0	74.5	73.0	71.0	69.3	82.0	72.0
T <sub>HS</sub> (°C)	55.0	55.0	55.5	54.5	53.7	52.5	55.5	54.0
T <sub>HR1</sub> (°C)	42.0	42.5	43.5	45.0	43.0	42.2	42.2	42.0
T <sub>CS</sub> (°C)	21.5	19.0	20.5	22.5	21.0	21.5	21.0	20.0
T <sub>CR</sub> (°C)	45.0	46.0	48.0	49.0	47.0	46.2	46.2	46.8
t (min)	60.90	60.19	60.22	63.50	63.00	63.00	65.00	60.50
t <sub>cool down</sub> (min)	2	2	2	3	5	5	5	5
Q (kWh)	3.217	3.209	3.116	2.908	3.008	3.009	3.014	3.114
Q <sub>corr</sub> (kWh)	3.308	3.289	3.196	3.003	3.103	3.114	3.119	3.205
m <sub>H2O</sub> (kg)	2.13	2.13	2.11	2.10	2.10	2.10	2.13	2.09
m <sub>H2O</sub> (kg/h)	2.10	2.12	2.11	1.98	2.00	2.00	1.96	2.07
ε <sub>HX</sub> (%)	70.1	75.0	78.6	82.8	79.5	79.7	73.0	78.8
Q <sub>spec</sub> (kWh/kg)	1.554	1.545	1.512	1.430	1.478	1.483	1.465	1.537

P<sub>fan standard</sub> = 0.35 kW

Table 7. Dehumidifier (D) and Dehumidifer/HX (DH) Tests

Test #	D5	DH1	DH2	DH3
U (V)	115	115	115	115
$P_{\text{compr}}$ (kW)	0.837	0.655	0.675	0.745
$P_{\text{fans}}$ (kW)	0.500	0.645	0.645	0.645
$V_{\text{RC}}$ (cfm)	180	129	132	130
$V_{\text{open}}$ (cfm)	--	113	56	36
$T_{\text{CS}}$ ( $^{\circ}\text{C}$ )	20.4	19.5	18.0	21.0
$\text{RH}_{\infty}$ ( $^{\circ}\text{C}$ )	53	58	57	57
$\bar{T}_{\text{in}}$ ( $^{\circ}\text{C}$ )	43.0	35.5	38.5	43.5
$\bar{T}_{\text{HS}}$ ( $^{\circ}\text{C}$ )	36.5	29.5	31.5	34.0
$T_{\text{HR}}$ ( $^{\circ}\text{C}$ )	--	24	27.5	31.5
$\bar{T}_{\text{CR}}$ ( $^{\circ}\text{C}$ )	--	26	29	32
t (min)	151	143	130	119
$t_{\text{cooldown}}$ (min)	0	0	0	0
Q (kWh)	2.594	3.100	2.869	2.677
$Q_{\text{corr}}$ (kWh)	2.091	2.516	2.338	2.191
$m_{\text{H}_2\text{O}}$ (kg)	2.16	2.07	2.04	2.04
$\dot{m}_{\text{H}_2\text{O}}$ (kg/h)	0.86	0.87	0.94	1.03
$\epsilon_{\text{HX}}$ (%)	--	65.0	81.5	84.6
$Q_{\text{spec}}$ (kWh/kg)	0.970	1.215	1.145	1.024

$P_{\text{fan standard}}$  (D5) = 0.3 kW

$P_{\text{fan standard}}$  (DH) = 0.4 kW

Table 8. Comparison of Experimental Results With the  
Theoretical Calculations for the Baseline

<u>Input Data</u>	Theoretical Calculation	Experiments*
$P_{\text{electr}}$ (kW)	4.55	4.55
$P_{\text{fan}}$ (kW)	0.25	0.25
$\dot{V}_{\text{air}}$ (cfm)	120	118
$T_{\infty}$ (°C)	20	20
$RH_{\infty}$ (%)	55	55
$X_{\infty}$ $\left[ \frac{\text{kgH}_2\text{O}}{\text{kg dry air}} \right]$	0.008	0.008
$\dot{m}_{\text{H}_2\text{O}}$ (kg/h)	3.5	--
<hr/>		
<u>Results</u>		
$T_{\text{heater}}$ (°C)	85.9	90.0
$T_{\text{out}}$ (°C)	53.4	50.0
$RH_{\text{out}}$ (%)	25	31.6**
$X_{\text{out}}$ $\left[ \frac{\text{kgH}_2\text{O}}{\text{kg dry air}} \right]$	0.0224	0.0210**
$\dot{m}_{\text{H}_2\text{O}}$ (kg/h)	--	3.1
$Q_{\text{tot}}$ (kWh)	2.9	3.0

\*Test # B 4,5,6,7 averaged values

\*\* Test # B 7

Table 9. Comparison of Energy Savings and Drying Times

Mode	Test Parameters	$\bar{Q}$ spec (kWh/kg H <sub>2</sub> O)	Energy Savings (%)	$\bar{t}$ cycle (min)
Baseline 1 B 4,5,6,7,13	$P_{\text{heater}} = 4.55 \text{ kW}$ $P_{\text{fan}} = 0.25 \text{ kW}$ $\dot{V} = 118 \text{ cfm}$ $T_{\infty} = 20^{\circ}\text{C}$	1.444	-	40
Baseline 2 B 11, 12	as above except $T_{\infty} = 10^{\circ}\text{C}$	1.628	-12.7	45
Baseline 3 B 19, 20, 21	$P_{\text{heater}} = 3.1-3.45 \text{ kW}$ $P_{\text{fan}} = 0.25 \text{ kW}$ $V = 118 \text{ cfm}$ $T_{\infty} = 20^{\circ}\text{C}$	1.431	0.9	52-60
Reduced Air Flow Rate & Heater Input B 14,15,16,17, 18	$P_{\text{heater}} = 3.08-3.43 \text{ kW}$ $P_{\text{fan}} = 0.25 \text{ kW}$ $V = 62 -85 \text{ cfm}$ $T_{\infty} = 20^{\circ}\text{C}$	1.324	8.3	51 - 59
Recirculation RC 2,3,4,6,7	$P_{\text{heater}} = 4.5 \text{ kW}$ $P_{\text{fan}} = 0.25 \text{ kW}$ $\dot{V} = 116 \text{ cfm}$ $R = 49 - 72\%$ $T_{\infty} = 20^{\circ}\text{C}$	1.227 (1.294 -1.177)	15.0 (10.4 -18.5)	43 43
HX - Preheat PH 1,2,3,5	$P_{\text{heater}} = 4.5 \text{ kW}$ $P_{\text{fans}} = 0.35 \text{ kW}$ $\dot{V} = 117 \text{ cfm}$ $T_{\text{inlet}} = 7 - 11^{\circ}\text{C}$	1.197	26.5*	39
HX - Recirculation 1 HX 1,2,3,8	$P_{\text{heater}} = 4.55 \text{ kW}$ $P_{\text{fans}} = 0.35 \text{ kW}$ $V = 120 \text{ cfm}$ $T_{\infty} = 20^{\circ}\text{C}$	1.537	-6.4**	60.5
HX - Recirculation 2 HX 4,5,6	$P_{\text{heater}} = 3.15 - 3.5 \text{ kW}$ $P_{\text{fans}} = 0.35 \text{ kW}$ $V = 120 \text{ cfm}$ $T_{\infty} = 20^{\circ}\text{C}$	1.464	-1.4**	63
Dehumidifier D5	$P_{\text{compr}} = 0.837 \text{ kW}$ $P_{\text{fans}} = 0.3 \text{ kW}$ $\dot{V} = 180 \text{ cfm}$ $T_{\infty} = 20^{\circ}\text{C}$	0.970	32.8**	150
Dehumidifier /HX DH 1,2,3	$P_{\text{compr}} = 0.655 - 0.745 \text{ kW}$ $P_{\text{fans}} = 0.4 \text{ kW}$ $\dot{V}_{\text{RC}} = 130 \text{ cfm}$ $V_{\text{open}} = 36 - 113 \text{ cfm}$ $T_{\infty} = 20^{\circ}\text{C}$	1.024 - 1.215	15.9-29.1**	120 -145

\* Compared to Baseline 2. Energy savings are estimated to be in the order of 20% for  $T_{\infty} = 20^{\circ}\text{C}$  in both cases.

\*\* All energy consumed by the dryer can be added to the indoor air to reduce winter heating loads.

Table 10. Summary of Technical Improvements and Energy Saving Measures

Design Options

(List does not indicate priority of savings or cost effectiveness)

1. Improve Lint Filters\*
2. Improve Seals at Drum and Door
3. Add Insulation
4. Air Flow Design Changes
5. Reversible Drum Rotation
6. Use High Efficiency Motors
7. Improve High Limit Thermostats\*
8. Improve Automatic Termination Systems
9. Vent Dryer Exhaust Air into House in Winter
10. Reduce Air Flow Rate and Heater Input\*
11. Recirculate Exhaust Air\*
12. Preheat Inlet Air with an Air-to-Air Heat Exchanger\*
13. Recirculate and Condense with an Air-to-Air Heat Exchanger\*
14. Recirculate and Condense with a Water-to-Air Exchanger
15. Recirculate and Condense with a Heat Pump\*
16. Vacuum Drying

---

\* Investigated in this paper

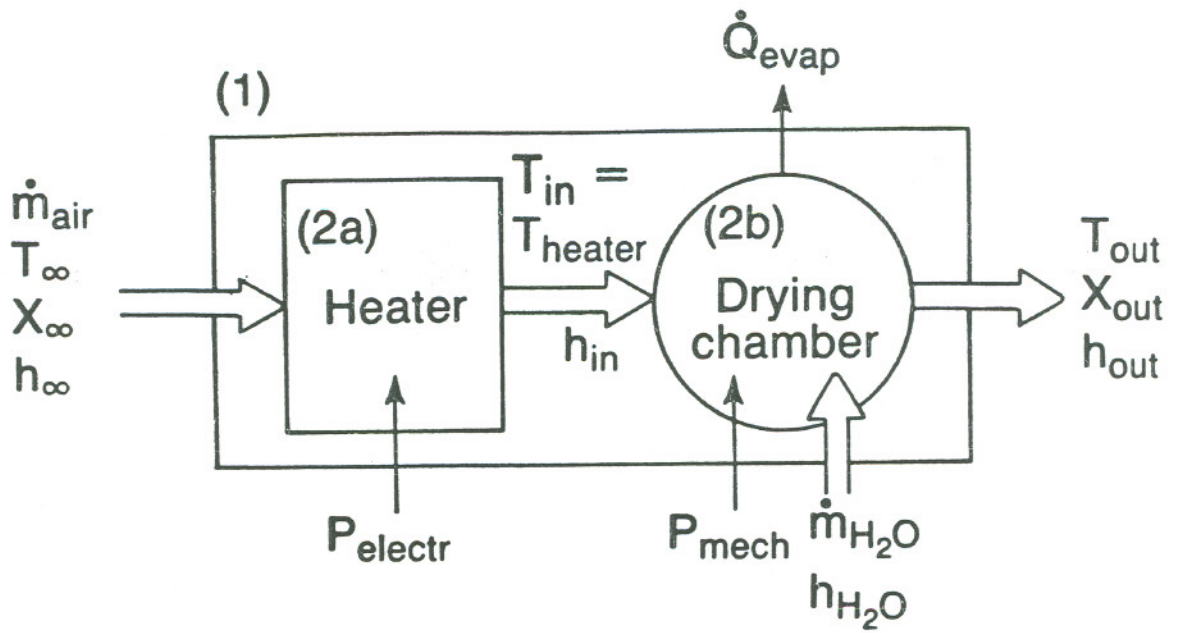

XBL 837-2791

Figure 1. Schematic diagram of clothes dryer.

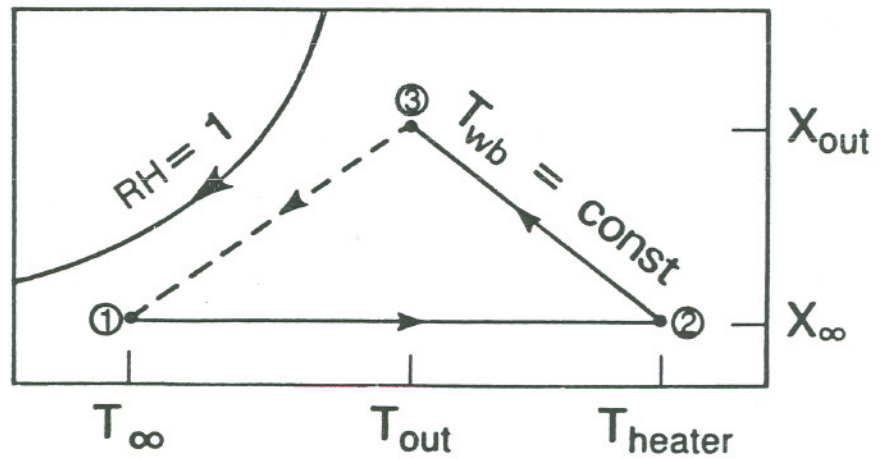

XBL 837-2792

Figure 2. Psychrometric chart including drying and heat recovery process.

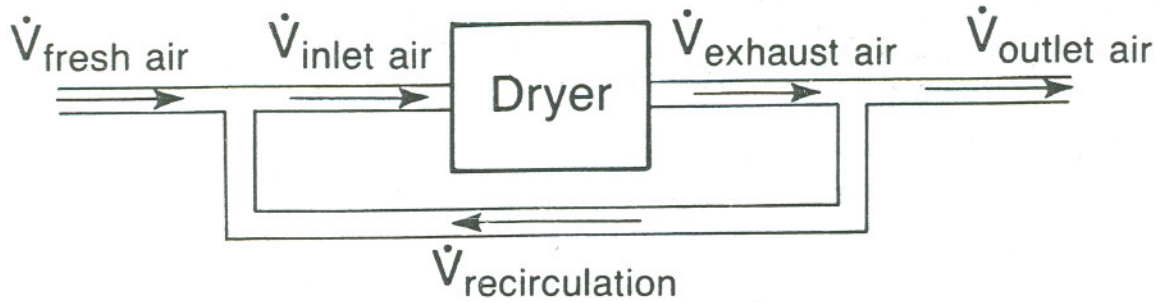

XBL 837-2785

Figure 3. Schematic diagram of dryer with recirculation.

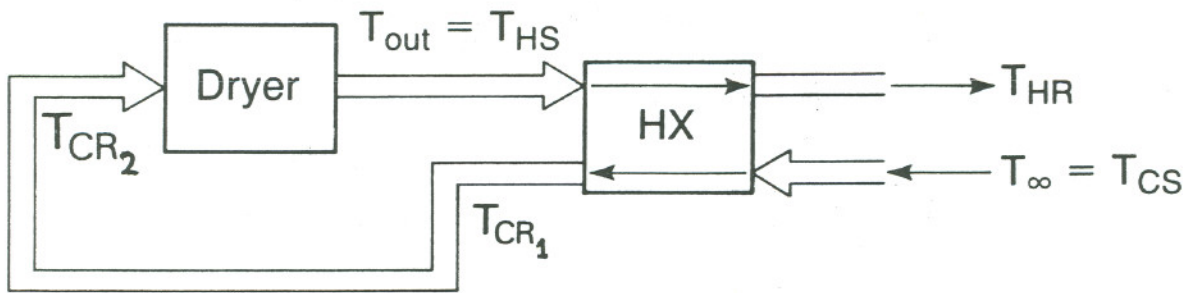

XBL 837-2784

Figure 4. Schematic diagram of dryer with heat recovery, preheating mode.

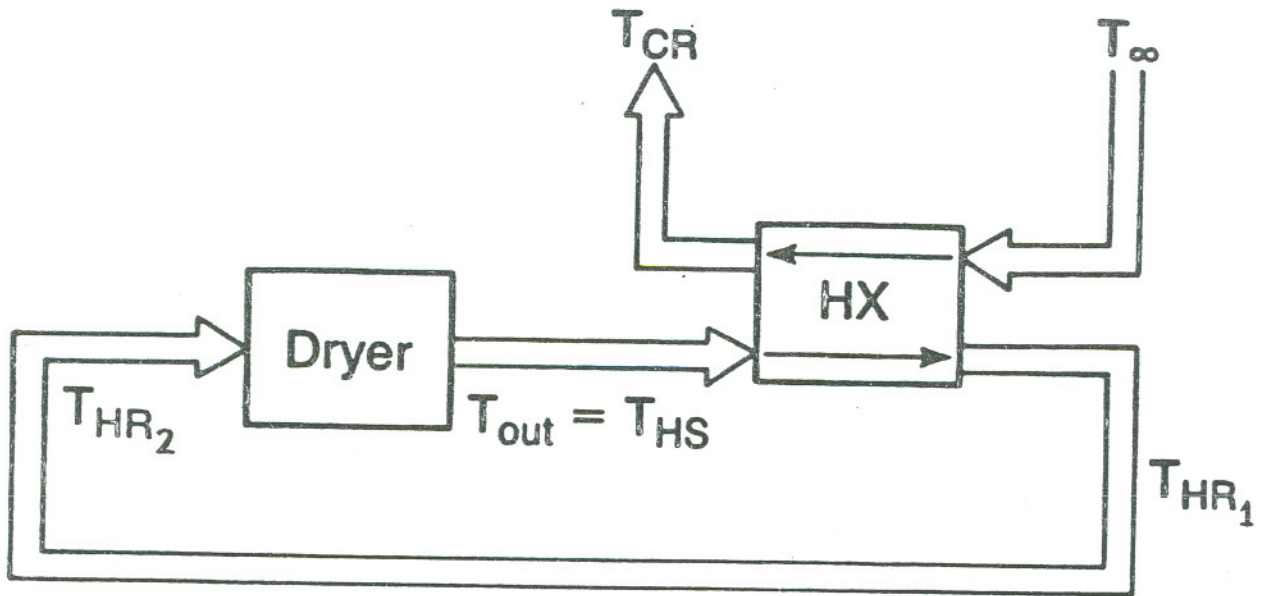

XBL 837-2782

Figure 5. Schematic diagram of dryer with heat recovery, recirculation/condensation mode.

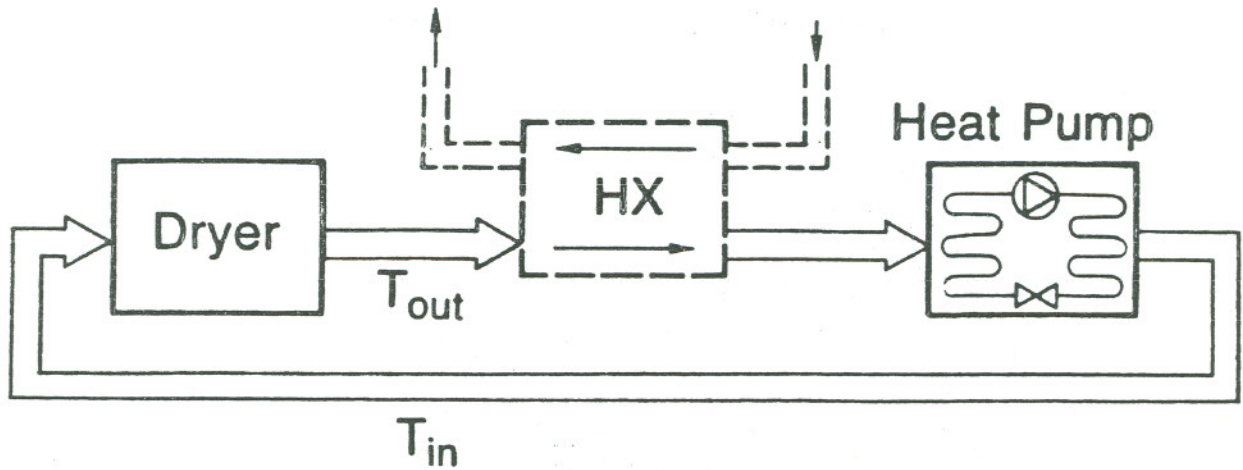

XBL 837-2786

Figure 6. Schematic diagram of dryer with a heat pump.

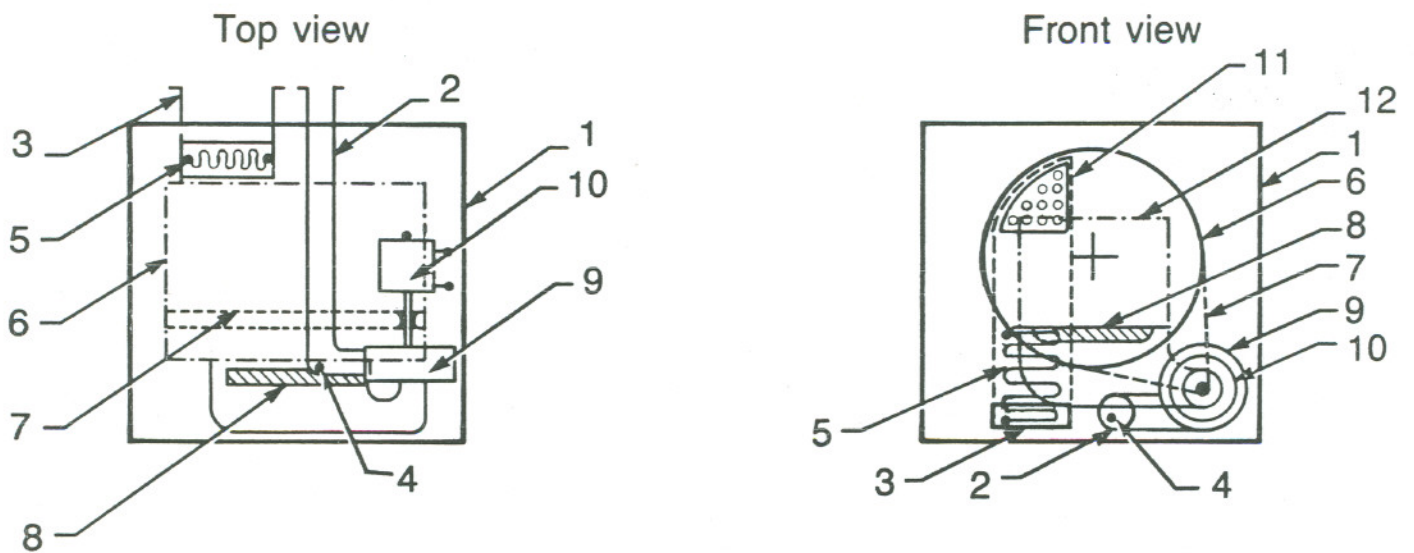

### Identification of components:

1. Clothes dryer housing
2. Exhaust air duct
3. Inlet air duct
4. High-limit thermostat
5. Heating element
6. Drying chamber (rotating drum)
7. Drive belt
8. Exhaust air outlet of drying chamber and lint filter
9. Blower on exhaust air side
10. Motor for drum drive and blower
11. Hot air inlet of drying chamber
12. Front door

XBL 837-2787

Figure 7. Top and Front View of Clothes Dryer

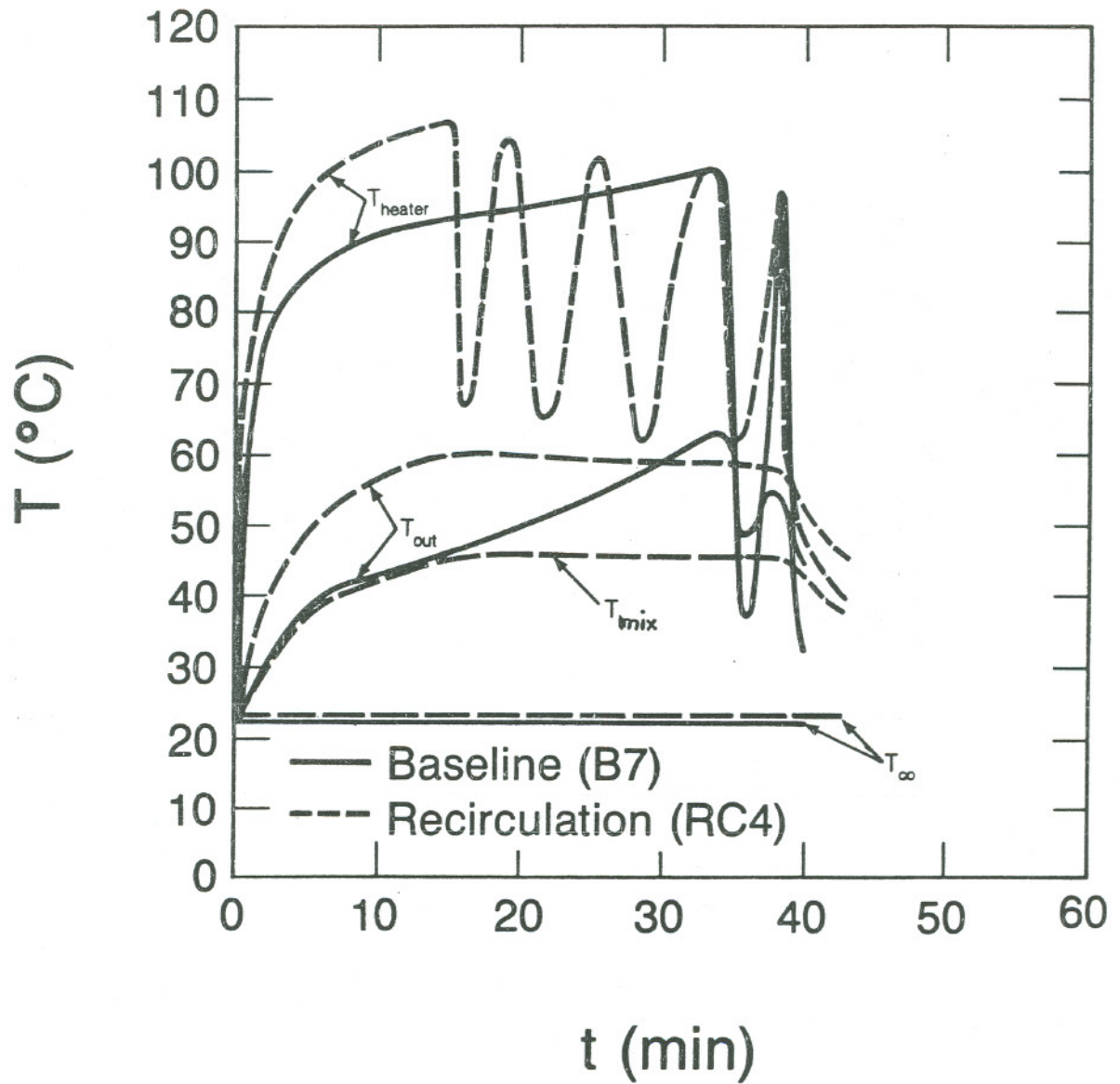

XBL 837-2781

Figure 8. Transient operating temperatures for baseline and recirculation tests.

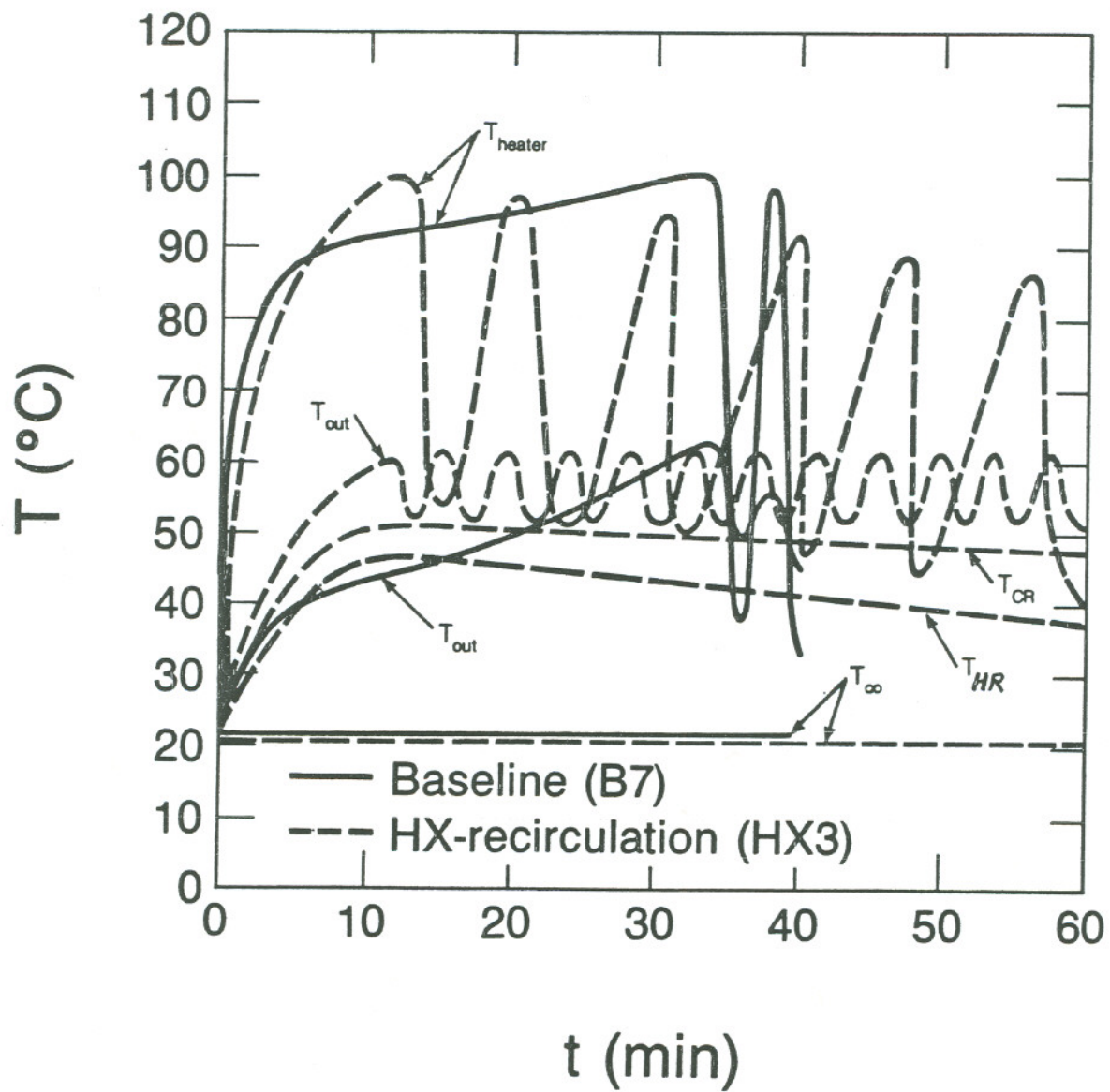

XBL 837-2780

Figure 9. Transient operating temperatures for baseline and heat exchanger-recirculation tests.

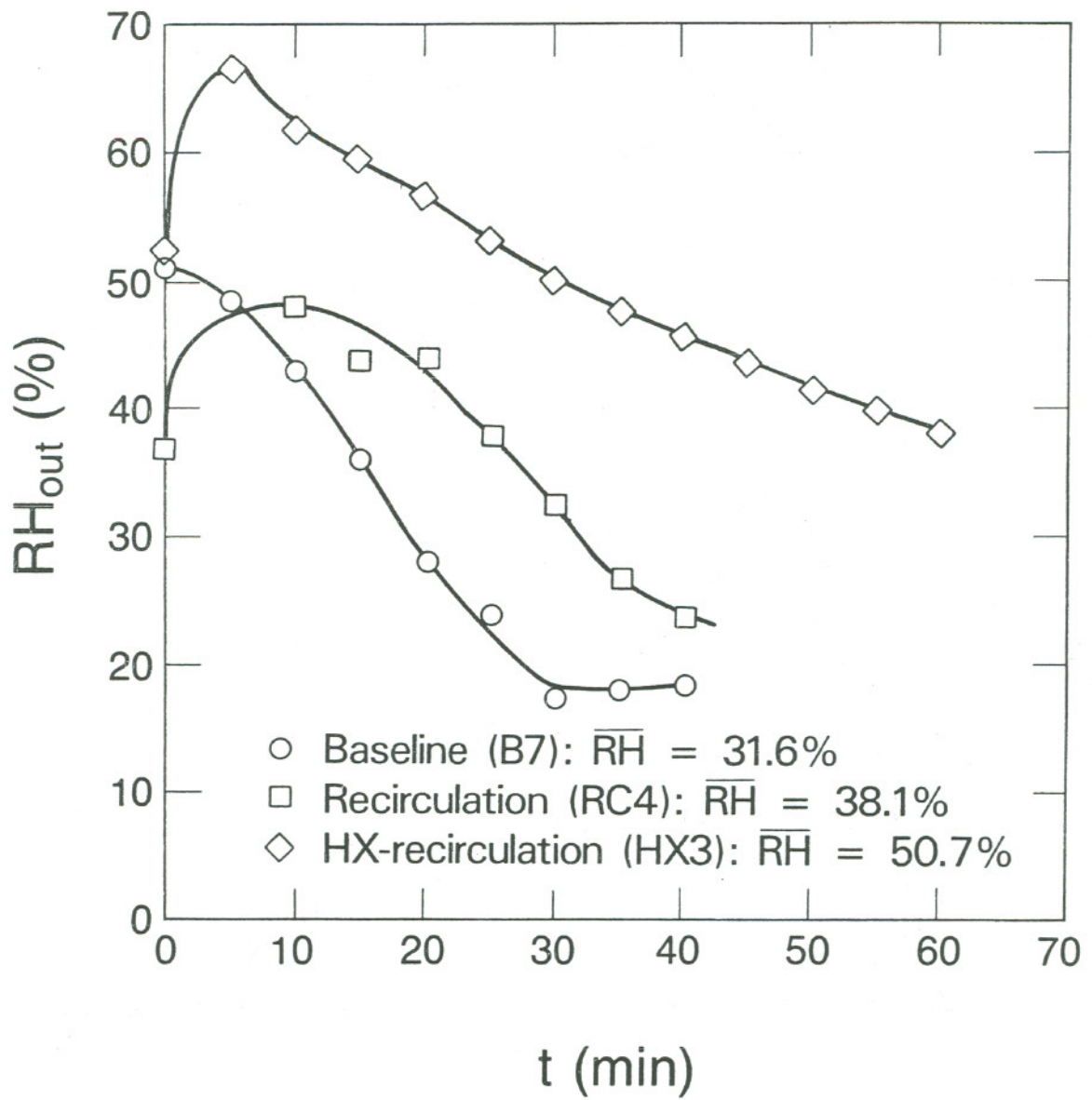

XBL 837-2793

Figure 10. Transient relative humidities of exhaust airstream.

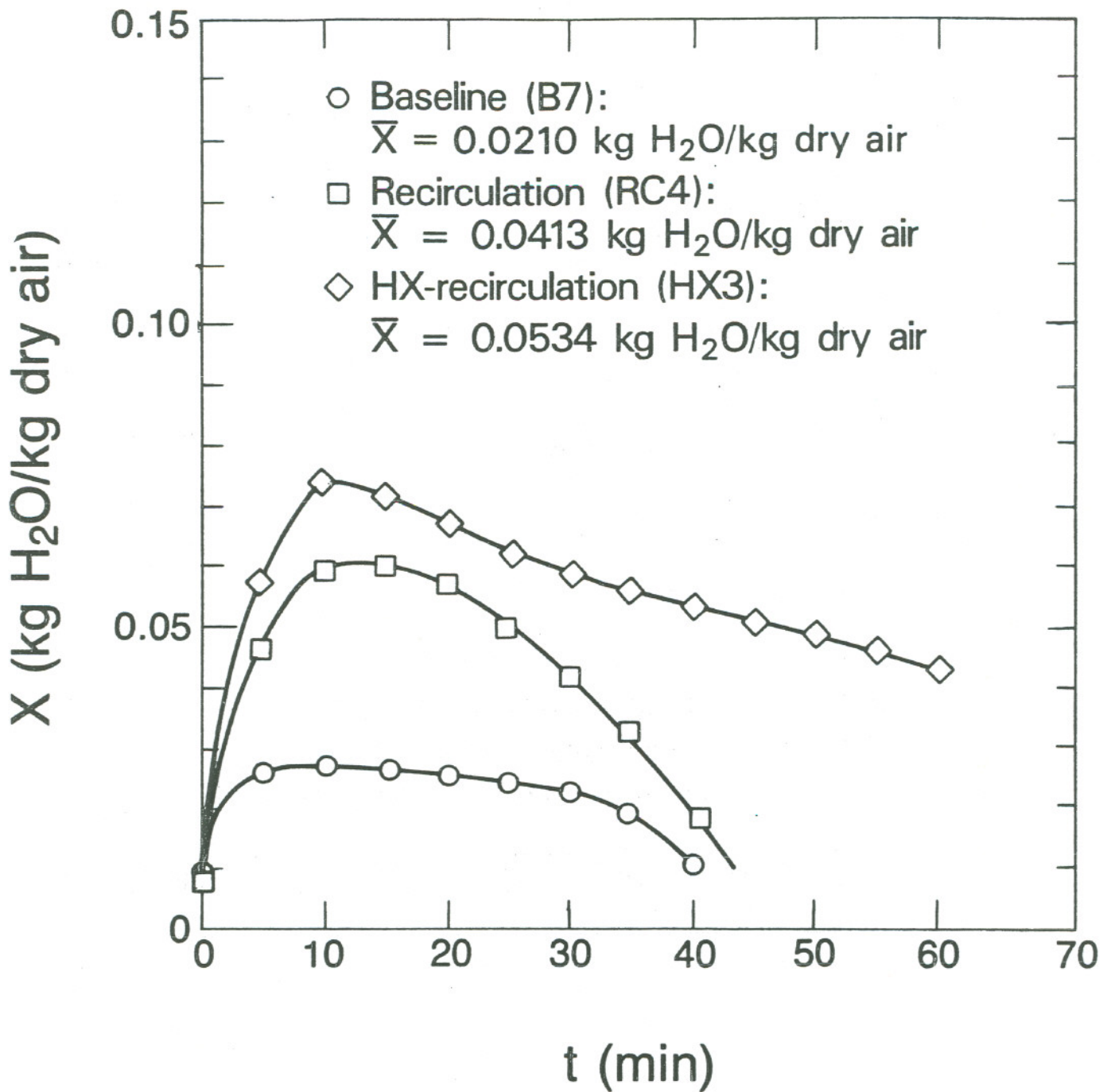

XBL 837-2777

Figure 11. Transient absolute humidities of exhaust airstream.

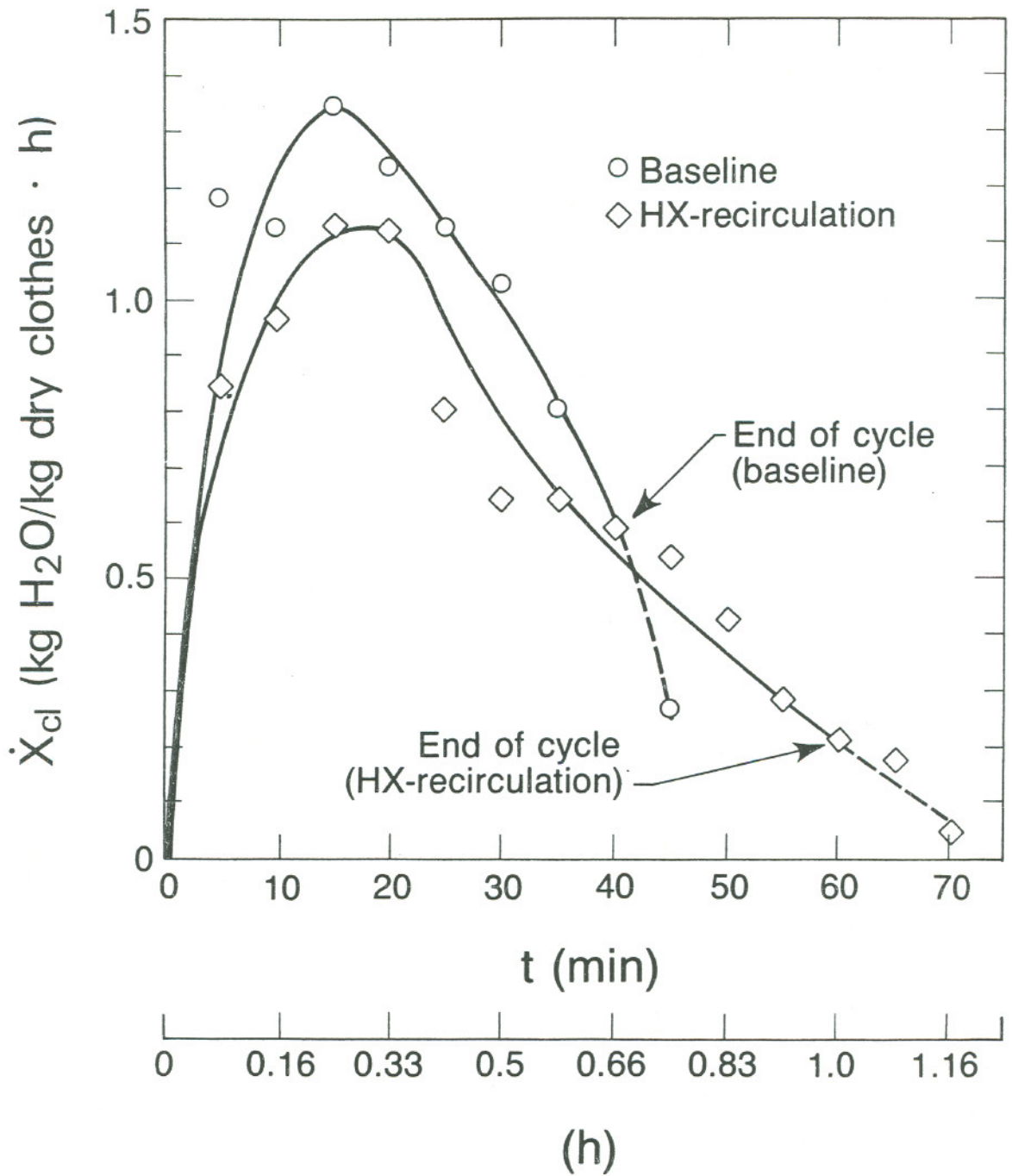

XBL 837-2779

Figure 12. Drying kinetics for baseline and heat exchanger-recirculation tests.

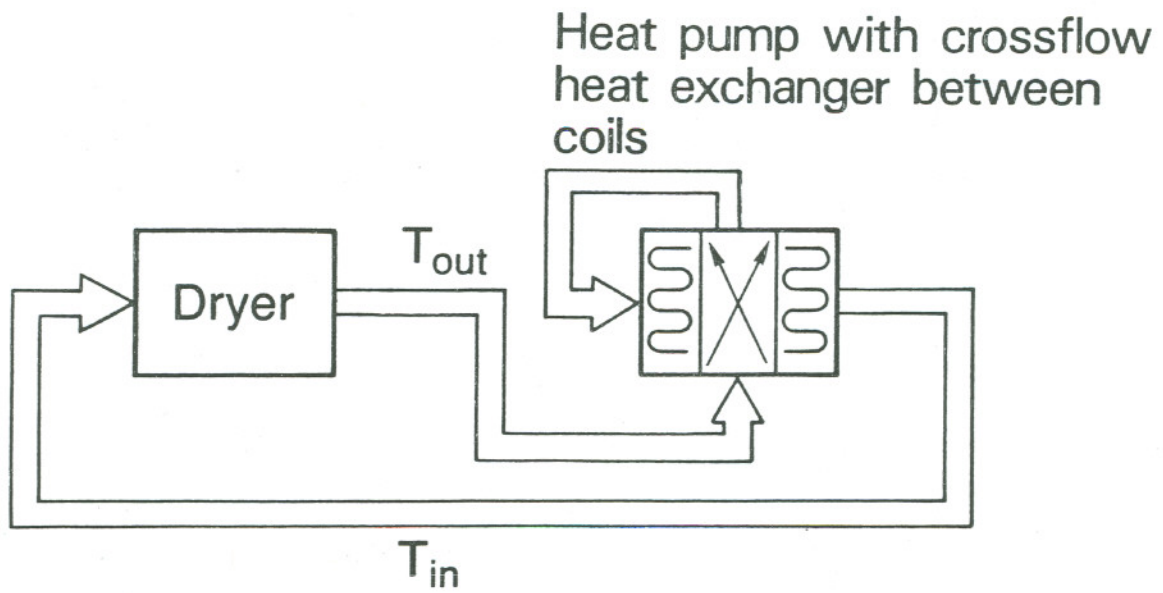

XBL 837-2783

Figure 13. Schematic diagram of clothes dryer with a heat pump and an air-to-air heat exchanger.



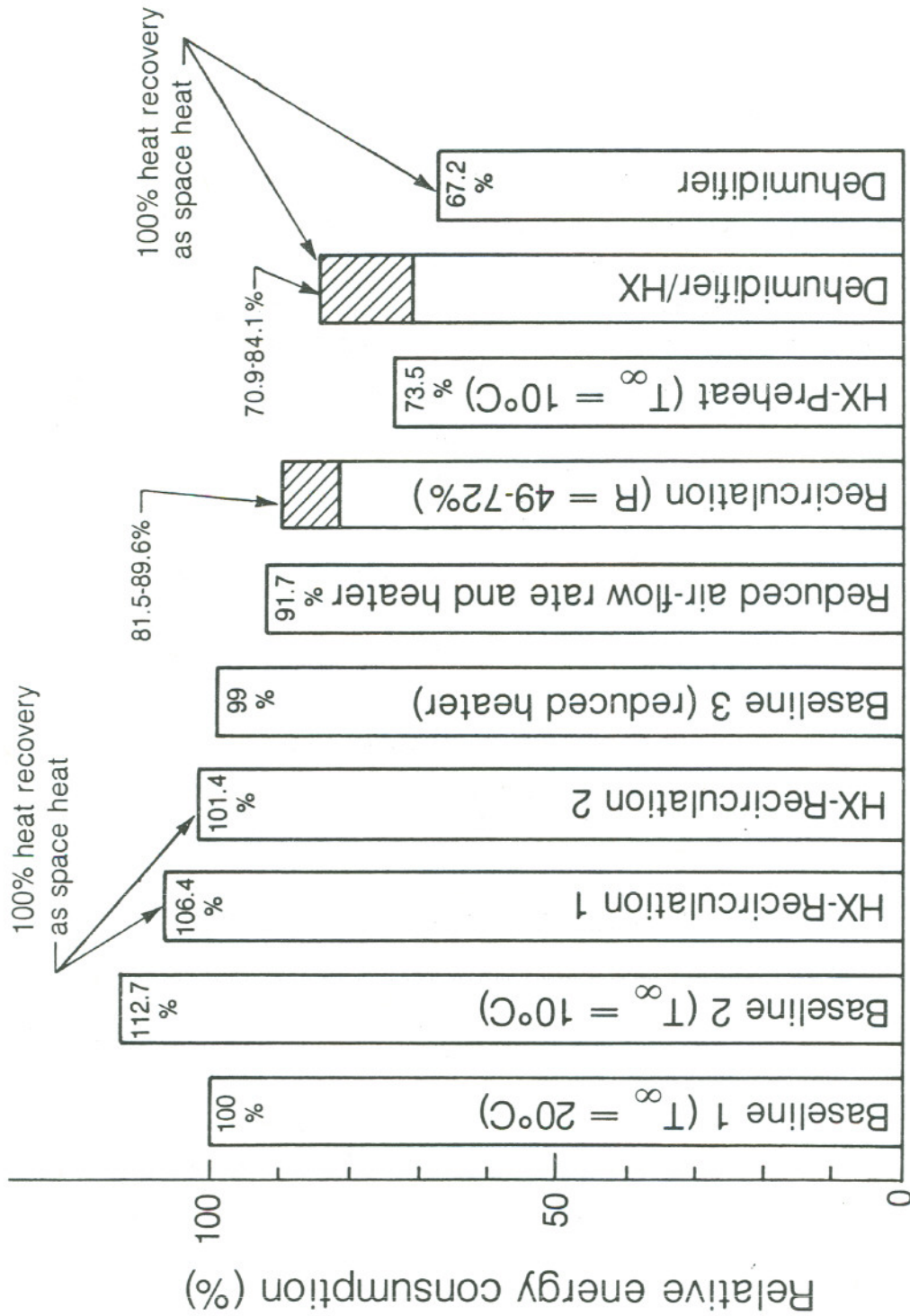

XBL 838-840

Figure 15. Comparison of energy savings.

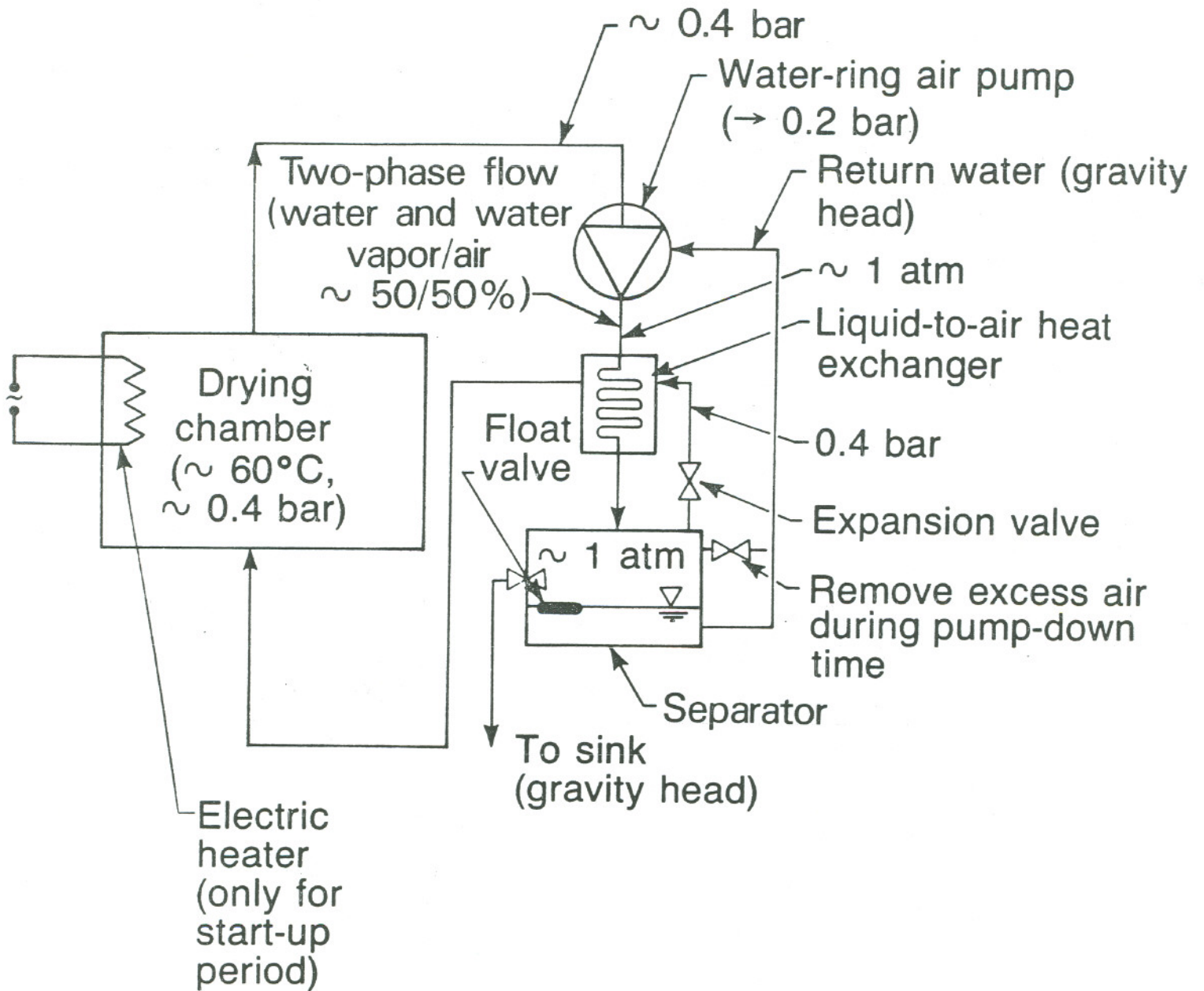

XBL 837-2790

Figure 16. Schematic diagram of vacuum clothes drying.

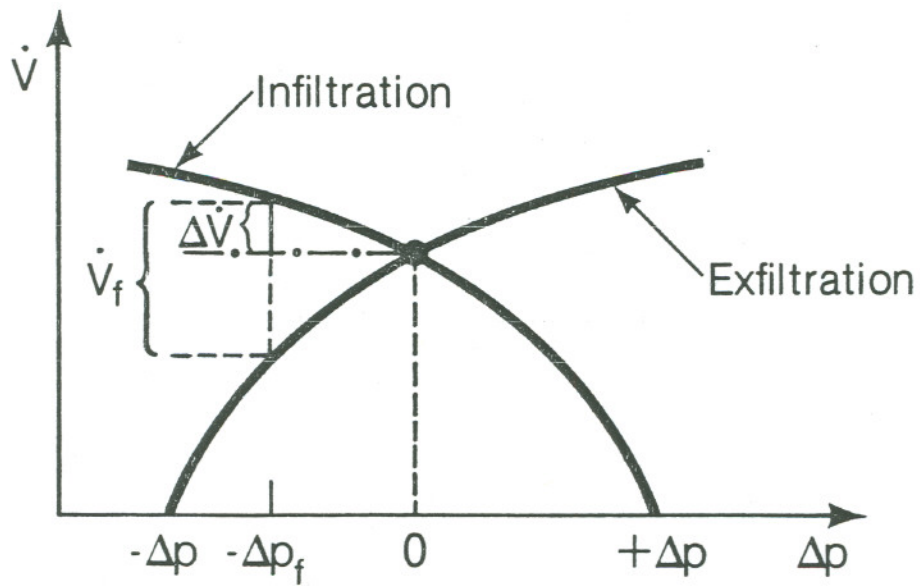
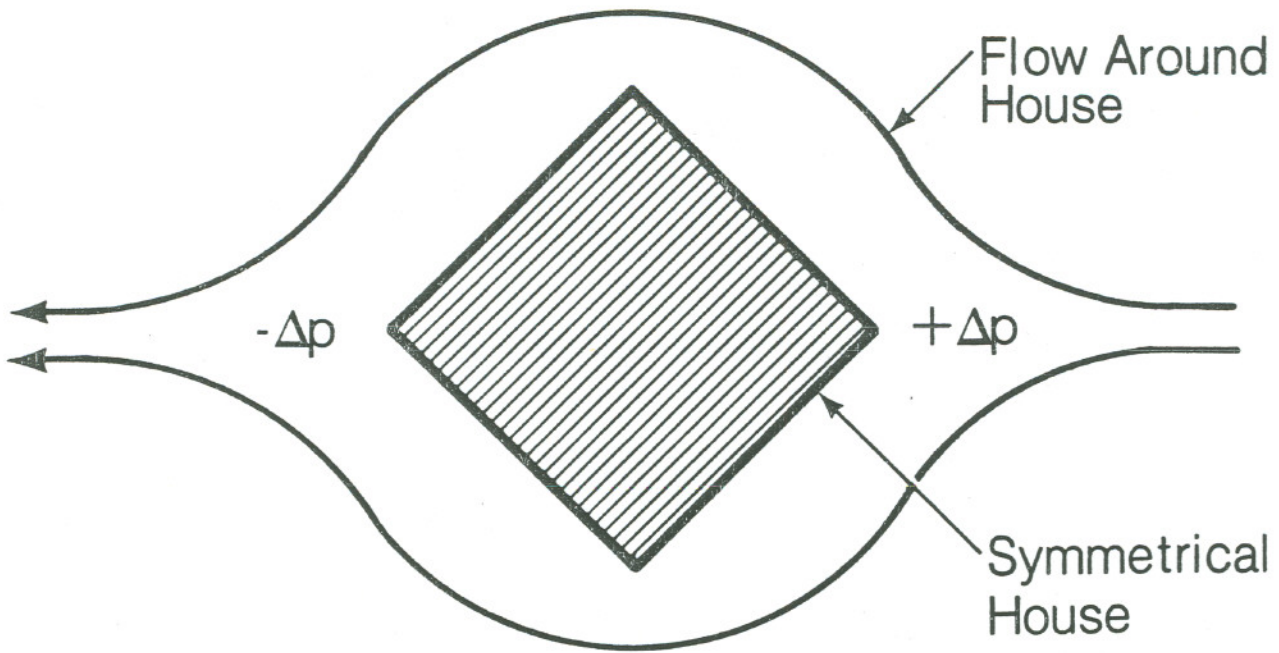

XBL 837-455

Figure 17. Infiltration and exfiltration versus pressure difference in a house.