

To be presented at the Western States
Section/The Combustion Institute
Paper No. 77-40, Fall Meeting,
October 17-18, 1977, Palo Alto, CA

CNF-771015--9

Energy and Environment Division



Fuel Nitrogen Conversion And Catalytic
Combustion

Ronald D. Matthews
Robert F. Sawyer

Department of Mechanical Engineering
University of California, Berkeley

October 1977

Berkeley Laboratory University of California/Berkeley

Prepared for the U.S. Department of Energy under Contract No. W-7405-ENG-48

MASTER

LBL-6396

DISCLAIMER

This report was prepared as an account of work sponsored by an agency of the United States Government. Neither the United States Government nor any agency thereof, nor any of their employees, makes any warranty, express or implied, or assumes any legal liability or responsibility for the accuracy, completeness, or usefulness of any information, apparatus, product, or process disclosed, or represents that its use would not infringe privately owned rights. Reference herein to any specific commercial product, process, or service by trade name, trademark, manufacturer, or otherwise does not necessarily constitute or imply its endorsement, recommendation, or favoring by the United States Government or any agency thereof. The views and opinions of authors expressed herein do not necessarily state or reflect those of the United States Government or any agency thereof.

DISCLAIMER

Portions of this document may be illegible in electronic image products. Images are produced from the best available original document.

— LEGAL NOTICE —

This report was prepared as an account of work sponsored by the United States Government. Neither the United States nor the Department of Energy, nor any of their employees, nor any of their contractors, subcontractors, or their employees, makes any warranty, express or implied, or assumes any legal liability or responsibility for the accuracy, completeness or usefulness of any information, apparatus, product or process disclosed, or represents that its use would not infringe privately owned rights.

NOTICE

This report was prepared as an account of work sponsored by the United States Government. Neither the United States nor the United States Energy Research and Development Administration, nor any of their employees, nor any of their contractors, subcontractors, or their employees, makes any warranty, express or implied, or assumes any legal liability or responsibility for the accuracy, completeness or usefulness of any information, apparatus, product or process disclosed, or represents that its use would not infringe privately owned rights.

FUEL NITROGEN CONVERSION AND CATALYTIC COMBUSTION

Ronald D. Matthews*
Robert F. Sawyer

Department of Mechanical Engineering
University of California
Berkeley, California 94720

ABSTRACT

Catalytic combustion for equivalence ratios between 0.7 and 1.6 was investigated. The combustor consisted of a 5 cm diameter monolithic Cordierite substrate with a γ -alumina washcoat and platinum coating. Reactants were propane/oxygen/argon mixtures. Trace amounts of either nitric oxide or ammonia were added for the fuel-nitrogen portion of the study. Conversion of these two model fuel-nitrogen compounds to nitric oxide was measured as a function of equivalence ratio, adiabatic flame temperature, and fuel nitrogen concentration. The trends were compared to those typical of homogeneous combustion. Use of oxygen/argon mixtures as the oxidizer allowed decoupling of the flame temperature and equivalence ratio and made possible investigation of catalytic combustion under stoichiometric conditions which would not be possible with a fuel/air mixture because of material limitations. Catalyst temperatures, combustion efficiency, and emissions of CO, CO₂, and UHC's were investigated.

* Present address, University of Illinois, Department of Mechanical Engineering, Urbana, Illinois.

MASTER

DISTRIBUTION OF THIS DOCUMENT IS UNLIMITED *eb*

INTRODUCTION

Restrictions imposed by the energy situation are forcing commercial energy consumers to switch from natural gas to other fuels such as residual fuel oil, coal, and synthetic fuels made from coal or shale. This is a source of concern from an air pollution perspective. Because these fuels may contain relatively high concentrations of nitrogen and sulfur, their use can lead to increased emissions of oxides of nitrogen (NO_x) and sulfur oxides (SO_x). The principal use of these fuels has been, and will continue to be, in stationary sources such as electric utilities.

As shown in Table 1 (Gaynor, 1976), in July 1976 coal was the primary energy source for 44.2% of the energy consumed by electric utilities. Petroleum contributed 14.6% and natural gas was 16.9%. The amount of natural gas consumed by the electric utilities may be expected to decrease sharply. The consumption of coal and petroleum and, to a lesser extent, hydroelectric and nuclear energy will increase proportionately. Similarly, 46.2% of industrial process heat is derived from the consumption of natural gas, and this should be expected to decrease in the near future.

There are two sources for NO_x emissions from combustion systems. Until recently, the most significant source has been the thermal fixation of atmospheric nitrogen (N_2) via the Zeldovich mechanism. However, it has been estimated that current use of fuels containing bound nitrogen may be responsible for as much as half the NO_x emissions from stationary sources (Sarofim and Flagan, 1976). As pointed out by Appleton and Heywood (1973), fuel nitrogen reacts much more readily

TABLE I
Primary Energy Consumption by Sector and Source - July 1976*

	COAL	PETROLEUM**	NATURAL GAS	HYDROELECTRIC AND NUCLEAR	PRIMARY ENERGY CONSUMPTION (10 ¹⁵ Btu)
Residential and Commercial	1.6%	61.8%	36.6%	—	.812
Industrial	22.7%	30.9%	46.2%	.2%	1.482
Transportation	<0.1%	97.7%	2.1%	Negligible	1.624
Electric Utilities	44.2%	14.6%	16.9%	23.8%	1.971
Percent of Total Energy Consumption	20.7%	48.1%	23.1%	8.0%	5.89

* From data tabulated by the Federal Energy Administration (Gaynor, 1976)--Rows may not add to 100% because of round-off errors.

** Includes gasoline, jet fuel, residual fuel oil, distillate fuel oil, and other minor petroleum products. Residual fuel oil accounted for 17.5% of the refined petroleum products which were consumed in July 1976.

to form nitric oxide (NO) than does atmospheric nitrogen.

Power plants are constrained by system thermal efficiency considerations to operate near stoichiometric* to minimize stack losses. Fortunately, two combustion techniques have shown the potential of suppressing air pollutant emission even under combustion conditions near stoichiometric: catalytic combustion and staged combustion. Typical catalytic combustors consist of ceramic monoliths with small diameter passages. The ceramic is lightly coated with a catalyst, such as platinum or palladium. Staged combustion is a method of combining fuel rich combustion with fuel lean combustion to stabilize either an overall fuel lean or overall stoichiometric process. NO_x production is inhibited in the fuel rich stage because of the lack of available oxygen. The low temperature and excess oxygen in the second stage inhibit NO_x formation from thermal fixation and promote the oxidation of CO and UHC's. It has been suggested that the optimum system for power plants might eventually be shown to be a combination of these two, staged catalytic combustion. This would involve catalytic combustion under fuel rich conditions followed by energy extraction, air addition, and fuel lean catalytic combustion for exhaust purification and further energy extraction. Therefore, catalytic combustion under lean, stoichiometric, and rich operating conditions is an area of reasearch which might aid in the production of clean energy from fossil fuels.

Two investigations have studied catalysis and staged combustion devices. Siminski and Shaw (1977) used a catalyst as the second stage

* The fuel/air mixture which has neither excess air nor excess fuel is stoichiometric.

of a two stage combustor. However, the overall equivalence ratio* was between 0.1 and 0.3 and the extent of oxidation in the catalyst was small. This indicates that the catalyst had an exhaust purification function rather than a significant role in the combustion process. In the other study (Yamagishi, et al., 1974), nickel catalysts were positioned at the exit from the fuel rich primary stage of a two stage combustor. The effect of catalyst type on emissions of nitrogenous species from the first stage was investigated. Whether the catalytic bed primarily acted as an exhaust purification catalyst or supported the combustion process is unclear.

There appear to have been no published reports specifically concerning catalytic combustion of near-stoichiometric mixtures. The purpose of this investigation was to characterize catalytic combustion of mixtures ranging from lean ($\phi = 0.7$) to rich ($\phi = 1.6$) and including stoichiometric. Catalyst temperature and emissions of CO, CO₂, UHC's, and fuel-derived NO were measured as functions of important combustion parameters.

EXPERIMENTAL OBJECTIVES

Previous investigations of catalytic combustion have been aimed primarily at developing catalytic combustors for very fuel lean operation. There is very little published information about fuel rich and near stoichiometric catalytic combustion. Furthermore, there have been no major studies of the fate of fuel nitrogen in catalytic combustion systems. This work characterizes emission of CO, CO₂, UHC's, and

* The equivalence ratio is the actual fuel/air ratio divided by the stoichiometric fuel/air ratio.

fuel-derived NO in a catalytic combustor. Comparison with emissions from a flat flame burner operating under the same conditions is made to allow an estimation of the extent to which heterogeneous reactions dominate the fuel nitrogen conversion mechanism.

Figure 1 shows the effect of the oxygen to argon ratio on the adiabatic flame temperature as a function of C_3H_8/O_2 equivalence ratio. By varying the O_2/Ar ratio while maintaining a constant C_3H_8/O_2 ratio, it is possible to change the flame temperature at constant equivalence ratio. This process is illustrated in Figure 1 by line A-B. By varying both ratios simultaneously, it is possible to change the equivalence ratio while maintaining the flame temperature constant, as illustrated by line B-C. Use of the O_2 -Ar mixture as an oxidizer, then allows a decoupling of two normally interdependent combustion parameters, equivalence ratio and adiabatic flame temperature. Monitoring the catalyst bed temperature as a function of equivalence ratio may then indicate the effect of reactant composition (oxidizing, stoichiometric, reducing) on bed temperatures. Furthermore, emissions of CO , CO_2 , UHC's, and fuel-NO may then be studied as a function of equivalence ratio at a constant adiabatic flame temperature. Propane was chosen as a fuel because its combustion characteristics resemble those of commercial fuels and it has been the fuel most often used in previous catalytic combustion experiments.

Previous investigations of (very fuel lean) catalytic combustion have found that the combustion efficiency increases with increasing equivalence ratio, increasing inlet temperature, and decreasing inlet velocity. The combustion efficiency for near stoichiometric and fuel rich catalytic combustion has not been reported. In this investigation,

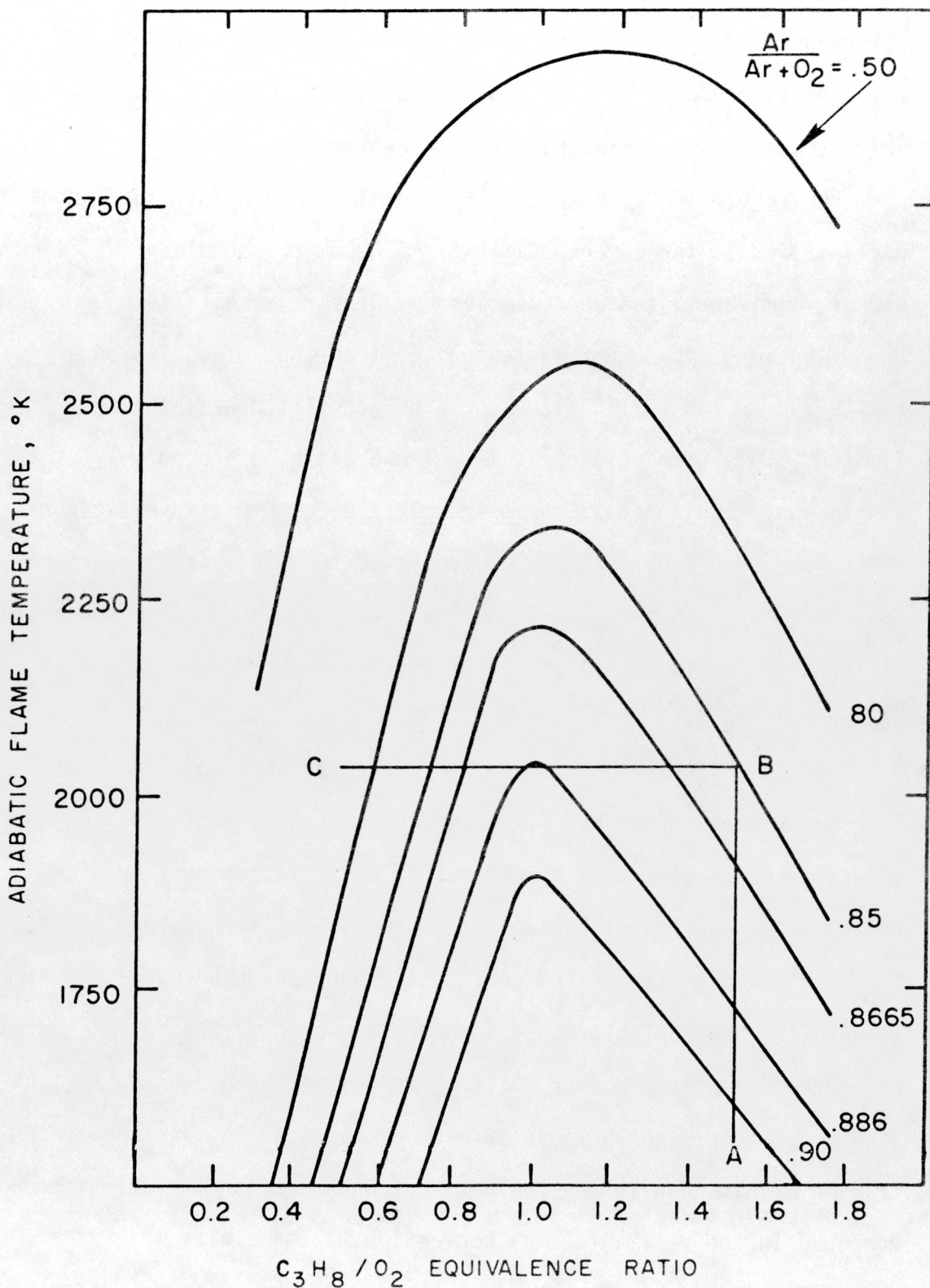

Figure 1. Effect of the Argon to Oxygen Ratio on the Relationship Between Equivalence Ratio and Adiabatic Flame Temperature

the inlet temperature was constrained to be 298 K. The inlet velocity was about 0.05 m/sec, a value chosen to match the optimum flat flame burner operating conditions. This low inlet temperature might be expected to cause inefficient catalytic combustion, but the very low inlet velocity should increase the combustion efficiency.

For comparison purposes, both a catalytic and flat flame burner were studied at the same conditions. A ceramic, uncooled flat flame burner, similar to the one described by Sawyer, et al. (1976), was used. Because the burner was uncooled, the range of equivalence ratios over which a flat flame could be stabilized was extremely limited. This combustion system was, therefore, operated only at a single equivalence ratio, approximately 1.25. Other investigators have noted that fuel nitrogen is converted to NO at yields approaching 100% for most lean and stoichiometric flames and at yields approaching 0% for very fuel rich flames. All experiments were conducted at a pressure of 10^5 Pa.

Several trends have been noted in parametric studies of fuel nitrogen conversion to NO. Three of the most important of these were investigated to determine the effect of catalytic combustion on NO yields as a function of equivalence ratio, flame temperature and fuel nitrogen concentration. For comparative purposes, the effects of flame temperature and fuel nitrogen concentration on NO yields were studied using the flat flame burner. The term fuel nitrogen "concentration" is somewhat confusing because it may be construed to mean the concentration of nitrogen in the fuel or the concentration of fuel nitrogen compound in the reactants. By convention, it generally means the concentration of nitrogen in the fuel. However, fuel nitrogen "fraction"

may be a less ambiguous term and is used in the remainder of this report in any context where "fuel-N concentration" is not clear. The fuel nitrogen concentration is calculated as the mass flowrate of nitrogen in the reactants divided by the sum of the mass flow rates of the propane and the additive (NH_3 or NO). In this manner, the additive is defined as a fuel. This results in minor differences in operating conditions when using NH_3 and NO because NO is actually an oxidant while NH_3 is a fuel.

EXPERIMENTAL APPARATUS

Figure 2 illustrates the experimental apparatus. For convenience the equipment can be divided into three categories: 1) flow metering and measurement, 2) combustors, housing, probe and sample transfer systems, and 3) analytical equipment. Each of these categories will be discussed in the following subsections.

1) Flow Metering and Measurement

Four reactants flows had to be accurately measured: C_3H_8 , O_2 , Ar and, during the fuel-nitrogen experiments, either NH_3 or NO . Preliminary experiments indicated that there could be substantial difficulties associated with metering and measuring low flowrates of pure NH_3 and NO . For this reason, mixture gases were used which contained approximately 1% NH_3 or NO in an Ar balance. Four Hastings linear mass flowmeters were used to measure the flowrates of C_3H_8 , O_2 , Ar and the mixture gas (NH_3 or NO in an Ar balance). By maintaining the flowrates of C_3H_8 , O_2 and NH_3/Ar constant and varying the Ar flowrate, the adiabatic flame temperature, T_{AD} , can be varied at constant equivalence ratio, ϕ , and fuel nitrogen concentration [FN]. By varying the NH_3

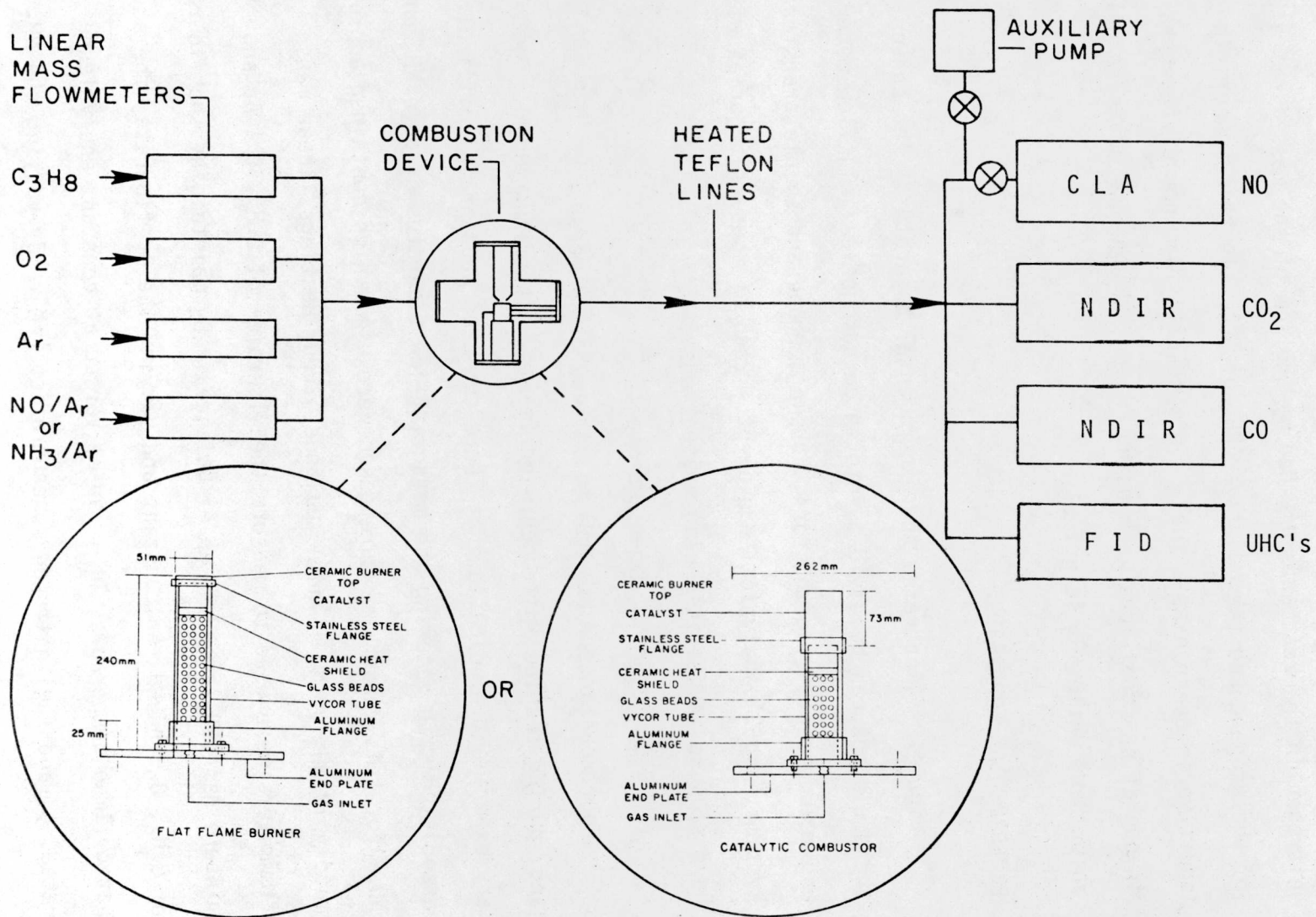

Figure 2. Experimental Apparatus

(or NO)/Ar and Ar flowrates only, the [FN] can be varied at constant ϕ and T_{AD} . All four flowrates must be varied simultaneously to vary ϕ at constant T_{AD} and [FN].

2) Combustion Devices, Housing, and Traversing Mechanism

A six inch glass cross is used to house the flat flame burner and catalytic combustor. Each of the combustors is mounted on an aluminum end plate which can bolt to the bottom flange of the glass cross. A similar end plate, which holds the probe and traversing mechanism, is bolted to the top flange. Plexiglass end plates are bolted to the two side ports and can be removed to ignite the flame with a propane torch.

Figure 3 is a representation of the flat flame burner, which is similar to the one used by Sawyer, et al. (1976). It is an uncooled burner with a 4.6 cm diameter surface which is constructed with Corning Cericor T20-38. The ceramic burner sits atop a Vycor tube which allows visual inspection of the glass beads and ceramic heat shield encased in it. The reactant gas mixture is introduced through the bottom of the end plate. The glass beads serve to flatten the velocity profile.

Figure 3 also shows the catalytic combustor which is very similar to the flat flame burner. It consists of an aluminum end plate, a Vycor housing, glass beads, a ceramic heat shield, and the catalyst. The catalyst consists of a monolithic Cordierite ceramic substrate with a γ -alumina washcoat and a 0.187% platinum loading. This catalyst was made available by ACUREX/Aerotherm. Three thermocouples are imbedded in the catalyst, 18 mm from the centerline and 19, 36.5, and 56 mm from the upstream face. The Vycor tubing allowed visual inspection of the lower face, or upstream face, of the catalyst. Previous investigations have shown that this is where the majority of the

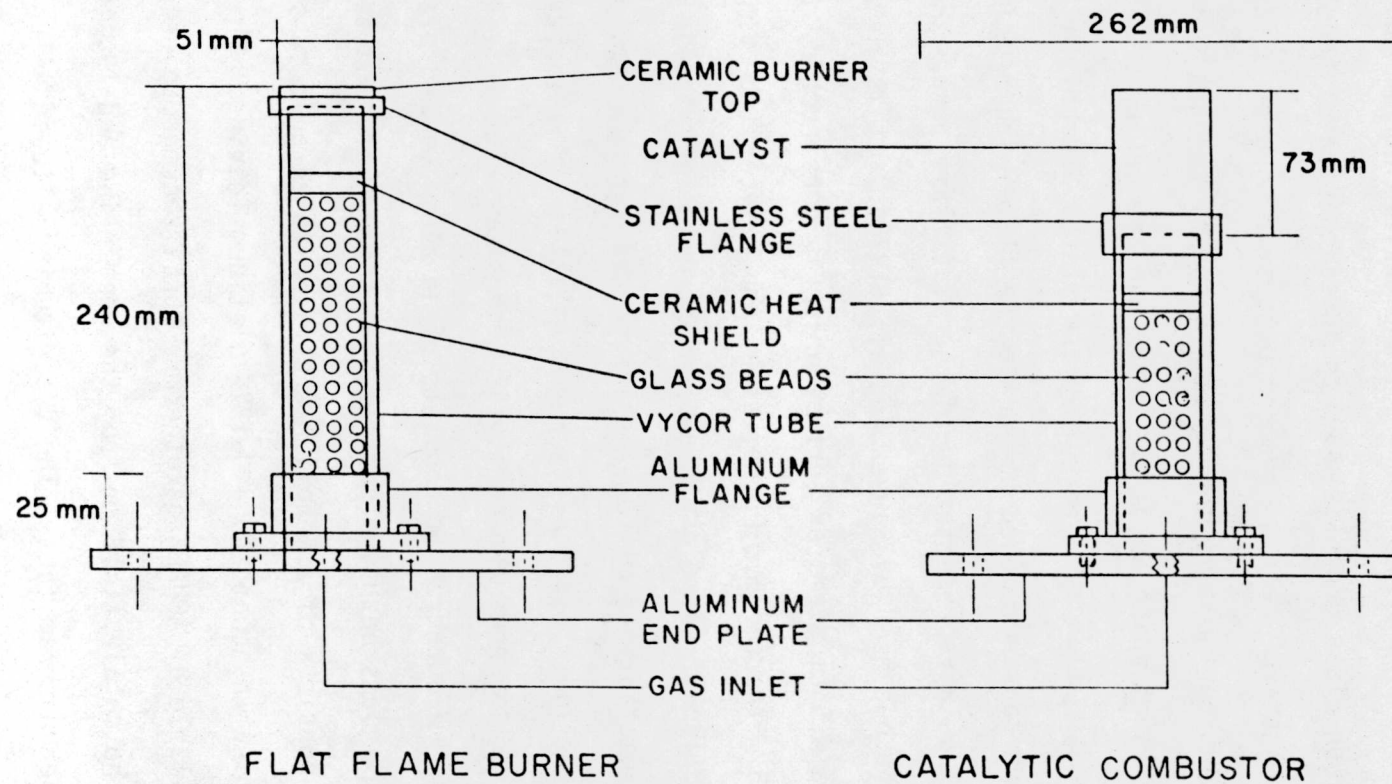

Figure 3. Comparison of the Flat Flame Burner and the Catalytic Combustor

reaction takes place. In general, preheating of the inlet air leads to autoignition of the catalytic combustion process. In the present case, the inlet mixture was not preheated so another form of ignition had to be used. This catalytic combustor is very similar to an uncooled ceramic flat flame burner, and it was ignited in the same manner. With the reactant mixture flowing through the catalyst, a propane torch was held near the combustor exit and a flat flame was established above the downstream face of the catalytic combustor. Heat transfer from the flame to the combustor would gradually raise the surface temperature above the catalytic ignition temperature. The flame would first move into the catalyst section on the centerline, leaving a doughnut shaped flame above the catalyst.

The probe traversing mechanism had manual adjustment in two horizontal degrees of freedom. In the vertical direction, a microscope stage provides coarse adjustment and a motorized micro-positioning device provides fine adjustment. This motorized micropositioner is the Ardel Kinamatic T-100M and allows steps as small as 1μ to be traversed. It is governed by a controller designed and built locally.

A probe of the type used by Schefer (1976) was chosen for this experiment. As shown in Figure 4, it is an aerodynamically quenched quartz microprobe which is housed in a water cooled stainless steel sleeve. Quartz has been shown to be less catalytic than the other commonly used probe material, stainless steel. Cooling is used to inhibit probe reactions. The probe pressure was maintained at less than a half an atmosphere to inhibit probe reactions and eliminate water condensation.

The sample transfer lines were obtained from Technical Heaters, Inc.

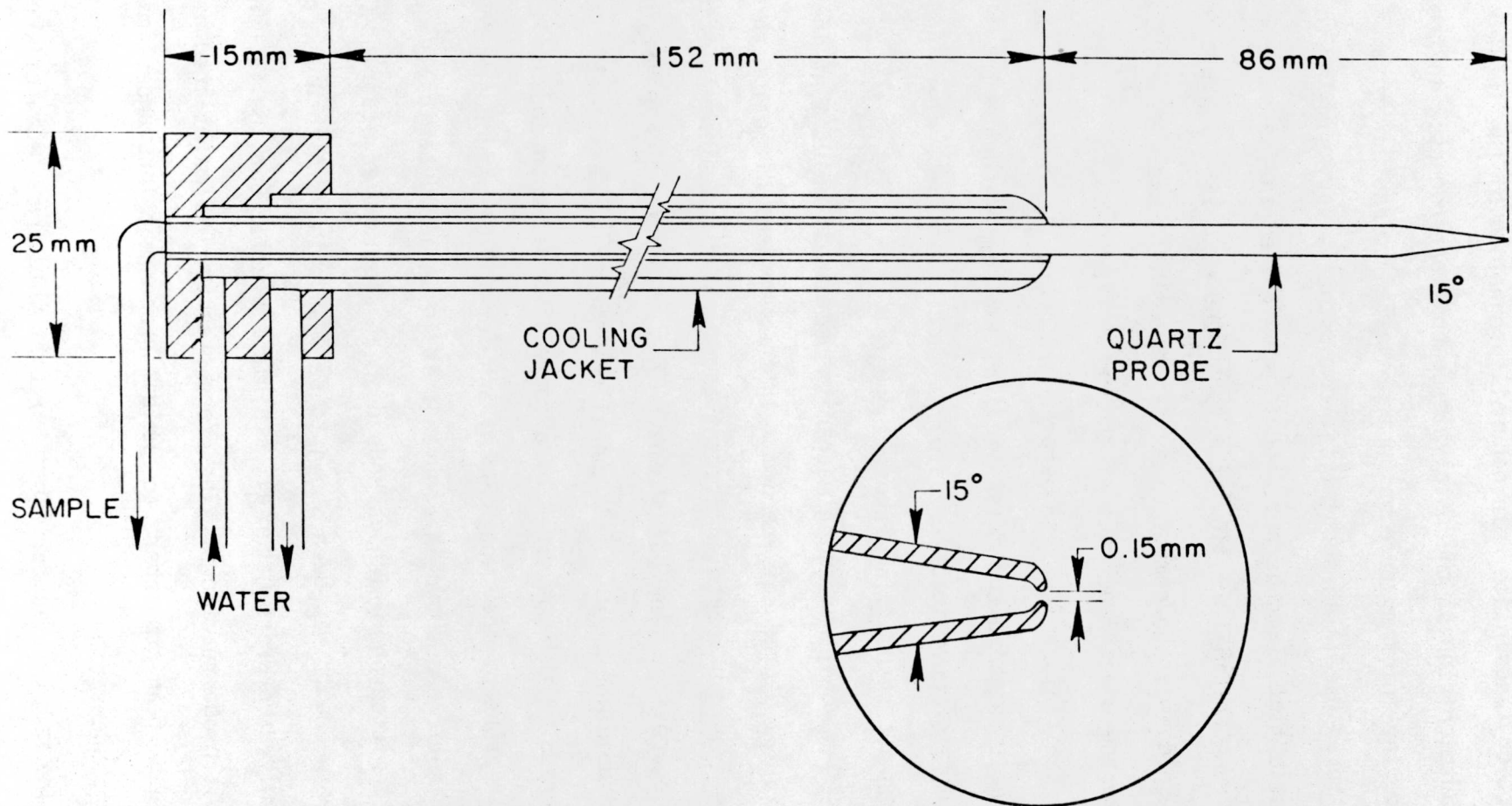

Figure 4. Quartz Gas Sampling Microprobe and Cooling Sleeve (Schefer, 1976).

The use of these 1/8" ID heated teflon lines was intended to minimize adsorption of species, such as NH_3 , which are known to have an affinity for cool surfaces.

3) Analytical Equipment

Catalyst temperatures were monitored using chromel-alumel thermocouples. The temperature of the upstream surface of the catalyst was measured using an optical pyrometer. Concentrations of CO and CO_2 were measured using non-dispersive infrared analyzers (NDIR's) which were equipped with water traps and particulate filters. Unburned hydrocarbons were monitored using flame ionization detection (FID). A chemiluminescent analyzer (CLA) was used to quantify NO. The errors which might be introduced by the relative third body quenching effect were compensated for using the equations presented by Matthews, et al. (1977). In this investigation, the important third bodies were CO_2 , H_2O , and Ar. Because Ar is less efficient than N_2 in quenching the relevant photochemical reaction and CO_2 and H_2O are more efficient, and because Ar is the major species in the products of combustion in this experiment, the relative quenching efficiencies compensated for each other. This resulted in the difference between actual and indicated NO concentrations never exceeding 5%.

EXPERIMENTAL RESULTS

One advantage of using an O_2/Ar mixture as the oxidant instead of air is that it allows investigation of catalytic combustion in a range of equivalence ratios which includes stoichiometric, $\phi = 1.0$. The melting point of this combustor is approximately 1420 K, a lower temperature than the temperature produced by propane/air combustion under

stoichiometric conditions. However, preliminary studies indicated that the temperatures produced during catalytic combustion under the conditions used in this study were much lower than the corresponding adiabatic flame temperatures indicating substantial heat loss. Figure 5 depicts the temperature distribution in the catalyst as a function of equivalence ratio. The temperature of the upstream face was determined using an optical pyrometer. During the course of the experiment, it was noted that the radiation from the upstream face of the catalyst was visibly more intense during fuel rich combustion. The curves in Figure 5 indicate that the temperature profile is very flat throughout the last half of the catalytic combustor.

Measured emissions of CO, CO₂, and UHC's are presented in Figure 6. Calculated equilibrium concentrations of CO and CO₂ are shown (dashed lines) for comparison. In a previous study, CO and CO₂ were emitted from a homogeneous combustion system (a flat flame burner) in concentrations which did not differ significantly from equilibrium predictions under fuel rich conditions (Sawyer, et al., 1976). For convenience, it may be assumed that the dashed curves in Figure 6 approximately represent homogeneous combustion while the solid curves depict trends observed during catalytic combustion. It is seen that the CO emitted from the catalytic combustor is much lower than predicted equilibrium values for all equivalence ratios investigated. For fuel rich combustion, CO₂ is emitted at levels which are greater than equilibrium. Measured UHC's (methane equivalent) decrease near stoichiometric and increase as the combustion process becomes richer. Of course, no unburned hydrocarbons are predicted for equilibrium conditions. An 85 - 95% carbon balance was obtained for all equivalence ratios.

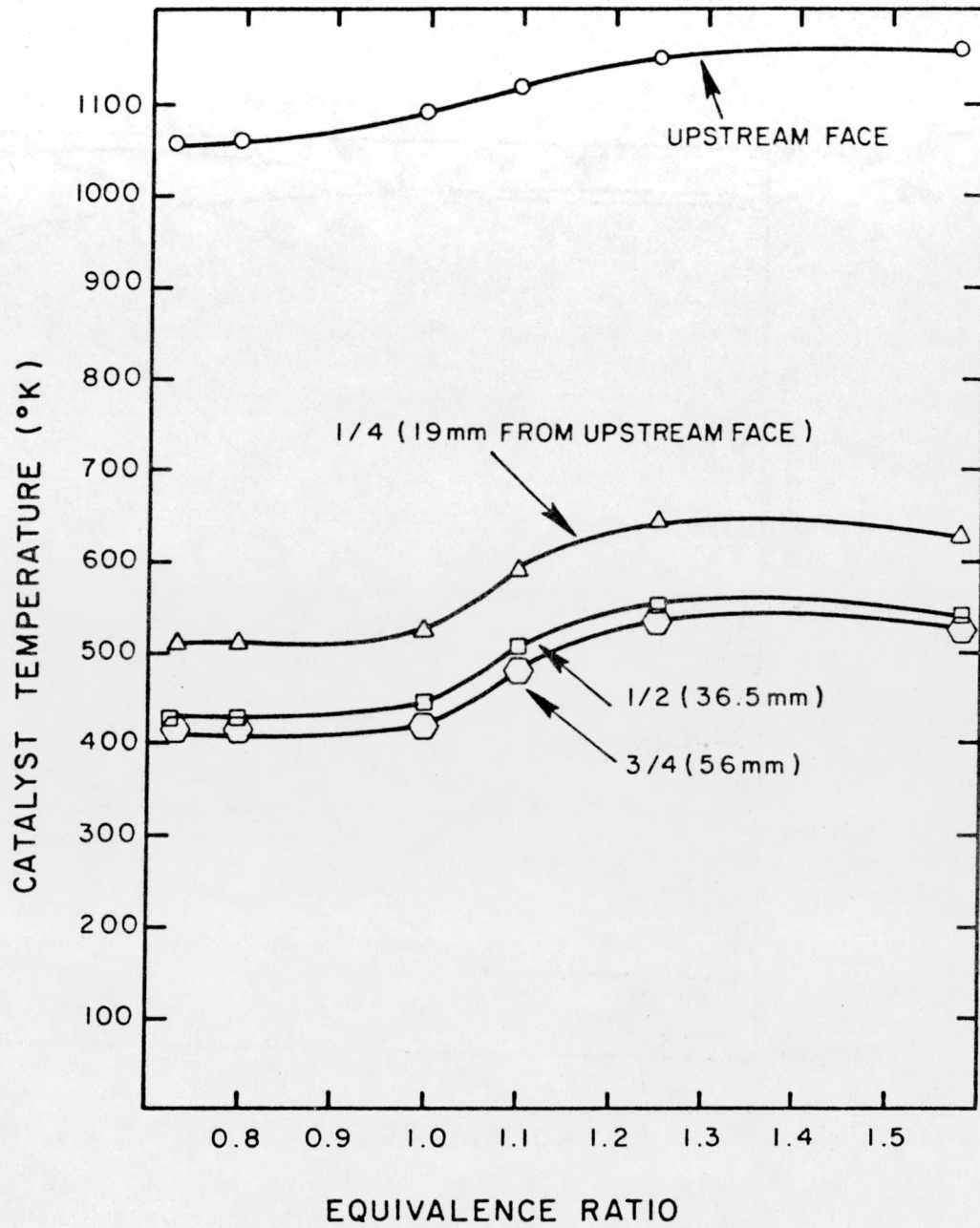

Figure 5. Temperature Distribution in the Catalyst as a Function of Equivalence Ratio.

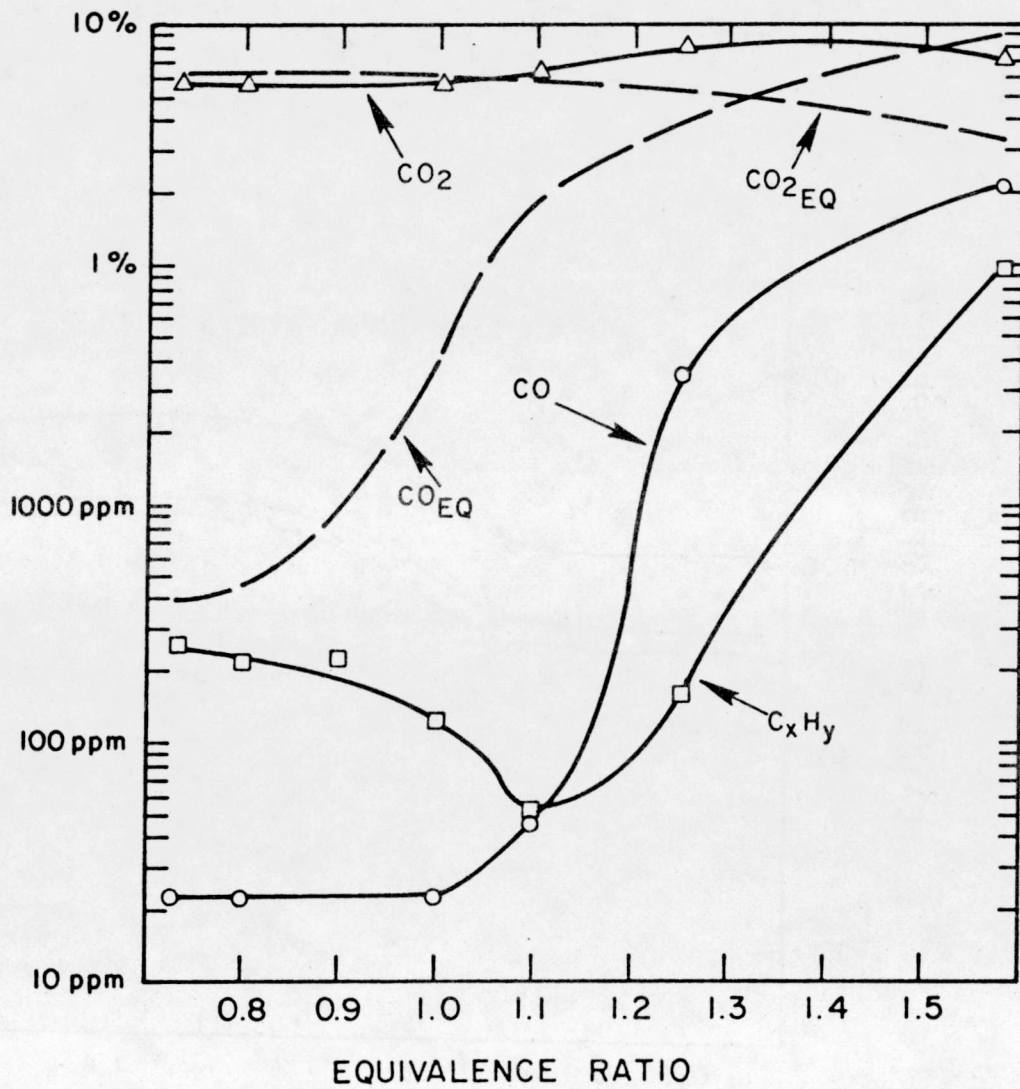

Figure 6. Comparison of Equilibrium and Measured Concentrations of CO, CO₂, and C_xH_y as a Function of Equivalence Ratio.

The measured CO, CO₂, and UHC concentrations allowed calculation of the combustion efficiency. The combustion efficiency may be generally defined as the ratio of the actual enthalpy released to the enthalpy which would be released during complete combustion. It is assumed that unburned hydrocarbons have the H/C ratio of propane. The combustion efficiency which is calculated from the measured emissions is compared graphically to the combustion efficiency for equilibrium products as a function of equivalence ratio in Figure 7. The catalytic combustor exhibits relatively high combustion efficiency for lean and stoichiometric combustion, though not as high as equilibrium products would show. However, for fuel rich operation, the combustion efficiency is much higher for catalytic combustion than for equilibrium conditions. This is because of the much higher CO₂ and lower CO in the measured products in comparison with the equilibrium values. Figure 8 is a plot of the NO yield (the fraction of the model fuel-N species which is converted to NO) as a function of equivalence ratio at constant temperature. The fuel nitrogen concentration was 5%. For NO addition, the calculated adiabatic flame temperature was 2024 K and for NH₃ was 2015 K. The NO yield using NH₃ as the model fuel nitrogen compound is higher than for NO as the model fuel-N species. The opposite is the case for gas phase combustion (Matthews, 1977).

Figure 9 shows the effect of fuel nitrogen concentration on the plot of NO yield versus equivalence ratio. The data for this graph were obtained with NH₃ addition at fuel nitrogen fractions of 5.0 wt. % and 1.75 wt. %.

In Figures 8 and 9, it is seen that the NO yield increases and reaches a maximum at about $\phi = 1$ and then drops to zero very rapidly.

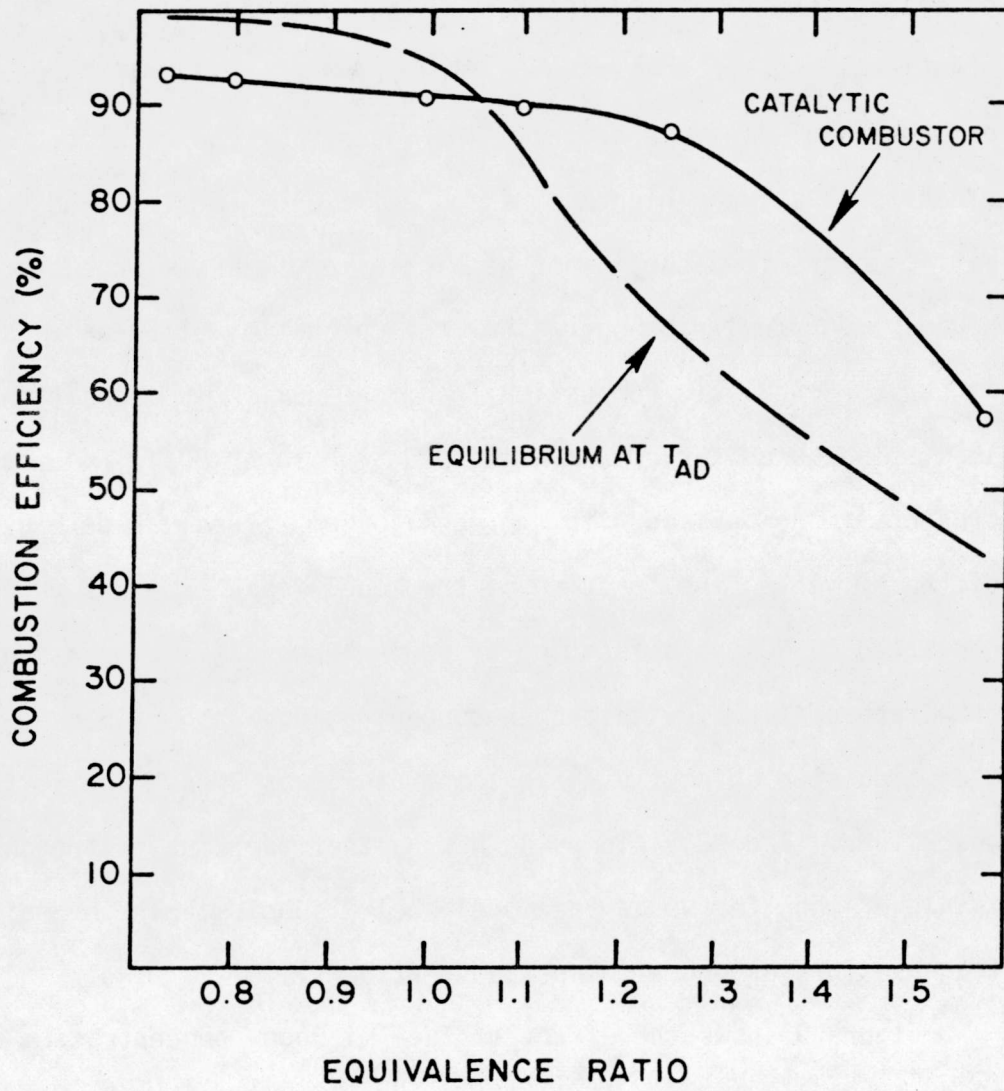

Figure 7. Combustion Efficiency as a Function of Equivalence Ratio.

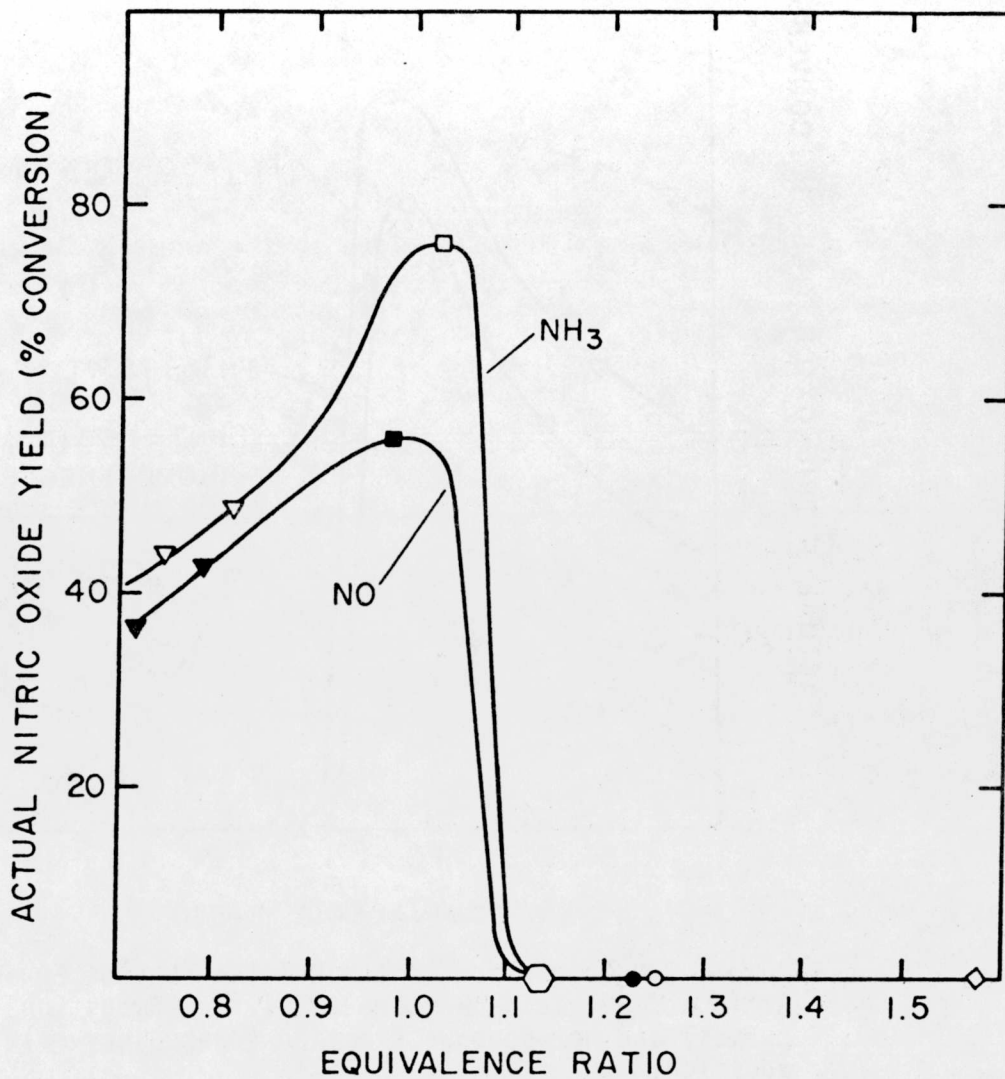

Figure 8. Effect of Equivalence Ratio on Conversion of Fuel-N to NO at Constant Adiabatic Flame Temperature and Fuel-N Concentration for Catalytic Combustion. [FN] = 5.0 wt. % of fuel, $T_{NO} = 2024$ K, $T_{NH_3} = 2015$ K.

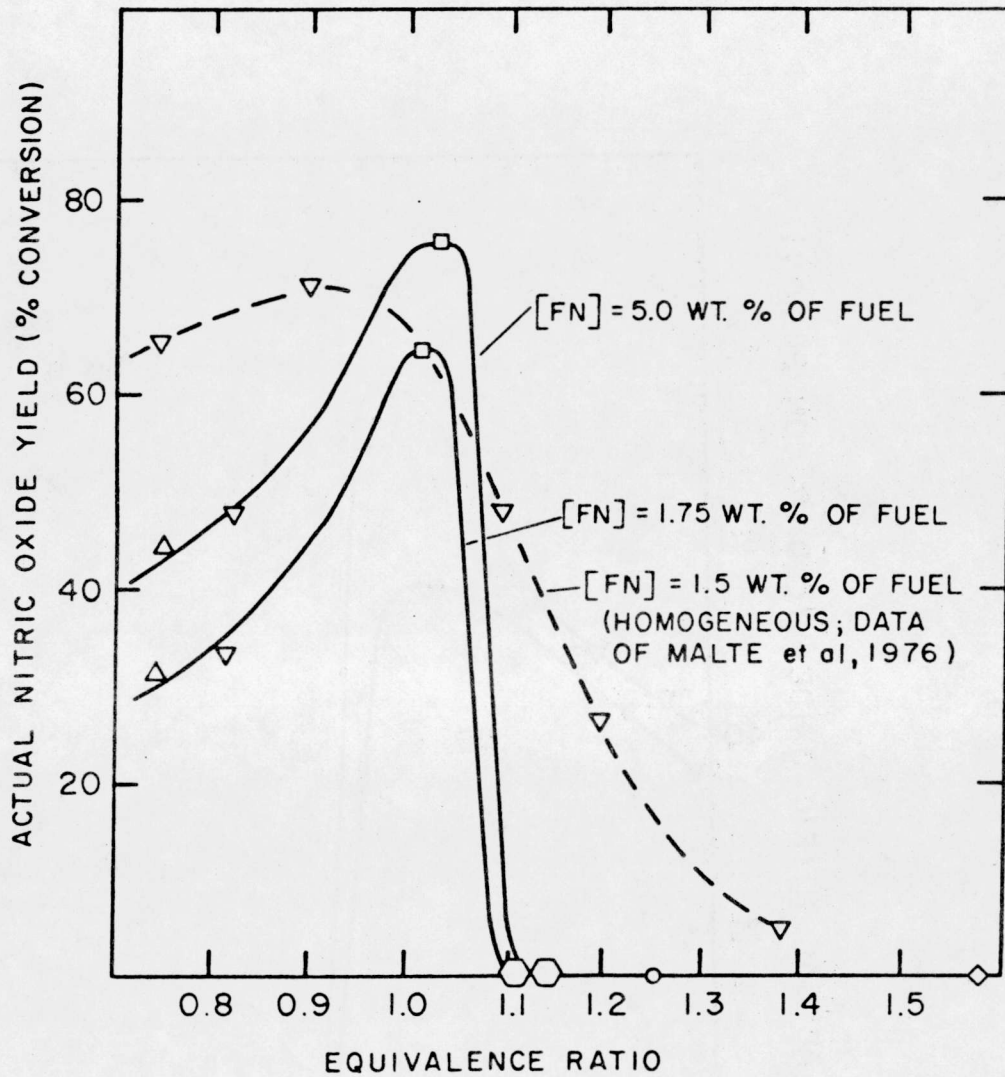

Figure 9. Comparison of the Relationship of Equivalence Ratio and NO yields Between Catalytic Combustion (solid curves) and Homogeneous Reaction (dashed curves). Ammonia addition.

Decreasing the fuel nitrogen concentration from 5% to 1.75% decreases the NO yield by approximately 10% for stoichiometric and fuel lean catalytic combustion. Because there is no NO produced for either fuel-N concentration, the effect of [FN] is insignificant for fuel rich catalytic combustion. The data obtained by Malte et al. (1976) for NH₃ addition to premixed C₃H₈/air combustion in a jet stirred reactor are also presented in Figure 9. The results of Axworthy and Schuman (1973) for NH₃ addition to premixed CH₄/O₂/Ar flat flames are in excellent agreement with Malte's JSR data. A comparison of the trends for catalytic combustion and homogeneous combustion (Malte's data) reveals that the NO yields for catalytic combustion are much lower except near stoichiometric. The decrease in NO yield for $\phi > 1$ is much more abrupt with catalytic combustion than with gas phase combustion. The NO yield in fuel lean catalytic combustion is significantly lower than for gas phase reaction.

The effect of fuel nitrogen fraction on the conversion of NH₃ to NO is presented in Figure 10. In the lean and stoichiometric cases, the NO yield increases with increasing fuel nitrogen concentration. For fuel rich catalytic combustion, the yield is independent of [FN] and equals zero. This is in striking contrast to the results of gas phase combustion, as depicted by the dashed curve of Figure 10. The dashed curve is the data taken using the flat flame burner. It has been well established that for both premixed and diffusion flames, the NO yield decreases with increasing [FN]. Exactly the opposite trend is exhibited by catalytic combustors.

Figure 11 shows that under near stoichiometric ($\phi = 1.03$) conditions, the NO yield is relatively independent of the adiabatic

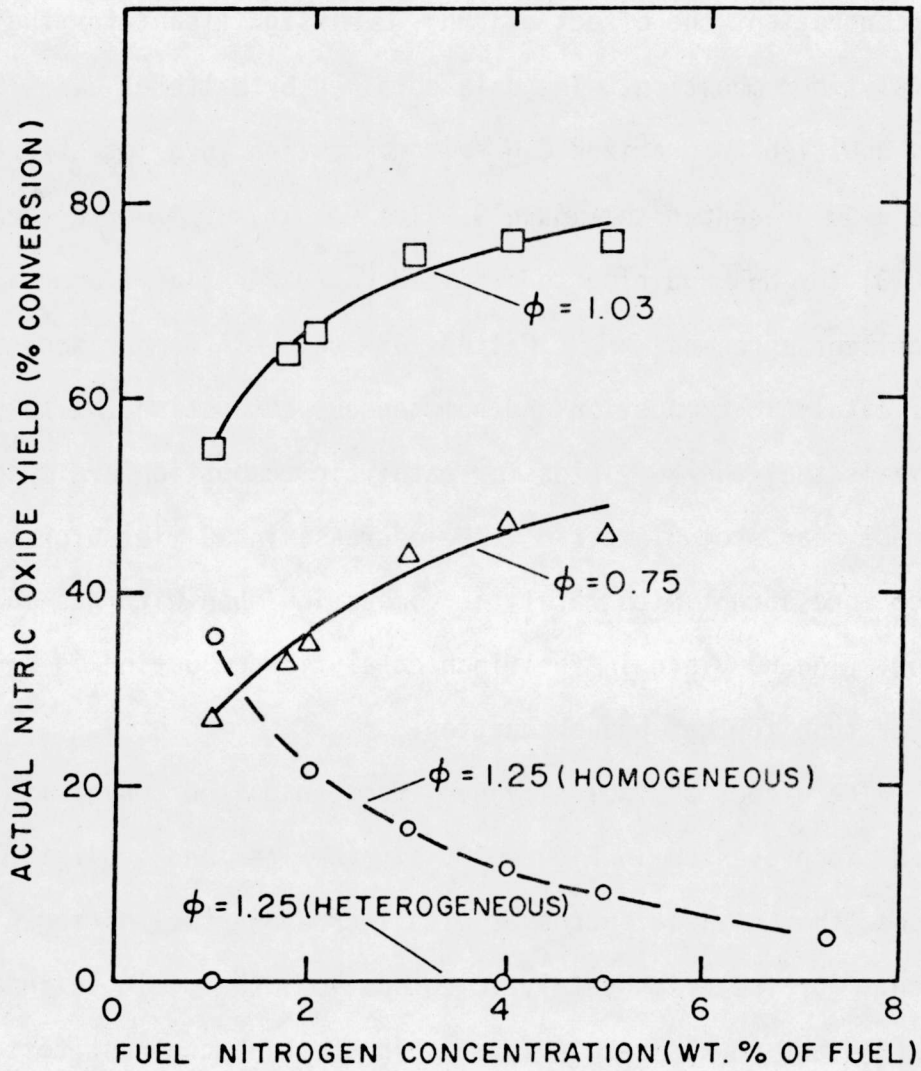

Figure 10. Effect of Fuel Nitrogen Concentration on the Conversion of NH_3 to NO at Constant Equivalence Ratio and Adiabatic Flame Temperature. In the fuel rich case, the flat flame burner data are compared with the catalytic combustor data.

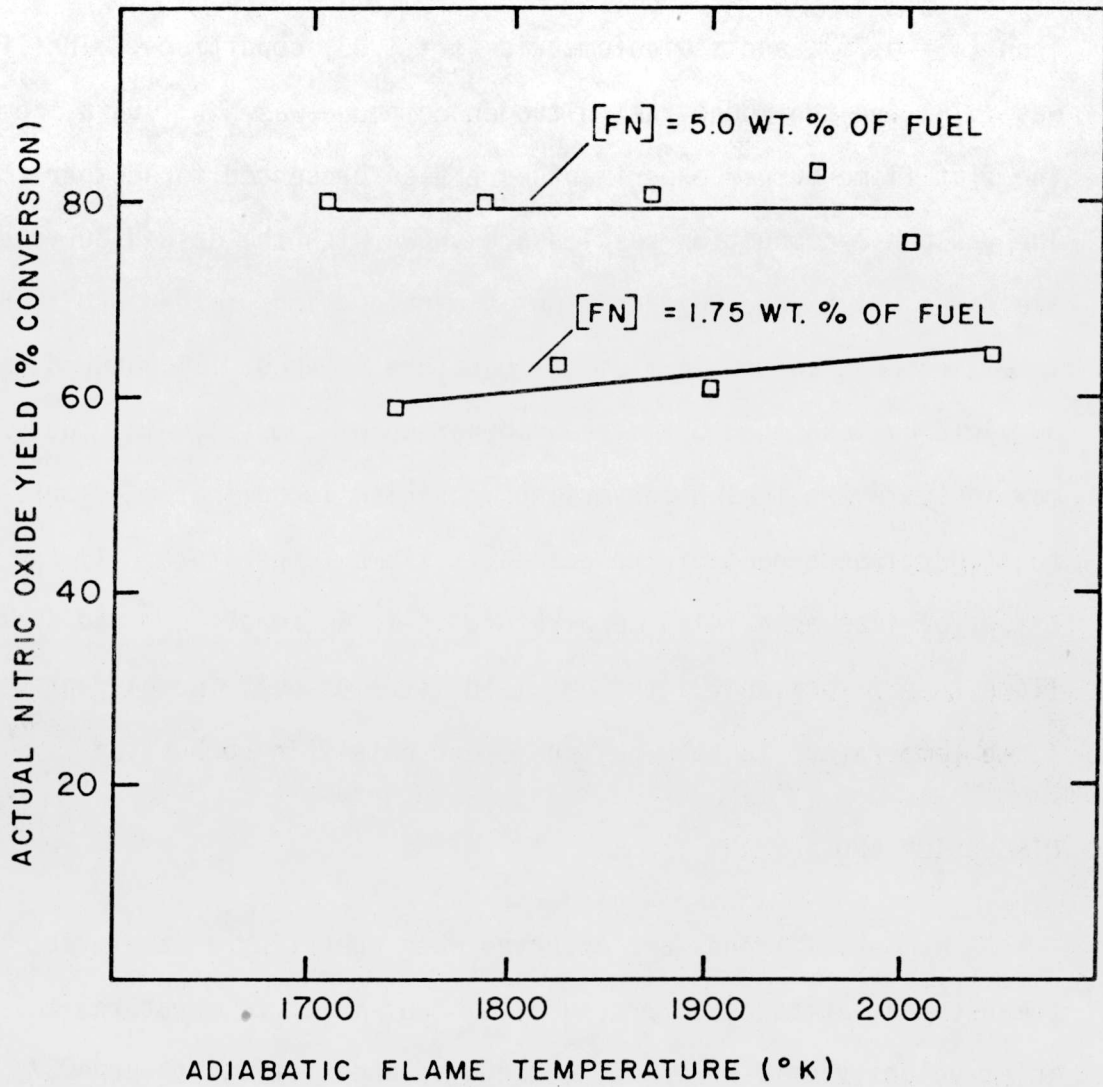

Figure 11. Effect of the Adiabatic Flame Temperature on the Conversion of NH_3 to NO for Two Fuel-N Concentrations at $\phi = 1.25$, Catalytic Combustion.

flame temperature. This is shown as a function of fuel nitrogen concentration for NH_3 addition at 5% and 1.75% by weight of the total fuel. Figure 12 demonstrates this same independence for rich ($\phi = 1.23$), lean ($\phi = 0.73$), and stoichiometric ($\phi = 1.03$) conditions. The [FN] was 1.75% and the model fuel nitrogen compound was NH_3 . Data from the flat flame burner experiments are also presented for comparison. The gas phase combustion results are shown with the dashed curve and are for $\phi = 1.23$ and NH_3 addition at a rate which yielded [FN] = 5.0%. In all cases a change in flame temperature of about 15% changed the NO yield by less than 5%. The combination of the following facts may indicate the fuel-N conversion mechanism is dominated by surface reactions independent of the adiabatic flame temperature: 1) the major effect of increased inlet temperature is to increase in the adiabatic flame temperature and 2) the NO yield is relatively independent of flame temperature in both gas phase and catalytic combustion.

DISCUSSION AND SUMMARY

A number of trends are observed when operating a catalytic combustor at atmospheric pressure, ambient inlet temperature, an inlet velocity of 0.05 m/sec, and equivalence ratios between 0.7 and 1.6.

The measured temperatures in the catalyst bed are significantly lower than the corresponding adiabatic flame temperatures. Increasing the equivalence ratio from 0.7 to 1.6 at constant theoretical adiabatic flame temperature resulted in an increase in catalyst temperature of less than 20% with the temperature being uniform with equivalence ratio for $\phi < .9$ and a higher uniform temperature for $\phi > 1.25$. The axial

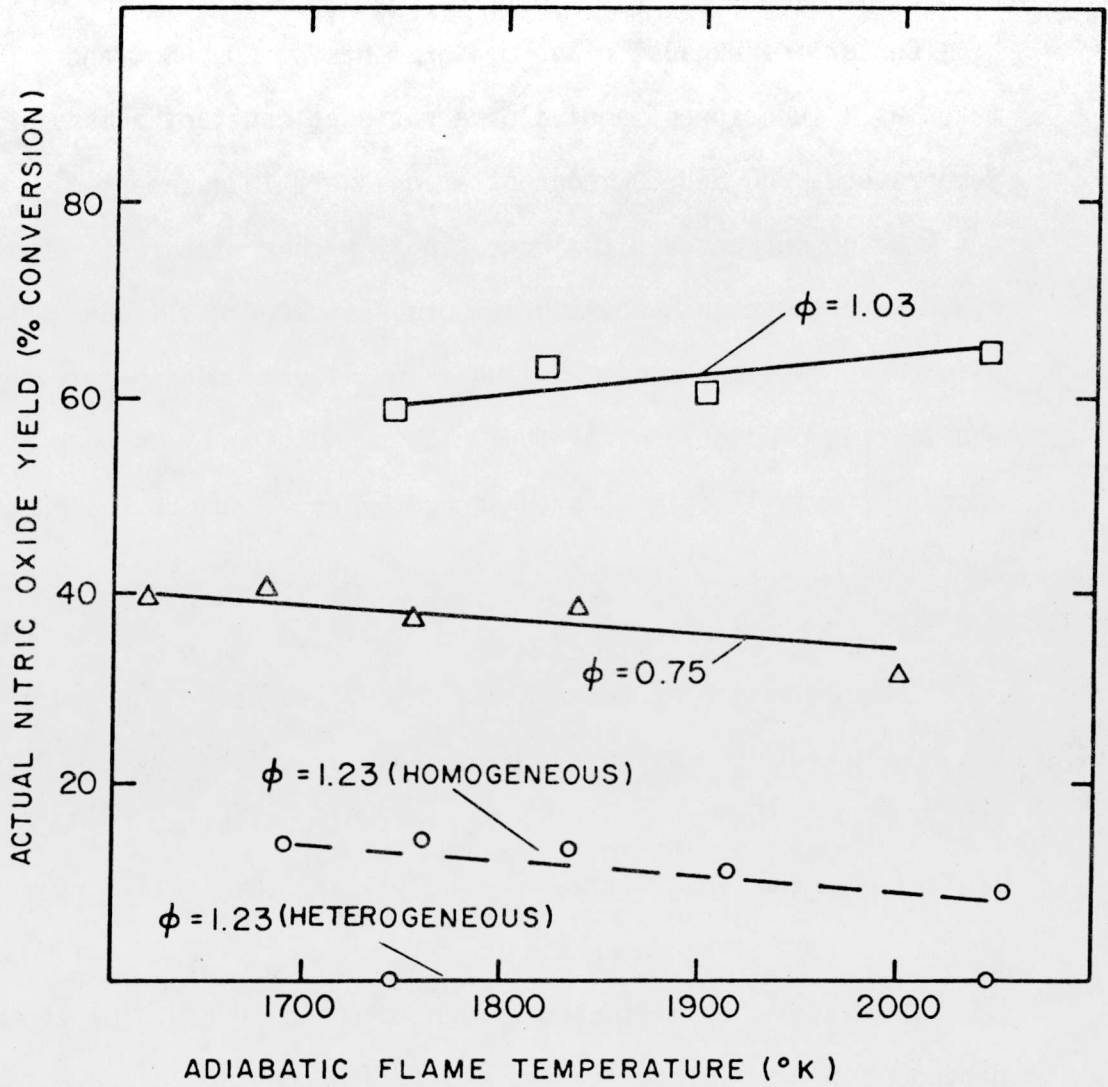

Figure 12. Effect of the Adiabatic Flame Temperature on the Conversion of NH_3 to NO for Lean, Stoichiometric and Rich Catalytic Combustion.

temperature distribution in the catalyst revealed that the temperature gradient was steepest in the first 25% of the catalyst length. This indicates that the reaction occurred primarily near the entrance to the catalyst.

Centerline exhaust plane measurements of CO, CO₂, and UHC's were taken as a function of equivalence ratio at constant adiabatic flame temperature. CO and CO₂ concentrations were independent of ϕ for $\phi < 1.0$ and increased with increasingly richer mixtures. Emissions of CO were lower than equilibrium predictions for all conditions by as much as two orders of magnitude. CO₂ levels were higher than equilibrium predictions for fuel rich combustion by as much as a factor of two. The level of unburned hydrocarbons decreased with increasing ϕ until it reached a minimum at approximately $\phi = 1.1$ and then rose sharply.

The combustion efficiency was calculated using the measured CO, CO₂, and UHC emissions. The combustion efficiency was significantly higher than it would have been for equilibrium products for fuel rich combustion. It was slightly lower than equilibrium predictions for lean combustion.

The conversion of fuel nitrogen to NO is found to be strongly dependent on equivalence ratio, weakly dependent on calculated adiabatic flame temperature, and moderately dependent on fuel nitrogen concentration. The NO yield increases with increasing equivalence ratio and reaches a maximum at about $\phi = 1$. It then drops to zero very rapidly. The NO yield is much lower for catalytic combustion than for gas phase combustion for all equivalence ratios except near stoichiometric. The NO yield increases with increasing fuel nitrogen

fraction for lean and stoichiometric catalytic combustion and equals zero for rich catalytic combustion. This contrasts sharply with the behavior reported for homogeneous combustion systems, in which case the NO yield decreased with increasing fuel nitrogen fraction for lean, stoichiometric, and rich flames. Another contrast between catalytic and homogeneous combustion involves the relative conversion efficiencies of NH_3 and NO in the fuel to NO in the products. In homogeneous combustion systems, NH_3 is converted less efficiently and in catalytic combustion systems it is converted more efficiently than is NO. This may be partially attributable to the nature of each species, NH_3 being a fuel while NO is an oxidant. These contrasts indicate that the fuel nitrogen conversion mechanism may be dominated by surface reactions during catalytic combustion. The NO yield is relatively independent of the adiabatic flame temperature for both gas phase and catalytic combustion.

Further research is necessary to determine the effect of pressure, inlet temperature, and inlet velocity on the catalyst temperature, emissions of CO, CO_2 , UHC's, thermal NO, combustion efficiency and fuel nitrogen conversion mechanism. The precise fate of the fuel nitrogen remains to be determined.

ACKNOWLEDGEMENTS

Mr. Al Shaw of the Department of Mechanical Engineering designed and constructed the probe controller. This work was supported in part by ERDA through Contract No. W-7405-ENG-48.

REFERENCES

- Appleton, J.P. and Heywood, J.B. (1973). The effects of imperfect fuel-air mixing in a burner on NO formation from nitrogen in the air and the fuel. Fourteenth Symposium (International) on Combustion, 777.
- Axworthy, A.E. and Schuman, M. (1973). Investigation of the mechanism and chemistry of fuel nitrogen conversion to nitrogen oxides in combustion. Presented at the Coal Combustion Symposium, Environmental Protection Agency, Research Triangle Park, North Carolina.
- Cavender, J.H., Kircher, D.S. and Hoffman, A.F. (1973). Nationwide Air Pollutant Emission Trends 1940-1970. U.S. Environmental Protection Agency, Research Triangle Park, North Carolina.
- Gaynor, J., editor (1976). Monthly Energy Review. Federal Energy Administration. NTIS UB/B/127-76-011, November.
- Malte, P.C., Halgren, C.A., Monteith, L.E., Corlett, R.C. and Pratt, D.T. (1976). The fate of organic nitrogen in jet-stirred combustion. Fall Meeting, Western States Section, The Combustion Institute, La Jolla, California.
- Matthews, R.D. (1977). The nature and formation of nitrogenous air pollutant emissions from combustion systems. Ph.D. Thesis, Department of Mechanical Engineering, University of California, Berkeley.
- Matthews, R.D., Sawyer, R.F. and Schefer, R.W. (1977). Interferences in the chemiluminescent measurement of NO and NO₂ emissions from combustion systems. Environmental Science and Technology (in press).
- Sarofim, A.F. and Flagan, R.C. (1976). NO_x control for stationary combustion sources. Prog. Energy Combustion Sci. 2, pp. 1-25.
- Sawyer, R.F., Brown, N.J., Matthews, R.D., Branch, M.C. and Banna, S.M. (1976). The formation of nitrogen oxides from fuel nitrogen. Electric Power Research Institute, Report EPRI 223-1.
- Schefer, R.W. (1976). Pollutant formation in recirculating reacting flows. Ph.D. Thesis, Department of Mechanical Engineering, University of California, Berkeley.

This report was done with support from the Department of Energy. Any conclusions or opinions expressed in this report represent solely those of the author(s) and not necessarily those of The Regents of the University of California, the Lawrence Berkeley Laboratory or the Department of Energy.

TECHNICAL INFORMATION DEPARTMENT
LAWRENCE BERKELEY LABORATORY
UNIVERSITY OF CALIFORNIA
BERKELEY, CALIFORNIA 94720