

**MASTER**

There is no objection from the patent  
point of view to the publication of  
disclosure of the data and material  
listed in this report.

PROCESSED BY PATENT GROUP  
1/18 1978 BY ell

 **Thermo  
Electron**  
CORPORATION

DISTRIBUTION OF THIS DOCUMENT IS LIMITED

## **DISCLAIMER**

**This report was prepared as an account of work sponsored by an agency of the United States Government. Neither the United States Government nor any agency Thereof, nor any of their employees, makes any warranty, express or implied, or assumes any legal liability or responsibility for the accuracy, completeness, or usefulness of any information, apparatus, product, or process disclosed, or represents that its use would not infringe privately owned rights. Reference herein to any specific commercial product, process, or service by trade name, trademark, manufacturer, or otherwise does not necessarily constitute or imply its endorsement, recommendation, or favoring by the United States Government or any agency thereof. The views and opinions of authors expressed herein do not necessarily state or reflect those of the United States Government or any agency thereof.**

## **DISCLAIMER**

**Portions of this document may be illegible in electronic image products. Images are produced from the best available original document.**

ERDA/NASA  
ADVANCED THERMIONIC  
TECHNOLOGY PROGRAM  
PROGRESS REPORT NO. 27

**NOTICE**  
This report was prepared as an account of work sponsored by the United States Government. Neither the United States nor the United States Department of Energy, nor any of their employees, nor any of their contractors, subcontractors, or their employees, makes any warranty, express or implied, or assumes any legal liability or responsibility for the accuracy, completeness or usefulness of any information, apparatus, product or process disclosed, or represents that its use would not infringe privately owned rights.

September 1977

ERDA Contract EY-76-C-02-3056  
NASA Contract NAS3-20959

Prepared By  
Thermo Electron Corporation  
101 First Avenue  
Waltham, Massachusetts 02154

## I. SURFACE STUDIES

### A. SURFACE THEORY

No work was performed on this task during this reporting period.

### B. SURFACE CHARACTERIZATION CHAMBER

Samples from several surface characterization experiments underwent chemical analysis by Auger spectroscopy. Results are given in pertinent sections of this report.

### C. ACTIVATION CHAMBER EXPERIMENTS

The suspiciously low bare work function values reported last month for sprayed  $\text{LaB}_6$  were found to be caused by trace amounts of BaO impurities on the RCA-Vidicon nickel substrates used. Since this compound has a work function of about 1.6 eV a residue covering less than  $10^{-4}$  of the substrate area is sufficient to give a thermionic emission current corresponding to the work function measured with sprayed  $\text{LaB}_6$ .

The Vidicon guns are supplied with a standard barium carbonate coating and the coating is removed with alcohol before the nickel substrate is used for the experiments in the Activation Chamber. The following experiments lead to the conclusion that, after wiping off the deposit, traces of the carbonate may be left on the sidewall of the gun which is not coated with  $\text{LaB}_6$ :

1. A nickel substrate was etched with HCl prior to depositing the  $\text{LaB}_6$ . A work function above 3 eV was obtained with this surface.
2. After wiping off the  $\text{BaCO}_3$ , a nickel substrate was examined by Auger spectroscopy and traces of barium were observed.
3. A molybdenum substrate was sprayed with  $\text{BaCO}_3$  and the coating was removed in the conventional manner. Low work function was measured and barium was again detected by Auger spectroscopy.

These bare work function results should not be confused with the values below 1.1 eV measured for  $\text{LaB}_6$  activated with cesium and oxygen. Such low values were measured irrespective of the substrate on which the  $\text{LaB}_6$  was deposited.

## II. PLASMA STUDIES

### A. CONVERTER THEORY

No work was performed on this task during this reporting period.

### B. ENHANCED MODE CONVERSION EXPERIMENTS

In order to reduce electron space charge effects sufficiently in close spaced diodes with rigid electrodes, surface distortion must remain well below 0.1 mil ( $25\mu\text{m}$ ). Quantitative estimates were made of such distortion by observing the reflected profile of a He-Ne laser beam incident on a laser mirror electrode during heating. Aiming the 1 mm beam at an incident grazing angle of  $83^\circ$  produced an 8 mm long intersection line between the ray and the surface of the sample. The reflected beam was observed on a screen placed approximately 20 m away. Monitoring the spot size while the sample electrode was being heated to 1500 K did not indicate any significant thermal distortion. Thermal deformation of the structure supporting the sample did, however, significantly affect the observations. Consequently, more refined measurements will be performed with a double beam system wherein the first beam is reflected from the center of the sample and the second from its edge. Measurement of the distance between these beams, as a function of sample temperature, will provide a better determination of the thermal distortion of the electrode surface at emitter temperatures.

### III. CONVERTER DEVELOPMENT

#### A. LOW TEMPERATURE CONVERSION EXPERIMENTS

##### 1. Tungsten Emitter, Lanthanum Hexaboride Collector (Converter No. 180).

In an effort to characterize lanthanum hexaboride as a collector material, a variable spacing converter was built employing a standard electropolished tungsten emitter with a sprayed lanthanum hexaboride collector. A guarded collector was used to obtain accurate work function measurements from dc back-emission data at low current values. The guard (Figure III-1) is designed to eliminate emission from the collector and to lower emitter-to-collector leakage current. The collector surface was prepared by spraying an approximately 2.5  $\mu\text{m}$  thick coating of lanthanum hexaboride suspended in organic binder onto a molybdenum collector assembly. The binder was subsequently evaporated by heating the collector to 675 K during the degassing of the converter. Sprayed, rather than sintered, material was chosen to simplify fabrication by eliminating several brazing steps. Backemission collector work function versus  $T_C/T_R$  is shown in Figure III-2. Work functions as low as 1.45 eV were obtained at  $T/T_R$  values between 1.4 and 1.5. Measurements were made at a constant  $T_R$  for several different collector temperatures. No significant temperature dependence was noted. Correlation between back-emission data and retarding plots will be made during the next reporting period.

#### B. HIGH EFFICIENCY CONVERSION EXPERIMENTS

##### 1. Tungsten Emitter, Lanthanum Hexaboride Collector ("Showerhead" Converter No. 166)

Several experiments were performed in which oxygen was diffused through the porous "showerhead" collector during ignited mode operation. The emitter temperature was held constant at 1400 K with a fixed electrode

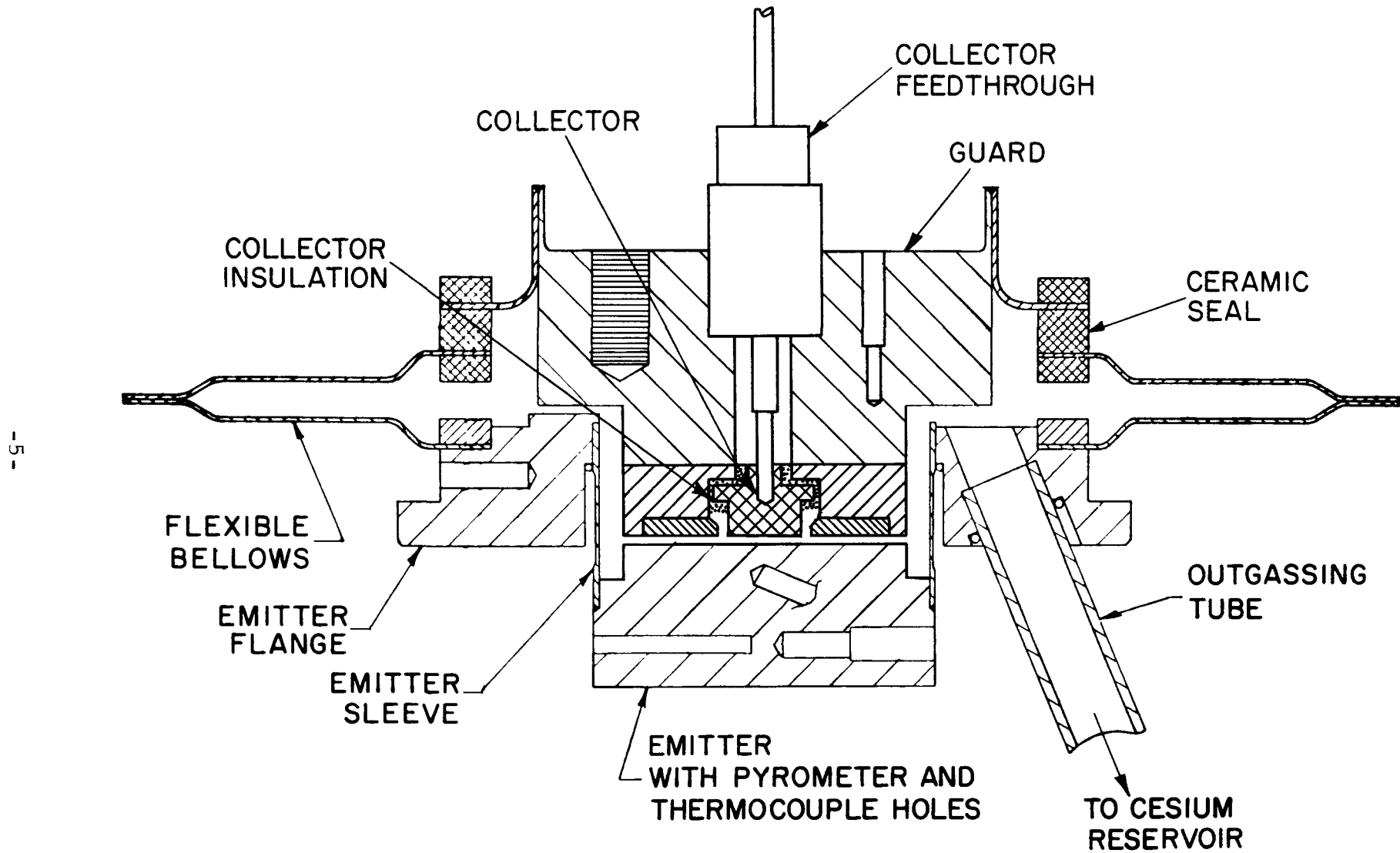

Figure III-1 Schematic of Guarded Converter

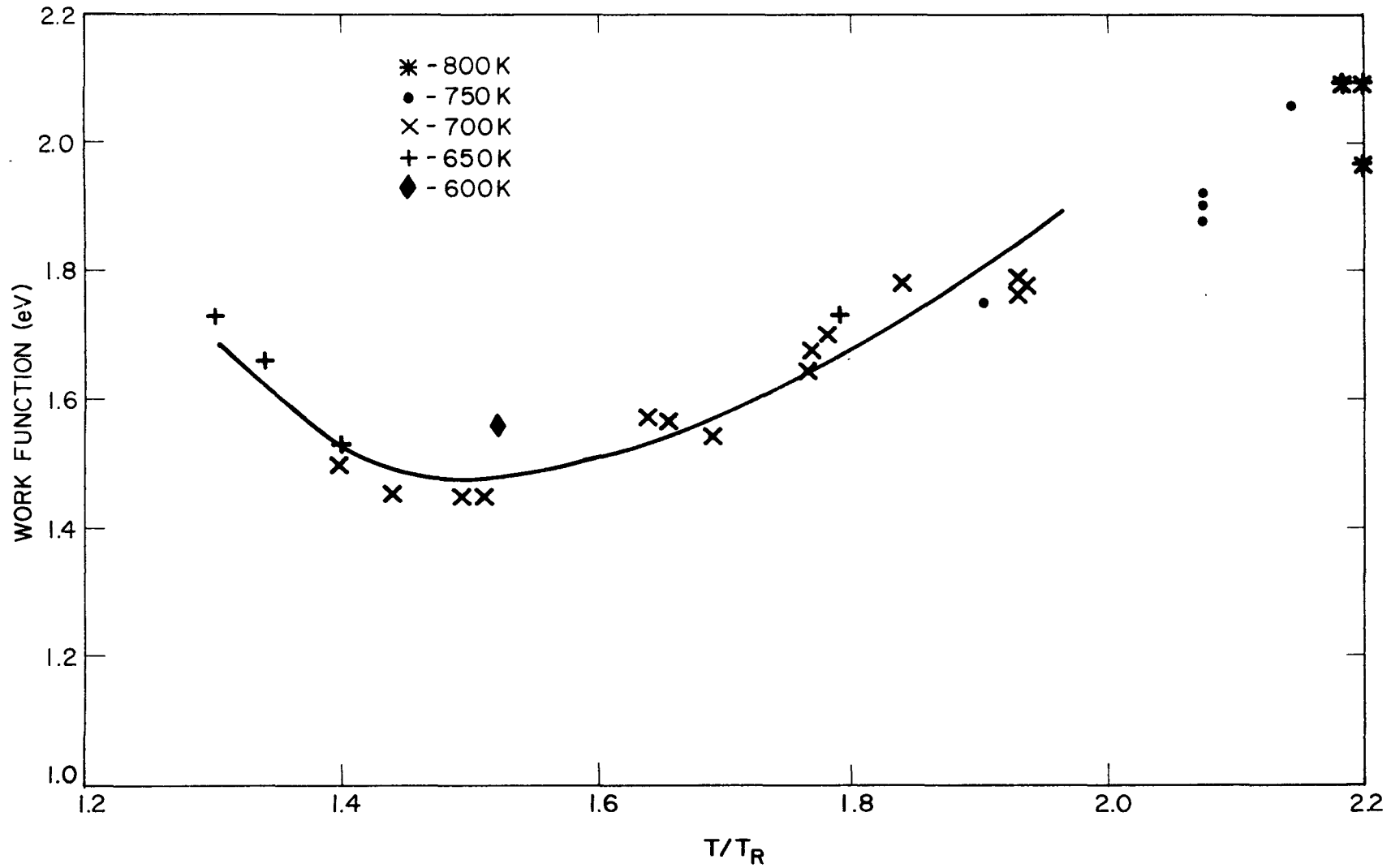

Figure III-2. Work Function of Sprayed Lanthanum Hexaboride Collector Versus  $T/T_R$   
(data from dc back-emission)

spacing of 2.5 mm. Both the collector temperature and the cesium reservoir temperature were independently varied in an attempt to find the minimum oxygen pressure behind the showerhead required to enhance the performance of the converter. Typically 1 to 2 torr of oxygen was necessary for a cesium pressure of  $5 \times 10^{-2}$  torr in the converter and a collector temperature of 850 K. In these experiments a change in either the emitter saturation current or the back ignited current from the collector was used as an indication of oxygen penetration into the converter. In all cases such penetration de-ignited the converter. As the oxygen was pumped out through the porous collector re-ignition with enhanced performance was observed. Saturation currents from both the emitter and collector were increased by factors of 2 to 3. These larger currents would return to their original values in about 30 minutes.

#### IV. COMPONENT HARDWARE PROGRAM

##### A. HOT SHELL DEVELOPMENT

Three CVD tungsten shells were fabricated, each at a different tungsten hexafluoride flow rate. The properties of these shells are compared in Table IV-1. For the higher  $WF_6$  flow rates, the tungsten coatings were smooth and gave no indication of faceting.

The exhaust-gas scrubber was slightly modified. Polyethylene balls were added to the 10 N KOH scrubbing solution in order to restrict bubble size and impede their upward flow. The result is a more thorough scrubbing of exhaust gases.

Simulated furnace testing continued at a furnace gas temperature of 1573 K (2370 F). The inside of the shells is evacuated to  $10^{-7}$  torr. Table IV-2 presents the status of these tests as of October 5, 1977. A leak was observed on the chromized 446 CRES sample on September 27, 1977. This shell was subsequently removed from the furnace for failure analysis.

Table IV-1

## CVD Tungsten Shells

Run Number	Duration of Run (Min.)	Shell Number	WF <sub>6</sub> Flow Rate (SCCM)	Coating Thickness	
				Hemisphere	Wall
7	78	W2	50	0.012 "	0.004 "
8	85	W2	100	0.018 " (net)	0.010 " (net)
9	85	W3	150	0.023 "	0.012 "
10	75	W4	200	0.018 "	0.011 "

TABLE IV-2

SIMULATED FURNACE TESTS  
(5 Oct. 1977)

HOT SHELL	TEST HOURS	COMMENT	DATE OF TEST INITIATION
REACTION BONDED SILICON CARBIDE	13, 733	LEAKTIGHT THIS HOT SHELL WAS BRAZED TO A MOLYBDENUM SLEEVE WITH NICKEL-COPPER	9 April 75
KANTHAL A1	12, 146	LEAKTIGHT	25 Aug. 75
KANTHAL A1	12, 012	LEAKTIGHT	9 Sept. 75
INCONEL 671	5, 183	LEAKTIGHT	17 Nov. 76
CHROMIZED STAINLESS STEEL 446	5, 172	LEAK OBSERVED REMOVED 27 SEPT. 1977	17 Nov. 76
KANTHAL A1	2, 330	LEAKTIGHT	7 May 77