

348  
7-3-80  
JWA

1438

DOE/NASA CONTRACTOR  
REPORT

**MASTER**

DOE/NASA CR-161443

SOLAR HEATING AND HOT WATER SYSTEM INSTALLED AT MUNICIPAL  
BUILDING COMPLEX, ABBEVILLE, S. C. - FINAL REPORT

Prepared by

Gilliland-Bell Associates, Inc.  
Greenwood, SC

Under Contract DOE EM-78-F01-5202

National Aeronautics and Space Administration  
George C. Marshall Space Flight Center, Alabama 35812

For the U. S. Department of Energy

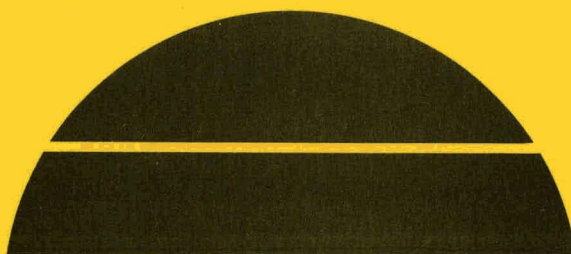

**U.S. Department of Energy**



**Solar Energy**

DISTRIBUTION OF THIS DOCUMENT IS UNLIMITED

NOTICE

This report was prepared to document work sponsored by the United States Government. Neither the United States nor its agents the United States Department of Energy, the United States National Aeronautics and Space Administration, nor any federal employees, nor any of their contractors, subcontractors or their employees, make any warranty, express or implied, or assume any legal liability or responsibility for the accuracy, completeness, or usefulness of any information, apparatus, product or process disclosed, or represent that its use would not infringe privately owned rights.

1. REPORT NO. DOE/NASA CR-161443		2. GOVERNMENT ACCESSION NO.		3. RECIPIENT'S CATALOG NO.	
4. TITLE AND SUBTITLE Solar Heating and Hot Water System Installed at Municipal Building Complex, Abbeville, SC - Final Report				5. REPORT DATE November 1979	
				6. PERFORMING ORGANIZATION CODE	
7. AUTHOR(S)				8. PERFORMING ORGANIZATION REPORT #	
9. PERFORMING ORGANIZATION NAME AND ADDRESS Gilliland-Bell Associates, Inc. Greenwood, SC				10. WORK UNIT NO.	
				11. CONTRACT OR GRANT NO. EM-78-F01-5202	
12. SPONSORING AGENCY NAME AND ADDRESS U. S. Department of Energy Conservation and Solar Energy Washington, DC 20585				13. TYPE OF REPORT & PERIOD COVERED  Contractor Report	
				14. SPONSORING AGENCY CODE	
15. SUPPLEMENTARY NOTES This work was done under the technical management of Mr. Val Fogle, National Aeronautics and Space Administration, Marshall Space Flight Center, Alabama.					
16. ABSTRACT  This document provides information on the solar energy system installed at the new Municipal Building for the City of Abbeville, SC. The information consists of description of solar energy system and building, photographs, system performance, operation manual, as-built drawings, lessons learned and recommendations.  The solar space heating system is a direct air heating system. The flat roof collector panel was sized to provide 75% of the heating requirement based on an average day in January. The collectors used are job-built with two layers of filon corrugated fiberglass FRP panels cross lapped make up the cover. The storage consists of a pit filled with washed 3/4" - 1 1/2" diameter crushed granite stone. The air handler includes the air handling mechanism, motorized dampers, air circulating blower, sensors, control relays and mode control unit. Solar heating of water is provided only during those times when the hot air in the collector is exhausted to the outside.					
17. KEY WORDS			18. DISTRIBUTION STATEMENT UC-59a Unclassified-Unlimited  <i>William A. Brooksbank Jr</i> WILLIAM A. BROOKSBANK, JR. Mgr., Solar Energy Applications Proj.		
19. SECURITY CLASSIF. (of this report)  Unclassified		20. SECURITY CLASSIF. (of this page)  Unclassified		21. NO. OF PAGES  52	22. PRICE  NTIS

## TABLE OF CONTENTS

	<u>PAGE</u>
1. Narrative Description of Solar Energy System and Building	1
2. Acceptance Test Data	3
a. Acceptance Test Plan	
b. Acceptance Test Results	
3. As-Built Drawings	4
4. Operation and Maintenance Manual	4
a. Manufacturer's Literature	
b. Operating Mode Table and Control Logic Narrative	
5. Photographs of Final Installation	5
6. Predicted System Performance Data	9
7. Major Problems Encountered	19
8. Lessons Learned and Recommendations	19
9. Verification Statements	20
a. As-Built Drawings	
b. Acceptance Test Plan	
c. Interim Performance Criteria	
APPENDIX A	Acceptance Test Plan
APPENDIX B	As-Built Drawings
APPENDIX C	Operation Manual

### DISCLAIMER

This book was prepared as an account of work sponsored by an agency of the United States Government. Neither the United States Government nor any agency thereof, nor any of their employees, makes any warranty, express or implied, or assumes any legal liability or responsibility for the accuracy, completeness, or usefulness of any information, apparatus, product, or process disclosed, or represents that its use would not infringe privately owned rights. Reference herein to any specific commercial product, process, or service by trade name, trademark, manufacturer, or otherwise, does not necessarily constitute or imply its endorsement, recommendation, or favoring by the United States Government or any agency thereof. The views and opinions of authors expressed herein do not necessarily state or reflect those of the United States Government or any agency thereof.

## 1. Narrative Description of Solar Energy System and Building

The solar energy system is for the new Municipal Building for the City of Abbeville, S. C. The two-story brick structure houses the Police Department, Fire Department, and Recorder's Court in this very old and historical city. The Police Department and Recorder's Court facilities are located entirely on the first floor. The Fire Department's offices and apparatus room are also on the first floor. Dayroom and dormitory facilities for the firemen occupy the second floor where the mechanical equipment room is also located. The building structure consists of steel roof bar joists on masonry walls at the first floor and steel roof and floor bar joists on steel framing for the second floor. The floors throughout the facility are concrete slabs.

The building site is a narrow and deep plot located just off the main city square on South Main Street. The street is on the east side of the site, and a small hardware store is adjacent to the north side. A residence on the west side and a residence on the south side do not create any shade that could interfere with the solar energy collection.

The building design was required to be compatible with existing buildings in the Historical District (entire city), and it has been approved by the State and Local Historical Societies. This predicated no use of solar equipment that would affect the general appearance of the building. The flat roof collector panel is a very economical system which meets the criteria for not affecting the appearance of the building. The size of the collector panels was based on providing 75% of the required BTU/HR needed to heat the building on an average day in January. The solar space heating is actually involved in heating only a portion of the building. The Courtroom is on a separate system due to its infrequent use. The apparatus room does not require space heating and has an infrared heater system that heats the equipment in the room at a much lower temperature than other spaces.

The space heating solar system is a direct air heating system. The collectors used in this project are job-built collectors. Two layers of filon corrugated fiberglass FRP panels cross lapped make up the cover. The top layer of fiberglass is "Tedlar" coated. The layers of panels are attached to 2 x 4 nailers on the top surface of the roof's structural steel bar joists. The absorber plate consists of 1" fiberglass ductliner (Certain Teed-CSG) and is attached to the bottom of the bar joists. One half of the collector area provided is located on the second floor roof and the remaining half is located on a portion of the first floor roof of the building. Heated air is transmitted through a duct system to the air handler for distribution to the building or storage pit.

The air handler includes the air handling mechanism, complete with motorized dampers, air circulating blower, blow motor, sensors, solid state control relays and the mode control unit. The mode control unit is programmed to control the collection, storage and distribution of solar heat and natural cooling by means of strategically located sensors; it coordinates the solar and backup systems by constant monitoring of the air from the outside, collector, building, and storage, to provide optimum performance and maintain the desired temperature.

The storage consists of a pit below a portion of the building first floor slab filled with 3/4 - 1 1/2" diameter crushed granite stone that has been washed for solar use. The side walls of the pit are concrete block and the bottom is a concrete slab. The pit is sealed by vapor barriers to prevent moisture infiltration and is equipped with a drain as a safety precaution.

The domestic hot water system consists of a hot water storage tank and heat exchanger. Solar heating of water is provided only during those times when the hot air in the collector is exhausted to the outside. Water from the storage tank is circulated through the heat exchanger located in the system exhaust air duct. When hot water usage occurs pre-heated water from the hot water storage tank is circulated to the building's electric hot water heater where additional heat is provided (if required) and distributed to the building.

Natural cooling modes are provided to supplement the air conditioning cycle of the building heat pump systems. Air in the building is circulated by the solar system air handler through the rock storage pit allowing the rock to absorb heat from the air. When the outside air temperature drops less than the temperature of the rock storage, the air handler circulates outside air over the rock and exhausts heat absorbed from the rock to the exterior of the building.

## 2. Acceptance Test Data

a. Acceptance Test Plan - See Inserts. - Appendix A

b. Acceptance Test Results

The following readings were taken in the Acceptance Test:

### Fan Power Measurements

Zone 1 - Heat Pump Fan Motor (3/4 HP)  
218 volts @ 3.7 amps.  
- Solar Air Handler Motor (2 HP)  
128 volts @ 16.5 amps.

Zone 2 - Heat Pump Fan Motor (3/4 HP)  
218 volts @ 2.5 amps.

Domestic Hot Water - Air Coil Water Circulator Motor  
128 volts 1.4 amps.

Summer Collector Exhaust Fan - 128 volts @ 13.0 amps.

### Air Flow Measurements

Zone 1 - Return Air = 1665 CFM  
Heating Collectors

Collectors/storage - input to air handlers = 2200 CFM

Heating from Storage - Return air to storage - 500 CFM  
lower level

Heating from Storage - Return air to storage = appr. 150-200 CFM  
upper level

Summer Collector Exhaust Fan - appr. 1000 CFM

It was ascertained that the air flow in the mode of solar heating from rock storage was approximately 700 CFM compared to 2200 CFM when charging rock storage. This difference in air velocity is due to the dispersal of return air in the return duct system branch ducts. The duct system to the rock storage from the air handler is more direct than the return air duct system to the rock storage. The return air duct system travels a greater distance and branches in several directions to the collectors and return air grilles. This does not reduce the performance of the system and does not necessitate corrective measures.

It was also noted at the Acceptance Test that the solar system exhaust fan motor was indicating 50% more than the name plate full-load amperes. The manufacturer of the fan motor has verified that the particular model of motor used has the wrong name plate in that the actual full-load amperes is twice that indicated on the name plate.

3. As-Built Drawings

See insert Sheets SE-1, SE-2, SE-3, and SE-4. - Appendix B

4. Operation and Maintenance Manual

- a. Manufacturer's Literature - See insert "Operation Manual for the Helio Thermics Solar Heating System". Appendix C
- b. Operating Mode Table and Control Logic Narrative - See insert "Operating Mode Table". Appendix C

The control computer has sensors located to continuously monitor the temperature of the collector, storage, outdoor air, and the building. The operation of the control computer is based on the temperature setting of the control thermostat in the building. When heat is required in the building, the computer searches out the most economical source to supply the heating needs. When the heating source is determined, the computer sends commands to the air handler and back-up systems to provide the necessary heating. The computer first determines if there is sufficient heat in the collectors to satisfy the demand. If the collector cannot provide the heat, the storage is scanned, and if it can supply the heat, the air is circulated through the storage to supply heat to the building. If the storage cannot supply the heat called for, the computer will activate the heat pump condensing unit to provide auxiliary heat.

When there is more heat in the collector than the building load requires, the computer activates the heat storage mode. In the storage mode the solar air handler fan comes on when the  $\Delta$ temperature is 27° F. and goes off when the  $\Delta$ temperature is 15° F. The collector to building mode is available when the collector to storage differential is satisfied.

See insert "Acceptance Test Plan" for additional control information concerning zone and 2 stage heat bulb operation.



191

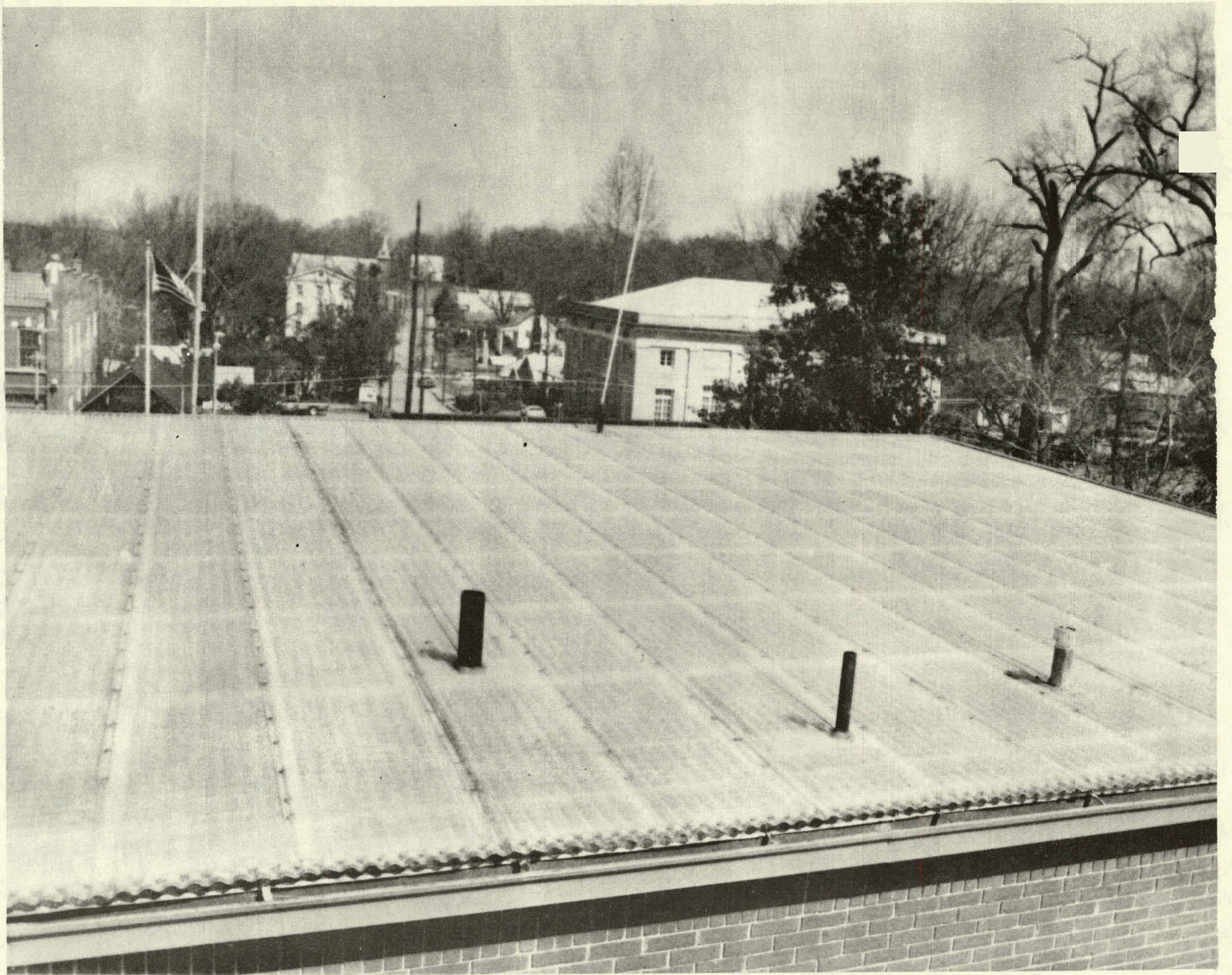

-7-

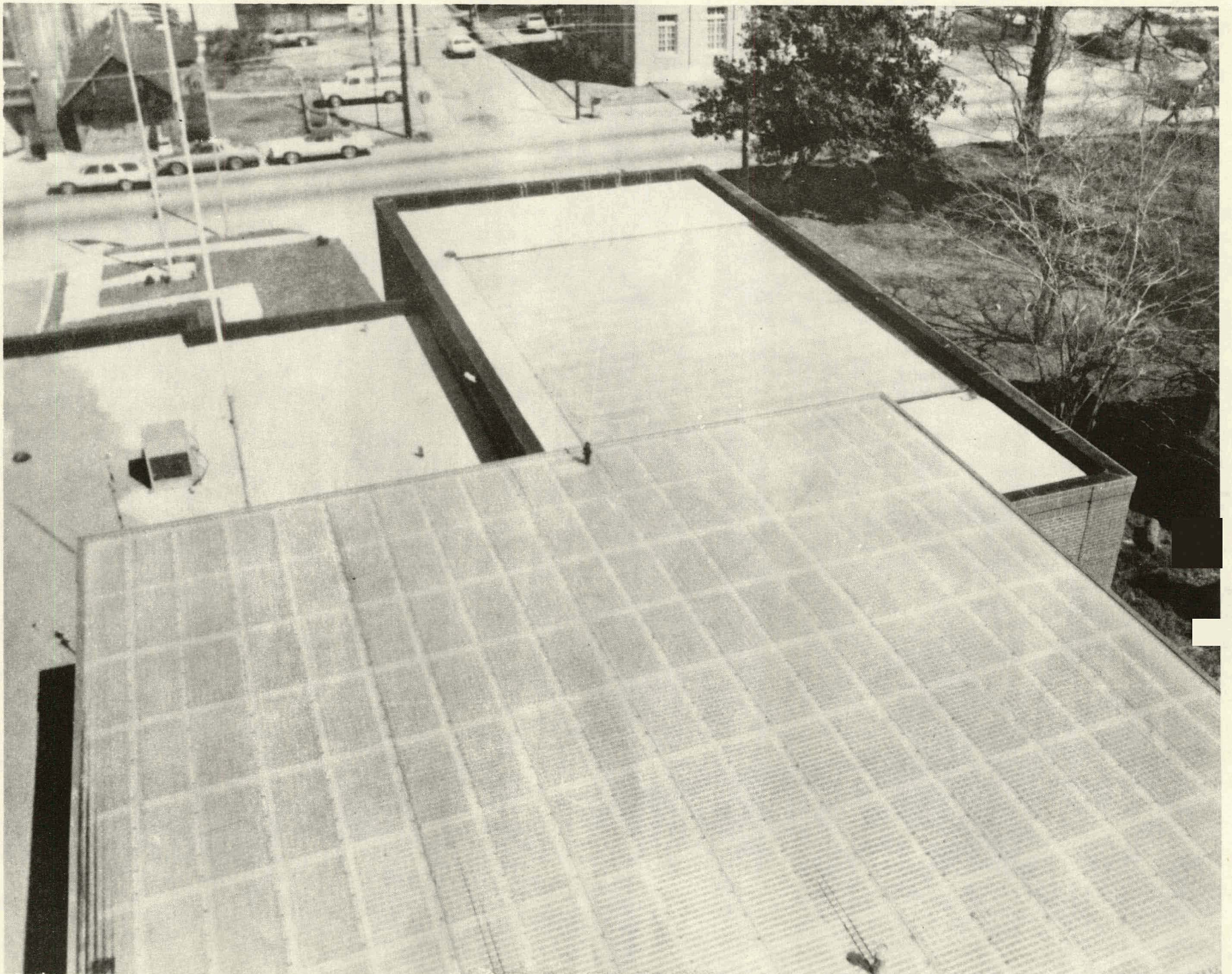

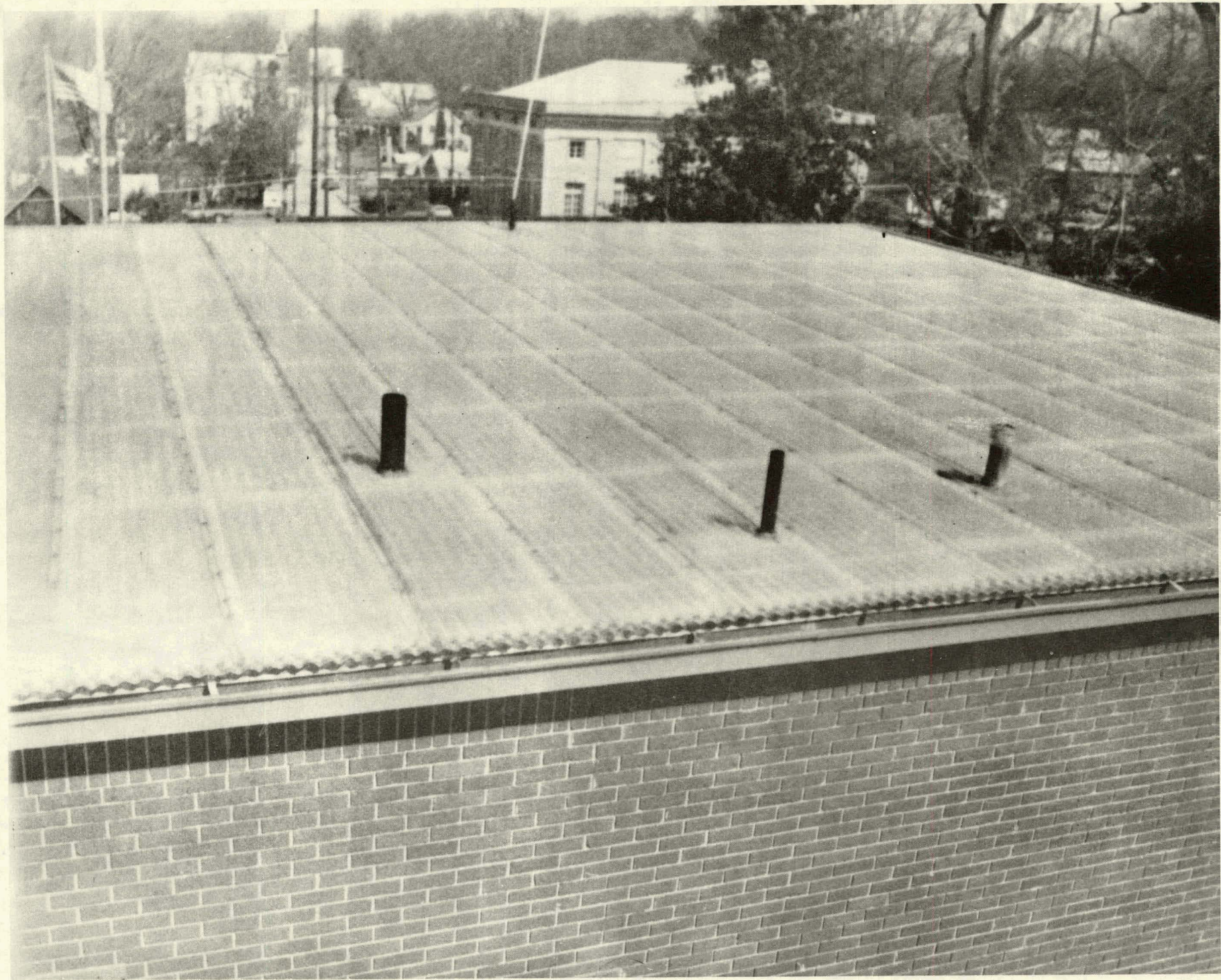

6. Predicted System Performance Data

A. COLLECTOR

COMMERCIAL BRAND NAME\*: HELIO THERMICS MODEL: Job-built unit

TESTED BY AND METHOD: U. S. DEPT. OF AGRICULTURE - RHRU, CLEMSON UNIVERSITY

EST. DELIVERY TIME: 15 DAYS AFTER RECEIPT OF ORDER \*\*

1. TYPE OF COLLECTOR  LIQUID  AIR

a. FLAT PLATE: N/A

b. TUBULAR: N/A EVACUATED: \_\_\_\_\_ NON-EVACUATED \_\_\_\_\_

c. CONCENTRATOR: TRACKING: N/A NON-TRACKING: \_\_\_\_\_

TRACKING MODE: N/A

CONCENTRATION RATIO: N/A :1 TYPE: N/A

d. OTHER: DESCRIBE IN DETAIL JOB BUILT COLLECTOR - TWO LAYERS OF "FILON" CORRUGATED FRP PANELS, CROSS LAPPED. TOP SHEET IS TEDLAR COATED. PANELS INSTALLED ON TOP OF BAR JOISTS. ABSORBER PLATE IS FIBERGLASS DUCTLINER COLORED FLAT BLACK AND INSTALLED ON BOTTOM OF JOISTS.

2. TRANSPARENT COVER

a. NUMBER OF COVERS: 2

b. MATERIALS: OUTER: FRP (TEDLAR COATED) INNER: FRP

c. THICKNESS: OUTER: 1/16 (IN) INNER: 1/16 (IN)

d. SOLAR SPECTRUM TRANSMISSIVITY: OUTER: 76% INNER: 76%

e. WEIGHT: OUTER: .31 LBS/FT<sup>2</sup> INNER: .31 LBS/FT<sup>2</sup>

\*Baseline used for proposal (In the case of required competitive procurement use a typical example for purposes of this section)

\*\* Include an affidavit from collector manufacturer indicating that the quoted price of collectors proposed is valid for a period of 180 days following the closing date of this PON (not applicable for planned competitive procurements).

To = Collector transport media outlet temperature ( $^{\circ}\text{F}$ )

Ti = Collector transport media inlet temperature ( $^{\circ}\text{F}$ )

\*Tc =  $1/2 (To + Ti)$

Ta = Ambient Temperature ( $^{\circ}\text{F}$ )

\*\*I = Solar Insolation on the Collector Plane (BTU/HR- $\text{FT}^2$ )

M = Transport Media mass flowrate (lb/hr.)

Cp = Specific heat of transport media (BTU/LB $^{\circ}\text{F}$ )

\*\*\*Ac = Area of Collector ( $\text{ft}^2$ )

\*The ASHRAE procedure uses  $T_i = T_{\text{inlet}}$  rather than  $T_c = \text{average of inlet and outlet temperatures}$ . Either method is acceptable but state which is being used.

\*\*For tracking collectors this value should be only the beam or direct component for the solar radiation.

\*\*\*Define Ac as gross or net; Ac is gross collector area for ASHRAE 93-77, net aperture area for NBSIR 74-365.

7. MAXIMUM EXPECTED TEMPERATURE UNDER NO FLOW CONDITIONS 200 $^{\circ}\text{F}$

8. DISCUSS PROVISIONS FOR PROTECTING COLLECTOR UNDER NO FLOW CONDITIONS \_\_\_\_\_

During those periods requiring no space heating (summer), heat in the collector will be removed by an exhaust fan which pulls exhaust air over a heat exchanger for pre-heating domestic hot water.

9. COLLECTOR DIMENSIONAL CHARACTERISTICS

a. GROSS AREA 2000 FT $^2$ /PANEL

b. APERTURE AREA 1712 FT $^2$ /PANEL

c. WEIGHTS OF FILLED COLLECTOR Not Applicable LBS/FT $^2$

d. ESTIMATED WEIGHT OF SUPPORT STRUCTURE Not Appl. LBS/FT $^2$

B. SOLAR STORAGE\*

1. TYPE (TANK, ROCK BED, ETC.) Rock Bed
2. MATERIALS
  - a. TYPE: Reinforced Concrete Pit
  - b. FINISHES OR COATINGS: INTERIOR - EXTERIOR -
  - c. COMMERCIAL IDENTIFICATION: -
  - d. INSULATION (TYPE/THICKNESS): 3" foamglas
  - e. R FACTOR: 7.5
3. PHYSICAL DIMENSIONS:
  - a. HEIGHT: -
  - b. WIDTH: 16'-6"
  - c. LENGTH: 21'-3"
  - d. DIAMETER: -
  - e. DEPTH (if buried) 2'-10"
  - f. WATER TABLE DEPTH (if buried) 15'
4. OPERATING TEMPERATURE RANGE: 75<sup>0</sup> to 140 °F
5. OPERATING PRESSURE RANGE: 0 to 0.5" WG PSI
6. BURST PRESSURE OR ASME RATING: Not Applicable PSI

C. HEATING SUBSYSTEM.

1. SOLAR

- a. TYPE: Air Blower FIN COIL, RADIATOR, ETC.
- b. COMMERCIAL UNIT
  1. TYPE: Helio Thermics Model 1900 C
  2. SIZE & BTU RATING (CAPACITY): 3200 SCFM Air
  3. COMMERCIAL IDENTIFICATION: Helio Thermics

2. CONVENTIONAL

- a. TYPE Electric Heat Pumps (Two required) GAS, OIL, ELECTRIC, ETC.

\*If a phase change system, list type, heat capacity, and temperature of phase change.

3. ABSORBER PLATE

a. ABSORPTIVE COATING

1. MATERIALS

a. TYPE: Black color of fiberglass replaces absorptive coating

b. ALLOY: Not Applicable

2. SOLAR SPECTRUM ABSORPTIVITY: .96 %

3. INFRARED EMISSIVITY: .96 %

b. BASE PLATE

1. MATERIALS

a. TYPE: 1" Fiberglass duct liner (black)

b. COMMERCIAL IDENTIFICATION: Certain Teed CSG Ductliner

c. FLUID PASSAGES

1. MATERIALS

a. TYPE: Not Applicable

b. COMMERCIAL IDENTIFICATION: Not Applicable

d. BONDING MATERIALS BETWEEN BASE PLATE AND FLUID PASSAGES

1. TYPE (BRAZED, SOLDERED, ADHESIVE, MECHANICAL, ETC.) Not Appl.

2. COMPOSITION: Not Appl.

3. COMMERCIAL IDENTIFICATION: Not Appl.

4. OTHER Not Appl.

4. INSULATION MATERIAL

a. TYPE: Fiberglass

b. COMPOSITION: Ductliner & batt

c. COMMERCIAL IDENTIFICATION: Certain Teed-CSG and Owens Corning

d. THICKNESS: BACK 13 IN. SIDES 6 IN.

e. R FACTOR: BACK 41 SIDES 19

5. OUTER ENCLOSURE OR SHELL MATERIALS

- a. TYPE: SIDES Concrete Block Building Wall BACK 1½ lb. density fiberglass duct liner
- b. THICKNESS: SIDES 6" batt insulation plus block and brick wall BACK 1"
- c. COMMERCIAL IDENTIFICATION: SIDES None BACK Certain Teed-CSG

6. COMPOSITE COLLECTOR

Performance Data -- Provide test or Performance Analysis Data along with information detailing the conditions under which the data were generated. Active systems require that test results be submitted rating the solar collector in accordance with the NBS "Method of Testing for Rating Solar Collectors Based on Thermal Performance," (Document NBSIR 74-365)<sup>1</sup>, the ASHRAE "Methods of Testing to Determine the Thermal Performance of Solar Collectors" (ASHRAE Standard 93-77)<sup>2</sup>, or through other procedures which will provide similar performance information, as determined by DOE.

PROVIDE A GRAPH OF COLLECTOR EFFICIENCY ( $\eta$ ) VERSUS THE PARAMETER  $\frac{T_c - T_a^*}{I^{**}}$

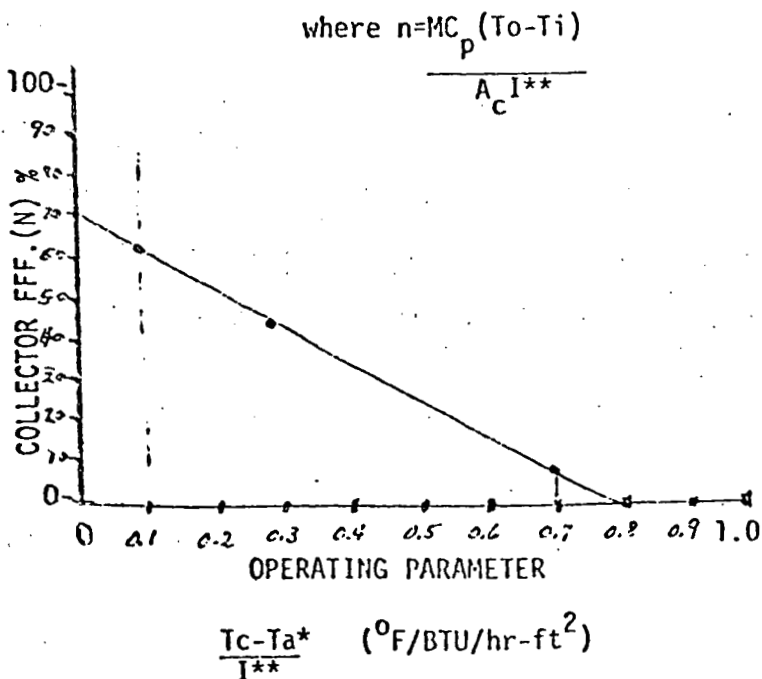

1 Available from DOE, Technical Information Center, P.O. Box 62, Oak Ridge, Tennessee 37830.

2 Available from ASHRAE Inc., 345 East 17th St., New York, N.Y., 10017, \$4.00 Member, \$8.00 Non-Member, plus \$0.35 shipping.

- b. COMMERCIAL UNIT  
 Up stairs unit - 2½ ton heat pump  
 1. SIZE: Downstairs Unit - 5 ton heat pump  
 Westinghouse HS030AB/AJ010C  
 2. COMMERCIAL IDENTIFICATION: Westinghouse HS060AB/AH024C
- c. COEFFICIENT OF PERFORMANCE: IF APPLICABLE, THE COP VERSUS PERTINENT  
 OPERATING CONDITIONS (AMBIENT TEMPERATURE, ETC.) COP at 47<sup>0</sup>F  
ambient and 70<sup>0</sup> EDB: Upstairs - 2.5, Downstairs - 2.7
- 
- d. TOTAL HEATING CAPACITY: at 12<sup>0</sup>F from Heat Pump Cycle - BTU  
46,800 BTU/hr. with backup from electric  
resistance heaters.

D. HOT WATER SUBSYSTEM

1. SOLAR UNIT

- a. TYPE: Helio Thermics
- b. SIZE: 80 gpd
- c. COMMERCIAL IDENTIFICATION: -
- d. HEAT EXCHANGER TYPE:\* Air Fin Copper Coil

2. CONVENTIONAL UNIT

- a. TYPE: Electric (GAS, OIL, ELEC. STEAM, ETC.)
- b. SIZE: 12 kw or 40,956 BTU/hr. VOL. OR BTU
- c. COMMERCIAL IDENTIFICATION: Jackson Model No. GRE-100-T
- d. CODE & SAFETY STD. CERTIFIED UNDER: Underwriters' Laboratory

E. COOLING SUBSYSTEM

1. SOLAR

- a. TYPE: Not Applicable
- b. SIZE: Not Applicable TONS

\*Proposers are referred to the IPC for measures necessary to isolate potable and non-potable water systems.

c. COMMERCIAL UNIT IDENTIFICATION: Not Applicable

d. COP VS. CHILLED AND CONDENSING WATER TEMPERATURE TABLES:  
Not Applicable

2. CONVENTIONAL

a. TYPE: RECIP.

b. COMMERCIAL UNIT

1. TYPE: Split System Heat Pump

2. SIZE: Upstairs - 2½ ton    Downstairs - 5 ton

3. IDENTIFICATION: Upstairs - Westinghouse HS030AB/AJ010C  
Downstairs - Westinghouse HS 060AB/AHQ24C

4. COP VS. TEMPERATURE TABLE: at 95<sup>0</sup>F ODB, 80<sup>0</sup> EDB/67<sup>0</sup>EWB:  
Upstairs - 2.5  
Downstairs - 2.5

F. TRANSPORT BETWEEN SUBSYSTEMS

1. DUCT PIPING DETAILS		COLLECTOR TO STORAGE	STORAGE TO LOAD
a.	INNER DIAMETER: <u>Air Duct</u>	<u>22 in</u>	<u>22 in</u>
b.	OUTER DIAMETER: _____	<u>- in</u>	<u>- in</u>
c.	LENGTH OF RUN TOTAL: _____	<u>110 ft</u>	<u>120 ft</u>
d.	MATERIALS: <u>Galvanized Steel Duct</u>	<u>Galvanized Steel Duct</u>	
2. DUCT PIPING INSULATION			
a.	TYPE: <u>Fiberglass</u>	<u>Fiberglass</u>	
b.	THICKNESS: _____	<u>2 in</u>	<u>2 in</u>
c.	'U' FACTOR: _____	<u>8.0</u>	<u>8.0</u>
3. TRANSPORT MEDIA			
a.	TYPE: _____	<u>Air</u>	<u>Air</u>
b. ADDITIVES			
1.	COMMERCIAL IDENTIFICATION: _____	<u>None</u>	<u>None</u>
2.	TYPE: _____	<u>None</u>	<u>None</u>
c. QUANTITIES OF FLUID IN SUBSYSTEM			
1.	FLUID: _____	<u>None</u>	<u>None</u> %
2.	ADDITIVE: _____	<u>None</u>	<u>None</u> %

	COLLECTOR TO STORAGE	STORAGE TO LOAD
	*NOT APPLICABLE	
3.	pH: _____ None	None
4.	ION CONTENT: _____ None	None
5.	MINERAL CONTENT: _____ None	None
6.	DURABILITY (SERVICE LIFE): None MONTHS	- None MONTHS
d.	SPECIFIC HEAT: _____ .240	.240
e.	FLOW RATE (LIQUID): _____ None - GPM	None GPM
	FLOW RATE (AIR): _____ 3200 SFCM	3200 SFCM GPM
f.	SPECIFY PRESSURE DROP BETWEEN COMPONENTS: _____ .15" WG PSI	.25" WG --PSI-
4.	HEAT EXCHANGERS *NOT APPLICABLE	
a.	TYPE (CROSS OR COUNTERFLOW): _____ None	None
b.	FLOWRATE: _____ None GPM	None GPM
c.	OVERALL UA FACTOR: _____ None BTU/OF	None BTU/OF

5. PROVIDE FLOW DIAGRAM FOR PROPOSED SOLAR ENERGY SYSTEM, GIVING SUBSYSTEM COMPONENTS LOCATION AND IDENTIFICATION AND FLOW DIRECTIONS.

G. CONTROL SYSTEM (ATTACHED SHEET S-E 4)

SHOW FOR EACH MODE OF OPERATION A DESCRIPTION OF COMPONENTS AND VERBAL DESCRIPTION OF CONTROL SYSTEM; INTEGRATED SOLAR AND CONVENTIONAL SYSTEM(S) OPERATIONS.

PROVIDE A SCHEMATIC OF CONTROL SYSTEM (MAY BE INTEGRATED WITH F. 5.

ELECTRICAL POWER

1. OPERATING REQUIREMENTS

a. THE ELECTRICAL ENERGY REQUIRED TO DRIVE THE SOLAR COLLECTION PORTION OF THE SYSTEM IS 1.75 kw

- 1. PUMPS 0.25 kw FUNCTION Hot Water Circulation
- 2. FANS 1.49 kw FUNCTION Collector Air Circulation
- 3. CONTROLS .01 kw FUNCTION Temperature Sensing & Damper positioning
- 4. OTHER \_\_\_\_\_ kw FUNCTION \_\_\_\_\_

b. THE ELECTRICAL ENERGY REQUIRED TO DRIVE THE STORAGE TO LOAD PORTION OF THE SYSTEM IS 1.5 kw

- 1. PUMPS \_\_\_\_\_ kw FUNCTION \_\_\_\_\_
- 2. FANS 1.49 kw FUNCTION Storage Air Circulation
- 3. CONTROLS 0.01 kw FUNCTION Temperature Sensing & Damper Positioning
- 4. OTHER \_\_\_\_\_ kw FUNCTION \_\_\_\_\_

2. DESIGN LOAD DATA:

INCLUDE LOAD DUE TO VENTILATION REQUIREMENTS

BUILDING LOAD TABLE

MONTH	HEATING (BTU)	HOT WATER (BTU)	COOLING (BTU)
January	$12.5 \times 10^6$	$2.0 \times 10^6$	-
February	$9.5 \times 10^6$	$1.7 \times 10^6$	-
March	$8.3 \times 10^6$	$1.8 \times 10^6$	-
April	$4.2 \times 10^6$	$1.6 \times 10^6$	$2.9 \times 10^6$
May	$1.2 \times 10^6$	$1.5 \times 10^6$	$6.0 \times 10^6$
June	-	$1.4 \times 10^6$	$11.7 \times 10^6$
July	-	$1.3 \times 10^6$	$15.0 \times 10^6$
August	-	$1.2 \times 10^6$	$12.1 \times 10^6$
September	-	$1.3 \times 10^6$	$8.7 \times 10^6$
October	$3.0 \times 10^6$	$1.5 \times 10^6$	$3.0 \times 10^6$
November	$8.9 \times 10^6$	$1.7 \times 10^6$	-
December	$11.9 \times 10^6$	$2.0 \times 10^6$	-
YEARLY TOTAL	$59.5 \times 10^6$	$19.0 \times 10^6$	$59.4 \times 10^6$
DESIGN PEAK (BTUH)	47,880	33,300	81,000

SOLAR SYSTEM ARRAY PERFORMANCE

COLLECTOR TYPE: Job Built Air Type

LOCATION: Abbeville, S. C.

ARRAY AREA: 2000 FT<sup>2</sup>; LATITUDE: 34°-11' °; TILT ANGLE FROM HORIZONTAL: 0 °; AZIMUTH: Not Appl.

••West  
0•Due South  
••East

LINE	DESCRIPTION	UNITS	MONTH											
			J	F	M	A	M	J	J	A	S	O	N	D
(1)	Number of days		31	28	31	30	31	30	31	31	30	31	30	31
(2)	Average Temp. - (Tamb) <sup>*</sup>	°F	36	37	41	50	59	66	69	68	63	52	40	35
(3)	Max Average Temp (Tmax) <sup>*</sup>	°F	54	57	63	72	81	87	88	88	83	74	62	53
(4)	Average Ambient (Tall/2 (2) + (3))	°F	45	47	52	61	70	77	79	78	73	63	51	44
(5)	Clearness Factor	-	0.93	0.93	0.93	0.93	0.93	0.93	0.93	0.93	0.93	0.93	0.93	0.93
(6)	Average Collector Temp - (Tc) = 1/2(Tin+Tout)	°F	25	27	29	33	38	47	52	50	48	36	30	26
(7)	Collector Efficiency	-	46.6	46.6	46.6	46.6	46.6	46.6	46.6	46.6	46.6	46.6	49.0	46.9
(8)	Clear Air Daily Insolation on Tilted Collector Surface	BTU/ft <sup>2</sup>	26,257	32,956	41,151	54,390	61,163	60,480	64,543	54,901	44,160	35,945	25,260	22,320
(9)	Percentage Sunshine <sup>*</sup>		53	57	62	58	69	68	63	65	64	68	64	51
(10)	Monthly Probable Insolation	BTU/ft <sup>2</sup>	3,916	13,785	27,234	36,785	42,202	41,126	38,142	35,626	28,262	24,347	16,166	11,320
(11)	Collected Energy (Qc)	Million BTU	11.1	11.5	10.4	6.0	2.8	1.5	1.4	1.3	1.4	4.7	10.9	9.1
(12)	Q Loss (Piping & Losses)	Million BTU	.3	.3	.3	.2	.1	.1	.1	.1	.1	.2	.3	.3
(13)	Q Usable	Million BTU	10.8	11.2	10.1	5.8	2.7	1.4	1.3	1.2	1.3	4.5	10.6	8.8
(14)	Total Load Bld (Solar Conditioned)	Million BTU	14.5	11.2	10.1	5.8	2.7	1.4	1.3	1.2	1.3	4.5	10.6	13.9
(15)	Auxiliary Energy Required	Million BTU	3.7	-	-	-	-	-	-	-	-	-	-	5.1
(16)	% Solar Contribution		74.4	100	100	100	100	100	100	100	100	100	100	63.3
(17)	Time of Collector Operation	Hours	217	252	279	270	279	270	279	279	270	279	210	217
(18)	Electric Power for Collection Subsystem	KWH	304. <sup>8</sup>	264. <sup>6</sup>	195. <sup>4</sup>	95. <sup>2</sup>	7. <sup>1</sup>	7. <sup>1</sup>	7. <sup>1</sup>	7. <sup>1</sup>	95. <sup>2</sup>	195. <sup>4</sup>	220. <sup>6</sup>	304. <sup>8</sup>
(19)	Electric Power for Storage to Load Subsystem	KWH	76. <sup>2</sup>	113. <sup>3</sup>	167. <sup>4</sup>	121. <sup>3</sup>	-	-	-	-	121. <sup>3</sup>	167. <sup>4</sup>	95. <sup>3</sup>	76. <sup>2</sup>
(20)	Total Solar System Electric Power	KWH	380	377	362	216	7	7	7	7	216	362	315	380

Source of Data to be Specified: U. S. Dept. of Commerce Climatic Atlas of the U.S.

## 7. Major Problems Encountered

No Major problems were encountered in the implementation of the solar system. Excessive condensation in the Zone 1 heat pump air handler caused a leakage problem, but it was determined that the excess condensation was a result of a problem in the air handler and not related to the solar system operation with the air handler. Baffles were installed in the air handler to redistribute the air flow over the condensing coil and this corrected the excess condensation.

## 8. Lessons Learned and Recommendations

The major lesson learned in the design and installation of the solar system is the difficulty encountered in implementing the system into a building not originally designed for a solar application. Some provisions were made in the building for a possible solar system application, but difficulty was encountered in the fact that the building was designed and under construction when the grant for the solar system was approved. This resulted in the collectors being located on two different roof areas. Having the collectors on one roof area and having the system originally designed into the building would have resulted in simpler and shorter runs of solar ductwork. If the system had been originally designed in the building, the capacity of the conventional system could have been reduced resulting in a reduction in the total building cost.

9. Verification Statements

The following statements are verified by the Project Architect and Mechanical Engineer:

- a. The As-Built Drawings accurately show the solar heating system configuration as of completion of construction and acceptance by the Architect and Engineer.
- b. The Acceptance Test Plan has been implemented according to the method as directed by D.O.E. and indicated in the Acceptance Test Plan.
- c. The solar heating system conforms to all provisions set forth in Interim Performance Criteria (NBSIR 76-1187) that apply to this project.

Signed:

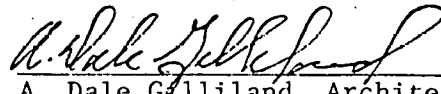

A. Dale Gilliland, Architect  
S.C. Reg. No. 1285

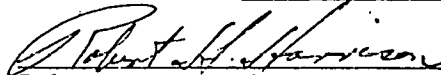

Robert H. Harrison  
Professional Engineer

APPENDIX A

ACCEPTANCE TEST PLAN

FOR

MUNICIPAL BUILDING COMPLEX

SOLAR SYSTEM

ABBEVILLE, SOUTH CAROLINA

---

CITY OF ABBEVILLE, SOUTH CAROLINA

---

U. S. DEPARTMENT OF ENERGY  
EM-78-F01-5202  
WASHINGTON, D. C. 20545

---

HELIO THERMICS, INC.  
SOLAR MANUFACTURING & DESIGN  
GREENVILLE, SOUTH CAROLINA

---

GILLILAND-BELL ASSOCIATES, INC.  
ARCHITECTS-ENGINEERS-PLANNERS  
SOLAR DESIGN  
GREENWOOD, SOUTH CAROLINA

JOB NO.  
7641-A

D.O.E. NO.  
EM-78-F01-5202

DATE  
2-14-79

ABBEVILLE MUNICIPAL BUILDING

SOLAR HOT WATER SYSTEM

ACCEPTANCE TEST PLAN

I. Locate and Identify the following system components:

- A. Manual outside exhaust damper.
- B. Blower and blower motor. (tubeaxial type)
- C. Blower motor electrical cord.
- D. Differential controller with collector, tank, and anti-freeze protect sensor. This controller activates pump to provide water-flow when collector to tank differential is met or when anti-freeze sensor monitors ambient air of heat exchange coil below 35°F.
- E. Circulating pump - 1/20 Horsepower.
- F. Heat exchange coil. (Air to Water)
- G. Preheat storage tank.
- H. Service shut-off & by-pass valves. (manual type)
  - a. Preheat tank inlet valve.
  - b. Preheat tank outlet valve.
  - c. Preheat tank bypass valve.

II. Acceptance Test Invitation:

Before testing begins do the following:

- A. Open preheat tank inlet valve. (a)
- B. Open preheat tank outlet valve. (b)
- C. Close preheat tank bypass valve. (c)
- D. Open manual outside exhaust damper. (A)
- E. Plug blower motor electrical cord (C) into 110 V.A.C. single phase receptacle.

III. Acceptance Test:

- A. Verify blower motor is operating if collector air temperature is 130° F or above.
- B. Verify blower motor is shut down if collector air temperature is 115° F or below.
- C. Verify circulating pump is operating if collector to tank differential is above 27°F.
- D. Verify circulating pump is not operating if collector to tank differential is less than 15°F, and exchange coil ambient above 35°F.
- E. If pump is operating and blower extracting hot air, measure Delta temperature across heat exchange coil water inlet-outlet.

- F. If circulating pump is shut down short across collector sensor terminals to activate pump for test.
- G. This completes acceptance test, return all valves, dampers, controls to pre test positions.

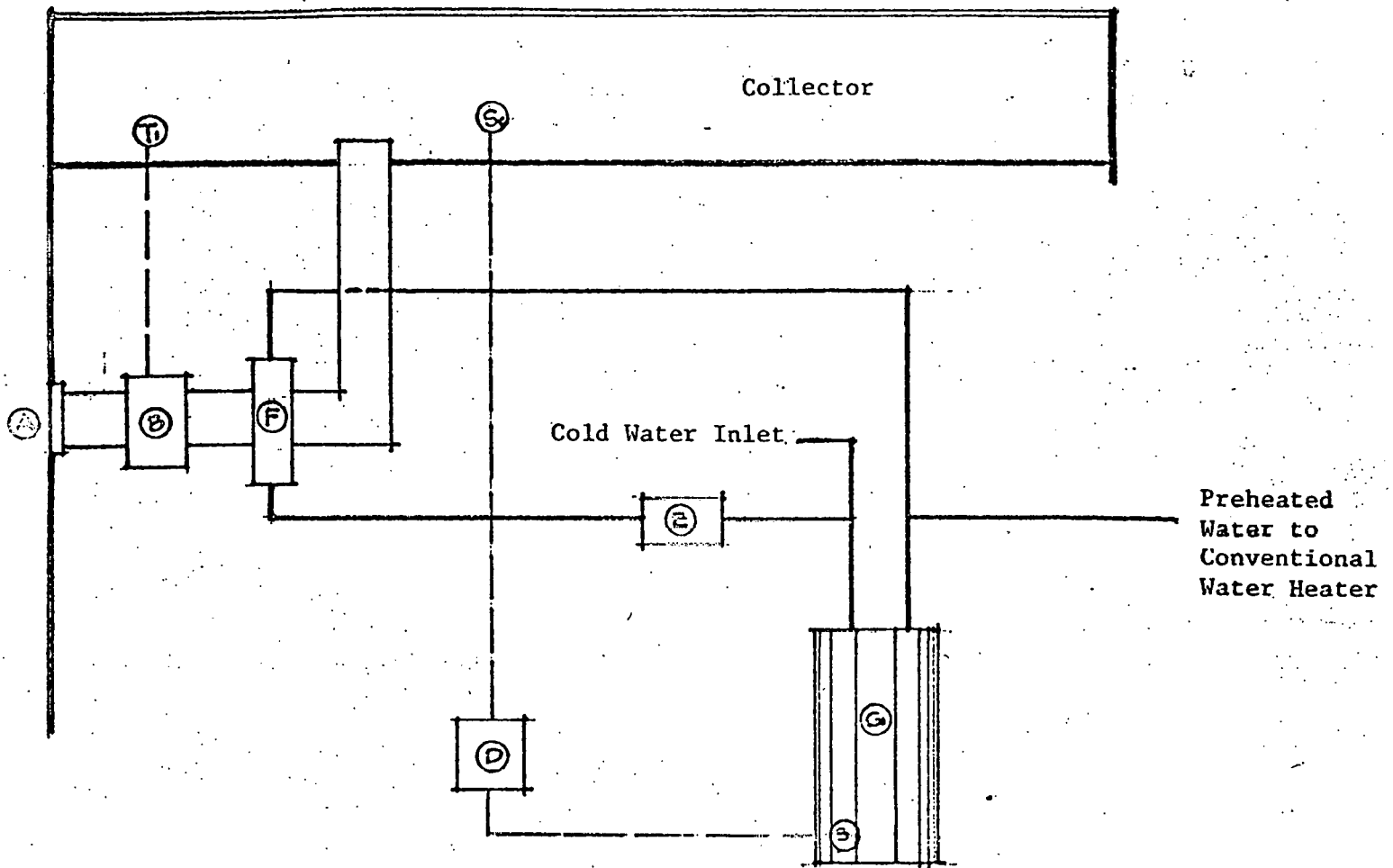

SOLAR HOT WATER SYSTEM DIAGRAM

1. Blower moves air from collector to outside when T<sub>1</sub> is above 130° F and shuts down when T<sub>1</sub> is below 115° F.
2. Pump moves water when collector sensor is 27° hotter than tank sensor; shuts down flow when 15° F hotter than tank.
3. Both pump and blower must be on to heat water.

## SYSTEM CHECK-OUT

### 1. Locate and identify the following components:

- A. Solar air handler
- B. Solar collector
- C. Cool air intake (outdoor air)
- D. Zone 2 return air (solar)
- E. Zone 1 return air (solar)
- F. Supply air zone 2
- G. Supply air zone 1
- H. Thermal storage unit
- I. Zone 2 thermostat
- J. Zone 1 thermostat
- K. Zone 1 mode display panel
- L. Zone 2 heat pump air handler
- M. Zone 1 heat pump air handler
- N. Zone 2 heat pump condensing unit
- O. Zone 1 heat pump condensing unit
- P. Zone 2 return air storage bypass damper pair
- Q. Zone 1 return air storage bypass damper pair

### 2. Read operation narrative to familiarize with system operation.

### 3. Set T-1 thermostat while monitoring Zone 1 mode display panel to set mode 8 back-up cooling.

- Check:
- A. Zone 1 return air storage bypass dampers operate to allow zone 1 return air to bypass storage by entering at point Q.
  - B. Heat pump air handler on
  - C. Heat pump condensing unit on cooling cycle

### 4. Set T-1 thermostat while monitoring zone 1 mode display panel to set mode 7 - storage to building cool.

- Check:
- A. Zone 1 return air storage bypass dampers operate to allow zone 1 return air to flow through storage.
  - B. Heat pump air handler on
  - C. Heat pump condensing unit off

### 5. Set T-1 thermostat while monitoring zone 1 mode display panel to set mode 5 - outside to building.

- Check:
- A. Zone one return air storage bypass dampers operate to allow zone 1 return air to flow outside.
  - B. Heat pump air handler on
  - C. Heat pump air condensing unit off

System check out continuation:

6. Set T-1 thermostat while monitoring zone 1 mode display panel to set mode 4 - back-up heat.

Check: A. Zone 1 return air storage bypass dampers operate to allow zone 1 return air to bypass storage by entering at point Q.  
B. Heat pump air handler on  
C. Heat pump condensing unit on heating cycle

7. Set T-1 thermostat while monitoring zone 1 mode display panel to set mode 3 - storage to building heat.

Check: A. Zone 1 return air storage bypass dampers operate to allow zone 1 return air to flow through storage.  
B. Heat pump air handler on  
C. Heat pump condensing unit off

8. Set T-1 thermostat while monitoring zone 1 mode display panel to set mode 1 - collector to building

Check: A. Zone 1 return air storage bypass dampers operate to allow zone 1 return air to flow to collector  
B. Heat pump air handler on  
C. Heat pump condensing unit off

9. Set T-1 thermostat while monitoring zone 1 mode display panel to set mode 2 - Collector to storage.

Check: A. No air coming from supply to building ducts.  
B. Heat pump air handler off, solar air handler on.  
C. Heat pump condensing unit off.

10. Set T-1 thermostat while monitoring zone 1 mode display panel to set mode 6 - Outside to storage.

Check: A. No air coming from supply to building ducts.  
B. Heat pump air handler off, solar air handler on.  
C. Heat pump condensing unit off.

NOTE: Whenever solar heat or natural cooling is available to zone 1, it is also available to zone 2.

Whenever zone 1 is on back-up heat or cool, zone 2 is also on back-up heat/cool if required.

SEQUENCE: COOLING

Zone 1 calls for Cooling (main zone)

Stage 1 cooling bulb is closed.

1. Heat pump air handler fan is turned on for Zone 1.
2. Solar air handler receives signal and chooses mode, dampers modulate air flow to heat pump - air handler (solar fan off) Zone 1.

Stage 2 cooling bulb is closed.

1. Zone 1 heat pump air handler stays ON (stage one bulb still closed).
2. Solar air handler receives signal for back up cooling, chooses that mode, and activates heat pump compressor on cooling cycle. (electronically) (solar fan off).

Zone 2 calls for cooling while zone 1 is cooling from solar.

Zone 2 stage 1 cool bulb is activated.

1. Zone 2 heat pump air handler is turned on.
2. Zone 1 is already on natural cooling to building mode and cool air is available to zone 2 heat pump air handler for zone 2 cooling.

Zone 2 stage 2 bulb is activated.

1. Zone 2 heat pump air handler remains on (stage one bulb still on)
2. Stage 2 bulb activates heat pump compressor to provide back-up cooling

Zone 2 calls for cooling while Zone 1 is on back-up cool.

1. Zone 2 heat pump air handler turns on upon stage 1 bulb activation.
2. Upon stage 2 bulb activation heat pump compressor turns on supplying back-up cooling to Zone 2.

SEQUENCE: HEATING

Zone 1 calls for heat (main zone).

Stage 1 heat bulb is closed.

1. Heat pump air handler fan is turned on for Zone 1
2. Solar air handler receives signal and chooses mode, dampers modulate air flow from collector or storage (depending upon mode) to heat pump-air handler (solar fan off) Zone 1.

Stage 2 heat bulb is closed.

1. Zone 1 heat pump air handler stays ON (stage one bulb still closed).
2. Solar air handler receives signal for back up heat, chooses that mode, and activates heat pump compressor on heating cycle (electronically) (Solar Fan Off).

Zone 2 calls for heat while zone 1 is heating from solar.

Zone 2 stage 1 heat bulb is activated:

1. Zone 2 heat pump air handler is turned on
2. Zone 1 is already on solar to building mode and solar heated air is available to zone 2 heat pump air handler for zone 2 heating.

Zone 2 stage 2 bulb is activated.

1. Zone 2 heat pump air handler remains on (stage one bulb still on)
2. Stage 2 bulb activates heat pump compressor to provide back-up heat.

Zone 2 calls for heat while Zone is on back-up heat.

1. Zone 2 heat pump air handler turns on upon stage 1 bulb activation.
2. Upon stage 2 bulb activation heat pump compressor turns on supplying back up heat to Zone 2

## SYSTEM ACTIVATION

1. Check to make sure air handler selector switch is in OFF position, and that all preceding instructions have been complied with.
2. Connect AC volt meter to the power supply circuit (wire coming out of box in wall).
3. After making certain that air handler is NOT connected to POWER SUPPLY circuit, momentarily turn air handler breaker to ON to verify proper supply voltage.
4. Turn air handler breaker OFF.
5. Make power supply connection from electrical box on wall to air handler makeup box. Make sure local codes are complied with.
6. Check all wiring to make sure it is properly installed - that there are no loose connections or wires touching that could be shorted.
7. Turn air handler breaker to ON position.
8. Turn backup heat breaker to ON position.
9. Turn backup cooling breaker to ON position.
10. Turn selector switch on air handler to Emergency backup position to verify operation of backup source and air handler.
11. Turn selector switch on air handler to ON position, and storage switch to Heat position (for winter operation) or Cool position (for non-heating season.)
12. Set T-1 thermostat to desired zone 1 temperature.
13. Set T-2 thermostat to same temperature as T-1 to provide proper interlock.
14. Set both subbase switches to either heat, or cool. In winter, BOTH switches should be set to heat position, in summer both should be set to cool position.

SYSTEM COMPONENT DIAGRAM

GRAVITY DAMPER FOR SUMMER EXHAUST

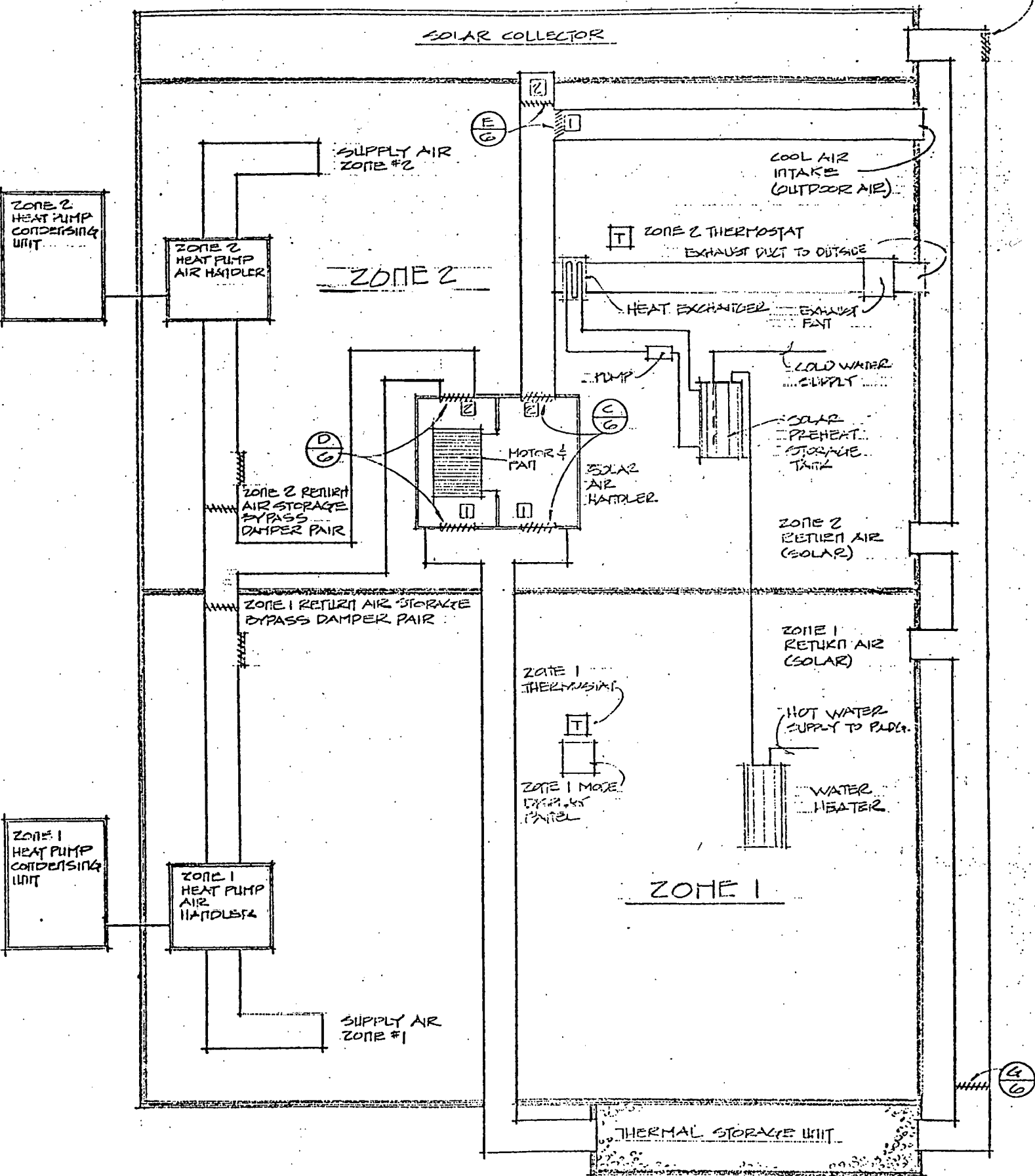

APPENDIX B

SOLAR HEATING & HOT WATER SYSTEM

AS-BUILT PLANS & DIAGRAMS

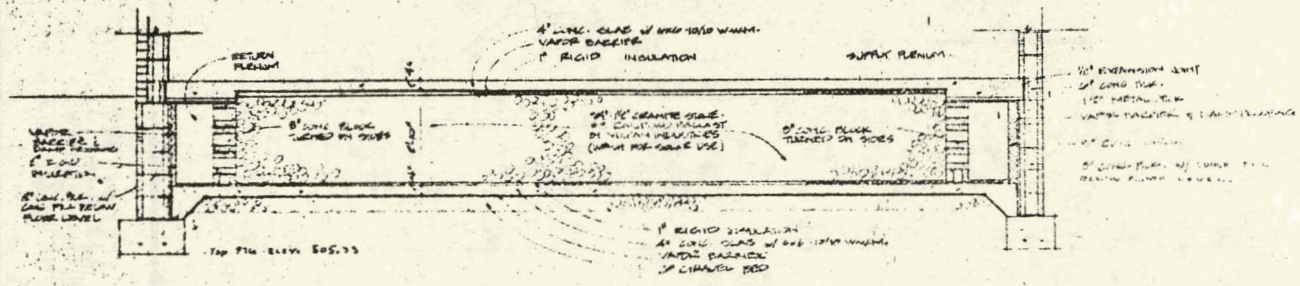

1 SECTION THRU ROCK STORAGE VAULT  
 1/8" = 1'-0"

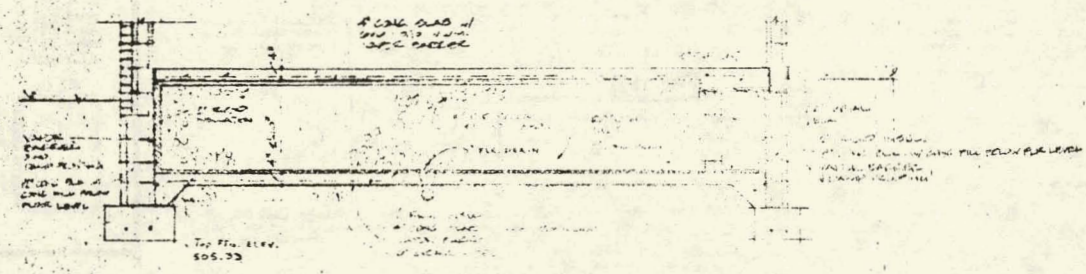

2 SECTION THRU ROCK STORAGE VAULT  
 1/8" = 1'-0"

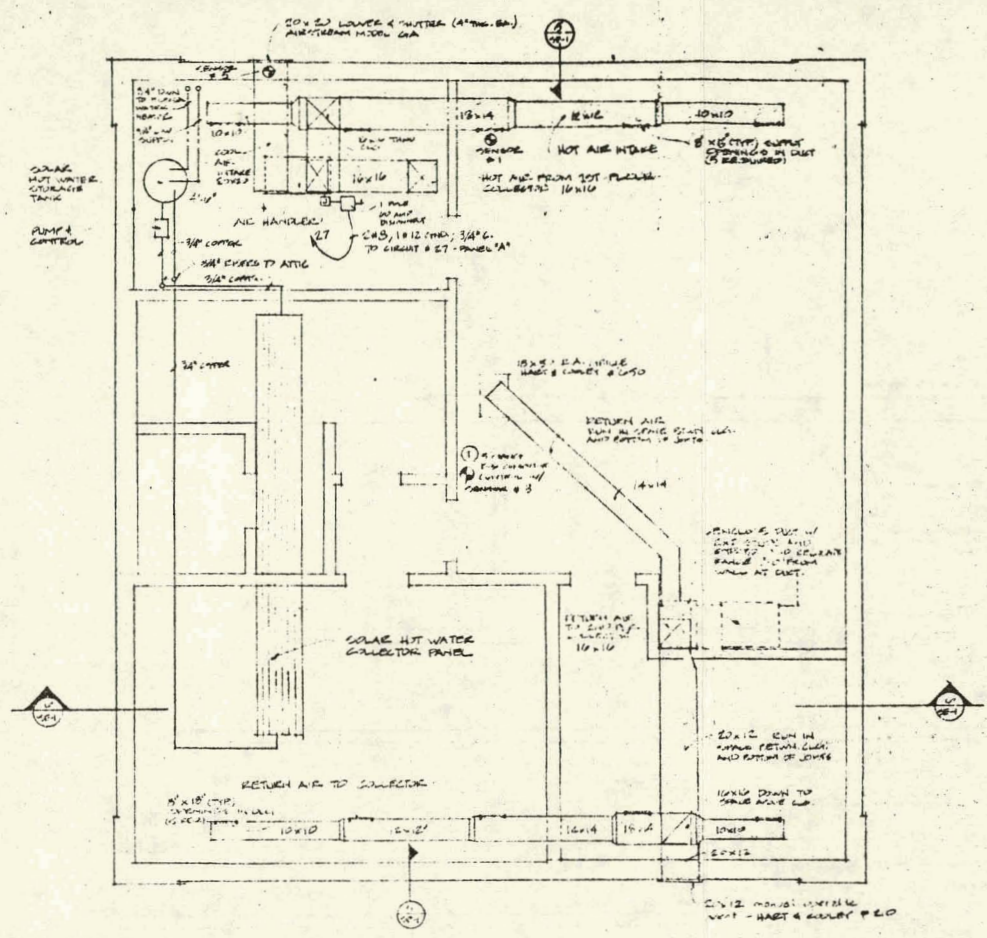

4 SECOND FLOOR SOLAR, MECHANICAL, ELECTRICAL, AND PLUMBING PLAN  
 1/4" = 1'-0"

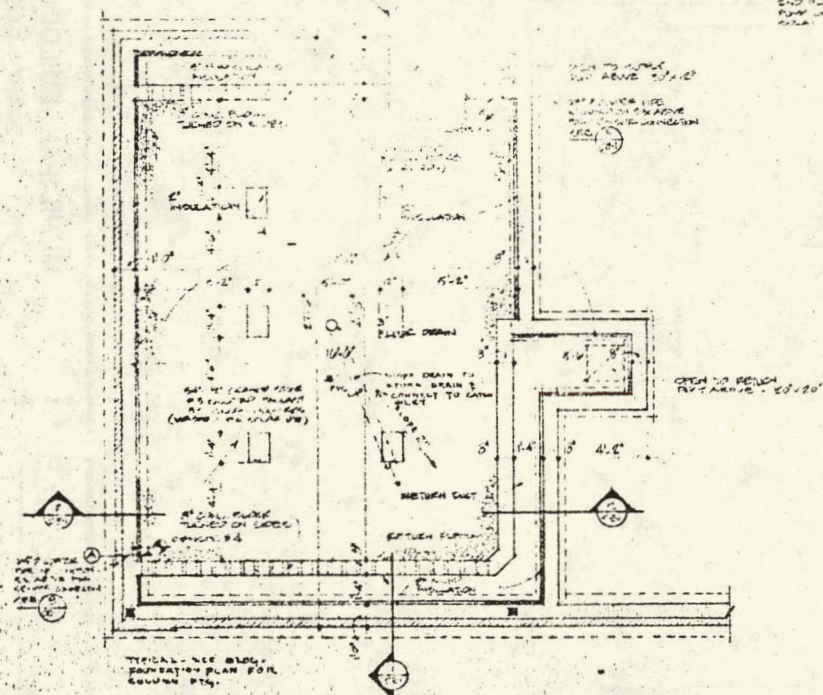

5 ROCK STORAGE VAULT PLAN  
 1/4" = 1'-0"

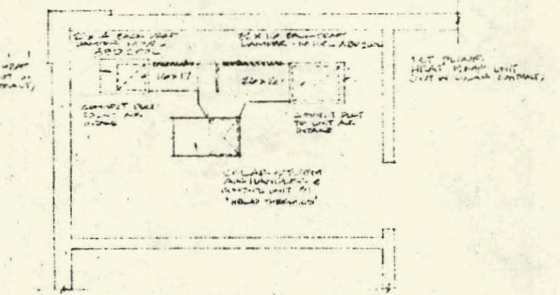

7 PLAN - SOLAR EQUIP. CONNECTION TO BUILDING MECH. EQUIPMENT  
 1/4" = 1'-0"

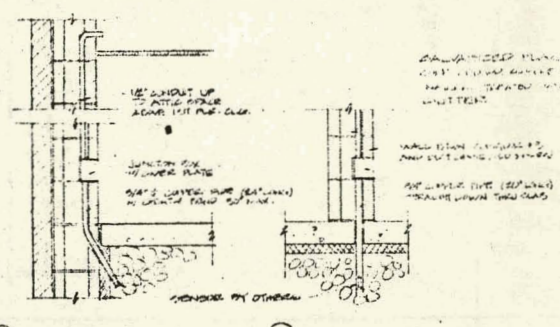

8 SECTIONS & SENSOR LOCATIONS  
 1/4" = 1'-0"

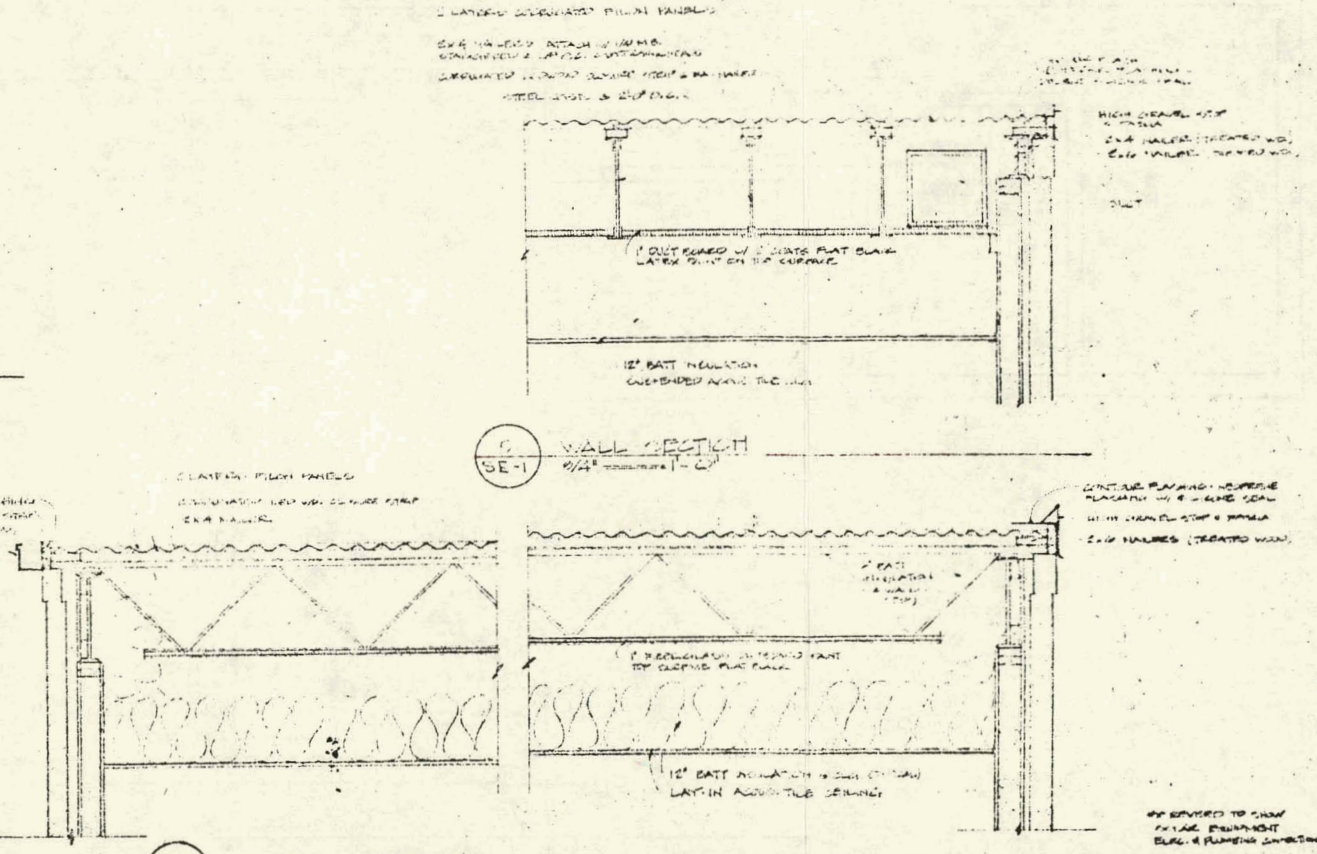

6 CROSS SECTION  
 1/4" = 1'-0"

GILLILAND-BELL ASSOCIATES, INC.  
 ARCHITECTS-ENGINEERS-PLANNERS-GREENWOOD, S.C.  
 A. DALE GILLILAND, ARCHITECT | CHARLES A. BELL, ENGINEER

MUNICIPAL BUILDING COMPLEX  
 SOLAR ENERGY SYSTEM  
 City of Abbeville  
 South Carolina  
 Abbeville

SOLAR ENERGY SYSTEM  
 ROCK STORAGE VAULT PLAN  
 END FLOOR SOLAR MECH. PLAN

COMM. 7-4-1-A	SHEET NO.
DATE 10-24-79	11
REVISED 11/27/79	OF 11
11/27/79	TOTAL

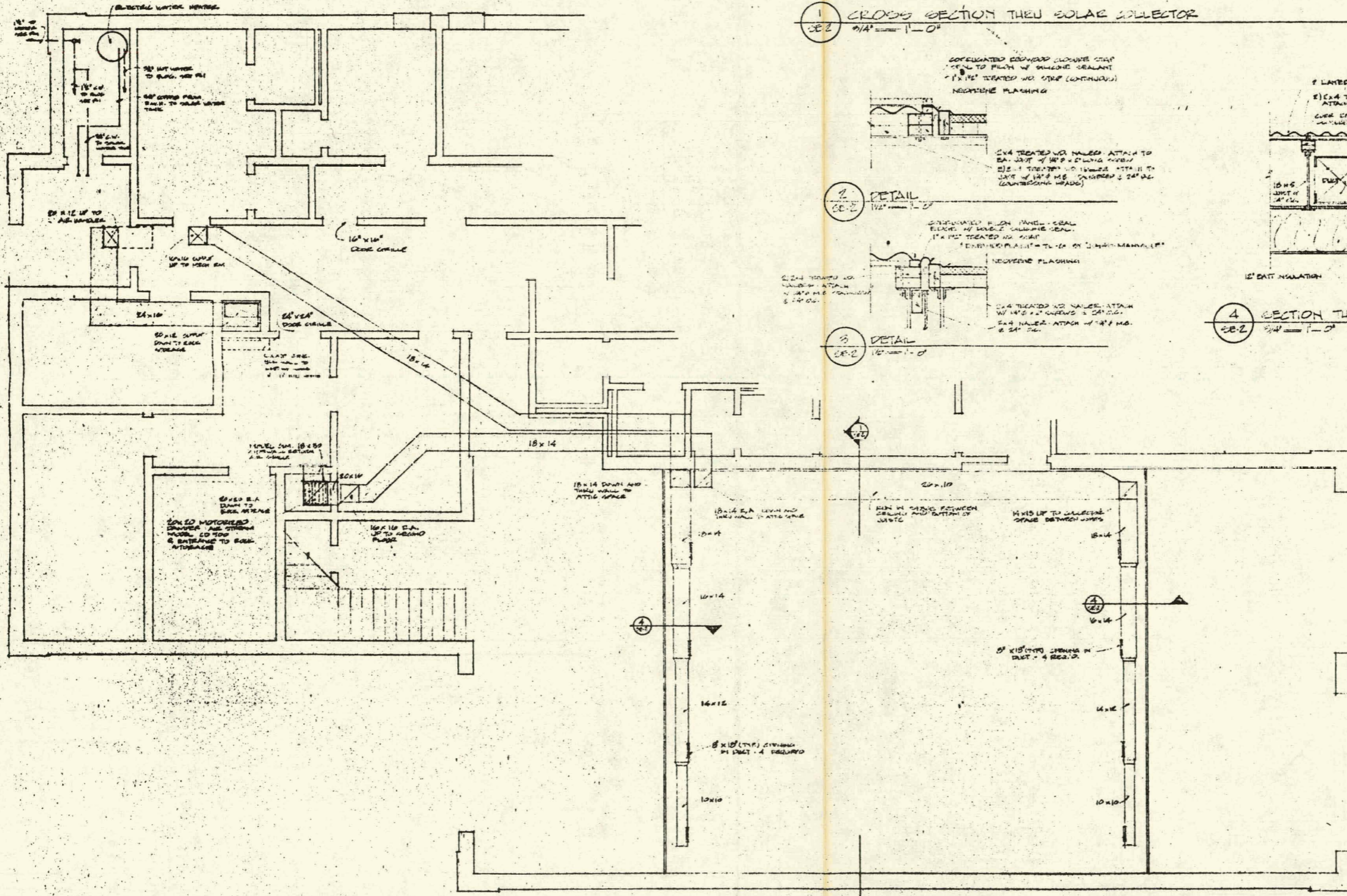

5 FIRST FLOOR SOLAR MECHANICAL PLAN  
1/4" = 1'-0"

1 CROSS SECTION THRU SOLAR COLLECTOR  
1/4" = 1'-0"

2 DETAIL  
1/2" = 1'-0"

3 DETAIL  
1/2" = 1'-0"

4 SECTION THRU COLLECTOR SIDE WALL  
1/4" = 1'-0"

GILLILAND-BELL ASSOCIATES, INC.  
ARCHITECTS-ENGINEERS-PLANNERS-GREENWOOD, S.C.  
A. DALE GILLILAND, ARCHITECT | CHARLES A. BELL, ENGINEER

MUNICIPAL BUILDING COMPLEX  
SOLAR ENERGY SYSTEMS  
City of Abbeville  
Abbeville South Carolina

SOLAR ENERGY SYSTEM  
FIRST FLOOR SOLAR MECHANICAL PLAN  
SECTIONS AND DETAILS

COMPL. NO. 441-A	SHEET NO. 33
DATE: 2/25/77	OF 33
REVISED: 5/14/75	TOTAL

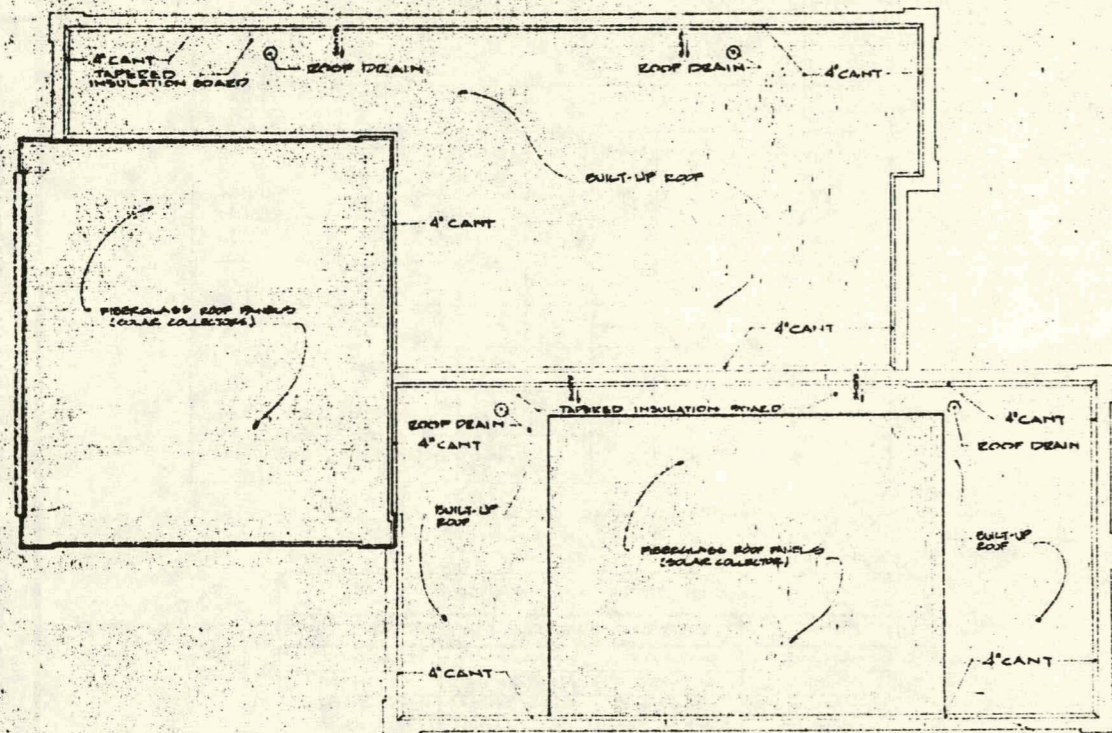

ROOF PLAN  
1/8" = 1'-0"

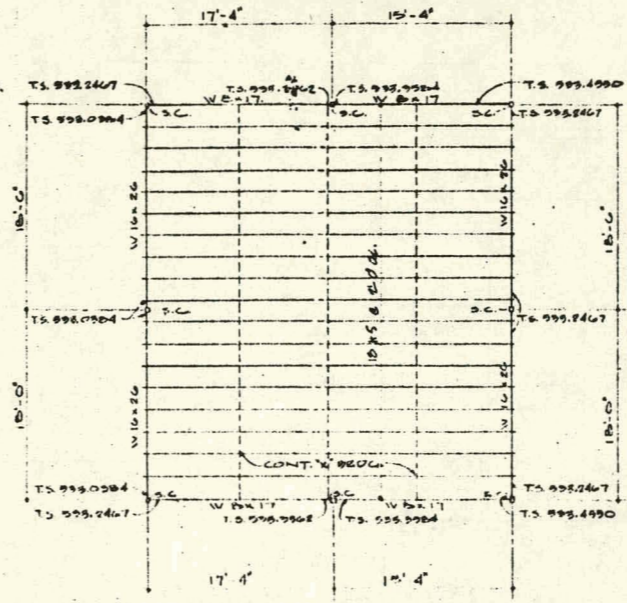

SECOND FLOOR ROOF FRAMING PLAN  
1/8" = 1'-0"

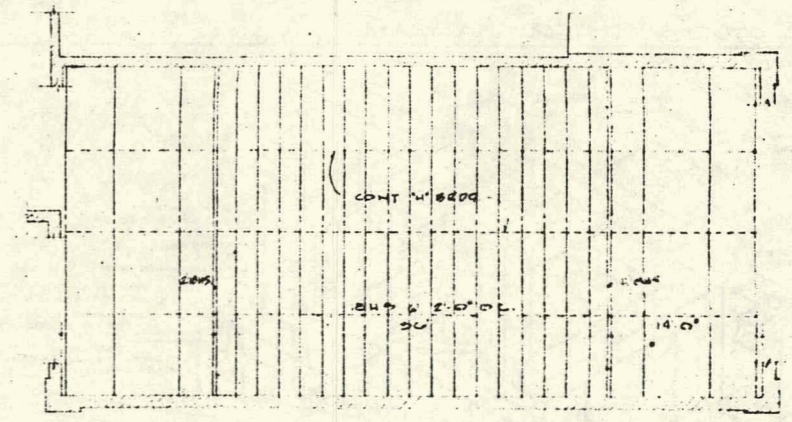

PARTIAL FIRST FLOOR ROOF FRAMING PLAN (APPARATUS ROOM)  
1/8" = 1'-0"

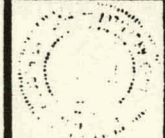

**GILLILAND-BELL ASSOCIATES, INC.**  
ARCHITECTS-ENGINEERS-PLANNERS-GREENWOOD, S.C.  
A. DALE GILLILAND, ARCHITECT | CHARLES A. BELL, ENGINEER

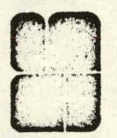

**MUNICIPAL BUILDING COMPLEX**  
SOLAR ENERGY SYSTEM  
City of Abbeville  
Abbeville South Carolina

SOLAR ENERGY SYSTEM SCALE: 1/8" = 1'-0" (NOT SHOWN)	
DATE 12-28-77	SHEET NO. B4
REVISED	OF TOTAL

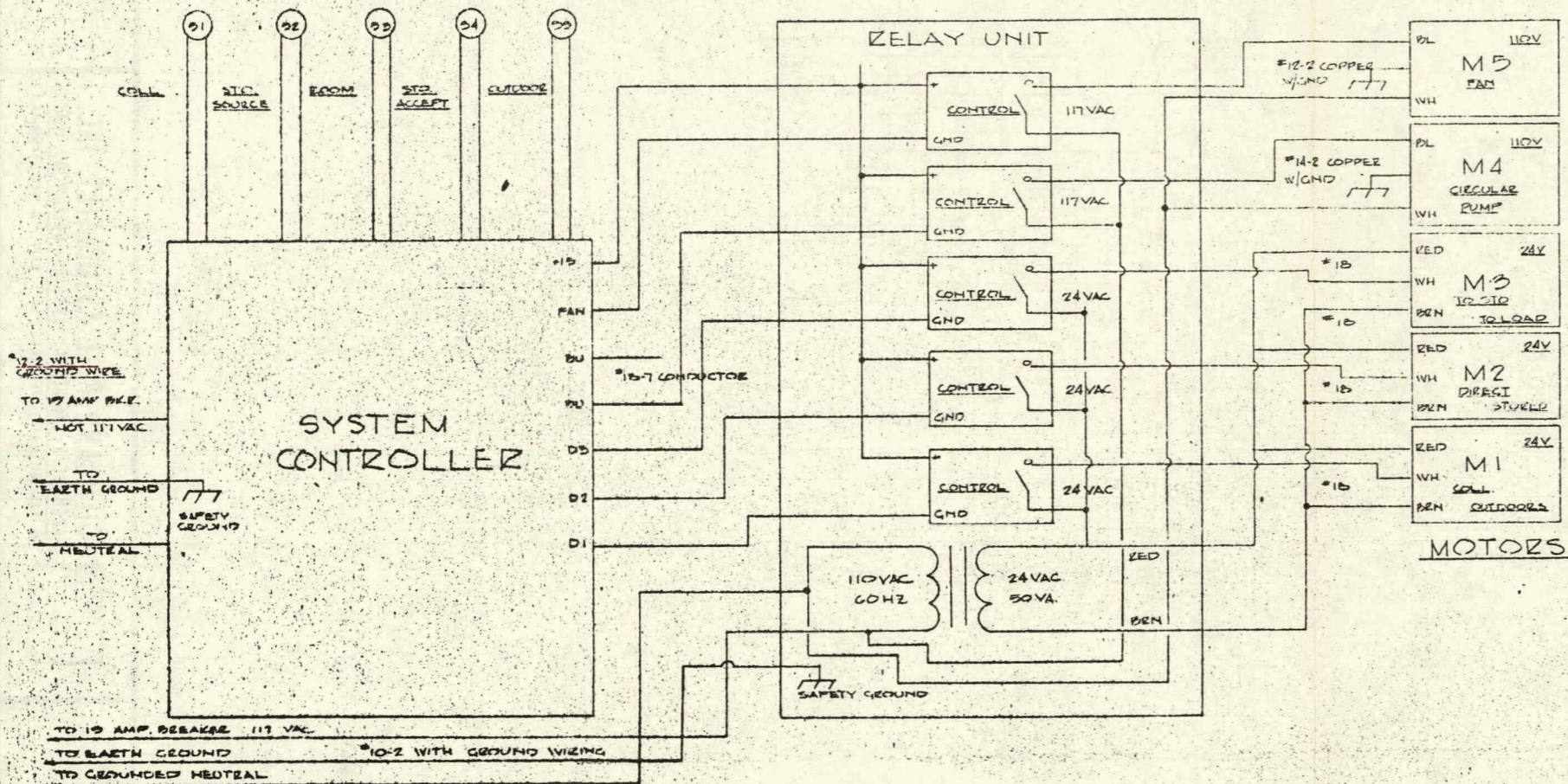

HEATING AND COOLING CYCLES

MODE	CYCLE	☺	☹	☺	☹	☺	☹
1	COLLECTOR TO BLDG. HEATING		OPEN		OPEN		OPEN
2	COLLECTOR TO STORAGE		OPEN	OPEN			OPEN
3	STORAGE TO BLDG.		OPEN		OPEN		OPEN
4	CONVENTIONAL		OPEN		OPEN		OPEN
5	OUTDOOR TO BLDG. COOLING		OPEN		OPEN	OPEN	
6	STORAGE TO BLDG.		OPEN		OPEN	OPEN	
7	AUXILIARY COOLING		OPEN		OPEN	OPEN	
8	STORAGE FRESH			OPEN	OPEN		OPEN

☺ GRAVITY DAMPER OPEN MODES 2, 5, 6, 8

ZONE/STAGE RETURN AIR OPERATION

ZONE 1	ZONE 2	RETURN AIR - ZONE 1	RETURN AIR - ZONE 2
SATISFIED	SATISFIED	RECIRCULATE	RECIRCULATE
STAGE ONE	SATISFIED	SOLAR RETURN	RECIRCULATE
STAGE ONE	STAGE ONE	SOLAR RETURN	SOLAR RETURN
STAGE ONE	STAGE TWO	SOLAR RETURN	RECIRCULATE
STAGE TWO	SATISFIED	RECIRCULATE	RECIRCULATE
STAGE TWO	STAGE ONE	RECIRCULATE	RECIRCULATE
STAGE TWO	STAGE TWO	RECIRCULATE	RECIRCULATE

NOTE: 1. ZONE HEAT PUMP OUTDOOR UNIT ACTIVATED WHEN STAGE TWO CALLED FOR. 2. IN RECIRCULATE OR BANG UP MODES - VISIBILE RETURN AIR DAMPER @ HEAT PUMP INDOOR UNIT IS OPEN.

SOLAR SYSTEM CONTROL DIAGRAM

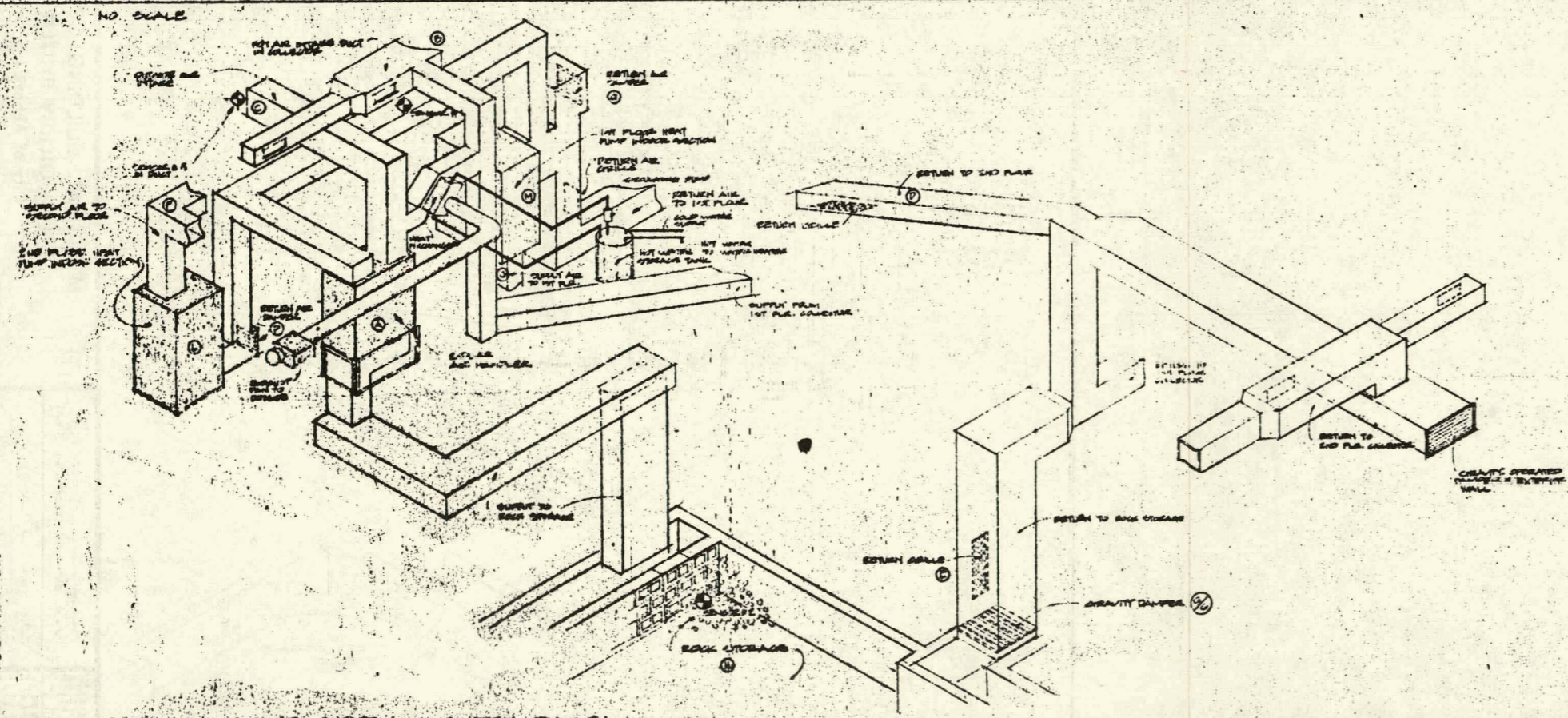

SOLAR SYSTEM ISOMETRIC DIAGRAM NOT TO SCALE

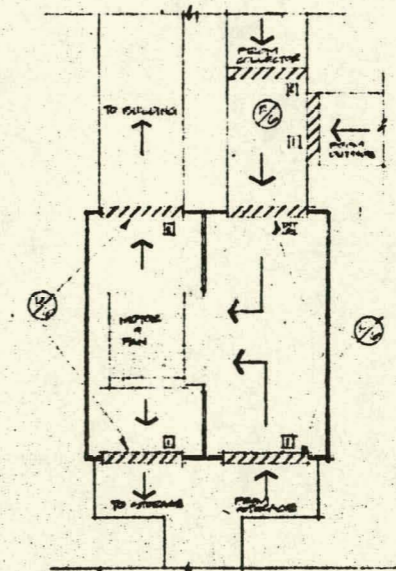

DIAGRAM SECTION THRU SOLAR AIR HANDLER NOT TO SCALE B5

GILLILAND-BELL ASSOCIATES, INC.  
 ARCHITECTS-ENGINEERS-PLANNERS-GREENWOOD, S.C.  
 A. DALE GILLILAND, ARCHITECT | CHARLES A. BELL, ENGINEER



MUNICIPAL BUILDING COMPLEX  
 SOLAR ENERGY SYSTEM  
 City of Abbeville  
 Abbeville South Carolina

SOLAR ENERGY SYSTEM  
 (FOR HEATING AND COOLING AT VARIOUS)  
 CONTROL DIAGRAM  
 SYSTEM OPERATING DIAGRAM  
 MODES AND CYCLES

COMM. 7641-A	SHEET NO. 5
DATE: 12/10/77	REVISED: 12/10/77
REVISED: 12/10/77	OF TOTAL

**APPENDIX C**

**OPERATING MODE TABLE**

**SYSTEM COMPONENT DIAGRAM**

**OPERATION MANUAL**

# OPERATING MODE TABLE

	MODE	CYCLE	HEAT PUMP AIR HANDLER		HEAT PUMP CONDENSER		SOLAR AIR HANDLER		DAMPER $\frac{S}{G}$ 1		DAMPER $\frac{S}{G}$ 2		DAMPER $\frac{D}{G}$ 1		DAMPER $\frac{D}{G}$ 2		DAMPER $\frac{E}{G}$ 1		DAMPER $\frac{E}{G}$ 2		DAMPER $\frac{G}{G}$		
			ON	OFF	ON	OFF	ON	OFF	OPEN	SHUT	OPEN	SHUT	OPEN	SHUT	OPEN	SHUT	OPEN	SHUT	OPEN	SHUT			
HEATING	1	COLLECTOR TO BUILDING	●		●			●		●			●	●		●		●			●		
	2	COLLECTOR TO STORAGE	●			●	●		●	●		●			●		●		●		●		
	3	STORAGE TO BUILDING	●			●		●	●		●		●	●		●		●		●		●	
	4	AUXILIARY HEATING	●		●			●	●		●		●	●		●		●		●		●	
COOLING	5	OUTDOOR TO BUILDING	●			●		●		●			●	●		●				●		●	
	6	STORAGE TO BUILDING	●			●		●	●		●		●	●		●		●		●		●	
	7	AUXILIARY COOLING	●		●			●	●		●		●	●		●		●		●		●	
	8	STORAGE PURGE	●			●	●			●	●		●		●		●		●		●		●

SYSTEM COMPONENT DIAGRAM

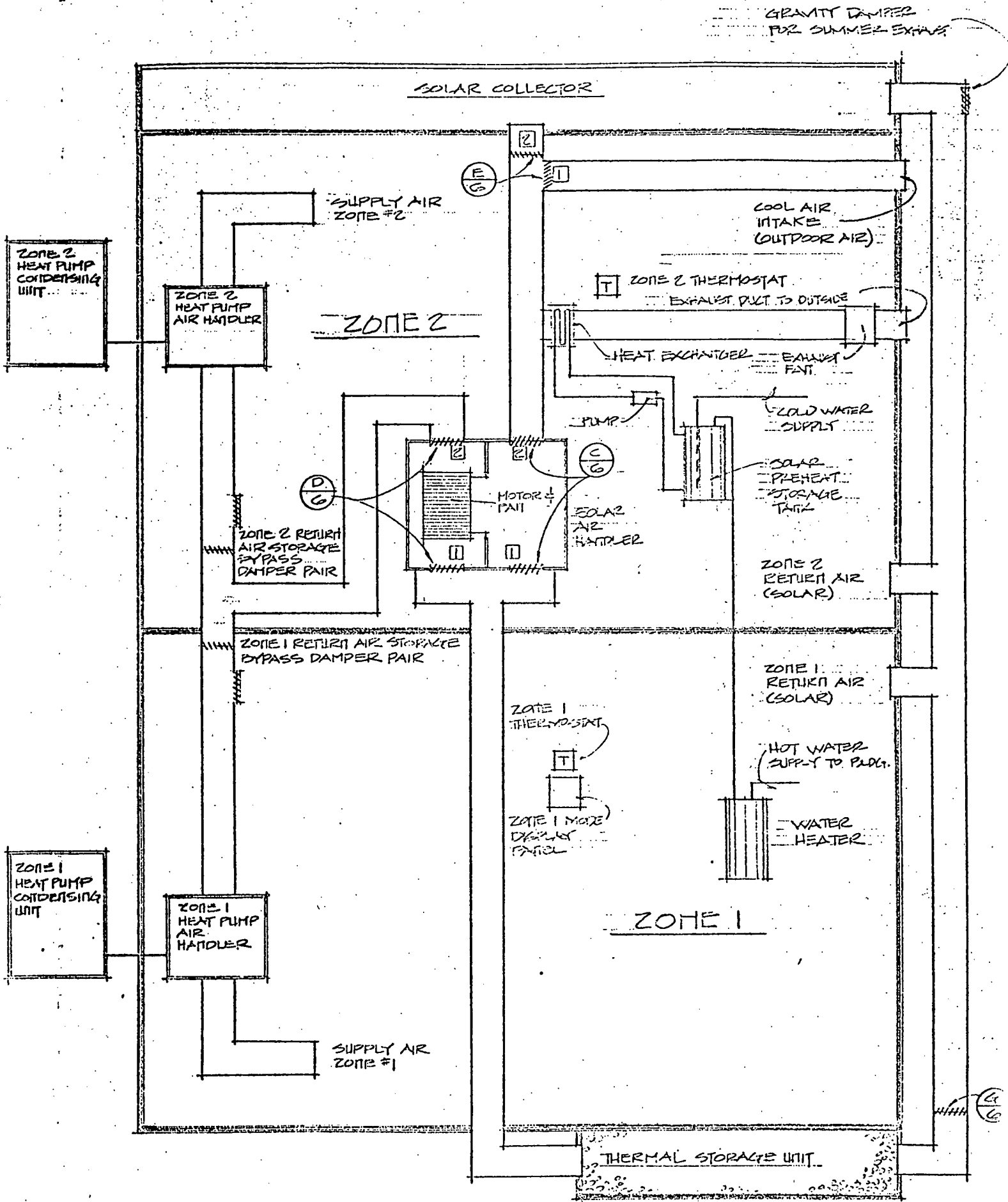

**INSTALLATION MANUAL**  
**FOR THE**  
**HELIO THERMICS AIR HANDLER**  
**MODELS 1200, 1900, 2900 & 3900**

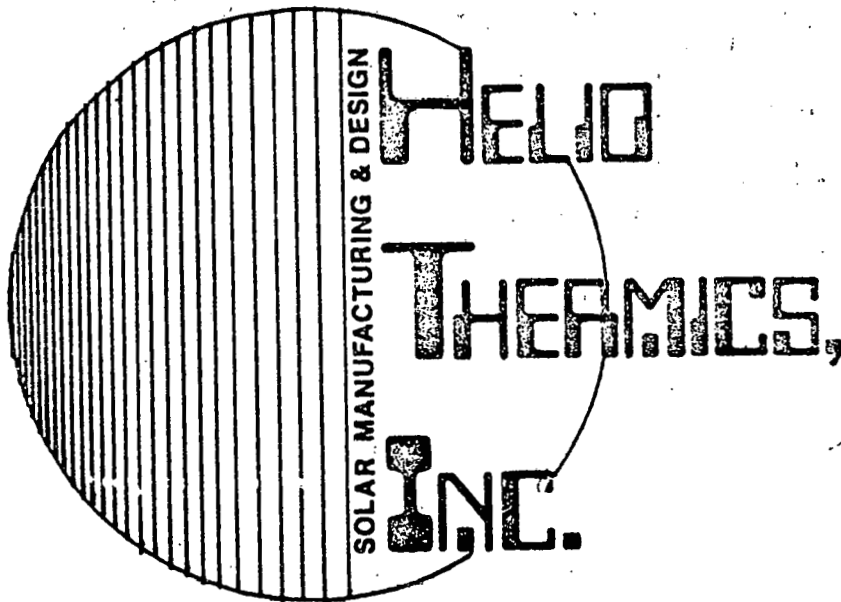

**CAUTION CAUTION CAUTION**

1. Do NOT TURN, ROTATE, or in ANY WAY MOVE DAMPERS, as they are connected to motors, and moving by hand WILL DAMAGE MOTOR. This will void warranty on the damper motors.
2. Do NOT APPLY POWER to unit until installation is COMPLETE.
3. Do NOT use 220 VAC with this system.
4. Make certain circuit breakers remain OFF until system is ready for activation.
5. Do NOT complete 110 VAC connection to Air Handler except as instructed in system activation procedure.
6. Check to make certain selector switch located on air handler is in the OFF position prior to beginning installation.
7. Do NOT allow moisture to contact electronic control. FAILURE TO FOLLOW THESE PRECAUTIONS CAN RESULT IN DAMAGE TO UNIT AND WILL VOID WARRANTY.

**UNPACKING UNIT**

Do not cut cardboard container with knife or sharp object, as wires attached to air handler could be damaged. Use metal cutting shears to cut bonding. Use pliers to remove staples or attachment on BOTTOM of corrugated box. Cardboard container should then LIFT OFF air handler.

Do NOT turn, rotate or in any way move dampers by hand, as moving them will damage damper control.

Remove sheet metal screws from brackets holding air handler to pallet.

If display panel and sensor wires are attached, LEAVE attached until unit is placed in its permanent position to prevent accidental damage or disconnection.

Set air handler in permanent location. (see next section-Placing the Unit)

When wiring is to be run, remove packing material from sensor wiring and panel display, and proceed with wiring instructions.

## PLACING THE UNIT

The Air Handler can be installed in any position, however, to minimize stress on the bearings, it is recommended that mounting positions below be used if practical.

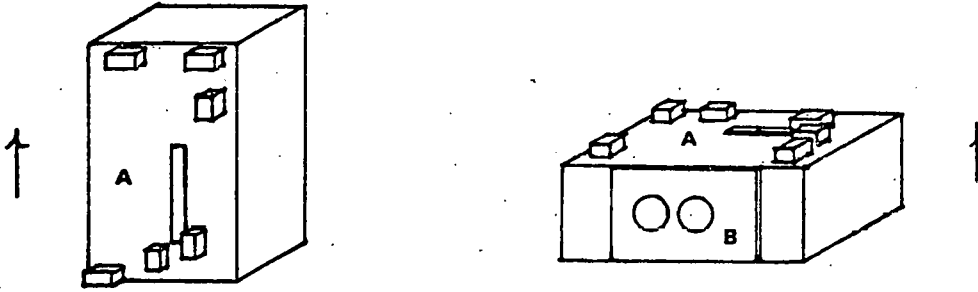

PREFERRED MOUNTING POSITIONS

Keep in mind that there must be a minimum of 2 feet of access area to the air handler on two sides (labeled A and B in preceding diagram) the side with the damper control motors, filter and selector switches, and the side with the control access panel. This can be accomplished by placing the Air Handler in a closet which allows 2 feet of clearance on those two sides, or a combination of such spacing, doors, or removable panels.

The location should be at a point between the storage and collector to keep the collector-to-air handler duct as short as possible. The duct from outside to the air handler should be installed in the controlled environment of the structure (as in a dropped ceiling or through a closet). If practical, the duct from the outside to the air handler should open on the north side to pick up the coolest temperatures available.

**CAUTION:** Do not install the air handler in the attic or collector area where the warm temperature from the solar radiation will have an adverse affect on the air handler electronics and the air passing through the duct.

Where a cool air duct is run through an attic, there may be a problem of picking up the surrounding heat. By running this duct through a controlled space, this potential problem is eliminated.

If the air handler is located on the floor, rubber mounting pads must be used. If located in a horizontal position, the supply-to-house and supply-to-storage openings must be fitted with duct mounting flanges to insure that opening and closing of damper blades is not restricted by the duct work.

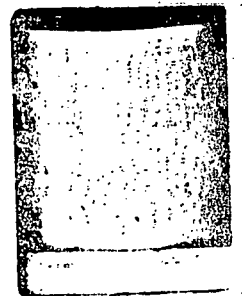
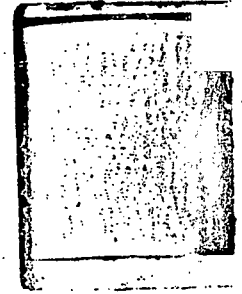

### **BACK-UP HEAT**

An in-line electric resistance duct heater can be installed in the supply-to-house duct. When the air handler is placed in a vertical position, raise the air handler about 18" above the floor line and install the duct heater in the duct 8 inches from the air handler (be sure to mount according to manufacturers' instructions and comply with applicable codes and safety precautions).

### **BACK-UP COOLING**

A split air conditioner can be used for cooling by installing the indoor coil in the supply-to-house duct. If both heating and cooling coils are installed, the supply air flow should first pass through the cooling coil. Mount the unit as per manufacturers' recommendations.

### **HEAT PUMP**

The coil may be installed in the supply-to-house duct as mentioned above, or in the storage inlet-outlet duct.

### **WIRING**

See specific model for CFM, wire size and circuit amperage.

### **SENSOR WIRING - PRECAUTIONS AND PROCEDURES**

**PRECAUTIONS:** The sensor probe wires are light gauge and should be treated with care. They should not be pulled excessively during installation. They should not be squeezed temporarily or compressed under cable staples to a high pressure. When these simple handling guidelines are followed, the sensor cables should be dependable for the life of the system.

If local codes require low voltage wiring be enclosed in conduit, conduit should be used to protect the sensor cable. Do not run sensor wires inside conduit carrying any other conductors (power, intercom, etc.) to prevent interference. When installing wiring, do not run sensor cables near power wiring. If it is unavoidable, separate the sensor wires as far as possible from the power wiring conductors. (minimum - 3 feet) Sensors have less than one volt signal voltage and are quite safe and free of shock hazards while operating (sensors are at ground potential - do not allow sensor probe body to contact high voltage).

The sensor cables may be run through walls, ceiling, attics, floors, etc., provided the above guidelines are kept in mind. Terminate all sensor cables inside the controller enclosure.

### **COLLECTOR SENSOR PLACEMENT - SENSOR 1**

The collector temperature sensor is labeled sensor 1. The collector temperature sensor is placed in the collector outlet airstream, and is mounted with an angle iron bracket to the interior of the outlet duct. (see illustration)

A no.6-32 x 1/2" machine screw, nut and lock washer (to prevent loosening by vibration) should be used to attach sensor to the mounting bracket. The

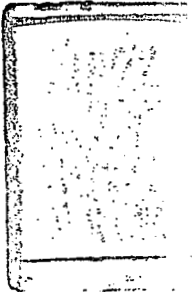

mounting bracket is attached to the interior of the outlet duct opening with appropriate hardware. Sensor probe should be mounted so that it is in the center of the duct opening. A nylon 1/4" cable clamp should be used as a sensor cable strain relief to prevent movement of sensor after installation.

#### **STORAGE SENSORS (2 and 4) - SOURCE AND RETURN**

The storage source is labeled sensor 2, and the storage return is labeled sensor 4.

Two pieces of 3/4" rigid conduit (non-corrosive) must be positioned prior to installation of rock fill so that temperature sensor probes may be installed later. The storage source sensor thermowell tube should be placed so that when the sensor probe is inserted fully it will lie about ten inches (not less than 5 inches) from inlet plenum. The storage return sensor thermowell tube should be placed so that when the sensor probe is inserted fully, it will lie inside the storage return air plenum chamber. NO BENDS should be made in these tubes. The length should be as short as possible. It should be appropriately capped to prevent debris from entering until sensors are ready to be inserted. ALLOWANCE MUST be made during sensor tube installation and all subsequent installation steps to INSURE ACCESS for SERVICE. This could be near a floor register, or in a closet with a removable access door.

A 1/4" nylon cable clamp should be attached within 6 inches of probe. Sensor probes will be placed at the bottom of each conduit and the conduit plugged to prevent air leakage when the storage unit is complete.

The sensors that will be installed in these thermowell tubes are four inches long. (see illustration)

If local codes require conduit tubes for low voltage circuits, clearance must be provided for a weather head or similar device.

#### **ROOM TEMPERATURE SENSOR - SENSOR 3**

The room temperature sensor is labeled sensor 3. The room temperature sensor differs from the other four sensors. It is encased in a small metal can approximately 1/2" in diameter. This sensor is installed as follows: (see illustration)

Select a site on the interior wall of the house which is about 5 to 6 feet from floor level, on the main floor of the building. This site should be away from the registers and away from all sources of heat such as lights, appliances, television sets, or anything which would alter room temperature locally. Install standard wiring box at selected site. Room temperature sensor may be located anywhere a conventional thermostat would be located.

Sensor wire should be run through the walls and/or ceiling of the house back to the controller enclosure. If local codes require conduit protection of low voltage wiring, sensor wiring should be run inside conduit. Do not run sensor wiring inside same conduit as power wiring or within three feet of power wiring conductors.

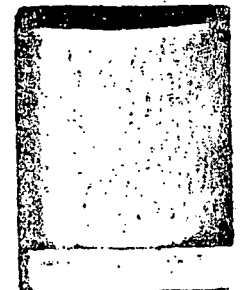
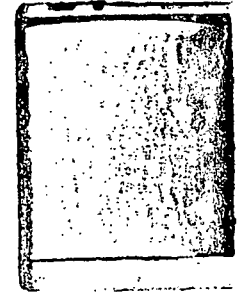

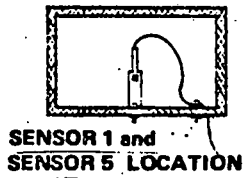

**SENSOR 1 and  
SENSOR 5 LOCATION**

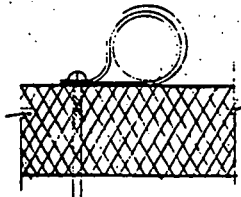

**SENSOR CABLE STRAIN RELIEF**

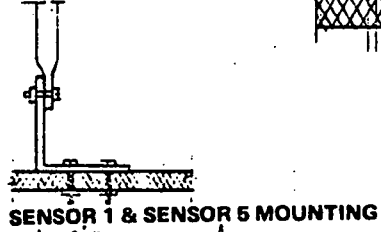

**SENSOR 1 & SENSOR 5 MOUNTING**

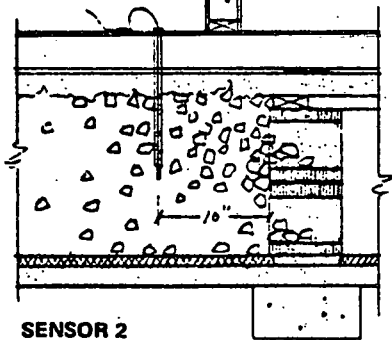

**SENSOR 2  
STORAGE SOURCE SENSOR**

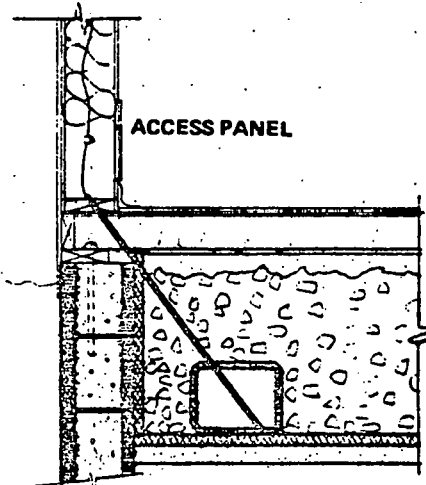

**ACCESS PANEL  
SENSOR 4  
STORAGE RETURN SENSOR**

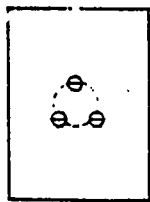

**ROOM SENSOR MOUNTING PLATE  
FRONT VIEW**

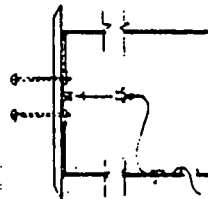

**SENSOR 3  
ROOM SENSOR MOUNTING**

## OUTDOOR AIR TEMPERATURE SENSOR PLACEMENT - SENSOR 5

The outdoor air temperature sensor is labeled sensor 5. (see illustration) The sensor is installed behind the north wall air intake grill inside the cool air intake duct. This probe should be positioned so that it is in the center of the duct opening within two inches from the exterior grill. The sensor probe should be mounted to the duct with an angle bracket of the proper size, using a no. 6-32 x 1/2" machine screw, lock washer and nut to mount sensor to bracket, and appropriate hardware to mount bracket to duct. A nylon 1/4" cable clamp should be installed as a strain relief within one foot of sensor probe body to prevent movement of sensor after installation.

Outdoor sensor wire should be run back to controller enclosure through walls, ceiling, etc., as described in the Sensor Wiring Precautions and Procedures section.

If system is not designed for cooling, there will be no sensor placement.

## CONTROL PANEL INSTALLATION

The thermostat control panel is the temperature adjustment and mode indicator panel. Supplied with the control panel is a galvanized steel mounting ring which is installed after the house is framed and before the electrical wiring is completed.

This mounting ring is installed at the appropriate location within 25 feet of the location of the air handler. It is nailed with eight penny common nails to the studs approximately five feet from floor level. The ring should be installed with the depression toward the inside of the wall. (see illustration) Approximately 3/16" should be chiseled from the surface of the stud to allow mounting plate to be recessed flush with the stud surface. Wiring for thermostat display is run from Air Handler location to the mounting ring location, and sheet rock is then applied.

For model 1200, a conventional thermostat is used.

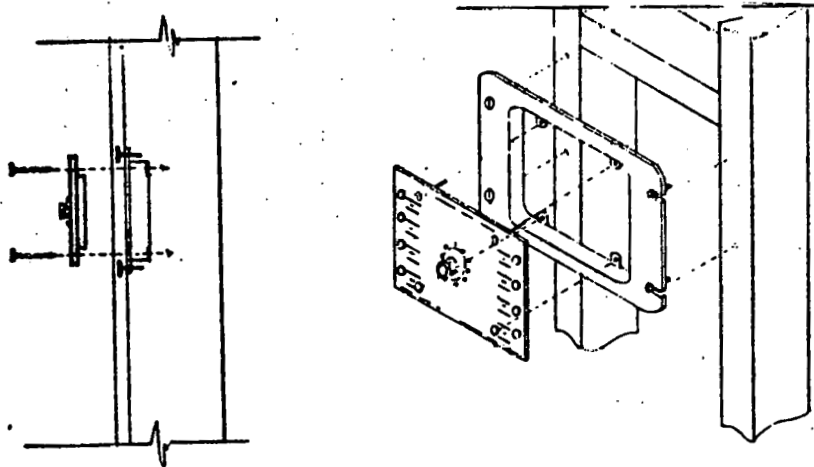

CONTROL PANEL INSTALLATION

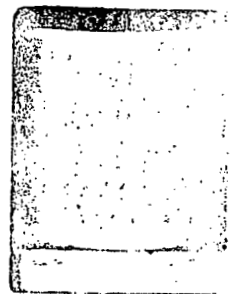
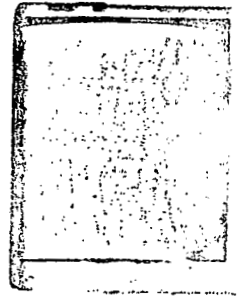

## POWER SUPPLY WIRING

110-120 VAC, single phase, 50 to 60 cycle power must be provided for controller and air handler.

There is one power supply line which supplies 110 volt AC power to the controller - air handler. This wire must be made of copper conductor and have U.L. approved insulation rated at 1500 volts AC and to temperature of 200° F.

The wire must be run in metal flexible conduit from breaker panel to the controller - air handler.

Hot wire is to be black, neutral wire white, and ground wire is to be uninsulated.

The wire from the panel to the air handler varies in size with the distance from air handler to panel and with model number. (see illustration)

MODEL	HP	25 FEET	50 FEET	100 FEET	150 FEET	200 FEET
1200	½	10	10	8	6	6
1900	½	10	10	8	6	6
2900	¾	10	10	8	6	4
3900	1.0	10	10	6	4	4

**NOTE: ALL WIRE MUST BE COPPER CONDUCTOR  
ALL WIRE SIZES ARE AWG GUAGES**

All procedures and specifications herein shall be followed except where in variance with local codes. However, above wire sizes are minimum permissible. Use larger size where local codes require.

A separate breaker must be used for this air handler and controller, a 15 AMP MINIMUM. Do not use this breaker for any other circuit.

## DUCTWORK

Install ductwork to comply with blueprint plans, specifications, and local codes as applicable.

The supply ductwork is conventional, however the collector-storage and return ductwork will be as per plans.

It is recommended that SMACNA "Installation Standards for One and Two Family Dwellings and Multifamily Housing including Solar" be used.

## BACK-UP HEATING/COOLING INSTALLATION

The relay control panel inside the air handler service access panel contains two terminal blocks which supply a 24 VAC control signal (24 VAC at 250 milliamperes (.25A) per output maximum) to activate a backup heating unit or backup heating/cooling unit. The 24 VAC circuit is fused with a 1.0 AMP fuse located on the relay panel to protect unit from excessive current draw at the backup control outputs.

It is recommended that a time delay relay with coil current of 250 milliamperes or less, at 24 VAC; at least a 10 second time delay; and a set of normally open contacts be used for the heating backup and cooling backup. When contact closure is required by backup heating appliance or backup cooling appliance, the relay contacts provide the thermostat signal. When voltage input is necessary, the relay contacts and a transformer of the proper voltage and current is used. (see illustration)

For an electrical resistance heater backup with a sequencer system built in, a time delay relay is not necessary and a non-delay normally open contact relay will suffice. This relay should have a 24 VAC coil and draw less than 250 milliamperes when energized. The normally open contacts should be capable of switching the current necessary to activate the backup appliance it is to be used with.

Use no. 18 gauge twisted pair stranded control wire to make the connection between the air handler output terminals and their respective relays. This is low voltage control wiring, and wiring should be in accordance with applicable codes.

Refer to blueprint enclosed with unit for terminal block identification.

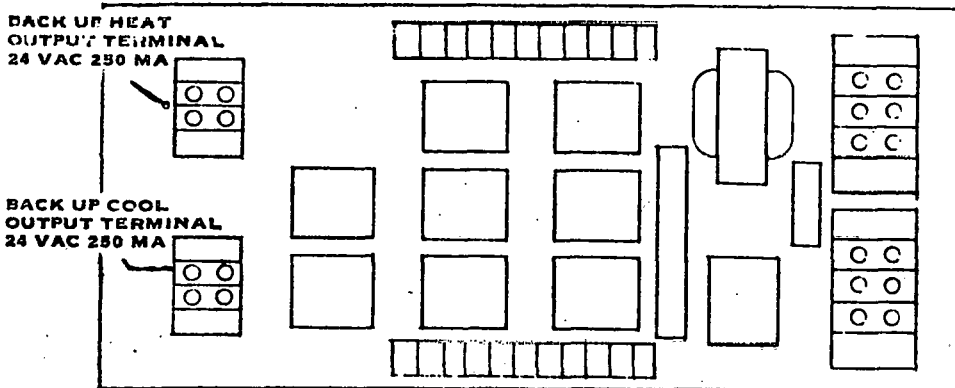

1. HEAT PUMP

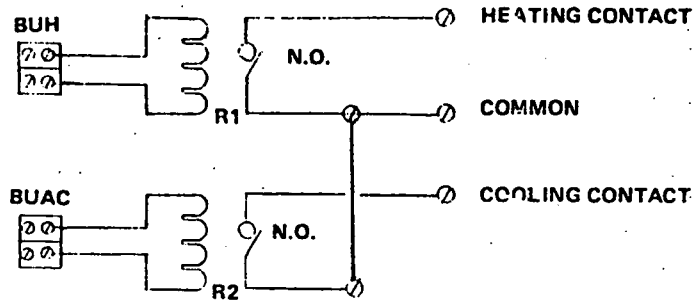

3. OIL OR GAS FURNACE

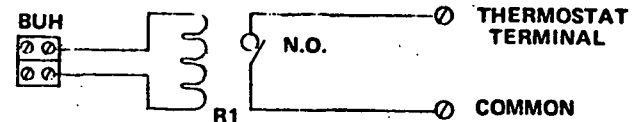

2. AIR CONDITIONER

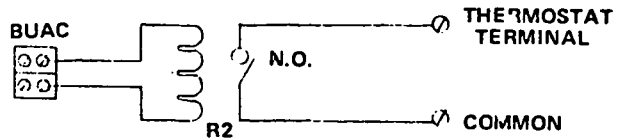

4. ELECTRIC DUCT HEATER

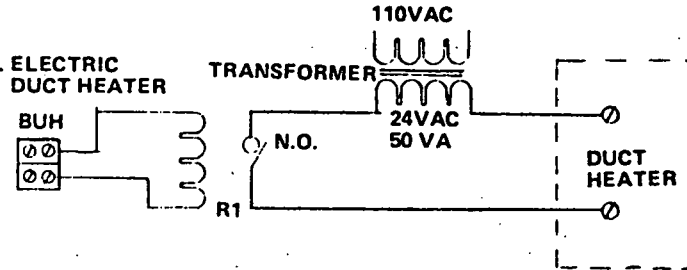

5. HYDRONIC

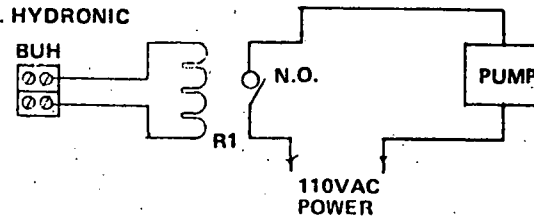

BACK-UP SYSTEMS CONTROL WIRING

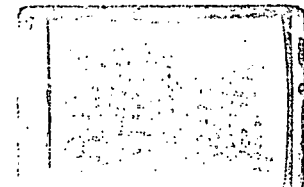
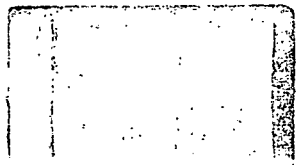

## SYSTEM ACTIVATION

1. Check to make sure air handler selector switch is in OFF position, and that all preceding instructions have been complied with.
2. Connect AC volt meter to the 110 VAC power supply circuit. (wire coming out of box in wall).
3. After making certain that air handler is NOT connected to POWER SUPPLY circuit, momentarily turn air handler breaker to ON to verify 110 VAC (and not 220 VAC).
4. Turn air handler breaker OFF.
5. Make power supply connection from electrical box on wall to air handler makeup box. Make sure local codes are complied with.
6. Check all wiring to make sure it is properly installed — that there are no loose connections or wires touching that could be shorted.
7. Turn air handler breaker to ON position.
8. Turn backup heat breaker to ON position.
9. Turn backup cooling breaker to ON position (if installed).
10. Turn selector switch on air handler to Emergency backup position to verify operation of backup source and air handler.
11. Now turn selector switch on Air Handler to ON position, and storage switch to Heat position (for winter operation) or Cool position (for non-heating season).
12. Set thermostat to desired temperature .
13. Enjoy solar heated comfort and economy.