

DOE/ET/20279--208

DOE/ET/20279-208

DE82 018134

Distribution Category UC 63a-e

**DATA REPORT FOR THE
NORTHEAST RESIDENTIAL EXPERIMENT STATION —
MARCH 1982**

June 1982

**M.C. Russell
P. Raghuraman
P.C. Mahoney**

DISCLAIMER

This report was prepared as an account of work sponsored by an agency of the United States Government. Neither the United States Government nor any agency thereof, nor any of their employees, makes any warranty, express or implied, or assumes any legal liability or responsibility for the accuracy, completeness, or usefulness of any information, apparatus, product, or process disclosed, or represents that its use would not infringe privately owned rights. Reference herein to any specific commercial product, process, or service by trade name, trademark, manufacturer, or otherwise, does not necessarily constitute or imply its endorsement, recommendation, or favoring by the United States Government or any agency thereof. The views and opinions of authors expressed herein do not necessarily state or reflect those of the United States Government or any agency thereof.

**Massachusetts Institute of Technology
Lincoln Laboratory
Lexington, Massachusetts 02173-0073**

**Prepared for
THE U.S. DEPARTMENT OF ENERGY
UNDER CONTRACT NO. DE-AC02-76ET20279**

DISTRIBUTION OF THIS DOCUMENT IS UNLIMITED



DISCLAIMER

This report was prepared as an account of work sponsored by an agency of the United States Government. Neither the United States Government nor any agency thereof, nor any of their employees, makes any warranty, express or implied, or assumes any legal liability or responsibility for the accuracy, completeness, or usefulness of any information, apparatus, product, or process disclosed, or represents that its use would not infringe privately owned rights. Reference herein to any specific commercial product, process, or service by trade name, trademark, manufacturer, or otherwise does not necessarily constitute or imply its endorsement, recommendation, or favoring by the United States Government or any agency thereof. The views and opinions of authors expressed herein do not necessarily state or reflect those of the United States Government or any agency thereof.

DISCLAIMER

Portions of this document may be illegible in electronic image products. Images are produced from the best available original document.

Blank Page

ABSTRACT

The Residential Experiment Stations of the Solar Photovoltaic Residential Project have been designed by MIT Lincoln Laboratory under Department of Energy sponsorship to develop residential photovoltaic systems and to gather and disseminate performance data for the photovoltaic community, cognizant institutions and, ultimately, the public. This report tabulates physical performance data for the month of March 1982 obtained from photovoltaic energy systems under test at the Northeast Residential Experiment Station in Concord, Massachusetts.

1.0 INTRODUCTION

MIT Lincoln Laboratory, under the aegis of the U. S. Department of Energy, has established a Residential Experiment Station (NE RES) in Concord, Massachusetts, to monitor the performance of state-of-the-art residential solar photovoltaic (PV) energy systems. The attached information presents one month of physical data obtained at the NE RES for these systems. It includes a one-page summary, detailed hour-by-hour tabulation for an averaged day for the month, and a monthly load duration curve for each of the loads being monitored. This report is distributed to the NE RES Consulting Committee, the other field centers in the PV program, the Jet Propulsion Laboratory Lead Center, the Department of Energy (DOE) and the technical community involved in the development of PV energy systems. The objective of this report is to disseminate authoritative and accurate information concerning the performance of residential PV systems and the typical loads which they serve. Such timely information is needed by the overall DOE PV Program to ensure a uniform and correct understanding of the performance of these developmental systems.

Five prototype residential PV systems are presently under test at the NE RES. Each of these Prototype Systems consists of a roof-mounted PV array, sized to meet at least 50% of the annual electrical demand of an energy-conserving house, and an enclosed structure to house the remainder of the PV system equipment, test instrumentation and work space. Four of these PV systems were designed and built by industry participants in the Lincoln Laboratory project; the fifth prototype was designed in-house. The arrays provide dc energy which is converted to ac energy by power-conditioning equipment to service all the usual loads of the residence. A common feature of all the Prototype Systems is that excess solar-generated electric energy is fed back to the local utility grid, thereby eliminating the need for on-site storage. To gauge quantitatively the ability of the Prototype Systems to meet residential load demands, five houses in the vicinity of the NE RES, representative of the occupancy and loads found in the area, have been equipped with instrumentation which continually records their electrical energy consumption. Telephone lines carry load information from these

monitored residences to the NE RES where the data are assimilated. One of the monitored houses is chosen to command the same programmable load profile for each Prototype System, thereby simulating a typical residential electrical load and permitting side-by-side comparison of the prototypes under essentially identical conditions.

In addition to the prototypes and monitored houses, one full-sized PV residence--the Carlisle House--is also being monitored. This house in Carlisle, Massachusetts, was provided with a PV system as part of the MIT Lincoln Laboratory Solar Photovoltaic Residential Project and will be monitored for up to five years.

Features of the Prototype Systems and monitored houses are listed in Tables 1 and 2, respectively.

Figure 1 illustrates the sequence by which the attached monthly data reports are generated from the data obtained from the Prototype Systems and monitored houses. Data is measured every five seconds which is then averaged over 6-minute intervals. These 5-second and 6-minute data are then processed resulting in the figures and tables in this report. Table 3, NE RES Monthly Summary, presents a tabulation summarizing the monthly performance of the PV systems and monitored houses, as well as meteorological data. For comparison, long-term average Boston weather data (References 1,2) is also included. Table 4 gives a definition for each quantity reported in the NE RES Monthly Summary, explaining how it is derived. Those quantities whose definitions are not self-explanatory are explained in detail in Section 2, "Computational Basis for Report." Table 5, Brief Monthly Report, presents an hour-by-hour tabulation of information for an average day of the month. It includes Monitored House and Prototype Systems Data. Also included is a table that presents the hypothetical energy exchange if each prototype system supplied energy to each monitored house. Figure 2 presents graphically this same hypothetical energy flow data. The monthly load duration curves, Figure 3, for each monitored house use only 5-second data and illustrate the duration of time for which the load had a specific value. The quantities measured at the monitored houses and presented here are

TABLE 1

FEATURES OF THE PHOTOVOLTAIC ENERGY SYSTEMS IN THE
NORTHEAST PROTOTYPES AND THE INITIAL SYSTEM EVALUATION EXPERIMENT
AT CARLISLE, MASSACHUSETTS

Photovoltaic System	Module Supplier	Array Area (m ²)	Rated Array Peak Power (kWp)	Mounting Method	Array Tilt (deg)	Inverter Supplier	Inverter Size (kVA)
General Electric	General Electric	76.8	6.7	Direct	33.7	Abacus	6
MIT LL	Solarex	84.9	6.8	Standoff	45.0	Windworks	8
Solarex	Solarex	68.4	5.0	Standoff	40.0	Abacus	6
TriSolarCorp	Applied Solar	47.2	4.8	Integral	45.0	Windworks	8
Westinghouse	ARCO Solar	69.2	5.1	Integral	45.0	Abacus	6
Carlisle House	Solarex	97.0	7.8	Standoff	45.0	Windworks	8

TABLE 2

MONITORED HOUSES FEATURES

	MH2	MH3	MH4	MH5	MH6
Occupants	5	5	4	5	4
Working Adults (Daytime Hours)	2	2	1	2	1
Heating System	Oil	Oil and Electric (2 rooms)	Oil	Oil	Oil
Domestic Hot Water System	Electric	Electric	Oil	Electric	Oil
Cooking	Electric	Electric	Electric	Electric	Electric
Clothes Drying	Electric	Electric	Electric	Electric	Electric
Air Conditioning	None	None	Window	None	Window

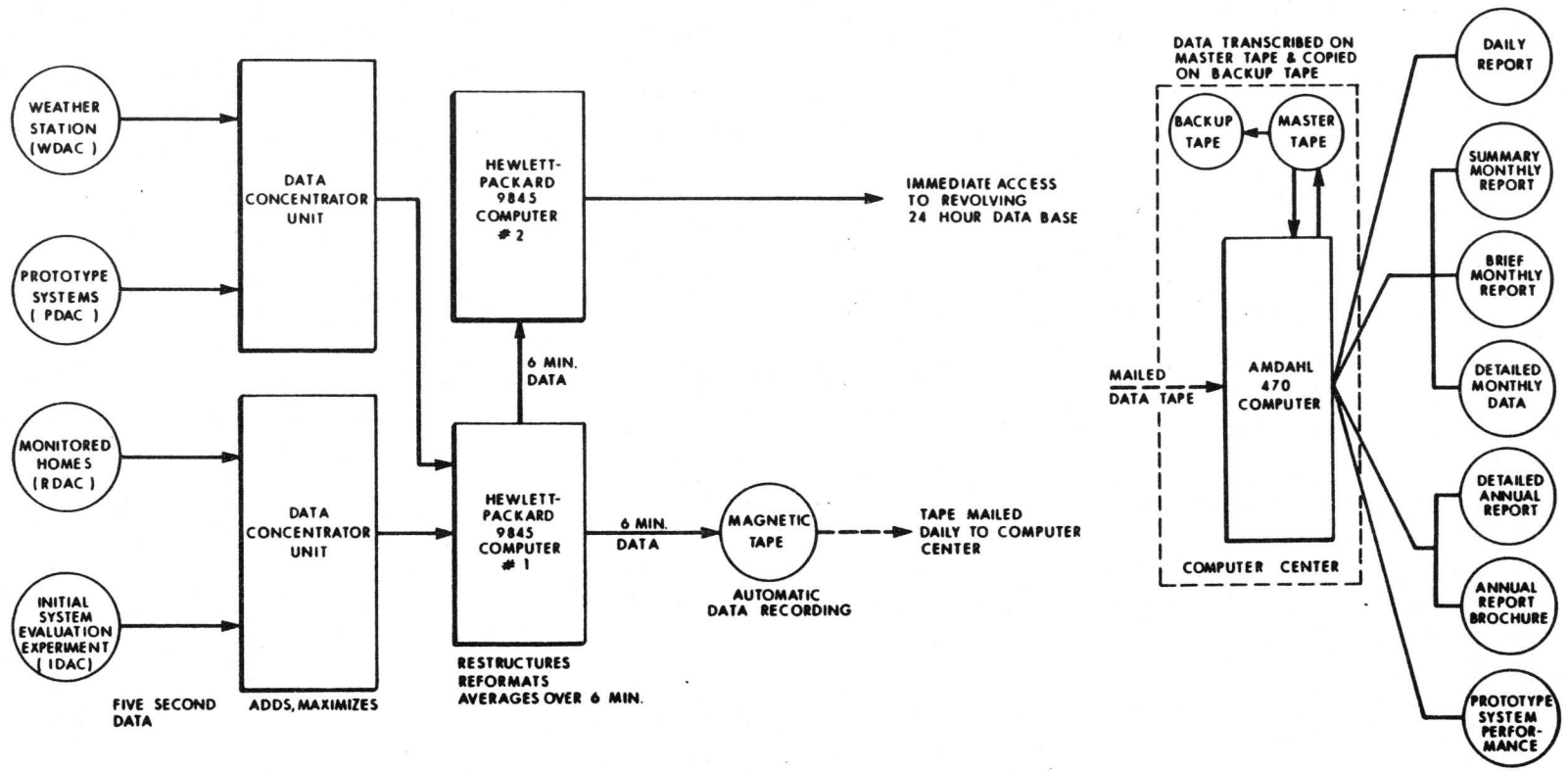

FIG.1 FLOW CHART FOR DATA ACQUISITION & REPORTING OF RES & ISEE OPERATIONS

C74-1629

intended for use by both electric utilities and PV system designers. This information will be particularly useful in the numerical simulation of PV system performance and in determining the ability of these systems to meet actual residential loads. The information concerning the prototypes and the Carlisle House is intended for use by PV system designers and electric utilities as well as by institutional observers and the institutions represented on the RES Consulting Committees. It is expected that this information will provide a basis for understanding the performance implications for the different prototype designs.

The following section provides a discussion of the methods of data analysis and reduction used to generate the data provided in this report. Background information on the hardware design of the entire data collection system is contained in Reference 3. Additional information on the retrieval, processing and dissemination of data collected by the residential data system is contained in Reference 4. Copies of these reports and additional information on the PV systems activity at MIT Lincoln Laboratory are available upon request by writing to the address below:

Solar Photovoltaic Residential Project
MIT Lincoln Laboratory
Room D-437
P.O. Box 73
Lexington, MA 02173

The following section presents a discussion of the computational philosophy underlying the data contained in this report.

2.0 COMPUTATIONAL BASIS FOR REPORTS

The majority of the values presented in this report result from either an averaging or a peak-seeking process. Further, they are calculated under conditions in which some or all data may be intermittently missing because of maintenance or unavailability of the data system. Data may also be marked as invalid for reasons such as sensor failure, calibration errors, and experiments or repairs being done while data are being recorded. Because of the characteristics of the data, a detailed description of the ground rules used in the generation of this report should add to the meaningfulness of the results.

2.1 NE RES Monthly Summary

To adapt to missing or invalid data, some of the results reported in the Monthly Summary are computed only over time periods when data from a critical group of the quantities used in their computation are all available and valid. This is done to maintain consistency in those results by ensuring that they are computed over coincident time intervals. There are two such groups described below. The length of time for which the data were used in computation is included in the report either in hours or as a fraction of total time possible. Note that the time given for each monitored house or prototype system applies only to that specific site.

Specifically, in the ARRAY AND POWER CONDITIONING UNIT subsection of the PHOTOVOLTAICS SYSTEMS INFORMATION section, values for the group of inputs comprised of tilt insolation, array dc output power (note that energy is computed by integrating the recorded successive power values) and PCU ac output power for a prototype are all required to be available at the same time before they contribute to the calculation of the following values in that subsection:

- Average daily array dc energy output
- Average daily array dc energy output/Rated
array power
- Average daily insolation during system on-hours
- Insolation utilization efficiency
- PV array efficiency
- Average daily PCU ac energy output
- PCU efficiency
- Array and PCU data hours during sunhours.

Similarly, under the PV SYSTEM UTILITY ENERGY FLOW subsection, values for the group comprising PCU ac output power, power to utility, power from utility, and power to load must all be simultaneously available to be included in calculation of all values reported in the subsection.

Note that PCU ac output power is a constituent of both groups of required quantities. However, it might not appear in the two groups over precisely the same time intervals because of the grouping constraints. Therefore, the two values reported for it may differ and cross checks based on it may not prove out.

Table 4 gives a definition for each quantity reported in the Monthly Summary, explaining how it is derived. Those quantities whose definitions are not self-explanatory are explained in more detail below. For background information on the data system, readings are recorded across all physical quantities in the entire system every 6 minutes. The values stored for a quantity are either the average value seen over the 6 minutes or the highest value, depending on how they were predefined. These values are referred to as 6-minute averages and 6-minute peaks, respectively. Energy computations use values calculated by integrating successive 6-minute average readings; other reported quantities use the recorded readings directly. Some general comments clarifying the definitions given in Table 3 are presented below:

- o Average of highest 6-minute-peak (or average) readings for each day:

The highest value is selected for each day of the month and the selected values are averaged. For selected quantities indicated by an "*", the day is ignored if there is a gap in the data longer than one hour between 10 a.m. and 2 p.m. local standard time.

- o Average of all readings for month:
Equal weight is given to each valid value.

- o Sum of average-hour values for month:
This formulation is used to derive the average daily total values in the report. First, all valid input

data values for the month are accumulated by the hour in which they were taken. Then an average is calculated for each hour, giving a 24-point profile for an average day for the month. These values are called average-hour values and are used in the Brief Monthly Report. The average-hour values are summed to yield the average daily totals. It is probable that different numbers of values will participate in the averaging calculations for various hours over the month because of the randomness of data losses. As a result the daily averages formed this way will differ from those that would result from giving equal weight to all data points, but should yield a more representative profile by smoothing out the effects of daytime maintenance and experimentation data outages.

2.2 NE RES Brief Monthly Report

In contrast to the Monthly Summary, the Brief Monthly Report processes as much of the data as is available for any quantity, without constraints on data for other quantities being simultaneously available. This is done in order to preserve the maximum amount of valid data for each reported quantity. One result of this is that, unlike the Monthly Summary, energy balances in the Brief Monthly Report can not be expected to check out. There are two quantities which are treated as exceptions to this rule, namely, energy supplied to utility and energy supplied by utility. These quantities are processed only when all four of the following are available: AC inverter output, load imposed on prototype, energy supplied by utility and energy supplied to utility. All the other quantities are unaffected by this rule. In view of the difference in the data processing ground rules for computing the Monthly Summary and Brief Monthly Report, it is probable that the daily totals from the Brief Monthly Report will not agree precisely with the values in the Monthly Summary.

REFERENCES

1. Knapp, C. L., et. al., "Insolation Data Manual," Solar Energy Research Institute, SERI/SP-755-789, October 1980.
2. "Weather of U.S. Cities," Volume 1, Gale Research Company, Detroit, Michigan, 1981.
3. Fenton, H. A. and Much, C. H., "Residential Photovoltaic Experiment Station Data System," MIT Lincoln Laboratory Report No. DOE/ET/20279-155, September 1981.
4. Raghuraman, P. and Kern, E. C., "Information Gathering, Data Reduction and Information Dissemination for Residential Experiment Station Operations," MIT Lincoln Laboratory Report No. DOE/ET/20279-141, June 1981.

Fig. 2
 HYPOTHETICAL ENERGY FLOWS
 IF PROTOTYPES WERE INSTALLED AT MONITORED HOUSES

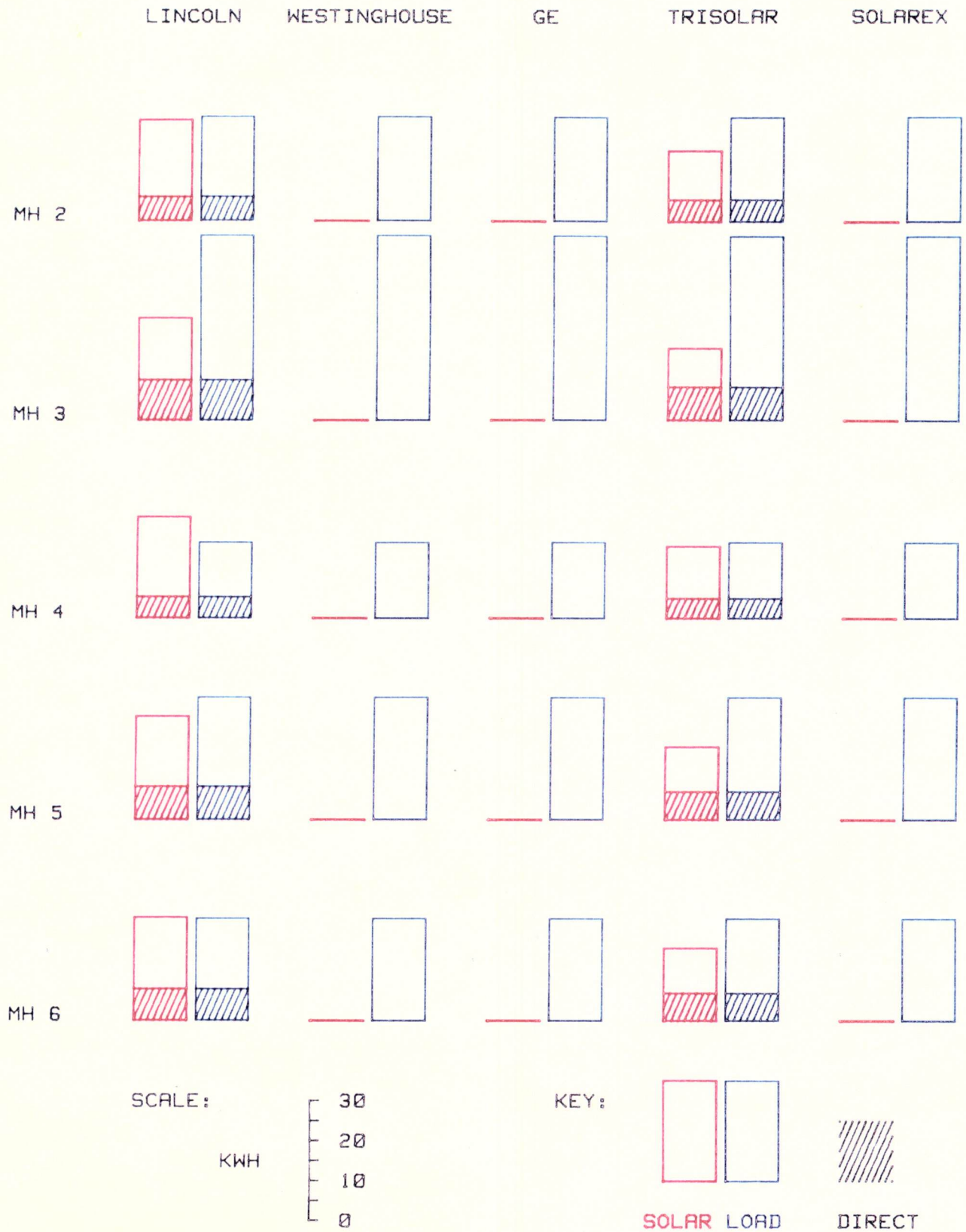

Table 3

MONTHLY SUMMARY REPORT March 1982

Site Location NEFES CARLE
Latitude: 42.46 42.53
Longitude: 71.30 71.36
Elevation: 40.5m 91.4m

METEOROLOGICAL INFORMATION		NEFES	CARLE	BOSTON NORMALS			
Average daily maximum ambient air temperature..... (deg. C)		7.37	8.26	7.00			
Average daily minimum ambient air temperature..... (deg. C)		-2.93	-3.26	-0.27			
Average ambient air temperature..... (deg. C)		2.46	2.36	3.38			
Total degree days heating/cooling..... (deg. C days)		492./ 0.	495./	0.	463./	0.	
Total precipitation..... (cm)		4.88	*****	10.16			
Average wind speed..... (m/s)		2.62	*****	6.21			
Average daily horizontal insolation..... (kWh/m**2/day)		3.42	*****	3.20			
MONITORED HOUSE INFORMATION		MH2	MH3	MH4	MH5	MH6	
Average daily electric energy used..... (kWh/day)		26.24	46.11	19.05	30.11	25.24	
Average daily electric energy used during sunhours..... (kWh/day)		11.67	24.82	9.10	18.11	14.79	
Monitored house data hours/hours in month..... (%)		99.77	77.46	99.60	98.51	60.70	
PHOTOVOLTAIC (PV) SYSTEM INFORMATION		MITLL	WEST	GE	TRISC	SOLRX	CARLE
PV ARRAY AND POWER CONDITIONING UNIT (PCU)							
Average daily array dc energy output..... (kWh/day)		27.84	*****	*****	19.95	*****	27.45
Average daily array dc energy output/rated array power (kWh/day/kWp)		4.09	*****	*****	4.17	*****	3.61
Peak array power for month..... (kW)		8.99	*****	*****	5.95	*****	7.86
Average daily array peak power..... (kW)		6.32	*****	*****	4.16	*****	5.60
Average daily total tilt insolation..... (kWh/m**2/day)		4.32	4.39	4.48	4.40	4.27	4.28
Average daily insolation during system on-hours..... (kWh/m**2/day)		4.38	*****	*****	4.41	*****	4.22
Insolation utilization efficiency..... (%)		95.76	*****	*****	99.46	*****	90.52
Peak insolation for month..... (kW/m**2)		1.20	1.26	1.29	1.27	1.27	1.15
Average daily peak insolation..... (kW/m**2)		0.88	0.90	0.90	0.91	0.88	0.80
Array efficiency..... (%)		7.88	*****	*****	9.61	*****	6.80
Average daily maximum array temperature..... (deg. C)		34.41	35.35	42.77	32.66	38.82	36.78
Average daily minimum array temperature..... (deg. C)		-6.63	-7.32	-6.36	-4.40	-4.64	-5.54
Average daily PCU ac energy output..... (kWh/day)		25.04	*****	*****	17.99	*****	25.20
Peak PCU power for month..... (kW)		8.28	*****	*****	5.63	*****	7.38
Average daily PCU peak power..... (kW)		5.83	*****	*****	3.90	*****	5.23
PCU efficiency..... (%)		89.94	*****	*****	90.18	*****	91.82
Array and PCU data hours during sunhours..... (hours/month)		283.29	*****	*****	352.50	*****	341.22
Sunhours..... (hours/month)		362.80	362.80	362.80	362.80	362.80	362.80
System reliability..... (%)		100.00	0.00	0.00	100.00	0.00	96.10
PV SYSTEM-UTILITY ENERGY FLOW		MITLL	WEST	GE	TRISC	SOLRX	CARLE
Average daily PCU ac energy output..... (kWh/day)		25.04	*****	*****	17.99	*****	25.20
Average daily energy from utility..... (kWh/day)		28.78	*****	*****	28.09	*****	80.61
Average daily energy to utility..... (kWh/day)		17.01	*****	*****	10.86	*****	14.49
Average daily energy to load..... (kWh/day)		36.39	*****	*****	35.20	*****	89.61
System-utility data hours/hours in month..... (%)		79.51	*****	*****	98.74	*****	95.62

NOTES: Imposed load changed from MH3 to MH5 on 3/19 thru 3/24. Light snowfall (1 inch or less) on 3/4, 3/9, 3/17, 3/19.

MITLL, WEST, TRISC, and Weather Station data system DACs offline 3/12 from 9:00 until mid-afternoon.

MITLL PV system off 3/10-3/17 for diagnostic equipment testing.

WEST inverter off since 2/20 pending repair.

GE inverter off since 2/12 pending repair.

SOLRX inverter off since 1/29 pending repair.

CARLE inverter off 3/14-3/15 due to DC fuse tripping; average of 6.08 kWh/day used for back-up resistance domestic hot water and space heating not included in load.

Table 4

NEEES MONTHLY SUMMARY

QUANTITY	UNITS	DEFINITION
METEOROLOGICAL INFORMATION		
Average daily maximum ambient air temperature.....	(deg. C)	Average of highest 6-minute-avg readings for each day
Average daily minimum ambient air temperature.....	(deg. C)	Average of lowest 6-minute-avg readings for each day
Average ambient air temperature.....	(deg. C)	Average of all readings for month
Total degree days heating/cooling.....	(deg. C days)	Heating base 18.3 deg. C, cooling base 23.9 deg. C
Total precipitation.....	(cm)	Expressed in equivalent centimeters of water
Average wind speed.....	(m/s)	Average of all readings for month
Average daily horizontal insolation.....	(kWh/m**2/day)	Sum of average-hour values for month
MONITORED HOUSE INFORMATION		
Average daily electric energy used.....	(kWh/day)	Sum of average-hour values for month
Average daily electric energy used during sunhours.....	(kWh/day)	Sum of average-hour values for month
Monitored House data hours/hours in month.....	(%)	Per cent monitored house data coverage for month
PHOTOVOLTAIC (PV) SYSTEM INFORMATION		
PV ARRAY AND POWER CONDITIONING UNIT (PCU)		
Average daily array dc energy output.....	(kWh/day)	Sum of average-hour values for month
Average daily array dc energy output/rated array power(kWh/day/kWp)		Sum of avg.-hour values for month/rated array peak power
Peak array power for month.....	(kW)	Highest of all 6-minute-peak readings for month
Average daily array peak power.....	(kW)	Avg. of highest 6-minute-peak readings for each day*
Average daily total tilt insolation.....	(kWh/m**2/day)	Sum of average-hour values for month
Average daily insolation during system on-hours.....	(kWh/m**2/day)	Sum of average-hour values for month
Insolation utilization efficiency.....	(%)	Total monthly insolation during system on-hours/ total monthly total tilt insolation
Peak insolation for month.....	(kW/m**2)	Highest of all 6-minute-peak readings for month
Average daily peak insolation.....	(kW/m**2)	Avg. of highest 6-minute-peak readings for each day*
Array efficiency.....	(%)	Average daily array dc energy output/(average daily insolation during system on-hours x array area)
Average daily maximum array temperature.....	(deg. C)	Avg. of highest 6-minute-avg readings for each day*
Average daily minimum array temperature.....	(deg. C)	Average of lowest 6-minute-avg readings for each day
Average daily PCU ac energy output.....	(kWh/day)	Sum of average-hour values for month
Peak PCU power for month.....	(kW)	Highest of all 6-minute-peak readings for month
Average daily PCU peak power.....	(kW)	Avg. of highest 6-minute-peak readings for each day*
PCU efficiency.....	(%)	Average daily PCU ac energy output/average daily array dc energy output
Array and PCU data hours during sunhours.....	(hours/month)	Hrs of data upon which energy outputs + effc's. are based
Sunhours.....	(hours/month)	Algorithmically computed daylight hours
System reliability.....	(%)	Total hours of PV system operational availability during sunhours/total sunhours in month
PV SYSTEM-UTILITY ENERGY FLOW		
Average daily PCU ac energy output.....	(kWh/day)	Sum of average-hour values for month
Average daily energy from utility.....	(kWh/day)	Sum of average-hour values for month
Average daily energy to utility.....	(kWh/day)	Sum of average-hour values for month
Average daily energy to load.....	(kWh/day)	Sum of average-hour values for month
System-utility data hours/hours in month.....	(%)	Hrs of data upon which sys-util calc's are based/hrs in mth

*Day is omitted from average if 1 consecutive hour of data is missing or invalid from 10 a.m. to 2 p.m.

TABLE 5

BRIEF MONTHLY REPORT

March 1982

Monitored House Data

TOTAL ELECTRIC ENERGY USED (KWH)																									
MONTHLY AVERAGE ENERGY FOR EACH HOUR ENDING AT LOCAL STANDARD TIME																									
HOUR	1	2	3	4	5	6	7	8	9	10	11	12	13	14	15	16	17	18	19	20	21	22	23	24	TOTAL
MH2	0.54	0.55	0.56	0.56	0.56	0.56	0.70	1.22	1.10	0.91	0.83	0.78	0.90	0.73	0.72	0.87	1.27	2.13	1.63	1.42	1.63	1.81	2.08	1.91	26.99
MH3	1.18	1.10	1.08	0.97	1.25	1.08	3.36	2.78	2.16	1.71	1.18	1.22	2.10	2.12	1.91	1.91	1.81	3.20	2.88	3.43	2.71	2.59	1.41	1.22	46.57
MH4	0.62	0.48	0.43	0.42	0.42	0.41	0.42	0.71	0.66	0.68	0.82	0.93	1.26	0.85	0.76	0.67	0.68	1.01	1.63	1.35	1.27	1.00	0.85	0.76	19.43
MH5	0.70	0.64	0.59	0.54	0.54	0.63	1.61	2.92	2.03	1.92	2.26	1.04	1.21	0.98	1.07	1.03	0.94	1.51	1.49	1.94	1.97	1.31	0.82	0.54	30.25
MH6	0.79	0.59	0.51	0.52	0.49	0.52	0.50	0.97	0.93	1.00	0.97	1.05	1.90	1.81	1.55	1.46	0.98	1.85	1.84	1.30	1.19	0.95	0.87	0.79	25.34
CARL	4.16	4.04	4.10	4.22	4.35	4.44	4.61	4.49	4.23	3.64	2.96	2.69	2.52	2.35	2.44	2.71	2.91	3.31	3.87	4.35	4.33	4.10	3.87	3.90	86.56

Prototype Systems Data

DC ARRAY OUTPUT (KWH)																									
MONTHLY AVERAGE ENERGY FOR EACH HOUR ENDING AT LOCAL STANDARD TIME																									
HOUR	1	2	3	4	5	6	7	8	9	10	11	12	13	14	15	16	17	18	19	20	21	22	23	24	TOTAL
MITI	0.00	0.00	0.00	0.00	0.00	0.00	0.19	1.02	2.25	3.30	4.04	4.23	4.08	3.48	2.83	2.00	0.86	0.15	0.00	0.0	0.0	0.0	0.0	0.0	26.43
WEST	0.0	0.0	0.0	0.0	0.0	0.0	0.0	0.0	0.0	0.0	0.0	0.0	0.0	0.0	0.0	0.0	0.0	0.0	0.0	0.0	0.0	0.0	0.0	0.0	0.0
GE	0.0	0.0	0.0	0.0	0.0	0.0	0.0	0.0	0.0	0.0	0.0	0.0	0.0	0.0	0.0	0.0	0.0	0.0	0.0	0.0	0.0	0.0	0.0	0.0	0.0
TRIS	0.00	0.00	0.00	0.00	0.00	0.01	0.16	0.74	1.51	2.27	2.76	2.86	2.82	2.56	2.21	1.50	0.56	0.09	0.00	0.00	0.00	0.00	0.00	0.00	20.06
SOLR	0.0	0.0	0.0	0.0	0.0	0.0	0.0	0.0	0.0	0.0	0.0	0.0	0.0	0.0	0.0	0.0	0.0	0.0	0.0	0.0	0.0	0.0	0.0	0.0	0.0
CARL	0.00	0.00	0.00	0.00	0.00	0.00	0.08	0.89	2.07	3.30	4.04	3.94	4.09	3.83	3.07	1.88	0.70	0.04	0.00	0.00	0.00	0.10	0.00	0.00	27.65

AC INVERTER - REAL ENERGY OUTPUT (KWH)																									
MONTHLY AVERAGE ENERGY FOR EACH HOUR ENDING AT LOCAL STANDARD TIME																									
HOUR	1	2	3	4	5	6	7	8	9	10	11	12	13	14	15	16	17	18	19	20	21	22	23	24	TOTAL
MITI	-0.03	-0.03	-0.03	-0.03	-0.03	-0.03	0.14	0.91	2.05	3.03	3.72	3.89	3.75	3.19	2.59	1.81	0.75	0.09	-0.03	-0.03	-0.03	-0.03	-0.03	-0.03	25.58
WEST	0.0	0.0	0.0	0.0	0.0	0.0	0.0	0.0	0.0	0.0	0.0	0.0	0.0	0.0	0.0	0.0	0.0	0.0	0.0	0.0	0.0	0.0	0.0	0.0	0.0
GE	0.0	0.0	0.0	0.0	0.0	0.0	0.0	0.0	0.0	0.0	0.0	0.0	0.0	0.0	0.0	0.0	0.0	0.0	0.0	0.0	0.0	0.0	0.0	0.0	0.0
TRIS	-0.04	-0.03	-0.03	-0.03	-0.03	-0.03	0.10	0.66	1.39	2.11	2.58	2.67	2.63	2.39	2.06	1.38	0.48	0.04	-0.03	-0.03	-0.03	-0.03	-0.03	-0.03	18.05
SOLR	0.0	0.0	0.0	0.0	0.0	0.0	0.0	0.0	0.0	0.0	0.0	0.0	0.0	0.0	0.0	0.0	0.0	0.0	0.0	0.0	0.0	0.0	0.0	0.0	0.0
CARL	-0.01	-0.01	-0.01	-0.01	-0.01	-0.01	0.05	0.80	1.91	3.07	3.77	3.67	3.81	3.56	2.83	1.71	0.61	0.01	-0.01	-0.01	-0.01	-0.01	-0.01	-0.01	25.67

MAXIMUM INVERTER AC POWER (KW)																									
MONTHLY AVERAGE MAX POWER FOR EACH HOUR ENDING AT LOCAL STANDARD TIME																									
HOUR	1	2	3	4	5	6	7	8	9	10	11	12	13	14	15	16	17	18	19	20	21	22	23	24	TOTAL
MITI	0.0	0.0	0.0	0.0	0.0	0.01	0.49	1.68	3.07	4.34	5.12	5.38	4.85	4.23	3.41	2.68	1.56	0.35	0.0	0.0	0.0	0.0	0.0	0.0	0.0
WEST	0.0	0.0	0.0	0.0	0.0	0.0	0.0	0.0	0.0	0.0	0.0	0.0	0.0	0.0	0.0	0.0	0.0	0.0	0.0	0.0	0.0	0.0	0.0	0.0	0.0
GE	0.0	0.0	0.0	0.0	0.0	0.0	0.0	0.0	0.0	0.0	0.0	0.0	0.0	0.0	0.0	0.0	0.0	0.0	0.0	0.0	0.0	0.0	0.0	0.0	0.0
TRIS	0.0	0.0	0.0	0.0	0.0	0.01	0.37	1.17	2.10	2.51	3.40	3.56	3.32	3.01	2.61	1.95	1.14	0.15	0.0	0.0	0.0	0.0	0.0	0.0	0.0
SOLR	0.0	0.0	0.0	0.0	0.0	0.0	0.0	0.0	0.0	0.0	0.0	0.0	0.0	0.0	0.0	0.0	0.0	0.0	0.0	0.0	0.0	0.0	0.0	0.0	0.0
CARL	0.0	0.00	0.00	0.00	0.00	0.00	0.27	1.46	2.59	3.86	4.68	4.48	4.44	4.30	3.57	2.28	1.08	0.06	0.00	0.00	0.00	0.00	0.00	0.00	0.00

LOAD IMPOSED ON THE PROTOTYPE (KWH)
MONTHLY AVERAGE ENERGY FOR EACH HOUR ENDING AT LOCAL STANDARD TIME

HOURL	1	2	3	4	5	6	7	8	9	10	11	12	13	14	15	16	17	18	19	20	21	22	23	24	TOTAL
MITI	1.03	0.87	0.55	0.81	1.02	0.91	2.68	2.67	1.75	1.49	1.21	1.01	1.64	1.63	1.62	1.62	1.56	1.92	1.98	2.30	2.02	1.91	1.08	1.03	36.74
WEST	0.0	0.0	0.0	0.0	0.0	0.0	0.0	0.0	0.0	0.0	0.0	0.0	0.0	0.0	0.0	0.0	0.0	0.0	0.0	0.0	0.0	0.0	0.0	0.0	0.0
GE	0.0	0.0	0.0	0.0	0.0	0.0	0.0	0.0	0.0	0.0	0.0	0.0	0.0	0.0	0.0	0.0	0.0	0.0	0.0	0.0	0.0	0.0	0.0	0.0	0.0
TRIS	1.05	0.97	0.95	0.85	1.01	0.97	2.10	2.56	1.65	1.25	1.37	1.18	1.63	1.57	1.56	1.57	1.45	1.88	1.93	1.87	1.89	1.93	1.20	1.06	35.43
SOLE	0.0	0.0	0.0	0.0	0.0	0.0	0.0	0.0	0.0	0.0	0.0	0.0	0.0	0.0	0.0	0.0	0.0	0.0	0.0	0.0	0.0	0.0	0.0	0.0	0.0
CABL	4.22	4.09	4.14	4.26	4.39	4.47	4.64	4.53	4.27	3.72	3.04	2.75	2.66	2.47	2.46	2.77	2.94	3.41	3.99	4.41	4.33	4.19	3.93	3.96	90.05

ENERGY SUPPLIED TO UTILITY (KWH)
MONTHLY AVERAGE ENERGY FOR EACH HOUR ENDING AT LOCAL STANDARD TIME

HOURL	1	2	3	4	5	6	7	8	9	10	11	12	13	14	15	16	17	18	19	20	21	22	23	24	TOTAL	
MITI	0.0	0.0	0.0	0.0	0.0	0.0	0.01	0.17	1.14	1.58	2.77	3.19	2.82	2.15	1.78	1.05	0.33	0.01	0.0	0.0	0.0	0.0	0.0	0.0	0.0	17.39
WEST	0.0	0.0	0.0	0.0	0.0	0.0	0.0	0.0	0.0	0.0	0.0	0.0	0.0	0.0	0.0	0.0	0.0	0.0	0.0	0.0	0.0	0.0	0.0	0.0	0.0	0.0
GE	0.0	0.0	0.0	0.0	0.0	0.0	0.0	0.0	0.0	0.0	0.0	0.0	0.0	0.0	0.0	0.0	0.0	0.0	0.0	0.0	0.0	0.0	0.0	0.0	0.0	0.0
TRIS	0.0	0.0	0.0	0.0	0.0	0.0	0.01	0.10	0.69	1.24	1.58	1.92	1.69	1.52	1.29	0.70	0.17	0.00	0.0	0.0	0.0	0.0	0.0	0.0	0.0	10.91
SOLE	0.0	0.0	0.0	0.0	0.0	0.0	0.0	0.0	0.0	0.0	0.0	0.0	0.0	0.0	0.0	0.0	0.0	0.0	0.0	0.0	0.0	0.0	0.0	0.0	0.0	0.0
CABL	0.0	0.0	0.0	0.0	0.0	0.0	0.00	0.09	0.45	1.26	2.28	2.40	2.71	2.62	1.89	0.97	0.21	0.00	0.0	0.0	0.0	0.0	0.0	0.0	0.0	14.69

ENERGY SUPPLIED BY UTILITY (KWH)
MONTHLY AVERAGE ENERGY FOR EACH HOUR ENDING AT LOCAL STANDARD TIME

HOURL	1	2	3	4	5	6	7	8	9	10	11	12	13	14	15	16	17	18	19	20	21	22	23	24	TOTAL	
MITI	1.08	0.91	0.99	0.85	1.06	0.96	2.57	1.95	0.89	0.45	0.28	0.33	0.72	0.61	0.83	0.88	1.16	1.86	2.03	2.35	2.06	1.95	1.13	1.07	28.97	
WEST	0.0	0.0	0.0	0.0	0.0	0.0	0.0	0.0	0.0	0.0	0.0	0.0	0.0	0.0	0.0	0.0	0.0	0.0	0.0	0.0	0.0	0.0	0.0	0.0	0.0	0.0
GE	0.0	0.0	0.0	0.0	0.0	0.0	0.0	0.0	0.0	0.0	0.0	0.0	0.0	0.0	0.0	0.0	0.0	0.0	0.0	0.0	0.0	0.0	0.0	0.0	0.0	0.0
TRIS	1.09	1.00	0.99	0.89	1.05	1.00	2.00	2.00	0.94	0.38	0.38	0.44	0.69	0.71	0.79	0.89	1.13	1.84	1.96	1.90	1.92	1.96	1.23	1.09	28.27	
SOLE	0.0	0.0	0.0	0.0	0.0	0.0	0.0	0.0	0.0	0.0	0.0	0.0	0.0	0.0	0.0	0.0	0.0	0.0	0.0	0.0	0.0	0.0	0.0	0.0	0.0	
CABL	4.32	4.18	4.23	4.35	4.48	4.56	4.66	3.88	2.87	1.98	1.62	1.55	1.63	1.60	1.58	2.10	2.61	3.46	4.08	4.50	4.41	4.27	4.02	4.05	80.99	

SCLAE ARRAY PANEL TEMPERATURE (DEG. C)
MONTHLY AVERAGE TEMPERATURE FOR EACH HOUR ENDING AT LOCAL STANDARD TIME

HOURL	1	2	3	4	5	6	7	8	9	10	11	12	13	14	15	16	17	18	19	20	21	22	23	24	TOTAL
MITI	-2.4	-3.1	-3.6	-4.1	-4.5	-4.8	-3.6	2.6	11.3	18.9	25.3	28.6	28.3	26.6	24.3	18.3	11.8	5.5	2.2	1.0	0.4	-0.2	-0.6	-1.1	
WEST	-2.7	-3.5	-4.0	-4.5	-4.9	-5.1	-3.6	3.5	12.6	20.5	26.4	29.0	28.4	26.6	24.1	18.0	11.3	4.8	1.8	0.6	0.0	-0.6	-1.0	-1.4	
GE	-1.5	-2.3	-2.8	-3.4	-3.8	-4.0	-2.7	4.5	15.3	25.0	32.1	36.1	35.7	33.3	29.9	23.0	15.0	7.4	3.5	2.1	1.4	0.8	0.4	-0.1	
TRIS	0.0	-0.7	-1.3	-1.8	-2.2	-2.5	-1.3	4.4	12.5	20.1	25.3	27.3	27.1	25.6	24.0	19.5	13.9	8.2	5.2	3.8	3.0	2.3	1.8	1.4	
SOLE	-0.4	-1.1	-1.6	-2.1	-2.4	-2.7	-1.4	5.2	14.8	23.4	29.4	32.1	31.4	25.4	26.5	20.6	13.8	7.5	4.1	2.9	2.3	1.8	1.4	0.9	
CABL	-1.7	-2.3	-2.8	-3.1	-3.4	-3.6	-2.7	3.3	12.5	21.0	26.7	29.8	30.7	30.0	26.4	19.7	12.6	6.1	2.9	1.6	0.8	0.3	-0.0	-0.4	

TOTAL TILT INSOLATION (KWH/M**2)
MONTHLY AVERAGE ENERGY /M**2 FOR EACH HOUR ENDING AT LOCAL STANDARD TIME

HOURL	1	2	3	4	5	6	7	8	9	10	11	12	13	14	15	16	17	18	19	20	21	22	23	24	TOTAL	
MITI	0.0	0.0	0.0	0.0	0.0	0.00	0.04	0.17	0.33	0.48	0.59	0.63	0.61	0.55	0.45	0.31	0.15	0.03	0.00	0.0	0.0	0.0	0.0	0.0	0.0	4.34
WEST	0.0	0.0	0.0	0.0	0.0	0.00	0.03	0.17	0.33	0.49	0.60	0.64	0.62	0.56	0.47	0.31	0.16	0.03	0.00	0.0	0.0	0.00	0.0	0.00	0.00	4.41
GE	0.00	0.00	0.00	0.00	0.00	0.00	0.05	0.18	0.35	0.51	0.60	0.64	0.62	0.56	0.47	0.32	0.16	0.04	0.00	0.00	0.00	0.00	0.00	0.00	0.00	4.50
TRIS	0.0	0.0	0.0	0.0	0.0	0.00	0.04	0.19	0.35	0.50	0.61	0.64	0.62	0.55	0.45	0.30	0.14	0.02	0.00	0.0	0.0	0.0	0.0	0.0	0.0	4.42
SOLE	0.0	0.0	0.0	0.0	0.0	0.00	0.03	0.15	0.32	0.47	0.57	0.62	0.60	0.55	0.46	0.32	0.16	0.03	0.00	0.0	0.0	0.0	0.0	0.00	0.00	4.29
CABL	0.00	0.00	0.00	0.00	0.00	0.00	0.04	0.17	0.33	0.49	0.59	0.60	0.62	0.56	0.48	0.30	0.12	0.02	0.00	0.00	0.00	0.00	0.00	0.00	0.00	4.34

Hypothetical Prototype—Monitored House Energy Exchange

MITLL - HYPOTHETICAL ENERGY TO UTILITY IF MITLL WERE INSTALLED AT EACH MH (KWH)
MONTHLY AVERAGE ENERGY FOR EACH HOUR ENDING AT LOCAL STANDARD TIME

HOUR	1	2	3	4	5	6	7	8	9	10	11	12	13	14	15	16	17	18	19	20	21	22	23	24	TOTAL	
MH2	0.0	0.0	0.0	0.0	0.0	0.0	0.01	0.32	1.37	2.30	3.07	3.28	3.01	2.58	2.06	1.25	0.27	0.00	0.0	0.0	0.0	0.0	0.0	0.0	0.0	19.53
MH3	C.C	0.0	C.0	C.0	0.0	0.0	0.00	0.12	0.97	1.87	2.73	2.93	2.50	1.78	1.43	0.89	0.23	0.00	0.0	0.0	0.0	0.0	0.0	0.0	0.0	15.45
MH4	C.C	0.0	0.0	C.0	0.0	0.0	0.04	0.43	1.50	2.42	2.99	3.15	3.12	2.65	2.10	1.38	0.41	0.02	0.0	0.0	0.0	0.0	0.0	0.0	0.0	20.21
MH5	0.0	0.0	0.0	C.0	0.0	0.0	0.01	0.13	0.92	1.86	2.22	3.16	2.94	2.59	1.91	1.22	0.35	0.02	0.0	0.0	0.0	0.0	0.0	0.0	0.0	17.33
MH6	0.0	0.0	0.0	C.0	0.0	0.0	0.04	0.37	1.35	2.09	2.99	3.11	2.79	2.30	1.26	1.05	0.41	0.00	0.0	0.0	0.0	0.0	0.0	0.0	0.0	17.75

WEST - HYPOTHETICAL ENERGY TO UTILITY IF WEST WERE INSTALLED AT EACH MH (KWH)
MONTHLY AVERAGE ENERGY FOR EACH HOUR ENDING AT LOCAL STANDARD TIME

HCUE	1	2	3	4	5	6	7	8	9	10	11	12	13	14	15	16	17	18	19	20	21	22	23	24	TOTAL	
MH2	C.C	C.0	C.0	C.0	0.0	0.0	0.0	0.0	0.0	0.0	0.0	0.0	0.0	C.0	C.0	0.0	0.0	0.0	0.0	0.0	0.0	0.0	0.0	0.0	0.0	0.0
MH3	0.0	0.0	C.0	C.0	0.0	0.0	0.0	0.0	0.0	0.0	0.0	0.0	0.0	0.0	0.0	0.0	0.0	0.0	0.0	0.0	0.0	0.0	0.0	0.0	0.0	0.0
MH4	0.0	0.0	C.0	C.0	0.0	0.0	0.0	0.0	0.0	0.0	0.0	0.0	0.0	0.0	0.0	0.0	0.0	0.0	0.0	0.0	0.0	0.0	0.0	0.0	0.0	0.0
MH5	C.C	0.0	C.0	0.0	0.0	0.0	0.0	0.0	0.0	0.0	0.0	0.0	0.0	C.0	0.0	0.0	0.0	0.0	0.0	0.0	0.0	0.0	0.0	0.0	0.0	0.0
MH6	C.C	C.C	C.0	C.0	0.0	0.0	0.0	0.0	0.0	0.0	0.0	0.0	0.0	C.0	C.0	0.0	0.0	0.0	0.0	0.0	0.0	0.0	0.0	0.0	0.0	0.0

GE - HYPOTHETICAL ENERGY TO UTILITY IF GE WERE INSTALLED AT EACH MH (KWH)
MONTHLY AVERAGE ENERGY FOR EACH HCUE ENDING AT LOCAL STANDARD TIME

HCUE	1	2	3	4	5	6	7	8	9	10	11	12	13	14	15	16	17	18	19	20	21	22	23	24	TOTAL	
MH2	0.0	0.0	0.0	0.0	0.0	0.0	0.0	0.0	0.0	0.0	0.0	0.0	0.0	0.0	0.0	0.0	0.0	0.0	0.0	0.0	0.0	0.0	0.0	0.0	0.0	0.0
MH3	C.C	0.0	C.0	C.0	0.0	0.0	0.0	0.0	0.0	0.0	0.0	0.0	0.0	0.0	0.0	0.0	0.0	0.0	0.0	0.0	0.0	0.0	0.0	0.0	0.0	0.0
MH4	C.C	0.0	0.0	0.0	0.0	0.0	0.0	0.0	0.0	0.0	0.0	0.0	0.0	C.0	C.0	0.0	0.0	0.0	0.0	0.0	0.0	0.0	0.0	0.0	0.0	0.0
MH5	0.0	0.0	0.0	0.0	0.0	0.0	0.0	0.0	0.0	0.0	0.0	0.0	0.0	0.0	0.0	0.0	0.0	0.0	0.0	0.0	0.0	0.0	0.0	0.0	0.0	0.0
MH6	0.0	0.0	C.0	C.C	0.0	0.0	0.0	0.0	0.0	0.0	0.0	0.0	0.0	0.0	0.0	0.0	0.0	0.0	0.0	0.0	0.0	0.0	0.0	0.0	0.0	0.0

TRISC - HYPOTHETICAL ENERGY TO UTILITY IF TRISC WERE INSTALLED AT EACH MH (KWH)
MONTHLY AVERAGE ENERGY FOR EACH HOUR ENDING AT LOCAL STANDARD TIME

HOUR	1	2	3	4	5	6	7	8	9	10	11	12	13	14	15	16	17	18	19	20	21	22	23	24	TOTAL	
MH2	C.C	0.0	0.0	C.0	0.0	0.0	0.00	0.14	0.75	1.48	1.95	2.09	1.96	1.80	1.48	0.78	0.11	0.00	0.0	0.0	0.0	0.0	0.0	0.0	0.0	12.55
MH3	0.0	0.0	0.0	0.0	0.0	0.0	0.00	0.07	0.50	1.17	1.68	1.77	1.56	1.27	1.07	0.56	0.09	0.00	0.0	0.0	0.0	0.0	0.0	0.0	0.0	9.74
MH4	0.0	0.0	0.0	0.0	0.0	0.0	0.02	0.23	0.85	1.55	1.94	1.96	1.97	1.85	1.58	0.95	0.18	0.00	0.0	0.0	0.0	0.0	0.0	0.0	0.0	13.08
MH5	C.0	0.0	C.0	0.0	0.0	0.0	0.00	0.06	0.52	1.16	1.30	1.99	1.88	1.71	1.41	0.84	0.17	0.00	0.0	0.0	0.0	0.0	0.0	0.0	0.0	11.05
MH6	0.0	0.0	0.0	0.0	0.0	0.0	0.02	0.16	0.71	1.33	1.81	2.02	1.63	1.53	1.15	0.78	0.16	0.0	0.0	0.0	0.0	0.0	0.0	0.0	0.0	11.28

SOLEX - HYPOTHETICAL ENERGY TO UTILITY IF SOLEX WERE INSTALLED AT EACH MH (KWH)
MONTHLY AVERAGE ENERGY FOR EACH HOUR ENDING AT LOCAL STANDARD TIME

HCUE	1	2	3	4	5	6	7	8	9	10	11	12	13	14	15	16	17	18	19	20	21	22	23	24	TOTAL	
MH2	C.C	0.0	0.0	C.0	0.0	0.0	0.0	0.0	0.0	0.0	0.0	0.0	0.0	C.0	C.0	0.0	0.0	0.0	0.0	0.0	0.0	0.0	0.0	0.0	0.0	0.0
MH3	0.0	0.0	0.0	0.0	0.0	0.0	0.0	0.0	0.0	0.0	0.0	0.0	0.0	0.0	0.0	0.0	0.0	0.0	0.0	0.0	0.0	0.0	0.0	0.0	0.0	0.0
MH4	0.0	0.0	0.0	C.C	0.0	0.0	0.0	0.0	0.0	0.0	0.0	0.0	0.0	0.0	0.0	0.0	0.0	0.0	0.0	0.0	0.0	0.0	0.0	0.0	0.0	0.0
MH5	C.C	0.0	C.0	C.0	0.0	0.0	0.0	0.0	0.0	0.0	0.0	0.0	0.0	C.0	C.0	0.0	0.0	0.0	0.0	0.0	0.0	0.0	0.0	0.0	0.0	0.0
MH6	C.C	C.0	C.0	0.0	0.0	0.0	0.0	0.0	0.0	0.0	0.0	0.0	0.0	C.0	C.0	0.0	0.0	0.0	0.0	0.0	0.0	0.0	0.0	0.0	0.0	0.0

MILL -HYPOTHETICAL ENERGY FROM UTILITY IF MILL WERE INSTALLED AT EACH MH (KWH)
MONTHLY AVERAGE ENERGY FOR EACH HOUR ENDING AT LOCAL STANDARD TIME

HOUR	1	2	3	4	5	6	7	8	9	10	11	12	13	14	15	16	17	18	19	20	21	22	23	24	TOTAL
MH2	0.92	0.58	0.60	0.61	0.59	0.59	0.58	0.66	0.33	0.22	0.25	0.23	0.24	0.18	0.17	0.29	0.77	2.17	1.72	1.51	1.77	1.95	2.09	1.67	20.67
MH3	1.33	1.09	1.22	1.08	1.39	1.17	3.50	2.08	1.11	0.49	0.14	0.24	0.95	0.68	0.95	1.03	1.46	2.84	2.98	3.04	2.91	2.71	1.46	1.36	37.26
MH4	0.65	0.53	0.47	0.45	0.45	0.45	0.33	0.26	0.14	0.09	0.05	0.15	0.32	0.21	0.28	0.22	0.34	0.93	1.73	1.39	1.35	1.06	0.89	0.77	13.53
MH5	0.74	0.68	0.60	0.54	0.61	0.72	1.35	1.89	1.15	0.86	0.67	0.21	0.43	0.35	0.32	0.50	0.62	1.63	1.48	2.10	2.05	1.37	0.91	0.61	22.40
MH6	0.80	0.57	0.54	0.52	0.52	0.54	0.38	0.45	0.28	0.11	0.05	0.04	0.47	0.55	0.44	0.65	0.50	1.33	1.75	1.26	1.06	0.98	0.85	0.76	15.40

WEST -HYPOTHETICAL ENERGY FROM UTILITY IF WEST WERE INSTALLED AT EACH MH (KWH)
MONTHLY AVERAGE ENERGY FOR EACH HOUR ENDING AT LOCAL STANDARD TIME

HCUB	1	2	3	4	5	6	7	8	9	10	11	12	13	14	15	16	17	18	19	20	21	22	23	24	TOTAL	
MH2	C.C	0.0	0.0	C.0	0.0	0.0	0.0	0.0	0.0	0.0	0.0	0.0	0.0	C.0	C.0	0.0	0.0	0.0	0.0	0.0	0.0	0.0	0.0	0.0	0.0	0.0
MH3	0.0	0.0	0.0	C.0	0.0	0.0	0.0	0.0	0.0	0.0	0.0	0.0	0.0	0.0	0.0	0.0	0.0	0.0	0.0	0.0	0.0	0.0	0.0	0.0	0.0	0.0
MH4	0.0	0.0	0.0	C.0	0.0	0.0	0.0	0.0	0.0	0.0	0.0	0.0	0.0	0.0	0.0	0.0	0.0	0.0	0.0	0.0	0.0	0.0	0.0	0.0	0.0	0.0
MH5	C.C	0.0	0.0	C.0	0.0	0.0	0.0	0.0	0.0	0.0	0.0	0.0	0.0	C.0	0.0	0.0	0.0	0.0	0.0	0.0	0.0	0.0	0.0	0.0	0.0	0.0
MH6	C.C	C.0	C.C	C.0	0.0	0.0	0.0	0.0	0.0	0.0	0.0	0.0	0.0	0.0	0.0	0.0	0.0	0.0	0.0	0.0	0.0	0.0	0.0	0.0	0.0	0.0

GE -HYPOTHETICAL ENERGY FROM UTILITY IF GE WERE INSTALLED AT EACH MH (KWH)
MONTHLY AVERAGE ENERGY FOR EACH HOUR ENDING AT LOCAL STANDARD TIME

HCUB	1	2	3	4	5	6	7	8	9	10	11	12	13	14	15	16	17	18	19	20	21	22	23	24	TOTAL	
MH2	0.0	0.0	0.0	0.0	0.0	0.0	0.0	0.0	0.0	0.0	0.0	0.0	0.0	0.0	0.0	0.0	0.0	0.0	0.0	0.0	0.0	0.0	0.0	0.0	0.0	0.0
MH3	C.C	0.0	0.0	C.0	0.0	0.0	0.0	0.0	0.0	0.0	0.0	0.0	0.0	C.0	0.0	0.0	0.0	0.0	0.0	0.0	0.0	0.0	0.0	0.0	0.0	0.0
MH4	C.C	0.0	C.0	C.0	0.0	0.0	0.0	0.0	0.0	0.0	0.0	0.0	0.0	C.0	0.0	0.0	0.0	0.0	0.0	0.0	0.0	0.0	0.0	0.0	0.0	0.0
MH5	0.0	0.0	0.0	C.0	0.0	0.0	0.0	0.0	0.0	0.0	0.0	0.0	0.0	0.0	0.0	0.0	0.0	0.0	0.0	0.0	0.0	0.0	0.0	0.0	0.0	0.0
MH6	0.0	0.0	0.0	0.0	0.0	0.0	0.0	0.0	0.0	0.0	0.0	0.0	0.0	0.0	0.0	0.0	0.0	0.0	0.0	0.0	0.0	0.0	0.0	0.0	0.0	0.0

TRISC -HYPOTHETICAL ENERGY FROM UTILITY IF TRISC WERE INSTALLED AT EACH MH (KWH)
MONTHLY AVERAGE ENERGY FOR EACH HOUR ENDING AT LOCAL STANDARD TIME

HOUR	1	2	3	4	5	6	7	8	9	10	11	12	13	14	15	16	17	18	19	20	21	22	23	24	TOTAL
MH2	0.58	0.59	0.55	0.59	0.59	0.59	0.60	0.71	0.46	0.26	0.22	0.21	0.24	0.15	0.14	0.28	0.89	2.08	1.66	1.46	1.67	1.84	2.12	1.95	10.87
MH3	1.21	1.14	1.11	1.00	1.28	1.12	3.27	2.26	1.36	0.75	0.34	0.41	0.99	1.02	0.97	1.09	1.42	3.15	2.92	3.46	2.75	2.62	1.45	1.26	28.34
MH4	0.66	0.51	0.46	0.45	0.46	0.44	0.34	0.29	0.15	0.10	0.20	0.23	0.60	0.30	0.30	0.24	0.37	0.97	1.67	1.38	1.31	1.03	0.88	0.79	14.15
MH5	0.74	0.68	0.63	0.57	0.57	0.66	1.50	2.35	1.16	0.96	1.02	0.37	0.47	0.34	0.37	0.49	0.63	1.47	1.53	1.97	1.99	1.34	0.80	0.58	23.26
MH6	0.63	0.63	0.55	0.55	0.53	0.55	0.41	0.53	0.31	0.20	0.20	0.23	0.62	0.76	0.59	0.75	0.63	1.79	1.87	1.34	1.22	0.98	0.91	0.82	17.62

SOLEX -HYPOTHETICAL ENERGY FROM UTILITY IF SOLEX WERE INSTALLED AT EACH MH (KWH)
MONTHLY AVERAGE ENERGY FOR EACH HOUR ENDING AT LOCAL STANDARD TIME

HOUR	1	2	3	4	5	6	7	8	9	10	11	12	13	14	15	16	17	18	19	20	21	22	23	24	TOTAL	
MH2	0.0	0.0	0.0	0.0	0.0	0.0	0.0	0.0	0.0	0.0	0.0	0.0	0.0	0.0	0.0	0.0	0.0	0.0	0.0	0.0	0.0	0.0	0.0	0.0	0.0	0.0
MH3	0.0	0.0	0.0	0.0	0.0	0.0	0.0	0.0	0.0	0.0	0.0	0.0	0.0	0.0	0.0	0.0	0.0	0.0	0.0	0.0	0.0	0.0	0.0	0.0	0.0	0.0
MH4	C.C	C.0	0.0	C.0	0.0	0.0	0.0	0.0	0.0	0.0	0.0	0.0	0.0	C.0	C.0	0.0	0.0	0.0	0.0	0.0	0.0	0.0	0.0	0.0	0.0	0.0
MH5	0.0	0.0	0.0	0.0	0.0	0.0	0.0	0.0	0.0	0.0	0.0	0.0	0.0	0.0	0.0	0.0	0.0	0.0	0.0	0.0	0.0	0.0	0.0	0.0	0.0	0.0
MH6	0.0	0.0	C.0	0.0	0.0	0.0	0.0	0.0	0.0	0.0	0.0	0.0	0.0	0.0	0.0	0.0	0.0	0.0	0.0	0.0	0.0	0.0	0.0	0.0	0.0	0.0

Monitored House Load Duration Data

